

User Manual

Tektronix

**TDC5
Tunable Down Converter
070-8993-00**

This document applies for firmware
version 1.04.

**Please check for change information
at the rear of this manual.**

First Printing May 1994
Revised July 1994

Copyright © Tektronix, Inc., 1994. All rights reserved. Printed in U.S.A. Tektronix products are covered by U.S. and foreign patents, issued and pending.

Information in this publication supersedes that in all previously published material. Specifications and price change privileges reserved. The following are registered trademarks: TEKTRONIX and TEK.

For further information, contact: Tektronix, Inc., Corporate Offices, P.O. Box 1000, Wilsonville, OR 97070-1000, U.S.A. Phone: (503) 627-7111; TLX: 192825; TWX: (910) 467-8708; Cable: TEKWSGT.

Tektronix' Television Division participates in the Broadcast Professionals Forum (BPFORUM) on the CompuServe® Information Service. Press releases on new products, product-specific newsletters, application information, technical papers, and software libraries for programmable products are among the types of information uploaded.

Additionally, product specialists from Tektronix will be "on line" to answer questions regarding product applications, operation and maintenance.

Instructions for accessing the information on CompuServe can be found in the current Tektronix Television Products Catalog.

CompuServe access is currently available in the U.S.A., Canada, Europe, Japan, Australia, and New Zealand.

WARRANTY

Tektronix warrants that this product will be free from defects in materials and workmanship for a period of 1 year from the date of shipment. If any such product proves defective during this warranty period, Tektronix, at its option, either will repair the defective product without charge for parts and labor, or will provide a replacement in exchange for the defective product.

In order to obtain service under this warranty, Customer must notify Tektronix of the defect before the expiration of the warranty period and make suitable arrangements for the performance of service. Customer shall be responsible for packaging and shipping the defective product to the service center designated by Tektronix, with shipping charges prepaid. Tektronix shall pay for the return of the product to Customer if the shipment is to a location within the country in which the Tektronix service center is located. Customer shall be responsible for paying all shipping charges, duties, taxes, and any other charges for products returned to any other locations.

This warranty shall not apply to any defect, failure or damage caused by improper use or improper or inadequate maintenance and care. Tektronix shall not be obligated to furnish service under this warranty a) to repair damage resulting from attempts by personnel other than Tektronix representatives to install, repair or service the product; b) to repair damage resulting from improper use or connection to incompatible equipment; c) to repair any damage or malfunction caused by the use of non-Tektronix supplies; or d) to service a product that has been modified or integrated with other products when the effect of such modification or integration increases the time or difficulty of servicing the product

THIS WARRANTY IS GIVEN BY TEKTRONIX WITH RESPECT TO THIS PRODUCT IN LIEU OF ANY OTHER WARRANTIES, EXPRESSED OR IMPLIED. TEKTRONIX AND ITS VENDORS DISCLAIM ANY IMPLIED WARRANTIES OF MERCHANTABILITY OR FITNESS FOR A PARTICULAR PURPOSE. TEKTRONIX' RESPONSIBILITY TO REPAIR OR REPLACE DEFECTIVE PRODUCTS IS THE SOLE AND EXCLUSIVE REMEDY PROVIDED TO THE CUSTOMER FOR BREACH OF THIS WARRANTY. TEKTRONIX AND ITS VENDORS WILL NOT BE LIABLE FOR ANY INDIRECT, SPECIAL, INCIDENTAL, OR CONSEQUENTIAL DAMAGES IRRESPECTIVE OF WHETHER TEKTRONIX OR THE VENDOR HAS ADVANCE NOTICE OF THE POSSIBILITY OF SUCH DAMAGES.





Table of Contents

Getting Started

Introduction	1-1
System Applications	1-1
Standard Accessories	1-2
Installation	1-3
Electrical Installation	1-3
Changing the Mains Voltage	1-4
Rackmount Information	1-5
Rack Installation Procedure	1-6
Operator's Checkout Procedure	1-9

Operating Basics

Functional Overview	2-1
Controls and Connectors	2-1
Operating Procedures	2-5
Instrument Power On	2-5
Enter the Menu	2-5
Select Tuning Method (TUNING)	2-7
Tune (FREQ or CH)	2-8
Input (INP)	2-10
Automatic Gain Control (AGC)	2-10
Delay (DELAY)	2-11
Attenuation (RF, IF, TOTAL)	2-11
Storing Presets (PROGRAM PRESETS and SAVE AS...)	2-12
Recalling Presets (Tuning by Preset)	2-14
Set Up Remote Interface (PROGRAM COMM-PORT) ...	2-16

Reference

Menu Overview	3-1
Quick Guide	3-1
Menu Reference	3-3
Frequency (FREQ)	3-3
Channel (CH)	3-4
Presets (PR)	3-5
Input	3-5
AGC	3-5
Delay	3-6
Total Attenuation	3-6
IF Attenuation	3-7
RF Attenuation	3-7
Save As...	3-7
Tuning	3-8
Program Presets	3-8
Program Comm-Port	3-8
Messages	3-9
Type	3-9
Baud Rate	3-9
Address	3-10
Send Test Message	3-10

Appendices

Appendix A: Performance Specification	A-1
Electrical Specification	A-1
Environmental Characteristics	A-3
Physical Characteristics	A-4
Appendix B: Remote Control	B-1
RS232 Communication	B-1
RS485 Communication	B-2
Appendix C: Service	C-1
Packaging for Shipment	C-1
Adjusting the Display	C-2
Appendix D: Channel Tables	D-1
Appendix E: Remote Commands	E-1
List of Commands	E-1

Explanation of Remote Command Descriptions	E-3
Terms Used in Remote Command Descriptions	E-6
Remote Command Descriptions	E-6
PWD	E-6
DISC	E-6
MSG	E-7
IDN	E-9
LOG	E-10
PATH	E-11
INP	E-12
FREQ	E-13
AGC_C	E-14
RF_ATT	E-15
IF_ATT	E-16
DELAY	E-17
CHANNEL	E-18
SETT	E-19
TUNING	E-21
RECPRT	E-22
PRESET	E-23
MSG_C	E-25
STAT	E-26
REPORT	E-28
OPTMEM	E-29
Appendix F: Remote Communication	F-1
Protocol	F-1
Using Terminal Programs	F-2
Addresses	F-2
Sending Data to the TDC5	F-3
Receiving Data from the TDC5	F-4
Polling the TDC5	F-5

Index

Index Entries	Index-1
---------------------	---------

List of Figures

Figure 1–1: Rear-panel Input Connector	1–4
Figure 1–2: Installing Rackmount Hardware	1–7
Figure 2–1: TDC5 Front and Rear Panels	2–3
Figure 2–2: The TDC5 Display After Selecting MENU	2–6
Figure 2–3: The TDC5 Display After Advancing to TUNING ..	2–7
Figure 2–4: The TDC5 Display After Selecting TUNING	2–7
Figure 2–5: Tuning by Frequency	2–10
Figure 2–6: Setting Attenuation (AGC OFF)	2–12
Figure 2–7: Preset Default Settings	2–13
Figure 2–8: Programming a Preset (AGC OFF)	2–14
Figure 2–9: Recalling a Preset	2–15
Figure 2–10: Programming the Communications Interface ...	2–16
Figure 3–1: TDC5 Menu Hierarchy	3–2
Figure B–1: Rear-panel RS232 Connector	B–2
Figure B–2: Rear-panel RS485 Connector	B–2
Figure C–1: Circuit Board Layout, Showing Location of P1 ..	C–2

List of Tables

Table B–1: RS232 Pin Connections	B–1
Table B–2: RS485 Pin Connections	B–2
Table D–1: CATV Standard Channel Table	D–1
Table D–2: HRC Channel Table	D–3
Table D–3: Broadcast Channel Table	D–4
Table F–1: Special Bytes	F–1
Table F–2: Windows Terminal Program	F–2

User Safety Summary

Please take a moment to review these safety precautions. They are provided for your protection and to prevent damage to the product. This safety information applies to all operators.

Terms Appearing in Manuals



CAUTION. *Caution statements identify conditions or practices that could result in damage to the equipment or other property.*



WARNING. *Warning statements identify conditions or practices that could result in personal injury or loss of life.*

Terms Appearing on Equipment

CAUTION indicates a personal injury hazard not immediately accessible as one reads the marking or a hazard to property including the equipment itself.

DANGER indicates a personal injury hazard immediately accessible as one reads the marking.

Symbols Appearing on Equipment



DANGER
High Voltage



Protective ground
(earth) terminal



ATTENTION
Refer to
manual

Precautions

Power Source

This product is designed to operate from a power source that will not apply more than 250 V_{rms} between the supply conductors or between either supply conductor and ground. A protective ground connection, through the grounding conductor in the power cord, is essential for safe operation.

Grounding the Product

This product is grounded through the grounding conductor of the power module power cord. To avoid electrical shock, plug the power cord into a properly wired receptacle before connecting to the product input or output terminals. A protective-ground connection by way of the grounding conductor in the power module power cord is essential for safe operation.

Without the protective ground connection, all parts of the product are potential shock hazards. This includes knobs and controls that may appear to be insulators.

Use the Proper Power Cord

Use only the power cord and connector specified for your product. Use only a power cord that is in good condition.

Use the Proper Fuse

To avoid fire hazard, use only the fuse specified for your product, matched by type, voltage rating, and current rating. Fuses are specified in Appendix C of this manual.

Do Not Operate Without a Cabinet

To avoid personal injury, do not remove covers or panels or operate this product without the protective covers installed.

Do Not Operate in Wet/Damp Conditions

To avoid electric shock, do not operate this product in wet or damp conditions.

Allow Proper Ventilation

Always allow air to flow freely through the cooling fins along the left and right sides of the TDC5.

Allow Adequate Clearance

Install the TDC5 with at least 3/4" of clearance above and below its case. When installing in a rack, it is advisable to leave a space of one rack unit above and below the TDC5.

Do Not Operate in Explosive Atmospheres

To avoid explosion, do not operate this product in an explosive atmosphere unless it has been specifically certified for such operation.

Service

For internal service and adjustment of the TDC5, contact your local Tektronix representative. *Only qualified personnel should perform service procedures.*



Preface

The TDC5 User Manual contains information necessary for daily use.

Manual Overview

Topics covered in this manual are as follows:

Getting Started includes a product description as well as installation and first-time turn-on procedures.

Operating Basics contains the functional overview, which describes the front- and rear-panel controls and connectors, and a tutorial, which guides the user through basic instrument operation.

Reference describes menu commands and provides a menu flow chart.

Appendix A provides instrument specifications, both electrical and mechanical.

Appendix B describes remote control interfaces.

Appendix C describes changing fuses and cleaning the product.

Appendix D contains the channel tables used in the TDC5.

Appendix E describes the remote commands.

Appendix F details remote interface.

Index appears at the end of the manual.

Introduction

The Tektronix TDC5 Tunable Down Converter is capable of converting any television RF signal in the range of 50 to 860 MHz into an IF signal of 45.75 MHz. The high performance of the conversion guarantees a measurement-quality signal after demodulation.

The TDC5 is designed for multichannel cable television applications. Its gain control system evaluates the incoming signals to determine the ideal compromise between optimum signal-to-noise ratio and minimum intermodulation distortion.

The TDC5 is 19" wide by one rack unit high.

Any of the four rear-panel RF inputs can be selected as the source signal to be output. The signal can be tuned by channel, by frequency, or by preset. As many as 200 presets can be stored and recalled with different configurations for input, tuning, and automatic gain control.

Most instrument functions can also be controlled through the remote interface. Remote connectors (9 pin and 25 pin) are available at the rear panel. The interface type, RS232C or RS485, is configured through the menu. User-defined addresses allow multiple units to be connected for remote control.

System Applications

The DS1200 Cable Television Demodulator System consists of a TDC5 Tunable Down Converter and a TDM5 Television Demodulator. The package provides accurate, tunable demodulation for cable television proof-of-performance testing, as well as operational applications, such as off-air pickups, translators, or videotaping of off-air signals. When used with a 1740A-Series Waveform/Vector Monitor or the 1780R-Series Video Measurement Set, the system can be used to make all of the FCC baseband proof-of-performance tests, as well as many others, such as depth-of-modulation and in-channel frequency response.

Standard Accessories

The following standard accessories are shipped with the TDC5. Tektronix part numbers are shown in parentheses.

Rackmount Hardware Kit

Standard North American Power Cord (161-0216-00)

10" Coaxial Cable, BNC, 50 Ω (012-0208-00)

250 V, 1 Amp Replacement Fuse – quantity of 2

Trim Adjustment Tool

User Manual (070-8993-00)

Installation

On receipt of the TDC5, open the box and verify that the accessory items listed on page 1–2 are included.

Save the shipping carton and packing materials in case it becomes necessary to ship the TDC5 to a Tektronix Service Center for service or repair. Packaging instructions are on page C–1.



WARNING. *Before proceeding, read the Safety Summary at the front of this manual.*

Electrical Installation

The TDC5 is designed to operate from a single-phase power source having one of its current-carrying conductors at or near earth ground (the neutral conductor). Only the line conductor is fused for over-current protection.

Systems that have both current-carrying conductors live with respect to ground (such as phase-to-phase on multiphase systems) are not recommended as power sources. A protective ground connection by way of the grounding conductor in the power cord is essential for safe operation.

Check to see if the TDC5 mains voltage setting matches your AC power source voltage. (In Figure 1–1, the arrow that points to the small rectangle indicates the mains voltage setting.) If it does **not** match, change the mains voltage setting as follows:

Changing the Mains Voltage

1. Disconnect the power cable from the TDC5.
2. Pull the voltage selector straight out of the rear panel, rotate it by 180°, then plug it back in. The fuses are automatically placed in the correct position for operation.
3. Referring to Figure 1-1, verify that the arrow pointing to the rectangle now indicates the correct voltage setting.
4. Reconnect the TDC5 to the AC power source.

Power On

Push the rear-panel Power switch to the 1 position (on). The green POWER indicator should be illuminated, and the front-panel display should show the current operating settings.

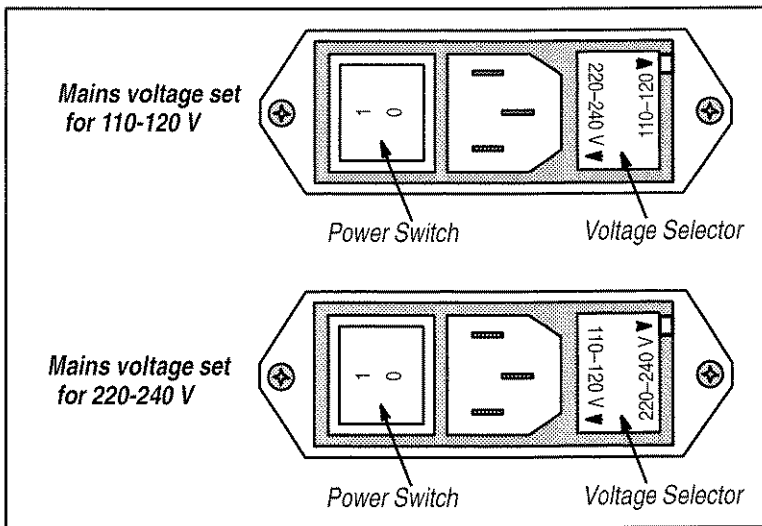

Figure 1-1: Rear-panel Input Connector

Rackmount Information

The TDC5 is 19" wide by 19.5" long, and one rack unit high. It is shipped with the hardware necessary to install it in a 19" rack.

Allowing Adequate Air Flow

To provide adequate air flow to the cooling fins along the left and right sides of the TDC5:

- Use the included rackmounting hardware, which is designed to allow proper air flow.
- Install additional components, such as combiners and netstrips, at the back of the racks only.
- Allow ventilation space on the left and right sides of the equipment rack.

It is advisable to leave about seven inches of space at the back of a rack. At the bottom and top of the rack, ventilation profiles should be installed to allow air to enter and leave the rack.

Cooling Fans

It is advisable to leave at least one rack unit of space above and below an installed unit. When five or more units are installed above one another, a fan is necessary. Its power depends on the number of units installed. For a rack containing 15 units with one unit of free space between each unit, an airflow of 300 m³/hour is required.

Air Temperature

When installed in a rack, the TDC5 should be operated in a constant room temperature of 15° to 35° C.

Rack Installation Procedure

Rackmounting hardware is included with each TDC5. Parts are included to accommodate racks with round, square, or threaded holes. Refer to Figure 1–2 while using this procedure.

1. If the provided runners are too long, saw off the portion beyond the notch as shown.
2. Connect the runners as shown. Do not tighten the bolts yet.
3. For racks with square holes, insert the adapters into the holes, then proceed to step 4.

NOTE. *The kit contains four sets of two blocks each. For racks with round or square holes, all eight blocks will be used to secure the runners to the chassis. For racks with threaded holes, only four blocks will be used, along with the 10–32 screws, washers, and nuts.*

4. For racks with round or square holes:
 - a. Mount the pairs of blocks on the front and back of each side of the rack as shown in the illustration.
 - b. Insert the screws but do not tighten yet.
 - c. Place a runner end between each set of two blocks, adjusting the length of the runners to fit the rack. Tighten the screws at the front and back of the rack.
5. For racks with threaded holes, mount a single block at the front and back corners of the rack. Insert the supplied 10–32 screws. Place a runner between each block and the rack, then install and tighten the 10–32 washers and nuts.
6. Tighten the nuts on the runners. Check that all screws and nuts have been carefully tightened.
7. Slide the TDC5 into the rack, making sure that the rack runners fit into the notch in the cooling fins (see Figure 1–2). The springs at the front of the TDC5 will click after they are past the front of the rack.
8. To remove the unit from the rack, press the springs and carefully pull the unit forward and out of the rack.

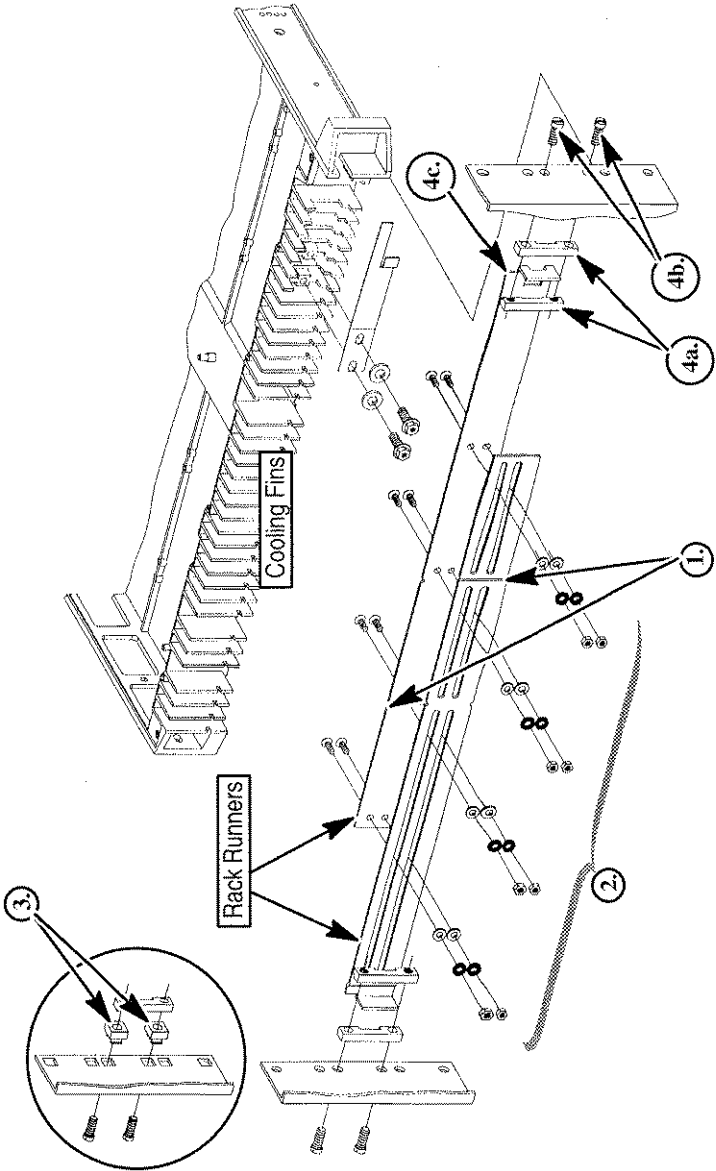

Figure 1-2: Installing Rackmount Hardware



Operator's Checkout Procedure

The television signal can be applied to any of the four RF INPUTS of the TDC5. The tuned signal at the output of the TDC5 will typically be connected to the input of a TDM5. The TDM5 converts the modulated picture signal to baseband video.

The output of the TDM5 can be viewed on a picture monitor or waveform monitor. Basic operation of the TDC5 and TDM5 can be verified using the following procedure.

1. Use a television signal from either cable feed or antenna. Connect the signal to one of the four RF INPUTS on the TDC5. Be sure that the input you are using is selected through the INPUT menu command (see Section 2).
2. Using the provided 50 Ω coaxial cable, connect the IF OUT signal from the TDC5 to the IF IN connector on the TDM5.
3. Connect the VIDEO OUTPUT signal of the TDM5 to the input of a picture monitor, waveform monitor, or other monitoring equipment. The Tektronix 1780R-Series or 1740A-Series can be used for this purpose.
4. Verify that the TDM5 automatic gain control is enabled (the front-panel LED labeled MAN GAIN should NOT be illuminated). The AGC is enabled/disabled through the menu (see Section 2).
5. Verify that the proper video signals are present on the monitoring equipment. If it is necessary to adjust the TDM5 video and audio output levels, refer to the TDM5 manual.



Functional Overview

Controls and Connectors

Front- and rear-panel controls, connectors, and indicators are described here, and illustrated in Figure 2-1.

1. **POWER.** The green LED is illuminated when power is present.
2. **Front-panel Display.** The two-line LCD display is used to show current operating settings, menu commands, and error messages.

When the TDC5 is in the standard operating mode, the latest settings for Frequency, Output, and Automatic Gain Control are displayed. When the instrument is in the menu mode, commands are displayed.

When a fault occurs, INTERNAL ERROR is displayed. If this happens, turn off the unit, wait a few seconds, and turn it on again. If it still does not work properly, contact Tektronix.

The display is adjustable. Refer to page C-2 for instructions.

3. **Left Key.** Use the left key (←) to page backwards through menu parameters displayed on screen, such as channel, frequency, or preset parameters. Press the enter key (↵) after changing a menu setting, otherwise pressing the left key will restore the previous setting and ignore the change.
4. **Down Key.** Use the down key (↓) to advance through menus and menu settings. Press the enter key (↵) after changing a menu setting, otherwise pressing the down key again will change to a different setting.
5. **Up Key.** Use the up key (↑) to go back through menus and menu settings. Press the enter key (↵) after changing a menu setting, otherwise pressing the up key again will change to a different setting.
6. **Enter Key.** Press the enter key (↵) to accept a change you have made to a menu setting, otherwise pressing the left or menu key

will reset to the previous setting, and pressing the up or down key will change to a different setting.

7. **MENU Key.** Press MENU to enter and exit the menu mode. Depending on the menu line, it will be necessary to press the key once, twice, or three times to exit the menu and return to instrument operating mode.

Press the enter key (↵) after changing a menu setting, otherwise pressing the menu key will restore the previous setting and ignore the change.
8. **Power Switch.** When set to on (1), the power switch turns on the TDC5. When the TDC5 is turned off (0), all settings and preset channels are retained in memory.
9. **Power Input Connector.** Accepts AC power cord assembly that is shipped with the product.
10. **Voltage Selector.** The position of the voltage selector determines the mains voltage setting. The mains fuses (for 110-120 V and 220-240 V operation) are also located here. Fuse replacement is described in Appendix B, and instructions for changing the mains voltage setting are on page 1–4.
11. **RS485 Connector.** This 9-pin D-type subminiature connector allows for remote control of most front-panel functions via RS485 communication. Turn off the TDC5 before connecting or disconnecting cables. RS485 interface is enabled by menu command.
12. **RS232 Connector.** This 25-pin D-type subminiature connector allows for remote control of most front-panel functions via RS232 communication. Turn off the TDC5 before connecting or disconnecting cables. RS232 interface is enabled by menu command.
13. **IF OUT.** The IF output connector is compensated in 50 Ω. Specifications for the IF output are given in Appendix A.
14. **RF Inputs.** Four different RF input signals can be accommodated by these four inputs. Any one of the four RF inputs can be selected for output through the use of menus, as described on page 2–10. The connectors are compensated in 75 Ω. Specifications for the RF input are given in Appendix A.

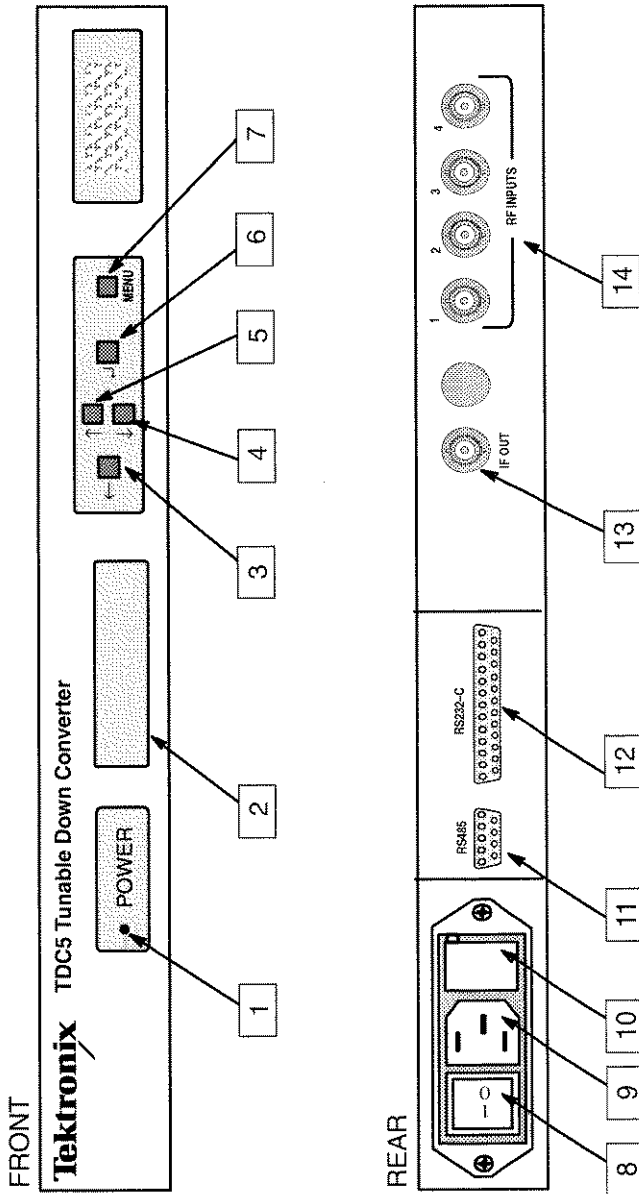

Figure 2-1: TDC5 Front and Rear Panels



Operating Procedures

The TDC5 will typically be used as part of a system that includes the Tektronix TDM5 Demodulator. The system may also include a Tektronix 1740A–Series Waveform / Vector Monitor or 1780R–Series Video Measurement Set. Typical equipment hookups can be found in the Operator’s Checkout Procedure on page 1–9.

The TDC5 menus allow you to define current instrument settings and to store and recall instrument setups through the use of presets. All settings and preset channels are saved in memory when the TDC5 is turned off.

The following procedures use factory settings for the illustrations; your display will vary if settings have been changed. To assist in visualization, the entire menu command structure is illustrated, with a box around the two lines of text that are seen on the LCD screen.

No input signal is required for the following procedures. Please read the Safety Summary at the front of the manual before proceeding.

Instrument Power On

1. Apply an appropriate power source to the TDC5 and turn on the instrument power.
2. The front-panel LCD firmware will briefly show the Tektronix identification and firmware version number, then display the instrument operating parameters. (The LCD display is adjustable for best viewing; refer to page C–2 for instructions.)

Enter the Menu

1. Press the MENU key to enter the menu.

A portion of the front-panel LCD display should be flashing, indicating that changes can now be made. The menu display may vary, depending on the current instrument settings, but should be similar to Figure 2–2. (You will actually see only the two lines that are boxed in the illustration, and the upper left entry will be flashing.)

NOTE. *These procedures require you to be in the menu mode. However, in normal use, you would make change(s), then return to the instrument operating mode.*

You can exit the menu at any time by pressing the MENU key again. Depending on the level of submenu selected, the key must be pressed once, twice, or three times to return to instrument operating mode. Note that the display does not flash in the operating mode.

NOTE. *After changing a menu setting in the following procedures, you will be instructed to "press the enter key to accept the change." This means that if the enter key is not pressed first, pressing the left or MENU key will reset the change, and pressing the up or down key will change to a different setting.*

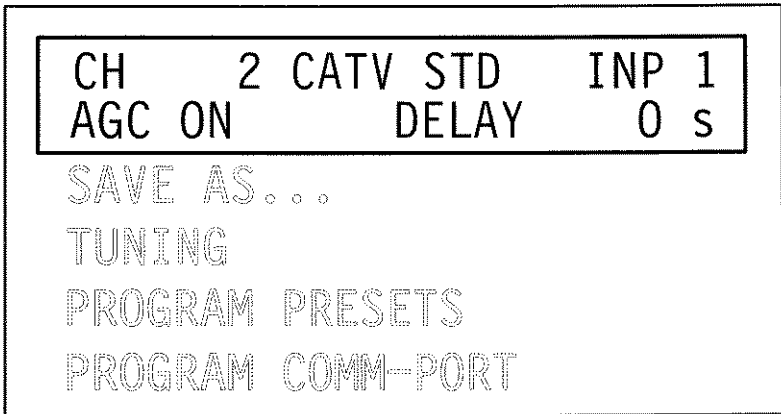

Figure 2-2: The TDC5 Display After Selecting MENU

Select Tuning Method (TUNING)

1. Press the down key to advance through the menu commands until the word TUNING is flashing. The display will be similar to Figure 2-3.
2. Press the enter key. The word CHANNEL TABLE will flash, and the display will be similar to Figure 2-4.
3. Press the enter key again. The words to the right of CHANNEL TABLE will flash. Use the up or down key to select **FREQ TUNE**, **CATV**, **BROADCAST**, or **HRC**. Do not select **PRESETS** at this time; they will be discussed in a later step.
4. Press the enter key to accept the selection. Press the **MENU** key to return to the main menu.

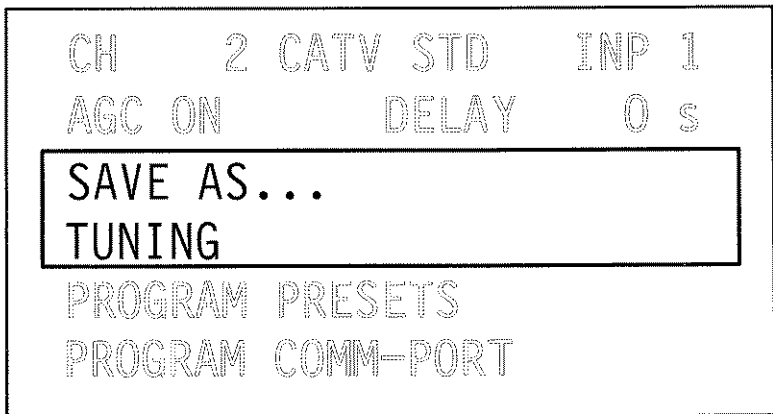

Figure 2-3: The TDC5 Display After Advancing to TUNING

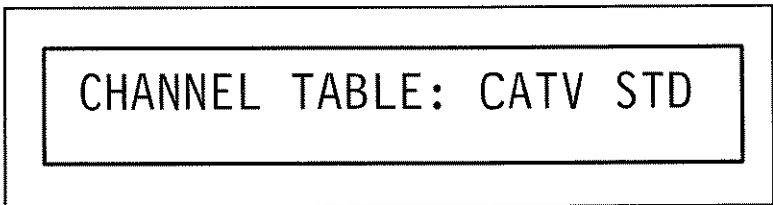

Figure 2-4: The TDC5 Display After Selecting TUNING

Tune (FREQ or CH)

1. The tuning method you selected in the previous step affects the way the first line of the main menu will appear. If you selected FREQUENCY, the menu will begin with FREQ; if you selected one of the channel tables, it will begin with CH. (Selecting presets will be described later in this section.)

NOTE. *When tuning the TDC5 by frequency or channel, a special feature allows you to make measurements quickly. When you select a new frequency or channel, the new setting automatically becomes effective after two seconds. This is referred to as the “quick check” mode.*

Measurements can be made in the quick check mode, without first pressing the enter key. However, pressing the left key or MENU key will reset to the previous frequency or channel, and pressing the up or down key will select a new frequency or channel.

When you are satisfied with the new frequency or channel and want to keep the setting, press the enter key. If you wish to return to the instrument operating mode, press the MENU key now. Note that the display does not flash in the operating mode.

2. For frequency tuning, use the up or down key to move through the menu until FREQ is flashing. The display should be similar to Figure 2-5. For channel tuning, proceed to step 3.
 - a. Press the enter key; the number to the right of FREQ flashes.
 - b. Use the up or down key to change the frequency within the range of 50 MHz to 860 MHz. A single press of the key causes a 25 kHz change, and holding the key causes a continuous frequency value change in 25 kHz steps. Continuing to hold the key for 7 seconds causes 1 MHz steps, and for 14 seconds causes 5 MHz steps.
 - c. The new frequency setting automatically becomes effective after two seconds. This is referred to as the

“quick check mode,” and measurements can be made in this mode.

- d. If you want to keep this new frequency setting, press the enter key. If the enter key is not pressed, then pressing the left or MENU key will reset to the previous frequency value, and pressing the up or down key will change to a different frequency.
 - e. For this procedure, you will remain in the menu mode. In everyday use, after you have made the desired change(s) and pressed the enter key, use the MENU key to return to the instrument operating mode. Note that the display does not flash in operating mode.
3. For channel table tuning, return to the TUNING menu and select CATV STD, HRC, or BROADCAST. This will cause the menu to begin with CH. Use the up or down key to sequence through the menu until CH is flashing. The display will be similar to Figure 2-2.
 - a. Press the enter key. The number to the right of CH will flash.
 - b. Use the up or down key to change to the desired channel. Appendix D shows the three available channel tables.
 - c. The new channel selection automatically becomes effective after two seconds. This is referred to as the “quick check mode,” and measurements can be made.
 - d. If you want to keep this new channel setting, press the enter key. If the enter key is not pressed, then pressing the left or MENU key will reset to the previous channel, and pressing the up or down key will change to a different frequency.
 - e. For this procedure, you will remain in the menu mode. In everyday use, after you have made the desired change(s) and pressed the enter key, use the MENU key to return to the instrument operating mode. Note that the display does not flash in operating mode.

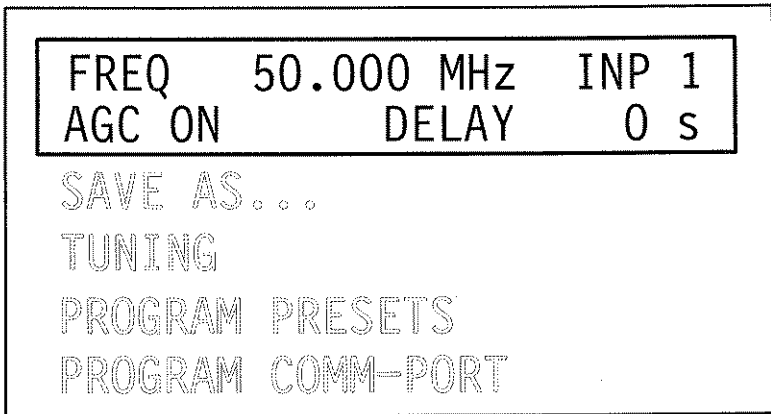

Figure 2-5: Tuning by Frequency

Input (INP)

1. Press the up or down key to sequence through the menu until INP is flashing. The display will be similar to Figure 2-5. (The first line may vary, depending on the tuning selection.)
2. Press the enter key. The input number will now flash. Use the up or down key to select an input between 1 and 4. This will determine which rear-panel input signal is used for the IF OUT.
3. Press the enter key to accept the change.

Automatic Gain Control (AGC)

1. The AGC can be set to ON or OFF. (AGC function is described in detail on page 3-5.)
2. To change the AGC setting, press the up or down key to move through the menu until AGC is flashing. The display will be similar to Figure 2-5.
 - a. Press the enter key. The word to the right of AGC will now flash.
 - b. Use the up or down key to change the setting.

- c. Press the enter key to accept the change.

Delay (DELAY)

1. When AGC is ON, the word DELAY will appear in the menu. Press the up or down key to sequence through the menu until DELAY is flashing. The display will be similar to Figure 2–5. (The first line may vary, depending on the tuning selection.)
2. Press the enter key. The number to the right of DELAY will now flash. Use the up or down key to set the delay between 0 and 120 seconds. See page 3–6 for details on this setting.
3. Press the enter key to accept the change.

Attenuation (RF, IF, TOTAL)

1. When AGC is OFF, the word ATTENUATION will appear in the menu. Press the up or down key to sequence through the attenuation options (total, IF, and RF). The display will be similar to Figure 2–6.
2. The total attenuation value represents RF attenuation + IF attenuation. A change to any of these values will affect one or both of the other values. Refer to page 3–6 for information about this relationship. Attenuation settings can be changed as follows:
 - a. Press the enter key. The total attenuation value will flash. Use the up or down key to set the total attenuation between 0 and 60 dB. Press the enter key to accept the change.
 - b. Advance until the IF attenuation value is flashing, then press the enter key. Use the up or down key to set the attenuation between 0 and 15 dB. Press the enter key to accept the change.
 - c. Advance until the RF attenuation value is flashing, then press the enter key. Use the up or down key to set the attenuation between 0 and 45 dB. Press the enter key to accept the change.

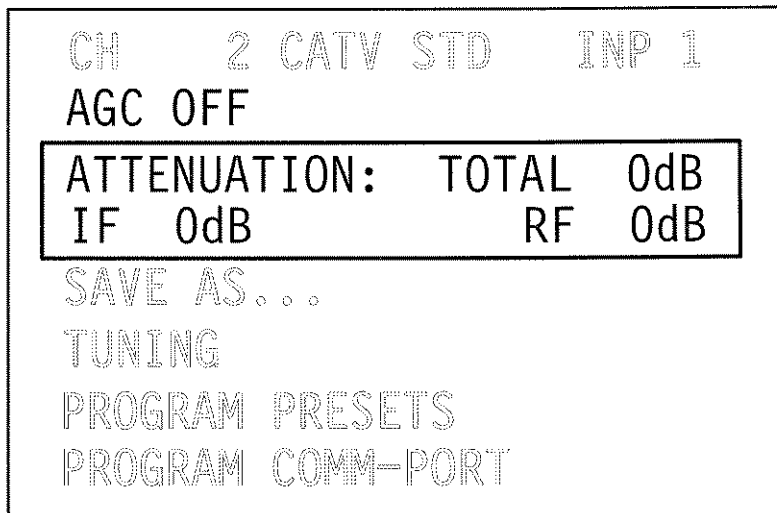

Figure 2-6: Setting Attenuation (AGC OFF)

Storing Presets (PROGRAM PRESETS and SAVE AS...)

PROGRAM PRESETS allows you to modify preset information. SAVE AS... allows you to save the current operating parameters to a preset for later recall. All 200 presets have identical factory settings.

1. Use the up or down key to sequence through the menu until PROGRAM PRESETS is flashing. Press the enter key. The display will be similar to Figure 2-7, with the preset number flashing.
 - a. Use the up or down key to select Preset 1 (or any preset number between 1 and 200) for modification. Press the enter key; the frequency will now flash.
 - b. Use the up or down key to select a frequency between 50 and 860 MHz. Press the enter key to store the selection. Now INPUT will flash.

- c. Press the enter key, and the number to the right of INPUT will flash. Use the up or down key to select which input (1 through 4) will be used when Preset 1 is selected. Press the enter key; now AGC will flash. (AGC function is described on page 3–5.)
- d. Press the enter key. Now ON will flash. Use the up or down key to change the setting to OFF. Press the enter key to accept the selection. The display will look like Figure 2–8, with IF flashing.
- e. Press the enter key, and the 0 will flash. Use the up or down key to select the IF attenuation value that will be in effect when Preset 1 is used. Press the enter key to accept the selection. RF will flash. Modify the RF attenuation value in the same way as the IF value.

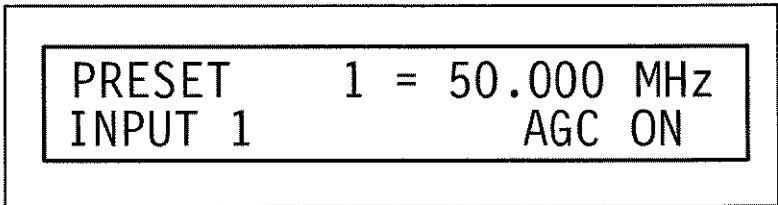

Figure 2–7: Preset Default Settings

- 2. To save current instrument settings to a preset, use the up or down key to move through the menu until SAVE AS... is flashing.
 - a. Press the enter key. If TUNING is set to PRESET, the display will be similar to Figure 2–7, with the preset number flashing. If TUNING is set to CH or FREQ, the procedure is the same, but the display will differ slightly.
 - b. Use the up or down key to select a preset number between 1 and 200.
 - c. Press the enter key to store the current instrument settings at that preset. Press the MENU key to return to the main menu.

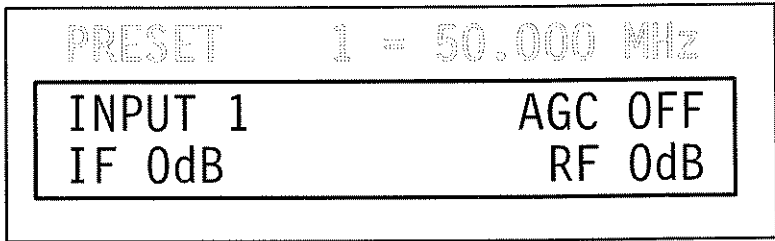

Figure 2-8: Programming a Preset (AGC OFF)

Recalling Presets (Tuning by Preset)

1. Using the SAVE AS... or PROGRAM PRESETS command as described in the previous step, save the desired instrument operating information to a preset. Press the MENU key to exit the menu.
2. Make a note of the current instrument operating information that is displayed on the LED readout.
3. Press the MENU key to enter the menu again.
4. Advance through the menu until TUNING is flashing. The display will be similar to Figure 2-3.
5. Press the enter key. The word CHANNEL TABLE will flash, and the display will be similar to Figure 2-4.
6. Press the enter key again. The word(s) to the right of CHANNEL TABLE will flash. Use the up or down key to select PRESET.
7. Press the enter key to accept the selection. Press MENU to return to the main menu.
8. Use the down key to sequence through the menu until PR flashes. The display will be similar to Figure 2-9.
 - a. Press the enter key. The preset number to the right of PR will flash.

- b. Use the up or down key to select the preset number that you saved in step 1. Press the enter key, and the operating parameters of the TDC5 will be changed according to the selected preset. Note that the “quick check mode” is not active for presets; the enter key must be pressed before the change is effective.
 - c. At this point, you can return the instrument to the factory default settings by recalling a preset that you have not modified.
9. If desired, proceed to the TUNING menu and return the instrument to the frequency or channel tuning mode, then press the MENU key to exit the tuning submenu.

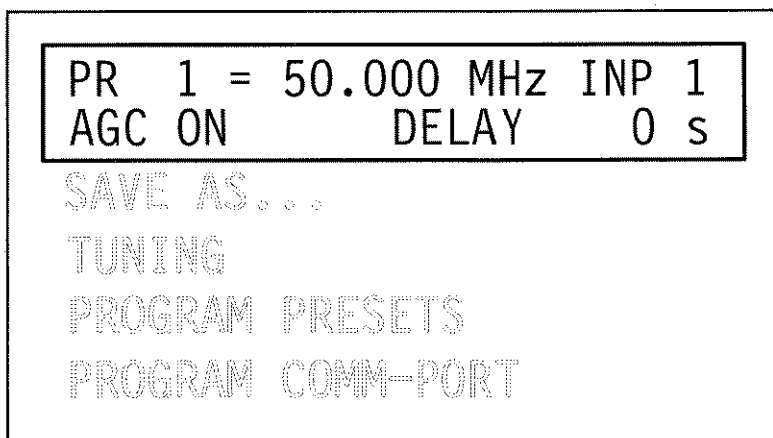

Figure 2-9: Recalling a Preset

Set Up Remote Interface (PROGRAM COMM-PORT)

The following procedure allows you to change the way the rear-panel remote control interface will work.

1. Use the down key to advance to PROGRAM COMM-PORT. Press the enter key. The display will look like Figure 2-10.

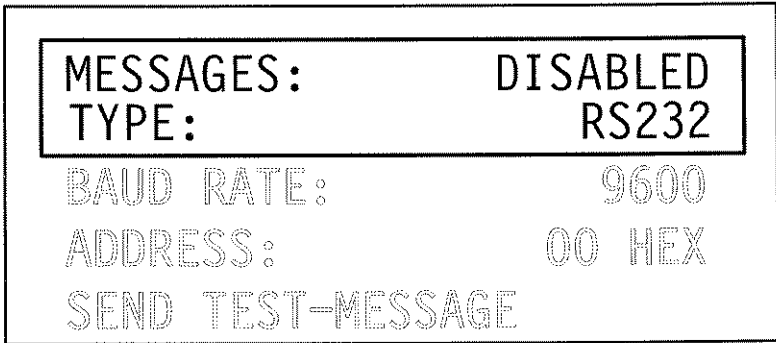

Figure 2-10: Programming the Communications Interface

2. Use the down key to advance until ADDRESS is flashing. Press the enter key, and the hex code number to the right of ADDRESS will flash.
3. Use the up or down key to select an address between 00 hex and 3F hex. Press the enter key. This will establish the address of this TDC5 to be used when controlling it from a PC. Be sure that each TDC5 that is attached to the same PC has a unique address.
4. Press the MENU key to return to the main menu.

Menu Overview

The TDC5 has several user-definable operating parameters. These are configured through the menu (see Figure 3-1). Configurable items include: input (1, 2, 3, or 4), instrument tuning method (frequency, channel, or preset), automatic gain control, delay, attenuation, remote interface, and store and recall of presets.

Quick Guide

The TDC5 can be configured as follows:

- Press the front-panel MENU key to access the main menu commands, which will appear on the front-panel LCD display.
- Use the up and down keys (\uparrow and \downarrow) to move through the menu until the desired command flashes (such as **INP** for input).
- Press enter (\downarrow). Now the actual value or function will flash (such as **1** for input 1). [If a submenu is present, press the up and down keys (\uparrow and \downarrow) until the desired submenu item is flashing, then press enter (\downarrow) again.]
- Use the up and down keys (\uparrow and \downarrow) to change the value as desired (such as changing the input **1** to input **2**).
- The value will continue to flash, and can be changed again with the up and down keys (\uparrow and \downarrow), until you press enter (\downarrow).
- For frequency or channel tuning mode, two seconds after tuning with the up or down key (\uparrow or \downarrow), the new frequency or channel becomes effective. This is referred to as the “quick check mode.” If desired, measurements can be made in this mode, before pressing enter (\downarrow). To keep the new frequency or channel setting, however, you must press the enter key (\downarrow). If the enter key (\downarrow) is not pressed, then pressing the MENU key or left key (\leftarrow) will reset to the previous setting.
- To exit the menu, press the front-panel MENU key. From a submenu, it may be necessary to press the MENU key twice or three times to return to instrument operating mode.

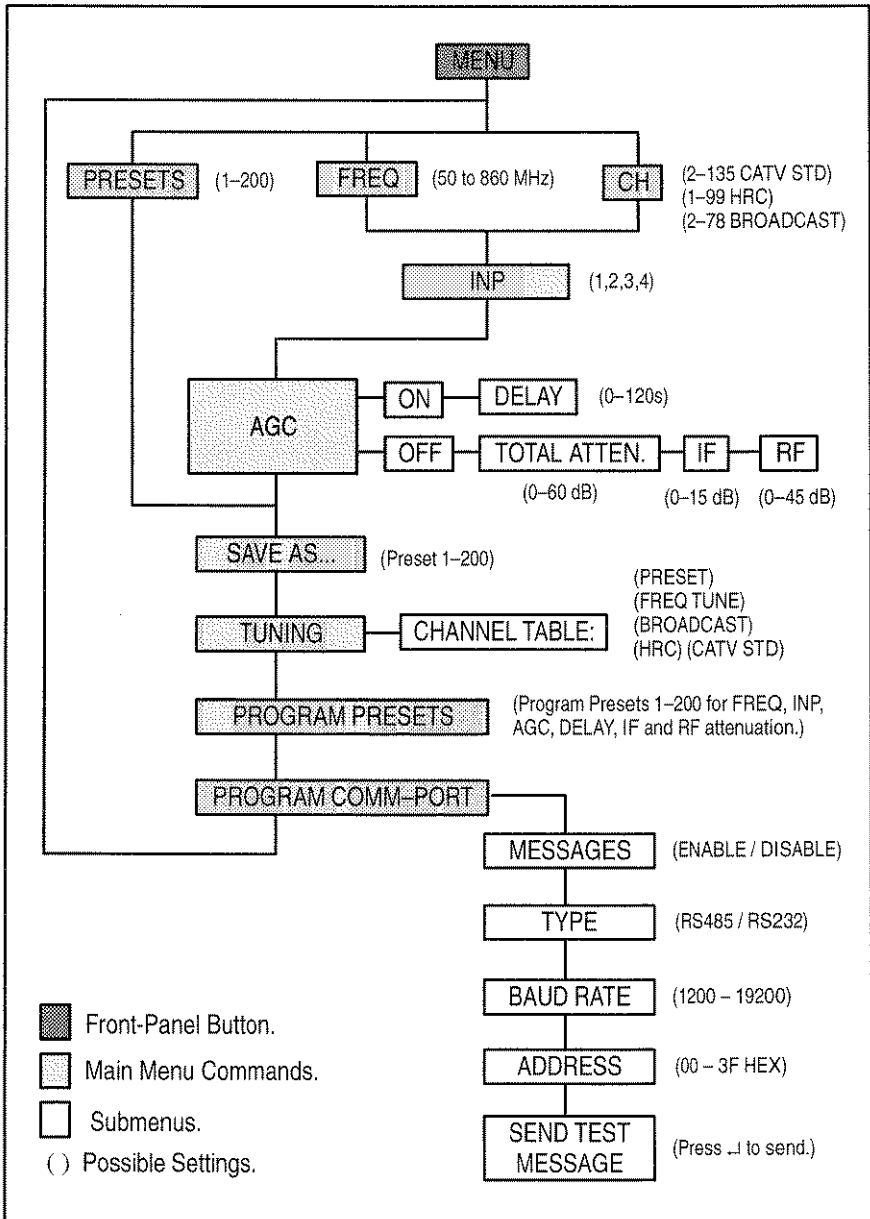

Figure 3-1: TDC5 Menu Hierarchy

Menu Reference

NOTE. BEFORE PROCEEDING, READ THE MENU OVERVIEW ON PAGE 3-1. If desired, refer also to step-by-step procedures beginning on page 2-5.

The following instructions require that you press the front-panel MENU key before proceeding and again when finished, to enter and exit the menu.

*The menu commands are presented here in the order that they appear on the TDC5 display. The first line of the menu begins with **FREQ**, **CH**, or **PR**, depending on the setting of the **TUNING** command.*

Frequency (FREQ)

The frequency command allows you to tune the input signal by frequency, from 50-860 MHz. Frequency settings can also be stored in the presets (see **SAVE AS...** or **PROGRAM PRESETS**).

The frequency command appears as **FREQ** in the menu display, and is present only if selected through the tuning command. To change the frequency setting, advance through the menu commands until **FREQ** flashes, then press the enter key. The frequency setting will flash (the number to the right of **FREQ**). Use the up or down key to change the frequency within the range of 50 MHz to 860 MHz. A single press of the key causes a 25 kHz change, and holding the key causes a continuous frequency value change in 25 kHz steps. Continuing to hold the key for 7 seconds causes 1 MHz steps, and for 14 seconds causes 5 MHz steps.

New frequencies automatically become effective after a delay of approximately 2 seconds. This is referred to as the “quick check mode.” Measurements can be made in this mode, if desired. However, to keep the new frequency setting, the enter key must be pressed. Otherwise, pressing the left key or **MENU** key will reset the frequency to the previous value, and pressing the up or down key will change to a different frequency.

After pressing the enter key, you can press the MENU key to return to the instrument operating mode, or remain in the menu mode and modify additional instrument parameters.

NOTE. *When the enter key is pressed, the RF input is interrupted for a short period. The RF input is restored at the new frequency.*

Channel (CH)

The channel command allows you to tune the signal by channel, according to the channel table chosen through the tuning command. This information can also be stored in the presets for later Recall (refer to the SAVE AS... or PROGRAM PRESETS commands).

Possible channel settings are: 2–135 CATV STD; 1–99 HRC; 2–83 Broadcast. Channel tables are shown in Appendix D.

The channel command is available only if one of the channel tables is selected through the tuning command. It appears as CH in the menu display, and is followed by the currently selected channel number and channel table. To change the channel table, refer to the tuning command instructions.

To change the channel number, advance through the menu commands until CH flashes, then press the enter key. The channel number will flash; use the up and down keys to change the channel.

After two seconds, the new channel will automatically become effective. This is referred to as the “quick check mode.” Measurements can be made in this mode, if desired. However, to keep the new channel setting, the enter key must be pressed. Otherwise, pressing the left key or MENU key will reset to the previous channel, and pressing the up or down key will change to a different channel.

After pressing the enter key, you can press the MENU key to return to the instrument operating mode, or remain in the menu mode and modify additional instrument parameters.

Presets (PR)

The preset command allows you to reset the current instrument operating parameters to information stored in any of the 200 presets. Use the SAVE AS... or PROGRAM PRESETS commands to store or modify information in the presets. Recalling a preset that has not been modified will return the current instrument operating status to the factory settings.

The preset command is preset only if PRESETS has been selected through the tuning command. It appears as PR in the menu display, and is followed by the currently selected preset number and its settings. To change the preset number, advance through the menu commands until PR is flashing, then press enter. The preset number to the right of PR will flash; use the up and down keys to change to another preset between 1 and 200. The new preset number and its settings will be displayed. When the desired preset is displayed, you must press the enter key to accept the new preset and change the current instrument operating status to match the preset. Note that the "quick check mode" is not active for presets.

Input

The input command allows you to specify which input will be used. This information can also be stored in the presets for later Recall (refer to the SAVE AS... or PROGRAM PRESETS commands).

Input appears on the first line of the menu as INP, followed by the input number. To change the input number, advance through the menu commands until INP is flashing, then press the enter key. The input number to the right of INP will flash; use the up and down keys to change the number. Press the enter key to accept the change.

AGC

The Automatic Gain Control circuitry contains three stages: two in the RF chain and one in the IF chain. The first RF AGC circuit, at the input of the unit, is used for an adjustment of up to 35 dB in 5 dB steps. The second RF AGC enables 10 dB in 1 dB steps. The third IF AGC covers up to 15 dB in 1 dB steps. The delay, IF attenuation and RF attenuation (but not total attenuation) can also be stored in

the presets for later recall (refer to the SAVE AS... or PROGRAM PRESETS command).

AGC appears on the second line of menu commands, followed by the status (ON or OFF). To change the AGC status, advance through the menu commands until AGC flashes, then press the enter key. The AGC status will then flash; use the up and down keys to change the status, then press the enter key to make the change effective. If AGC is on, the DELAY command will be displayed; if AGC is OFF, the ATTENUATION commands will be displayed.

Attenuation or delay can be changed as described in the following paragraphs.

Delay

When AGC is on, the circuits enabling 1 dB adjustment are always in action. The first RF AGC circuit, enabling AGC in 5 dB steps, can be configured for a delayed action as follows.

The DELAY command is only available when AGC is on. Advance until the DELAY command flashes. Press the enter key; this will cause the delay time to flash. Use the up and down keys to choose a new delay time between 0 and 120 seconds. The setting can be changed again, and will continue flashing, until the enter key is pressed to register the change. To return to the main menu, press the MENU key.

Total Attenuation

The total attenuation value represents RF attenuation + IF attenuation.

When AGC is off, the ATTENUATION commands will be available; press the up or down key until TOTAL flashes. Press the enter key, causing the value to the right of TOTAL attenuation to flash. Use the up and down keys to choose an attenuation value between 0 and 60 dB. The setting can be changed again, and will continue flashing, until the enter key is pressed. To return to the main menu, press the MENU key.

IF Attenuation

When changing IF attenuation, the total attenuation typically remains constant, and the RF attenuation is automatically adjusted to maintain the relationship: Total attenuation = IF attenuation + RF attenuation. If this is not possible, then the total attenuation will be adjusted.

When AGC is off, the ATTENUATION commands will be displayed; press the up or down key until IF flashes. Press the enter key, causing the attenuation value to the right of IF to flash. Use the up and down keys to choose an attenuation value between 0 and 15 dB. The setting can be changed again, and will continue flashing, until the enter key is pressed. To return to the main menu, press the MENU key.

RF Attenuation

When changing RF attenuation, the total attenuation typically remains constant, and the IF attenuation is automatically adjusted to maintain the relationship: Total attenuation = IF attenuation + RF attenuation. If this is not possible, then the total attenuation will be adjusted.

When AGC is off, the ATTENUATION commands will be displayed; press the up or down key until RF flashes. Press the enter key, causing the attenuation value to the right of RF to flash. Use the up or down key to choose an attenuation value between 0 and 45 dB. The value can be changed again, and will continue flashing, until the enter key is pressed. To return to the main menu, press the MENU key.

Save As...

This command saves the current instrument settings at a specified location (a preset between 1 and 200). The saved settings will be restored when that preset channel is selected through the PRESETS menu command (PR).

To save information to a preset, advance through the menu until SAVE AS... flashes, then press the enter key. The preset number will flash. Use the up and down keys to select the desired preset, then

press the enter key to save the current settings to it. Information previously stored in that preset will be overwritten.

Tuning

The selection made here affects the way the first line of the main menu will appear. Selecting FREQUENCY will cause the line to begin with **FREQ**. Selecting PRESETS will cause it to begin with **PR**, and selecting a channel table will cause it to begin with **CH**.

To change the tuning method, advance through the menu until **TUNING** flashes. Press the enter key; **CHANNEL TABLES** will appear, followed by the current selection. Press the enter key again to make the current selection flash, then use the up or down key to change the selection. Press enter to register the change, then press the front-panel **MENU** key to return to the main menu.

Program Presets

The **PROGRAM PRESETS** command allows you to specify frequency, input, and AGC information in a preset without affecting current instrument settings.

To program a preset, advance through the menu until **PROGRAM PRESETS** flashes, then press the enter key. The preset number will flash; use the up and down keys as desired to change to a preset between 1 and 200. The preset number can be changed again, and will continue flashing, until the enter key is pressed. When the enter key is pressed, **FREQ** (the frequency command) will be displayed. Select Frequency, Input, and AGC settings as described earlier in this discussion, pressing the enter key each time to register the changes.

Program Comm-Port

The TDC5 can be remotely controlled through a PC, using RS232 and (if necessary) a modem link. However, if several units will be remotely controlled at the same remote site, use an RS485 connection with a communication box. Before using the RS232 or RS485 interface, appropriate comm-port settings must be selected.

First, advance through the menu until PROGRAM COMM-PORT flashes, then press the enter key. Five different topics can now be accessed with the up and down keys. The following paragraphs describe each topic. After making changes, press the MENU key to return to the main menu.

Messages

The TDC5 can send messages to the PC. It is possible to change the message mode to disable this link. The PC would still control the TDC5, however.

After selecting PROGRAM COMM-PORT, press the up or down key until MESSAGES flashes. Press the enter key and the mode (enable or disable) will flash. Use the up or down key to change the mode, then press enter to register the change.

Type

The communication type can be set for RS232 or RS485. A direct link between a TDC5 and a PC uses RS232 interface. When several units will be remotely controlled by a PC, use a communication box and RS485 interface.

After selecting PROGRAM COMM-PORT, press the up or down key until TYPE flashes. Press the enter key, and the communication type (RS485 or RS232) flashes. Use the up or down key to change the setting, then press enter to make the change effective.

Baud Rate

The baud rate can be set to 1200, 2400, 4800, 9600, or 19200 baud. Select the baud rate according to the device that will be connected to the TDC5. For a direct link between the TDC5 and a PC, select identical baud rates for both units. For communication via a communication box, select the baud rate according to the units connected via RS485 (all units must have the same baud rate). The communication link between the PC and the communication box via a telephone modem can be set to another baud rate.

After selecting PROGRAM COMM-PORT, press the up or down key until the words BAUD RATE are flashing. Press the enter key and

the value flashes. Use the up or down key to chose 1200, 2400, 4800, 9600, or 19200 baud, then press enter to register the change.

Address

The TDC5 address can be used by a connected PC to address and control the TDC5. Multiple units can be connected to one PC, but each address in the remote configuration must be unique.

To assign an address, select PROGRAM COMM-PORT and press the up or down key until ADDRESS flashes. Press the enter key and the hex code flashes. Use the up or down key to chose an address between 00 and 3F hex, then press enter to accept the address.

Send Test Message

This command allows you to check the link between the TDC5 and the PC by sending a test message.

After selecting PROGRAM COMM-PORT, press the up or down key until MESSAGE flashes. Press the enter key to send the message.

Appendix A: Performance Specification

Performance Requirement. All Performance Requirements in the specification tables are identified with **REQ**, and can be assured by completing the Performance Check Procedure. Allow a warm-up time of 20 minutes.

Performance Requirements in the electrical specifications are valid over an ambient temperature range of 15° C to 35° C. Test equipment used to verify Performance Requirements must be calibrated and working within its specified limits.

Reference Information. Information that amplifies a performance requirement or is of special importance is indicated by **RI**. There is no need to check these items to a specific tolerance.

Electrical Specification

Table A-1: RF Input

CATEGORY	DESCRIPTION
Input Level	<p>REQ: -10 dBmV to +60 dBmV (single channel).</p> <p>RI: +10 dBmV to +60 dBmV for optimum signal-to-noise performance.</p> <p>RI: Four switchable inputs.</p>
Input Impedance	<p>RI: 75 Ω.</p>
Return Loss	<p>REQ: \geq 10 dB with 0 dB Input attenuation.</p> <p>REQ: \geq 15 dB with frequencies \leq 470 MHz and input attenuation \geq 12 dB.</p> <p>REQ: \geq 12 dB with frequencies $>$ 470 MHz and input attenuation \geq 10 dB.</p>
Frequency Range	<p>REQ: 50 MHz to 860 MHz.</p>

Table A-1: RF Input (Cont.)

CATEGORY	DESCRIPTION
Channel Tables	<i>RI:</i> North American Cable TV Standard, Broadcast VHF and UHF (through channel 78), and HRC channel tables.
RF Attenuator	<i>RI:</i> 0 to 45 dB in 1 dB steps.
Noise Figure	<i>RI:</i> Typically ≤ 9 dB VHF and ≤ 11 UHF.

Table A-2: IF Output

CATEGORY	DESCRIPTION
Output Level	<i>REQ:</i> +35 dBmV. <i>RI:</i> Input level $\geq +10$ dBmV and AGC automatic. <i>REQ:</i> +5 dBmV. <i>RI:</i> Input level of -20 dBmV (one channel).
Output Impedance	<i>RI:</i> 50 Ω .
Output Frequency	<i>RI:</i> 45.75 MHz for video carrier. <i>RI:</i> 41.25 MHz for audio carrier.
Return Loss	<i>REQ:</i> ≥ 15 dB. <i>RI:</i> From 40.25 MHz to 46.75 MHz.
Amplitude Response	<i>REQ:</i> ± 0.5 dB from 35.75 to 47.25 MHz.
Group Delay Error	<i>REQ:</i> ≤ 10 ns from 35.75 MHz to 47.25 MHz.
Frequency Variation	<i>RI:</i> ≤ 20 ppm.

Table A-2: IF Output (Cont.)

CATEGORY	DESCRIPTION
IF Attenuator	<i>RI:</i> 0 to 15 dB in 1 dB steps.
Spurious Output	<i>REQ:</i> \geq 65 dB below video carrier.

Table A-3: Power Requirements

CATEGORY	DESCRIPTION
Line Voltage Ranges	<i>REQ:</i> 110 VAC \pm 20%. <i>REQ:</i> 220 VAC \pm 20%.
Power Consumption	<i>REQ:</i> 60 VA maximum.
Line Frequency	<i>REQ:</i> 48 Hz to 62 Hz.

Environmental Characteristics

Table A-4: Environmental Characteristics

CATEGORY	DESCRIPTION
Operating Temperature	<i>REQ:</i> 15° C to 35° C.
Storage Temperature	<i>REQ:</i> -20° C to 80° C.
Operating Altitude	<i>REQ:</i> 15,000 feet maximum.
Storage Altitude	<i>REQ:</i> 50,000 feet maximum.

Physical Characteristics

Table A-5: Physical Characteristics

CATEGORY	DESCRIPTION
Dimensions	<i>REQ:</i> Height: 1.75 inches (44.5 millimeters). Width: 19.0 inches (483 millimeters). Depth: 19.5 inches (496 millimeters).
Weight	<i>REQ:</i> Net Weight: 18.3 pounds (8.3 kilograms).

Appendix B: Remote Control



CAUTION. Do not connect or disconnect cables while the TDC5 is on. Before remotely controlling the TDC5, select the correct comm-port settings.

RS232 Communication

The connector is a 25-pin subminiature D-type with male contacts, and is accessible at the rear panel of the TDC5. (See Table B-1 and Figure B-1.) Most front-panel functions are available through the RS232 remote interface. The RS232 interface is enabled through the menu. Appendix E describes the remote commands, and Appendix F tells how to program sequences of commands through the PC.

Table B-1: RS232 Pin Connections

Pin	Function	Pin	Function
1	Chassis Ground	14	Not Used
2	TXD	15	Not Used
3	RXD	16	Not Used
4	RS	17	Not Used
5	CTS	18	Not Used
6	Not Used	19	Not Used
7	Signal Ground	20	DTR
8	DCD	21	Not Used
9	Not Used	22	Not Used
10	Not Used	23	Not Used
11	Not Used	24	Not Used
12	Not Used	25	Not Used
13	Not Used		

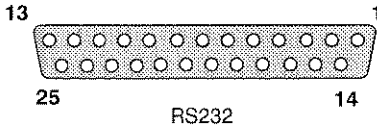

Figure B-1: Rear-panel RS232 Connector

RS485 Communication

The connector is a 9-pin subminiature D-type with male contacts, and is accessible at the rear panel of the TDC5. (See Table B-2 and Figure B-2). The RS485 interface is enabled through the menu.

Table B-2: RS485 Pin Connections

Pin	Function	Pin	Function
1	Chassis Ground	6	Not Used
2	TXD	7	Signal Ground
3	RXD	8	Not Used
4	TXA	9	Not Used
5	RXA		

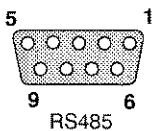

Figure B-2: Rear-panel RS485 Connector

Appendix C: Service



CAUTION. *Be sure that power is not supplied to the TDC5 while performing any procedures in this section.*

This section contains instructions for user and preventive maintenance, and for adjusting the display.

If the instrument does not function properly, contact Tektronix about service.

Packaging for Shipment

If it becomes necessary to ship the TDC5 to a Tektronix Service Center, follow these instructions:

1. Write the following on a tag attached to the product: the product owner, complete address and phone number of someone at your firm who can be contacted, the product serial number, and a description of the required service.
2. Repackage the product in the original packaging materials. If they are not available, follow these directions:
 - a. Obtain a carton of corrugated cardboard having inside dimensions six or more inches greater than the dimensions of the instrument. Use a shipping carton that has a test strength of at least 275 pounds.
 - b. Surround the product with a protective bag (antistatic preferred).
 - c. Pack dunnage or urethane foam between the product and the carton. If you use Styrofoam kernels, overfill the box and compress by closing the lid. There should be three inches of tightly packed cushioning on all sides of the instrument.
3. Seal the carton with shipping tape, industrial stapler, or both.

Adjusting the Display

To adjust the display, be sure that power is not supplied to the TDC5. Remove the top cover panel of the TDC5 and adjust P1 on the Processor and Memory board for best display. Refer to Figure C-1 for location. Replace the cover before operating the TDC5.

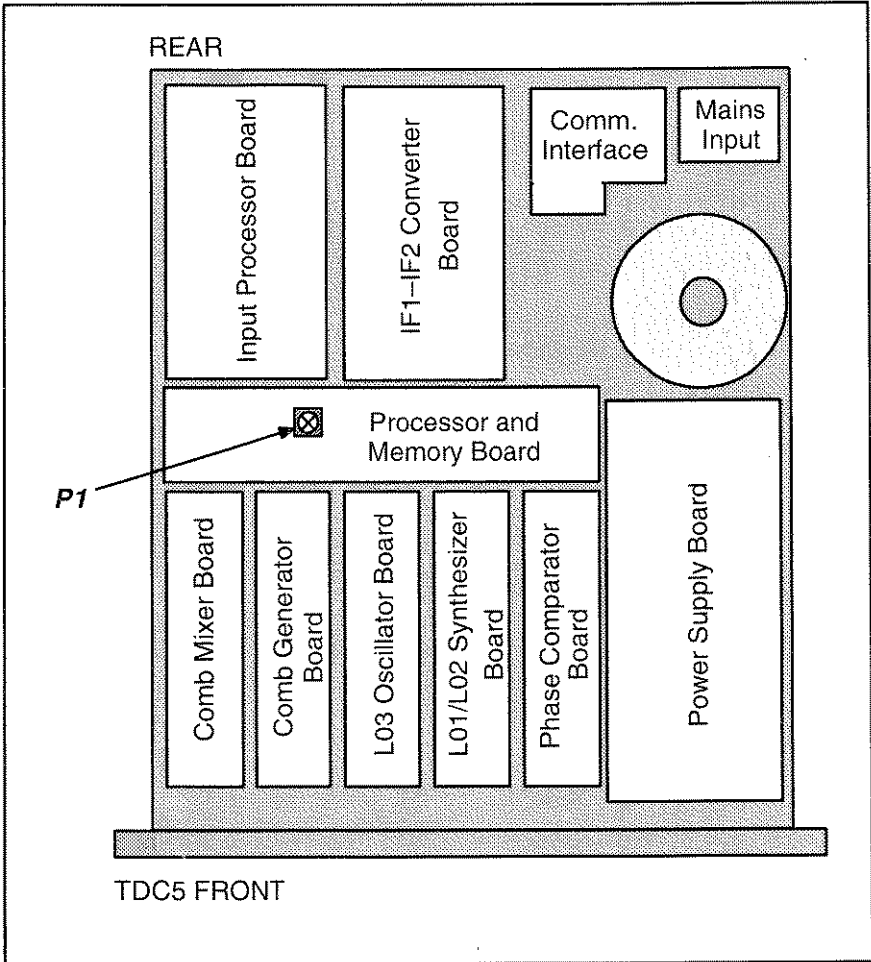

Figure C-1: Circuit Board Layout, Showing Location of P1

Changing the Mains Voltage Setting

Check to see if the TDC5 mains voltage setting matches your power source voltage, as described on page 1–4. If it does not match, change the mains voltage setting as follows:

1. Disconnect the power cable from the TDC5.
2. Pull the voltage selector straight out of the rear panel, rotate it by 180°, then plug it back in. The fuses are automatically placed in the correct position for operation.
3. Referring to Figure 1–1, verify that the new voltage setting matches your AC supply voltage.
4. Reconnect the TDC5 to the AC power source.

Fuse Replacement

1. Disconnect the power cable from the TDC5 rear panel.
2. Remove the voltage selector from the power input connector by pulling straight out. The fuse corresponding to the selected source voltage is on top of the fuse holder.
3. Pull the old fuse up and out, and replace it with a new fuse of the same type. Use only 250 V, 1 A fuses.
4. Check the arrows on the fuse holder to be sure you have placed the fuse in the correct location (110-120 V or 220-240 V).

Cleaning the TDC5

The instrument should be cleaned often enough to prevent dust and dirt from accumulating. Dirt acts as a thermal insulator, preventing effective heat dissipation, and can also provide high-resistance electrical leakage paths between conductors or components in a humid environment.



CAUTION. Do not allow water to get inside any enclosed assembly or component. Do not clean any plastic materials with benzene, toluene, xylene, acetone, or similar compounds, because they may damage the plastic.

Exterior Cleaning

Clean the dust from the outside of the instrument with a soft, clean cloth or small brush. A brush is especially useful for removing dust from around the buttons and connectors. Hardened dirt can be removed using a soft cloth dampened with a mild detergent and water solution. Abrasive cleaners should not be used.

Interior Cleaning

Interior cleaning and maintenance should be performed by qualified service personnel only. Do not clean rosin residue.



CAUTION. A 2% RMA flux content solder is recommended for making repairs in this instrument. Cleaning of rosin residue is not recommended. Most cleaning solvents tend to reactivate the rosin and spread it under components where it may cause corrosion under humid conditions. The rosin residue, if left alone, does not exhibit these corrosive properties.

Appendix D: Channel Tables

This section contains Cable Television Standard, HRC, and Broadcast channel tables. These tables are used by the TDC5 when specified by the tuning menu command.

Table D-1: CATV Standard Channel Table

Channel	Frequency	Channel	Frequency	Channel	Frequency
2	55.25 MHz	32	271.25 MHz	62	451.25 MHz
3	61.25 MHz	33	277.25 MHz	63	457.25 MHz
4	67.25 MHz	34	283.25 MHz	64	463.25 MHz
5	77.25 MHz	35	289.25 MHz	65	469.25 MHz
6	83.25 MHz	36	295.25 MHz	66	475.25 MHz
7	175.25 MHz	37	301.25 MHz	67	481.25 MHz
8	181.25 MHz	38	307.25 MHz	68	487.25 MHz
9	187.25 MHz	39	313.25 MHz	69	493.25 MHz
10	193.25 MHz	40	319.25 MHz	70	499.25 MHz
11	199.25 MHz	41	325.25 MHz	71	505.25 MHz
12	205.25 MHz	42	331.25 MHz	72	511.25 MHz
13	211.25 MHz	43	337.25 MHz	73	517.25 MHz
14	121.25 MHz	44	343.25 MHz	74	523.25 MHz
15	127.25 MHz	45	349.25 MHz	75	529.25 MHz
16	133.25 MHz	46	355.25 MHz	76	535.25 MHz
17	139.25 MHz	47	361.25 MHz	77	541.25 MHz
18	145.25 MHz	48	367.25 MHz	78	547.25 MHz
19	151.25 MHz	49	373.25 MHz	79	553.25 MHz
20	157.25 MHz	50	379.25 MHz	80	559.25 MHz
21	163.25 MHz	51	385.25 MHz	81	565.25 MHz
22	169.25 MHz	52	391.25 MHz	82	571.25 MHz
23	217.25 MHz	53	397.25 MHz	83	577.25 MHz
24	223.25 MHz	54	403.25 MHz	84	583.25 MHz
25	229.25 MHz	55	409.25 MHz	85	589.25 MHz
26	235.25 MHz	56	415.25 MHz	86	595.25 MHz
27	241.25 MHz	57	421.25 MHz	87	601.25 MHz
28	247.25 MHz	58	427.25 MHz	88	607.25 MHz
29	253.25 MHz	59	433.25 MHz	89	613.25 MHz
30	259.25 MHz	60	439.25 MHz	90	619.25 MHz
31	265.25 MHz	61	445.25 MHz	91	625.25 MHz

Table D-1: CATV Standard Channel Table (Con't)

Channel	Frequency	Channel	Frequency	Channel	Frequency
92	631.25 MHz	107	691.25 MHz	122	781.25 MHz
93	637.25 MHz	108	697.25 MHz	123	787.25 MHz
94	643.25 MHz	109	703.25 MHz	124	793.25 MHz
95	91.25 MHz	110	709.25 MHz	125	799.25 MHz
96	97.25 MHz	111	715.25 MHz	126	805.25 MHz
97	103.25 MHz	112	721.25 MHz	127	811.25 MHz
98	109.25 MHz	113	727.25 MHz	128	817.25 MHz
99	115.25 MHz	114	733.25 MHz	129	823.25 MHz
100	649.25 MHz	115	739.25 MHz	130	829.25 MHz
101	655.25 MHz	116	745.25 MHz	131	835.25 MHz
102	661.25 MHz	117	751.25 MHz	132	841.25 MHz
103	667.25 MHz	118	757.25 MHz	133	847.25 MHz
104	673.25 MHz	119	763.25 MHz	134	853.25 MHz
105	679.25 MHz	120	769.25 MHz	135	859.25 MHz
106	685.25 MHz	121	775.25 MHz		

Table D-2: HRC Channel Table

Channel	Frequency	Channel	Frequency	Channel	Frequency
1	72.00 MHz	34	282.00 MHz	67	480.00 MHz
2	54.00 MHz	35	288.00 MHz	68	486.00 MHz
3	60.00 MHz	36	294.00 MHz	69	492.00 MHz
4	66.00 MHz	37	300.00 MHz	70	498.00 MHz
5	78.00 MHz	38	306.00 MHz	71	504.00 MHz
6	84.00 MHz	39	312.00 MHz	72	510.00 MHz
7	174.00 MHz	40	318.00 MHz	73	516.00 MHz
8	180.00 MHz	41	324.00 MHz	74	522.00 MHz
9	186.00 MHz	42	330.00 MHz	75	528.00 MHz
10	192.00 MHz	43	336.00 MHz	76	534.00 MHz
11	198.00 MHz	44	342.00 MHz	77	540.00 MHz
12	204.00 MHz	45	348.00 MHz	78	546.00 MHz
13	210.00 MHz	46	354.00 MHz	79	552.00 MHz
14	120.00 MHz	47	360.00 MHz	80	558.00 MHz
15	126.00 MHz	48	366.00 MHz	81	564.00 MHz
16	132.00 MHz	49	372.00 MHz	82	570.00 MHz
17	138.00 MHz	50	378.00 MHz	83	576.00 MHz
18	144.00 MHz	51	384.00 MHz	84	582.00 MHz
19	150.00 MHz	52	390.00 MHz	85	588.00 MHz
20	156.00 MHz	53	396.00 MHz	86	594.00 MHz
21	162.00 MHz	54	402.00 MHz	87	600.00 MHz
22	168.00 MHz	55	408.00 MHz	88	606.00 MHz
23	216.00 MHz	56	414.00 MHz	89	612.00 MHz
24	222.00 MHz	57	420.00 MHz	90	618.00 MHz
25	228.00 MHz	58	426.00 MHz	91	624.00 MHz
26	234.00 MHz	59	432.00 MHz	92	630.00 MHz
27	240.00 MHz	60	438.00 MHz	93	636.00 MHz
28	246.00 MHz	61	444.00 MHz	94	642.00 MHz
29	252.00 MHz	62	450.00 MHz	95	90.00 MHz
30	258.00 MHz	63	456.00 MHz	96	96.00 MHz
31	264.00 MHz	64	462.00 MHz	97	102.00 MHz
32	270.00 MHz	65	468.00 MHz	98	108.00 MHz
33	276.00 MHz	66	474.00 MHz	99	114.00 MHz

Table D-3: Broadcast Channel Table

Channel	Frequency	Channel	Frequency	Channel	Frequency
2	55.25 MHz	29	561.25 MHz	55	717.25 MHz
3	61.25 MHz	30	567.25 MHz	56	723.25 MHz
4	67.25 MHz	31	573.25 MHz	57	729.25 MHz
5	77.25 MHz	32	579.25 MHz	58	735.25 MHz
6	83.25 MHz	33	585.25 MHz	59	741.25 MHz
7	175.25 MHz	34	591.25 MHz	60	747.25 MHz
8	181.25 MHz	35	597.25 MHz	61	753.25 MHz
9	187.25 MHz	36	603.25 MHz	62	759.25 MHz
10	193.25 MHz	37	609.25 MHz	63	765.25 MHz
11	199.25 MHz	38	615.25 MHz	64	771.25 MHz
12	205.25 MHz	39	621.25 MHz	65	777.25 MHz
13	211.25 MHz	40	627.25 MHz	66	783.25 MHz
14	471.25 MHz	41	633.25 MHz	67	789.25 MHz
15	477.25 MHz	42	639.25 MHz	68	795.25 MHz
16	483.25 MHz	43	645.25 MHz	69	801.25 MHz
17	489.25 MHz	44	651.25 MHz	70	807.25 MHz
18	495.25 MHz	45	657.25 MHz	71	813.25 MHz
19	501.25 MHz	46	663.25 MHz	72	819.25 MHz
20	507.25 MHz	47	669.25 MHz	73	825.25 MHz
21	513.25 MHz	48	675.25 MHz	74	831.25 MHz
22	519.25 MHz	49	681.25 MHz	75	837.25 MHz
23	525.25 MHz	50	687.25 MHz	76	843.25 MHz
24	531.25 MHz	51	693.25 MHz	77	849.25 MHz
25	537.25 MHz	52	699.25 MHz	78	855.25 MHz
26	543.25 MHz	53	705.25 MHz		
27	549.25 MHz	54	711.25 MHz		
28	555.25 MHz				

Appendix E: Remote Commands

This appendix section is organized as follows:

- A list of commands and their page numbers.
- A sample command description, which explains the fields that will appear in the following descriptions.
- Definitions of terms used in the command description.
- The actual command descriptions, organized in functional order.

Refer to Appendix F for instructions on programming the remote control interface, including detailed examples.

List of Commands

Command	Suffix	Description	Page
AGC_C	=	<i>Turns the AGC (automatic gain control) on or off.</i>	E-14
	?	<i>Requests the current state of the AGC.</i>	
CHANNEL	=	<i>Selects the current TDC5 channel.</i>	E-18
	?	<i>Requests the current TDC5 channel.</i>	
DELAY	=	<i>Sets AGC (automatic gain control) delay value.</i>	E-17
	?	<i>Requests the current AGC delay value.</i>	
DISC	=	<i>Puts the TDC5 in the local state.</i>	E-6
FREQ	=	<i>Sets the frequency of the TDC5.</i>	E-13
	?	<i>Requests the current frequency setting of the TDC5.</i>	
IDN	=	<i>Sets unit location.</i>	E-9
	?	<i>Requests TDC5 device name and version number.</i>	
IF_ATT	=	<i>Sets the IF attenuation value.</i>	E-16
	?	<i>Requests the current IF attenuation value.</i>	
INP	=	<i>Sets the TDC5 input (1-4).</i>	E-12
	?	<i>Requests the current input setting (1-4).</i>	

Command	Suffix	Description	Page
LOG	?	Requests the remote state of the TDC5.	E-10
MSG	=	Changes status of the TDC5.	E-7
	?	Requests the current status of the TDC5.	
MSG_C	=	Enables or disables the TDC5 message function.	E-25
	?	Requests the current status of the message enable.	
OPTMEM	=	Writes data in the 256 bytes of user space.	E-29
	?	Reads data in the 256 bytes of user space.	
PATH	=	Acknowledges receipt of a message.	E-11
	?	Polls the TDC5 to see if it has a message.	
PRESET	=	Sets the TDC5 PRESET data.	E-23
	?	Requests the current PRESET data.	
PWD	=	Puts the TDC5 in the remote state.	E-6
RECPRT	=	Selects the active PRESET (1-200).	E-22
	?	Requests the number of the active PRESET (1-200).	
REPORT	?	Requests the current TDC5 operating state.	E-28
RF_ATT	=	Sets the total RF attenuation value.	E-15
	?	Requests the current total RF attenuation value.	
SETT	=	Sets several parameters of the TDC5.	E-19
	?	Requests several parameters of the TDC5.	
STAT	=	Clears the I ² C error messages.	E-26
	?	Requests the I ² C error messages.	
TUNING	=	Sets the TUNING mode.	E-21
	?	Requests the current TUNING mode.	

Explanation of Remote Command Descriptions

COMMAND The name of the command.

Description: Short description of the command, followed by more information, if needed.

COMMAND= (Send command; only transmit cycle is needed.)

Condition: When the command can be used.

Trans data: The transmitted data that follows **COMMAND=**
It is described in four columns:

<u>Offset</u>	<u>Format</u>	<u>Name</u>	<u>Contents</u>
1	BYTE	message	bitmap

Notes: Special actions performed by the command.

COMMAND? (Query command; receive cycle follows transmit cycle.)

Condition: When the command can be used.

Trans data: The transmitted data that follows **COMMAND?**
It is described in four columns:

<u>Offset</u>	<u>Format</u>	<u>Name</u>	<u>Contents</u>
1	BYTE	message	bitmap

Notes: Special actions performed by the command.

Rec data: The received data is described in four columns:

<u>Offset</u>	<u>Format</u>	<u>Name</u>	<u>Contents</u>
1	CHAR(10)	device	'TDC5'
11	CHAR(6)	version	'V01.02'

Data:

device: A description of the first Name entry

version: A description of the second Name entry.

Terms Used in Remote Command Descriptions

BYTE

A byte has 8 bits (b7 b6 b5 b4 b3 b2 b1 b0)

Example: [65] is the representation of the byte with value 65.
[041h] is the same byte in hexadecimal notation.

CHAR

A character is stored as a normal byte.

Example: ['A'] is the representation of the character A with ASCII code 65.

CONDITION

The condition determines when a command can be used. There is a *condition flag* used by the TDC5. This flag must be true if it is used as a condition. If a NOT flag is used, then the flag must be false.

Example: After the command 'PWD=' is sent, the TDC5 is in remote state and the remote flag = TRUE, indicating a remote connection between the PC and the TDC5.

CONTENTS

Contents gives the possible values of the named variable.

0 or 1: The contents must be 0 or 1 (FALSE or TRUE).

0..255: The contents can be 0 to 255.

['ABCD']: The contents can be the given character string.

Bitmap: The bitmap is described in the data description.

FORMAT

Format refers to the format of the transmitted or received data. It can be: BYTE, WORD, Bitmap, ARRAY, or CHAR(x).

Example: CHAR(10) can be up to 10 characters, which can be represented as ['ABCDEFGHIJ']

LOCAL STATE

The TDC5 is in local state if the device can be manually controlled by the front panel. The `remote_flag = false`.

NAME

Each variable that can be sent or received has a name. The named variables are described in the Data description.

OFFSET

The offset is the relative position of the data item in the transmitted or received data. The offset starts from 1, so the first byte has `OFFSET=1`.

RECEIVED DATA (Rec data)

The received data is the data received after a receive cycle.

REMOTE STATE

The TDC5 is in remote state if the message 'REMOTE CONTROLLED' is displayed. The keyboard is disabled, so the TDC5 can only be controlled by the connected PC. The `remote_flag = true`.

TRANSMITTED DATA (Trans Data)

Transmitted data appears directly after the '=' or '?' of a command in a send cycle.

WORD

A word has 16 bits and is transmitted or received as 2 bytes. The MSB (Most Significant Byte) is followed by the LSB (Least Significant Byte).

Remote Command Descriptions

PWD

Description:

Puts the TDC5 in the remote state.

PWD=

Condition: This command is always possible.

Notes: Sets remote_flag and puts TDC5 in the remote state.

PWD?

Condition: Not a valid command.

DISC

Description:

Puts the TDC5 in the local state.

DISC=

Condition: This command is always possible.

Notes: Clears remote_flag and puts TDC5 in the local state.

DISC?

Condition: Not a valid command.

MSG

Description:

Clears or requests the status of the TDC5.

The MSG command retrieves any message the TDC5 has ready to send. The TDC5 can be polled continuously; see page F-5. For a more detailed status report of the TDC5, see the STAT? command.

MSG=

Condition: remote_flag

Trans data: 1 BYTE message bitmap

Notes: Clears the message bit(s) by the TRUE bits in the message byte.

MSG?

Condition: This command is always possible.

Rec data: 1 BYTE message bitmap

Data:

message:	(A TRUE state indicates:)
b7: Invalid remote command.	TDC5 has received an invalid command.
b6: Wrong remote parameter.	TDC5 has received the wrong parameter.
b5: Test message.	TDC5 has sent a test message.
b4: Not used.	
b3: EEPROM table empty.	EEPROM table is empty.
b2: Lock state.	TDC5 is out of lock.
b1: Error on bus II.	A communication error has occurred on the internal I ² C bus II. See the STAT? command for details.
b0: Error on bus I.	A communication error has occurred on the internal I ² C bus I. See the STAT? command for details.

Example:

Command: ['MSG?']

Condition: This command is always possible.

Result: The following data is received in the receive cycle after sending the MSG command:

[36]=[24h]= 00100100b

This means that the TDC5 has a test message and is out of lock.

IDN

Description:

Requests the TDC5 identification.

An identification is made of the device name ('TDC5'), followed by the version number (ex.: 'V01.02'). A supplemental identification is given by the *unit_location* which can be programmed by the user.

IDN=

Condition: remote_flag

Trans data: unit_location (20 characters)

IDN?

Condition: This command is always possible.

Rec data:	1	CHAR(10)	device	'TDC5'
	11	CHAR(6)	version	'V01.02'
	17	CHAR(20)	unit_loc	

Data description:

device: 10 characters which define the device.

version: 6 characters which define the version number.

unit_loc: 20 characters which can be programmed by the user.

Example:

Command: ['IDN?']

Condition: This command is always possible.

Result: The following data could be received in the receive cycle after sending the command:
['TDC5 V01.02'] ['01234567890123456789']

LOG

Description:

Requests the remote state of the TDC5.

LOG=

Condition: Not a valid command.

LOG?

Condition: This command is always possible.

Rec data: 1 BYTE log_state 0 or 1

Data description:

log_state: 0: local
1: remote

Example:

Command: ['LOG?']

Condition: This command is always possible.

Result: If [0] is the return value, the TDC5 is not in remote state.

PATH

Description:

PATH polls the TDC5 to see if there is a message.

If there is a message, the status of the TDC5 can be obtained by the MSG? command. If the messages are disabled with the MSG_C command, the TDC5 will not have a message.

PATH=

Condition: This command is always possible.

Notes: Acknowledges the message.

PATH?

Condition: This command is always possible.

Rec data: If the TDC5 has a message, it will send the path:

1	BYTE	device_address	Ad
2	BYTE	remote_address	Ars

Data description:

device_address: Ad is always 0B hex for the TDC5.

remote_address: Ars is calculated on page 0–2.

Example:

Command: ['PATH?']

Condition: This command is always possible.

Result: If the data [Ad][Ars] is returned, it means the TDC5 has a message. If there is no message, no data will be included in the reply string. (See page F–5 for a more detailed example.)

INP

Description:

Sets or requests the input of the TDC5.

INP=

Condition: remote_flag

Trans data: 1 BYTE input 1, 2, 3, or 4

INP?

Condition: remote_flag

Rec data: 1 BYTE input 1, 2, 3, or 4

Data description:

Input: The selected input of the TDC5.

Example:

Command: ['INP='] [4]

Condition: remote_flag = TRUE

Result: The input of the TDC5 will be set to 4.

FREQ

Description:

Sets or requests the frequency of the TDC5.

FREQ=

Condition: remote_flag

Trans data: 1 WORD freqH_val 45.860

3 WORD freqL_val 0.999

Notes: Automatically sets tuning mode to FREQ TUNE.

FREQ?

Condition: remote_flag

Rec data: 1 WORD freqH_val 45.860

3 WORD freqL_val 0.999

Data description:

freqH_val: The integer part of the frequency in MHz.

freqL_val: The fractional part of the frequency in 1/1000 MHz.

Example:

Command: ['FREQ='] [1 100 0 250]

Condition: remote_flag = TRUE

Result: freqH: [1 100]= 1x256+100= 356 MHz

freqL: [0 250]= 250 KHz

The total frequency in this example is 356.250 MHz.

AGC_C

Description: Sets or requests the state of the AGC (automatic gain control).

AGC_C=

Condition: remote_flag

Trans data: 1 BYTE agc_state 0 or 1

Notes: If the AGC is toggled from off to on, there will be no Delay. (See DELAY command.)

AGC_C?

Condition: remote_flag

Rec data: 1 BYTE agc_state 0 or 1

Data description:

agc_state: 0: OFF
1: ON

Example:

Command: ['AGC_C='] [1]

Condition: Remote_flag = TRUE

Result: The AGC is on.

RF_ATT

Description:

Sets or requests the total RF attenuation value.

RF_ATT=

Condition: remote_flag

Trans data: 1 BYTE rf_att_val 0..45 dB

Notes: If AGC=ON, the TDC5 restarts the gain regulation from rf_att_val.

RF_ATT?

Condition: remote_flag

Notes: If AGC=ON, the query command returns the momentary input attenuator value.

Rec data: 1 BYTE rf_att_val 0..45 dB

Data description:

Rf_att_val: Total RF attenuation value.

Example:

Command: ['RF_ATT='] [24]

Condition: remote_flag = TRUE

Result: The RF attenuation will be set to 24 dB.

IF_ATT

Description:

Sets or requests the IF attenuation value.

IF_ATT=

Condition: remote_flag

Trans data: 1 BYTE if_att_val 0..15 dB

Notes: If AGC=ON, the TDC5 restarts the gain regulation from *if_att_val*.

IF_ATT?

Condition: remote_flag

Notes: If AGC=ON, the query command returns the momentary output attenuator value.

Rec data: 1 BYTE if_att_val 0..15 dB

Data description:

If_att_val: IF attenuation value

Example:

Command: ['IF_ATT='] [9]

Condition: remote_flag = TRUE

Result: The output attenuation will be set to 9 dB.

DELAY

Description:

Sets or requests the AGC delay value.

This delay occurs only on the input to the RF attenuators. If the AGC is toggled from off to on, there will be no delay.

DELAY=

Condition: remote_flag

Trans data: 1 BYTE delay_val 0..120 sec

DELAY?

Condition: remote_flag

Rec data: 1 BYTE delay_val 0..120 sec

Data description:

delay_val: The delay value in seconds.

Example:

Command: ['DELAY='] [0]

Condition: remote_flag = TRUE

Result: No delay is introduced.

CHANNEL

Description:

Sets or requests the selected channel of the TDC5.

CHANNEL=

Condition: remote_flag

Trans data: 1 BYTE table 0, 1, or 2
2 BYTE channel

Notes: Automatically sets tuning mode to CHANNEL.

CHANNEL?

Conditions: remote_flag and TUNING = 0, 1, or 2

Rec data: 1 BYTE table 0, 1, or 2
2 BYTE channel

Data description:

table: 0: CATV STD
1: HRC
2: BDCST

channel: Selected channel number.

Example:

Command: ['CHANNEL='][1][34]

Condition: remote_flag = TRUE

Result: The TDC5 outputs channel 34 of the HRC table.

SETT

Description:

Sets or requests several parameters of the TDC5.

SETT=

Conditions: remote_flag.

Trans data:	1	BYTE	input	1, 2, 3, or 4
	2	WORD	freqH_val	45..860
	4	WORD	freqL_val	0..999
	6	BYTE	agc_state	0 or 1
	7	BYTE	rf_att_val	0..45 dB
	8	BYTE	if_att_val	0..15 dB
	9	BYTE	delay_val	0..120 sec
	10	CHAR(10)	name	

Special action: The new settings are effective immediately.

SETT?

Conditions: remote_flag.

Rec data:	1	BYTE	input	1, 2, 3, or 4
	2	WORD	freqH_val	45..860
	4	WORD	freqL_val	0..999
	6	BYTE	agc_state	0 or 1
	7	BYTE	rf_att_val	0..45 dB
	8	BYTE	if_att_val	0..15 dB
	9	BYTE	delay_val	0..120 sec
	10	CHAR(10)	name	

Data description:

Refer to the INP, FREQ, AGC_C, RF_ATT, IF_ATT, and DELAY command descriptions.

Example:

Command: ['SETT?']

Condition: remote_flag = TRUE

Result: This command returns the current setting of the TDC5:
[1][0][45][1][244][0][10][9][0][32][32][32][32][32][32][32][32][32][32][32][32]

Input = 1

Frequency = 45.5 MHz

AGC = off

RF attenuator = 10 dB

IF attenuator = 9 dB

No delay is present.

Name is filled in with space characters (see ASCII code).

TUNING

Description:

Sets or requests the tuning mode.

TUNING=

Condition: remote_flag.

Trans data: 1 BYTE mode 0, 1, 2, 3, or 4

Notes: Can change the current TDC5 tuning mode.

TUNING?

Condition: remote_flag.

Rec data: 1 BYTE mode 0, 1, 2, 3, or 4

Data description:

mode: 0: CATV STD
 1: HRC
 2: BRDCST
 3: FREQ TUNE
 4: PRESET

Example:

Command: ['TUNING?']

Condition: remote_flag = TRUE

Result: Returned data of [4] means TDC5 is in preset mode.

RECPRT

Description:

Selects or requests the current preset.

RECPRT=

Condition: remote_flag.

Trans data: 1 BYTE pres_nr 1..200

Notes: The data in pres_nr becomes the current setting of the TDC5. Automatically sets the tuning mode to PRESET.

RECPRT?

Condition: remote_flag and TUNING = 4

Rec data: 1 BYTE pres_nr 1..200

Data description:

pres_nr: Number of the recalled preset.

Example:

Command: ['RECPRT?']

Condition: remote_flag = TRUE and TUNING = 4

Result: Returns the value of the current preset.

PRESET

Description:

Sets or requests the stored preset data of the TDC5, without affecting the present operation of the TDC5.

PRESET=

Conditions: remote_flag.

Trans data:	1	BYTE	pres_nr	1..200
	2	BYTE	input	1, 2, 3, 4
	3	WORD	freqH_val	45..860
	5	WORD	freqL_val	0..999
	7	BYTE	agc_state	0 or 1
	8	BYTE	rf_att_val	0..45 dB
	9	BYTE	if_att_val	0..15 dB
	10	BYTE	delay_val	0..120 sec
	11	CHAR(10)	name	

PRESET?

Conditions: remote_flag.

Trans data:	1	BYTE	pres_nr	1..200
Rec data:	1	BYTE	input	1, 2, 3, 4
	2	WORD	freqH_val	45..860
	4	WORD	freqL_val	0..999
	6	BYTE	agc_state	0 or 1
	7	BYTE	rf_att_val	0..45 dB
	8	BYTE	if_att_val	0..15 dB
	9	BYTE	delay_val	0..120 sec
	10	CHAR(10)	name	

Data description:

pres_nr: Number of the recalled preset. See INP, FREQ, AGC_C, RF_ATT, IF_ATT, and DELAY commands.

Example:

Command: ['PRESET?'] [105]

Conditions: remote_flag= TRUE

Result: This command returns the preset data from Preset 105.

MSG_C

Description:

Sets or requests the status of the TDC5 message enable.

When MSG_C is toggled from 1 to 0, all pending messages are cleared.

MSG_C=

Condition: remote_flag.

Trans data: 1 BYTE msg_state 0 or 1

MSG_C?

Condition: remote_flag.

Rec data: 1 BYTE msg_state 0 or 1

Data description:

msg_state: 0: disabled
1: enabled

Example:

Command: ['MSG_C='] [1]

Condition: remote_flag = TRUE

Result: The TDC5 is now able to generate messages.

STAT

Description:

Clears or requests the I²C error messages.

STAT=

Condition: remote_flag.

Trans data:	1	BYTE	error_mapH	bitmap
	2	BYTE	error_mapL	bitmap

Notes: Acknowledges the message by clearing the TRUE bit(s) defined in the 2 bytes.

STAT?

Condition: remote_flag.

Rec data:	1	BYTE	error_mapH	bitmap
	2	BYTE	error_mapL	bitmap

Data description:

Bit is TRUE when an I²C component is not functional.

error_mapH:

b7:	x
b6:	x
b5:	x
b4:	x
b3:	x
b2:	EEPROM
b1:	EEPROM
b0:	EEPROM

error_mapL:

- b7: FC, Det2
- b6: Det1
- b5: RF filter bank I
- b4: IF_ATT
- b3: RF_ATT, Input selector
- b2: RF filter bank II, RF_att (5 dB)
- b1: Comb
- b0: LO3

Example:

Command: ['STAT?']

Condition: remote_flag = TRUE

Result: This command returns the status of every I²C.

[1][18] = [0000 0001b][0001 0010]

In this example, one EEPROM, the comb selector, and the IF attenuator I²C are not functional.

REPORT

Description:

Requests the current TDC5 operating state.

REPORT=

Condition: Not a valid command.

REPORT?

Condition: remote_flag.

Rec data: 1 BYTE Tic_state 0, 1, 2, 3, or 4

Data description:

Tic_state: 0: OK
1: RANGING
2: NO SIGNAL
3: OVERLOAD
4: INTERNAL ERROR
AGC OFF: Tic_state always = 0

Example:

Command: ['REPORT?']

Condition: remote_flag = TRUE

Result: Returned data of [1] means the TDC5 is ranging.

OPTMEM

Description:

Write or read data in the 256 bytes of user space.

OPTMEM=

Conditions: remote_flag.

Trans data:	1	BYTE	offset	0..255
	2	ARRAY[0..(256–offset)]	data	0..255

OPTMEM?

Conditions: remote_flag.

Trans data:	1	BYTE	offset	0..255
	2	BYTE	length	0..(256–offset)
Rec data:	1	ARRAY[0..(256–offset)]	data	0..255

Data description:

offset: Offset location of the first bit of transmitted or received data with respect to the 256 bytes of memory.

length: An array can be as short as 0 bytes; it can be as long as 256 bytes minus the offset.

data: Accepts any value from 0 to 255.

Example:

Conditions: remote_flag = TRUE

Command: ['OPTMEM='][10]['T']['E']['S']['T']

Result: This command writes the word 'TEST' in the user memory on offset 10.

Appendix F: Remote Communication

This appendix section tells how to program the remote control communications. Remote commands are described in Appendix E.

Protocol

The TDC5 uses the BCP Simplified Communication Link Protocol (SCL), which has the following parameters:

Speed: 1200, 2400, 4800, 9600, or 19200 bps (as set by the TDC5).

Character format: 1 start bit / 8 data bits / 1 stop bit

Hardware: RS485 or RS232 (depending on the TDC5 settings).

Handshaking: If RS232, RTS/CTS hardware handshaking is used, the TDC5 activates RTS and waits for transmission until CTS is active (for a maximum period of 5 seconds).

With SCL Protocol, data can be sent and received using the standard I/O functions found in most programming languages, such as C, PASCAL, and BASIC. The SCL Protocol is an asynchronous binary protocol; not text or ASCII-based. Communication is based on bytes ranging from 0 to 255. Special bytes are listed in Table F-1.

Table F-1: Special Bytes

Character	ASCII	Description	Control Characters
STX	02 hex	Start of data	^B
ETX	03 hex	End of data	^C
ENQ	05 hex	Enquiry	^E
DLE	10 hex	Data Link Escape	^P
ACK0	11 hex	Device is ready	^Q
WACK	3B hex	Device is not ready	;
Ad	0B hex	Device address	^K
Ar	*	User-defined remote address	*
Ars	*	Send remote address	*
Arr	*	Receive remote address	*

* Remote addresses are user-defined. Refer to the Address description.

Using Terminal Programs

The sample in Table F-2 uses the Windows Terminal program to tie selected TDC5 remote commands to PC keys F1 through F5. Other terminal programs, such as Kermit, can also be used. Batches of commands can be created, so that entire sequences can be performed by pressing one key. The following pages contain examples of remote communication that can be programmed in this manner.

Table F-2: Windows Terminal Program

PC Key	Assigned Key Name	Assigned Command
F1	Address	^P^E^KH
F2	IDN?	^P^E^KH^P^BIDN?^P^C
F3	Query	^P^E^KI
F4	Remote	^P^E^KH^P^BPWD=^P^C
F5	Local	^P^E^KH^P^BDISC=^P^C

Addresses

To address the TDC5, the PC uses a device address of 0B hex. It also uses a *send address (Ars)* when sending data, and a *receive address (Arr)* when requesting data. These addresses are formed as follows:

- Ar (remote address) is user-defined through the TDC5 PROGRAM COMM-PORT menu.
- Ars (*send* remote address) = Ar x 2.
- Arr (*receive* remote address) = Ar x 2 + 1.

Example:

If a TDC5 is given a remote address of 24 hex, its addresses will be:

- Ad: from Table F-1 = **0B hex**
- Ars: (24 hex) x 2 = **48 hex**
- Arr: (24 hex) x 2 + 1 = **49 hex**

Sending Data to the TDC5

Send Addressing Phase

The PC uses Ad and Ars to address the TDC5. This aborts all other communication on the same bus. The TDC5 answers with a *ready phase* if it is ready to receive data, or a *not ready phase* if it is not ready. Sample send communication between the PC and TDC5 follows, with descriptions in *italics*.

The PC addresses a TDC5 that is not ready to receive data:

PC > [DLE] [ENQ] [Ad] [Ars]	<i>Addressing phase</i>
TDC5 > [DLE] [WACK]	<i>Not Ready phase</i>

The PC addresses a TDC5 that is ready, and the PC sends data:

PC > [DLE] [ENQ] [Ad] [Ars]	<i>Addressing phase</i>
TDC5 > [DLE] [ACK0] [Ad] [Ars]	<i>Ready phase</i>
PC > [DLE] [STX] [Data] [DLE] [ETX]	<i>Data phase</i>

The (*not*) *ready phase* can be ignored; the PC can transmit the *addressing phase* and the *data phase* at once, even though it does not know if the TDC5 is ready to receive data. In this situation, a *not ready* transmission from the TDC5 is aborted after receiving the first byte of the *data phase*, so that the PC receives only a DLE character.

The PC addresses a TDC5 that is not ready, ignores the not ready phase, and sends data:

PC > [DLE] [ENQ] [Ad] [Ars]	<i>Addressing phase</i>
TDC5 > [DLE]	<i>Aborted Ready phase</i>
PC > [DLE] [STX] [Data] [DLE] [ETX]	<i>Data phase</i>

When sending data, Ad and Ars can be replaced by FF hex, a *wild card address*. When the TDC5 gives a ready phase, it will send its real address. This allows the PC to determine the address of a TDC5. The wild card remote address is always a *send remote address* (even though it is an odd address).

Send Data Phase

The data can be divided into two parts: Commands and Parameters.

There are two types of commands; SELECT and QUERY.

- SELECT commands end with an '=' (such as 'PRESET='). They are used to send data to the TDC5.
- QUERY commands end with a '?' (such as 'PRESET?'). They tell the TDC5 to prepare data that will be received by the PC.

Commands can be followed by parameters. Parameters are in binary format; a byte can have the value of 0 to 255. If the byte 10(hex) is part of the parameters, this byte must be transmitted twice, so that no confusion can exist with the DLE ETX at the end of the *data phase*.

Receiving Data from the TDC5

Receive Addressing Phase

The PC uses Ad and Arr to address the TDC5. This aborts all other communication on the same bus. The TDC5 answers with a *not ready phase* if it has no data, and a *ready phase* followed by a *data phase* if it has data. The receive data phase contains Ad and Arr, to be sure that the data comes from the correct TDC5. Sample receive communication between the PC and TDC5 follows, with descriptions in *italics*.

The PC addresses a TDC5 that has no data available:

PC > [DLE] [ENQ] [Ad] [Arr] *Addressing phase*

TDC5 > [DLE] [WACK] *Not Ready phase*

The PC addresses a TDC5 that has data available, and the TDC5 returns the data:

PC > [DLE] [ENQ] [Ad] [Arr] *Addressing phase*

TDC5 > [DLE] [STX] [Ad] [Arr] [Data] [DLE] [ETX] *Ready phase
and Data phase*

If the byte 10(hex) is part of the data, this byte will be received twice, so that no confusion can exist with the DLE ETX at the end of the data phase.

Polling the TDC5

If a TDC5 has a message, it does not send it to the PC, because more than one TDC5 can be connected to the same remote interface bus and there could be data contention. The PC uses polling to check for messages.

Polling is done with the PATH? command. PATH? returns an empty string if the TDC5 has no message, and returns the path if the TDC5 has a message. The path contains *Ad Ars* (see Addressess on page F-2).

Polling Communication

The following example is one continuous polling communication between the PC and the TDC5. The values for Ad, Ars, and Arr can be calculated according to instructions on page F-2.

The PC addresses a TDC5 that is busy, repeats the addressing phase until the TDC5 returns a ready phase, then the PC sends the 'PATH?' command.

PC > [DLE] [ENQ] [Ad] [Ars]	<i>Send Addressing phase</i>
TDC5 > [DLE] [WACK]	<i>Not Ready phase</i>
PC > [DLE] [ENQ] [Ad] [Ars]	<i>Send Addressing phase</i>
TDC5 > [DLE] [ACK0] [Ad] [Ars]	<i>Ready phase</i>
PC > [DLE] [STX] ['PATH?'] [DLE] [ETX]	<i>Data phase</i>

After receiving the PATH? command, the TDC5 places its answer in its transmit buffer. The PC tries to retrieve the message with a receive cycle, but the TDC5 has not processed the answer yet.

PC > [DLE] [ENQ] [Ad] [Arr]	<i>Receive Addressing phase</i>
TDC5 > [DLE] [WACK]	<i>Not ready phase</i>

The PC repeats the addressing phase. The TDC5 is ready and transmits its data phase. There is no data included, which means that the TDC5 has no message.

PC > [DLE] [ENQ] [Ad] [Arr] *Receive Addressing phase*

TDC5 > [DLE] [STX] [Ad] [Arr] [DLE] [ETX] *Data phase*

The PC continuously polls the TDC5.

PC > [DLE] [ENQ] [Ad] [Ars] *Send Addressing phase*

TDC5 > [DLE] [ACK0] [Ad] [Ars] *Ready phase*

PC > [DLE] [STX] ['PATH?'] [DLE] [ETX] *Data phase*

PC > [DLE] [ENQ] [Ad] [Arr] *Receive Addressing phase*

The TDC5 responds with data when it has a message. The [data] is the path, Ad Ars, which in the sample on page F-2 is [0Bh][48h].

TDC5 > [DLE] [STX] [Ad] [Arr] [data] [DLE] [ETX] *Data phase*

The PC responds to the data. This acknowledges the message. The PC will continue to poll, but this message will not be reported again.

PC > [DLE] [ENQ] [Ad] [Ars] *Send Addressing phase*

TDC5 > [DLE] [ACK0] [Ad] [Ars] *Ready phase*

PC > [DLE] [STX] ['PATH?'] [DLE] [ETX] *Data phase*

Getting the Message

Polling a TDC5 only tells the PC if the device has a message. To receive the message, the MSG? command is required.

MSG? Communication

The following example is one continuous MSG? communication between the PC and the TDC5.

The PC addresses a TDC5 that is busy, repeats the addressing phase until the TDC5 returns a ready phase, then the PC sends the 'MSG?' command.

```
PC > [DLE] [ENQ] [Ad] [Ars]           Send addressing phase
TDC5 > [DLE] [ACK0] [Ad] [Ars]        Ready phase
PC > [DLE] [STX] ['MSG?'] [DLE] [ETX] Data phase
```

After receiving the MSG? command, the TDC5 places its answer in its transmit buffer, and the PC retrieves the message with a receive phase. The data in this example (20h) indicates that a test message has been generated. Other bit patterns are listed with the MSG? command.

```
PC > [DLE] [ENQ] [Ad] [Arr]           Receive addressing phase
TDC5 > [DLE] [STX] [Ad] [Arr] [20h] [DLE] [ETX] Data phase
```

The PC acknowledges the data by sending the MSG= command followed by the data bit pattern. The PC will continue to poll, but this data will not be reported again.

```
PC > [DLE] [ENQ] [Ad] [Ars]           Send addressing phase
TDC5 > [DLE] [ACK0] [Ad] [Ars]        Ready phase
PC > [DLE] [STX] ['MSG='] [20h] [DLE] [ETX] Data phase
```

Index

A

- Accessories, 1–2
 - cable, BNC, 1–2
 - power cord, 1–2
 - rack mount kit, 1–2
 - replacement fuse, 1–2
 - trim adjustment tool, 1–2
- Address, 3–10
- Adjusting the display, C–2
- AGC, 2–10, 3–5
- AGC_C remote command, E–14
- Attenuation, 2–11, 3–6
- Automatic gain control, 2–10, 3–5

B

- Baud rate, 3–9
- Byte, E–4

C

- CH, 3–4
- Channel, 3–4
- CHANNEL remote command, E–18
- Channel tables, 3–4, 3–8, D–1
 - broadcast, D–4
 - CATV, D–1
 - HRC, D–3
- Char, E–4
- Condition, E–4
- Condition flag, E–4
- condition-flags, E–9
- Connectors, 2–1
- Contents, E–4
- Controls, 2–1

D

- Delay, 2–11, 3–6
- DELAY remote command, E–17
- DISC remote command, E–6
- Display adjustment, C–2
- Down key, 2–1
- DS1200, 1–1

E

- Electrical installation, 1–3
- Electrical specification, A–1
- Enter key, 2–1

F

- Format, E–4
- FREQ, 3–3
- FREQ remote command, E–13
- Frequency, 3–3
- Front panel
 - controls, 2–1
 - display, 2–1
 - illustration, 2–3
- Fuse, 1–2

I

- IDN remote command, E–9
- IF
 - attenuation, 2–11, 3–7
 - output, 3–5, A–2
 - output connector, 2–2
- IF_ATT remote command, E–16
- INP, 2–10

INP remote command, E-12
Input, 2-10, 3-5
Input connectors, 2-2
Installation, 1-3
Internal error, 2-1

L

LCD display, 2-1
 adjustable, C-2
Left key, 2-1
Local state, E-5
LOG remote command, E-10

M

Mains voltage setting, 1-3
Mechanical installation, 1-5
Menu commands, 3-3-3-10
Menu key, 2-2
Menu overview, 3-1
Menu tree, 3-2
Messages, 3-9
Modem, 3-8
MSG remote command, E-7
MSG_C remote command, E-25

N

Name, E-5

O

Offset, E-5
On / Off switch, 2-2
Operating procedures, 2-5
Operating temperature, 1-5
Operator's checkout procedure, 1-9

OPTMEM remote command, E-29
Output, 3-5
Output connector, 2-2

P

Packaging, C-1
PATH remote command, E-11
PC communications, 3-8-3-10,
 B-1
Performance requirements, A-1
Physical characteristics, A-4
Polling the TDC5, F-5
Power
 cord, 1-2
 indicator, 2-1
 input connector, 2-2
 source, 1-3
 switch, 2-2
PR, 3-5
PRESET remote command, E-23
Presets, 2-12, 2-14, 3-5, 3-7, 3-8
Program comm-port, 2-16, 3-8
Program presets, 2-12, 3-8
Protocol, F-1
PWD remote command, E-6

R

Rack mount kit, 1-2
Rack mounting, 1-5
Rear panel illustration, 2-3
Recall presets, 2-14, 3-5
Received data, E-5
RECPRT remote command, E-22
Remote commands, E-1
 command descriptions, E-6
 list of commands, E-1
 terms used, E-4

Remote control, 2-16, 3-8, B-1
 addresses, F-2
 handshaking, F-1
 hardware, F-1
 MSG? communication, F-6
 polling the TDC5, F-5
 programming sequences, F-2
 protocol, F-1
 receiving data, F-4
 sample communication, F-5
 sending data, F-3
Remote state, E-5
REPORT remote command, E-28
RF
 attenuation, 2-11, 3-7
 input, 3-5, A-1
 input connectors, 2-2
RF_ATT remote command, E-15
RS232
 connector, 2-2, B-1
 enable, 3-9
RS485
 connector, 2-2, B-2
 enable, 3-9

S

Save As..., 2-12, 3-7
Send Test Message, 3-10

SETT remote command, E-19
Specifications, A-1
Standard accessories, 1-2
STAT remote command, E-26

T

TDM5, 1-1
Transmitted data, E-5
Tuning, 2-7, 3-8
 channel, 2-8, 3-4
 frequency, 2-8, 3-3
 presets, 2-14
TUNING remote command, E-21

U

Up key, 2-1

V

Voltage selector, 2-2
Voltage, mains, 1-3

W

Word, E-5



