

Instructions

Tektronix

P6137
10X Passive Probe
for 2400 Series Oscilloscopes

070-6432-03

www.tektronix.com



070643203

Copyright © Tektronix, Inc. All rights reserved.

Tektronix products are covered by U.S. and foreign patents, issued and pending. Information in this publication supercedes that in all previously published material. Specifications and price change privileges reserved.

Tektronix, Inc., P.O. Box 500, Beaverton, OR 97077

TEKTRONIX and TEK are registered trademarks of Tektronix, Inc.

WARRANTY

Tektronix warrants that the products that it manufactures and sells will be free from defects in materials and workmanship for a period of one (1) year from the date of purchase from an authorized Tektronix distributor. If any such product proves defective during this warranty period, Tektronix, at its option, either will repair the defective product without charge for parts and labor, or will provide a replacement in exchange for the defective product. Batteries are excluded from this warranty.

In order to obtain service under this warranty, Customer must notify Tektronix of the defect before the expiration of the warranty period and make suitable arrangements for the performance of service. Customer shall be responsible for packaging and shipping the defective product to the service center designated by Tektronix, shipping charges prepaid, and with a copy of customer proof of purchase. Tektronix shall pay for the return of the product to Customer if the shipment is to a location within the country in which the Tektronix service center is located. Customer shall be responsible for paying all shipping charges, duties, taxes, and any other charges for products returned to any other locations.

This warranty shall not apply to any defect, failure or damage caused by improper use or improper or inadequate maintenance and care. Tektronix shall not be obligated to furnish service under this warranty a) to repair damage resulting from attempts by personnel other than Tektronix representatives to install, repair or service the product; b) to repair damage resulting from improper use or connection to incompatible equipment; c) to repair any damage or malfunction caused by the use of non-Tektronix supplies; or d) to service a product that has been modified or integrated with other products when the effect of such modification or integration increases the time or difficulty of servicing the product.

THIS WARRANTY IS GIVEN BY TEKTRONIX WITH RESPECT TO THE LISTED PRODUCTS IN LIEU OF ANY OTHER WARRANTIES, EXPRESS OR IMPLIED. TEKTRONIX AND ITS VENDORS DISCLAIM ANY IMPLIED WARRANTIES OF MERCHANTABILITY OR FITNESS FOR A PARTICULAR PURPOSE. TEKTRONIX' RESPONSIBILITY TO REPAIR OR REPLACE DEFECTIVE PRODUCTS IS THE SOLE AND EXCLUSIVE REMEDY PROVIDED TO THE CUSTOMER FOR BREACH OF THIS WARRANTY. TEKTRONIX AND ITS VENDORS WILL NOT BE LIABLE FOR ANY INDIRECT, SPECIAL, INCIDENTAL, OR CONSEQUENTIAL DAMAGES IRRESPECTIVE OF WHETHER TEKTRONIX OR THE VENDOR HAS ADVANCE NOTICE OF THE POSSIBILITY OF SUCH DAMAGES.

General Safety Summary

Review the following safety precautions to avoid injury and prevent damage to this product or any products connected to it. To avoid potential hazards, use this product only as specified.

Only qualified personnel should perform service procedures.

To Avoid Fire or Personal Injury

Use Proper Power Cord. Use only the power cord specified for this product and certified for the country of use.

Use Proper Voltage Setting. Before applying power, ensure that the line selector is in the proper position for the power source being used.

Connect and Disconnect Properly. Connect the probe output to the measurement instrument before connecting the probe to the circuit under test. Disconnect the probe input and the probe ground from the circuit under test before disconnecting the probe from the measurement instrument.

Ground the Product. This product is indirectly grounded through the grounding conductor of the mainframe power cord. To avoid electric shock, the grounding conductor must be connected to earth ground. Before making connections to the input or output terminals of the product, ensure that the product is properly grounded.

Observe All Terminal Ratings. To avoid fire or shock hazard, observe all ratings and markings on the product. Consult the product manual for further ratings information before making connections to the product.

Do not apply a potential to any terminal, including the common terminal, that exceeds the maximum rating of that terminal.

Do Not Operate Without Covers. Do not operate this product with covers or panels removed.

Use Proper Fuse. Use only the fuse type and rating specified for this product.

Avoid Exposed Circuitry. Do not touch exposed connections and components when power is present.

Do Not Operate With Suspected Failures. If you suspect there is damage to this product, have it inspected by qualified service personnel.

Do Not Operate in Wet/Damp Conditions.

Do Not Operate in an Explosive Atmosphere.

Keep Product Surfaces Clean and Dry.

Provide Proper Ventilation. Refer to the manual's installation instructions for details on installing the product so it has proper ventilation.

Symbols and Terms

Terms in this Manual. These terms may appear in this manual:



WARNING. *Warning statements identify conditions or practices that could result in injury or loss of life.*



CAUTION. *Caution statements identify conditions or practices that could result in damage to this product or other property.*

Symbols on the Product. The following symbols may appear on the product:



CAUTION
Refer to Manual



Service Safety Summary

Only qualified personnel should perform service procedures. Read this *Service Safety Summary* and the *General Safety Summary* before performing any service procedures.

Do Not Service Alone. Do not perform internal service or adjustments of this product unless another person capable of rendering first aid and resuscitation is present.

To avoid electric shock, do not touch exposed connections.

Operating Considerations

This manual provides the information necessary to begin making measurements with your P6137 probe. Topics are presented in the following order:

- **Operating Considerations**—Information about using the probe.
- **Specifications**—Characteristics of the probe.
- **Adjustment/Maintenance**—Instructions for cleaning the probe and replacing major assemblies.
- **Replaceable Parts**—Exploded views of the probe and replaceable parts lists.

Adverse Effects of Ground Lead Inductance

Ground Lead inductance can significantly reduce the performance of a probe. As shown in Figure 1, the ground lead inserts a series inductance into the signal path forming a series-resonant circuit between C_{in} of the probe and ground lead L , with only R_{source} as damping. This forms a resonant circuit with:

$$f_0 = 1 \div (2\pi \sqrt{LC})$$

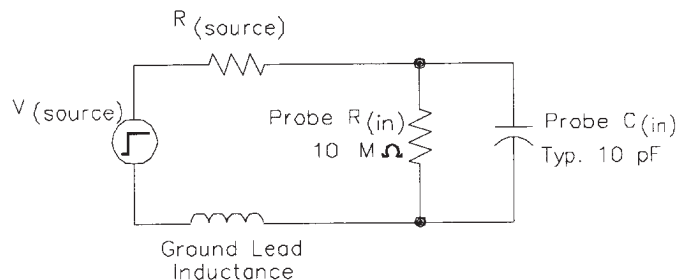

Figure 1: Schematic representation of probe

A six-inch ground lead has $\approx 180\text{ MHz}$, which is within the mid-frequency response of the instrument. This greatly degrades rise time, bandwidth, and transient accuracy (see Figure 2). For best results, make sure that the ground lead inductance is at a minimum.

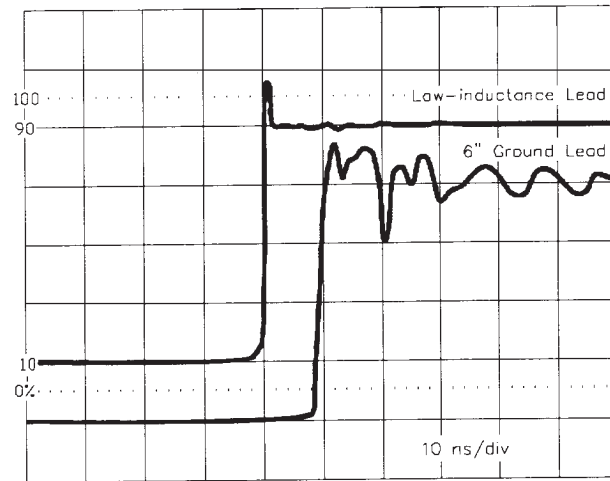

Figure 2: Typical response with a 6-inch ground lead ($T_r = 2$ ns)

The Low-Inductance Lead (shown in Figure 3) provided with all P6137 probes allows for a substantial reduction of ground-lead inductance (≈ 32 nH instead of 140 nH). Remove the ribbed plastic tip cover (1), install the ground collar (2), so that the socket is pointing toward the probe tip. Reinstall the ribbed cover. Insert the Low-Inductance Lead (3), from the accessory pack, into the ground socket.

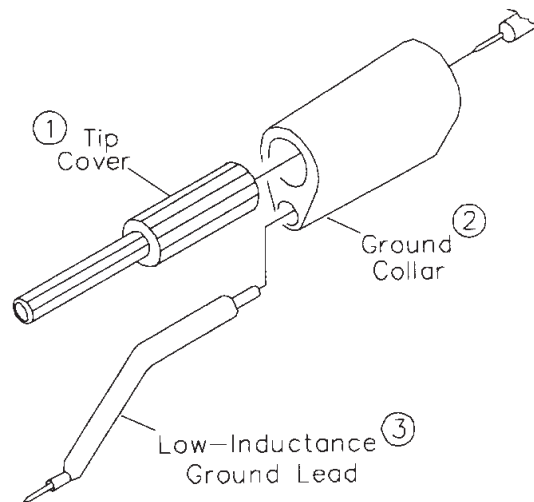

Figure 3: Low-inductance lead

Specifications

The P6137 is a compact, 1.5 meter 10X, passive voltage probe designed specifically for use with the Tektronix 2400 Series oscilloscopes. It is fully compatible with the Tektronix family of compact probe accessories.

Table 1: Electrical Characteristics (Probe installed on 2400 Series Oscilloscopes)

Characteristic	Description
Attenuation	10X \pm 1% at DC
Input Impedance (System)	10 M Ω shunted by 10.8 pF at DC (See Figure 4)
Compensation Range	12 pF to 18 pF
Signal Delay	Delay difference between any two probes of equal length is <200 ps
System Bandwidth (-3 dB, using a properly terminated 50 Ω source)	
With 2467X or 2465B oscilloscopes	>400 MHz
With 2467 or 2465A oscilloscopes	>350 MHz
With 2455X oscilloscopes	>250 MHz
With 2445X oscilloscopes	>200 MHz
Maximum Non-Destructive Input Voltage	500 V (DC + peak AC) to 1.3 MHz (See Figure 5 for voltage curve.)

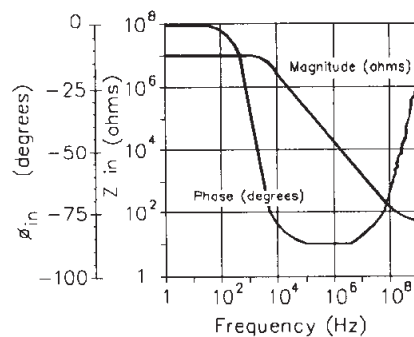

Figure 4: Typical input impedance

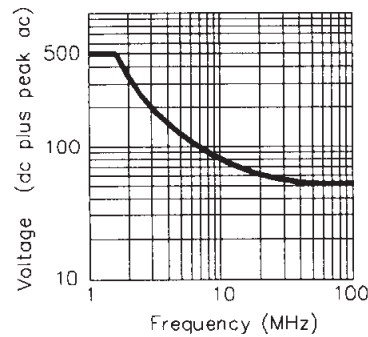

Figure 5: Typical voltage derating versus frequency

Table 2: Environmental Characteristics

Characteristics	Description
Temperature Range	
Operating	-15°C to +65°C (+5°F to +149°F)
Non-Operating	-62°C to +85°C (-80°F to +185°F)
Humidity	Five cycles (120 hr) at 95% to 97% relative humidity. Per Tek Standard 062-2847-00, Class 3. Refer to MIL-E-16400F, paragraphs 4.5.9 through 4.5.9.5.1, Class 4.

Table 3: Physical Characteristics

Characteristics	Description
Probe Cable Length	1.5 m (≈ 5 ft)
Net Weight	109 g (3.9 oz)

Safety

To avoid explosion, do not operate this product in an explosive atmosphere unless it has been specifically certified for such operation.

This product meets the requirements of UL 1244.

Probe Adjustment/Maintenance



WARNING. The following servicing instructions are for use by qualified personnel only. To avoid electrical shock, do not perform any probe maintenance while the probe is connected to a signal source.

Probe Compensation

Due to variations in oscilloscope input characteristics, probe low-frequency compensation should be checked and adjusted after moving the probe from one input to another.

To adjust low-frequency compensation, apply a 1 kHz square-wave signal (such as an oscilloscope calibrator output) to the probe tip. Using a low-reactance alignment tool, adjust the probe's compensation capacitor through the hole in the compensation box to obtain the squarest waveform at the front corner.

High-frequency compensation seldom requires adjustment; however, if the probe has excessive high-frequency aberrations or insufficient bandwidth, then adjust the high-frequency compensation.

Typical test equipment required includes a Tektronix PG506A pulse generator (rise time of ≤ 1 ns) & Tunnel Diode Pulser (Tektronix part number 067-0681-01) with pulse rise time of ≤ 125 ps. Use a 50 Ω terminated BNC-to-compact probe tip adapter (such as Tektronix part number 013-0227-00) to connect the probe to the equipment.

To adjust high-frequency compensation, first remove the plastic cover (see the parts replacement procedures). Next, adjust R1 and R3 (shown in Figure 6) for best long-term flatness. Finally, adjust R2 and C1 for best short-term flatness. Due to interaction between controls, the adjustment procedure may need to be repeated. Refer to Figure 7 for additional information about compensation procedures.

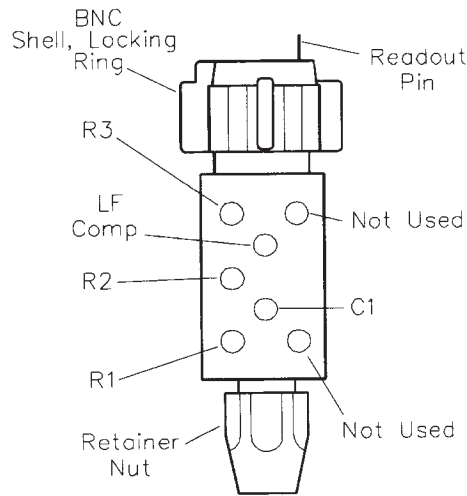

Figure 6: Location of compensation adjustments

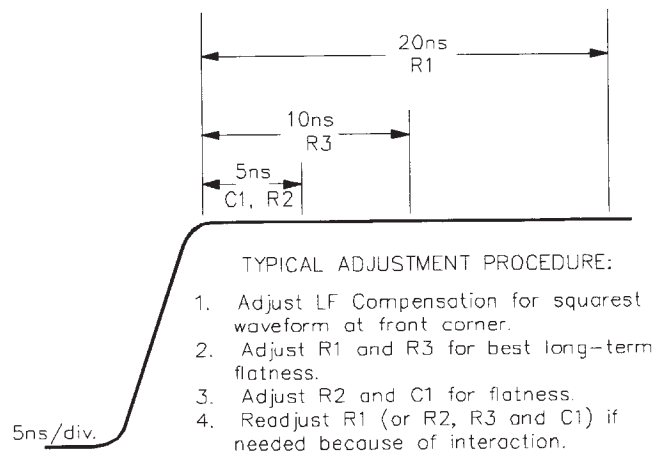

Figure 7: Effect of compensation adjustments

Cleaning

Accumulated dirt can be removed with a soft cloth dampened with a non-residue type cleaner, preferably isopropyl alcohol. Before using any other type of cleaner, consult your Tektronix Service Center or representative. In particular, avoid benzene, toluene, xylene, acetone, or similar solvents.

Parts Replacement

NOTE. Probe adjustment may be necessary after assembly replacement (refer to the adjustment procedures).

The probe tip assembly, compensation box, and cable are available as separate units through your local Tektronix field Office or representative. Individual components within the compensation box are not replaceable.

Compensation Box/Cable Disassembly and Replacement

Use the following procedure to disassemble and replace the compensation box or the cable assembly (refer to Figure 8 for parts nomenclature).

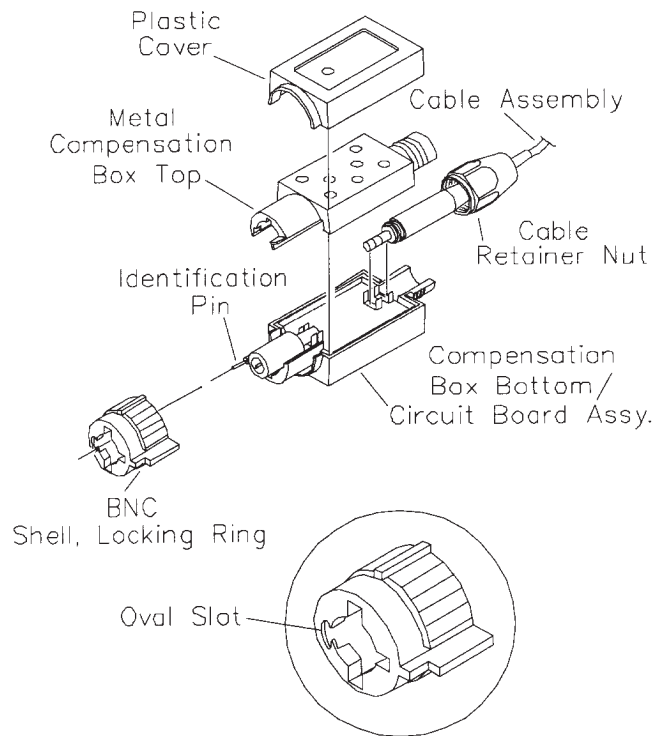

Figure 8: Compensation box assembly

1. Loosen the cable-retainer nut and pull it back onto the cable assembly.
2. Use the adjustment tool included in the accessory pack to remove the top and bottom plastic covers. Insert the adjustment tool into the side of the compensation box and pry upward and outward.
3. Pry off the BNC connector shell with a wide-blade screwdriver. Gently pry the BNC shell away from the compensation box.

NOTE. A new BNC shell comes with the replacement cable/compensation box assemblies.

4. Lift the top half of the compensation box off.
5. Remove the cable assembly.

NOTE. If you are replacing the cable assembly, you need to use the cable-retainer nut from your old cable assembly.

6. Use a new cable or a new compensation box, and snap the cable assembly into place in the bottom half of the compensation box.
7. Place the top half of the compensation box onto the lower half, slide the cable-nut up and tighten.
8. Press the new BNC shell onto the compensation box making sure the identification pin goes through the oval slot in the shell (see Figure 8).
9. Snap the plastic covers back in place.

Compact Probe Tip Assembly and Replacement

To remove the probe tip assembly, first pull the retractable hook tip off the probe (see Figure 9). Next unscrew the tip cover. Finally, unscrew the probe tip assembly. To reassemble, reverse these procedures.

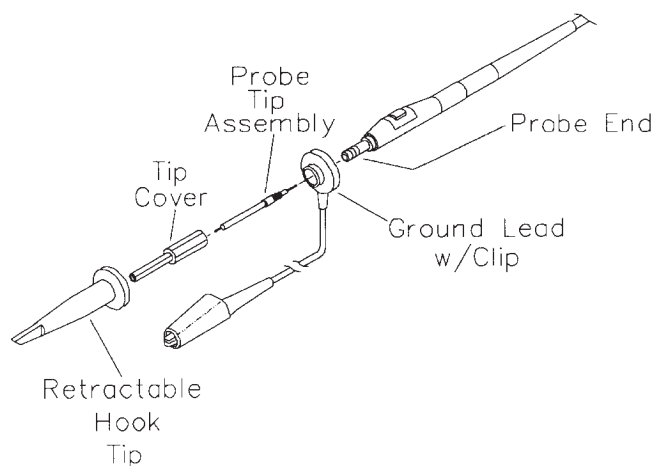
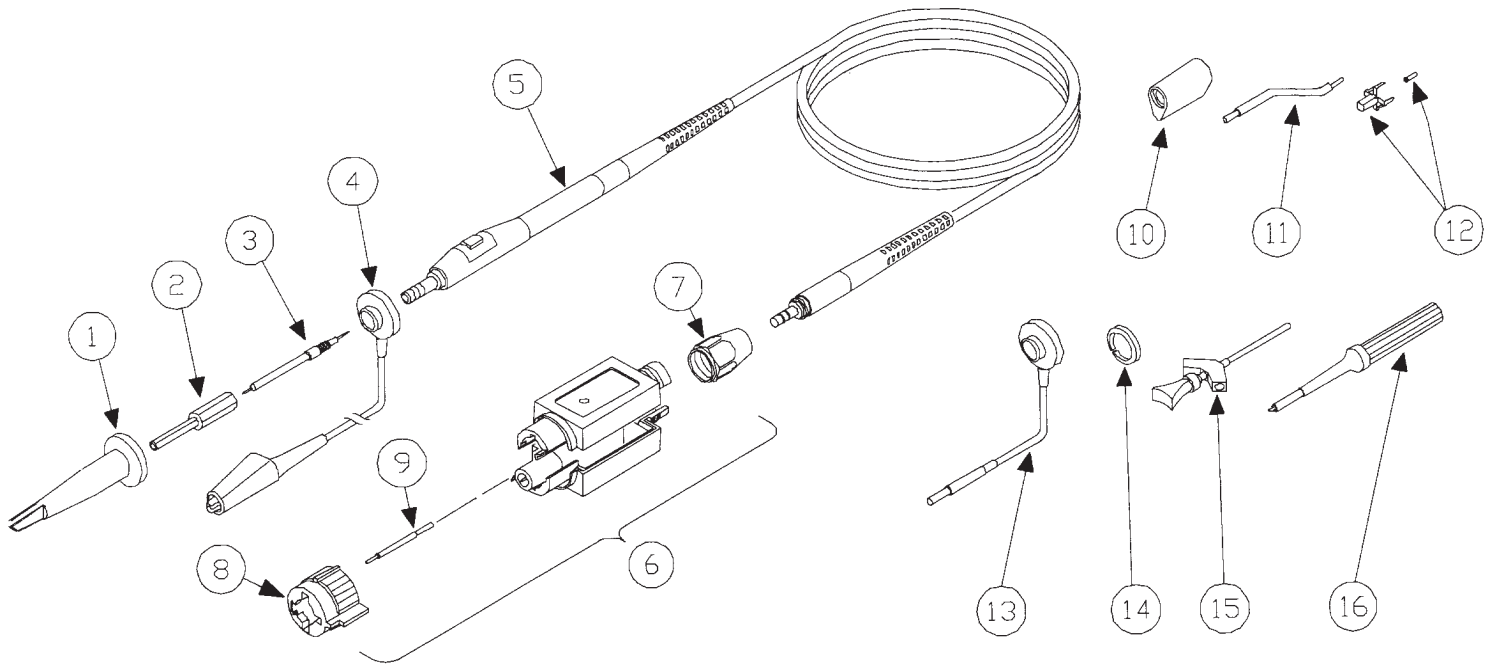

Figure 9: Probe tip assembly

Manufacturers cross index

Mfr. code	Manufacturer	Address	City, state, zip code
05006	20TH CENTURY BOK	3628 CRENSHAW BOULEVARD ATTN: CUSTOM DEPARTMENT	LOS ANGELES, CA 90016
060D9	UNITREK CORPORATION	3000 COLUMBIA HOUSE BLVD, SUITE 1 20	VANCOUVER, WA 98661
24931	FCI/BERG ELECTRONICS INC	RF/COAXIAL DIV 2100 EARLYWOOD DR PO BOX 547	FRANKLIN, IN 46131
52769	SPRAGUE-GOODMAN ELECT INC	1700 SHAMES DRIVE	WESTBURY, NY 11590
7X318	KASO PLASTICS INC	5720-C NE 121ST AVE, STE 110	VANCOUVER, WA 98682
80009	TEKTRONIX INC	14150 SW KARL BRAUN DR PO BOX 500	BEAVERTON, OR 97077-0001
TK1287	ENOCH MANUFACTURING COMPANY	MS 94 PO BOX 5087	PORTLAND, OR 97208-5087
TK2548	XEROX CORPORATION	14181 SW MILLIKAN WAY	BEAVERTON, OR 97005
TK2565	VISION PLASTICS INC	26000 SW PARKWAY CENTER DRIVE	WILSONVILLE, OR 97070



Replaceable parts list

Fig. & index number	Tektronix part number	Serial no. effective	Serial no. discontinued	Qty	Name & description	Mfr. code	Mfr. part number
1	013-0107-06		9139	1	TIP, PROBE: MINIATURE/COMPACT SIZE, RETRACTABLE HOOK ASSY	80009	013-0107-06
	013-0107-07	9140		1	TIP, PROBE: RETRACTABLE HOOK TIP, SLATE GRAY, FOR 5MM PROBES SAFETY CONTROLLED	TK2565	013-0107-07
2	204-1049-00			1	BODY SHELL: TIP COVER, SAFETY CONTROLLED	TK2565	204-1049-00
3	206-0378-00			1	PROBE TIP ASSY: 10X, 11.8PF, 9M OHM	80009	206-0378-00
4	344-0398-00		8935	1	CLIP, ELECTRICAL: ALLIGATOR, 0.155 L, STL CS PL	80009	344-0398-00
	196-3305-00	8936		1	LEAD, ELECTRICAL: 22 AWG, 6.0 L, WITH CLIP, SAFETY CONTROLLED	060D9	196-3305-00
5	174-1081-01		8829	1	CABLE ASSY, RF: 50 OHM COAX, 1.5MW/CONN SHELL	80009	174-1081-01
	174-1081-03	8830	8908	1	CABLE ASSY, RF: 50 OHM COAX, 1.5M L, W/CONNSHELL	80009	174-1081-03
	174-1081-04	8909		1	CABLE ASSY, RF: 50 OHM COAX, 1.5 L, W/CONN SHELL	80009	174-1081-04
6	206-0389-00		8908	1	COMP BOX ASSY: 1.5 METER, P6137	80009	206-0389-00
	206-0389-01	8909		1	COMP BOX ASSY: 1.5M, P6137	80009	206-0389-01
7	220-0099-00			1	NUT, RETAINING: CABLE/COMP BOX	TK1287	ORDER BY DESCRIPTION
8	205-0192-00		8908	1	SHELL, ELEC CONN: BNC, ACETAL, DOVE GRAY	80009	205-0192-00
	205-0192-01	8909		1	SHELL, ELEC CONN: BNC, ACETAL, DOVE GRAY	TK2565	205-0192-01

Replaceable parts list (cont.)

Fig. & index number	Tektronix part number	Serial no. effective	Serial no. discont'd	Qty	Name & description	Mfr. code	Mfr. part number
9	131-4446-01		8829	1	CONTACT,ELEC:W/INSULATION	80009	131-4446-01
	131-3685-01	8830		1	CONTACT:SPRING TIP, GOLD PLATED WITH TUBING	80009	131-3685-01
					STANDARD ACCESSORIES		
10	343-1003-01			1	COLLAR,GND:P6130,	TK2565	343-1003-01
11	195-4240-00			1	LEAD, ELECTRICAL:0.025 DIAMETER, COPPER, 2.3 L	060D9	195-4240-00
12	---				CONNECTOR,PROBE:W/SOCKET,DATA SHEET (SEE OPTIONAL ACCESSORIES)		
13	196-3113-01		8831	2	LEAD,ELECTRICAL:STRD,26 AWG,3.0 L,0-N W.CLR	80009	196-3113-01
	196-3113-03	8832	8935	2	LEAD, ELECTRICAL:STRANDED, 22 AWG, 3.0 L, SAFETY CONTROLLED	060D9	196-3113-03
	196-3113-02	8936		2	LEAD, ELECTRICAL:STRANDED, 22 AWG, 6.0 L, SAFETY CONTROLLED	060D9	196-3113-02
14	016-0633-00			1	MARKER SET,CA:2 EA VARIOUS COLORS	7X318	PAI-790
15	013-0217-00		8820	1	GRABBER,IC LEAD:BLACK,2.047 L X 0.137 DIA	80009	013-0217-00
	206-0364-00	8821		1	TIP,PROBE:MICROCKT TEST,0.05 CTR	TK2565	206-0364-00
16	003-1417-00		8844	1	SCREWDRIVER:ADJ TOOL,METAL TIP	52769	GTT-5G
	003-1433-00	8845		1	TOOL:ADJUSTMENT,METAL TIP, PLASTIC, BLACK	TK2565	003-1433-00
	016-0708-00			1	POUCH,ACCESSORY:6.25 X 9.25	05006	501494
	070-6432-03			1	MANUAL,TECH:INSTRUCTION,P6137	TK2548	070-6432-03
					OPTIONAL ACCESSORIES		
	013-0202-02			1	ADAPTER,PROBE:SUBMINIATURE/COMPACT TO MINI	TK2565	013-0202-02
	013-0226-00			1	CONNECTOR:BNC TO PROBE TIP ADAPTER STRAIGHT THROUGH	24931	28P264-2
	013-0227-00			1	CONNECTOR, BNC:50 OHM, BNC TO PROBE TIP ADAPTER	24931	28P312-1
	016-0633-00			1	MARKER SET,CA:2 EA VARIOUS COLORS	7X318	PAI-790
	196-3113-00		8831	1	LEAD,ELECTRICAL:STRD,26 AWG,6.0 L,0-N W/CLR	80009	196-3113-00
	196-3113-02	8832	8935	1	LEAD,ELECTRICAL:STRD,22 AWG,6.0 L,SFTY CNTR	060D9	196-3113-02
	196-3113-03	8936		1	LEAD,ELECTRICAL:STRD,22 AWG,3.0 L,SFTY CNTR	060D9	196-3113-03
	003-1433-01	8845		1	TOOL:ADJUSTMENT,PKG OF 5,METAL TIP	80009	003-1433-01
	344-0398-00	8936	9125	1	CLIP,ELECTRICAL:ALLIGATOR,0.155 L,STL CS PL	80009	344-0398-00
	013-0254-00	9307		1	ADAPTER, CONNEC:BNC TO PROBE TIP, MALE, STRAIGHT, PROBE, 2.14 INCH L, INTERNAL 4.5 X 0.077 MM TH	24931	28P-302-2
	131-5031-00	8926		1	CONNECTOR, PROB:PACKAGE OF 25, COMPACT	80009	131-5031-00

