

Instructions



P6156

For 50 Ohm Oscilloscopes

070-6430-01

Warning

The servicing instructions are for use by qualified personnel only. To avoid personal injury, do not perform any servicing unless you are qualified to do so. Refer to all safety summaries prior to performing service.

Copyright © Tektronix, Inc. All rights reserved.

Tektronix products are covered by U.S. and foreign patents, issued and pending. Information in this publication supercedes that in all previously published material. Specifications and price change privileges reserved.

Printed in the U.S.A.

Tektronix, Inc., P.O. Box 1000, Wilsonville, OR 97070-1000

TEKTRONIX and TEK are registered trademarks of Tektronix, Inc.

WARRANTY

Tektronix warrants that the products that it manufactures and sells will be free from defects in materials and workmanship for a period of one (1) year from the date of purchase from an authorized Tektronix distributor. If any such product proves defective during this warranty period, Tektronix, at its option, either will repair the defective product without charge for parts and labor, or will provide a replacement in exchange for the defective product. Batteries are excluded from this warranty.

In order to obtain service under this warranty, Customer must notify Tektronix of the defect before the expiration of the warranty period and make suitable arrangements for the performance of service. Customer shall be responsible for packaging and shipping the defective product to the service center designated by Tektronix, shipping charges prepaid, and with a copy of customer proof of purchase. Tektronix shall pay for the return of the product to Customer if the shipment is to a location within the country in which the Tektronix service center is located. Customer shall be responsible for paying all shipping charges, duties, taxes, and any other charges for products returned to any other locations.

This warranty shall not apply to any defect, failure or damage caused by improper use or improper or inadequate maintenance and care. Tektronix shall not be obligated to furnish service under this warranty a) to repair damage resulting from attempts by personnel other than Tektronix representatives to install, repair or service the product; b) to repair damage resulting from improper use or connection to incompatible equipment; c) to repair any damage or malfunction caused by the use of non-Tektronix supplies; or d) to service a product that has been modified or integrated with other products when the effect of such modification or integration increases the time or difficulty of servicing the product.

THIS WARRANTY IS GIVEN BY TEKTRONIX WITH RESPECT TO THE LISTED PRODUCTS IN LIEU OF ANY OTHER WARRANTIES, EXPRESS OR IMPLIED. TEKTRONIX AND ITS VENDORS DISCLAIM ANY IMPLIED WARRANTIES OF MERCHANTABILITY OR FITNESS FOR A PARTICULAR PURPOSE. TEKTRONIX' RESPONSIBILITY TO REPAIR OR REPLACE DEFECTIVE PRODUCTS IS THE SOLE AND EXCLUSIVE REMEDY PROVIDED TO THE CUSTOMER FOR BREACH OF THIS WARRANTY. TEKTRONIX AND ITS VENDORS WILL NOT BE LIABLE FOR ANY INDIRECT, SPECIAL, INCIDENTAL, OR CONSEQUENTIAL DAMAGES IRRESPECTIVE OF WHETHER TEKTRONIX OR THE VENDOR HAS ADVANCE NOTICE OF THE POSSIBILITY OF SUCH DAMAGES.

Contacting Tektronix

Product
Support

For questions about using Tektronix measurement products, call toll free in North America:
1-800-833-9200
6:00 a.m. – 5:00 p.m. Pacific time

Or contact us by e-mail:
support@tek.com

For product support outside of North America, contact your local Tektronix distributor or sales office.

Service
Support

Contact your local Tektronix distributor or sales office. Or visit our web site for a listing of worldwide service locations.

Website

www.tektronix.com

For other
information

In North America:
1-800-833-9200
An operator will direct your call.

To write us

Tektronix, Inc.
P.O. Box 500
Beaverton, OR 97077

General Safety Summary

Review the following safety precautions to avoid injury and prevent damage to this product or any products connected to it. To avoid potential hazards, use this product only as specified.

To Avoid Fire or Personal Injury

Connect and Disconnect Properly. Do not connect or disconnect probes or test leads while they are connected to a voltage source.

Observe All Terminal Ratings. To avoid fire or shock hazard, observe all ratings and markings on the product. Consult the product manual for further ratings information before making connections to the product.

The common terminal is at ground potential. Do not connect the common terminal to elevated voltages.

Do not apply a potential to any terminal, including the common terminal, that exceeds the maximum rating of that terminal.

Do Not Operate With Suspected Failures. If you suspect there is damage to this product, have it inspected by qualified service personnel.

Do Not Operate in Wet/Damp Conditions.

Do Not Operate in an Explosive Atmosphere.

Keep Product Surfaces Clean and Dry.

Operating Basics

The P6156 (10X) is a DC to 3.5 GHz, compact size, fast-rise, low input capacitance, passive voltage probe with a constant input resistance over a wide range of frequencies. It is designed for use with wide band oscilloscope amplifiers with 50 Ω inputs, such as the Tektronix 11000 Series with the 11A71 plug-in. Options are available for 1X, 20X and 100X attenuation values. The attenuator tips are color coded for proper tip identification. An “identify” button on the probe head provides trace identity and allows control of one or more programmable functions in 11000 Series oscilloscopes. The P6156 is equipped with a BNC connector that provides trace identify and digital readout information when used with plug-ins or mainframes incorporating these features. With the appropriate adapters and interconnects, the P6156 probe can be used with sampling systems.

Probe Tip Connections

To minimize inductive effects that can cause ringing at high frequencies (see Figure 1) keep all signal and ground leads as short as possible. A good way to make probe connections is to touch the tip and ground sleeve directly to the appropriate points in the test circuit or through the bayonet ground adapter. When the ground connection cannot be made in this manner, attach a ground contact to the sleeve. If the signal originates from an instrument with a coaxial output connector, use the appropriate probe-tip adapter. The adapter provides a correct environment for the signal and eliminates noise and other electromagnetic interference.

You can use the probe hook tip in most low-frequency measurement applications without adversely affecting the display. The ground strap assembly acts as a much larger series inductor at very high frequencies. Its effect on the display may be noticeable with pulse and rise times faster than 0.3 to 0.4 nanoseconds.

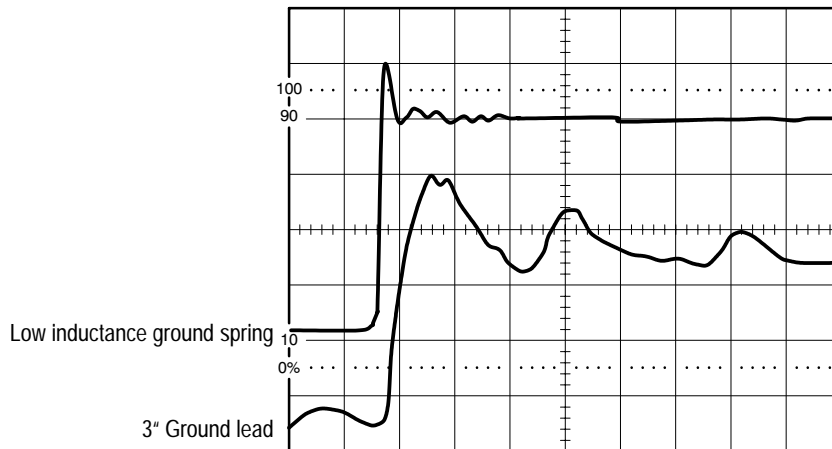

Figure 1: Ground lead effects

Use with 50 Ohm Input Oscilloscopes

P6156 probes are designed to work directly into 50 Ω wide-band oscilloscopes; no termination is necessary. For 11000 oscilloscopes, the Auto Scale Factor also indicates the correct deflection factor for signals measured at its probe tip (see the *Readout and Trace Identify* section to follow). The specifications and derating information listed in the *Specifications* section will apply when probes are used in this manner. Fifty-ohm systems using other than BNC connectors will require appropriate adapters between the probe connector and system input.

Use with 1 Megohm Input Oscilloscopes

High resistance inputs require external 50 Ω terminations (Tektronix part number 011-0049-01). Introduction of a termination will result in a slight signal reflection in the system (appearing at twice the cable delay time) due to the shunt capacitance of the oscilloscope in parallel with the 50 Ω termination. To reduce the effects of this reflection, add a 2X attenuator between the probe connector and the 50 Ω termination. This will decrease the reflection by a factor of four while increasing the attenuation by a factor of two. For sine wave measurements, the 2X attenuator is recommended to minimize standing waves.

Readout and Trace Identify

When connected to oscilloscope systems with Autoscale Factor Readout circuitry, a resistor in the probe provides information to the oscilloscope to incorporate probe attenuation into the deflection readout. In such systems, readout and trace identifying functions become inoperative if a termination,

attenuator, or adapter is inserted between the probe connector and the oscilloscope or plug-in input.

NOTE. The 20X attenuation factor autoscale readout feature is available on 11000 Series oscilloscopes only. To use the P6156 with 7000 Series, 5000 Series, 2400 Series, or other oscilloscopes, set the probe compensation box attenuator switch to 10X and multiply the scope reading by a factor of 2.

Probe Tip to BNC and SMA Termination Adapters

These adapters will terminate a 50 Ω system while providing the system voltage at a special probe tip receptacle. Since the terminating resistor and 50 Ω line are in parallel (as seen by the probe tip), the effective source impedance for the probe will be 25 Ω .

Maximum Voltage and Power Input

The DC power rating for P6156 probes is 0.5 watt. The corresponding DC input voltage for each probe is listed in the *Specifications* section on page 4.

In a 50 Ω oscilloscope system, selecting AC coupling mode or using an external coupling capacitor will block DC current flow into the probe. When an external termination is used with a high-resistance input system, selecting AC coupling will not block DC current flow through the termination. Use of the AC coupling mode or an external coupling capacitor will result in some sacrifice of system low-frequency response.

At high frequencies, voltage derating as listed in the *Specifications* section applies. The RMS voltage of a pulse signal should be estimated before measurement. The pulse duration, duty factor, and DC level determine the RMS signal voltage.

Peak voltages up to 500 volts may be measured with P6156 probes, provided the RMS equivalent is no greater than the DC maximum input voltage listed in the *Specifications* section. In no case should any portion of the signal exceed the listed DC input rating for longer than 1 millisecond.

Specifications

The following specifications apply when the instrument warms up for a period of at least 20 minutes in an environment that does not exceed the limits described in Table 2 below.

Table 1: Electrical characteristics

Characteristic	1X	10X	20X	100X
Attenuation Tolerance ^{1,2}	±5%	±3%	±3%	±3%
Input Resistance ^{1,2}	50 Ω ±5%	500 Ω ±3%	1000 Ω ±3%	5000 Ω ±3%
Input Capacitance	N/A	≤1 pF	≤1 pF	≤2.1 pF
Maximum Continuous Nondestructive Input Voltage	15 V _{RMS}	15 V _{RMS}	22 V _{RMS}	50 V _{RMS}
Probe Bandwidth ³	≥1.5 GHz	≥3.5 GHz	≥3.5 GHz	≥1.5 GHz
Rise Time ⁴	≤300 ps	≤100 ps	≤100 ps	≤233 ps
Signal Delay	7.75 ±0.05 ns	7.75 ±0.05 ns	7.75 ±0.05 ns	7.75 ±0.05 ns

- 1 System characteristic.
- 2 Oscilloscope input 50 Ω ±1%.
- 3 See Figure 2.
- 4 Probe only.

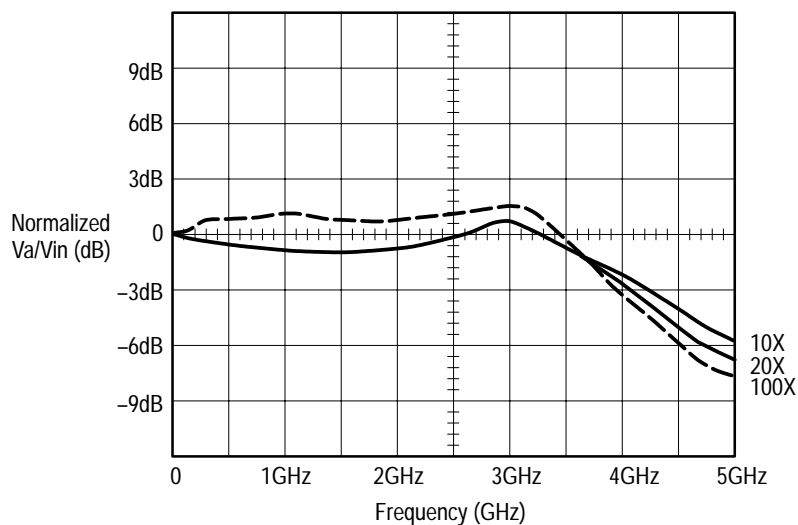

Figure 2: P6156 frequency vs impedance

Table 2: Environmental characteristics

Characteristic	Description
Temperature Range	
Operating	-15° C to +55° C (+5° F to +131° F)
Nonoperating	-62° C to +85° C (-80° F to +185° F)
Humidity ¹	Five cycles (120 hr) at 95% to 97% relative humidity 30° C to 60° C

¹ Reference to MIL-E-1600F, paragraph 4.5.9 through 4.5.9.5.1, class 3.

Table 3: Physical characteristics

Characteristic	Description
Length	1.5 m (4.9 ft.)
Shipping Weight	.907 kg (2 lbs.)

Table 4: Certifications and compliances

Underwriters Laboratories	The P6156 probe is UL listed.
---------------------------	-------------------------------

Replaceable Parts

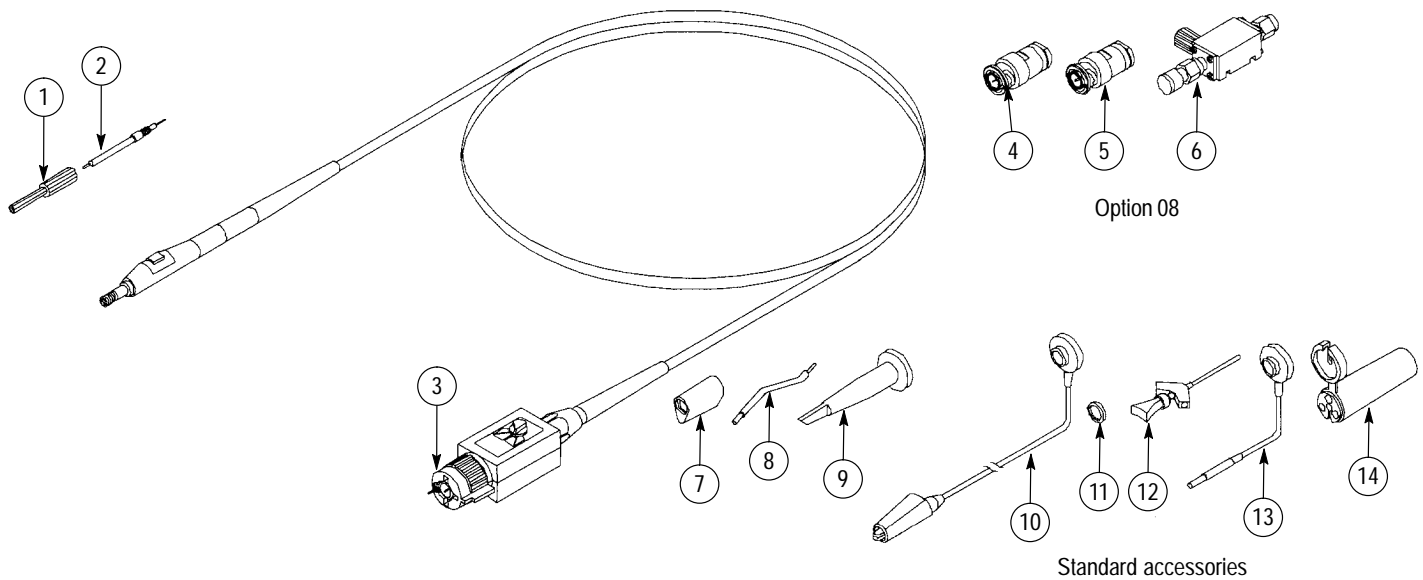

Figure 3: P6156 probe with accessories

Replaceable parts: P6156 probe and accessories

Fig. & index number	Tektronix part number	Serial no. effective	Serial no. discont'd	Qty	Name & description	Mfr. code	Mfr. part number
P6156 STANDARD (10X)							
3-1	204-1049-00			1	BODY SHELL:TIP COVER	TK2565	204-1049-00
-2	206-0308-00			1	PROBE HEAD:2.0 METER	80009	206-0308-00
-3	131-3685-01			1	CONTACT,ELEC:SPRING TIP,GOLD PLATED	80009	131-3685-01
OPTION 25 (ADDS 100X ATTENUATOR)							
3-1	204-1049-00			1	BODY SHELL:TIP COVER	TK2565	204-1049-00
-2	206-0380-00			1	PROBE TIP ASSY:10X H2294	80009	206-0380-00
	206-0382-00			1	PROBE TIP ASSY:100X H2296	80009	206-0382-00
-3	131-3685-01			1	CONTACT,ELEC:SPRING TIP,GOLD PLATED	80009	131-3685-01
OPTION 26 (ADDS 20X ATTENUATOR)							
3-1	204-1049-00			1	BODY SHELL:TIP COVER	TK2565	204-1049-00
-2	206-0380-00			1	PROBE TIP ASSY:10X H2294	80009	206-0380-00
	206-0381-00			1	PROBE TIP ASSY:20X H2295	80009	206-0381-00
-3	131-3685-01			1	CONTACT,ELEC:SPRING TIP,GOLD PLATED	80009	131-3685-01

Replaceable parts: P6156 probe and accessories (Cont.)

Fig. & index number	Tektronix part number	Serial no. effective	Serial no. discont'd	Qty	Name & description	Mfr. code	Mfr. part number
OPTION 27 (ADDS 1X ATTENUATOR)							
3-1	204-1049-00			1	BODY SHELL:TIP COVER	TK2565	204-1049-00
-2	206-0380-00			1	PROBE TIP ASSY:10X H2294	80009	206-0380-00
	206-0379-00			1	PROBE TIP ASSY:1X H2293	80009	206-0379-00
-3	131-3685-01			1	CONTACT,ELEC:SPRING TIP,GOLD PLATED	80009	131-3685-01
OPTION 28 (ADDS 1X,10X,100X ATTENUATOR)							
3-1	204-1049-00			1	BODY SHELL:TIP COVER	TK2565	204-1049-00
-2	206-0380-00			1	PROBE TIP ASSY:10X H2294	80009	206-0380-00
	206-0379-00			1	PROBE TIP ASSY:1X H2293	80009	206-0379-00
	206-0381-00			1	PROBE TIP ASSY:20X H2295	80009	206-0381-00
	206-0382-00			1	PROBE TIP ASSY:100X H2296	80009	206-0382-00
-3	131-3685-01			1	CONTACT,ELEC:SPRING TIP,GOLD PLATED	80009	131-3685-01
OPTION 08 (ADDS ENG.KIT)							
3-1	204-1049-00			1	BODY SHELL:TIP COVER	TK2565	204-1049-00
-2	206-0380-00			1	PROBE TIP ASSY:10X H2294	80009	206-0380-00
-3	131-3685-01			1	CONTACT,ELEC:SPRING TIP,GOLD PLATED	80009	131-3685-01
-4	013-0226-00			1	CONNECTOR,BNC:BNC TO PROBE TIP ADAPTER	24931	28P264-2
-5	013-0227-00			1	CONNECTOR,BNC:50 OHM,BNC TO PROBE TIP	24931	28P312-1
-6	013-0237-00			1	ADPTR,PROBE TIP:SMA TO COMPACT SIZE GHZ	64537	JA115S
STANDARD ACCESSORIES							
	020-1539-00			1	ACCESSORY PKG:P6156	80009	020-1539-00
-7	343-1003-01			1	COLLAR,GND:P6130	TK2565	343-1003-01
-8	195-4240-00			1	LEAD,ELECTRICAL:0.025 DIA,COPPER,2.3 L	TK2469	195-4240-00
-9	013-0107-06		9139	1	TIP,PROBE:MINIATURE/COMPACT SIZE,	80009	013-0107-06
	013-0107-07	9140		1	TIP,PROBE:MINIATURE/COMPACT SIZE	TK2565	013-0107-07
-10	344-0398-00		8935	1	CLIP,ELECTRICAL:ALLIGATOR,0.155 L,STL CS PL	80009	344-0398-00
	196-3305-00	8936		1	LEAD,ELECTRICAL:22 AWG,6.0 L,W/CLIP	TK2469	196-3305-00
-11	-----			1	MARKER SET.CA:2 EA VARIOUS COLORS (SEE OPTIONAL ACCESSORIES)		
-12	206-0364-00			1	TIP,PROBE:MICROCKT TEST,0.05 CTR	80009	206-0364-00
-13	196-3113-03		8935	1	LEAD,ELECTRICAL:STRD,22 AWG,3.0 L,8-N	TK2469	196-3113-03
	196-3113-02	8936		1	LEAD,ELECTRICAL:STRD,22 AWG,6.0 L,8-N	TK2469	196-3113-02
-14	352-0670-00			1	HOLDER,PROBE:ATTENUATOR TIPS (3)	TK2565	352-0670-00
	070-6430-00			1	SHEET,TECHNICAL:INSTRUCTION,P6156,DP	TK2548	PER TEK P/N

Replaceable Parts

Replaceable parts: P6156 probe and accessories (Cont.)

Fig. & index number	Tektronix part number	Serial no. effective	Serial no. discontin'd	Qty	Name & description	Mfr. code	Mfr. part number
OPTIONAL ACCESSORIES							
-----				1	SMG50:(PKG OF 20)		
	013-0202-02			1	ADAPTER,PROBE:SUBMINIATURE/COMPACT TO	TK2565	013-0202-02
	013-0226-00			1	CONNECTOR,BNC:BNC TO PROBE TIP ADAPTER	24931	28P264-2
	013-0227-00			1	CONNECTOR,BNC:50 OHM,BNC TO P TIP	24931	28P312-1
	013-0237-00			1	ADPTR,PROBE TIP:SMA TO COMPACT SIZE	64537	JA115S
	015-1018-00			1	ADAPTER,CONN:SMA MALE TO BNC FEMALE	24931	29JP124-1
	016-0633-00			1	MARKER SET,CA:2 EA VARIOUS COLORS	80009	016-0633-00
	020-1539-00			1	ACCESSORY PKG:P6156	80009	020-1539-00
	131-3685-01			1	CONTACT,ELEC:SPRING TIP,GOLD PLATED	80009	131-3685-01
	196-3113-03			1	LEAD,ELECTRICAL:STRD,22 AWG,3.0 L,8-N	TK2469	196-3113-03
	206-0379-00			1	PROBE TIP ASSY:1X	80009	206-0379-00
	206-0380-00			1	PROBE TIP ASSY:10X	80009	206-0380-00
	206-0381-00			1	PROBE TIP ASSY:20X	80009	206-0381-00
	206-0382-00			1	PROBE TIP ASSY:100X	80009	206-0382-00
	013-0254-00	9307		1	ADAPTER,CONN:BNC TO PROBE TIP,MALE	24931	28P-302-2
	131-5031-00	8926		1	CONNECTOR,PROBE:PKG OF 25,COMPACT	8009	131-5031-00

Manufacturers cross index

Mfr. code	Manufacturer	Address	City, state, zip code
24931	BERG ELECTRONICS INC	BERG ELECTRONICS RF/COAXIAL DIV 2100 EARLYWOOD DR PO BOX 547	FRANKLIN, IN 46131
64537	KDI/TRIANGLE ELECTRONICS INC	60 S JEFFERSON RD	WHIPPANY, NJ 07981
80009	TEKTRONIX INC	14150 SW KARL BRAUN DR PO BOX 500	BEAVERTON, OR 97077-0001
TK2469	UNITREK CORPORATION	3000 LEWIS & CLARK HWY SUITE 2	VANCOUVER, WA 98661
TK2548	XEROX CORPORATION	14181 SW MILLIKAN WAY	BEAVERTON, OR 97005
TK2565	VISION PLASTICS INC	26000 SW PARKWAY CENTER DRIVE	WILSONVILLE, OR 97070