

User Manual



WFM90D and WFM91D Handheld Waveform, Vector, Picture, and Audio Monitor

071-1142-01

This document supports firmware version 2.14
and above.

www.tektronix.com

Copyright © Tektronix, Inc. All rights reserved.

Tektronix products are covered by U.S. and foreign patents, issued and pending. Information in this publication supercedes that in all previously published material. Specifications and price change privileges reserved.

Tektronix, Inc., P.O. Box 500, Beaverton, OR 97077

TEKTRONIX and TEK are registered trademarks of Tektronix, Inc.

WARRANTY

Tektronix warrants that the products that it manufactures and sells will be free from defects in materials and workmanship for a period of one (1) year from the date of shipment. If a product proves defective during this warranty period, Tektronix, at its option, either will repair the defective product without charge for parts and labor, or will provide a replacement in exchange for the defective product.

In order to obtain service under this warranty, Customer must notify Tektronix of the defect before the expiration of the warranty period and make suitable arrangements for the performance of service. Customer shall be responsible for packaging and shipping the defective product to the service center designated by Tektronix, with shipping charges prepaid. Tektronix shall pay for the return of the product to Customer if the shipment is to a location within the country in which the Tektronix service center is located. Customer shall be responsible for paying all shipping charges, duties, taxes, and any other charges for products returned to any other locations.

This warranty shall not apply to any defect, failure or damage caused by improper use or improper or inadequate maintenance and care. Tektronix shall not be obligated to furnish service under this warranty a) to repair damage resulting from attempts by personnel other than Tektronix representatives to install, repair or service the product; b) to repair damage resulting from improper use or connection to incompatible equipment; c) to repair any damage or malfunction caused by the use of non-Tektronix supplies; or d) to service a product that has been modified or integrated with other products when the effect of such modification or integration increases the time or difficulty of servicing the product.

THIS WARRANTY IS GIVEN BY TEKTRONIX IN LIEU OF ANY OTHER WARRANTIES, EXPRESS OR IMPLIED. TEKTRONIX AND ITS VENDORS DISCLAIM ANY IMPLIED WARRANTIES OF MERCHANTABILITY OR FITNESS FOR A PARTICULAR PURPOSE. TEKTRONIX' RESPONSIBILITY TO REPAIR OR REPLACE DEFECTIVE PRODUCTS IS THE SOLE AND EXCLUSIVE REMEDY PROVIDED TO THE CUSTOMER FOR BREACH OF THIS WARRANTY. TEKTRONIX AND ITS VENDORS WILL NOT BE LIABLE FOR ANY INDIRECT, SPECIAL, INCIDENTAL, OR CONSEQUENTIAL DAMAGES IRRESPECTIVE OF WHETHER TEKTRONIX OR THE VENDOR HAS ADVANCE NOTICE OF THE POSSIBILITY OF SUCH DAMAGES.



Table of Contents

General Safety Summary	vii
Preface	ix
Manual Conventions	ix
Contacting Tektronix	x

Getting Started

Product Description	1-1
Features	1-1
More Information	1-3
Options and Accessories	1-5
Options	1-5
Accessories	1-6
Installation	1-7
Electrical Installation	1-7
Power Source	1-7
Recharging the NiMH Batteries	1-8
Replacing the Alkaline Batteries	1-10
Mechanical Installation	1-11
Viewing Hood	1-11
Desk Stand	1-12
Travel Case	1-13
Incoming Inspection	1-14
Packaging for Shipment	1-15

Operating Basics

Functional Overview	2-1
Keypad Controls	2-1
Power Switch	2-1
Display Mode Selection	2-1
Menu Control	2-3
Arrow Buttons	2-4
Instrument Reset	2-4

Table of Contents

Side-Panel Connectors and Switches	2-5
Video Input and Output Connectors	2-5
Audio Input and Output Connectors	2-5
DC Power Input Connector	2-5
Onscreen Readouts	2-7
Readout Description	2-7
Operating Information	2-11
Amplitude Alarm Mode	2-11
Audio Display Mode	2-11
Battery or AC Adapter Operation	2-12
Cable Report	2-12
Calibration Mode	2-13
CRC Watch	2-13
Display	2-15
EDH Report	2-15
Input/Output	2-16
Line Select Mode	2-17
Picture Display Mode	2-17
Preset Menu	2-17
Time-Out Mode	2-18
Backlight Time-Out	2-18
Instrument Power Time-Out	2-18
Variable Gain Mode	2-18
Vector Display Mode	2-19
Gain	2-19
Video Input Control	2-19
Viewing Serial Digital Signals	2-19
Waveform Display Mode	2-20
Video Input Control	2-20
Viewing Serial Digital Signals	2-20
Waveform-in-Picture Display Mode	2-21
Video Input Control	2-21
Viewing Serial Digital Signals	2-21

Using the Menu	2-23
Operating Menu	2-25
Accessing Menus	2-25
Accessing Digital Menus	2-25
Using the Menu	2-25
Waveform Menu	2-26
Vector Menu	2-27
Audio Menu	2-28
Picture Menu	2-29
WIP Menu (Waveform-in-Picture)	2-30
Configuration Menu	2-31
Configure Menu Access	2-31
Using the Menu	2-31
Line Select Menu	2-37
Tutorial	2-39
Required Equipment	2-39
Initial Equipment Connections	2-40
Procedure	2-40
Restoring Factory Default Settings	2-40
Adjusting the Display	2-41
Using the Waveform Monitor	2-41
Using the Vectorscope	2-46
Using the Picture Monitor	2-48
Using the Waveform-in-Picture (WIP) Display	2-50
Using the Audio Monitor	2-51
Using the Amplitude Alarm	2-52
Using the Presets	2-52
Using the Time-Out Mode	2-53

Reference

Reference	3-1
Waveform Graticule	3-1
Horizontal Scale	3-2
Vertical Scales	3-2
Making Waveform Measurements	3-3
Standard Measurements	3-3
Peak White	3-3
DC Restorer	3-3
Vector Graticule	3-4
Chrominance Vector Targets	3-5
Differential Phase and Gain Measurement Box	3-5
Making Vector Measurements	3-7
Chroma Bandwidth	3-7
Stress Testing	3-8
Audio Graticule	3-9
Making Audio Measurements	3-10
Signal Amplitude	3-10
Frequency Response	3-10
Headroom	3-10

Appendices

Appendix A: Specifications	A-1
Electrical Characteristics	A-2
Physical Characteristics	A-11
Environmental Characteristics	A-11
Certification	A-13
Appendix B: User Service	B-1
Fuse Replacement	B-1
Battery Replacement	B-1
Cleaning and Maintenance	B-1
Display	B-2
Instrument Adjustment	B-2

Glossary

Index

List of Figures

Figure 1-1: Removing the NiMH battery pack	1-9
Figure 1-2: Inside of the battery compartment, showing polarity markings	1-10
Figure 1-3: Installing the viewing hood	1-11
Figure 1-4: Installing the desk stand	1-12
Figure 1-5: Packing the Option 33 travel case	1-13
Figure 2-1: WFM90D keypad	2-2
Figure 2-2: WFM90D and WFM91D side panels	2-6
Figure 2-3: Onscreen readout messages	2-7
Figure 2-4: Waveform and Vector menus	2-23
Figure 2-5: Audio, Picture, and Waveform-in-Picture menus	2-24
Figure 2-6: Line Select menu	2-24
Figure 2-7: Configuration menu	2-32
Figure 3-1: NTSC waveform graticule	3-1
Figure 3-2: PAL waveform graticule	3-2
Figure 3-3: NTSC vector graticule	3-4
Figure 3-4: PAL vector graticule	3-5
Figure 3-5: Vector targets - NTSC values (PAL values in parentheses)	3-6
Figure 3-6: Differential gain and phase measurement box .	3-6
Figure 3-7: Audio graticule with -3 dB headroom selected	3-9
Figure 3-8: Audio graticule with +10 dB headroom selected	3-9

List of Tables

Table 1-1: Options	1-5
Table 1-2: Standard accessories	1-6
Table 1-3: Optional accessories	1-6
Table 2-1: Video readout messages	2-9
Table 2-2: Waveform menu choices, analog and digital ...	2-26
Table 2-3: Vector menu choices, analog and digital	2-27
Table 2-4: Audio menu choices	2-28
Table 2-5: Picture menu choices, analog and digital	2-29
Table 2-6: WIP menu choices, analog and digital	2-30
Table 2-7: Configure menu choices	2-33
Table 2-8: Default instrument settings	2-36
Table 2-9: Line Select menu choices	2-37
Table A-1: Vertical deflection system	A-2
Table A-2: DC restoration	A-6
Table A-3: Audio mode	A-6
Table A-4: Horizontal deflection system	A-7
Table A-5: Vector mode	A-8
Table A-6: Synchronization	A-9
Table A-7: Power source	A-10
Table A-8: Physical characteristics	A-11
Table A-9: Environmental characteristics	A-11
Table A-10: Certifications and compliances	A-13

General Safety Summary

Review the following safety precautions to avoid injury and prevent damage to this product or any products connected to it. To avoid potential hazards, use this product only as specified.

Only qualified personnel should perform service procedures.

To Avoid Fire or Personal Injury

Connect and Disconnect Properly. Do not connect or disconnect probes or test leads while they are connected to a voltage source.

Observe All Terminal Ratings. To avoid fire or shock hazard, observe all ratings and markings on the product. Consult the product manual for further ratings information before making connections to the product.

Replace Batteries Properly. Replace batteries only with the proper type and rating specified.

Recharge Batteries Properly. Recharge batteries for the recommended charge cycle only.

Use Proper AC Adapter. Use only the AC adapter specified for this product.

Do Not Operate Without Covers. Do not operate this product with covers or panels removed.

Use Proper Fuse. Use only the fuse type and rating specified for this product.

Avoid Exposed Circuitry. Do not touch exposed connections and components when power is present.

Do Not Operate With Suspected Failures. If you suspect there is damage to this product, have it inspected by qualified service personnel.

Do Not Operate in Wet/Damp Conditions.

Do Not Operate in an Explosive Atmosphere.

Keep Product Surfaces Clean and Dry.

Safety Terms and Symbols

Terms in This Manual. These terms may appear in this manual:



WARNING. *Warning statements identify conditions or practices that could result in injury or loss of life.*



CAUTION. *Caution statements identify conditions or practices that could result in damage to this product or other property.*

Terms on the Product. These terms may appear on the product:

DANGER indicates an injury hazard immediately accessible as you read the marking.

WARNING indicates an injury hazard not immediately accessible as you read the marking.

CAUTION indicates a hazard to property including the product.

Symbols on the Product. These symbols may appear on the product:



CAUTION
Refer to Manual



Double
Insulated

Battery Recycling

This product contains a Nickel battery, which must be recycled or disposed of properly. For the location of a local battery recycler in the U.S. or Canada, please contact:

RBRC
Rechargeable Battery Recycling Corp.
P.O. Box 141870
Gainesville, Florida 32614

(800) BATTERY
(800) 227-7379
www.rbrc.com



Preface

This manual is a guide for operators of the WFM90D and WFM91D Handheld Waveform, Vector, Picture, and Audio Monitor.

Manual Structure

This manual contains the following information:

Getting Started provides a product description and a list of available options and accessories.

Operating Basics describes installation, basic instrument operation, instrument controls and connectors, and general menu features.

Reference describes each menu selection and explains the different graticules and how to use them to make measurements.

Appendix A lists electrical and mechanical instrument specifications, as well as standards compliance.

Appendix B provides instructions for preventive maintenance of the instrument.

Manual Conventions

Throughout this manual, instrument controls and display readouts appear in ALL CAPITALS.

Contacting Tektronix

Phone	1-800-833-9200*
Address	Tektronix, Inc. Department or name (if known) 14200 SW Karl Braun Drive P.O. Box 500 Beaverton, OR 97077 USA
Web site	www.tektronix.com
Sales support	1-800-833-9200, select option 1*
Service support	1-800-833-9200, select option 2*
Technical support	www.tektronix.com/support 1-800-833-9200, select option 3* 6:00 a.m. – 5:00 p.m. Pacific Standard Time

* **This phone number is toll free in North America. After office hours, please leave a voice mail message. Outside North America, contact a Tektronix sales office or distributor; see the Tektronix web site for a list of offices.**



Getting Started

Product Description

The handheld, self-contained, Tektronix WFM90D and WFM91D television waveform monitors can monitor analog and digital signals. The monitors provide composite and component waveform displays as well as vector and picture displays.

These monitors can be used in the traditional in-house applications of television production, post-production, and signal transmission. In addition, their portability allows them to be used in non-traditional applications such as field production and system maintenance.

Features

- Accepts NTSC/PAL composite video or 525/625 Component 270 Mbit serial digital video signals
- Automatic detection of analog or serial digital signals
- Built-in color display (TFT LCD)
- Viewing angle control
- Electronic graticules
- Battery or AC adapter powered
- Menu-assisted monitoring operation
- Audio signal input/output
- Waveform, Vector, Picture, Audio, and Waveform-in-Picture display modes
- Line select lets you view any single line of video
- Selectable time out for backlight or instrument power
- Signal level alarm mode for waveform and audio displays
- Preset menu to store/recall front panel and menu setups
- Instrument adjustments from front panel (see service manual)

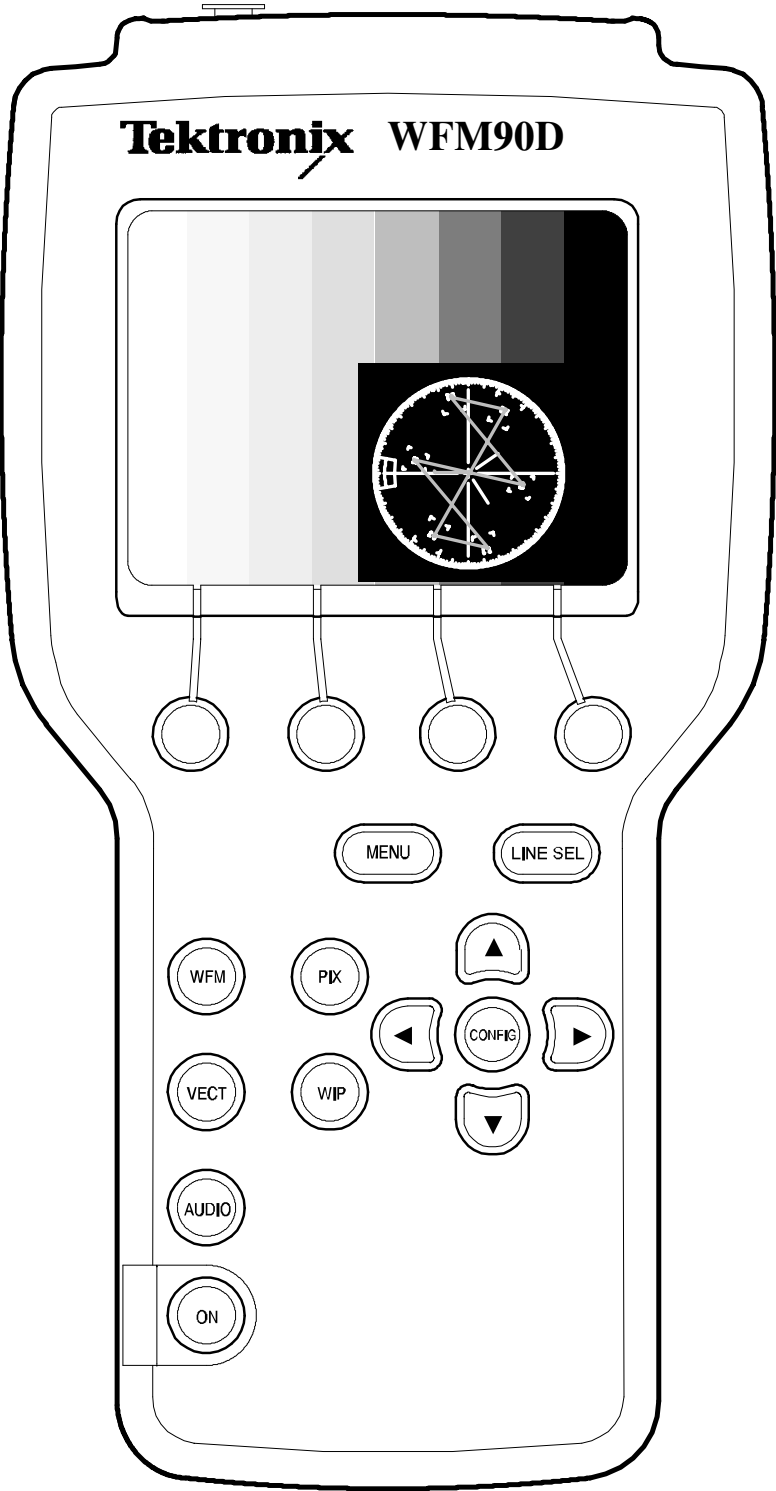

More Information

- Instrument options and accessories, as well as ordering information, are listed beginning on page 1-5.
- Battery operation is discussed beginning on page 1-7.
- A tutorial covering basic instrument operation starts on page 2-39.
- Detailed menu descriptions begin on page 2-25.
- A complete listing of instrument performance specifications is located in *Appendix A*.

Options and Accessories

This section lists the options and accessories for the WFM90D and WFM91D. You can order options and accessories with the monitor or purchase them separately through a Tektronix field office or distributor. When ordering, include the option or part number and the description.

Options

You can order the following options with the WFM90D and WFM91D. When ordering replacement power adapters, use the Tektronix part numbers listed in Table 1-1.

Table 1-1: Options

Option	Description	Tektronix part number
Option 01	NiMH battery pack	146-0107-01
Option A1	220 V wall unit power adapter, European TUV	119-4540-02
Option A2	240 V wall unit power adapter, UK	119-4541-02
Option A3	240 V wall unit power adapter, Australia	119-4542-02
Option A6	100 V wall unit power adapter, Japan	119-4539-02
Option A10	220 V wall unit power adapter, China	119-6904-00
Option A99	No power cord (WFM91D)	
Option M2	5 years warranty/remedial service	
Option M8	4 calibration/performance tests	
Option 33	Travel-line package, including: <ul style="list-style-type: none">■ NiMH battery pack■ Viewing hood■ Desk stand■ Travel case for a WFM90D or WFM91D monitor and a TSG95 or TSG601 signal generator	

Accessories

Standard accessories are shipped with every instrument. The standard accessories for the WFM90D and WFM91D and the Tektronix part numbers to use when ordering are listed in Table 1-2.

Table 1-2: Standard accessories

Description	Quantity	Tektronix part number
<i>WFM90D and WFM91D Handheld Waveform, Vector, Picture, & Audio Monitor User Manual</i>	1 ea	071-1142-00
120 V wall unit power adapter, North American	1 ea	119-4538-01
Carrying pouch	1 ea	116-1330-01

Table 1-3: Optional accessories

Description	Tektronix part number
<i>WFM90D and WFM91D Handheld Waveform, Vector, Picture, & Audio Monitor Service Manual</i>	071-1143-00
NiMH battery pack	146-0107-01
Instrument desk stand	386-6787-01
Viewing hood	011-0167-01
Travel case for a WFM90D or WFM91D monitor and a TSG95 or TSG601 signal generator	016-1344-00
Backlight replacement kit	150-0215-00

Installation

This section describes mechanical and electrical installation and packaging for shipment.

Electrical Installation

Instrument Configuration

There are no internal jumper settings for these monitors. Instrument configuration is through the CONFIG menu (refer to page 2-31).

Power Source

The WFM90D and WFM91D handheld monitors are designed to operate from either six C-cell alkaline batteries, a rechargeable NiMH battery pack, or an AC adapter wall unit producing 12 VDC.



CAUTION. *DC Power Source*

To avoid possible damage to the instrument circuitry when using a DC power source other than the supplied AC adapter, ensure that the DC source is a negative-ground 11 - 18 V system with a negative center lead. The DC source should be able to provide 12 W of power.

Recharging the NiMH Batteries

The NiMH batteries begin to charge automatically when you plug the 12 VDC adapter into the instrument, whether instrument power is on or off. The battery charge time is 6.5 hours when the instrument is off, and 20 hours while the instrument is on. When the batteries are fully charged, the monitor goes into a safe trickle-charge mode, which can run indefinitely.

The message LOW BAT is displayed onscreen when the remaining battery power cannot guarantee reliable instrument operation. After this message appears, the monitor will operate for some length of time, which is dependent on the operating mode.

For optimal battery life and capacity, use the NiMH battery pack in full charge/discharge cycles (fully discharge the battery pack before recharging, and then charge the battery pack until it is fully charged). A new battery pack will take a few charge/discharge cycles to reach full capacity.

Replacing NiMH Batteries. The battery compartment is located under the back panel of the monitor. To open the compartment, turn the screw head at the top of the panel 1/4 turn.

The optional NiMH battery pack has a connector that fits on the jumper in the battery compartment (see Figure 1-1). To remove the battery pack, grasp the batteries close to the wire leads. Press in on the top portion of the battery connector tab and then pull up gently.

To replace the NiMH battery pack, use only the Tektronix rechargeable NiMH battery pack, part number 146-0107-01. Do not use any other battery pack.

NOTE. *To prevent a loss of battery power, be sure that the battery connector tab snaps on to the jumper housing.*

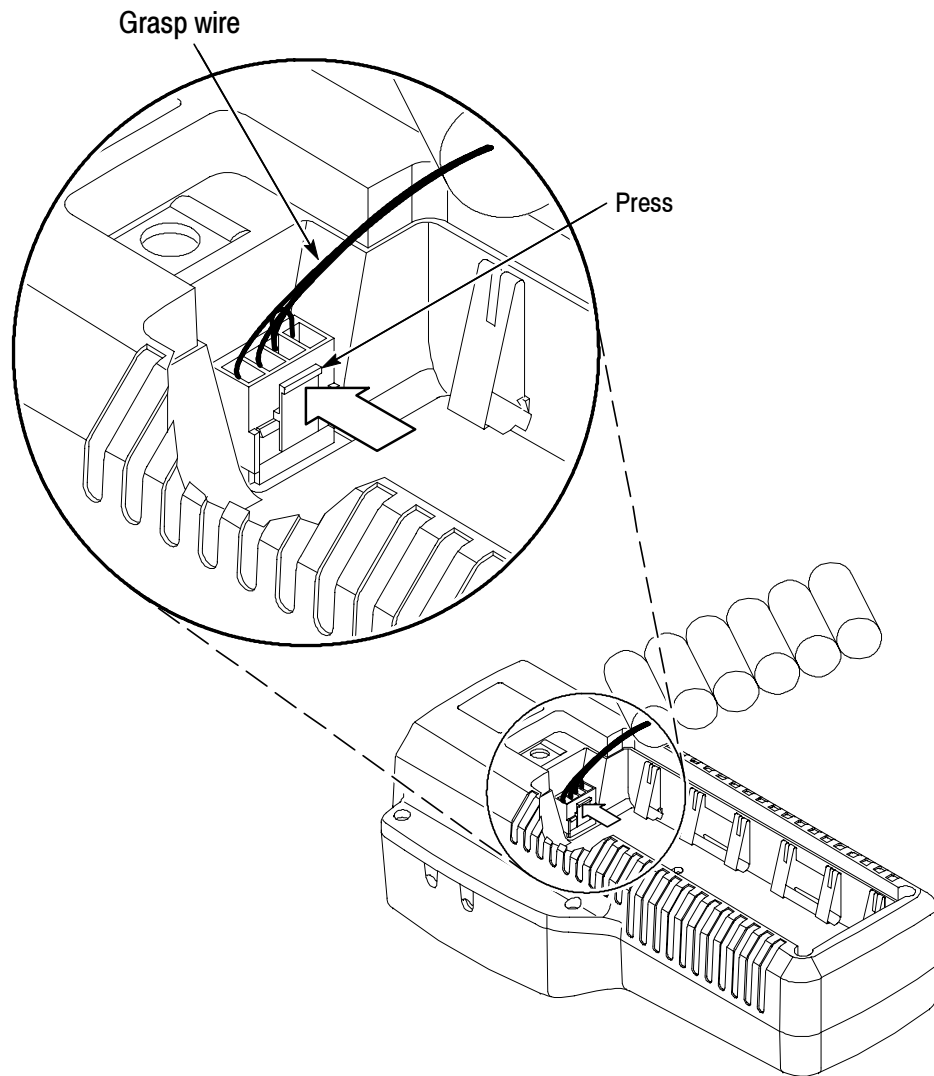

Figure 1-1: Removing the NiMH battery pack

Replacing the Alkaline Batteries

You can use six alkaline batteries to power the WFM90D and WFM91D, however, the battery life may be limited.

NOTE. Always replace all of the alkaline batteries at the same time.

The polarity of the alkaline batteries must be correct for the instrument to operate.

The battery compartment is located under the back panel of the monitor. To open the compartment, turn the screw head at the top of the panel 1/4 turn. Replace all of the batteries, following the polarity indications on the bottom of the battery compartment, which are also shown in Figure 1-2.

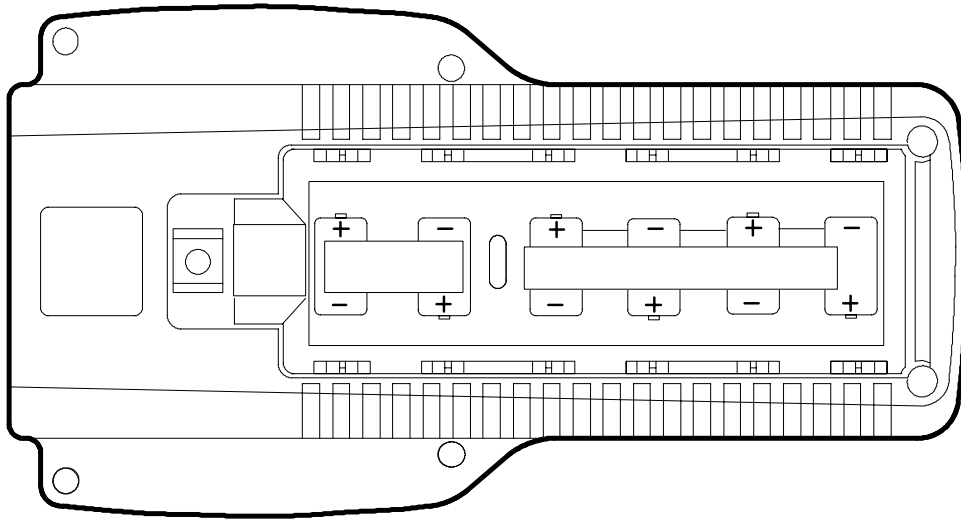

Figure 1-2: Inside of the battery compartment, showing polarity markings

Mechanical Installation

You can purchase a viewing hood and desk stand to use with your WFM90D or WFM91D.

Viewing Hood

The viewing hood makes it easier to view the instrument display in well-lighted situations.

To attach the hood to the instrument, attach the supplied Velcro strips to the sides of the instrument, and then press the flaps of the viewing hood onto the strips as shown in Figure 1-3.

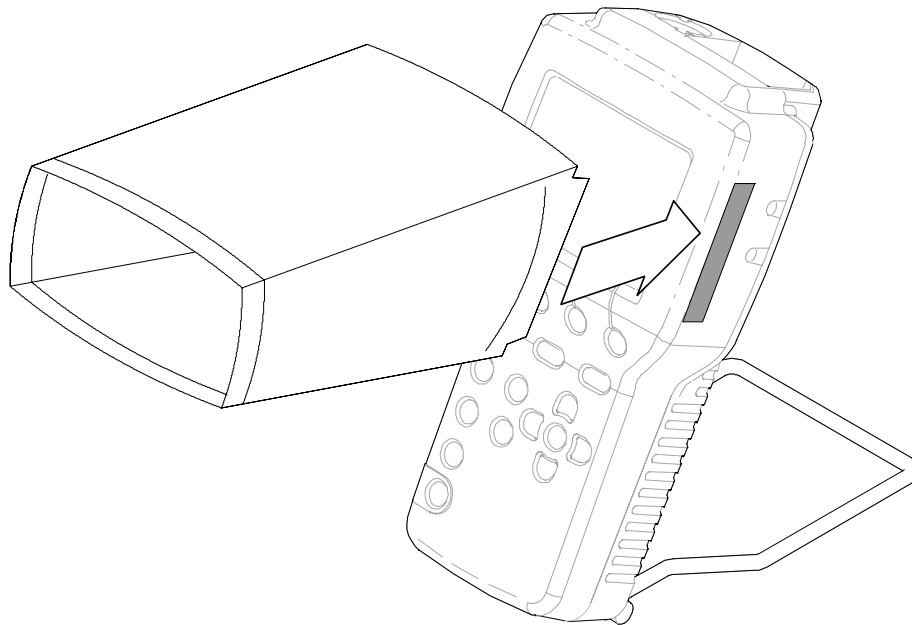

Figure 1-3: Installing the viewing hood

Desk Stand

The desk stand holds the monitor upright on a flat surface. Insert the prongs of the stand into the holes in the back of the instrument as shown in Figure 1-4.

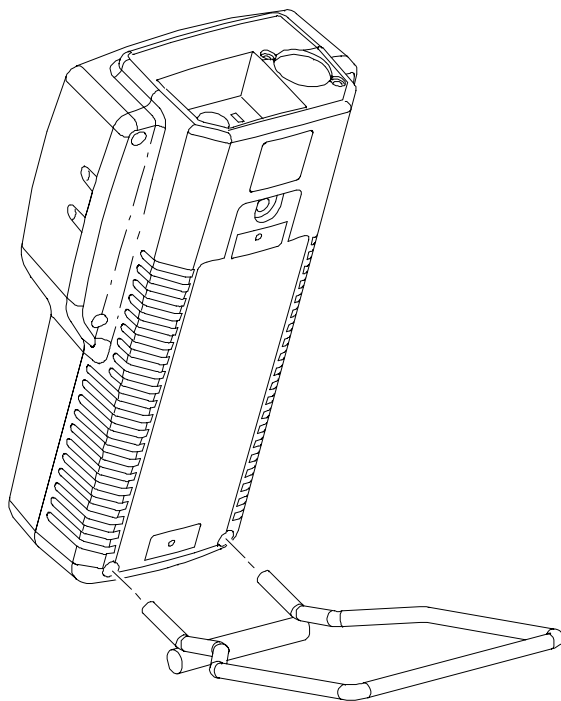

Figure 1-4: Installing the desk stand

Travel Case

The travel case (Option 33) can safely hold the handheld monitor and its accessories while traveling between locations. The case also holds a companion handheld TSG95 or TSG601 generator. The travel case compartments (see Figure 1-5) hold the following items:

1. Signal cables and user manuals for the monitor and generator.
2. Handheld monitor; viewing hood slipped around the monitor.
3. Spare batteries for the handheld monitor.
4. Spare batteries for the handheld generator.
5. Handheld generator, desk stand, and carrying straps.
6. AC adapter(s).

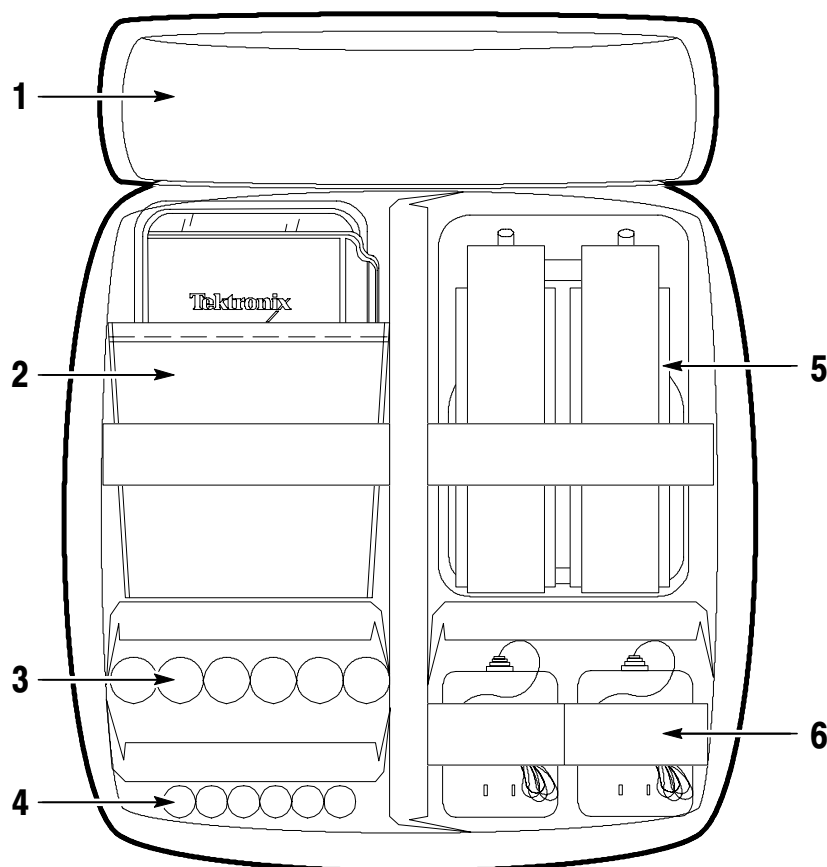

Figure 1-5: Packing the Option 33 travel case

Incoming Inspection

Save the shipping carton and packing materials in case you need to ship the monitor to a Tektronix Service Center for service or repair.

Check that the following standard accessories are included:

- User manual
- 120 V wall unit power adapter, North American
- Carrying pouch

NOTE. *If Option 33 is ordered, the monitor is placed inside the travel case for shipment.*

To check basic instrument operation, use the *Tutorial* on page 2-39.

To verify that the instrument is performing to specifications, use the Performance Verification procedure in the optional *WFM90D and WFM91D Handheld Waveform, Vector, Picture, & Audio Monitor Service Manual*.

Packaging for Shipment

If you ship an instrument to a Tektronix Service Center, follow these packaging instructions:

1. Attach a tag to the instrument showing: the owner, complete address and phone number of someone at your firm who can be contacted, the instrument serial number, and a description of the required service.
2. Package the monitor in the original packaging materials. If they are not available, follow these directions:
 - a. Use a shipping carton of corrugated cardboard having inside dimensions six or more inches greater than the dimensions of the instrument. The carton must have a test strength of at least 250 pounds.
 - b. Place the monitor in the carrying pouch or surround the instrument with a protective bag.
 - c. Pack dunnage or urethane foam between the monitor and the carton. If using Styrofoam kernels, overfill the box and compress by closing the lid. There should be three inches of tightly packed cushioning on all sides of the instrument.
3. Seal the carton with shipping tape, industrial stapler, or both.



Operating Basics

Functional Overview

This section describes the WFM90D and WFM91D controls and connectors.

Keypad Controls

The keypad (front panel) is illustrated in Figure 2-1.

Power Switch

ON. The ON button toggles the instrument power on and off. The current instrument keypad and menu selections are saved when you turn off the instrument using this button. The instrument configuration is not saved if the power source is removed before you turn off the instrument with this button.

Display Mode Selection

WFM. Pressing the WFM button enters the Waveform display mode.

VECT. Pressing the VECT button enters the Vector display mode.

AUDIO. Pressing the AUDIO button enters the Audio display mode.

PIX. Pressing the PIX button enters the Picture display mode.

WIP. Pressing the WIP button enters the Waveform-in-Picture display mode. The previously selected display mode, other than Picture, is shown in a 1/4-screen-sized window that overlays the Picture display.

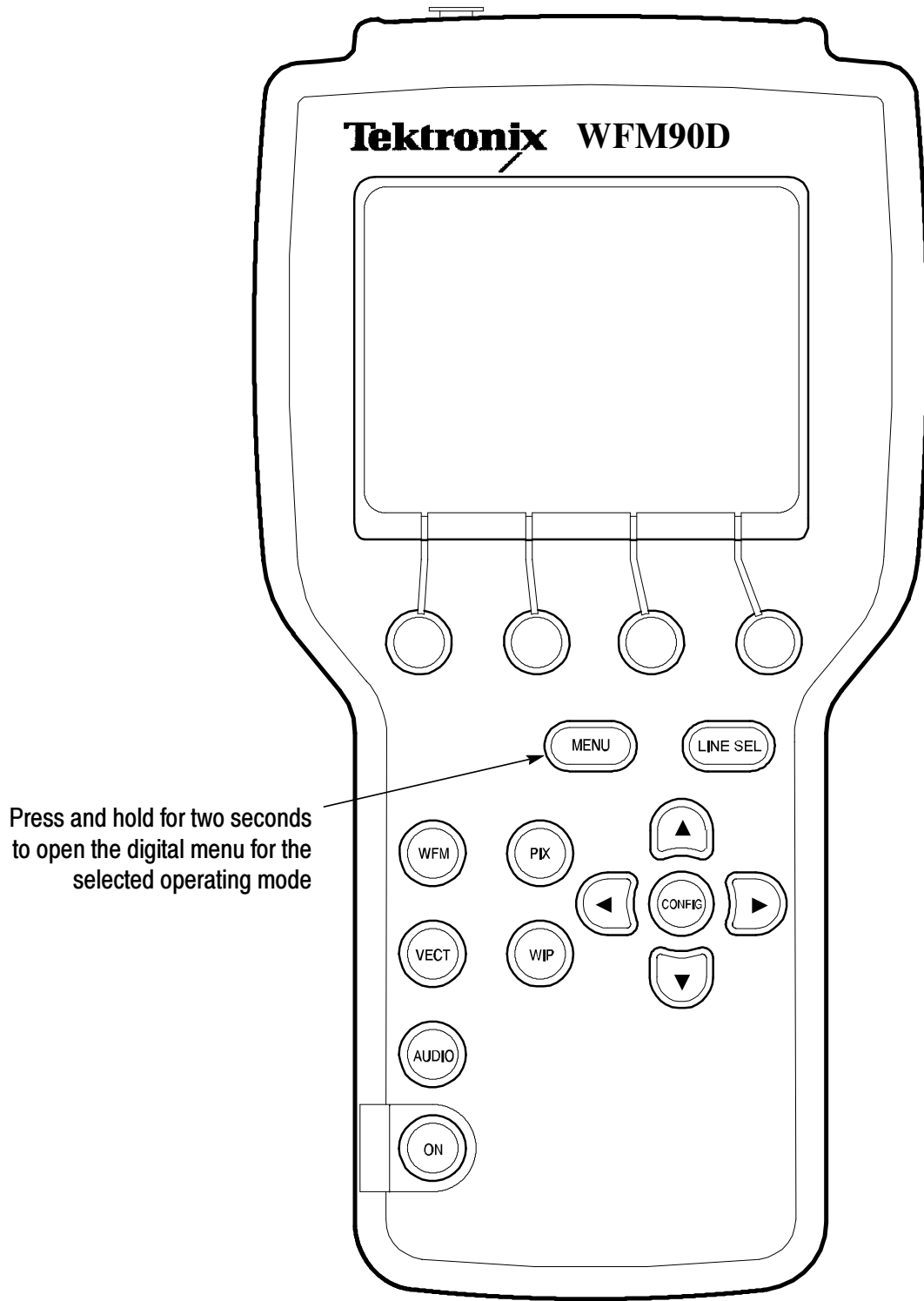

Figure 2-1: WFM90D keypad

Menu Control

The menus use a combination of onscreen readout and multi-use “bezel buttons,” in conjunction with the arrow buttons, to control most of the monitoring functions. Menus are entered by pressing one of the MENU, CONFIG, or LINE SEL buttons. Menus are exited by pressing the entry button for the open menu, or by entering another menu.

Menu operation and selections are detailed in *Using the Menus* starting on page 2-23.

MENU. Pressing the MENU button toggles an operating menu on and off. An operating menu contains monitoring selections that are specifically related to the currently selected display mode.

Digital menus. Pressing and holding the MENU button while in WFM, VECTOR, PICTURE, or WIP mode enters a digital operating menu. Operating menus are described in detail in *Operating Menus* starting on page 2-25.

CONFIG. Pressing the CONFIG button toggles the Configuration menu on and off. The Configuration menu contains selections which control overall instrument monitoring operation. Configuration menu selections are described in detail in *Configuration Menu* starting on page 2-31.

LINE SEL. Pressing the LINE SEL button toggles the Line Select mode on and off and displays the Line Select menu (shown in Table 2-9 on page 2-37).

Bezel Buttons. The four unlabeled buttons directly below the display are referred to as the bezel buttons. These buttons are used for making menu selections and are only enabled while menus are displayed on screen.

Arrow Buttons

The function of the arrow buttons is dependent on the current state of the instrument. For the Waveform and Audio display modes, they control signal positioning. For the Vector display mode, they control vector phase, with the ▲ and ▼ buttons providing fine adjustment, and the ◀ and ▶ buttons providing coarse adjustment.

The arrow buttons retain their default function for the reduced display when the Waveform-in-Picture display mode is selected. When the Configuration menu is displayed, the ▲ and ▼ buttons operate the menu category selection, while the ◀ and ▶ buttons retain their default function for the current display mode.

Instrument Reset

Extraordinary conditions may cause the WFM90D and WFM91D controls to become locked or to respond erratically. To reset the instrument, first press the ON button to turn off the power, then press the ON button again while holding down the WIP and LINE SEL buttons. The instrument should return to normal operation with the keypad controls and menu selections assigned to the factory-set defaults.

If this reset does not return the instrument to normal operation, contact your Tektronix field office or call Tektronix at the phone number listed on page *x* at the front of this manual.

Side-Panel Connectors and Switches

The WFM90D and WFM91D side panels are illustrated in Figure 2-2.

Video Input and Output Connectors

VIDEO IN. Passive BNC input, unterminated, 75 Ω compensated for a video signal. A rear-panel switch provides an internal 75 Ω signal termination.

NOTE. *A loop-through connector can be used by connecting a BNC “T” connector to the VIDEO IN BNC. Slide the rear panel switch to the HI-Z position.*

EXT REF. Passive BNC input, unterminated, 75 Ω compensated for an external sync video signal. A rear-panel switch provides an internal 75 Ω signal termination.

VIDEO OUT. A BNC connector used to output the instrument display to a remote monitor or video switcher.

Audio Input and Output Connectors

AUDIO IN. A standard three-pin XLR connector for a single channel of audio input.

Audio out. A standard stereo mini-headphone jack for the output of the audio input signal. The mono input signal is heard on both stereo channels. The audio volume is fixed for each reference level. The larger the displayed signal, the louder the volume.

DC Power Input Connector

DC IN 11 - 18 V. A 2 mm plug which accepts a 12 VDC power input using a negative center lead.



CAUTION. *DC Power Source*

To avoid possible damage to the instrument circuitry when using a DC power source other than the supplied AC adapter, ensure that the DC source is a negative-ground 11 - 18 V system with a negative center lead. The DC source should be able to provide 12 W of power.

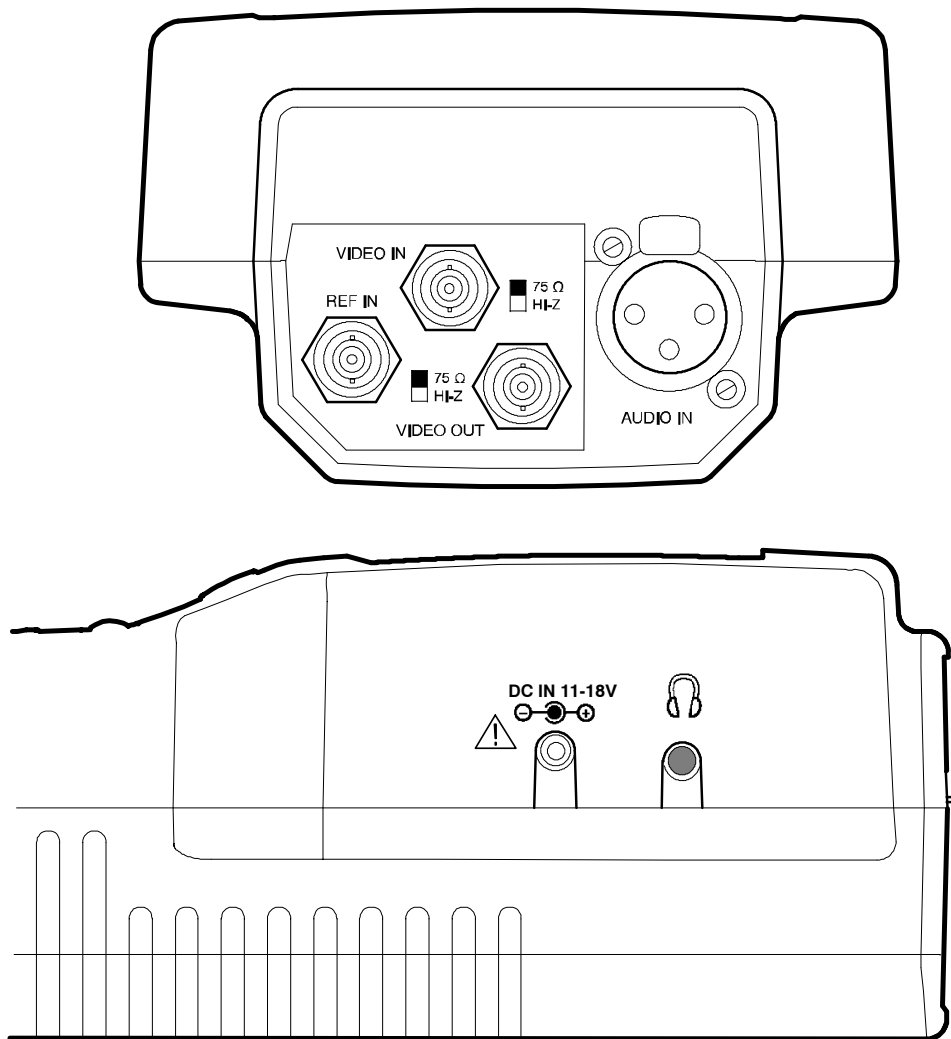

Figure 2-2: WFM90D and WFM91D side panels

Onscreen Readouts

The WFM90D and WFM91D use onscreen messages to alert you to certain monitoring conditions. Figure 2-3 shows example readout messages and their locations.

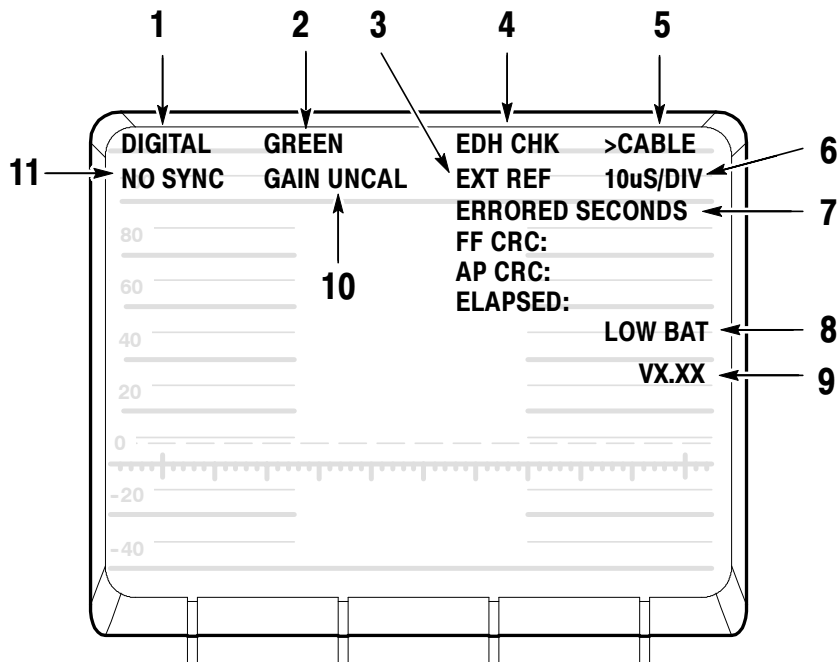

Figure 2-3: Onscreen readout messages

Readout Description

1. The video message reports the video type. Possible messages are shown in Table 2-1.
2. The component readout shows which component is selected for display through the digital Waveform menu: COMPOSITE, GREEN, BLUE, RED, Y, Pb, Pr, C. The readout only appears if digital video is locked or if INPUT CTL is set to DIGITAL.
3. The EXT REF message appears in the Waveform and Vector display modes when the video signal is locking to an external video reference signal.

4. The EDH report appears when EDH is turned on. For information about the EDH report, refer to page 2-15.
5. When the cable report is turned on (see *Configuration Menu*, page 2-31) the message displays **>CABLE** if the cable length is greater than approximately 200 meters. If the cable is shorter than 200 meters, there is no message.

NOTE. *The cable report is only available when the instrument is operating in DIGITAL mode. In ANALOG mode, there is no report.*

6. The sweep rate is only displayed in the Waveform display mode. There is no sweep rate readout when 2 Field sweep is selected.
7. When the CRC Watch is turned on, the **ERRORED SECONDS** message block appears. For information about CRC, refer to *CRC Watch* on page 2-14.
8. The **LOW BAT** message is displayed when the instrument is battery operated and the remaining battery power has reached a critically low level. The remaining length of time that the instrument can be operated reliably is dependent on the current operating mode.
9. The instrument software version number is displayed when the Configuration menu is open with the **DISPLAY** category selected.
10. The **GAIN UNCAL** message appears in the Waveform, Vector, and Waveform-in-Picture display modes when the Variable Gain is on.
11. The **MISSING SYNC** message appears in all analog video display modes when the signal reference has been lost. **NO SYNC** appears in digital modes when analog sync is missing.

Table 2-1: Video readout messages

Message	Conditions	INPUT CTRL setting
DIGITAL	Digital video locked to 525 on a WFM90D; 625 on a WFM91D	DIGITAL or AUTO
<name of video standard>	Digital video lock to an unsupported standard	DIGITAL or AUTO
ANALOG	No digital video lock	AUTO
UNLOCK	No digital video lock	DIGITAL

Operating Information

This section contains information about the different functions of the WFM90D and WFM91D. For information about using the menus to access these functions, refer to *Using the Menus* on page 2-23.

Amplitude Alarm Mode

The Amplitude Alarm mode provides a means for automatic monitoring of the signal amplitude for the Waveform and Audio displays. The mode is enabled through a menu selection in the Configuration menu.

For the Waveform display mode, the portion of the signal that exceeds the 100 IRE (1.0 V PAL) graticule line is highlighted.

For the Audio display mode, the portion of the signal that exceeds the menu-selected reference level is highlighted.

The highlighted portion of the signal is also visible in the Waveform-in-Picture (WIP) display mode.

Audio Display Mode

The Audio display mode provides a voltage-versus-time display of a single audio channel. The audio voltage is displayed on the vertical scale with time on the horizontal scale at a two-field sweep rate.

Audio reference levels can be set to -10, 0, 4, or 8 dBu, with an additional level available for microphone checks. The audio headroom reference level can be set to -3 dB or +10 dB, and is for audio signals below or above the reference level, respectively.

Battery or AC Adapter Operation

The instrument can be powered by six C-cell batteries (alkaline or NiMH), by an internally rechargeable NiMH battery pack, or by an AC adapter wall unit with a negative center lead producing 12 VDC.

The rechargeable NiMH battery pack automatically recharges when the 12 VDC adapter is plugged into the instrument, whether instrument power is on or off. Alkaline batteries are not recharged. The message LOW BAT is displayed onscreen when the batteries get critically low on power.

NOTE. *To maintain uninterrupted operation when using the wall adapter, be sure that the batteries are installed in the instrument. Refer to Installation on page 1-7.*

Only the NiMH battery pack recharges in the instrument.

Cable Report

The cable report, when enabled, provides a message in the upper right corner of the display.

>**CABLE** indicates that the cable between the signal source and the WFM90D or WFM91D is approximately 200 meters or longer. If the cable is shorter than 200 meters, there is no message.

NOTE. *The CABLE RPT is only available when the instrument is operating in DIGITAL mode. In ANALOG mode, there is no report.*

Calibration Mode



CAUTION. Do not adjust the instrument without using the instructions listed in the service manual. If you do so, your instrument may not meet the published specifications.

If you accidentally change a setting in the Calibration menu, press the MENU button to exit this menu. Do not select SAVE.

The Calibration mode lets you adjust the instrument to factory specifications, if necessary. To enter the Calibration mode, press and hold the CONFIG button for three seconds. The instrument adjustments are performed entirely from the keypad with the use of specified input signals.

The instructions for adjusting the instrument to specifications are located in the *WFM90D and WFM91D Handheld Waveform, Vector, Picture, & Audio Monitor Service Manual*.

CRC Watch

The WFM90D and WFM91D measures data transmission errors in serial video systems, using the Error Detection and Handling (EDH) system, documented by the SMPTE RP165 standard.

The EDH system computes a CRC for each field of video and includes it with the video in an ancillary data field. At the EDH receiver, a CRC is calculated for the received field of video and compared against the transmitted CRC. If they do not match, then one or more errors have occurred during that video field.

To measure a serial digital link, the source must insert EDH information. Serial repeaters or processing equipment between the source and the destination receiver must pass ancillary data on the lines where the EDH is inserted. For 525 line standards, EDH data is on lines 9 and 272 and, for 625 line standards, on lines 5 and 318. If your source can not insert EDH, use an alternative source, such as the Tektronix TSG601 Generator. This substitution is effective because sources must generate standard waveforms.

Enable CRC Watch. You can turn the CRC Watch on and off through any of the digital operating menus except Audio. When the CRC Watch is turned on, the WFM90D and WFM91D counts and reports all seconds containing at least one error (errored seconds).

The display will flash once per minute when CRC Watch is on, even if there are no errors. If there are errors, the display will flash more frequently.

CRC readouts. A readout block appears on the right side of the display. The CRC readouts indicate the following conditions:

- **ERRORED SECONDS.** CRC Watch is turned on.
- **FF CRC: <n>.** Displays the seconds that were found to contain one or more full-field CRC errors. A full-field CRC error detected in a one-second interval causes the number to increment by one.
- **FF CRC MISSING.** Either there is no digital video lock, there is no EDH packet in the signal, or there is no CRC signal inserted in the signal.
- **AP CRC: <n>.** Displays the seconds that were found to contain one or more active-picture CRC errors. An active-picture CRC error detected in a one-second interval causes the number to increment by one.
- **AP CRC MISSING.** Either there is no digital video lock, there is no EDH packet in the signal, or there is no CRC signal inserted in the signal.
- **ELAPSED <hh>H:<mm>M.** Displays the hours and minutes that have elapsed since CRC Watch was turned on. The display is in hours (H) and minutes (M). For example, after 3 hours and 24 minutes, the display would read 3H:24M. The elapsed time can accrue up to 99 hours and 59 minutes.

Display

The LCD will retain an image if the instrument is left on in one display mode for an extended period of time. This is typical for the LCD display device. The retained image will fade over time, and the fading can be accelerated by leaving the instrument turned off.



CAUTION. *To prevent image retention in the LCD display, enable the backlight time-out mode or turn the instrument off if the monitor will be left alone for more than two hours.*

EDH Report

EDH (Error Detection and Handling) detects CRC errors. When EDH reporting is on, and an appropriate digital signal is applied, the WFM90D or WFM91D reports EDH status in the upper-right corner of the display. You can turn the EDH report on and off through any of the digital operating menus except Audio.

The EDH messages indicate the following conditions:

- NO EDH. The signal does not contain an EDH packet.
- EDH CHK. EDH ancillary data packet checksum error. Detects corruption of data in ancillary data packet.
- AP CRC ER. An active-picture CRC error has occurred. An AP CRC error also indicates a FF CRC error.
- FF CRC ER. A full-field CRC error has occurred.
- No readout. The EDH packet is present and no checksum or CRC errors are occurring.

NOTE. You can use the Tektronix VM700T Video Measurement Set with Option 1S for analysis of ancillary data and CRC errors.

Refer to SMPTE 291M for information about ancillary data and SMPTE RP165 for information about CRC errors.

Input/Output

The WFM90D and WFM91D can display signals from the one channel of composite video input, one channel of 525 or 625 SDI digital video, or one channel of audio input.

The supported video standards are:

- WFM90D
analog: NTSC composite video
digital: 525 line component 270 Mbit/sec serial digital video (SDI)
- WFM91D
analog: PAL composite video
digital: 625 line component 270 Mbit/sec serial digital video (SDI)

You can switch the input control through the INPUT CTL category of the Configuration menu: select AUTO, DIGITAL, or ANALOG.

- When the input control is set to ANALOG, the WFM90D or WFM91D operates like an analog only monitor.
- When the input control is set to AUTO, the WFM90D or WFM91D operates in either analog or digital mode, depending on the input signal.
- When the input control is set to DIGITAL, the WFM90D or WFM91D is always in digital mode. You may want to use the digital setting if you will be frequently connecting and disconnecting the video signal, so that the monitor does not switch back and forth between modes when the signal is missing.

An external reference input allows you to use an external sync signal. You can set the monitor for internal or internal reference through the INPUT category of the Configuration menu.

The video input and the external reference inputs are BNC connectors. Both inputs have a rear-panel switch providing the choice of an internal 75 Ω signal termination or an unterminated high-impedance input. The audio input is a standard 3-pin XLR connector.

The video output is a BNC connector that will drive a remote monitor or video switcher. The audio output is a mini-headphone stereo jack which outputs the mono input signal to both stereo channels. The audio volume is fixed for each reference level. The larger the displayed signal, the louder the volume.

Line Select Mode

In Line Select mode, you can select any line of video for viewing in either the Waveform or Vector display modes. The desired line can be selected from either all video fields or from alternating fields. With two-field sweep selected in the Waveform display mode, the selected line is highlighted in the field display.

Picture Display Mode

The Picture display mode provides an unprocessed full color display of the composite video signal. The NTSC Safe Action and Safe Title areas, as well as the PAL Safe Area can be highlighted. You can view the vertical interval portion of the signal by vertically shifting the display. You can adjust the hue and color of the picture display.

Preset Menu

You can use the Preset menu to store the current instrument front-panel and menu settings for future use. In addition, there is a menu selection that sets the front panel and menu settings back to a factory-set default. These default settings are listed in Table 2-8 on page 2-36.

Time-Out Mode

When this mode is enabled, the backlight and/or the instrument will shut down after there has been no keypad activity for a menu-selected length of time. The instrument power shutdown is only functional when the instrument is battery powered.

You can use this mode to reduce battery power usage while the instrument is battery powered, and also to extend the life of the backlight bulb. To enable the Time-out mode, use the Configuration menu.

Backlight Time-Out

When the backlight has been timed out, the LCD display goes blank and the instrument appears to be off. The backlight turns back on when you press any keypad button other than the ON button.

Instrument Power Time-Out

When the instrument power has timed out, you must press the ON button to turn the instrument back on.

Variable Gain Mode

The Variable Gain mode allows the user to vary signal gain for the Waveform and Vector displays between 45% and 155%. The mode is enabled through a menu selection in the Configuration menu.

The variable gain adjustment tracks between the Waveform and Vector display modes, and can be adjusted from the Waveform-in-Picture display mode. When the Variable Gain mode is enabled, the message GAIN UNCAL is displayed in the onscreen readout.

Vector Display Mode

The Vector display mode presents an XY plot of the demodulated chrominance phase and amplitude portion of the video signal. The vector angle represents chrominance phase, and the distance from the center represents chrominance amplitude. The vector display is useful when making differential gain and phase measurements.

Gain

A full 360° phase shifter, and 75% and 100% color bar settings are provided. Vector gain is fixed at X1 or X5, or variable from 45% to 155%. The gain setting tracks between the Waveform and Vector display modes. The +V mode (PAL only) overlays the -V axis on the +V axis to check the PAL system color encoders.

Video Input Control

You can view an analog or digital signal (see *Input/Output* on page 2-16 for signal types and input control).

Viewing Serial Digital Signals

When viewing digital signals, you can open the digital Vector menu (shown in Figure 2-4 on page 2-23) and turn on the EDH reporting and CRC Watch.

NOTE. *The digital signal is encoded into analog and is displayed as an analog vector signal with burst. Align the burst vector on the burst vector graticule targets (see Figure 3-3 on page 3-4 and Figure 3-4 on page 3-5).*

You can turn setup on (see SETUP CTL in the *Configuration Menu*, page 2-32, or see page 2-46 of the *Tutorial*).

Waveform Display Mode

The Waveform display mode provides a voltage-versus-time display of the video signal with three standard sweep rates: 1H ($5\ \mu\text{s}/\text{division}$), 2H ($10\ \mu\text{s}/\text{division}$), and 2F (two field). Each line-rate sweep can be magnified X10 to sweep rates: 1H Mag ($0.5\ \mu\text{s}/\text{division}$), and 2H Mag ($1\ \mu\text{s}/\text{division}$). The 2F sweep is magnified by approximately X20.

Vertical gain is fixed at X1 or X5, or variable from 45% to 155%. The gain setting tracks between the Waveform and Vector display modes. The signal filters are Flat (no filter) and Luminance (low-pass filtered). The Line Select mode enables the selection of a single line of video for display.

Video Input Control

You can view an analog or digital signal (see *Input/Output* on page 2-16 for signal types and input control).

Viewing Serial Digital Signals

When viewing a digital signal, you can open the digital Waveform menu (shown in Figure 2-4 on page 2-23) and select a component of the waveform for display. The name of the selected component (such as GREEN or PB) appears in the upper left corner of the display.

You can also select a composite display, which is the digital signal converted to analog. This composite display has burst and sync.

NOTE. *Sync seen on the Y component is a result of the conversion process for displaying digital signals on this monitor.*

Waveform-in-Picture Display Mode

The Waveform-in-Picture (WIP-screen) display mode provides a 1/4-screen-sized window over the Picture display for any one of the Waveform, Vector, or Audio displays. The WIP window can be positioned to any one of the four corners of the display. The Arrow Buttons retain their default function for the display mode in the WIP window.

Video Input Control

You can view an analog or digital signal (see *Input/Output* on page 2-16 for signal types and input control).

Viewing Serial Digital Signals

When viewing a digital signal, you can open the digital WIF menu (shown in Figure 2-5 on page 2-24) and turn the EDH reporting and CRC Watch on and off.

Using the Menus

This section describes the operating and configuration menus for the WFM90D and WFM91D.

Figure 2-4 and Figure 2-5 show the complete menu structure for all of the operating menus. Figure 2-7 (on page 2-32) shows the menu structure for the Configuration menu.

Some menu selections appear only in one or the other model, or only in digital mode. These special considerations are noted in the following illustrations and tables.

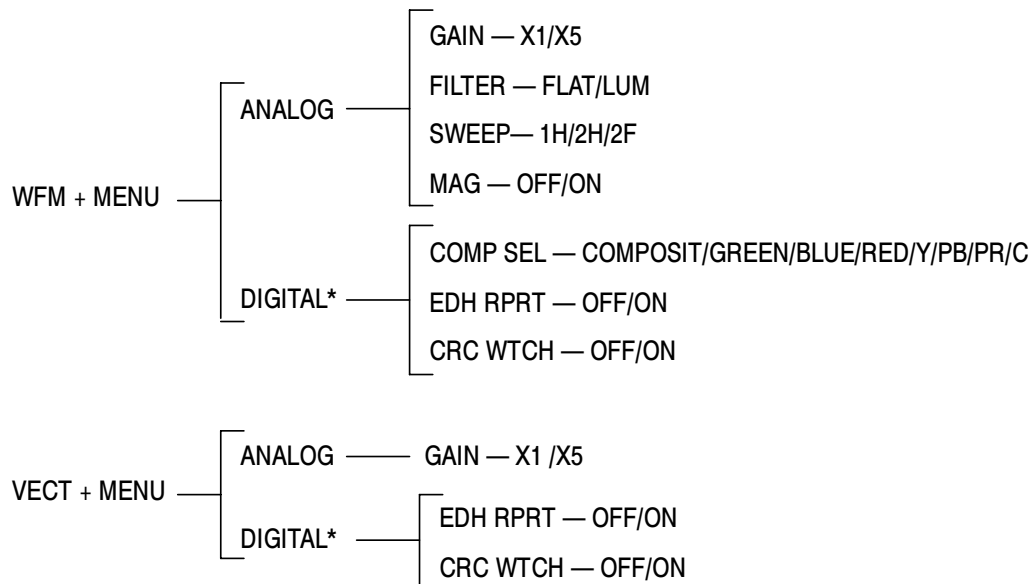

*Hold MENU button two seconds for digital menu

Figure 2-4: Waveform and Vector menus

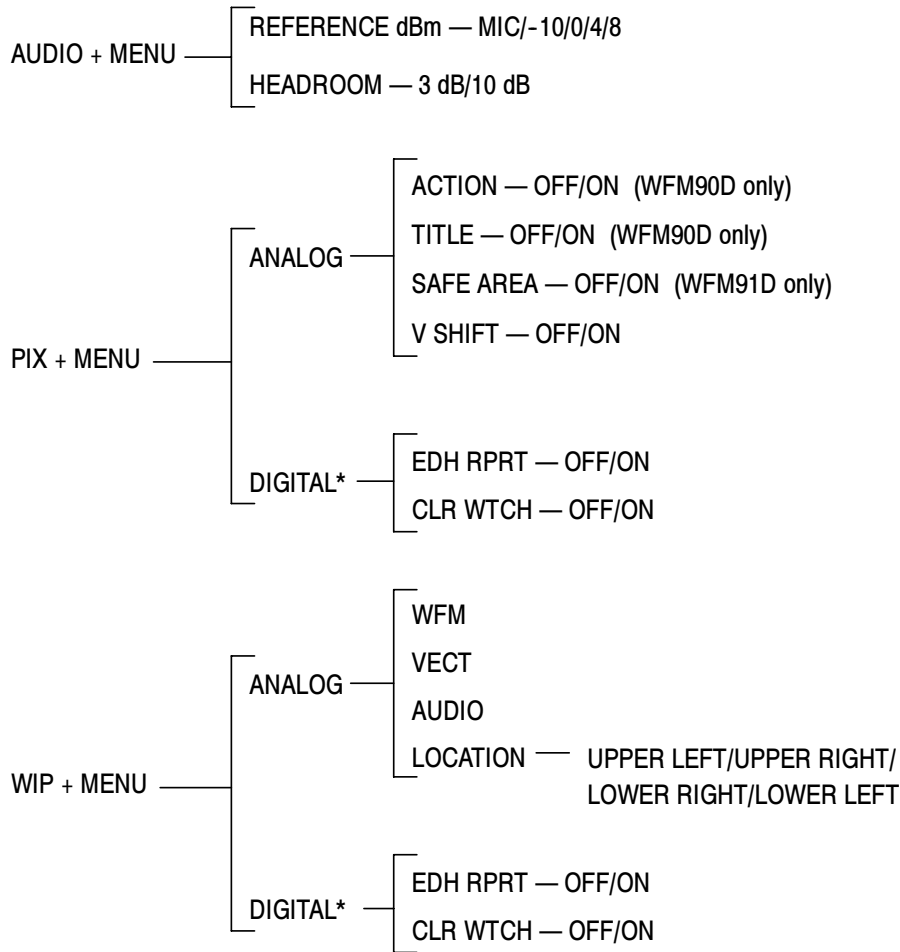

*Hold MENU button two seconds for digital menu

Figure 2-5: Audio, Picture, and Waveform-in-Picture menus

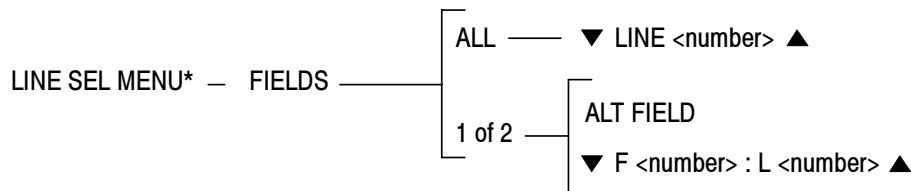

*Line Select menu appears only in WFM + VECT modes

Figure 2-6: Line Select menu

Operating Menus

The following pages describe the operating menus, shown in Figure 2-4 and Figure 2-5.

Each operating mode has an associated menu. In addition, the Waveform, Vector, Picture, and WIP operating modes have an associated digital menu.

Operating menu selections affect only the display mode in which they appear (unless otherwise noted). If you switch to a different operating mode, the menu for the new mode will display.

Accessing Menus

To enter an operating menu, select the desired operating mode (such as Waveform or Audio), and then press the MENU button.

To exit, press the MENU button again.

Accessing Digital Menus

To enter a digital operating menu, first ensure that the input control is configured for AUTO or DIGITAL (see *Configuration Menu* on page 2-31). Then select the desired operating mode (Waveform, Vector, Picture, or WIP) and hold the MENU button for 2 seconds.

To exit, press the MENU button again.

Using the Menus

Press the bezel button that corresponds to the desired selection on the display. When you make a selection, changes are displayed immediately.

To adjust values, press the two right bezel buttons while displaying a menu selection such as ▼ TRACE ADJUST ▲ .

Waveform Menu

Press the WFM button and the MENU button to open the Waveform operating menu. Hold the MENU button in for two seconds to open the digital menu. For more details on menu access, see page 2-25.

Waveform menu choices are shown in Table 2-2. The Waveform menu tree is shown in Figure 2-4.

Table 2-2: Waveform menu choices, analog and digital

Submenu	Digital only	Function
GAIN		Sets the Waveform display mode vertical gain and the Vector display mode gain to X1 or X5.
FILTER		Selects FLAT (unfiltered display) or LUM (low-pass filtered for luminance display).
SWEEP		Selects sweep rate: 1H (5 μ s/division), 2H (10 μ s/division), or 2F (two field).
MAG		Turns horizontal gain on or off. When set to on, additional sweep rates are available: 1H + MAG (0.5 ms/division), 2H + MAG (1 ms/division), and 2F + MAG (magnified by approximately X20).
COMP SEL	✓	Selects a component of the signal for display. You can also display a composite signal (the digital input signal is converted to analog).
EDH RPRT	✓	Enables or disables the EDH reporting readout at the top center of the display in Waveform and Vector modes.
CRC WTCH	✓	Enables or disables the CRC reporting readout on the right side of the display in Waveform and Vector modes.

Vector Menu

Press the VECT button and the MENU button to open the Vector operating menu. Hold the MENU button in for two seconds to open the digital menu. For more details on menu access, see page 2-25.

Vector menu choices are shown in Table 2-3. The Vector menu tree is shown in Figure 2-4.

Table 2-3: Vector menu choices, analog and digital

Submenu	Digital only	Function
GAIN		Sets the Vector display mode gain and the Waveform display mode vertical gain to X1 or X5.
EDH RPRT	✓	Enable or disable the EDH reporting readout at the top center of the display in Waveform and Vector modes.
CRC WTCH	✓	CRC Watch. Enable or disable the CRC reporting readout on the right side of the display in Waveform and Vector modes.

Audio Menu

Press the AUDIO button and the MENU button to open the Audio operating menu. There is no digital menu for audio. For more details on menu access, see page 2-25.

Audio menu choices are shown in Table 2-3. The Audio menu tree is shown in Figure 2-5.

Table 2-4: Audio menu choices

Submenu	Function
REFERENCE dBu	Sets the Audio reference level to MIC, -10, 0, 4, or 8. The reference levels are measured in dBu, and the MIC level is for testing microphones.
HEADROOM	Sets the headroom reference level to -3 dB or +10 dB. Use the +10 dB setting for viewing signal levels greater than 3 dB over the reference level.

Picture Menu

Press the PIX button and the MENU button to open the Picture operating menu. Hold the MENU button in for two seconds to open the digital menu. For more details on menu access, see page 2-25.

Picture menu choices are shown in Table 2-5. The Picture menu tree is shown in Figure 2-5.

Table 2- 5: Picture menu choices, analog and digital

Submenu	Digital only	Function
ACTION		WFM90D only. Turns the Safe Action area markers on and off.
TITLE		WFM90D only. Turns the Safe Title area markers on and off.
SAFE AREA		WFM91D only. Turns the Safe Area markers on and off.
V SHIFT		Turns the vertical shift on and off. The vertical shift allows you to view the vertical interval on the Picture display. The vertical interval display does not appear on the VIDEO OUT signal.
EDH RPRT	✓	Enable or disable the EDH reporting readout at the top center of the display in Waveform and Vector modes.
CRC WTCH	✓	CRC Watch. Enable or disable the CRC reporting readout on the right side of the display in Waveform and Vector modes.

WIP Menu (Waveform-in-Picture)

Press the WIP button and the MENU button to open the Waveform-in-Picture operating menu. Hold the MENU button in for two seconds to open the digital menu. For more details on menu access, see page 2-25.

WIP menu choices are shown in Table 2-5. The WIP menu tree is shown in Figure 2-5.

Table 2-6: WIP menu choices, analog and digital

Submenu	Digital only	Function
WFM		Selects the Waveform mode for display in the WIP window.
VECT		Selects the Vector mode for display in the WIP window.
AUDIO		Selects the Audio mode for display in the WIP window.
LOCATION		Selects the position of the WIP window in the Picture display (selects from the four corners of the screen).
EDH RPRT	✓	Enable or disable the EDH reporting readout at the top center of the display in Waveform and Vector modes.
CRC WTCH	✓	CRC Watch. Enable or disable the CRC reporting readout on the right side of the display in Waveform and Vector modes.

Configuration Menu

The following pages describe the instrument configuration menu, shown in Figure 2-7 on page 2-32. Menu categories and functions are described in Table 2-7 on page 2-33.

Configure Menu Access

To enter the Configuration menu, press the CONFIG button.

To exit the configuration menu, press the CONFIG button again.

Using the Menu

Press the bezel button that corresponds to the desired selection on the display. When you make a selection, changes are displayed immediately.

Configuration menu categories are displayed above the left bezel button. The selected category is highlighted. To scroll through the menu categories, press the left bezel button or press the ▲ and ▼ buttons.

Menu selections within the selected category appear over the right three Bezel Buttons.

To adjust values, press the two right bezel buttons while displaying a menu selection such as ▼ TRACE ADJUST▲ .

NOTE. *If you adjust picture hue and/or color, the only way to ensure that the hue and color have been correctly reset is to recall the factory default settings through Configuration PRESETS.*

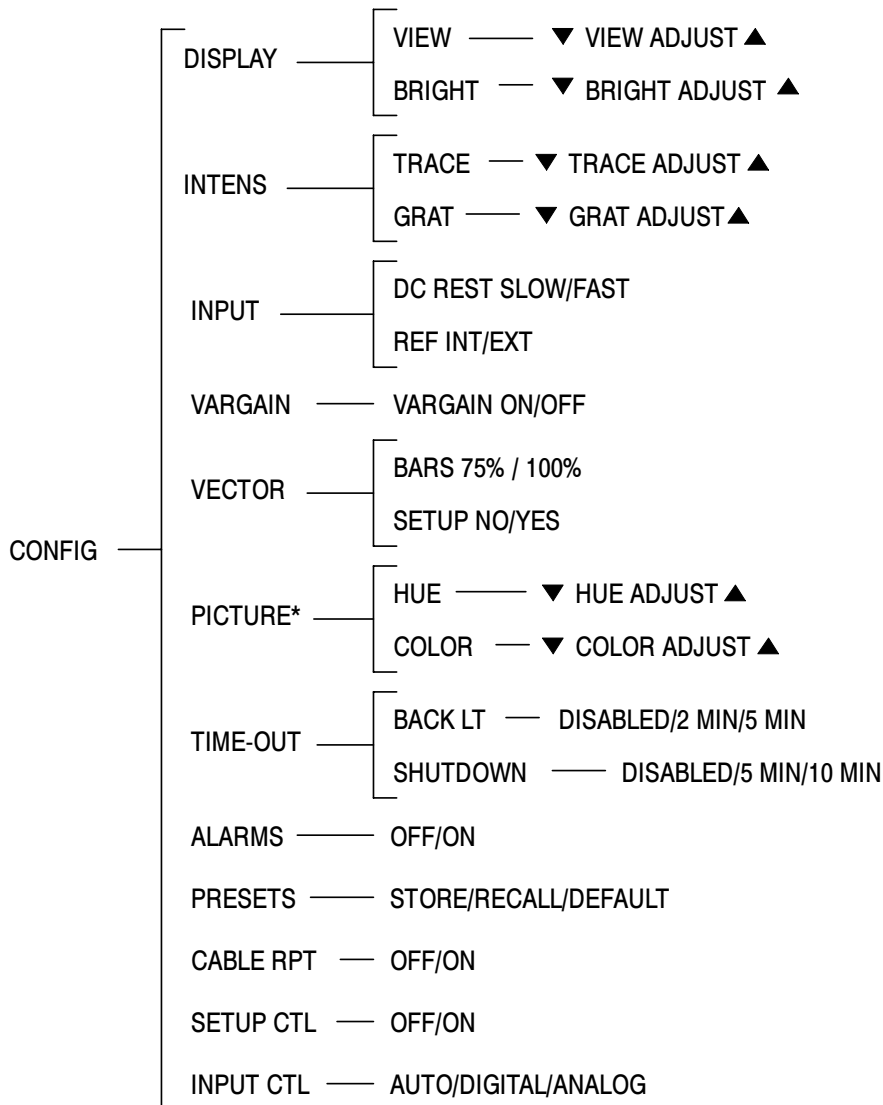

*Must be in PIX mode to adjust

Figure 2-7: Configuration menu

Table 2-7: Configure menu choices

Category	Submenu	Function
DISPLAY	VIEW	The right two bezel buttons adjust the viewing angle of the LCD display up or down to allow optional viewing of the display from different positions.
	BRIGHT	The right two bezel buttons adjust the brightness of the LCD display.
INTENS	TRACE	The right two bezel buttons adjust the intensity of the signal trace.
	GRAT	The right two bezel buttons adjust the intensity of the measurement graticule.
INPUT	DC REST	Sets the DC restorer speed to SLOW or FAST.
	REF	Sets the video signal reference to INT (internal reference) or EXT (external reference input signal). When external reference is selected, EXT REF appears in the onscreen readout of the Waveform and Vector displays. If the monitor loses its signal reference, MISSING SYNC is displayed in the onscreen readout.
VAR GAIN	VAR GAIN	<p>Turns the variable gain on and off. When the variable gain is on, the right two bezel buttons adjust the signal gain (the instrument must be in Waveform or Vector display mode). The first time you press one of the right two bezel buttons, the category list disappears from the left side of the display to provide maximum signal viewing. The right two bezel buttons will now adjust the signal gain. To see the category list, press the left bezel button.</p> <p>When the variable gain is on, GAIN UNCAL displays onscreen in Waveform, Vector, and Waveform-in-Picture display modes.</p>

Table 2-7: Configure menu choices (continued)

Category	Submenu	Function
VECTOR	BARS	Sets the calibration of the vector chrominance gain to correctly process 75% or 100% amplitude color bar signals.
	SETUP	<i>(WFM90D only)</i> Sets the vector gain to correctly process NTSC input signals with or without setup.
	ALT PH	<i>(WFM91D only)</i> Alternate Phase. Turns the PAL +V mode on and off. When the mode is on, the phase reference of the -V lines is inverted and then shown as an overlay on the +V lines to provide a comparison display.
PICTURE	HUE	<i>(WFM90D only)</i> When HUE is selected, the right two Bezel Buttons adjust the hue of the Picture display (instrument must be in Picture display mode).
	COLOR	The right two Bezel Buttons adjust the color of the Picture display (instrument must be in Picture display mode).
TIME-OUT	BACK LT	You can set the instrument to shut down power to the backlight after 2 minutes or 5 minutes of inactivity.
	SHUTDOWN	You can set the instrument to power down after 5 minutes or 10 minutes of inactivity. Only functional when the instrument is battery powered.
ALARMS		Turns the alarm on and off for the Waveform and Vector display modes.
PRESETS	STORE	Stores the current keypad and menu settings in memory for future recall.
	RECALL	Resets the keypad and menu settings to the last settings that were stored in memory.

Table 2-7: Configure menu choices (continued)

Category	Submenu	Function
PRESETS	DEFAULT	Resets the front panel and menu settings to their factory-set defaults. Monitoring adjustments such as signal position, vector phase, and picture hue are also reset. The default settings of the keypad and menus are listed in Table 2-8.
CABLE RPT		(Digital only) Turns the cable report off and on. When cable report is turned on, the message >Cable appears if the cable length is greater than 200 meters. There is no message if the cable is equal to or less than 200 meters.
SETUP CTL		<i>(WFM90D only; has no effect on the WFM91D)</i> Turns the setup on or off for digital signals. When setup is on, 7.5 IRE of setup is applied to the composite display of the input signal.
INPUT CTL		Specifies the type of input signal the instrument will receive. With ANALOG selected, the monitor operates like an analog-only monitor. With AUTO selected, the instrument automatically switches between analog and digital modes based on the input signal. With DIGITAL selected, the instrument is always in digital mode. You might want to use this setting if you will frequently connect and disconnect the input signal, so that the instrument doesn't switch into analog mode when no signal is detected.

Table 2-8: Default instrument settings

Parameter	Default setting
Signal reference	Internal
Filter	Flat
DC restorer speed	Slow
Gain	X1
Variable gain	Off
Sweep	2H (2 Line)
Mag	Off
Bars	75%
Setup (<i>WFM90D only</i>)	Yes
Alt Phase (<i>WFM91D only</i>)	Off
Reference dBu	0 dBu
Headroom	3 dB
WIP location	Bottom right
Alarms	Off
Safe action	Off
Safe title	Off
Vertical shift	Off
Backlight time-out	Disabled
Instrument time-out	Disabled
Cable report	On
Setup control (<i>WFM90D function only</i>)	On
Input control	Auto
EDH report	On
CRC watch	Off

Line Select Menu

The instrument must be in the Waveform, Vector, or WIP operating mode before you can display the Line Select menu.

Enter the Waveform, Vector, or WIP operating mode. Press the LINE SEL button to turn on Line Select mode and open the Line Select menu. The number of the selected line and/or field displays in the menu bar over the right two Bezel Buttons.

The Line Select menu is shown in Figure 2-6 on page 2-24 and the Line Select menu choices are shown in Table 2-9. For more information about Line Select, refer to *Line Select Mode* on page 2-17.

Table 2-9: Line Select menu choices

Selection	Function
FIELDS ALL	Selects all video fields for display. The two right bezel buttons select which line number is displayed. The menu bar over these two buttons displays the selected line number.
FIELDS 1 OF 2	When 1 OF 2 is selected, the menu selection ALT FIELD appears. This allows you to select the video field in which the selected line is displayed.

Tutorial

You can use the procedures in this section to learn and/or check basic instrument operation. If you discover improper instrument operation, check the operation of associated equipment. If the associated equipment is operating normally, refer the WFM90D or WFM91D to qualified service personnel for repair or adjustment.

For more information about any of the functions described here, check *Operating Information*, starting on page 2-11, or the *Index* at the back of the manual.

Required Equipment

The following equipment is required to perform this procedure:

- Television/Audio Signal source with:

- NTSC/PAL Composite Color Bars (analog)
- Black Burst or comparable signal with burst and sync
- SDI 525/625 signal (digital)
- Audio tone at adjustable levels

For example:

Tektronix TSG95 Pathfinder NTSC/PAL Signal Generator for analog signals and a Tektronix TSG601 Handheld Signal Generator for digital signals.

-or-

Tektronix TG2000 Test Signal Generator with an AVG1 module for analog signals and a DVG1 module for digital signals.

-or-

Tektronix TG700 Test Signal Generator with an ATG7 module for analog signals and a DVG7 module for digital signals.

- Coaxial cable, 75 Ω (2)
For example: 42-inch RG59U (Tektronix part no. 012-0159-00)
- Audio Cable, 3-pin Male-to-Female XLR
For example: 3-foot cable (Switchcraft part no. SC3XXJ)

Initial Equipment Connections

- Connect power to the WFM90D or WFM91D by plugging in the AC power adapter or by installing batteries.
- Connect a 75% color bar signal (with setup for NTSC) of the correct standard for your instrument from the analog television signal source to the VIDEO IN connector. Verify that the VIDEO IN input switch is set to the 75 Ω position.
- Connect a black burst or other signal with burst and sync from the analog television signal source to the EXT REF connector on the WFM90D or WFM91D. Verify that the EXT REF input switch is set to the 75 Ω position.

Procedure

Restoring Factory Default Settings

1. Press the CONFIG button to open the Configuration menu.
2. Press the bezel button below the Configuration menu category list a few times to select different menu categories. The selected menu category is highlighted. Corresponding menu selections appear to the right.
3. Press the ▲ and ▼ buttons and notice that they also select menu categories.
4. Select the PRESETS category, and then press the right bezel button to select DEFAULT. The front-panel controls and menu selections are now set to the factory-set defaults. The display should be a two-line waveform monitor display centered on the graticule baseline.

Adjusting the Display

5. Enter the Configuration menu again.
6. Select the INTENS category.
7. Use the appropriate bezel button to select TRACE. Now the two right bezel buttons are assigned to adjust the trace intensity. Adjust the display to the desired intensity.
8. Select GRAT and adjust the graticule intensity to the desired level.
9. Select the DISPLAY category.
10. Select VIEW. Press the right two bezel buttons to adjust the viewing angle of the LCD display to the desired angle.
11. Select BRIGHT and adjust the display brightness to the desired level.
12. Press the CONFIG button to exit the menu.

Using the Waveform Monitor

13. Press the WFM button to enter the waveform mode.
14. Press the MENU button to enter the waveform operating menu.
15. The current selection for each monitoring function is highlighted. Press the bezel buttons below the functions and notice that the highlight bar moves, indicating different menu selections.
16. Select X1/X5 gain:
 - a. Press the left bezel button and notice that X5 is highlighted and that the waveform is vertically amplified. Use the ▲ and ▼ buttons to view the entire signal.
 - b. Select X1 and return the signal to the graticule baseline. The gain setting affects both the Waveform and Vector displays since they track together.

17. Select filter type:

- a.** Press the bezel button below the FILTER selection and notice that LUM is highlighted; the display changes to show only the luminance portion of the signal.
- b.** Press the bezel button again to return the filter selection to FLAT.

18. Select sweep setting:

- a.** Press the bezel button below the SWEEP selection and highlight 2F; the waveform changes to a two-field display.
- b.** Press the bezel button again to select 1H; the waveform changes to a one-line display and $5 \mu\text{S}/\text{DIV}$ displays onscreen. Return the sweep rate to 2H (two line).

19. Turn MAG on and off:

- a.** Press the right bezel button to highlight MAG ON. The waveform is horizontally amplified. The sweep rate readout is $1 \mu\text{S}/\text{DIV}$. Use the ◀ and ▶ buttons to view the entire waveform.
- b.** Select MAG OFF and center the waveform on the display.

20. Display DC restorer settings:

Enter the Configuration menu and select the INPUT category. Notice the DC REST menu selection, which allows you to change the DC restorer speed between FAST and SLOW.

21. Select internal or external reference:

- a.** Press the bezel button below the REF menu selection to select EXT; the EXT REF readout appears onscreen.
- b.** Remove the cable from the EXT REF input and notice that the waveform free-runs; the message MISSING SYNC appears onscreen.
- c.** Return the reference selection to INT.

22. Display a line in Line Select:

- a.** Press the LINE SEL button to enter the Line Select mode. The selected line number (Line 17) is displayed in the bar over the two right bezel buttons and it is being displayed from ALL video fields. Line 17 is displayed on the left, with Line 18 displayed on the right in the two-line sweep.
- b.** Use the bezel buttons to select Line 30 for display.
- c.** Press the MENU button to enter the waveform operating menu and select 2F SWEEP. The selected line is highlighted in both field displays.
- d.** Press the LINE SEL button to return to the Line Select menu. Press the left bezel button to select 1 OF 2 FIELDS. An additional menu selection of ALT FIELD appears; the line number display now includes the field number, and the selected line is now highlighted in only the left field display.
- e.** Press the ALT FIELD bezel button and notice that the field number readout changes and that the highlight bar in the waveform toggles between the two fields.
- f.** Turn off the Line Select mode by pressing the LINE SEL button.

23. Apply variable gain:

- a.** Enter the waveform operating menu and select 2H SWEEP.
- b.** Enter the Configuration menu and select the VAR GAIN category. Select VAR GAIN ON and notice that a bar appears over the right two bezel buttons labeled VAR ADJUST; the message GAIN UNCAL appears onscreen.
- c.** Press one of the right two bezel buttons just one time. The Configuration menu category list over the left bezel button is replaced by the CONFIG label so that you can view the full waveform. The up and down arrows appear in the bar over the two right bezel buttons, signifying that they are assigned to adjust the signal gain. To restore the menu category list, press the left bezel button or turn off the variable gain.

- d. Use the right two bezel buttons to adjust the signal gain to any desired level. Select **VAR GAIN OFF** and notice that the waveform gain is restored to 100%. Select **VAR GAIN ON**; notice that the waveform gain returns to your adjusted setting.
- e. Turn off the variable gain and press the **CONFIG** button to exit the Configuration menu.

24. Turn setup on/off (WFM90D, Digital signal, Composite only):

When viewing a digital signal in composite mode, you can turn setup on and off. When you turn setup on, the monitor will add 7.5 mV of setup to the signal on the composite display.

- a. Provide an SDI 525 signal from the television signal source.
- b. Enter the digital waveform operating menu. Press the bezel button under **COMP SEL** to select **COMPOSIT**. The serial digital input signal is encoded into analog and displayed as a composite signal.
- c. Enter the **CONFIG** menu and select the **SETUP CTL** category. Press the bezel button to turn setup on and off. Notice the 7.5 mV of setup on the signal.
- d. Turn setup back on. From the analog television signal source, provide an NTSC color bar signal with setup.

25. Set the input control for analog, digital, or auto:

- a. Enter the Configuration menu. Select the **INPUT CTL** menu category.
- b. Press the bezel button to select **ANALOG**. The instrument is in analog operating mode and will operate like an analog only monitor.
- c. Press the bezel button and select **DIGITAL**. The instrument is in digital operating mode. This setting keeps the monitor from switching between modes when you connect /disconnect the video signal.
- d. Press the bezel button and return the setting to **AUTO**. Leave the setting at **AUTO** for the remainder of the procedure so that you can switch between analog and serial digital signals.

Digital signal monitoring.

26. Provide an SDI 525/625 signal from the digital television signal source.
27. Select a component for display:
 - a. Press and hold the MENU button for two seconds to enter the digital portion of the waveform operating menu.
 - b. Press the left bezel button to select Y. Only the luminance portion of the signal is displayed, and a “Y” readout appears at the top of the screen.
 - c. Press the bezel button again to select COMPOSIT. Notice that the composite signal is displayed. This is the digital signal, converted to analog.
28. Enable EDH reporting:
 - a. Press the bezel button under the EDH RPRT menu selection to turn the EDH reporting. If your television signal source provides error insertion, insert CRC errors. When EDH errors are present, a readout at the top right of the screen displays the errors. For more information about the readout, see *EDH Report* on page 2-15
 - b. Leave the EDH RPRT selection on or off, as desired.
29. Enable CRC watch:
 - a. Press the bezel button under the CRC WTCH menu selection to turn on the CRC watch. When the selection is on, the readout (near the top right of the screen) displays errored seconds. For more information, see *CRC Watch* on page 2-14.
 - b. Leave the CRC WTCH selection on or off, as desired. (The default is off).
30. Provide a 75% color bar output (NTSC or PAL) from the analog television signal source.

Using the Vectorscope

31. Press the VECT button to enter the Vector display mode.
32. Adjust the vector phase:
 - a. The up and down arrow buttons adjust the vector phase. Press and hold the ▲ button. Notice how fast the phase of the waveform changes. Press and hold the ► button. Notice that the phase changes at a much faster rate. The same is true for the ▼ and ◀ buttons.
 - b. Adjust the burst vector back to the 180° graticule line so that the vector dots land in the target boxes.
33. Select 75% or 100% color bar graticule:
 - a. Select a 100% color bar output from the television signal source. Notice that vector waveform is too large to land in the target boxes.
 - b. Enter the Configuration menu and select the VECTOR category. Select 100% BARS and notice that the vector waveform now lands in the target boxes.
 - c. Select 75% color bars output from the signal source and return the menu setting to 75% BARS.
34. Turn setup on/off (WFM90D only):
 - a. **Analog signal:** Enter the Configuration menu, select the VECTOR category, and then select SETUP NO. This means that the monitor will “expect” a signal without setup. Notice that the vector waveform does not land in the target boxes.

Provide an NTSC color bar signal without setup from the signal source and notice that the vector dots again land in the target boxes. Select SETUP YES and set the signal source for a 75% color bar output with setup.

- b. Digital signal:** Provide an SDI 525 signal from the television signal source. Select the SETUP CTL category in the Configuration menu.

Press the bezel button to turn setup on and off. Notice that when you turn setup on, the monitor will automatically compensate for setup.

- c.** Turn setup back on.
- d.** From the analog television signal source, provide an NTSC color bar signal with setup.

35. Alternate Phase (WFM91D only):

- a.** Select the VECTOR category from the Configuration menu.
- b.** Press the bezel button to turn on ALT PH (alternate phase). The vector waveform now has a mirrored image. Adjust the vector phase with the up and down arrow buttons and notice that the mirrored vectors can be overlaid.
- c.** Turn off the ALT PH and return the burst vector to the 180° graticule line.

Digital Vector operating menu.

- 36.** Provide an SDI 525/625 signal from the digital television signal source.

- 37.** Press and hold the MENU button in for two seconds to enter the digital Vector operating menu.

Notice that you can turn the EDH reporting and CRC watch on and off in this menu. These functions provide the same readouts as in the Waveform mode (see page 2-45).

- 38.** From the analog signal source, return to an NTSC/PAL color bar signal with setup.

Using the Picture Monitor

39. Press the PIX button to enter the Picture display mode. Press the MENU button to enter the Picture operating menu.
40. Adjust picture color:

NOTE. *After you adjust the picture hue and/or color, if you want to ensure that the hue and color are correctly reset, reset the instrument to the factory default settings through the Configuration menu PRESETS category.*

- a. Select PICTURE COLOR and notice that the right two bezel buttons are assigned to adjust the picture color.
 - b. Press the WFM button to enter the Waveform display mode and notice that the bar over the right two bezel buttons now reads ENTER PIX TO ADJ. This message reminds you that the picture color can only be adjusted while in the Picture display mode.
 - c. Return to the Picture display mode and press the right two bezel buttons to adjust the picture color to a desired setting.
 - d. WFM90D only. Select PICTURE HUE and press the right two bezel buttons to adjust the picture hue to a desired setting.
 - e. Select the PRESETS category from the Configuration menu and select DEFAULT to reset the picture hue and color back to their proper settings.
41. Select the Picture display mode. Press the MENU button to enter the Picture operating menu.
 42. WFM90D only. Select ACTION ON and notice that the Safe Action area is outlined on the display. Select TITLE ON and notice that the Safe Title area is now also outlined.

43. WFM91D only. Select SAFE AREA ON.

Notice that the Safe Area is outlined on the display.

Select V SHIFT ON and notice that the display has shifted vertically so that you can see the vertical interval portion of the video signal.

Digital Picture operating menu.**44. Provide an SDI 525/625 signal from the digital television signal source.****45. Press and hold the MENU button in for two seconds to enter the digital Picture operating menu.**

Notice that you can turn the EDH reporting and CRC watch on and off in this menu. These functions provide the same readouts as in the Waveform mode (see page 2-45).

46. From the analog television signal source, provide an analog NTSC/PAL color bar signal with setup.

Using the Waveform-in-Picture (WIP) Display

- 47.** Press the WIP button to enter the Waveform-in-Picture (WIP) display mode.

Notice that the Waveform display is shown in the 1/4-screen-sized window over the Picture display. The Waveform display is shown in the WIP window because it was the last display mode selected.

Notice that the Picture display does not show the Safe Area(s) or the vertical shift, which were left on in the Picture display mode.

- 48.** Press the up and down arrow buttons and notice that they still control signal positioning. You have access to all of the Waveform display controls except those located in the Waveform operating menu. The operating menu selections for any display mode can only be changed while that display mode is selected.

- 49.** Press the right bezel button a few times and notice that the location of the WIP window rotates around the four corners of the Picture display.

Notice that the left three bezel buttons allow you to change which display mode is shown in the WIP window.

Digital WIP operating menu.

- 50.** Provide an SDI 525/625 signal from the television signal source.

- 51.** Press and hold the MENU button in for two seconds to enter the digital WIP operating menu.

Notice that you can turn the EDH reporting and CRC watch on and off in this menu. These functions provide the same readouts as in the Waveform mode (see page 2-45).

- 52.** From the signal source, return to an analog NTSC/PAL color bar signal with setup.

Using the Audio Monitor

53. Connect the output of the audio source to the AUDIO IN connector on the WFM90D or WFM91D.

54. Set the source for a 0 dB tone output.

55. Press the AUDIO button to select the Audio display mode.

Notice that the audio waveform is free-running and that the audio graticule has solid lines labeled 0 dBu representing the reference level and dashed lines labeled -3dB representing the headroom setting.

56. Press the MENU button to enter the Audio operating menu.

- a.** Set the REFERENCE to 4 dBu. Notice that the amplitude of the waveform is reduced and that the graticule line label changed to 4 dBu.
- b.** Set the audio source for a +4 dB output. Notice that the signal amplitude is returned to the reference level graticule line.
- c.** Set the HEADROOM to 10dB. Notice that the graticule scale expands so that the headroom graticule lines are now located outside the reference level graticule lines, and that they are now labeled +10dB. The +10 dB setting allows you to view signals greater than 3 dB over the reference level.

Using the Amplitude Alarm

- 57.** Enter the Configuration menu and select the ALARMS category.
- 58.** Select ON to turn on the Amplitude Alarm mode.
- 59.** Press the MENU button to return to the Audio operating menu.
- 60.** Set the REFERENCE to 0 dBu. Notice that the portion of the audio signal exceeding the reference level graticule lines has been highlighted.
- 61.** Enter the WIP display mode and notice that the alarm highlighting is visible there as well.
- 62.** Select the Waveform display mode to be displayed in the WIP menu.
- 63.** Use the ▲ button to position the waveform above the 100 IRE graticule line. Notice that the portion of the signal exceeding the 100 IRE graticule line is highlighted.

Using the Presets

- 64.** Enter the Configuration menu, select the PRESETS category.
- 65.** Select STORE.
- 66.** Select DEFAULT. Notice that the instrument returned to the Waveform display mode, which is the factory-set default mode.
- 67.** Return to the PRESETS category and select RECALL. Notice that the instrument returns to the WIP display mode with the Waveform display mode displayed and the Amplitude Alarm on, which was the instrument setting when you selected STORE.

Using the Time-Out Mode

- 68.** Select the TIME-OUT category from the Configuration menu.
- 69.** Set the BACK LT to 2 MIN. Wait two minutes and notice that the display goes blank.
- 70.** Press any bezel button and notice that the display returns.
(Pressing any keypad button except the ON button will turn the backlight back on.)
- 71.** The SHUTDOWN menu selections turn off instrument power after the length of time you select (5 MIN or 10 MIN). If you enable timed shutdown, after the instrument times out, press the ON button to turn it back on.

This concludes the tutorial.



Reference

Reference

This section explains how to take measurements with the WFM90D and WFM91D.

Waveform Graticule

There are two versions of the Waveform display mode graticule, illustrated in Figure 3-1 and Figure 3-2:

- NTSC/525 composite video graticule (WFM90D only)
- PAL/625 composite video graticule (WFM91D only)

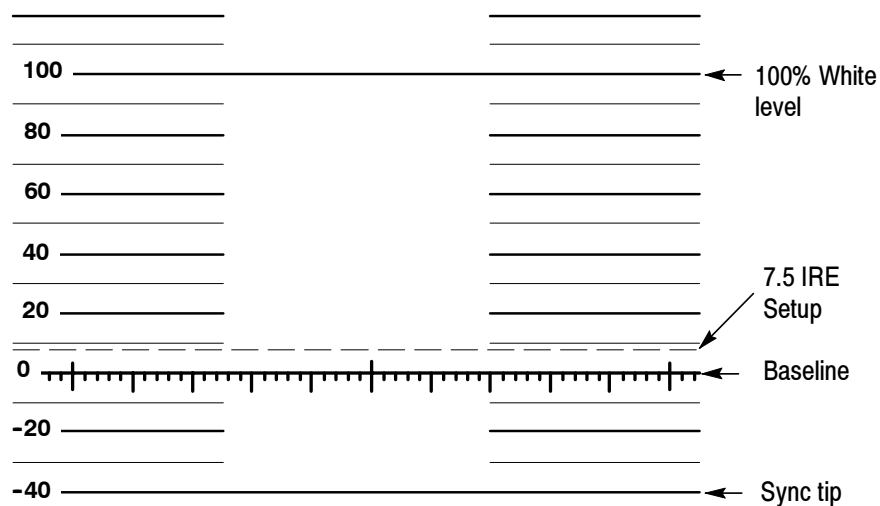

Figure 3-1: NTSC waveform graticule

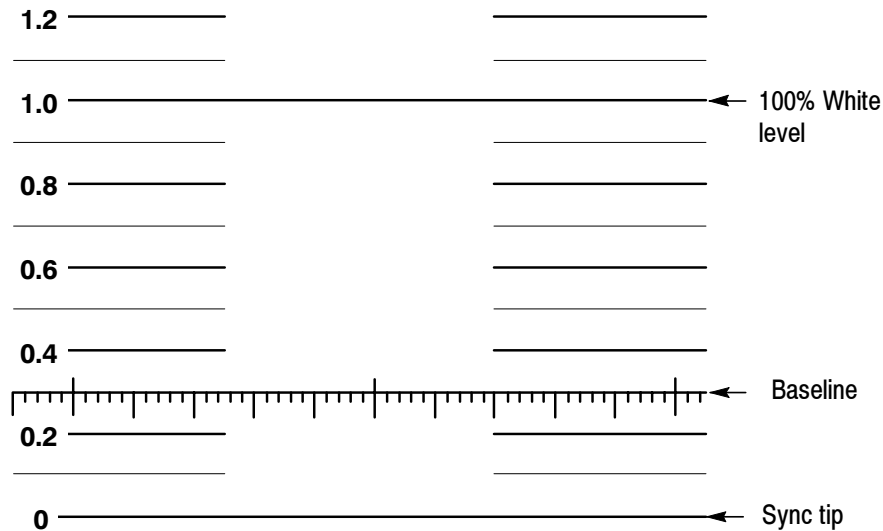

Figure 3-2: PAL waveform graticule

Horizontal Scale

The 0 IRE (0.3 V PAL) graticule line is divided into 12 major divisions. Each division represents a unit of time determined by the SWEEP and MAG settings. Line-sweep rates appear in the onscreen readout, and are as follows:

SWEEP	TIME/DIV	MAG ON
1H (1LINE)	5 μ S/DIV	0.5 μ S/DIV
2H (2LINE)	10 μ S/DIV	1 μ S/DIV

In 2F (two field) sweep with MAG on, the signal is magnified by X20, and the entire vertical interval can be viewed.

Vertical Scales

The NTSC graticule is scaled in IRE units and extends from -40 to +120 IRE, in 10 IRE increments. Black level setup is denoted by a dashed line at 7.5 IRE.

The PAL graticule is scaled in volts and extends from 0 to 1.2 V, in 0.1 V increments.

Making Waveform Measurements

Standard Measurements

You can make standard amplitude and timing measurements of the signal by positioning the waveform on the graticule. The magnification controls aid in measuring small portions of the waveform.

Peak White

With the signal blanking level on the graticule baseline, the amplitude of the 100% white reference of a color bar should be on the 100 IRE (1.0 V PAL) graticule line. The Amplitude Alarm mode highlights any portion of the signal which exceeds the 100 IRE (1.0 V PAL) graticule line.

DC Restorer

Use the SLOW setting for the DC restorer to measure hum or other low-frequency distortions. The FAST setting removes hum from the display so it will not interfere with other measurements. The back porch portion of the input signal is used as the clamping point.

NOTE. When using the shuttle mode on VCRs, set the WFM90D or WFM91D DC restorer speed to SLOW to prevent the loss of signal synchronization.

Digital Video

When the WFM90D or WFM91D input control is set to auto or digital, you can monitor component video (525/625 component 270 Mbit serial digital video). In the Waveform operating mode, you can use the digital Waveform menu to select a component of the signal for display: Green, Blue, or Red; Y, Pb, Pr, or C. You can also select a Composite display, which is the digital signal converted to analog.

You can enable an error detection handling report (EDH RPRT) or cyclic redundancy check (CRC WTCH) to monitor for data transmission errors in the serial video system.

Vector Graticule

The Vector display mode permits measurements of hue in terms of the relative phase of the chrominance signal with respect to the color burst. Relative amplitude of chrominance to burst is expressed in terms of the displacement from center (radial dimension of amplitude).

The two versions of the vector graticule are illustrated in Figure 3-3 and Figure 3-4:

- NTSC composite vector graticule (WFM90D only)
- PAL composite vector graticule (WFM91D only)

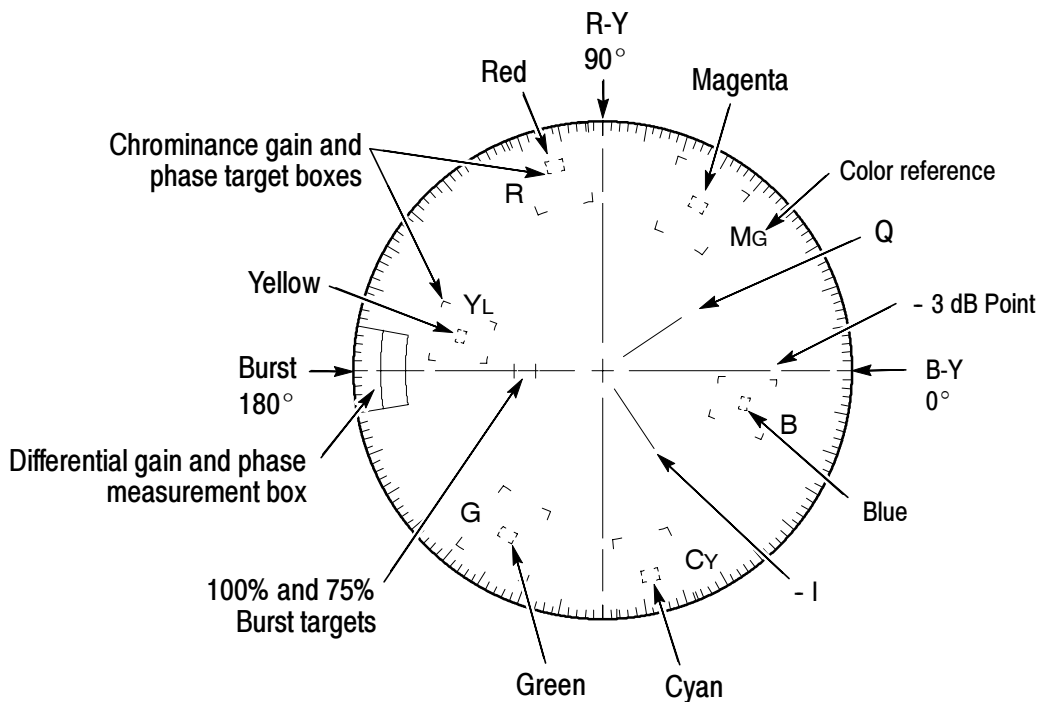

Figure 3-3: NTSC vector graticule

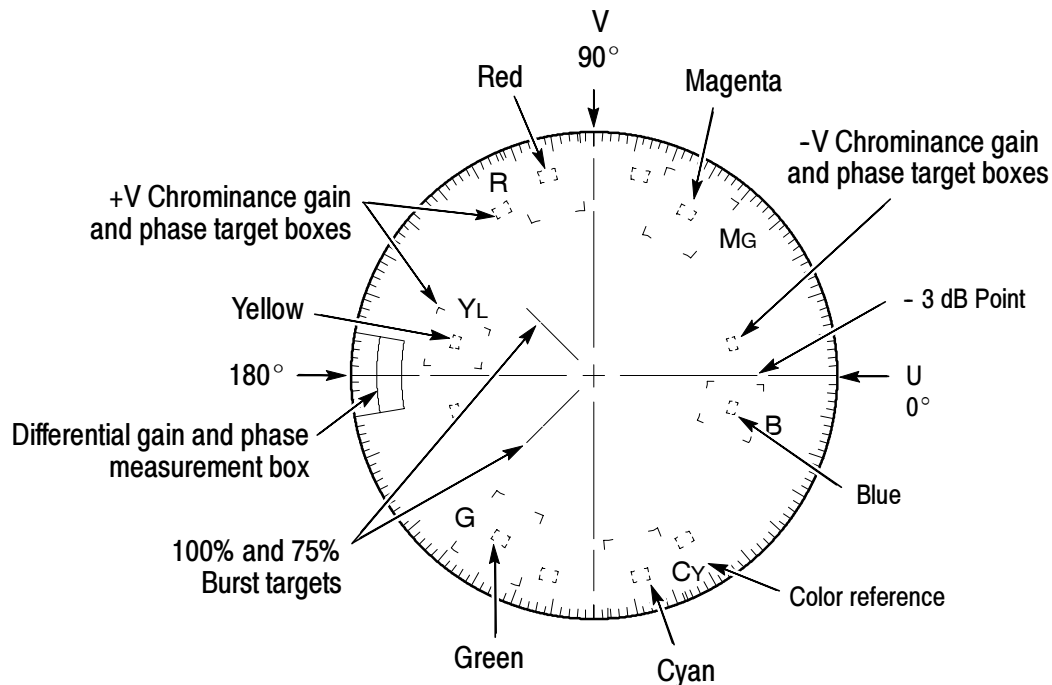

Figure 3-4: PAL vector graticule

Chrominance Vector Targets

The chrominance vectors terminate in a system of graticule targets consisting of two boxes (a small box inside a large box). A sample target is shown in Figure 3-5.

The dimensions of the large boxes represent $\pm 10^\circ$ centered on the exact chrominance phase, and $\pm 20\%$ of chrominance amplitude centered around standard amplitude. The dimensions of the smaller boxes represent $\pm 2.5^\circ$ and ± 2.5 IRE ($\pm 3^\circ$ and $\pm 5\%$ PAL) of chrominance amplitude.

For the PAL graticule, each chrominance vector related to the +V burst terminates in targets consisting of two boxes (a small box inside a large box). The vectors associated with the -V burst terminate in the targets consisting of smaller boxes only.

Differential Phase and Gain Measurement Box

Differential gain (dG) and differential phase (d ϕ) measurements use the graticule markings located at the outer edge of the B-Y or U axis 180° line. See Figure 3-6.

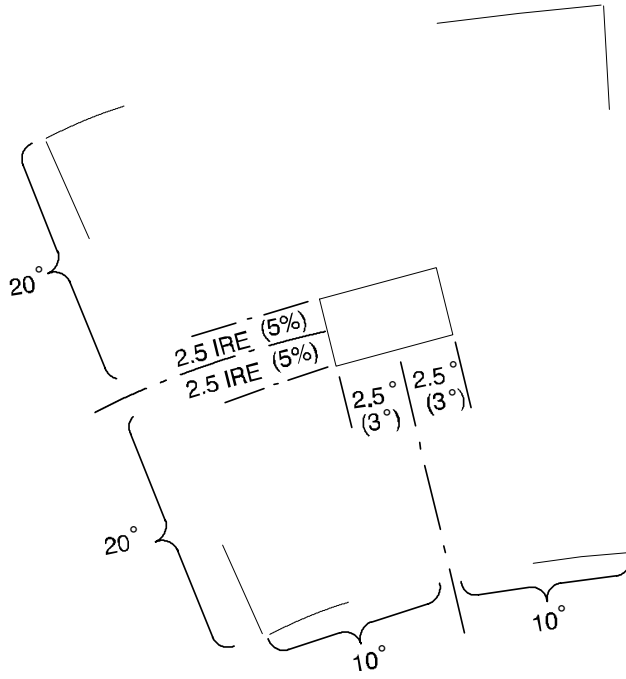

Figure 3-5: Vector targets - NTSC values (PAL values in parentheses)

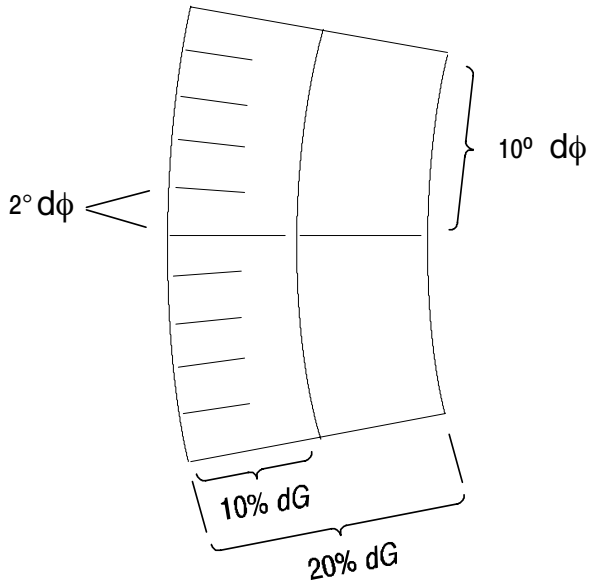

Figure 3-6: Differential gain and phase measurement box

Making Vector Measurements

Chroma Bandwidth

The horizontal and vertical axes of the vector graticule contain markings for checking chroma bandwidth. A subcarrier frequency sine wave (whose amplitude places it on the outer compass rose) is used as a reference. When the frequency is changed, the diameter of the circle should reduce in size. At a point equal to 70.7% of full amplitude (-3 dB), there are gaps in the horizontal and vertical axes. This calibration aid makes it possible to check the -3 dB points of the demodulator output amplifiers.

Digital Video

When the WFM90D or WFM91D input control is set to auto or digital, you can monitor component video (525/625 component 270 Mbit serial digital video).

You can enable an error detection handling report (EDH RPRT) or cyclic redundancy check (CRC WTCH) to monitor for data transmission errors in the serial video system.

NOTE. *The digital signal is encoded into analog and is displayed as an analog vector signal with burst.*

Stress Testing

Unlike analog systems, which tend to degrade gradually, digital systems tend to work without fault until they crash. When operating a digital system, it is desirable to know how much headroom is available (how far the system is from the crash point).

Stress testing consists of changing one or more parameters of the digital signal until failure occurs. The amount of change required to produce a failure is a measure of the headroom.

A good way to stress the system is to add cable until the onset of errors. You can use actual coaxial cable or a cable simulator, however coaxial cable is the most accurate method.

You can use the EDH report or the CRC watch to monitor the occurrence of errors. As an example, using 8281 coax, a 5 meter change in length could go from no errors in one minute to more than one error per second.

Audio Graticule

The audio graticule does not provide a horizontal scale since the signal free-runs at a two-field sweep rate. The vertical scales are composed of the audio reference level and the selected headroom setting, mirrored around the baseline. The audio graticule is illustrated in Figure 3-7 (with -3 dB headroom selected), and in Figure 3-8 (with +10 dB headroom selected).

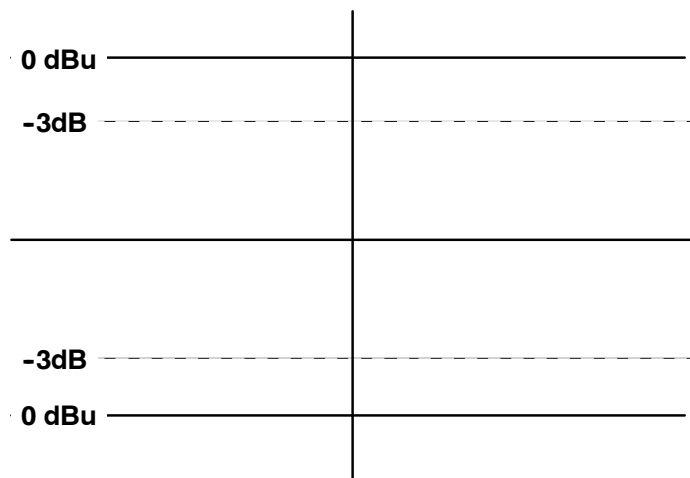

Figure 3-7: Audio graticule with -3 dB headroom selected

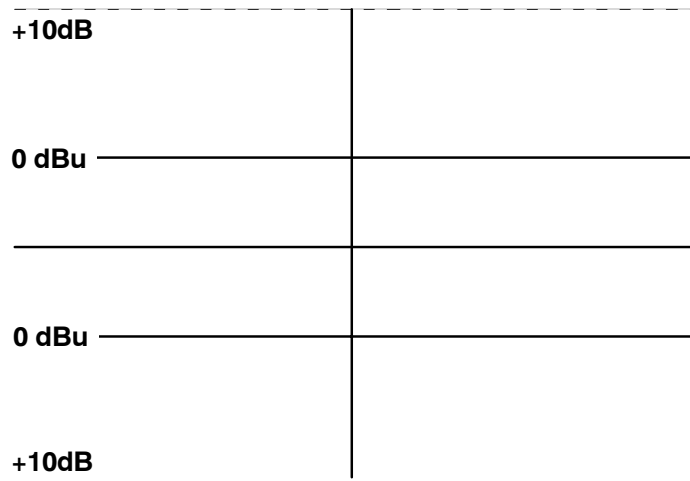

Figure 3-8: Audio graticule with +10 dB headroom selected

Making Audio Measurements

Basic audio system measurements such as signal amplitude and frequency response can be made using the audio graticule.

Signal Amplitude

Signal amplitude is checked by setting the WFM90D and WFM91D reference level through the Operating menu to match your system requirements. The amplitude of the signal display should reach the reference level graticule line during normal operation. The +10 dB headroom setting allows the system amplitude limits to be checked. The amplifier limits are reached when the signal becomes clipped, which is displayed as a squaring off of the signal peaks.

Frequency Response

Signal frequency response is checked by inputting a known signal frequency into the system and verifying that the signal amplitude does not drop below system requirements, usually accepted at -3 dB.

Headroom

The -3 dB headroom setting is used during system setup to verify frequency response of the audio system. The +10 dB headroom setting provides viewing of audio signals 3 dB above the system reference level so that any amplifier clipping can be viewed.



Appendices

Appendix A: Specifications

These tables use the following abbreviations:

Performance Requirement (Req). All performance requirements in the specification tables are identified with **Req**, and can be assured by completing the Performance Check Procedure located in the service manual.

Allow a warm-up time of 20 minutes.

Performance requirements in the electrical specifications are valid over an ambient temperature range of +20 °C to +30 °C. The Performance Requirement tolerances listed in the Electrical Specification are doubled over the temperature range of 0 °C to +40 °C, unless otherwise specified. Test equipment used to verify Performance Requirements must be calibrated and working within the limits specified in the service manual Equipment Required List.

Reference Information. Information that amplifies a performance requirement or is of special importance is indicated by **REF**. There is no need to check these items to a specific tolerance.

Electrical Characteristics

Table A-1. Vertical deflection system

Category	Description
Frequency Response Analog Input	<p><i>REF:</i> Specifications apply for full screen height video input signal, with VARIABLE GAIN off.</p> <p><i>REQ:</i> Flat Filter 1 V Full Scale: 50 kHz to 6 MHz within 2% of response at 50 kHz.</p> <p><i>REQ:</i> Flat Filter X5 Gain: 50 kHz to 6 MHz within 5% of response at 50 kHz.</p> <p><i>REF:</i> Low Pass Filter: ≥ 40 dB attenuation at 3.58 MHz NTSC, 4.43 MHz PAL.</p> <p><i>REF:</i> Response at 15 kHz does not vary between FLAT and LUM (low pass) filters by more than 1%.</p>
Digital Input	<p><i>REF:</i> Specifications apply for full screen height video input signal, with VARIABLE GAIN off.</p> <p><i>REQ:</i> Flat Filter 1 V Full Scale: 50 kHz to 4.5 MHz ± 4%.</p> <p><i>REQ:</i> Flat Filter X5 Gain: 50 kHz to 4.5 MHz ± 5%.</p> <p><i>REF:</i> Low Pass Filter: ≥ 40 dB attenuation at 3.58 MHz NTSC, 4.43 MHz PAL.</p> <p><i>REF:</i> Response at 15 kHz does not vary between FLAT and LUM (low pass) filters by more than 1%.</p>

Table A-1. Vertical deflection system (continued)

Category	Description
Deflection Factor	<p>REQ: Analog Input, 1 V Full Scale: 1 V input displayed within 1% of 140 IRE</p> <p>REF: Flat filter selected.</p> <p>REQ: Digital Input, 1 V Full Scale: 1 V input displayed within 2% of 140 IRE</p> <p>REF: Flat filter selected.</p> <p>REQ: X5 Gain: Gain accuracy within 5% with 1 V input signal.</p> <p>REF: X5 Gain Registration: ≤ 1 major division of vertical shift from baseline between unmagnified and magnified signal.</p> <p>REQ: Variable Gain Range: Input signals between 0.8 V and 2 V can be adjusted to 140 IRE (1.0 V) display. 160 mV to 400 mV for X5 Gain.</p> <p>REQ: Position Range: 1 V signal can be positioned so that peak white and sync tip can be placed at blanking level, with the DC RESTORER on, regardless of gain setting.</p>

Table A-1. Vertical deflection system (continued)

Category	Description
Transient Response Analog Input	<p><i>REF:</i> Specifications apply for full screen height video input signal, with VARIABLE GAIN off, 1 V Full Scale or X5 Gain selected, and FLAT filter selected.</p> <p><i>REF:</i> Pulse-to-Bar Ratio: X1: 0.99:1 to 1.01:1. X5: 0.98:1 to 1.02:1.</p> <p><i>REF:</i> Preshoot: $\leq 1\%$.</p> <p><i>REF:</i> Overshoot: X1: $\leq 2\%$. X5: $\leq 4\%$.</p> <p><i>REF:</i> Ringing: X1: $\leq 2\%$. X5: $\leq 4\%$.</p> <p><i>REF:</i> Field Rate Tilt: $\leq 1\%$.</p> <p><i>REF:</i> Line Rate Tilt: $\leq 1\%$.</p> <p><i>REQ:</i> Overscan: $\leq 2\%$ variation in baseline of 100 IRE (700 mV) 12.5T (20T) modulated pulse as it is positioned over the middle 80% of the screen.</p>

Table A-1. Vertical deflection system (continued)

Category	Description
Transient Response Digital Input	<p>REF: Specifications apply for full screen height video input signal, with VAR GAIN off, 1 V Full Scale or X5 Gain selected, and FLAT filter selected.</p> <p>REF: Pulse-to-Bar Ratio: X1: 0.99:1 to 1.01:1. X5: 0.98:1 to 1.02:1.</p> <p>REF: Preshoot: $\leq 1\%$.</p> <p>REF: Overshoot: X1: $\leq 2\%$. X5: $\leq 4\%$.</p> <p>REF: Ringing: X1: $\leq 2\%$. X5: $\leq 4\%$.</p> <p>REF: Field Rate Tilt: $\leq 1\%$.</p> <p>REF: Line Rate Tilt: $\leq 1\%$.</p>
Maximum Absolute Input Level	<p>REF: ± 5 VDC plus peak AC.</p> <p>REF: Displays in excess of 200 IRE (1.428 V) may cause frequency response aberrations.</p>
DC Input Impedance (Unterminated)	<p>REQ: ≥ 15 kΩ.</p> <p>REF: With input switch in the HIZ position.</p>
Video Input Return Loss	<p>REF: ≥ 40 dB from 50 kHz to 6 MHz ≥ 15 dB from 6 MHz to 270 MHz</p> <p>REF: With 75 Ω termination on.</p>
Video Out Return Loss (75 Ω)	<p>REF: ≥ 30 dB from 50 kHz to 6 MHz.</p>
Video Out Differential Gain (50% APL)	<p>REF: Within 1% with a 140 IRE (1.0 V PAL) unit display. Analog input only.</p>
Video Out Differential Phase (50% APL)	<p>REF: Within 1° with a 140 IRE (1.0 V PAL) unit display. Analog input only.</p>

Table A-2. DC restoration

Category	Description
DC Restorer Clamp Time	<i>REF:</i> Back Porch.
Frequency Response at 60 Hz (50 Hz PAL)	<p><i>REQ:</i> Attenuation of 60 Hz (50 Hz PAL) on Input Signal:</p> <p>Slow Mode: $\leq 20\%$. Fast Mode: $\geq 90\%$.</p> <p><i>REF:</i> Blanking Level Shift with 10% to 90% APL Change: APL changes from 50% to either 10% or 90% will cause blanking level shift of 1 IRE unit (7.14 mV PAL) or less.</p> <p><i>REF:</i> Blanking Level Shift Due to Presence or Absence of Burst: 1 IRE unit (7.14 mV) or less shift from no color burst to presence of color burst.</p>

Table A-3. Audio mode

Category	Description
Reference Levels	<p><i>REQ:</i> -10 dBu, 0 dBu, +4 dBu, +8 dBu.</p> <p><i>REF:</i> Nominal MIC reference: -50 dBu.</p>
Measurement Accuracy	<i>REQ:</i> 0.5 dB at 1 kHz.
Frequency Response	<i>REQ:</i> 0.5 dB from 50 Hz to 20 kHz.
Maximum Input Level Amplitude	<i>REF:</i> +18 dBu.
DC Input Impedance	<i>REF:</i> $\geq 15 \text{ k}\Omega$.
Audio Output Connector	<i>REF:</i> Mini stereo headphone jack.
Maximum Power Output	<i>REF:</i> 250 mW.

Table A-4. Horizontal deflection system

Category	Description
Sweep	<p>REQ: Sweep will occur in all Horizontal mode settings with or without synchronization.</p> <p>REF: Sweep Length: Two Line and Two Field sweep length is nominally 12 divisions.</p>
1LINE Sweep Repetition Rate	REQ: Equal to line-rate of applied video or external sync.
2LINE Sweep Repetition Rate	REQ: Equal to half line-rate of applied video or external sync.
2FLD Sweep Repetition Rate	REF: Displays 2 full fields, including the field-rate sync between them.
2FLD Sweep Magnification	REF: Approximately X20.
Sweep Magnifier Registration	REF: Magnification occurs about the center of the screen.
Timing Accuracy	<p>REF: All timing and linearity specifications exclude the first and last major divisions of the unmagnified display.</p> <p>REQ: 10 μs/division (2LINE): Within 2%.</p> <p>REQ: 5 μs/division (1LINE): Within 2%.</p> <p>REQ: 1 μs/division (2LINE + MAG): Within 2%.</p> <p>REQ: 0.5 μs/division (1LINE + MAG): Within 3%.</p>
Integral Linearity	<p>REQ: Within 1%.</p> <p>REF: Measured between the 10 μs and 110 μs points on the 10 μs/division (2LINE) sweep.</p>
Horizontal Position	REF: Any portion of a synchronized video sweep can be positioned on-screen in all sweep modes.

Table A-5. Vector mode

Category	Description
Chrominance Processing Nominal Subcarrier Frequency (F_{SC})	<i>REF:</i> NTSC: 3.579545 MHz. PAL: 4.43361875 MHz.
Chrominance Processing Chrominance Bandwidth	<i>REQ:</i> Upper -3 dB Point: $F_{SC} + 500$ kHz, ± 100 kHz. Lower -3 dB Point: $F_{SC} - 500$ kHz, ± 100 kHz.
Chrominance Processing +V Mode (Applicable to PAL operation only)	<i>REF:</i> +V-type display as selected by front-panel button. When pushed, V axis is inverted at a 1/2 line rate to produce a single vector display.
Display Vector Phase Accuracy	<i>REF:</i> $\pm 1.25^\circ$. Analog input only. <i>REF:</i> Measured with color bar signal.
Display Vector Gain Stability	<i>REF:</i> Typically $\pm 2.5\%$. Analog input only.
Display Quadrature Phasing	<i>REF:</i> Typically $\pm 0.5^\circ$. Analog input only.
Display Differential Phase	<i>REF:</i> $\pm 1^\circ$. Analog input only. <i>REF:</i> Measured with 140 IRE (1 V) linearity signal (5 step, 10 step, or Ramp) with 40 IRE (300 mV) of subcarrier.
Display Differential Gain	<i>REF:</i> $\pm 1\%$. Analog input only. <i>REF:</i> Measured with 140 IRE (1 V) linearity signal (5 step, 10 step, or Ramp) with 40 IRE (300 mV) of subcarrier.
Subcarrier Regenerator Pull-In Range	<i>REQ:</i> NTSC: ± 50 Hz of F_{SC} . PAL: ± 10 Hz of F_{SC} . <i>REF:</i> Subcarrier Regenerator free-runs in absence of appropriate signal. Reference can be burst of either displayed signal or external reference signal.

Table A-5. Vector mode (continued)

Category	Description
Subcarrier Regenerator Pull-In Time	REF: Pull-In Time: Within 1 second, with subcarrier frequency within 50 Hz (10 Hz for PAL) of F_{SC} .
Subcarrier Regenerator Phase Shift with Subcarrier Frequency Change	REQ: NTSC: $\pm 2^\circ$ from F_{SC} to ($F_{SC} + 50$ Hz), or F_{SC} to ($F_{SC} - 50$ Hz). PAL: $\pm 2^\circ$ from F_{SC} to ($F_{SC} + 10$ Hz), or F_{SC} to ($F_{SC} - 10$ Hz).
Subcarrier Regenerator Phase Shift with Burst Amplitude Change	REQ: $\pm 2^\circ$ from nominal burst amplitude to ± 6 dB. REF: Internal or External burst reference.
Subcarrier Regenerator Phase Shift with Variable Gain Control	REQ: $\pm 1^\circ$ as gain is varied from +3 dB to -6 dB.
Subcarrier Regenerator Phase Control Range	REF: 360° continuous rotation.
Subcarrier Regenerator Burst Jitter	REF: 0.5° RMS or less. REF: With 140 IRE (1 V) composite video input. INT or EXT referenced.

Table A-6. Synchronization

Category	Description
Input Requirements	REQ: Internal Reference Analog Input: Composite video or black burst with sync amplitudes 40 IRE (300 mV PAL) ± 6 dB. Digital Input: 270 Mbit (259M). REQ: External Reference: Sync amplitude between 143 mV and 4 V will synchronize sweeps.

Table A-6. Synchronization (continued)

Category	Description
External Reference Input	<p>REQ: DC Input Impedance (Unterminated): $\geq 15 \text{ k}\Omega$.</p> <p>REF: Return Loss (75Ω): $\geq 40 \text{ dB}$ from 50 kHz to 6 MHz. (With 75Ω termination on, instrument power on.)</p> <p>REF: Absolute Maximum Input Voltage: $\pm 12 \text{ VDC}$ plus peak AC.</p>

Table A-7. Power source

Category	Description
Battery	<p>REF: 6 C-cell batteries or Tektronix NiMH battery pack (Tektronix part number 146-0107-01).</p>
Battery Charge Time (NiMH only)	<p>REF: Fast Charge: 550 mA. REF: Slow Charge: 150 mA.</p>
Power Consumption	<p>REF: Picture Mode: 7 Watts. Waveform Mode 9 Watts. Vector Mode 9 Watts.</p>
External Power	<p>REQ: DC Source of 11 - 18 Volts.</p>

Physical Characteristics

Table A-8. Physical characteristics

Category	Description
Dimensions	<p><i>REF:</i> Instrument: 5 in. (127 mm). 3.15 in. (80.0 mm). 9.6 in. (243.8 mm).</p> <p>Shipping Box: 13.25 in. x 13.75 in. x 6 in. inside 14 in. x 14.25 in. x 6.25 in. outside</p>
Weight	<p><i>REF:</i> With batteries and pouch: 3 lb. 13 oz.</p> <p>Without batteries and pouch: 2 lb. 8 oz.</p> <p>Shipping weight with packaging: 6 lb. 8 oz.</p>

Environmental Characteristics

Table A-9. Environmental characteristics

Category	Description
Operating Altitude	<i>REQ:</i> To 9,842 feet (3000 meters).
Operating Temperature	<i>REQ:</i> 0 °C to +40 °C.
Vibration - Operating	<p><i>REF:</i> 15 minutes each axis at 0.015 inch, frequency varied from 10-55-10 Hz in 1-minute cycles with instrument secured to vibration platform. Ten minutes each axis at any resonant point or at 55 Hz if no resonant point is found.</p>

Table A-9. Environmental characteristics (continued)

Category	Description
Shock - Non-Operating	<i>REF:</i> 100 g's, 1/2 sine, 11 ms duration, 3 shocks per surface (18 total).
Transportation	<i>REF:</i> Qualified under NTSC Test Procedure 1A, Category II (24-inch drop).
Humidity	<i>REF:</i> Will operate at 95% relative humidity for up to five days.

Certification

Table A-10. Certifications and compliances

Category	Standards or description
EC Declaration of Conformity - EMC	Meets the intent of Directive 89/336/EEC for Electromagnetic Compatibility.
	Compliances were demonstrated using EN 61326:1997 EMC Product Family Standard for Electrical Equipment for Measurement, Control, and Laboratory use.
	Emissions ¹ :
	EN 61326 Class A Radiated and Conducted Emissions
	EN 61000-3-2(A14) Conducted Power Line Harmonic Current
	Immunity ^{1,2} :
	IEC 61000-4-2 Electrostatic Discharge Immunity, Performance Criterion "B"
	IEC 61000-4-3 Radiated RF Electromagnetic Field Immunity ^{3,4} Performance Criterion "A"
	IEC 61000-4-4 Electrical Fast Transient/Burst Immunity, Performance Criterion "B"
	IEC 61000-4-5 Power Line Surge Immunity, Performance Criterion "B"
	IEC 61000-4-6 Conducted RF Immunity ³ , Performance Criterion "A"
	IEC 61000-4-11 Voltage Dips and Short Interruptions Immunity, Performance Criterion "B"

Appendix A: Specifications

Category	Standards or description
Australia Declaration of Conformity	Complies with EMC Framework and demonstrated per Emission standard: AS/NZS 2064 Industrial, Scientific, and Medical Equipment.
USA, FCC Compliance	Emissions comply with FCC Code of Federal Regulations 47, Part 15, Subpart B, Class A Limits.
EMC Compliance	Meets the intent of Directive 89/336/EEC for Electromagnetic Compatibility when used with the product(s) stated in the specifications table. Refer to the EMC specification published for the stated products. May not meet the intent of the directive if used with other products.
Equipment Type	Test and measuring
Safety Class	Class 3 (as defined in IEC 61010-1, Annex H)

Category	Standards or description
Pollution Degree	Pollution Degree 2 (as defined in IEC 61010-1). Note: Rated for indoor use only.
Pollution Degree Descriptions	<p>A measure of the contaminants that could occur in the environment around and within a product. Typically the internal environment inside a product is considered to be the same as the external. Products should be used only in the environment for which they are rated.</p> <p>Pollution Degree 1 No pollution or only dry, nonconductive pollution occurs. Products in this category are generally encapsulated, hermetically sealed, or located in clean rooms.</p> <p>Pollution Degree 2 Normally only dry, nonconductive pollution occurs. Occasionally a temporary conductivity that is caused by condensation must be expected. This location is a typical office/home environment. Temporary condensation occurs only when the product is out of service.</p> <p>Pollution Degree 3 Conductive pollution, or dry, nonconductive pollution that becomes conductive due to condensation. These are sheltered locations where neither temperature nor humidity is controlled. The area is protected from direct sunshine, rain, or direct wind.</p> <p>Pollution Degree 4 Pollution that generates persistent conductivity through conductive dust, rain, or snow. Typical outdoor locations.</p>

- 1 **Compliance demonstrated using high quality, shielded interface cables.**
- 2 **Minimum immunity test requirement, except where noted.**
- 3 **Performance Criterion: Product continues to operate properly and display remains readable.**
- 4 **Controlled EM environment requirement (1V/M).**

Appendix B: User Service

This section contains instructions for user and preventive maintenance. If the instrument is not functioning properly, it should be referred to qualified service personnel or returned to Tektronix for service. Packaging directions for shipment are on page 1-15.

Fuse Replacement

The WFM90D and WFM91D do not have any user replaceable fuses.

Battery Replacement

Instructions for installing or replacing the batteries along with battery operation tips are listed starting on page 1-7.

Cleaning and Maintenance

This section provides information about how to clean the instrument and how to perform preventive maintenance.

General Care

Protect the instrument from adverse weather conditions. The instrument is not waterproof.



CAUTION. *To avoid damage to the instrument, do not expose it to sprays, liquids, or solvents.*

Do not use chemical cleaning agents; they may damage the instrument. Avoid chemicals that contain benzene, toluene, xylene, acetone, or similar solvents.

Cleaning the Exterior

Clean the exterior surfaces of the instrument with a dry, lint-free cloth or a soft-bristle brush. If dirt remains, use a cloth or swab dampened with a 75% isopropyl alcohol solution. A swab is useful for cleaning in narrow spaces around the controls and connectors. Do not use abrasive compounds on any part of the instrument.

Interior

Interior cleaning and maintenance should be performed by qualified service personnel only. Instructions for interior maintenance are provided in the service manual.

Display

The LCD will retain an image if the instrument is left on in one display mode for an extended period of time. This is typical for the LCD display device. The retained image will fade over time, and that time can be accelerated by leaving the instrument turned off.



CAUTION. *LCD Display Image Retention*

To prevent image retention in the LCD display, enable the backlight time-out mode or turn the instrument off if the monitor will be left alone for more than two hours.

Instrument Adjustment

The WFM90D and WFM91D can be adjusted entirely from the front panel after entering the Calibration menu. The instrument should only be adjusted by qualified personnel. The service manual contains the instructions for adjusting the instrument.



Glossary

Glossary

AP CRC

Active picture CRC (Cyclic Redundancy Check).

Burst

A small reference packet of the subcarrier sine wave sent on every line of video. Since the carrier is suppressed, this phase and frequency reference is required for synchronous demodulation of the color difference signals in the receiver.

Chrominance

The color information in a television picture.

Chrominance Signal

The high-frequency portion of the video signal, that is obtained by quadrature amplitude modulation of a 4.43 MHz (PAL) or 3.58 MHz (NTSC) subcarrier with R-Y and B-Y information.

Color Bars

A video test signal, typically containing eight basic colors: white, yellow, cyan, green, magenta, red, blue, and black, is used to check chrominance functions of color TV systems.

There are two basic types of NTSC color bar signals in common use. The terms 75% bars and 100% bars are generally used to distinguish between the two types.

The 75%/100% nomenclature specifically refers to the maximum amplitudes reached by the Red, Green, and Blue signals when they form the six primary and secondary colors required for color bars. For 75% bars, the maximum amplitude of the RGB signals is 75% of the peak white level. For 100% bars, the RGB signals can extend up to 100% of peak white.

Color bar signals can also have different white bar levels, typically either 75% or 100%. This parameter is completely independent of the 75%/100% amplitude distinction and either white level may be associated with either type of bars. Because of setup, the 75% signal level for NTSC is at 77 IRE. The maximum available signal amplitude is 100 IRE.

Composite Video

A single video signal containing all of the necessary information to reproduce a color picture.

Cyclic Redundancy Check (CRC)

Binary polynomial used to generate check information on blocks of data. Similar to a checksum, but is harder to generate and more reliable.

Used in data transfer to check if the data has been corrupted. It is a check value calculated for a data stream by feeding it through a shifter with feedback terms “EXORed” back in. A CRC can detect errors, but not repair them, unlike an ECC, which is attached to almost any burst of data that might possibly be corrupted. CRCs are used on disks, ITU-R 601 data, Ethernet packets, and so forth.

Defaults

A set of behaviors specified on every system. You can later change these specifications.

Digital Component Video

Digital video using separate color components, such as YCbCr or RGB. See ITU-R BT.601-2.

Digital Video

A video signal represented by computer-readable binary numbers that describe colors and brightness levels.

dB (Decibel)

A logarithmic unit used to describe signal ratios. For voltages, $dB = 20 \text{ Log}_{10} (V_1/V_2)$.

EDH (Error Detection and Handling)

Method for recognizing inaccuracies in the serial digital signal. It may be incorporated into serial digital equipment and employ a simple error indicator.

Errored Second

A second of data transmission containing at least one error.

Field

Half of the video lines required to produce a full video frame. In interlaced scan systems, such as NTSC and PAL, the information for one video frame is divided into two fields. Two vertical scans overlay the two fields to produce the complete frame. In the complete frame, adjacent video lines in the picture are from alternate fields.

Frame

Contains all the information required for a complete picture. For interlaced scan systems, there are two fields in a frame.

FF CRC

Full field CRC.

Horizontal Blanking Interval

The horizontal blanking interval is the time between the end of one horizontal scanning line and the beginning of the next.

IRE

A unit equal to 1/140 of the peak-to-peak amplitude of the video signal, which is typically one volt. The 0 IRE point is at the blanking level, with the sync tip at -40 IRE and the white extending to +100 IRE. IRE stands for Institute of Radio Engineers, the organization that defined the unit.

Headroom

The difference between the nominal level (average) and the maximum operating level (just prior to unacceptable distortion) in any system or device. Because it is a pure ratio, there is no unit or reference-level qualifier associated with headroom; headroom expressed in dB accurately refers to both voltage and power.

Luminance

The signal (Y) that represents brightness, or the amount of light in the picture. This is the only signal required for black and white pictures. For color systems, it is obtained as a weighted sum ($Y = 0.3R + 0.59G + 0.11B$) of the R, G, and B signals.

NTSC

Acronym for National Television System Committee. The organization that developed the television standard currently in use in the United States, Canada, and Japan. Now, NTSC is generally used to refer to that standard.

PAL

Acronym for Phase Alternate Line. One of the television systems used in Europe and many other parts of the world. The phase of one of the color difference signals alternates from line to line to help cancel out phase errors.

RGB

Acronym for Red, Green and Blue. The three primary colors used in color television's additive color reproduction system. These are the three color components generated by the camera and used by the picture monitor to produce a picture.

Setup

In NTSC systems, video black is typically 7.5 IRE above the blanking level. This 7.5 IRE level is referred to as the black setup level, or simply setup.

Termination

An impedance at the end of a transmission line that matches the impedance of the source and of the line itself. Proper termination prevents amplitude errors and reflections. Video systems use 75 Ω transmission lines, so a 75 Ω terminator must be at the end of any signal path. A receiving device connected to the transmission line may provide the necessary termination.

Vertical Interval

The vertical blanking interval is the time between the end of one video field and the beginning of the next. Synchronizing information appears between fields and tells the picture monitor to go back to the top of the screen to begin another vertical scan.

Y

Abbreviation for luminance.



Index

Index

>CABLE, 2-12

A

AC adapter, 2-12
Accessing menus, 2-25
Accessories, 1-6
 ordering, 1-6
 part numbers, 1-6
Address, Tektronix, x
Adjustment, B-2
Alkaline batteries, replacement,
 1-10
Amplitude alarm, 2-11
Analog input, 2-44
ANALOG readout, 2-9
Arrow buttons, 2-4
Audio amplitude measurements,
 3-10
AUDIO button, 2-1
Audio display mode, 2-11
Audio frequency response mea-
 surements, 3-10
Audio graticule, 3-9
Audio headroom measurements,
 3-10
AUDIO IN connector, 2-5
Audio operating menu, 2-28
Audio out connector, 2-5
Auto input control, 2-44

B

Backlight time-out, 2-18

Battery

alkaline, 1-10
NiMH, 1-8
operation, 1-7, 2-12
recharging (NiMH), 1-8
replacing (alkaline), 1-10
Bezel buttons, 2-3
BLUE (readout), 2-7

C

C (readout), 2-7
Cable report, 2-12
Cable report readout, 2-8
Calibration mode, 2-13
Checkout procedure, 2-39
Chroma bandwidth measurements,
 3-7
Cleaning, the instrument, B-1
Component display, 2-45
Component readout, 2-7
COMPOSIT (readout), 2-7
Composite select, 2-26
CONFIG button, 2-3
Configuration menu, 2-31
 ALARMS category, 2-34
 DISPLAY category, 2-33
 INPUT category, 2-33
 INTENS category, 2-33
 PICTURE category, 2-34
 PRESETS category, 2-34, 2-35
 TIME-OUT category, 2-34
 VAR GAIN category, 2-33
 VECTOR category, 2-34

Connectors, 2-5
Contacting Tektronix, x
CRC, 2-26
CRC readout, 2-8
CRC Watch, 2-45
 using for stress testing, 3-8

D

DC power connector, 2-5
DC restorer, 3-3
Default settings, 2-35
Desk stand, 1-12
Differential gain measurements,
 3-5
Differential phase measurements,
 3-5
Digital input, 2-44
Digital menu, 2-25
DIGITAL readout, 2-9
Digital signal monitoring, 2-20,
 2-45
Digital video standards supported,
 2-16
Display device, 2-15
 image retention, 2-15
Display mode selection, 2-1
Display readout, 2-7

E

EDH Report, 2-45
EDH report, 2-15, 2-26, 2-27,
 2-29, 2-30
EDH report readout, 2-8
Electrical installation, 1-7
 batteries (alkaline), 1-10
 battery (NiMH), 1-8
Error reporting, 2-15

ERRORED SECONDS, 2-8
EXT REF connector, 2-5
EXT REF readout, 2-7

F

FLAT filter, 2-26
Front panel controls, 2-1
Fuse, replacement, B-1

G

GAIN, 2-26, 2-27
GAIN UNCAL readout, 2-8
Graticule
 audio, 3-9
 vector, 3-4
 waveform, 3-1
GREEN (readout), 2-7

H

Headphone connector, 2-5
Headroom, 3-10
Hood, 1-11
Horizontal gain, 2-26

I

Input control, 2-16
Input control , 2-44
Installation
 desk stand, 1-12
 electrical, 1-7
 mechanical, 1-11
 travel case, 1-13
 viewing hood, 1-11

- Instrument
 - calibration, 2-13
 - cleaning, B-1
 - DC power input, 2-5
 - default settings, 2-35
 - keypad illustration, 2-2
 - reset, 2-4
 - service, B-1
 - side panel illustrations, 2-6
 - software version, 2-8
 - time-out, 2-18
- Instrument Accessories, 1-6
- Instrument options, 1-5

- J**
- Jumpers, 1-7

- K**
- Keypad controls, 2-1

- L**
- LCD display, 2-15
- LINE SEL button, 2-3
- Line Select menu, 2-37
- Line Select mode, 2-17
- LOW BAT readout, 2-8
- LUM filter, 2-26

- M**
- MAG, 2-26
- Measurements, 3-1
 - audio, 3-10
 - audio amplitude, 3-10
 - chroma bandwidth, 3-7
 - dc restorer, 3-3
 - differential phase and gain, 3-5
 - peak white, 3-3
 - vector, 3-7
 - waveform display mode, 3-3
- Mechanical installation, 1-11
- MENU button, 2-3
- Menu control, 2-3
- Menu operation, 2-23
 - configuration, 2-31
 - line select, 2-37
 - operating, 2-25
- Menu selections
 - action, 2-29
 - alarm, 2-34
 - alt field, 2-37
 - alt ph, 2-34
 - audio, 2-30
 - back lt, 2-34
 - bars, 2-34
 - bright, 2-33
 - color, 2-34
 - comp sel, 2-26
 - dc rest, 2-33
 - default, 2-35
 - EDH rpt, 2-26, 2-27, 2-29, 2-30
 - fields, 2-37
 - filter, 2-26
 - gain, 2-26, 2-27
 - grat, 2-33
 - headroom, 2-28
 - hue, 2-34
 - location, 2-30
 - mag, 2-26
 - recall, 2-34
 - ref, 2-33
 - reference dBu, 2-28
 - safe area, 2-29
 - setup, 2-34

- shutdown, 2-34
- store, 2-34
- sweep, 2-26
- title, 2-29
- trace, 2-33
- v shift, 2-29
- vect, 2-30
- view, 2-33
- wfm, 2-30

MISSING SYNC readout, 2-8

N

- NiMH batteries, 1-8
- NO SYNC, 2-8

O

- Onscreen readouts, 2-7
- Operating menus, 2-25
- Operator's familiarization procedure, 2-39
- Options, 1-5
- Ordering accessories, 1-5

P

- Packaging instructions, 1-15
- PB (readout), 2-7
- Performance specification, A-1
- Phone number, Tektronix, x
- Picture display mode, 2-17
- Picture operating menu, 2-29
- PIX button, 2-1
- Power connector, 2-5
- Power source, 1-7
- Power switch, 2-1
- PR (readout), 2-7
- Preset menu, 2-17

- Product support, contact information, x

R

- Readout description, 2-7
- Readouts, 2-7
- Rear-panel connectors, 2-5
- RED (readout), 2-7
- Reset, 2-4

S

- Select a component for display, 2-26
- Service
 - cleaning, B-1
 - fuse replacement, B-1
- Service support, contact information, x
- Setup, graticule, 3-2
- Side-panel connectors, 2-5
- Software version readout, 2-8
- Specification, electrical, A-1
- Stand, 1-12
- Stress testing, 3-8
- Supported video standards, 2-16
- Sweep rate, 2-26
- Sweep rate readout, 2-8
- Sweep rates, 3-2
- Switches, 2-5

T

- Technical support, contact information, x
- Tektronix, contacting, x
- Time-out mode, 2-18
- Time-out mode, 2-18

Travel case, 1-13
 packing, 1-13
Tutorial, 2-39
 required equipment, 2-39

U

UNLOCK readout, 2-9
URL, Tektronix, x
User service, B-1

V

Variable gain, 2-18
VECT button, 2-1
Vector display mode, 2-19
Vector graticule, 3-4
 chrominance targets, 3-5
 differential phase and gain, 3-5
Vector operating menu, 2-27
Vertical gain, 2-26, 2-27
Video and audio input, 2-16
Video and Audio Output, 2-16

VIDEO IN connector, 2-5
Video input signals, 2-16
VIDEO OUT connector, 2-5
Video standards, 2-16
Viewing hood, 1-11

W

Waveform display mode, 2-20
Waveform graticule, 3-1
Waveform operating menu, 2-26

Waveform-in-Picture display mode,
2-21
Web site address, Tektronix, x
WFM button, 2-1
WIP button, 2-1
WIP display mode, 2-21
WIP operating menu, 2-30

Y

Y (readout), 2-7