

# TM 500 POWER MODULE TESTER AND UTILITY POWER SUPPLY

Construction Note

UPDATED VERSION

V1.4-2021/01

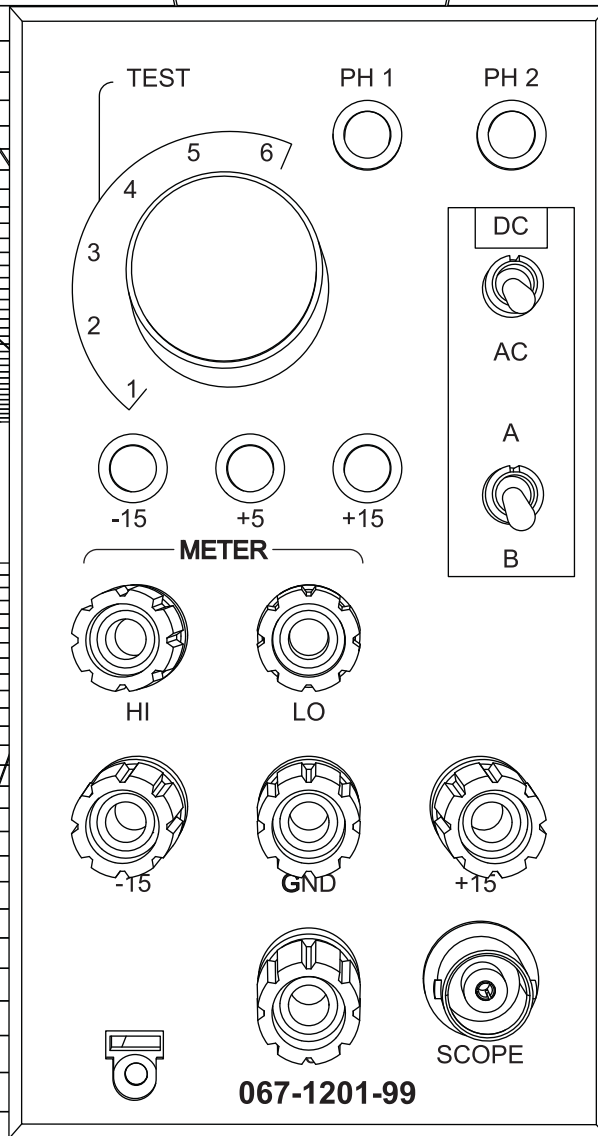

# TM500 POWER MODULE TESTER AND UTILITY POWER SUPPLY

By Warren Collier, Program Supervisor

TM 500 Marketing, Tektronix, Inc.

Modified and updated by Jared Cabot - Near Far media 2020/12

## I. INTRODUCTION

This note describes the construction of a single-width TM 500 plug-in utilizing the blank plug-in kit. P/N 040-0652-02.

The plug-in's primary purpose is to test TM 500 series power modules (mainframes) It is also useful as a limited performance power supply for breadboard or student use.

In its primary function as a test unit, it checks only the integrity of mainframe power supply components. It does not check "interface" connections; these checks (when applicable) may be made with a simple ohmmeter or continuity tester.

This note also includes instructions for mainframe tests using the completed plug-in.

As a utility power supply, the unit supplies the following voltages:

1. +5 VDC nominal at 1 Amp. Suitable for TTL or similar logic, and compatible displays. (Type 7805 regulator.)
2. +15 VDC and -15 VDC rated at 400 mA, with short circuit protection. The common of these supplies is grounded. Output voltage and current limiting are not variable.

*NOTE: When using this unit as a power supply, set the rotary switch to position 3 and the AC/DC switch to the DC position.*

## II. ASSEMBLY OF TEST UNIT

1. Preparation of the rotary switch consists of inserting the two limiter pins into the 12 o'clock and 6 o'clock position then applying the foil sticker to retain the pins in place. This will limit the switch to 6 positions and ensure it works correctly as a 4P6T switch. See Fig. 1 for details.

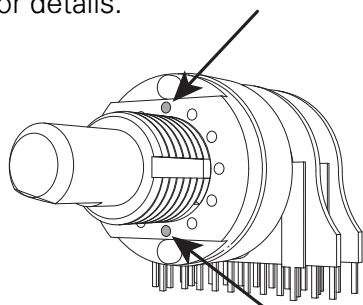

Fig. 1

2. To assemble the front panel, use the Front Panel Template to mark out the holes to be drilled. Overlay the Face Place PCB to ensure it all lines up correctly and adjust if required.

Clamp the plastic and aluminium front panels together and drill the holes through both pieces at the same time to ensure the holes are perfectly aligned.

Install the LED holder clips into the Face Plate, using a minimal amount of superglue to fix them in place.

Assemble the side panels to the front panels to construct the chassis.

Place the Face Place in place on the front panel and install all the binding posts and the BNC jack.

It may help to use a scrap portion of a Face Plate PCB on the rear of the front panel assembly to help align the rear part of the binding posts.

Install the completed Range Switch PCB onto the completed Main PCB.

Complete the Front Panel PCB, WITHOUT soldering the LED's into place.

Place the LED's into their locations on the Front Panel PCB (WITHOUT soldering them) and carefully slide the entire assembly into place in the chassis.

You may need to make a washer from some scrap 1mm PCB material to place on the rotary switch before sliding it into position, determine with a test fit.

Once the assembly is installed, the three switches have their lock nuts installed and the Main PCB is screwed into place. Ensure the Front Panel PCB is parallel to the front panel.

Use a small screwdriver to push the LED's into their panel clips and ensure they are seated correctly.

Solder the LED's and binding posts to the Front Panel PCB. This will ensure they are fixed at the exact distance for proper fitment.

3. The 7805 regulator may be heat sunk by mounting directly to the chassis frame.

Drill a 3.5mm countersunk hole in the appropriate location on the chassis and install the main PCB.

The correct location can be easily determined by installing the Main PCB and sliding the regulator into place WITHOUT soldering it in.

Form the leads carefully to allow the regulator to lay flat on the side panel and mark the location of the hole to be drilled.

Bolt the regulator in place with the leads through the respective holes in the PCB.

Now solder the leads to the Main PCB. This will ensure that no undue stress is placed on the leads, PCB, and regulator body.

The screw may now be removed to allow removal of the Main PCB as required.

Ensure that good quality thermal grease is used between the regulator and chassis upon final assembly.

No insulating washer or pad is required in this location.

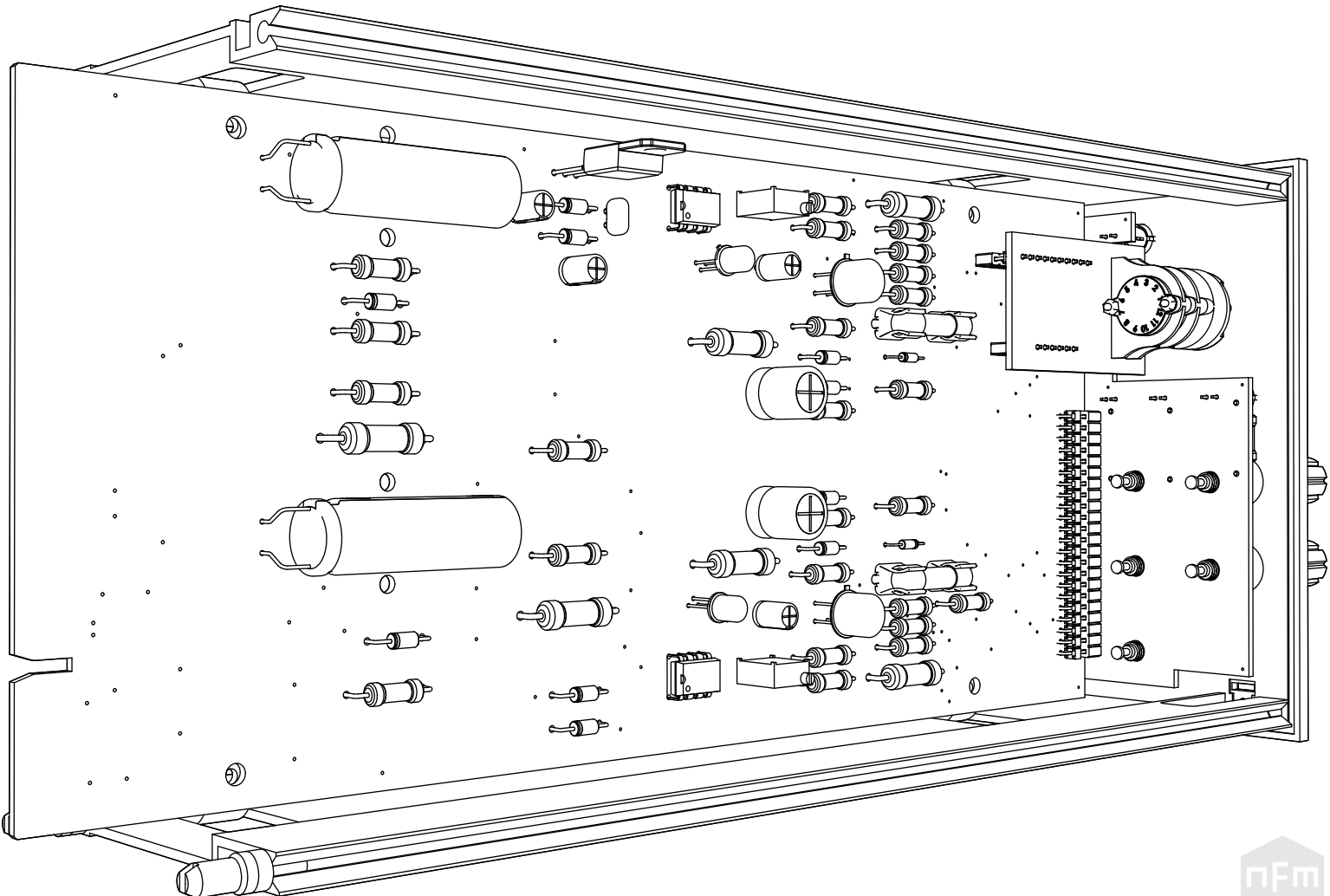
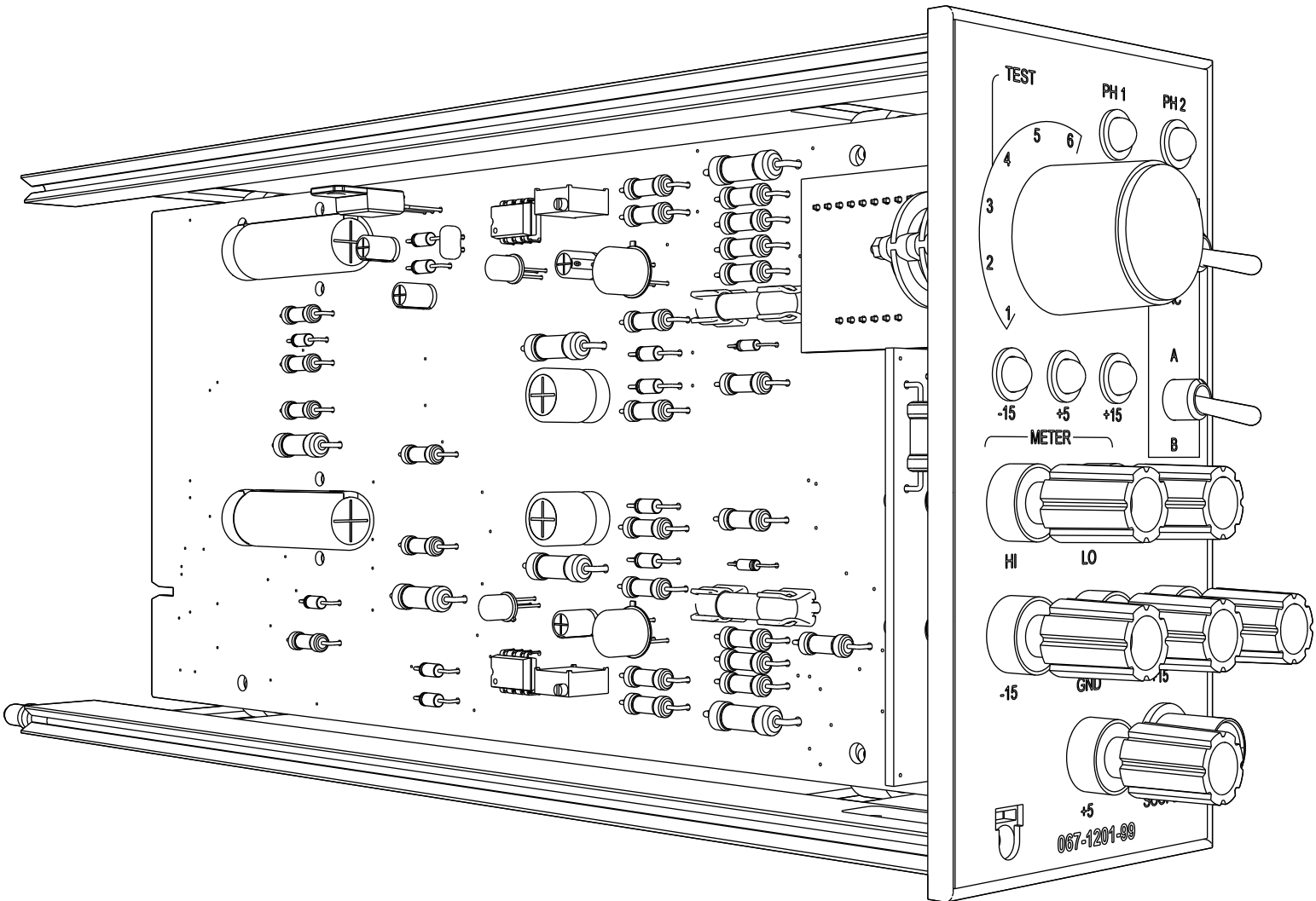

### III. PARTS LIST - MAINFRAME TESTER

#### IC's

2	uA741CN	U1, U2
1	7805	U5

#### Transistors

1	2N2219A	Q121
1	2N2222A	Q122
1	2N2905A	Q221
1	2N2907A	Q222

#### Diodes

2	1N751A	CD121, CR221
6	1N4007	CR1, CR101, CR123, CR223, CR501, CR502
4	1N4148	CR2, CR102, CR122, CR222

#### LED's - 5mm T-1 3/4 10-20mA

2	Red	DS1, DS2
3	Green	DS120, DS220, DS501

#### Capacitors

2	1000uF/50V	C1, C101 - EKZN500ELL102MK35S
2	82uF/63V	C122, C222 - EKZE630ELL820MJC5S
1	100uF/16V	C501 - EKZE250ELL101MF11D
2	22uF/35V - TANT	C121, C221 - TAP226K035SRW
1	1uF/50V - TANT	C2 - TAP15K035SRW
1	0.1uF/50V	C3 - Ceramic 5mm pitch

#### Resistors

4	1Ω 2W Wirewound	R1, R101, R135, R235
2	300Ω 3W Wirewound	R124, R224
4	22kΩ 1/2W	R2, R102, R121, R221
2	1kΩ 1/2W	R4, R104
2	4.99kΩ 1/2W	R128, R228
2	7.5kΩ 1/2W	R126, R226
2	1.8kΩ 1/2W	R122, R222
6	5.1kΩ 1/2W	R5, R123, R133, R223, R233, R240
2	12kΩ 1/2W	R129, R229
6	1.5kΩ 1/2W	R3, R103, R125, R225, R130, R230
1	360Ω 1/2W	R501

#### Trimpots

2	5K	Bourns 3296W R127, R227
---	----	-------------------------

#### Switches

1	DPDT	S1 - 7201SYCQE or equivalent
1	SPDT	S2 - 7101SYCBE or equivalent
1	4P6T Rotary	S3 - 71BDF30-02-2-AJN

#### Fuses

2	5x20 0.8A	Slow Blow
4	Fuse holders	FC-211-22

#### Connectors

3	3760-2	Red Binding Post
1	3760-9	White Binding Post
1	3760-0	Black Binding Post
1	3760-5	Green Binding Post
1	5227169-7	BNC Female, Panel Mnt, Long Thread
1	TSW-122-08-G-S-RA	22 Way Male Header, 90 Deg
1	SLW-122-01-G-S	22 Way Female Header
1	TSW-110-07-G-S	10 Way Male Header
1	SLW-110-01-G-S	10 Way Female Header
1	TSW-106-07-G-S	6 Way Male Header
1	SLW-106-01-G-S	6 Way Female Header

#### Misc.

1	Knob	Black, 22mm Diameter, 6.35mm Shaft
1	M3 Countersunk screw, split washer, washer, nut	
5	C-174	5mm LED Holder Panel Clip
1	040-0652-02	Blank plugin kit, or spare scrap module

### IV. POWER MODULE (MAINFRAME) TEST PROCEDURES

#### Introduction

Since the TM 500 power modules do not contain regulated supplies, test procedures are intended simply to ensure that power supply components are functional; that is, that they have neither failed catastrophically, nor suffered appreciable degradation.

Although test limits are given, they are intended as maintenance guidelines rather than formal specifications. The mainframe contains no adjustments and doesn't require "calibration" as the term is usually applied.

#### Circuit Analysis

1. +/-33.5 VDC supplies.

These dc supplies consist of a pair of transformer windings (equivalent to a tapped winding) feeding a full wave bridge rectifier which is followed by filter capacitors and bleeder resistors. Since there is no regulation circuitry, the plus and minus voltages increase and decrease as the primary line voltage increases and decreases. When the line voltage is at its nominal value and there is no external load on the supply, the DC voltages are nominally plus and minus 33.5 V. The effect of load current is to decrease output DC voltage and increase peak-to-peak ripple voltage. These supplies are connected in parallel to all compartments.

2. NPN and PNP pass transistors.

The pass transistors are isolated units whose collector, emitter, and base leads are brought to the interface connector, allowing each plug-in to utilize them as desired. In this test unit the NPN is used as a series regulator in the +15 V supply and the PNP as a series regulator in the -15 V supply. There is a separate pair of transistors for each compartment.

3. 25 VAC RMS floating windings.

Each compartment has two such windings supplied to it; they are secondary windings of the main power transformer. They should be connected so that pins 1A, 2A. and 13A are in phase. This allows their voltages to be additive when series-connected. The test unit connects pins 1A and 13A to ground and compares the phase of 1B and 13B to the phase of 5B. The test unit also half-wave rectifies both floating windings. One winding produces a positive voltage and the other a negative voltage. These voltages are substituted for the +/-33.5 V supplies when the AC/DC switch is in the AC position, allowing a test of voltage and current capacity.

4. +12 V DC supply.  
This supply consists of a pair of transformer windings (equivalent to a tapped winding) feeding a 2-diode full wave rectifier, followed by a filter capacitor and bleeder resistor. This supply is connected in parallel to all standard (low power) compartments. The common is isolated from ground in the mainframe by a one-kilohm resistor but is grounded by the TM 500 plug-ins. The high power compartment (far right hole of a TM 504 or TM 506) has a separate 12 V supply for it self which may or may not be grounded by the plug-in.

The test unit uses the 12 VDC supply as the raw voltage which is regulated by the 7805 5 V regulator.

The unrectified voltage from these windings is connected to pins 5A and 5B. Except for the phase comparison previously described, these connections are not checked. Any winding failure will be detected in the check of the 12 V supply. Lack of AC voltage at pins 5A and 5B (when the 12 V DC supply is working) would be due to a broken run or connector.

## General Instructions

1. The test procedure for the mainframe assumes that the test load is properly assembled and in good working order.
2. Two external load resistances are required. The recommended wattage ratings are the minimum required for adequate performance. At these wattage ratings, the surface temperature under load may be too great for safe handling. Therefore, the loads should be encased or shielded. As an alternative, a wattage rating five to ten times the minimum value will produce lower surface temperatures.  
The loads are:
  - a. 30 ohm, 10 W minimum; used with +15 V and -15 V supplies.
  - b. 5 ohms, 5 W minimum; used with +5 V supply
3. The HI and LO meter terminals are for connection to an external test meter. In some tests, the HI terminal is positive relative to the LO terminal, and in some it is negative. The unit is designed for use with an autopolarity DVM having an input resistance of at least 10 megohms.  
The DM 502 is a good choice for this application.
4. The BNC connector in parallel with the HI meter terminal is for use with an oscilloscope. It is expected that an oscilloscope will be used to monitor ripple voltage on certain tests. These are low frequency tests and the

bandwidth of the instrument is not important. The scope will be used mostly AC-coupled and should have a calibrated vertical scale and time base. If an oscilloscope is not available, checks can be accomplished with only the meter.

5. Several of the bused supply terminals have multiple connections:
  - a. +33.5 V, pins 12A and 12B
  - b. -33.5 V, pins 8A and 8B
  - c. +/-33.5 V common, pins 9A and 9B
  - d. +12 V, pins 2A and 2B
  - e. +12 V common, pins 3A, 3B, 4A, and 4B

The circuit board for the blank plug-in kit parallels each of these sets. However a given plug-in may use only one contact. The test unit can show the compartment to be good, whereas one contact of a pair may be broken or have an open run, producing trouble with some particular plug-in units other than the test unit.

6. In most instances, steps IIIA, IIIB, VIA, and VIB of the power module test procedure are necessary in only one compartment of a main frame. However, it is possible that another compartment would lack voltage due to a broken run or contact. Step VIII should always be performed in a high power compartment (far right of TM 504 or TM 506) as well as at least one of the standard compartments.

# DETAILED TEST PROCEDURE

## Step 1 - NPN Short/Leakage

### Presets:

Meter Switch	Position 1
AC/DC Selector	AC
A/B Selector	A
External Load	Disconnected

### Procedure:

This test grounds the base of the NPN transistor to turn it off.

Check to see that +15 V indicator LED is extinguished and that the meter reading drifts down to zero (or nearly zero) as the output filter capacitor in the +15 V supply discharges. A residual reading greater than 10 mV indicates that the NPN pass transistor in the mainframe is leaky (or shorted) from collector to emitter.

A base-emitter short will result in a loss of regulation (reduced output voltage) in Step IIIB. This will cause the +15 V indicator light to dim. Another symptom of a base-emitter short is that the output voltage of the +15 V supply goes to zero more rapidly than normal when switching from position 2 to position 1.

NPN base-collector leakage will be evidenced by an output voltage (+15 V supply) greater than normal in position 2 or 3. A base-collector short should produce the same symptom and will also result in a blown fuse F1 in position 1

Fuse F1 will also blow if the NPN collector is shorted to the chassis.

## Step II - NPN Beta

### Presets:

Meter Switch	Position 2
AC/DC Selector	AC
A/B Selector	A
External Load	30Ω connected to +15V

### Procedure:

*CAUTION: Surface temperature of test load resistors may become too hot for safe handling. Refer to general instruction no. 2.*

The meter displays a voltage which is proportional to the base current of the NPN pass transistor in this mainframe compartment. A high reading means low beta, and a low reading means high beta. Disconnect the oscilloscope for this test to prevent erroneous readings.

Consider replacement of any transistor that shows a reading greater than 3.0 V.

Removing the external load should cause the reading to reduce to a much smaller value.

A zero (or extremely low) reading may be due to low output from the +15 V supply. Check raw DC and pass transistor.

## Step IIIA - +33.5 V DC Supply (unloaded)

### Presets:

Meter Switch	Position 3
AC/DC Selector	DC
A/B Selector	A
External Load	Disconnected

### Procedure:

The meter displays the raw DC voltage supplied by the mainframe to pins 12A and 12B, and the scope displays the ripple voltage. If a variable auto transformer is available, set the primary line voltage to the center value of the tap in use. Refer to Table 1 for the appropriate values.

Inadequate performance is most likely due to a defective rectifier or filter capacitor in the +33.5 volt supply. A defective power transformer is another possibility. If no voltage is present, a blown fuse in the mainframe or in the test unit is a possibility.

## Step IIIB - +33.5 V DC Supply (loaded)

### Procedure:

*CAUTION: Surface temperature of test load resistors may become too hot for safe handling. Refer to general instruction no. 2.*

With the controls still set as in Step IIIA, connect the 30 ohm load to the +15 V supply. There will be a decrease in the DC voltage displayed by the meter, and an increase in the peak-to-peak ripple displayed by the oscilloscope. Refer to Table 2. Inadequate performance is likely due to the same causes listed above.

## Step IIIC - AC Winding (pins 13A/13B)

### Procedure:

With the controls still set as in Step IIIB (and with the 30 ohm load still connected), throw the AC/DC switch to the AC position. There will be a further decrease in the DC voltage displayed by the meter, and an increase in the peak-to-peak ripple displayed by the oscilloscope.

Typical value is 22 - 28 V, with a peak-to-peak ripple of 6 - 11 V. The ripple voltage is a function of the filter capacitors in the test unit and will be fairly constant. See Table 1 and Table 2 for other considerations. (The ripple frequency will also change from 120 Hz to 60 Hz). These changes are due to the half wave rectifier and the smaller filter capacitor in the test unit. Disconnect the 30 ohm load; the DC voltage should increase to approximately 32 - 35 V. Return the AC/DC switch to the DC position. Failure to supply adequate voltage in this step implies that the AC winding connected to pins 13A and 13B is defective.

## Step IV - PNP Short/Leakage

### Presets:

Meter Switch	Position 4
AC/DC Selector	AC
A/B Selector	A
External Load	Disconnected

### Procedure:

This test grounds the base of the NPN transistor to turn it off.

Check to see that the -15 V indicator LED is extinguished and that the meter reading drifts down to zero (or nearly zero as the output filter capacitor in the -15 V supply discharges). A residual reading greater than 10 mV indicates that the PNP pass transistor in this mainframe compartment has excessive leakage or may be shorted from collector to emitter.

A base-emitter short will result in a loss of regulation (reduced output voltage) in Step VIB. This will cause the -15 V indicator light to dim.

Another symptom of a base-emitter short is the output voltage of the -15 V supply dropping to zero more rapidly than normal when switching from position 5 to position 4.

PNP base-collector leakage will be evidenced by an output voltage (-15 V supply) greater than normal in positions 5 or 6. A base-collector short should produce the same symptom and will also result in a blown fuse in position 4. Fuse F2 will also blow if the PNP collector is shorted to the chassis.

## Step V - PNP Beta

### Presets:

Meter Switch	Position 5
AC/DC Selector	AC
A/B Selector	A
External Load	30Ω connected to -15V

### Procedure:

*CAUTION: Surface temperature of test load resistors may become too hot for safe handling. Refer to general instruction no. 2.*

The meter displays voltage which is proportional to the base current of the PNP pass transistor in this mainframe compartment. A high reading means low beta, and a low reading means high beta. Disconnect the oscilloscope for this test to prevent erroneous readings.

Consider replacement of any transistor that shows a reading greater than 3.0 V.

Removing the external load should cause the reading to reduce to a much smaller value.

A zero (or extremely low) reading may be due to low output from the -15 V supply. Check raw DC and pass transistor.

## Step VIA - -33.5 V DC Supply (unloaded)

### Presets:

Meter Switch	Position 6
AC/DC Selector	DC
A/B Selector	A
External Load	Disconnected

### Procedure:

The meter displays the raw voltage supplied by the mainframe to pins 8A and 8B, and the scope displays the ripple voltage. If a variable auto transformer is available, set the primary line voltage to the center value of the tap in use. Refer to Table 1 for the appropriate values.

Inadequate performance is most likely due to a defective rectifier or filter capacitor in the -33.5 V supply. A defective power transformer is another possibility. If no voltage is present, a blown fuse in the mainframe or in the test unit is a possibility.

## Step VIB - -33.5 V DC Supply (loaded)

### Procedure:

*CAUTION: Surface temperature of test load resistors may become too hot for safe handling. Refer to general instruction no. 2.*

With the controls still set as in Step VIA, connect the 30 ohm load to the -15 V supply. There will be a decrease in the DC voltage displayed by the meter, and an increase in the peak-to-peak ripple displayed by the oscilloscope. Refer to Table 2. Inadequate performance is likely due to the same causes listed above.

## Step VIC - AC Winding (pins 1A and 1B)

### Procedure:

With the controls still set as in Step VIB (and with the 30 ohm load still connected), throw the AC/DC switch to the AC position. There will be a further decrease in the DC voltage displayed by the meter, and an increase in the peak-to-peak ripple displayed by the oscilloscope. Typical value is 22 - 28 V, with a peak-to-peak ripple of 6 - 11 V. The ripple voltage is a function of the filter capacitors in the test unit, and will be fairly constant. See Table 1 and Table 2 for other considerations (The ripple frequency will also change from 120 Hz to 60 Hz). These changes are due to the half wave rectifier and the smaller filter capacitor in the test unit. Disconnect the 30 ohm load; the DC voltage should increase to approximately 32 - 35 V.

Return the AC/DC switch to the DC position. Failure to supply adequate voltage in this step implies that the AC winding connected to pins 1A and 1B is defective.

## Step VII - Phasing of AC Windings

By now, both AC floating windings supplied to the compartment have been checked for adequate voltage and current. If their phasing relative to each other and to the windings connected to pins 5A and 5B is correct. DS1 and DS2 will be extinguished.

If DS2 is lit, reverse the transformer leads to pins 1A and 1B

If DS1 is lit, reverse the transformer leads to pins 13A and 13B.

## Step VIII - +12 V DC Supply

### Presets:

Meter Switch	Position 1
AC/DC Selector	AC
A/B Selector	B
External Load	Disconnected

### Procedure:

The meter displays the raw 12 V DC voltage supplied to pins 2A and 2B. Refer to Table 3 for proper values.

*CAUTION: Surface temperature of test load resistors may become too hot for safe handling. Refer to general instruction no. 2.*

Connect the 5 ohm load to the +5 V supply. There will be a decrease in DC voltage displayed by the meter. and an increase in peak-to-peak ripple displayed by the oscilloscope, as shown by Table 4.

Inadequate performance is probably due to a defective diode or filter capacitor in the mainframe supply. A defective transformer winding or a blown fuse is another possibility.

This completes the tests for this compartment.



**TABLE 1**

TM501	TM503	TM504	TM506	TM515
34.3 +/-0.5	33.3 +/-0.5	33.5 +/-0.5	33.6 +/-0.5	33.7 +/-0.5

**Plus and minus 33.5 V DC based supplies.**

Typical no load voltage at 60 Hz, and with line voltage adjusted for center of range.

These voltages are quite dependent on line voltage and are sensitive to line voltage waveform distortion.

**TABLE 2**

TM501	TM503	TM504	TM506	TM515
≥ 28.0 V	≥ 29.5 V	≥ 31.5 V	≥ 31.6 V	≥ 30.5 V
≤ 2.6 V	≤ 1.4 V	≤ 650 mV	≤ 600 mV	≤ 600 mV

**Plus and minus 33.5 V DC based supplies.**

DC voltage with 500 mA load (upper) and peak-to-peak ripple with 500 mA load (lower).

These are approximate worse-case values at 60 Hz and with line voltage adjusted for center of range. At 50 Hz ripple will increase by about 25%, with a corresponding decrease in DC voltage. (DC voltage will decrease by about 60% of the increase in peak-to-peak ripple.)

The DC voltage is quite sensitive to line voltage, including waveform distortion.

**TABLE 3**

TM501	TM503	TM504	TM506	TM515
12.8 +/-0.5	11.7 +/-0.5	13.2 +/-0.5	13.7 +/-0.5	14.0 +/-0.5
N/A	N/A	13.2 +/-0.5	13.7 +/-0.5	N/A

**12 V DC supply.**

Typical no load voltage at 60 Hz and with line voltage adjusted for center of range.

These voltages are quite dependent on line voltage and are sensitive to line voltage waveform distortion.

Upper number is supply bused to standard compartments.

Lower number is for high power compartment.

**TABLE 4**

TM501	TM503	TM504	TM506	TM515
≥ 9.3 V	≥ 9.7 V	≥ 11.7 V	≥ 12.5 V	≥ 12.2V
N/A	N/A	≥ 11.7 V	≥ 12.5 V	N/A
≤ 1.8 V	≤ 1.0 V	≤ 600 mV	≤ 600 mV	≤ 600 mV
N/A	N/A	≤ 600 mV	≤ 600 mV	N/A

**12 V DC supply.**

DC voltage and peak-to-peak ripple with 1.0 A load. First row is DC voltage at standard compartment; second row is DC voltage at higher power compartment; third row is peak-to-peak ripple at standard compartment; fourth row is peak-to-peak ripple at high power compartment.

These are approximate worse-case values at 60 Hz and with line voltage adjusted for center of range. At 50 Hz, ripple will increase by about 25% with a corresponding decrease in dc voltage. (DC voltage will decrease by about 60% of the increase in peak-to-peak ripple.)

The DC voltage is quite sensitive to line voltage, including waveform distortion.

**IMPORTANT NOTE**

*It is the user's responsibility to follow good engineering practice, including the observance of all applicable safety procedures. In designing, constructing, and using any device described in this Construction Note. And while the suggested circuits for TM 500 blank plug-in kits are believed to be suitable for the described application, Tektronix and NFM does not guarantee their performance or warrant that they are useful for any particular purpose, and no such warranty should be implied. Finally, because Tektronix and NFM has no control over the construction or use of equipment built using TM 500 Construction Notes. It follows that Tektronix and NFM can accept no responsibility whatsoever for any claim or loss arising either directly or consequently from such construction or use.*

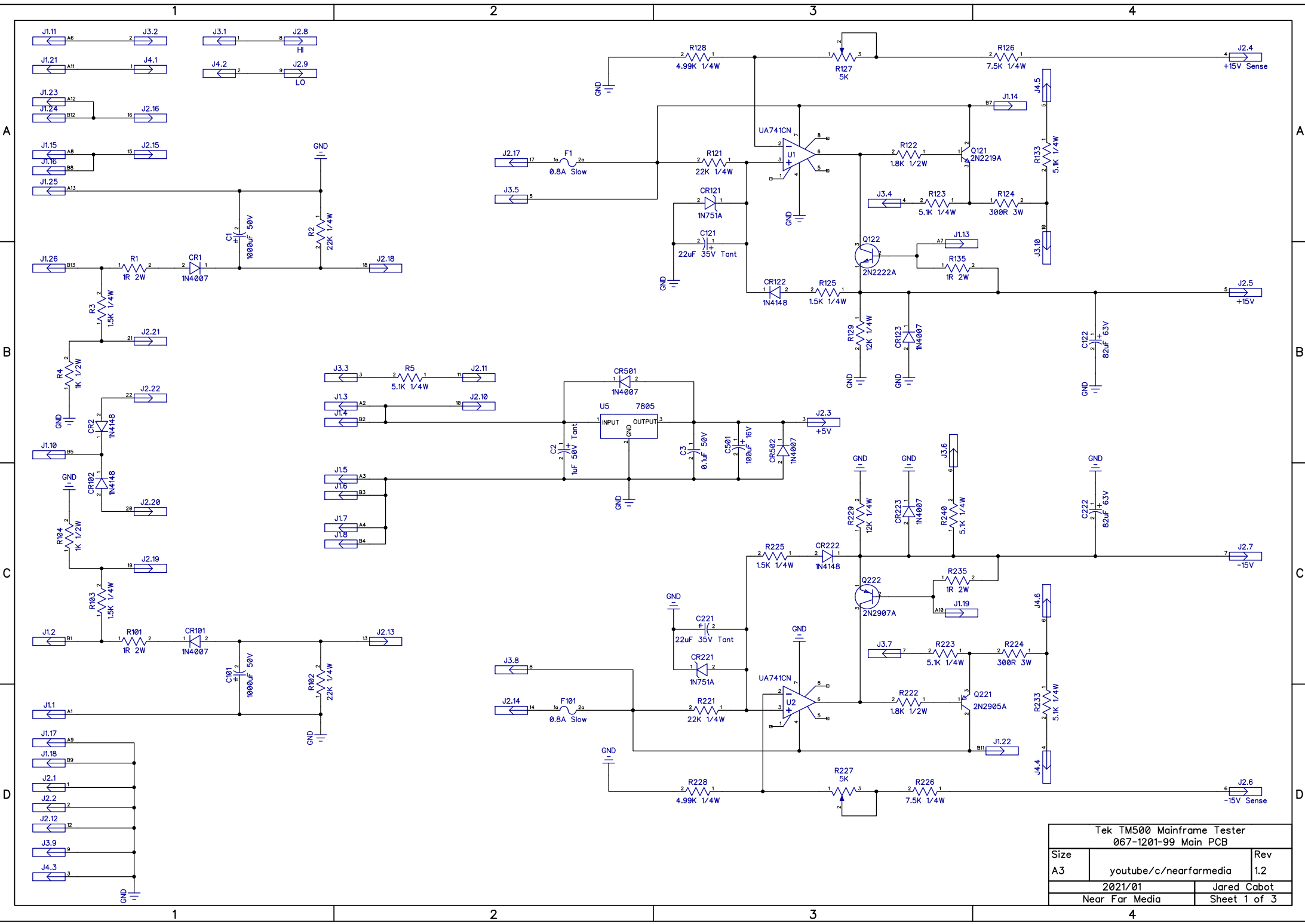

Tek TM500 Mainframe Tester		
067-1201-99 Main PCB		
Size		Rev
A3	youtube/c/nearfarmedia	1.2
2021/01		Jared Cabot
Near Far Media		Sheet 1 of 3

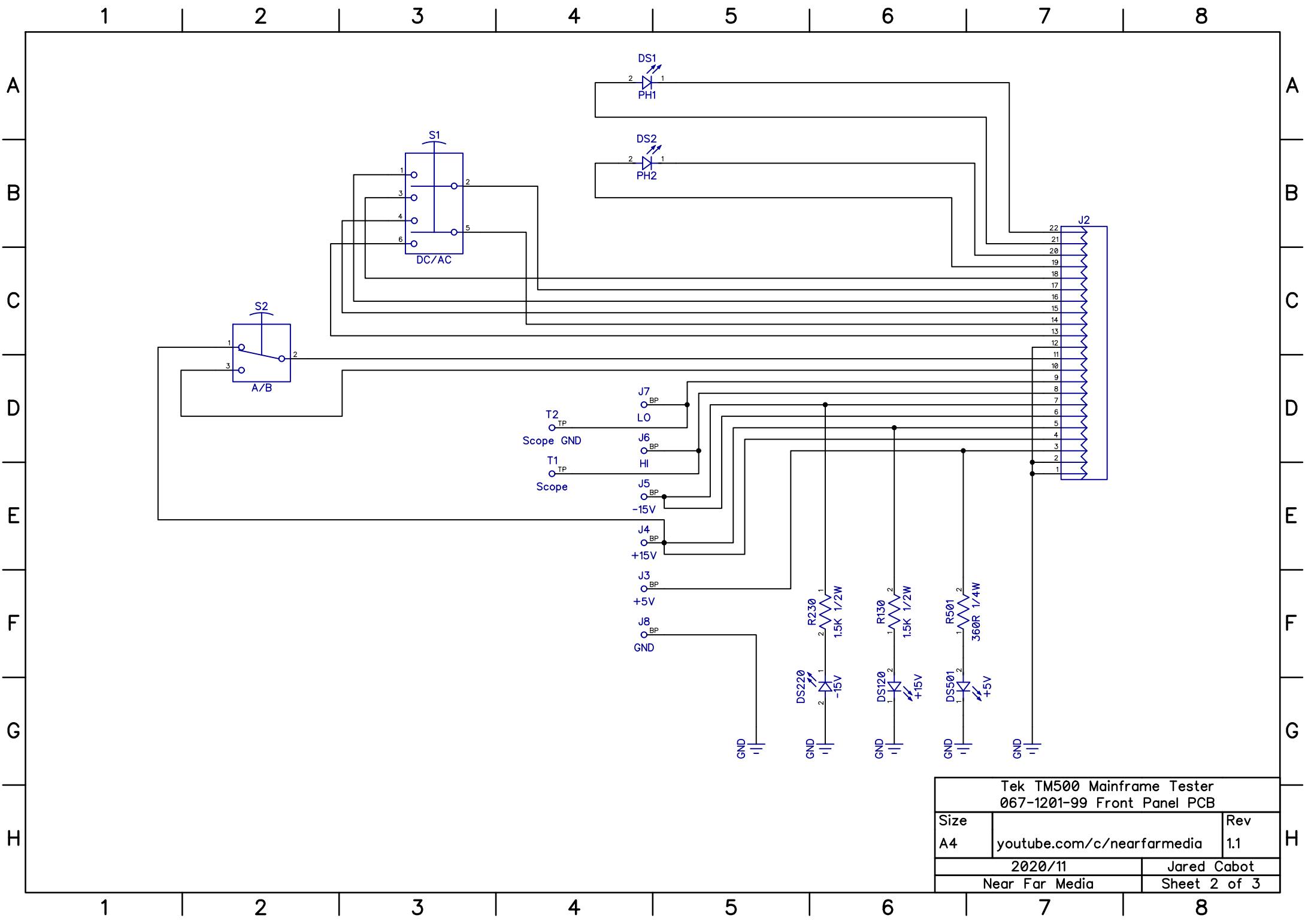

Tek TM500 Mainframe Tester		
067-1201-99 Front Panel PCB		
Size		Rev
A4	<a href="https://www.youtube.com/c/nearfarmedia">youtube.com/c/nearfarmedia</a>	1.1
2020/11		Jared Cabot
Near Far Media		Sheet 2 of 3

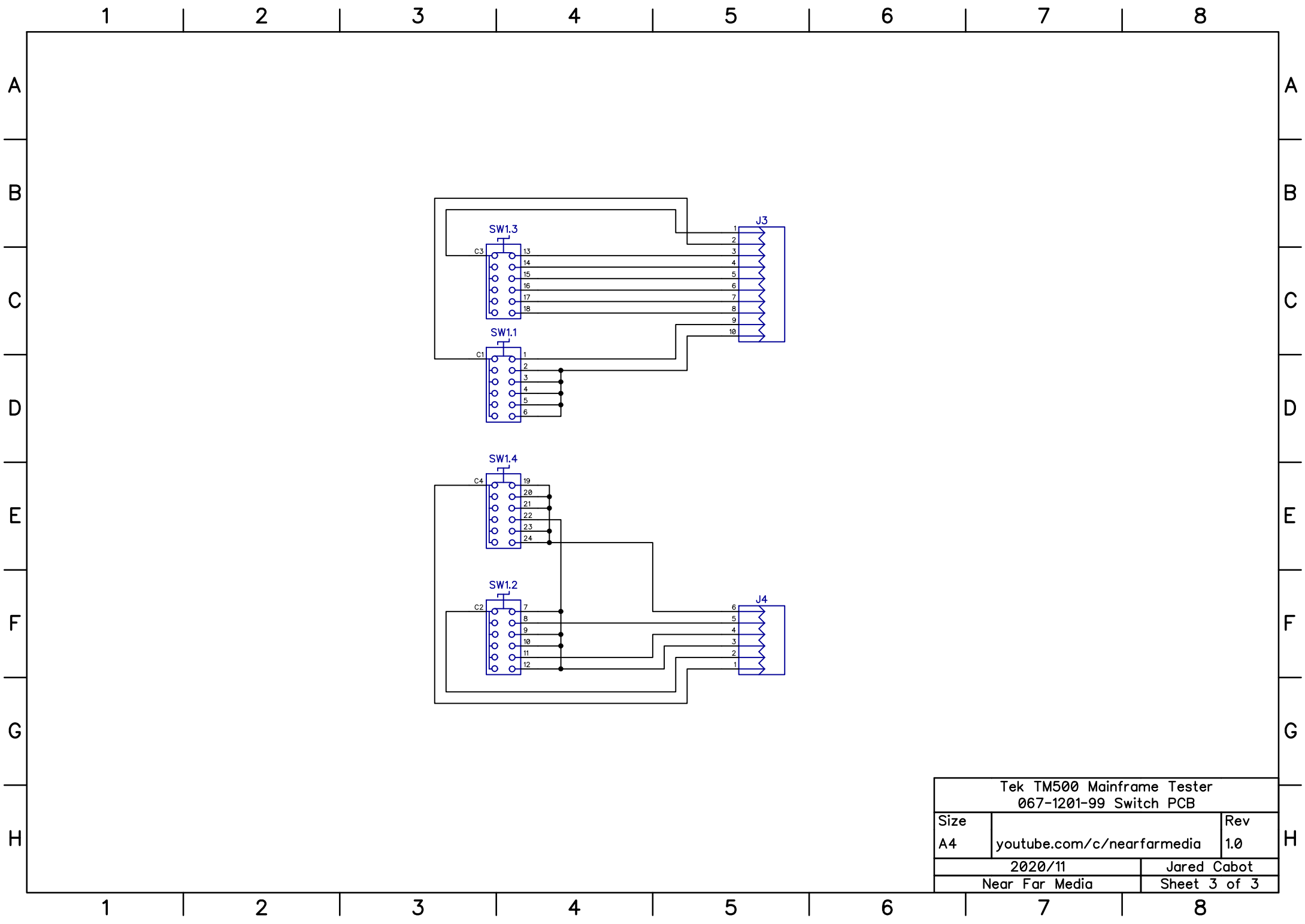

Tek TM500 Mainframe Tester		
067-1201-99 Switch PCB		
Size		Rev
A4	<a href="https://www.youtube.com/c/nearfarmedia">youtube.com/c/nearfarmedia</a>	1.0
2020/11		Jared Cabot
Near Far Media		Sheet 3 of 3

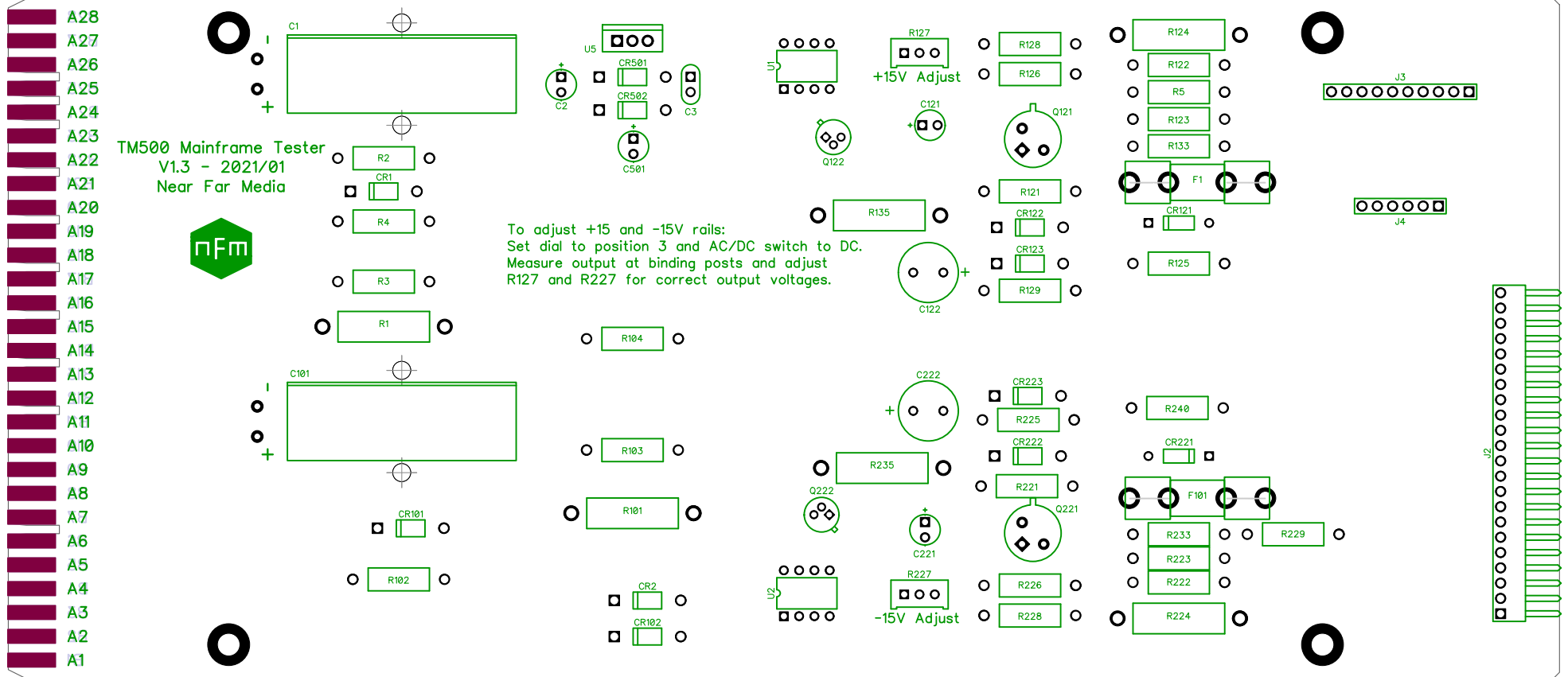

TM500 Mainframe Tester  
V1.3 - 2021/01  
Near Far Media



To adjust +15 and -15V rails:  
Set dial to position 3 and AC/DC switch to DC.  
Measure output at binding posts and adjust  
R127 and R227 for correct output voltages.

- A28
- A27
- A26
- A25
- A24
- A23
- A22
- A21
- A20
- A19
- A18
- A17
- A16
- A15
- A14
- A13
- A12
- A11
- A10
- A9
- A8
- A7
- A6
- A5
- A4
- A3
- A2
- A1

Tek TM500 Mainframe Tester 067-1201-99 Main PCB		
Size	<a href="https://youtube.com/c/nearfarmedia">youtube.com/c/nearfarmedia</a>	Rev
A4		1.3
2020/12		Jared Cabot
Near Far Media		Sheet 1 of 4

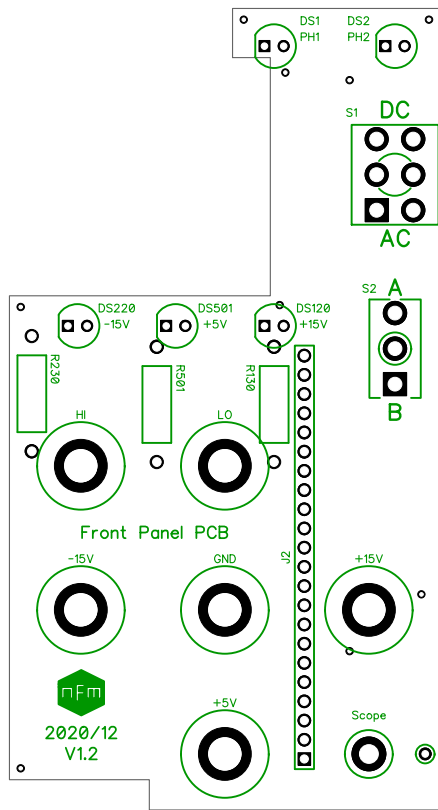

Tek TM500 Mainframe Tester 067-1201-99 Front Panel PCB		
Size		Rev
A4	<a href="https://www.youtube.com/c/nearfarmedia">youtube.com/c/nearfarmedia</a>	1.2
2020/12		Jared Cabot
Near Far Media		Sheet 2 of 4

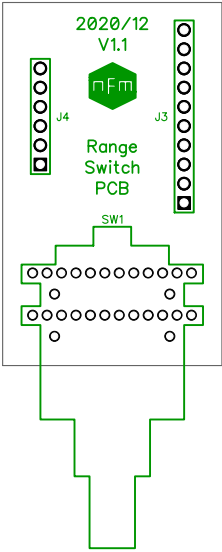

Tek TM500 Mainframe Tester 067-1201-99 Range Switch PCB		
Size		Rev
A4	<a href="https://www.youtube.com/c/nearfarmedia">youtube.com/c/nearfarmedia</a>	1.1
2020/12		Jared Cabot
Near Far Media		Sheet 3 of 4

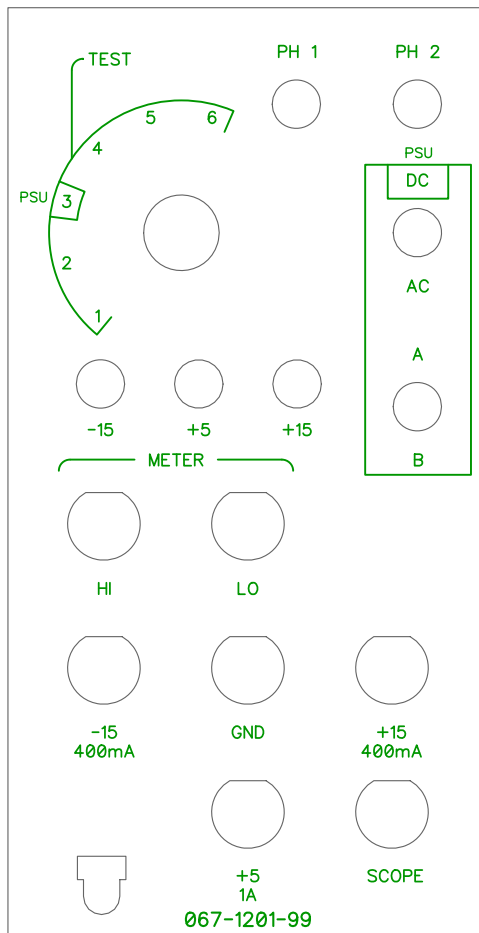

Tek TM500 Mainframe Tester 067-1201-99 Front Panel Layout		
Size		Rev
A4	<a href="https://www.youtube.com/c/nearfarmedia">youtube.com/c/nearfarmedia</a>	1.2
2020/12		Jared Cabot
Near Far Media		Sheet 4 of 4



# FRONT PANEL DRILL TEMPLATE

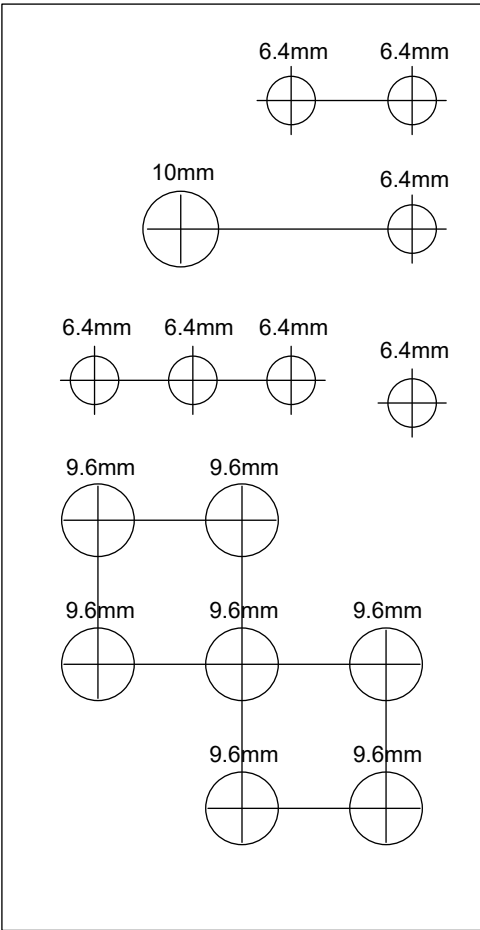

100mm

Print this page with Page Size set to 'Actual Size' or 100% scaling and check the scale to ensure correct sizing.



# INNER PANEL DRILL TEMPLATE

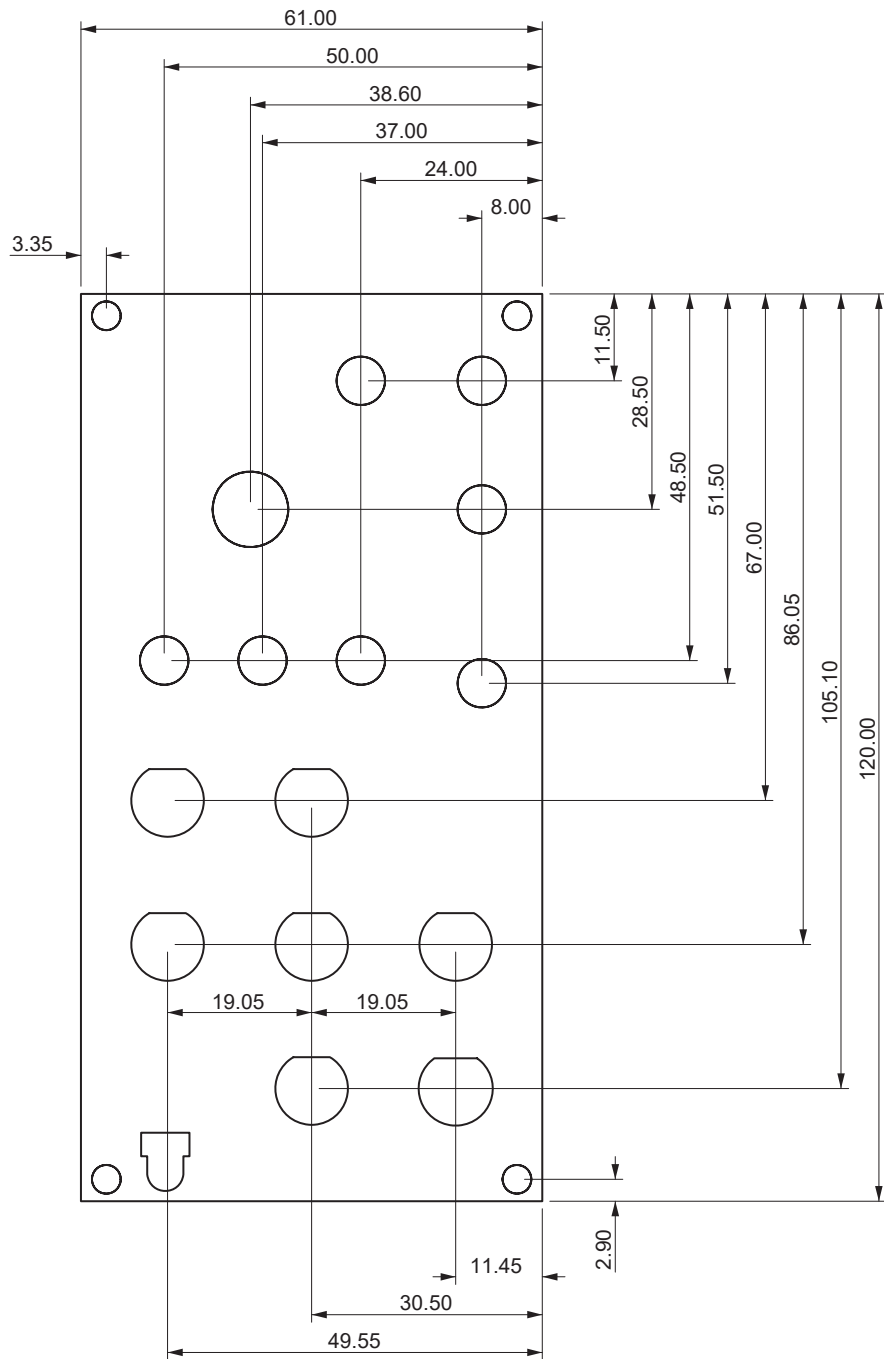

100mm

Print this page with Page Size set to 'Actual Size' or 100% scaling and check the scale to ensure correct sizing.

