

TEKTRONIX®

465

MOD UC

INSTRUCTION MANUAL

TEKTRONIX®

This insert is provided as a supplement to the instruction manual furnished with this modified instrument. The information given in this insert supersedes that given in the manual.

This insert material Copyright © 1978 by Tektronix, Inc., Beaverton, Oregon. Printed in the United States of America. All rights reserved. Contents of this insert may not be reproduced in any form without permission of the copyright owner.

465
MOD UC

MODIFICATION INSERT

TABLE OF CONTENTS

	Page		Page
INTRODUCTION	iii	DETAILED CIRCUIT DESCRIPTION	
OPERATING INSTRUCTIONS		Input and Track-Hold Amplifiers	15
CONTROLS AND INDICATORS	1	Analog-to-Digital Converter	15
BASIC DISPLAYS AND OPERATIONS	2	Memory and Digital-to-Analog Converter	15
Normal Sweep Display	2	Vertical Signal Multiplexing	15
Display Storage	2	VERTICAL DISPLAY POSITION and X5 MAG	15
Measuring Time on a Stored Waveform	3	Vertical Master Gain	17
Measuring Voltage on a Stored Waveform	3	Clock and Divide Chain	17
Comparing Two Waveforms	3	TIME/DIV X10	18
OPERATORS CHECKOUT PROCEDURE		Timing and Synchronization	18
Test Equipment Required	4	Record or Display Control	18
465 Oscilloscope Performance Check	4	Overlay Control	19
Preliminary Set Up	4	Horizontal Ramp	19
Procedures	5	DOT 1 and DOT 2 Generation	19
Check Vertical Gain	5	Z-Axis Signal	19
Check VOLTS Measurement Accuracy	5	CHOP Mode Vertical Switching	19
Check VERTICAL DISPLAY X5 MAG	5	LED Display	19
Check Horizontal Gain	5	SCALING	19
Check TIME Measurement Accuracy	6	UNCAL, DECIMAL POINT, AND SCALE	
Check UNCAL Light	6	FACTOR LIGHTS	20
Check Readout Decimal Point	6	Power Supply	20
		ADJUSTMENT PROCEDURE	
		Test Equipment Required	21
		465 Oscilloscope Calibration	21
		INDEX TO ADJUSTMENT PROCEDURE	21
		Preliminary Control Settings	21
		PROCEDURE	22
		MAINTENANCE	
THEORY OF OPERATION		MAINTENANCE PRECAUTIONS	26
BLOCK DIAGRAM DESCRIPTION		Static-Sensitive Components	26
Vertical Channel	8	OBTAINING REPLACEMENT PARTS	26
Horizontal	11	CABINET REMOVAL	27
Z-Axis	11	DISASSEMBLY PROCEDURES	29
Clock and Synchronizer	11	Mod UC-Oscilloscope Separation	29
Record or Display Control	12	Front Panel Removal	29
Scale and UNCAL Display	13	Readout Board Removal	30
Scaling, DVM, and LED Display	14	Main Board Removal	30
		Mod UC Power Supply Removal	30
		PREVENTIVE MAINTENANCE	30

WARNING

THE REMAINING PORTION OF THIS TABLE OF CONTENTS LISTS THE SERVICING INSTRUCTIONS. THESE SERVICING INSTRUCTIONS ARE FOR USE BY QUALIFIED PERSONNEL ONLY. TO AVOID PERSONAL INJURY, DO NOT PERFORM ANY SERVICING OTHER THAN THAT CALLED IN THE OPERATING INSTRUCTIONS UNLESS QUALIFIED TO DO SO.

TABLE OF CONTENTS (cont)

	Page		Page
TROUBLESHOOTING		REPLACEABLE ELECTRICAL PARTS	40
RECOMMENDED TEST EQUIPMENT	31	REPLACEABLE MECHANICAL PARTS	44
TROUBLESHOOTING AIDS	31	DIAGRAMS AND CIRCUIT BOARD	
Circuit Description	31	ILLUSTRATIONS	45
Diagrams	31		
Voltages and Waveforms	31		
Circuit Board Illustrations	31		
Troubleshooting Table	31		

LIST OF ILLUSTRATIONS

Figure No.	Page	Figure No.	Page
1	Location of the DIGITAL STORAGE Mod UC controls and indicators.	11	Scaling, DVM, LED display.
2	Input and Track-hold amplifiers.	12	Simplified vertical signal multiplexing circuit.
3	ADC and Memory.	13	Simplified VERTICAL DISPLAY POSITION circuit.
4	Vertical signal multiplexing.	14	Simplified VERTICAL X5 MAG circuit.
5	Vertical output.	15	ADC timing diagram.
6	Horizontal and Z-Axis output.	16	465 Mod UC cover removal.
7	Clock and Synchronizer.	17	Location of plugs and connectors.
8	Record or Display control.	18	Mod UC and Oscilloscope separation.
9	CH1 and CH 2 VOLTS/DIV switch position.	19	Mod UC power supply assembly removal.
10	VOLTS/DIV and TIME/DIV switch position decoding.		

INTRODUCTION

The Tektronix 465 DIGITAL STORAGE Mod UC is a 465 oscilloscope with an attached digital storage and display unit. It provides an easy-to-use means of storing and analyzing single-event waveshapes for voltage and time measurements. It also has the capability of storing two waveforms and displaying them together for making comparisons.

A waveform under test is sampled, converted to digital information and stored in the Mod UC semiconductor memory. Storage takes place when a sweep occurs while the 465 is operating in the SINGL SWP TRIG MODE and the STORED DISPLAY IN button is pushed fully in. The stored waveform remains displayed as long as the STORED DISPLAY IN button is fully in.

A choice of VOLTS, TIME, or OVERLAY FUNCTION is available. In the VOLTS FUNCTION, LINE 1 and LINE 2 controls position horizontal cursors at the amplitude points to be measured. The voltage difference between the cursors will be displayed on the LED readout. In the TIME FUNCTION, DOT 1 and DOT 2 controls position two bright dots at the desired points on the trace for time measurement. The time difference between the dots will be displayed on the LED readout. When the OVERLAY FUNCTION is selected, two stored waveforms may be compared. The last waveform stored may be positioned vertically, but not horizontally, in relation to the first waveform stored for overlaying the two displayed waveforms.

OPERATING INSTRUCTIONS

CONTROLS AND INDICATORS

Figure 1 shows the location of the DIGITAL STORAGE Mod UC controls and indicators. Circled numbers on the figure correspond to the following descriptions of the Mod UC controls and indicators.

- ① **VERTICAL DISPLAY POSITION**—Permits vertical positioning of the stored display. Used in the OVERLAY FUNCTION to position two stored waveforms over each other for making comparisons.
- ② **VERTICAL DISPLAY X5 MAG**—Magnifies the vertical display amplitude of the stored waveform by a factor of five.
- ③ **TIME/DIV X10**—Slows the recording rate of the Mod UC by a factor of ten to permit storage of low-frequency waveforms. For example, if the 465 TIME/DIV control is set to .1 s and the DIGITAL STORAGE TIME/DIV X10 is depressed, the sweep will be recorded at 1.0 s/DIV.
- ④ **FUNCTION**—Selects either the OVERLAY, VOLTS, or TIME FUNCTION.
- ⑤ **UNCAL**—Lights to warn the operator of a switch setting that may cause erroneous readings.
- ⑥ **Readout**—A 3½ digit LED display. Displays the voltage difference between the LINE 1 and LINE 2 cursor positions or the time difference between the DOT 1 and DOT 2 dot positions.
- ⑦ **Range and Function LEDs**—LEDs indicate either s (seconds) or ms (milliseconds) if the TIME FUNCTION is selected and either V (volts) or mV (millivolts) if the VOLTS FUNCTION is selected.
- ⑧ **LINE 1 or DOT 1 and LINE 2 or DOT 2**—Positions the voltage cursors if the VOLTS FUNCTION is selected and positions the dots if the TIME FUNCTION is selected.
- ⑨ **STORED DISPLAY IN**—A three-position switch. In the fully-in position it enables the 465 DIGITAL STORAGE Mod UC to store a waveform when the 465 SINGL SWP button is pushed. The stored waveform is then displayed. The center position (normal) allows full-bandwidth operation of the vertical amplifiers with a normal sweep display. In the fully-out position, the bandwidth of the vertical amplifiers is limited to 20 MHz.

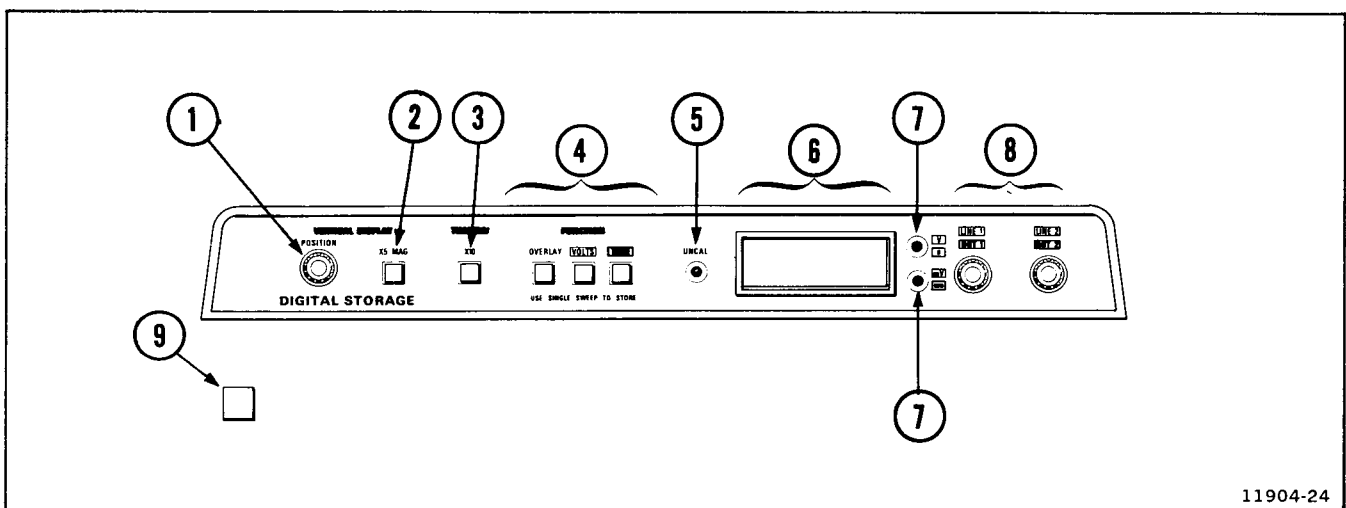

Figure 1. Location of the DIGITAL STORAGE Mod UC controls and indicators.

11904-24

BASIC DISPLAYS AND OPERATIONS

The following instructions will permit the operator to obtain commonly used basic displays, store displays, make time and voltage measurements, and compare waveforms.

Preliminary Control Settings

Vertical (CH 1 and CH 2 if applicable)

VERT MODE	CH 1
VOLTS/DIV	Setting determined by amplitude of signal to be applied.
VOLTS/DIV VAR	Calibrated detent
AC-GND-DC	DC
Vertical POSITION	Midrange
INVERT	Button out

Display

INTEN	Fully counterclockwise
FOCUS	Midrange
SCALE ILLUM	Midrange

Trigger

SLOPE	+
LEVEL	0
SOURCE	NORM
COUPLING	AC
TRIG MODE	AUTO
A TRIG HOLDOFF	NORM

Horizontal

TIME/DIV (A and B)	Locked together at 1 ms
A TIME/DIV VAR	Calibrated detent
HORIZ DISPLAY	A
X10 MAG (IN)	Off (button out)
Horizontal POSITION	Midrange

DIGITAL STORAGE

STORED DISPLAY IN	Normal (button in center position)
VERTICAL DISPLAY POSITION	Midrange
VERTICAL DISPLAY X5 MAG	Off (button out)
TIME/DIV X10 FUNCTION	As needed Determined by type of measurement to be made.

Normal Sweep Display

1. Connect the oscilloscope to an ac power source.
2. Pull the POWER switch on and allow several minutes for warmup.
3. Connect the external signal to the CH 1 input connector.
4. Adjust the INTENSITY control for desired display brightness. If the display is not visible with the INTENSITY control at midrange, press the BEAM FIND pushbutton and adjust the CH 1 VOLTS/DIV switch to reduce the vertical display size. Center the compressed display with the Vertical and Horizontal POSITION controls; release the BEAM FIND pushbutton. Adjust the FOCUS and ASTIG controls for a well-defined display. If necessary, adjust TRACE ROTATION so trace is parallel with horizontal graticule line.
5. Set the CH 1 VOLTS/DIV switch and Vertical POSITION control to locate the display within the graticule area.
6. Adjust the A Trigger LEVEL control for a stable display.
7. Set the A TIME/DIV switch and the Horizontal POSITION control to locate the display within the graticule area (0.5 s to 1 ms for storing a display with the Mod UC).

Display Storage

When storing a display, observe the UNCAL light. Several conditions that may cause inaccurate measurements will cause the UNCAL light to be on. These conditions are:

- a. The TIME/DIV control is in the X-Y position or is set to a sweep time of 0.5 ms or faster.
- b. The VOLTS/DIV VAR knob on the channel selected is out of calibrated detent.
- c. A dual channel VERT MODE (ALT, CHOP, or ADD) is selected, and one or both of the VOLTS/DIV VAR knobs are out of calibrated detent.

d. A dual-channel VERT MODE is selected, and the two VOLTS/DIV switches are set to different sensitivities.

e. A dual-channel VERT MODE is selected, and a 10X coded probe in use on only one channel.

1. Obtain an Normal Sweep Display.
2. Adjust the Trigger controls (COUPLING, SOURCE, SLOPE, and LEVEL) as needed to obtain a single sweep display.
3. Push the STORED DISPLAY IN button fully in.
4. Press the SINGL SWP button. When triggered, the single sweep will occur and the 465 DIGITAL STORAGE Mod UC will store the display.

NOTE

The 465 DIGITAL STORAGE Mod UC stores a waveform each time a single sweep occurs while the STORED DISPLAY IN button is depressed. It displays a waveform only when the STORED DISPLAY IN button is fully in.

Measuring Time on a Stored Waveform

1. Store a display.
2. Select the TIME FUNCTION on the Mod UC front panel.
3. Set the VERTICAL DISPLAY X5 MAG as desired.
4. Use the VERTICAL DISPLAY POSITION and the 465 Horizontal POSITION to move the waveform to the desired position.
5. Position the two dots, using the DOT 1 and DOT 2 controls, at the points on the stored waveform between which you wish to measure the time difference.
6. The readout will display the time difference between the two dots. The s (seconds) or ms (milliseconds) lamp will indicate the time units.

Measuring Voltage on a Stored Waveform

1. Store a display.
2. Select the VOLTS FUNCTION on the Mod UC front panel.
3. Set the VERTICAL DISPLAY X5 MAG as desired.
4. Use the VERTICAL DISPLAY POSITION to move the waveform to the desired position.
5. Position the horizontal cursors, using the LINE 1 and LINE 2 controls, at the amplitude points in the displayed waveform between which you wish to measure the voltage.
6. The readout will display the voltage difference between the points determined by the two horizontal cursor positions. The V (volts) or mV (millivolts) lamp will indicate the units.

NOTE

If you wish to obtain a zero reference for the stored display you must store a zero-volts display. Then adjust the DIGITAL STORAGE VERTICAL DISPLAY POSITION control so the zero-volts stored display coincides with the same horizontal graticule line as the zero-volts normal sweep display.

Comparing Two Waveforms

1. Store a display.
2. Store the waveform to be compared with the stored display.
3. Select the OVERLAY FUNCTION on the DIGITAL STORAGE front panel.
4. Use the VERTICAL DISPLAY POSITION control to vertically position the more recently stored waveform over the waveform stored in step 1.

NOTE

Horizontal displacement between the two waveforms is not provided. Time and voltage measurements cannot be made in the OVERLAY FUNCTION.

OPERATORS CHECKOUT PROCEDURE

This procedure allows the basic performance specifications to be checked without removing the instrument covers.

Display

INTEN	Fully counterclockwise
FOCUS	Midrange
SCALE ILLUM	Midrange

TEST EQUIPMENT REQUIRED

Equipment needed to perform each Checkout Procedure is listed at the beginning of the first procedure. Refer to Table 6-2 of the 465 Oscilloscope Instruction Manual for the required test equipment specifications.

Trigger

SLOPE	+
LEVEL	0
SOURCE	CH 2
COUPLING	AC
TRIG MODE	AUTO
A TRIG HOLDOFF	NORM

465 OSCILLOSCOPE PERFORMANCE CHECK

The 465 oscilloscope must be operating within its specifications before the Operators Checkout Procedure may be carried out on the 465 DIGITAL STORAGE Mod UC. To check out the operation of the 465 oscilloscope, set the STORED DISPLAY IN button to the center position and use the Performance Check procedures in Section 5 of the 465 manual. Because the 465 Mod UC does not have a Trigger View feature, omit step 5 of the TRIGGERS subsection of the 465 Performance Check. If it is determined that the 465 oscilloscope is operating normally, proceed with the Mod UC Operators Checkout.

Horizontal

HORIZ DISPLAY	A
TIME/DIV (A and B)	Locked together at 1 ms
A TIME/DIV VAR	Calibrated detent
X10 MAG (IN)	Off (button out)
Horizontal POSITION	Midrange

DIGITAL STORAGE

VERTICAL DISPLAY POSITION	Midrange
VERTICAL DISPLAY X5 MAG	Button out
TIME/DIV X10 FUNCTION	Button out
	Determined by type of measurement to be made.
STORED DISPLAY IN	Normal (button out)

PRELIMINARY CONTROL SETTINGS

Set the controls on the 465 Mod UC as follows:

Vertical

VOLTS/DIV (both)	1 V
VOLTS/DIV VAR (both)	Calibrated detent
Vertical POSITION	Midrange
AC-GND-DC (both)	DC
VERT MODE	CH 2
INVERT	Button out

Use the procedure in the Operating Instructions to obtain a normal sweep display. No signal input is required.

PROCEDURE

Equipment Required

- | | |
|-------------------------|------------------------------|
| 1. Amplitude Calibrator | 3. 50 Ω coaxial cable |
| 2. Time-Mark Generator | 4. 50 Ω termination |

1. Check Vertical Gain

- a. Connect a 50 Ω cable from the Amplitude Calibrator output to the 465 CH 2 input. Set the Amplitude Calibrator for a five-volt output. Do not use a termination.
- b. Center the trace and check for a vertical display of five divisions.
- c. Push the STORED DISPLAY IN button fully in.
- d. Select the TIME FUNCTION on the DIGITAL STORAGE front panel.
- e. Push the SINGL SWP button.
- f. Use the VERTICAL DISPLAY POSITION control to center the trace.
- g. Check for a vertical display of five divisions.

2. Check VOLTS Measurement Accuracy

- a. Select the VOLTS FUNCTION on the DIGITAL STORAGE front panel.
- b. Set the LINE 1 and LINE 2 controls to line up the horizontal voltage cursors with the positive and negative peaks of the stored display.
- c. Check for a digital readout of five volts ± 0.15 volts (4.85 to 5.15 volts).

3. Check VERTICAL DISPLAY X5 MAG

- a. Set the Amplitude Calibrator for a one-volt output.
- b. Push the SINGL SWP button. (Verify that the single sweep triggered. Adjust TRIGGER LEVEL if necessary.)

- c. Use the VERTICAL DISPLAY POSITION control to line up the top of the stored display with the center graticule line and check for a one-division vertical display.
- d. Push in the X5 MAG button (located on the DIGITAL STORAGE front panel).
- e. Check for a five-division vertical display.
- f. Return the X5 MAG button to the normal position.
- g. Disconnect the Amplitude Calibrator from the 465.

4. Check Horizontal Gain

- a. Connect a 50 Ω cable from the Time-Mark Generator output to a 50 Ω termination attached to the CH 2 input of the 465.
- b. Set the Time-Mark Generator for a 1 ms output.
- c. Select the TIME FUNCTION on the DIGITAL STORAGE front panel.
- d. Pull the STORED DISPLAY IN button to the center position.
- e. Set the TRIG MODE to AUTO. (Adjust TRIGGER LEVEL for a stable sweep.)
- f. Use the 465 Horizontal POSITION control to verify that the 1 ms markers line up with the vertical graticule lines.
- g. Push the STORED DISPLAY IN button fully in.
- h. Press the SINGL SWP button. (This stores the markers. Because of their narrow pulse width, the markers may not have been sampled at the maximum amplitude and may not be the same amplitude.)
- i. Verify that the 1 ms markers line up with the vertical graticule lines and that there is one marker per division.

5. Check TIME Measurement Accuracy

- a. Use the DOT 1 and DOT 2 controls to line up the time measurement dots with the peaks of the second and tenth markers (eight-division horizontal difference).
- b. Check for a readout display of 8 ms \pm 0.08 ms (7.92 to 8.08 ms).
- c. Disconnect the Time-Mark Generator from the 465 input.

6. Check UNCAL Light

- a. Set the VERT MODE to ADD.
- b. Turn CH 2 VOLTS/DIV VAR out of detent.
- c. Verify that the UNCAL light comes on.
- d. Return CH 2 VOLTS/DIV VAR to detent and verify that UNCAL light turns off.
- e. Turn CH 1 VOLTS/DIV VAR out of detent.
- f. Verify that UNCAL light comes on.
- g. Return CH 1 VOLTS/DIV VAR to detent and verify that UNCAL light turns off.
- h. Set CH 1 VOLTS/DIV to 2 V.
- i. Verify that UNCAL light comes on.
- j. Set CH 2 VOLTS/DIV to 2 V.
- k. Verify that UNCAL light turns off.
- l. Attach a 10X-coded probe to the CH 1 input.
- m. Verify that UNCAL light comes on.
- n. Remove 10X-coded probe from CH 1 input and verify that UNCAL light turns off.
- o. Attach a 10X-coded probe to the CH 2 input.
- p. Verify that UNCAL light comes on.
- q. Remove 10X-coded probe from CH 2 input and verify that UNCAL light turns off.
- r. Set the 465 TIME/DIV switch to .5 ms or faster.
- s. Verify that UNCAL light comes on at .5 ms and remains on as the TIME/DIV switch is turned to all faster sweep speeds.
- t. Set the 465 TIME/DIV switch to X-Y.
- u. Verify that UNCAL light comes on.

- v. Return TIME/DIV switch to 1 ms, one step at a time, and verify that UNCAL light does not come on as the TIME/DIV switch is turned from .5 s to 1 ms. The light may flicker but should not remain on.

7. Check Readout Decimal Point

The displays given in Table 1 depend on the dots being set as described in step 5. If the dots have been moved, set them eight horizontal divisions apart.

- a. Set the VERT MODE to CH 2.
- b. Set the Trigger SOURCE to LINE.
- c. Check the decimal point and multiplier light for the TIME/DIV settings given in Table 1 by selecting each TIME/DIV setting and pressing the SINGL SWP button to store the switch setting information in the Mod UC.

TABLE 1

TIME/DIV	Digital Display \pm 1%	s or ms light
1 ms	8.00	ms
5 ms	40.0	ms
20 ms	160.0	ms
50 ms	400	ms
.1 s	.800	s
TIME/DIV X10		
1 ms	80.0	ms
5 ms	400	ms
20 ms	1.600	s
50 ms	4.00	s
.1 s	8.00	s

NOTE

The display will take approximately 10 seconds to return on the last setting in Table 1.

- d. Select the VOLTS FUNCTION on the DIGITAL STORAGE front panel.
- e. Set the LINE 1 and LINE 2 controls for a six-division vertical difference between positions of the voltage measurement cursors.
- f. Set the TIME/DIV control to 1 ms.
- g. Check the decimal point and multiplier light for the VOLTS/DIV settings given in Table 2 by selecting each VOLTS/DIV setting and pressing the SINGL SWP button to store the switch setting information in the Mod UC.

TABLE 2

VOLTS/DIV	Digital Display	V or mV light
1 V	6.00	V
.1 V	.600	V
50 mV	300	mV
20 mV	120.0	mV
5 mV	30.0	mV

h. Set the VERT MODE to CH 1.

i. Repeat step 7, part g.

j. Connect a 10X coded probe to the CH 1 input connector. Do not connect the probe to an input signal source. The 10X coded probe is being used to activate the decimal-point-shift circuitry in the oscilloscope.

k. Check the decimal point and multiplier light for the VOLTS/DIV settings given in Table 3 by selecting each VOLTS/DIV setting and pressing the SINGL SWP button to store the switch setting information in the Mod UC.

TABLE 3

VOLTS/DIV	Digital Display	V or mV light
10 V	60.0	V
1 V	6.00	V
0.2 V	1.200	V
0.1 V	.600	V
50 mV	300	mV

l. Move the 10X coded probe to the CH 2 input.

m. Set the VERT MODE to CH 2.

n. Repeat step 7, part k.

This concludes the Operators Checkout Procedure.

THEORY OF OPERATION

This section contains a description of the circuitry in the DIGITAL STORAGE Mod UC. The description begins with a discussion of the Mod UC using the Block Diagram in the Diagrams section to show the basic interconnections between each major function. Each major function is explained with detailed block diagrams in the following discussion. Each circuit is then described in detail in the Detailed Circuit Description.

BLOCK DIAGRAM DESCRIPTION

Vertical Channel

The input amplifier U978 of the Mod UC provides a gain of 35 and isolates the oscilloscope COMP trigger circuit from the Mod UC input. The amplifier is turned on and off by the INOFF signal from S338B, the STORED DISPLAY

IN pushbutton switch. Q916 supplies an adjustable offset current. The output of the track-hold amplifier U977 tracks the input signal until a LO is applied to pin 8, then the output will be the charge on the memory capacitor C923. (See Figure 2.)

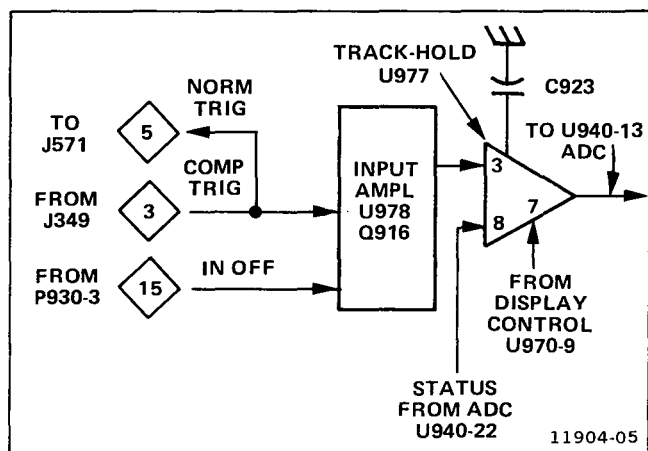

Figure 2. Input and Track-hold amplifiers.

U940 is a 10-bit successive-approximation analog-to-digital converter (adc). (See Figure 3.) It changes the sample voltage to a current and compares the current to 10 different reference current levels. The digital output will represent the sum of all the reference currents used to equal the input current. DB₀-DB₇ lines are buffered by U942, which isolates the adc from the memory during display time.

The semiconductor memory is a 1024-word memory divided into two 512-word halves. The halves are used to store two different waveforms for display during the OVERLAY FUNCTION. During display time U944, a digit-to-analog converter (dac), changes the digital information back to a current to obtain the vertical signal.

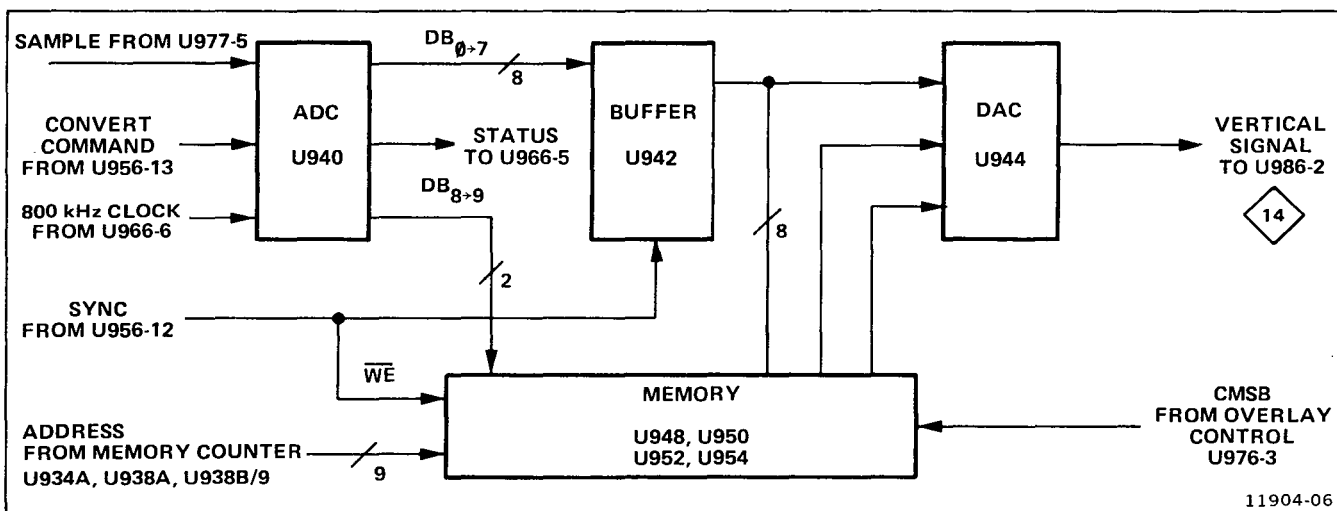

Figure 3. ADC and Memory.

See Figure 4. U986 changes the current output from the dac back into a voltage and provides vertical signal gain. In the VOLTS FUNCTION, the vertical signal multiplexer (mux) combines the vertical signal with the LINE 1 and LINE 2 voltages. The combined signal will display on the 465 crt as the vertical signal and two horizontal voltage cursors (lines).

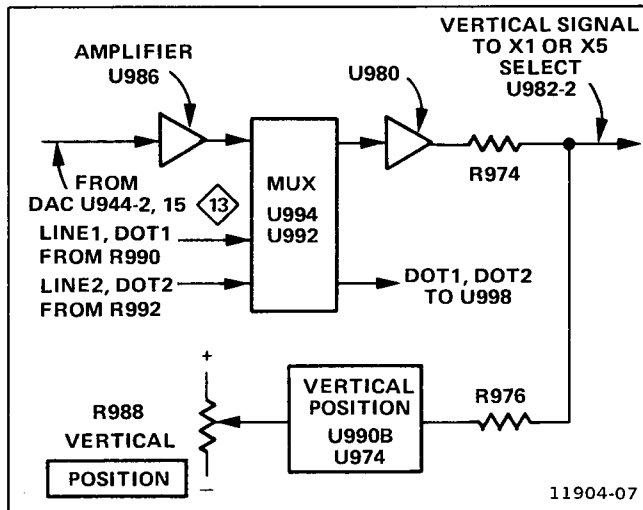

Figure 4. Vertical signal multiplexing.

U980 buffers the output of the vertical signal mux and R974 changes the voltage output back into a current. The current is summed with the output current from the vertical display position circuit to produce the total vertical offset. The summed currents will determine the vertical position of the trace on the 465 crt.

See Figure 5. U982 is a summing amplifier, and working with U988 it provides a vertical signal that changes in amplitude for the X1 or X5 MAG vertical display. When the VERTICAL DISPLAY X5 MAG button is in, U988 connects R978 across the summing amplifier. In the X1 position of the X5 MAG button, R977 is connected across the summing amplifier. The resistance ratio of the two resistors (R977 and R978) is five-to-one therefore a gain change of five is produced in the summing amplifier's gain by switching the resistors.

U984 is a buffer amplifier and resistors R983 and R982 set the vertical output gain of the Mod UC. Q984B is an emitter follower used for impedance matching. The vertical signal is fed to Q672 and Q682 in the 465 to be amplified for display on the crt. Q984A provides a thermally compensated reference voltage to be used in a display centering circuit.

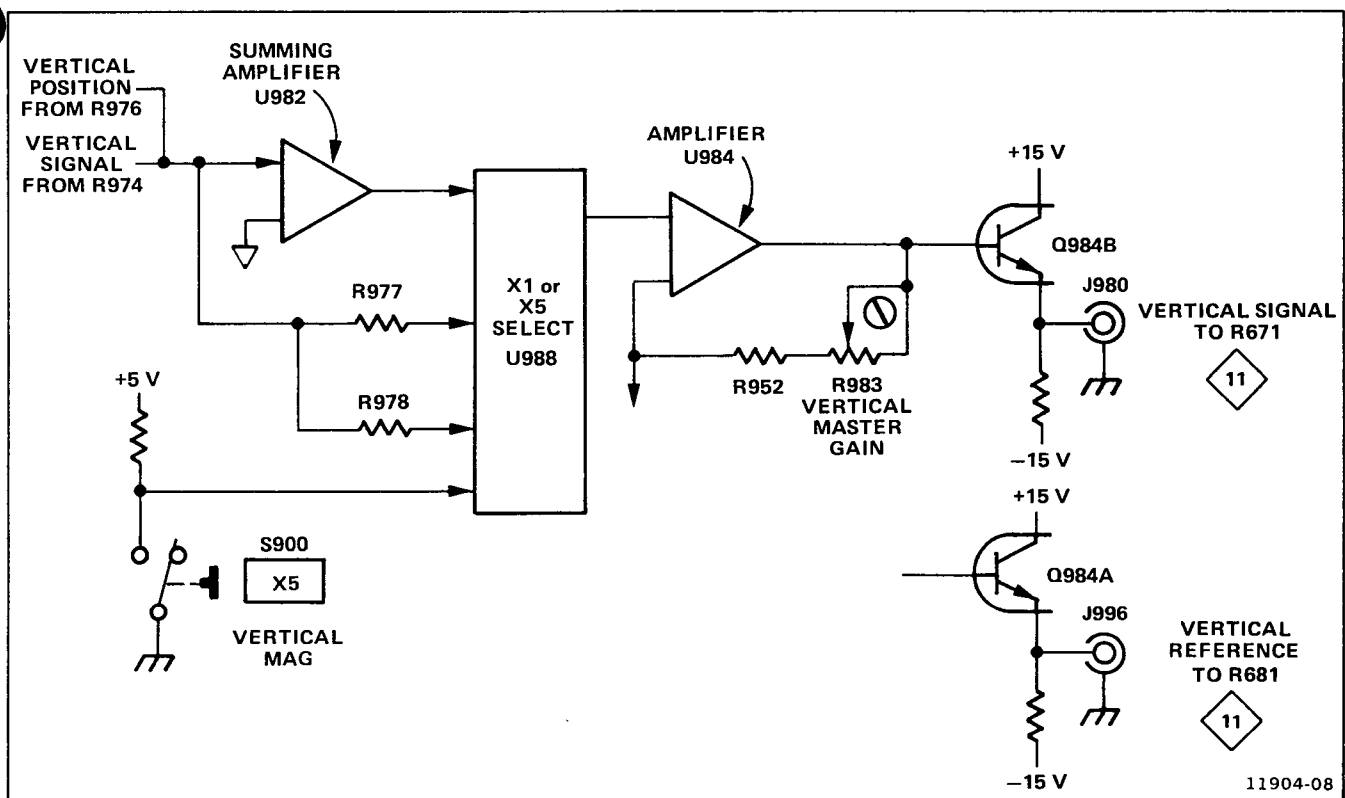

Figure 5. Vertical output.

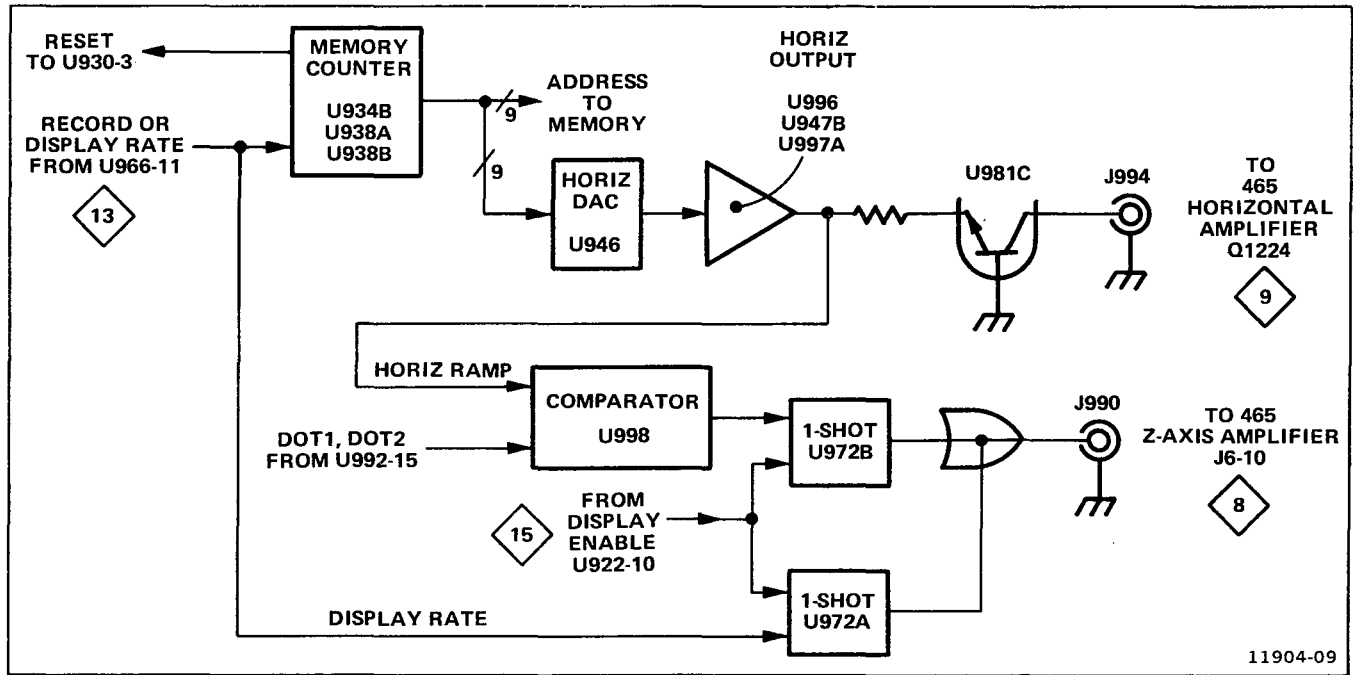

Figure 6. Horizontal and Z-Axis output.

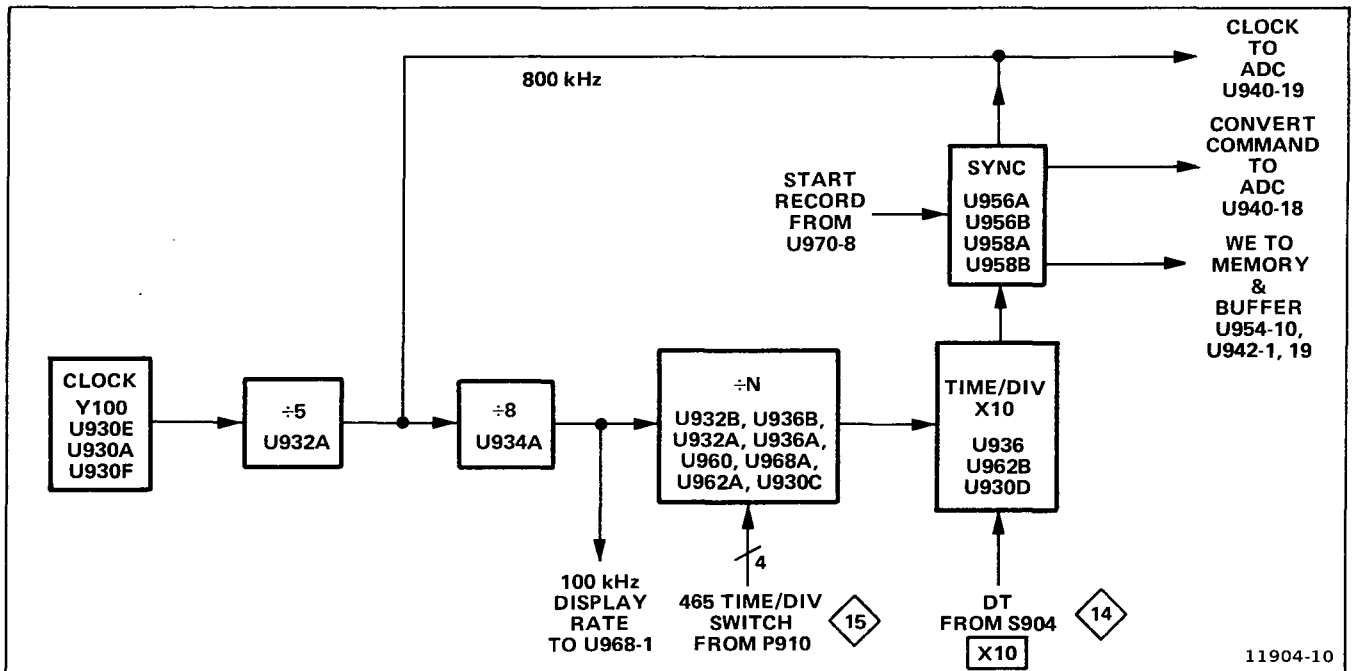

Figure 7. Clock and Synchronizer.

Horizontal (Figure 6)

The memory counter increments the memory address once while each data word is being stored or retrieved from memory for display. The output of the memory counter is proportional to the horizontal displacement of the waveform being displayed. U946 is a digital-to-analog converter that converts the digital contents of the memory counter to a current that increases as the counter is incremented. The horizontal output section converts the current to a voltage and generates a ramp used for the horizontal signal to the 465.

Z-Axis (Figure 6)

A ramp voltage is also sent to U998, a comparator which compares the ramp with the DOT 1 and DOT 2 voltages. When the ramp crosses the level of the DOT 1 or DOT 2 voltage, U988 switches and causes one-shot U972A to trigger. DOT 1 and DOT 2 voltages are multiplexed so two bright spots will appear on the crt when the TIME FUNCTION of the Mod UC is selected. The dots that produce the displayed trace on the 465 crt are generated by one-shot U972B. U972B triggers on the display rate waveform trailing edge.

Clock and Synchronizer (Figure 7)

Y100, U930A, U930E, and U930F form a crystal-controlled 4 MHz oscillator. The output is divided by five to produce the 800 kHz clock frequency to the adc. This frequency is divided by eight to obtain the 100 kHz display rate frequency. The $\div N$ circuitry produces an output frequency that depends on the setting of the 465 TIME/DIV switch setting. The selected frequency is fed to the TIME/DIV X10 circuit where it is allowed to pass directly through or is divided by ten, depending on the setting of the TIME/DIV X10 button on the Mod UC front panel. The output of the TIME/DIV X10 circuit is the record rate frequency. The sync circuit provides the necessary timing to control the memory, the adc, and enable data from the adc buffer U942 during a record cycle.

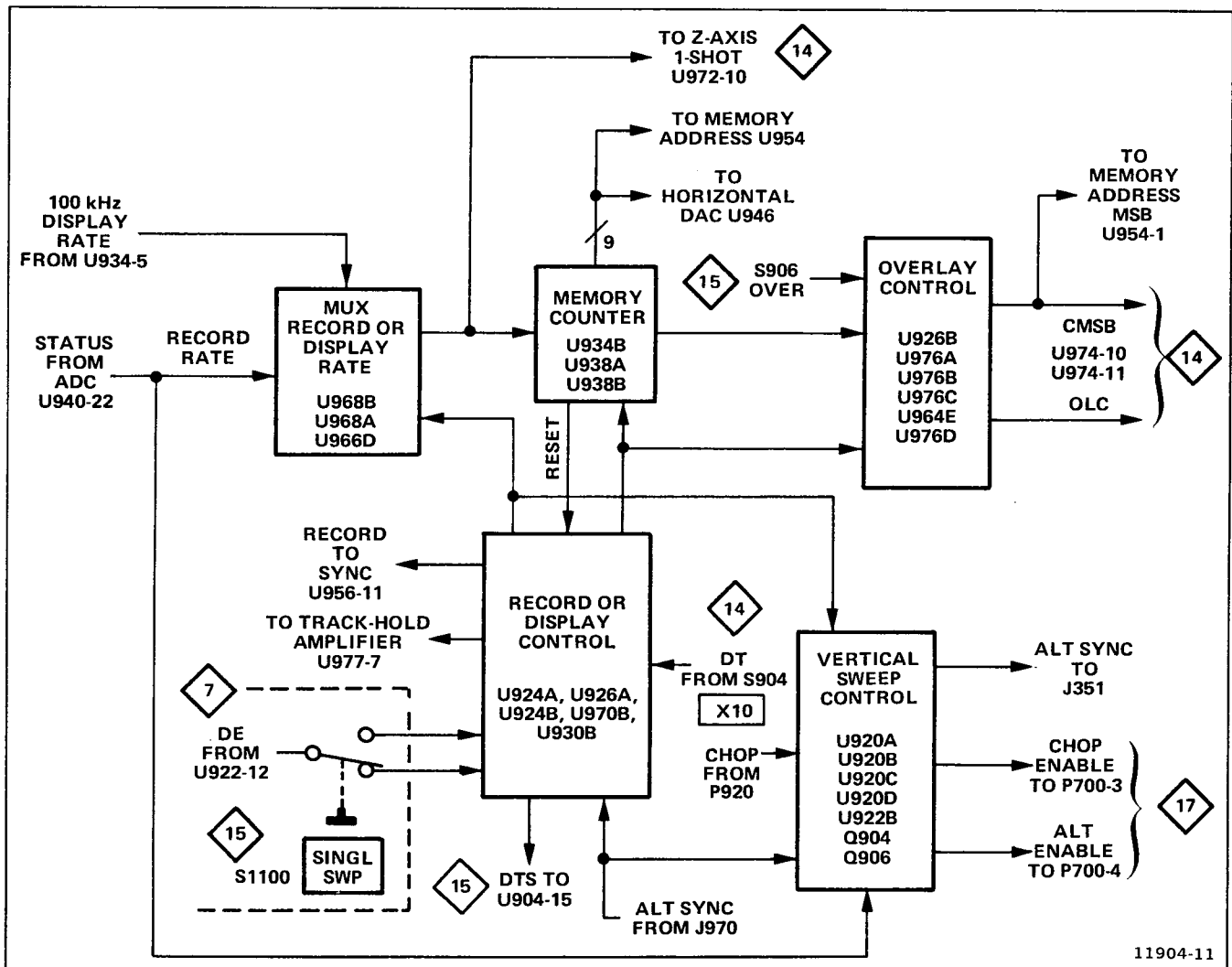

Figure 8. Record or Display control.

Record or Display Control (Figure 8)

U968B, U966D, and U968A make up the switching circuit that selects either the record or display rate to increment the memory counter. The record or display control is set in the record mode by the SINGL SWP button on the 465. In the set condition, an ALT SYNC signal received from the 465 will start the Mod UC recording. After 512 conversions by the adc, the memory counter sends a reset signal to the record or display control circuit to switch it to the display mode.

The vertical sweep control circuitry takes over the 465 Vertical channel switching when recording is done in the CHOP mode. The ALT SYNC is enabled and the display will alternate between CH 1 and CH 2 at the recording rate. Both channels will be recorded on the same half of memory.

The most significant bit of the memory address is controlled by U926B (in the overlay control circuitry). Since U926B changes state every recording cycle, the data is alternately directed into the upper or lower half of memory. During the display time, when the OVERLAY FUNCTION is selected, gating allows the memory counter to alternately select each half of the memory. The contents of one half of the memory will be displayed on one sweep and the contents of the other half of memory will be displayed on the next sweep. When the OVERLAY FUNCTION is not selected, the gating is not enabled and the contents of the last half of memory that was recorded will be displayed.

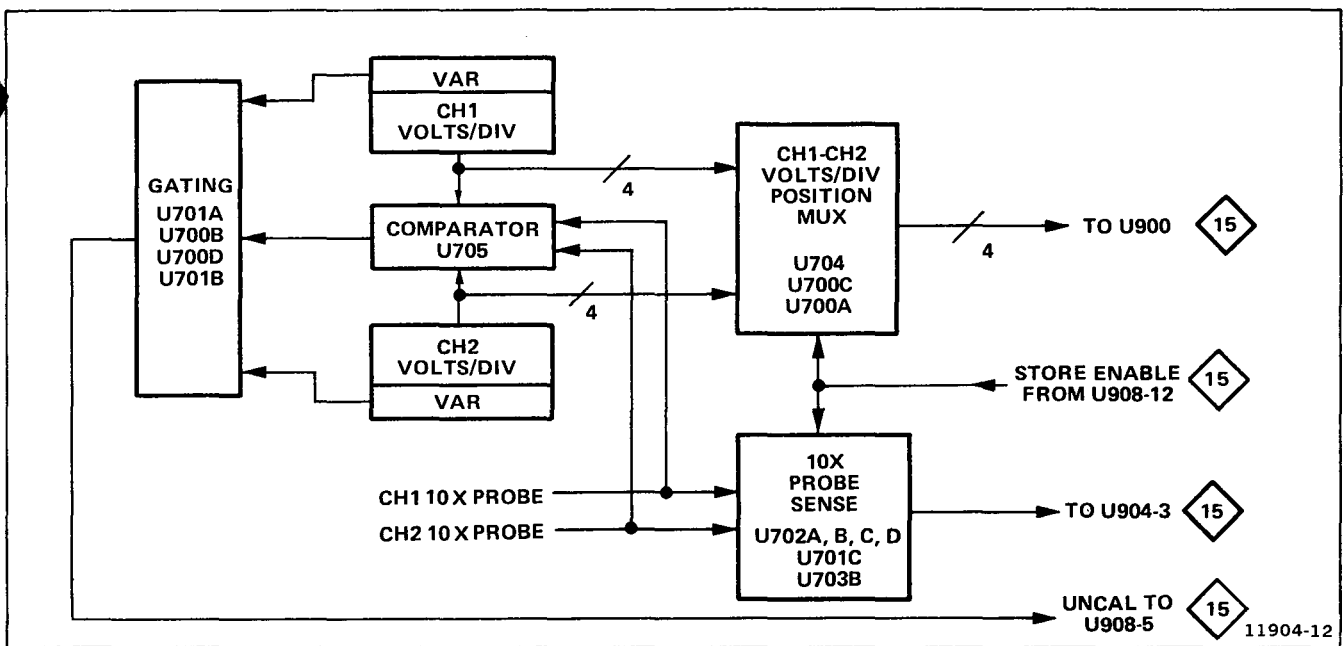

Figure 9. CH 1 and CH 2 VOLTS/DIV switch position comparator.

Scale and UNCAL Display

When the 465 is in a dual channel mode (ADD, CHOP, or ALT), comparator U705 compares the setting of the CH 1 VOLTS/DIV switch with the setting of the CH 2 VOLTS/DIV switch. If the settings are different the gating will be enabled to turn on the UNCAL light. If a 10X-coded probe is used on only one channel when the 465 is in a dual channel mode, the UNCAL light will remain on for any setting of the VOLTS/DIV VAR control on either channel is not in the calibrated

detent the gating will be enabled to turn on the UNCAL light. (See Figure 9.)

The CH 1 and CH 2 VOLTS/DIV switch position information is multiplexed by U704 to be sent to U900. (See Figure 10.) U900 stores the CH 1 and CH 2 VOLTS/DIV switch position information for use in setting the range of the LED display. U902 is a multiplexer that is controlled by the TIME and VOLTS FUNCTION switches of the Mod UC. When in TIME the TIME/DIV switch setting information from the 465 is sent to the switch-position-decoder

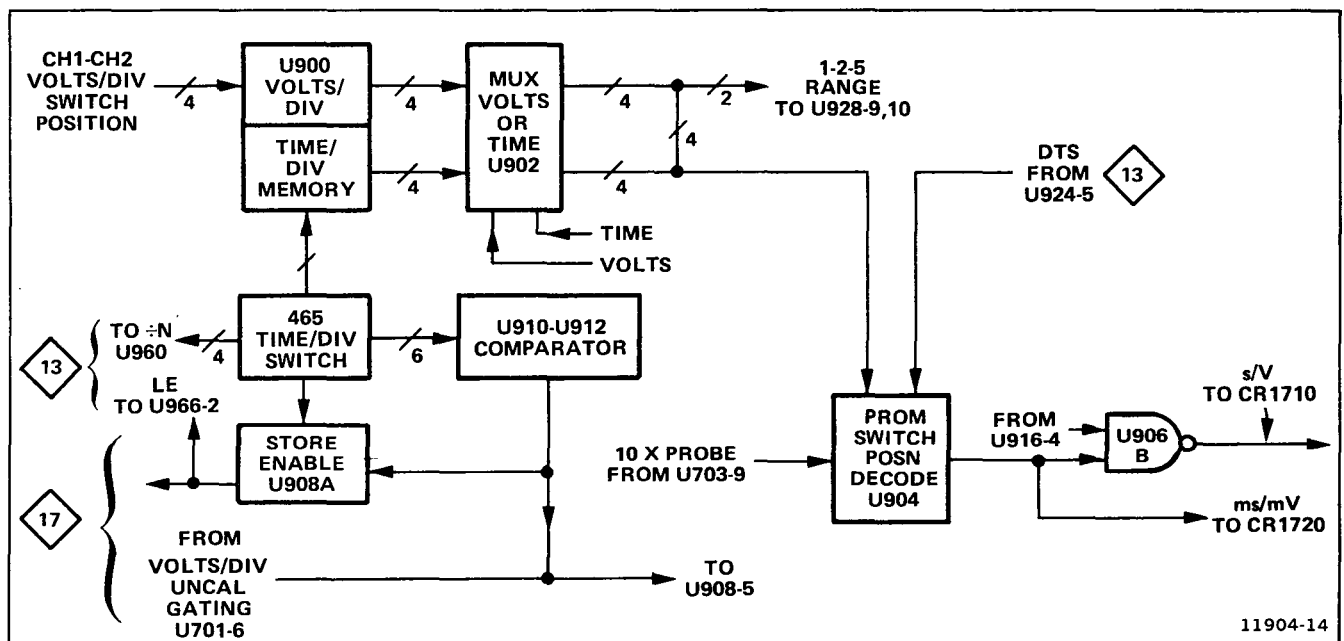

Figure 10. VOLTS/DIV and TIME/DIV switch position decoding.

PROM U904. The DTS signal input changes the scale by a factor of 10, depending on the setting of the TIME/DIV X10 button on the Mod UC front panel. U910 The decoded information selects the s or ms light as required. U910 and U912 compare the setting of the TIME/DIV switch of the 465 to a given set of conditions. TIME/DIV switch settings of X-Y and 0.5 ms or faster will cause the UNCAL light to turn on.

When the VOLTS FUNCTION is selected, the multiplexed CH 1 and CH 2 VOLTS/DIV switch setting information is sent to the switch-position-decoder PROM U904. The decoded information selects the mV or V light, depending on the setting of the VOLTS/DIV switches and the type of probe being used. A 10X-coded probe that activates the scale-factor-switch circuitry will also change the output of U904 to reflect the scale factor change. U904 also decodes the switch setting information when a single channel mode is used.

Scaling, DVM, and LED Display (Figure 11)

The LINE 1 or DOT 1 and LINE 2 or DOT 2 potentiometers produce a voltage that is proportional to their setting. The output voltage is amplified and fed to the scaling mux. The 1-2-5 range information from U902 switches the multiplexer to the correct scale so that the dvm will receive a voltage that is as near as possible to a full-scale value. The LINE 2 or DOT 2 voltage level is the analog common to the dvm, and the reference voltage required for the operation of the dvm floats on top of the common. The voltage reading produced by the dvm will then be the difference between the LINE 1 and LINE 2 voltages or the DOT 1 and DOT 2 voltages, and not an absolute value from a specific reference.

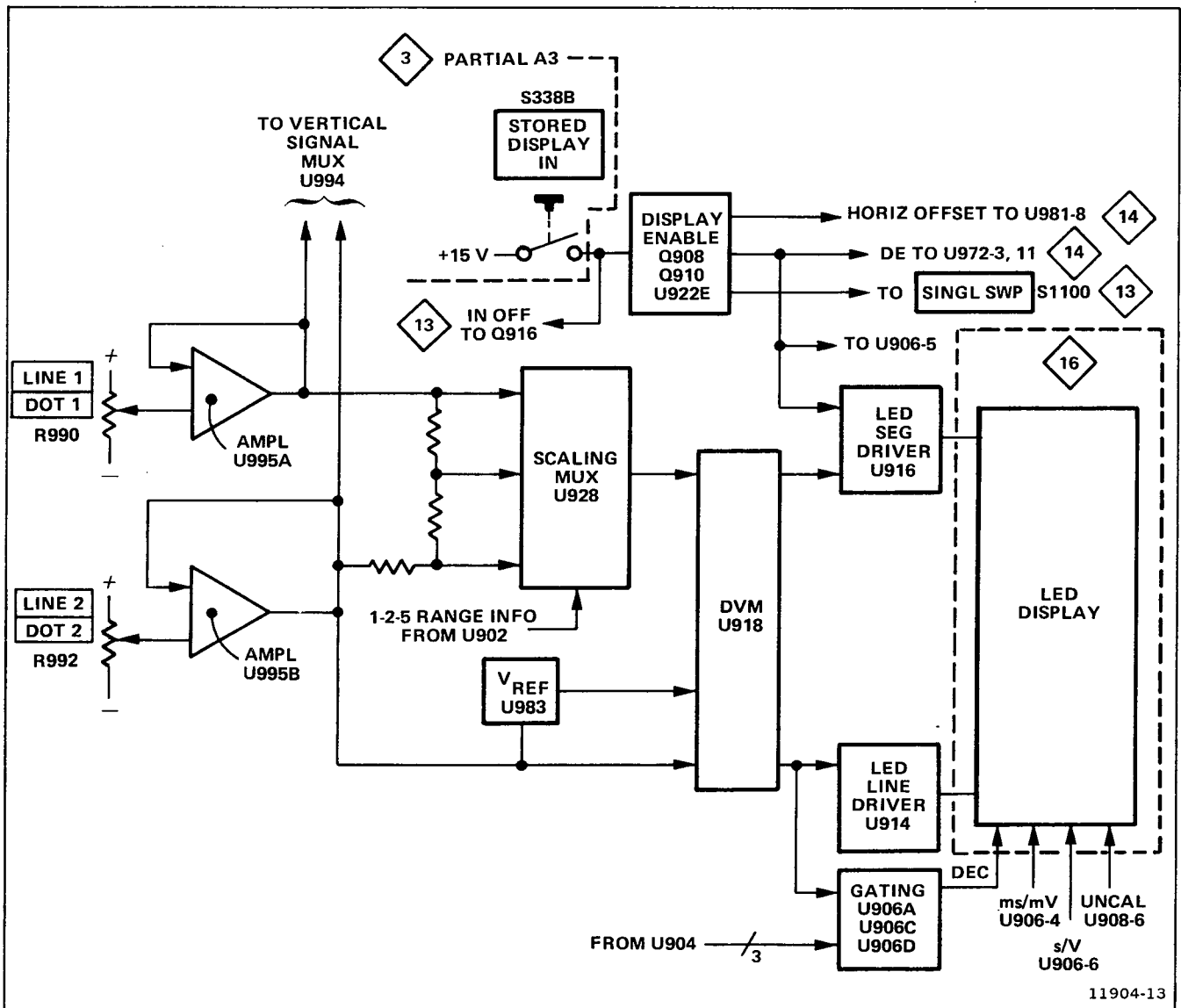

Figure 11. Scaling, DVM, and LED display.

The outputs of the dvm are fed to the LED display drivers where the correct segments and lines are enabled to light the display. The scale and UNCAL LEDs are activated by the circuit discussed previously. The decimal point LED is selected by gating that receives inputs from the dvm and the switch-position-decoding PROM.

DETAILED CIRCUIT DESCRIPTION

Input and Track-Hold Amplifiers 13

The input signal comes to the 465 DIGITAL STORAGE Mod UC from the Vertical Preamp circuit board of the 465. R745 isolates the oscilloscope from the input amplifier U978. The gain of the input amplifier is set to approximately 35 by R967, R966, and R964. R963 and RT963 provide thermal gain compensation for the circuit. The INOFF signal controls current source transistor Q916, whose output controls the offset of U978. When the STORED DISPLAY IN button on the 465 is fully in, +15 volts is applied to R973 to turn on Q916. When the STORED DISPLAY IN button is in either of its other two positions, the -15 volts on the lower end of R971 reverse-biases Q916. The emitter goes low enough to allow CR972 to conduct and clamp the emitter at -5 volts. CR973 will also conduct and the forward drop across the diode will ensure that Q916 is cut off.

The output of U978 is fed to U977, a track-hold amplifier. When pin 7 of U977 is LO and pin 8 is HI, the output of U977 tracks the input signal. The voltage that is present on the input pin 3 when a LO is applied to pin 8 will be held on the memory capacitor C923. This voltage level is the sample to be converted by the analog-to-digital converter (adc).

Analog-to-Digital Converter 13

U940 is a 10-bit successive-approximation analog-to-digital converter. It contains the digital and analog circuitry necessary to convert an analog input sample to a parallel binary output. External clocking is used to obtain the high conversion rate necessary for proper sampling of the waveform to be stored.

Memory and Digital-to-Analog Converter 13

The adc output lines DB_0 - DB_9 , are fed into the memory ICs U948, U950, U952, and U954. DB_0 - DB_7 are routed through U942, a three-state buffer. Because U952 and U954 have common input and output pins for the data transfer, U940 has to be isolated from the data bus when the stored waveform is retrieved from memory to be displayed. U942 provides the necessary isolation. U948 and U950 have separate input and output pins so no buffer is necessary.

During display, the output from the memory is fed into the digital-to-analog converter (dac) U944. The dac converts its digital input to a current at the output pin. U986 changes this current into a voltage that is proportional to the current. R977 and R999 set the gain of U986.

Vertical Signal Multiplexing 14

In the VOLTS FUNCTION, a HI on the V/\bar{T} line will cause U992 to select its AY input to be passed onto U980. A sequence of four signals is presented to the AY input of U992 from the X output of U994. They are:

1. The vertical signal from U986;
2. The LINE 1 voltage;
3. The vertical signal again;
4. The LINE 2 voltage.

This sequence is repeated as the vertical signal and two horizontal voltage cursors are displayed on the 465 crt.

In the TIME FUNCTION, a LO on the V/\bar{T} line will cause multiplexer U992 to connect the vertical signal at its AX input to output pin 14. The LINE 1 and LINE 2 voltages will not be multiplexed with the vertical signal. U992 will now be selecting the BX input to pass to its BX/BY output. The BX input is the DOT 1 and DOT 2 voltages that go to comparator U998. The TIME FUNCTION multiplexing is explained in the DOT 1 and DOT 2 Generation description.

U971A and U971B form a two-bit counter that drives the multiplexers and they are incremented at the beginning of every sweep. When the OVERLAY FUNCTION is selected, a LO on the OVER line resets both flip-flops. Their Q outputs switch to LO and multiplexer U994 stops. The vertical signal that is fed to U992 on its AX input is passed to the AX/AY output. See Figure 12 for a simplified diagram of the vertical signal multiplexing.

VERTICAL DISPLAY POSITION and X5 MAG

14

The multiplexed vertical information is fed to U980, a high-input-impedance buffer amplifier. R974 converts the vertical voltage signal to a current at the summing node (pin 2) of U982. U982 has two functions:

1. It sums the position offset currents to obtain the total vertical-position offset.
2. It produces a gain of either 1/4 or 5/4 for the X1 or X5 vertical magnification.

The VERTICAL DISPLAY POSITION CONTROL R988 is connected between the plus and minus one-volt reference supplies. R988 produces a displacement voltage that is buffered by U990B and applied to U974. U974 functions as two spdt switches, as shown in the simplified diagram in Figure 13. When both switches are in the X position, or when both switches are in the Y position, the signal on the BX/BY pin is passed to the output AX/AY. If the two switches are in different positions, no signal is transferred to the output and R986 will keep the input of U990 at ground potential.

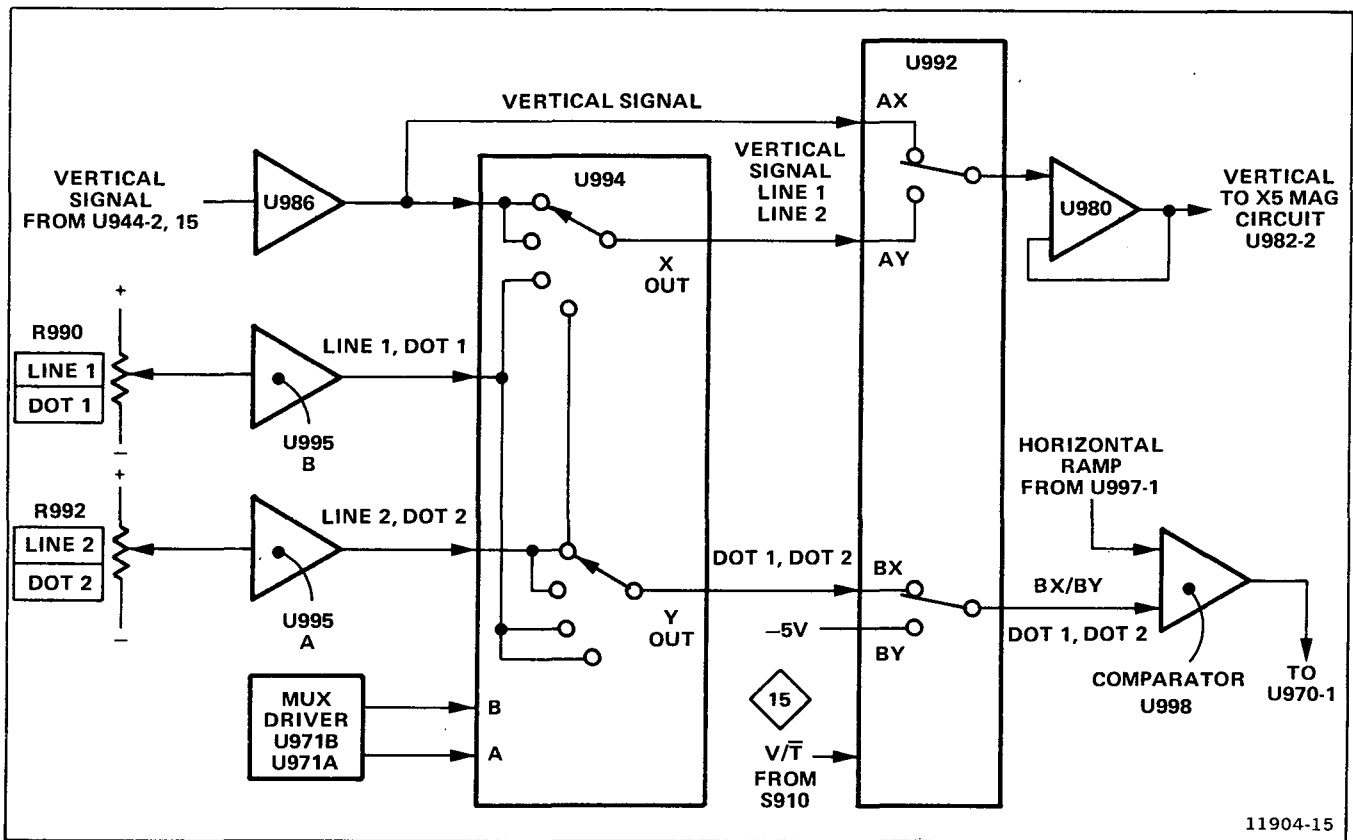

Figure 12. Simplified vertical signal multiplexing circuit.

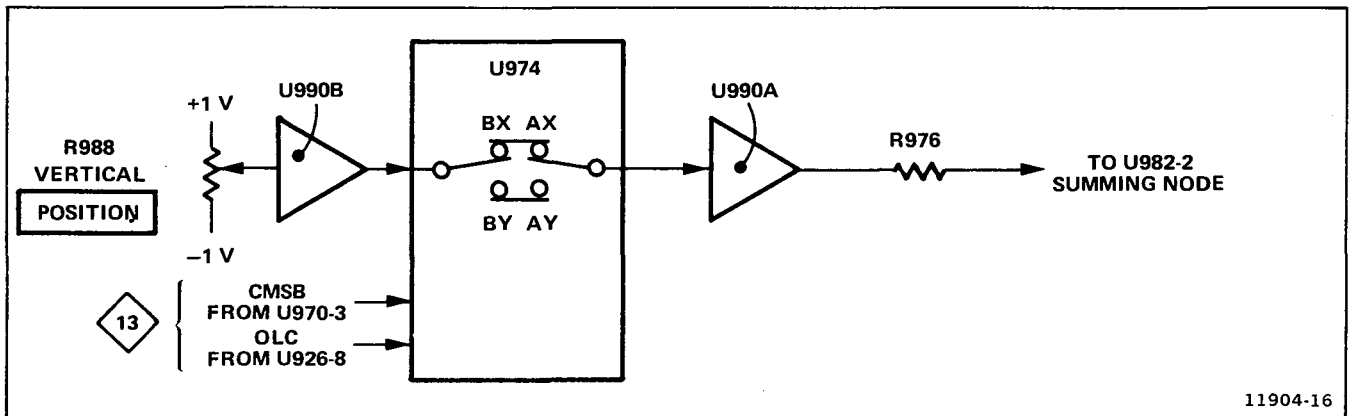

Figure 13. Simplified VERTICAL DISPLAY POSITION circuit.

The OLC signal from U926B controls the A switch and the CSMB signal from U976A controls the B switch. When the OVERLAY FUNCTION is selected, the switching will allow the VERTICAL DISPLAY POSITION control to position the last stored waveform. In either the TIME FUNCTION or VOLTS FUNCTION the switching will allow vertical positioning of the entire display. R976 converts the position-control voltage into a current at the summing node (pin 2) of U982.

U982, U988, R977, and R978 combine with the VERTICAL DISPLAY X5 MAG switch S900 to provide a gain change of five (see Figure 14). In the normal position of S900 (out), U988 connects R977 across U982 to set a gain of 1/4. When the X5 MAG button is in, R978 is connected across U982 to set a gain of 5/4. In either position of S900, the output of U982 is connected to the input of U984.

Vertical Master Gain 14

U984 buffers the output of U988 and with R980 and R983 sets the vertical output gain of the Mod UC. Temperature compensation of the amplifier's gain is provided by R987 and RT987. The output of U984 connects via R984 to the base of Q984B. R985 forms a voltage divider with R984 to set the input signal level of Q984B to the correct level. The network consisting of R989, C989, R991, and C991 frequency compensates the vertical output circuit. Q984B drives the Vertical Preamp in the 465, and Q984A provides a thermally-balanced reference for use in a display-centering circuit.

Clock and Divide Chain 13

Y900, U930E, U930F, R955, R956, C906, and C907 form a 4 MHz oscillator. U930A buffers the output of the oscillator and delivers the signal to flip-flop U932A. The B section of U932A divides the 4 MHz by five to produce 800 kHz. This 800 kHz signal is fed to the divide chain and the sync circuit. U934A divides the 800 kHz by eight to get 100 kHz, which is the display rate frequency.

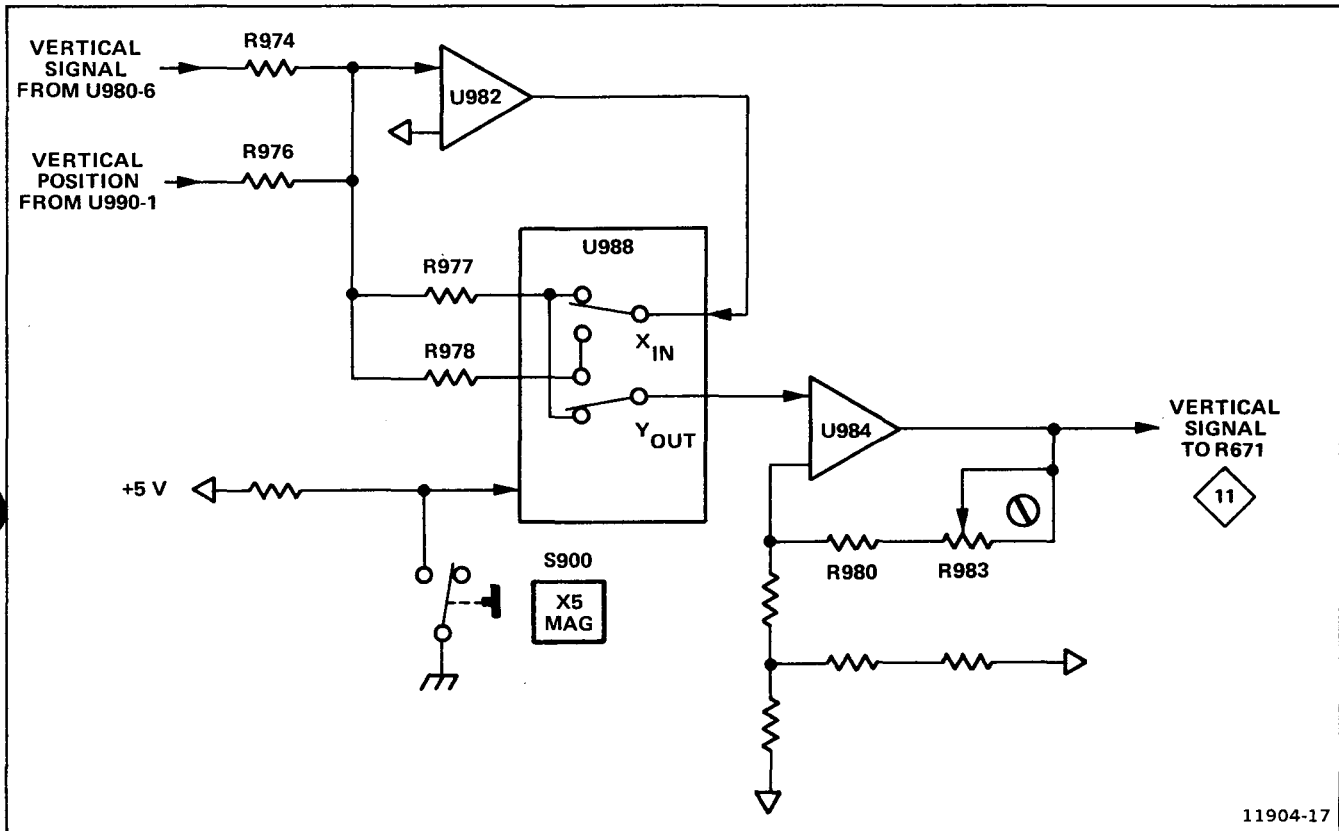

Figure 14. Simplified VERTICAL X5 MAG circuit.

U932B, U936B, U936A, and the A section of U932A make up the rest of the divide chain. U968A, U960, and U962A select a frequency that is determined by the setting of the 465 TIME/DIV switch (Table 4).

TABLE 4

TIME/DIV Switch Setting	Output of U962A
1 ms	50 kHz
2	25
5	10
10	5
20	2.5
50	1
0.1 s	500 Hz
0.2	250
0.5	100

TIME/DIV X10 13

U963 and U962B work in conjunction with the Mod UC TIME/DIV X10 switch S904 to slow the recording rate by a factor of ten. U963 is a decade counter. The DT line from S904 controls U962B. A HI lets the output of U963 pass through U962B, and a LO lets the output of U962A pass through U962B. Since the output frequency from U963 is ten times lower than the output frequency of U962A, the recording rate will be ten times slower when the DT line is HI.

Timing and Synchronization 13

U956A and U956B with U958A and U958B form a synchronizing circuit. When the B input (record rate) of U956B goes HI, the \bar{Q} output goes LO for about 5 μ s. This LO enables the data from the adc onto the data bus and puts the memory into the record mode. When the \bar{Q} output goes HI again, it clocks a HI onto the output of U958B. The next positive transition of the signal on pin 3 of U958A clocks the HI onto the output of U958A. This HI triggers a one-shot multivibrator, U956A. The output of U956A is the CONVERT COMMAND and the one-shot pulse width is wide enough so it will be HI during the next rise of the 800 kHz clock at pin 19 of U940.

The leading edge of the HI on the convert command input causes U940 to assert a HI on its STATUS output. The status signal enables U966B to permit the 800 kHz adc clock to start clocking the adc. At the same time, the status signal clocks the memory, ends the track period of the track-hold amplifier, and causes U920B to send an alt sync pulse to the Vertical Channel Switch of the 465 if the CHOP mode is selected. See Figure 15 for timing details.

Record or Display Control 13

The SINGL SWP button S1100 controls the start of the recording process. If the STORED DISPLAY IN button S338B is fully in, Q908 asserts a LO on pin 12 of U922. Pushing the SINGL SWP button will activate U924B. U924B is connected as an RS flip-flop and generates a pulse, free of any switch noise, that clocks U926A. The \bar{Q} output of U926A holds a reset on U970B, which arms the recording process and shuts off the display process. The Q output of U926A holds a reset on the memory counter (U934B, U938A, and U938B). The Mod UC is set to start the recording of a waveform and, when the SINGL SWP is triggered, an alt sync pulse coming from the 465 will reset U926A. Resetting U926A will remove the reset from U970B, remove the reset from the memory counter, and

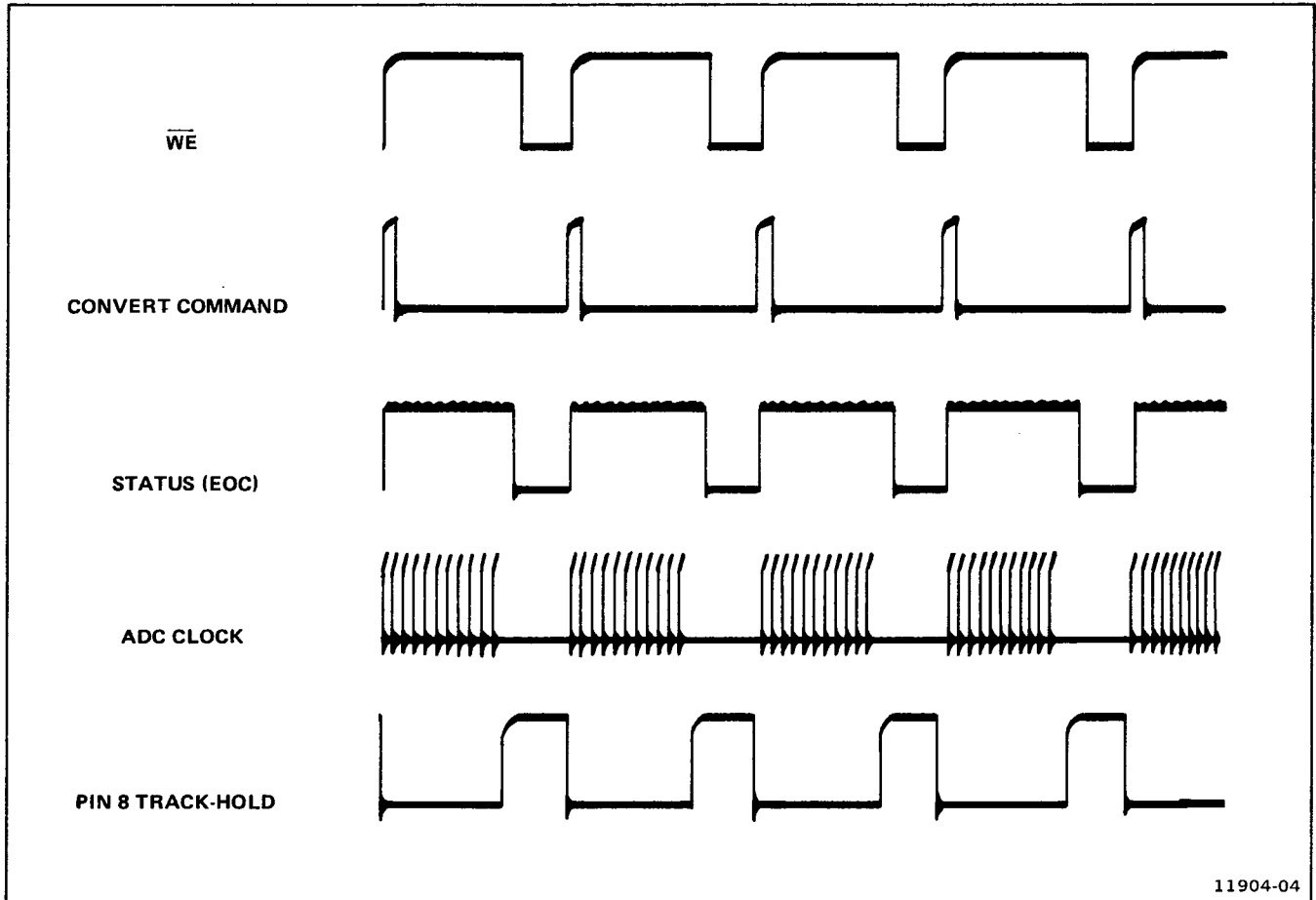

11904-04

Figure 15. ADC timing diagram.

clock U926B to cause it to change state. The memory counter starts counting the number of conversions being made by the adc. When 512 conversions have been made, U938A clocks U970 to produce a HI at its Q output. This ends the recording process and starts the display process again.

Overlay Control 13

U926B controls the OVERLAY FUNCTION during recording. A HI from U976C enables U976D and allows the output of U926B to control the most significant bit of memory address A9. Because U926B changes state once for each recording cycle, it will direct data into alternate halves of memory. During a TIME or VOLTS display U976C is disabled and its output will be HI. This HI is inverted by U964E and a LO is applied to U976B pin 4, preventing the Q_B output of U938A from controlling the most significant bit of memory address. The data that was last recorded will be displayed. When the OVERLAY FUNCTION is selected, U976C is activated and its output will go LO. The LO is inverted by U964E and a HI on pin 4 of U976B permits the Q_B output of U938A to alternately select each half of the memory for display.

Horizontal Ramp 13 14 15

The memory counter (U934B, U938B, and U938A) also drives the horizontal dac U946. The memory address count is proportional to the horizontal position of the sweep on the 465 crt. As the memory counter is incremented, the current output of U946 increases. U977B converts the output of U946 to a voltage. U996 generates a 2.5-volt reference that causes an offset for U997B. This offset causes the output of U977B to be a ramp, two volts in amplitude, centered about ground. U997A inverts the ramp and drives the horizontal output U981C. When the display is not enabled, a LO on the DE line turns on Q922, which shunts the ramp current from U981C to the +5-volt power supply. When the display is enabled, Q910 injects an offset current into the horizontal output. The offset current may be adjusted with R940 to set the start of the stored display sweep to the extreme left graticule line.

DOT 1 and DOT 2 Generation 14

The horizontal ramp is also fed to a comparator U998. When the TIME FUNCTION is selected, the voltages from the DOT 1 and DOT 2 controls, R990 and R992, are multiplexed by U994 and passed through U992 to pin 3 of U998. For each dot in the stored display, one of the time proportional voltages (DOT 1 and DOT 2) is compared to the ramp. When the ramp crosses the reference voltage on pin 3, U998 switches. The output of U998 resets U970A to trigger a one-shot multivibrator U972A. The Q output of U972A turns on U981E which puts a LO on the Z-AXIS SIG line. A LO on the Z-AXIS SIG line will cause the 465 Z-axis amplifier to intensify the electron beam in the crt to produce a bright dot on the stored display trace. Since DOT 1 and DOT 2 voltages are multiplexed together, two bright dots will appear on the crt. The time between the

dots is proportional to the difference between the voltages from the DOT 1 and DOT 2 controls. Q920 strobes the comparator to turn it on for each display dot.

Z-Axis Signal 14

The dots that make up the displayed waveform are produced by one-shot U972B and U981A. When the display is enabled (DE from U922-10), the falling edge of the clock pulse from U966D fires U972B. The output of U972B turns on U981A for the duration of the one-shot pulse width. The Z-AXIS SIG line receives the output of U981A and sends it to the Z-axis amplifier in the 465 to turn on the trace. While a waveform is being stored, U972B is inhibited by a HI (from U970 pin 8) on the RECORD line.

CHOP Mode Vertical Switching 13

When you store a display with the CHOP mode selected on the 465, the Mod UC takes control of the 465 Vertical Channel Switch. On U920A, if both pins 1 and 2 are HI (being in CHOP mode and record), U920D is inhibited by a LO on pin 12. The alt sync signal that normally switches the channel switch at the end of each sweep in the ALT mode is replaced by the recording rate from the status output of the adc U940. U920B pin 4 has a HI applied which enables it so the recording rate passes through U920C to J960. At the same time, Q906 turns on and Q904 turns off. Normally, in the CHOP mode of operation, current is fed through Q904 to turn on the CHOP multivibrator, but with Q906 on, the ALT mode is enabled. The input is selected alternately from CH 1 or CH 2 at the recording rate.

LED Display 15 16 17

U918 is a 3½-digit dvm that contains the linear and digital circuitry to convert the voltage input to the digital output required to control the light-emitting diode (LED) display. With two external resistors and two external capacitors, U918 forms a dual-ramp analog-to-digital converter. The unknown input voltage is measured as a ratio of the input voltage to a reference voltage. The reference voltage is generated by U983 and is adjusted to the correct value by R946, R947, and variable resistor R943. The reference voltage is applied to U918 between the reference input pin 2 and the analog ground pin 1. It floats on the LINE 2 or DOT 2 voltage that is applied to the analog ground pin. The analog ground pin is used as a reference ground input for measuring the voltage difference between the LINE 1 and LINE 2 VOLTS cursors or DOT 1 and DOT 2 TIME dots.

SCALING. Because all of the switch ranges of the 465 oscilloscope are multiples of a 1-2-5 sequence and all the measurements have a 10-division dynamic range, the maximum difference between the two cursor controls may be scaled for each range. A "1" scale such as 1 ms or .1 V would have a full-scale value of 1000 with the appropriate scale factor and decimal point location. A "2" scale has a full-scale reading of 1999 and a "5" scale has a full-scale

reading of 500 (again with the appropriate decimal point location and scale factor). These correspond to the 1 volt, 2 volt, and 0.5 volt inputs to the dvm U918.

The divider string comprised of R951, R950, and R949, working with multiplexer U928, does the scaling. The 1-2-5 range information is fed to the A and B inputs of U928 where it is used to select the correct scale factor for the unknown input voltage (2 volt, 1 volt, or 0.5 volt full scale). The scaled unknown voltage is measured by U918 and displayed on the LED display. U916 is the LED segment driver and U914 does the line selection.

UNCAL, DECIMAL POINT, AND SCALE FACTOR LIGHTS. U912 and U910 are four-bit digital comparators. They look at the TIME/DIV switch lines SS20 through SS26 and the NAND'ed combinations of SS25 and SS26. They compare this information, on their "A" side, with the hard-wired information on the "B" side. When the value of A is less than the value of B, the $A < B$ output goes HI to turn on the UNCAL light via U908B. The UNCAL light will turn on if the 465 TIME/DIV switch is set faster than 1 ms. If the 465 TIME/DIV switch is set to the X-Y position, all three inputs of U908C are LO, causing a HI at the output of U908C. This turns on the UNCAL light. Q913 turns off the UNCAL light whenever the STORED DISPLAY IN button is not fully in.

If the TIME/DIV switch is set faster than 1 ms or if it is set to the X-Y position, U908A will activate and prevent the recording of new switch-setting information in U730B, U900, and U924A. U900 records the position of the 465 TIME/DIV switch and the selected VOLTS/DIV setting. U703B records the presence of a 10X-coded probe on the selected vertical channel. U924A records the position of the Mod UC TIME/DIV X10 button.

U904 (a PROM) decodes the switch-setting information and selects the appropriate decimal point and scale factor LED. A HI on the O_2 , O_3 , or O_4 output of U904 is gated with the digit strobe from the dvm U918 to turn on the selected decimal point LED. A HI on O_1 , when the STORED DISPLAY IN button is fully in, and either TIME or VOLTS FUNCTION selected, selects the s/V scale LED; a LO selects the ms/mV scale LED.

U902 is a multiplexer that is switched by the TIME and VOLTS FUNCTION buttons. When the TIME FUNCTION is selected, the 465 TIME/DIV switch-setting information is passed to U904 to be decoded. When the VOLTS FUNCTION is selected, the 465 VOLTS/DIV switch-setting information is passed to U904 to be decoded. The 1-2-5 range information is passed to the scaling multiplexer with either TIME or VOLTS selected.

U705 is a digital comparator. When both inputs of all input pairs match (either both HI or both LO), pin 9 goes HI. U703A is connected as an inverter. If both CH 1 and CH 2 are selected by any of the dual channel modes (ALT, ADD, or CHOP) and both channels are set to the same sensitivity, pin 12 of U701A will be HI. If the two channels

are not set the same, U701A pin 12 will be LO and an UNCAL condition will be indicated.

U700B and U700D look at the selected channels and their respective VOLTS/DIV VAR controls. If either control is out of detent, a LO is applied to U701B and an UNCAL condition will be indicated.

U703B, U702, and U701C look at the channel that is selected and determine whether a 10X-coded probe is in use. If so, U703B stores that information for use in setting the LED display decimal point and scale factor.

U700C, U700A, and U704 form another multiplexer. If CH 1 is selected, U704 puts the CH 1 VOLTS/DIV switch-setting information on the bus to the main board. If CH 2 is selected, U704 puts the CH 2 VOLTS/DIV switch-setting information on the bus to the main board.

Power Supply

The Mod UC power supply is a floating supply that uses the accessory windings of the oscilloscope power transformer to provide the regulated voltages: +15 volts, +5 volts, and -15 volts.

The +15-volt supply is regulated by integrated circuit regulator U2614, which contains a reference voltage, output drivers, buffers, and associated components.

The +5-volt supply is regulated by integrated circuit regulator U2624, which also contains a reference voltage, output drivers, buffers, and associated components.

The -15-volts supply reference voltage is the +15-volt supply across R2635. Feedback from the junction of R2635 and R2634 is applied to the comparator composed of Q2638 and Q2634. Transistor Q2626 is the series regulator. Q2632 provides current limiting.

Ground to P940-2 is the digital ground and ground to P940-1 is the analog ground.

The -5-volt supply (located on the Mod UC main board) develops the -5 volts from the -15-volt supply. Pass transistor Q914 is biased at -5.6 volts, thus setting the output at about -5 volts.

ADJUSTMENT PROCEDURE

Test Equipment Required

Equipment needed to perform all the Adjustment Procedure is listed at the beginning of the procedure. Refer to Table 6-2 of the 465 Oscilloscope Instruction Manual for the required test equipment specifications.

465 Oscilloscope Calibration

The 465 oscilloscope must be operating within its specifications before the Adjustment Procedure may be carried out on the 465 DIGITAL STORAGE Mod UC. To calibrate the 465 oscilloscope, pull the STORED DISPLAY IN button to the center position and use the Calibration Procedure in Section 6 of the 465 manual. The 465 DIGITAL STORAGE Mod UC does not have a Trigger View, therefore omit steps 22 and 23 of the TRIGGERS subsection of the 465 Calibration Procedure when calibrating the oscilloscope. If it is determined that the 465 oscilloscope is operating normally, proceed with the DIGITAL STORAGE Mod UC adjustments.

INDEX TO ADJUSTMENT PROCEDURE

	Page
1. Check Power Supplies	22
2. Adjust +1.03 V Reference (R702)	22
3. Adjust -1.03 V Reference (R993)	22
4. Adjust 1.996 V Reference (R943)	22
5. Adjust Vertical Input Gain (R966)	22
6. Adjust Vertical Input Offset (R970)	23
7. Adjust Stored Display Centering (Trigger View Centering Control R675)	23
8. Adjust Vertical Master Gain (R983)	23
9. Adjust Vertical Signal Gain (R999)	23
10. Check VERTICAL DISPLAY X5 MAG	24
11. Adjust Horizontal Master Gain (R731)	24
12. Adjust Horizontal Signal Gain (R714)	24
13. Adjust Horizontal Registration (R940)	24
14. Check UNCAL Light	24
15. Check Readout Decimal Point	25

Preliminary Control Settings

Set the controls on the 465 DIGITAL STORAGE Mod UC as follows:

Vertical

VOLTS/DIV (both)	1 V
VOLTS/DIV VAR (both)	Calibrated detent
Vertical POSITION	Midrange
AC-GND-DC	DC
VERT MODE	CH 2
INVERT	Button out

Display

INTEN	As required for normal display
FOCUS	Midrange
SCALE ILLUM	Midrange

Trigger

SLOPE	+
LEVEL	0
SOURCE	CH 2
COUPLING	AC
TRIG MODE	AUTO
A TRIG HOLDOFF	NORM

Horizontal

HORIZ DISPLAY	A
TIME/DIV (A and B)	Locked together at 1 ms
A TIME/DIV VAR	Calibrated detent
X10 MAG	Off (button out)
Horizontal POSITION	Midrange

DIGITAL STORAGE

VERTICAL DISPLAY POSITION	Midrange
VERTICAL DISPLAY X5 MAG	Button out
TIME/DIV X10 FUNCTION	Button out
STORED DISPLAY IN	Determined by type of measurement to be made.
	Normal (button in center position)

Use the procedure in the Operating Instructions to obtain a Normal Sweep display. No signal is required.

PROCEDURE

Refer to **ADJUSTMENT AND TEST POINT LOCATIONS** foldout for the location of test points and adjustments in the following procedure.

Equipment Required

- | | |
|-------------------------|------------------------------|
| 1. Digital Voltmeter | 4. Time-Mark Generator |
| 2. Test Oscilloscope | 5. 50 Ω coaxial cable |
| 3. Amplitude Calibrator | 6. 50 Ω termination |

1. Check Power Supplies

- If the Mod UC cover has not previously been removed for complete calibration of the 465 oscilloscope, remove the cover from the Mod UC. Refer to the Maintenance information in this insert for the Cabinet removal procedure. If the Mod UC cover is removed in this step, return the oscilloscope to normal operation and proceed with the adjustment of the Mod UC.
- Connect the common lead of the digital voltmeter (dvm) to a convenient chassis ground. The grounded outside shell of the plugs on the circuit board is chassis ground. The Mod UC ground is common with the 465 ground.
- Connect the HI dvm lead as indicated in Table 5 to measure the supply voltages. Table 5 lists the test points, voltages, and acceptable range for each.

TABLE 5

Voltage	Access Point	Acceptable Range
+15 V	P940 pin 4	+14.25 to +15.75
+5 V	P040 pin 5	+4.75 to +25
-15 V	P940 pin 3	-14.25 to -15.75
-5 V	U918 pin 12	-4.5 to -5.5

- Disconnect the dvm HI lead from the Mod UC.

2. Adjust +1.03 V Reference (R702)

- Push the STORED DISPLAY IN button fully in.
- Connect the dvm HI test lead to pin 1 of the LINE 2 potentiometer. The common lead stays on chassis ground.
- Adjust R702 for a reading of +1.03 V \pm 0.010 V (+1.02 to +1.04).

3. Adjust -1.03 V Reference (R993)

- Connect the HI test lead of the dvm to pin 3 of the LINE 2 potentiometer. The common lead stays on chassis ground.
- Adjust R993 for a reading of -1.03 V \pm 0.010 V (-1.02 to -1.04).
- Disconnect HI and common dvm leads from the Mod UC.

4. Adjust 1.996 V Reference (R943)

- Connect the dvm HI and common leads to each end of R947, located next to U918 on the main circuit board of the 465 Mod UC.
- Adjust R943 for a reading of 1.996 V \pm 0.002 V (1.996 to 1.998).
- Disconnect the dvm leads from the Mod UC.

5. Adjust Vertical Input Gain (R966)

- Pull the STORED DISPLAY IN button out to the center position.
- Connect a probe ground lead from the test oscilloscope to the Mod UC chassis ground. Connect the probe tip to the end of R964 that is next to pin 3 of U977 on the Mod UC main board.
- Connect a five-volt signal from the Amplitude Calibrator to the CH 2 input of the 465 using a 50 Ω coaxial cable. Do not use a termination.
- Use the CH 2 Vertical POSITION control to center the trace and check for a five-division vertical display on the 465.

- e. Set the test oscilloscope Volts/Div switch to 1 V.
- f. Push the STORED DISPLAY IN button fully in.
- g. Adjust R966 for a five-division vertical display on the the test oscilloscope.

6. Adjust Vertical Input Offset (R970)

- a. Set the Ac-Gnd-Dc switch of the test oscilloscope to Gnd. Set the Volts/Div switch to 50 mV and position the trace vertically to the center graticule line.
- b. Set the Ac-Gnd-Dc switch of the test oscilloscope to Dc.
- c. Set the 465 CH 2 AC-GND-DC switch to GND.
- d. Pull the STORED DISPLAY IN button to the center (normal bandwidth) position.
- e. Adjust the 465 CH 2 Vertical POSITION control so that the trace on the 465 is on the center graticule line.
- f. Push the STORED DISPLAY IN button fully in.
- g. Adjust R970 for a zero-volts display on the test oscilloscope.
- h. Disconnect the test oscilloscope probe and ground lead from the 465 Mod UC.

7. Adjust Stored Display Centering (Trigger View Centering Control R675)

- a. This adjustment requires removal of the oscilloscope cabinet. If the cabinet has not previously been removed for calibration of the 465, refer to the Maintenance information in this insert for the Cabinet removal procedure. Refer to the 465 Service Manual, Adjustment Locations 4 pullout, for the location of R675. If the cabinet is removed in this step, return the oscilloscope to normal operation and proceed with the calibration of the Mod UC.
- b. Select the OVERLAY FUNCTION on the DIGITAL STORAGE front panel.
- c. Pull the STORED DISPLAY IN button to the center (normal bandwidth) position.
- d. Use the CH 2 Vertical POSITION control to align the 465 trace with the center horizontal graticule line.
- e. Set the Trigger SOURCE to LINE.
- f. Push the STORED DISPLAY IN button fully in.

- g. Press the SINGL SWP button twice.
- h. Use the VERTICAL DISPLAY POSITION control to overlay the two traces.
- i. Adjust R675 to align the stored display trace with the center horizontal graticule line.

8. Adjust Vertical Master Gain (R983)

- a. Select the VOLTS FUNCTION on the DIGITAL STORAGE front panel.
- b. Set the LINE 1 and LINE 2 controls for a DIGITAL STORAGE display readout of 6.00 V.

NOTE

There should be three traces visible at this time. The LINE 1 and LINE 2 voltage cursors and the stored display trace. The LINE 1 or LINE 2 controls will not cause any vertical movement of the stored display trace.

- c. Adjust R983 for a six-division vertical separation between the cursor lines. Use the VERTICAL DISPLAY POSITION control to align the display with the horizontal graticule lines.

9. Adjust Vertical Signal Gain (R999)

- a. If the Amplitude Calibrator was disconnected from the 465 CH 2 input during the procedure of step 7, re-connect the Amplitude Calibrator to the 465 CH 2 input as in step 5.
- b. Select the TIME FUNCTION on the DIGITAL STORAGE front panel.
- c. Set the Trigger SOURCE to CH 2.
- d. Set the CH 2 AC-GND-DC switch to DC.
- e. Pull the STORED DISPLAY IN button to its center position.
- f. Set TRIG MODE to AUTO.
- g. Use the 465 CH 2 Vertical POSITION control to center the displayed waveform.
- h. Press the STORED DISPLAY IN button fully in.
- i. Press the SINGL SWP button and use the VERTICAL DISPLAY POSITION control to center the displayed waveform.
- j. Adjust R999 for a five-division vertical display.

10. Check the VERTICAL DISPLAY X5 MAG

- a. Set the Amplitude Calibrator to 1 V.
- b. Press the SINGL SWP button and use the VERTICAL DISPLAY POSITION control to center the displayed waveform.
- c. Check for a one-division vertical display.
- d. Press the VERTICAL DISPLAY X5 MAG button.
- e. Check for a five-division vertical display $\pm 3\%$. Use the VERTICAL DISPLAY POSITION control to align the display with the horizontal graticule lines.
- f. Set the X5 MAG button back to normal.
- g. Disconnect the Amplitude Calibrator from the 465 CH 2 input.

11. Adjust Horizontal Master Gain (R731)

- a. Connect a 50 Ω coaxial cable from the Time-Mark Generator to a 50 Ω termination attached to the CH 2 input of the 465.
- b. Set the Time-Mark Generator to 1 ms.
- c. Pull the STORED DISPLAY IN button to the center (normal bandwidth) position.
- d. Set the TRIG MODE to AUTO. (Adjust TRIGGER LEVEL for a stable trace if necessary.)
- e. Use the Horizontal POSITION control to align the 1 ms markers with the vertical graticule lines.
- f. Push the STORED DISPLAY IN button fully in.
- g. Press the SINGL SWP button. (This stores the time marks. Because of their narrow pulse width, the time marks may not have been sampled at the maximum amplitude and may not be the same amplitude.)
- h. Use the 465 INTEN control to lower the intensity of the trace so only the intensified dots are visible.
- i. Set the DOT 1 and DOT 2 controls for a LED read-out of 8.00 ms.
- j. Adjust R731 so that the dots are eight horizontal graticule divisions apart. Use the Horizontal POSITION control to align the dots with the vertical graticule lines. If only one dot is visible, adjust R714 to make both dots appear on the trace.

12. Adjust Horizontal Signal Gain (R714)

- a. Use the 465 INTEN control to raise the intensity of the trace so the time marks are visible.
- b. Adjust R714 for one marker per division on the graticule. Use the Horizontal POSITION control to align the time marks with the vertical graticule lines.

13. Adjust Horizontal Registration (R940)

- a. Pull the STORED DISPLAY IN button to the center position.
- b. Set the TRIG MODE to AUTO.
- c. Use the Horizontal POSITION control to align the start of the trace with the extreme left vertical graticule line.
- d. Press the STORED DISPLAY IN button fully in.
- e. Adjust R940 to set the start of the stored display trace to the extreme left vertical graticule line.
- f. Disconnect the Time-Mark Generator from the 465 CH 2 input.

14. Check UNCAL Light

- a. Set the VERT MODE to ADD.
- b. Turn CH 2 VOLTS/DIV VAR out of detent.
- c. Verify that the UNCAL light comes on.
- d. Return CH 2 VOLTS/DIV VAR to detent and verify that UNCAL light turns off.
- e. Turn CH 1 VOLTS/DIV VAR out of detent.
- f. Verify that UNCAL light comes on.
- g. Return CH 1 VOLTS/DIV VAR to detent and verify that UNCAL light turns off.
- h. Set CH 1 VOLTS/DIV to 2 V.
- i. Verify that UNCAL light comes on.
- j. Set CH 2 VOLTS/DIV to 2 V.
- k. Verify that UNCAL light turns off.
- l. Attach a 10X-coded probe to the CH 1 input.

- m. Verify that UNCAL light comes on.
- n. Remove 10X-coded probe from CH 1 input and verify that UNCAL light turns off.
- o. Attach a 10X-coded probe to the CH 2 input.
- p. Verify that UNCAL light comes on.
- q. Remove 10X-coded probe from CH 2 input and verify that UNCAL light turns off.
- r. Set the 465 TIME/DIV switch to .5 ms or faster.
- s. Verify that UNCAL light comes on at .5 ms and remains on as the TIME/DIV switch is turned to all faster sweep speeds.
- t. Set the 465 TIME/DIV switch to X-Y.
- u. Verify that UNCAL light comes on.
- v. Return TIME/DIV switch to 1 ms, one step at a time, and verify that UNCAL light does not come on as the TIME/DIV switch is turned from .5 s to 1 ms. The light may flicker but should not remain on.

TABLE 6

TIME/DIV	Digital Display ±1%	s or ms light
1 ms	8.00	ms
5 ms	40.0	ms
20 ms	160.0	ms
50 ms	400	ms
.1 s	.800	s
TIME/DIV X10		
1 ms	80.0	ms
5 ms	400	ms
20 ms	1.600	s
50 ms	4.00	s
.1 s	8.00	s

NOTE

The display will take approximately 10 seconds to return on the last setting in Table 6.

- g. Check the decimal point and multiplier light for the VOLTS/DIV settings given in Table 7 by selecting each VOLTS/DIV setting and pressing the SINGL SWP button to store the switch-setting information in the Mod UC.

TABLE 7

VOLTS/DIV	Digital Display ±3%	V or mV light
1 V	6.00	V
.1 V	0.600	V
50 mV	300	mV
20 mV	120.0	mV
5 mV	30.0	mV

15. Check Readout Decimal Point

The displays given in Table 6 depend on the dots being set as described in step 5. If the dots have been moved, set them eight horizontal divisions apart.

- a. Set the VERT MODE to CH 2.
- b. Set the Trigger SOURCE to LINE.
- c. Check the decimal point and multiplier light for the TIME/DIV settings given in Table 6 by selecting each TIME/DIV setting and pressing the SINGL SWP button to store the switch-setting information in the Mod UC.
- d. Select the VOLTS FUNCTION on the DIGITAL STORAGE front panel.
- e. Set the LINE 1 and LINE 2 controls for a six-division vertical difference between the voltage measurement cursors.
- f. Set the TIME/DIV switch to 1 ms.

- h. Set the VERT MODE to CH 1.
- i. Repeat step 15, part g.
- j. Connect a 10X-coded probe to the CH 1 input connector. Do not connect the probe to an input signal source. The 10X-coded probe is used to activate the decimal-point-shift circuitry in the oscilloscope.
- k. Check the decimal point and multiplier light for the VOLTS/DIV setting given in Table 7 by selecting each VOLTS/DIV setting and pressing the SINGL SWP button to store the switch-setting information in the Mod UC.

This concludes the Adjustment Procedure. Reinstall the oscilloscope cabinet and Mod UC cover in the reverse order of the steps of the Cabinet removal procedure in this insert. Turn the instrument on after cabinet reinstallation and check for normal operation.

MAINTENANCE

MAINTENANCE PRECAUTIONS

To reduce the possibility of personal injury or instrument damage, observe the following precautions.

1. Disconnect instrument from power source before removing or installing components.
2. Use care not to interconnect instrument grounds which may be at different potentials (cross grounding).
3. Do not use excessive heat when soldering. This can damage circuit boards and semiconductors.

7. Do not slide the components over any surface.
8. Avoid handling components in areas that have a floor or work-surface covering capable of generating a static-charge.
9. Use a soldering iron that is connected to earth ground.
10. Use only special antistatic suction type or wick type desoldering tools.

Static-Sensitive Components



Static discharge can damage any semiconductor component in this instrument.

This instrument contains electrical components that are susceptible to damage from static discharge. See Table 8 for relative susceptibility of various classes of semiconductors. Static voltages of 1 kV to 30 kV are common in unprotected environments.

Observe the following precautions to avoid damage:

1. Minimize handling of static-sensitive components.
2. Transport and store static-sensitive components or assemblies in their original containers, on a metal rail, or on conductive foam. Label any package that contains static-sensitive assemblies or components.
3. Discharge the static voltage from your body by wearing a wrist strap while handling these components. Servicing static-sensitive assemblies or components should be performed only at a static-free work station by qualified service personnel.
4. Nothing capable of generating or holding a static charge should be allowed on the work station surface.
5. Keep the component leads shorted together whenever possible.
6. Pick up components by the body, never by the leads.

TABLE 8

Relative Susceptibility to Static Discharge Damage

Semiconductor Classes	Relative Susceptibility Levels ^a
MOS or CMOS microcircuits or discretes, or linear microcircuits with MOS inputs. (Most Sensitive)	1
ECL	2
Schottky signal diodes	3
Schottky TTL	4
High-frequency bipolar transistors	5
JFETs	6
Linear microcircuits	7
Low-power Schottky TTL	8
TTL (Least Sensitive)	9

^aVoltage equivalent for levels:

- | | | |
|------------------|------------------|--------------------------|
| 1 = 100 to 500 V | 4 = 500 V | 7 = 400 to 1000 V (est.) |
| 2 = 200 to 500 V | 5 = 400 to 600 V | 8 = 900 V |
| 3 = 250 V | 6 = 600 to 800 V | 9 = 1200 V |
- (Voltage discharge from a 100 pF capacitor through a resistance of 100 ohms.)

OBTAINING REPLACEMENT PARTS

Standard Parts

All electrical and mechanical part replacements for this instrument can be obtained through your local Tektronix Field Office or representative.

NOTE

Physical size and shape of a component may affect instrument performance. Always use direct replacement components, unless you know that a substitute will not degrade instrument performance.

Special Parts

In addition to the standard electronic components, some special components are used in this instrument. Some are manufactured or selected by Tektronix, Inc. to meet specific performance requirements. Others are manufactured for Tektronix, Inc. according to our specifications. Most of the mechanical parts used in this instrument have been manufactured by Tektronix, Inc. Order all special parts directly from your local Tektronix Field Office or representative.

Ordering Parts

When ordering replacement parts from Tektronix, Inc., include all of the following information to ensure receiving the proper parts.

1. Instrument type (include modification or option numbers).
2. Instrument serial number.
3. A description of the part (if electrical, include the circuit number).
4. Tektronix part number.

CABINET REMOVAL

WARNING

To prevent electrical shock, disconnect power before removing the cabinet.

DIGITAL STORAGE Mod UC Cover

Use the following procedure to remove the Mod UC cover.

1. Disconnect power cord.
2. Remove two screws from the Mod UC cover (see Figure 16).
3. Slide the Mod UC cover slightly to the rear of the instrument and lift up to remove.

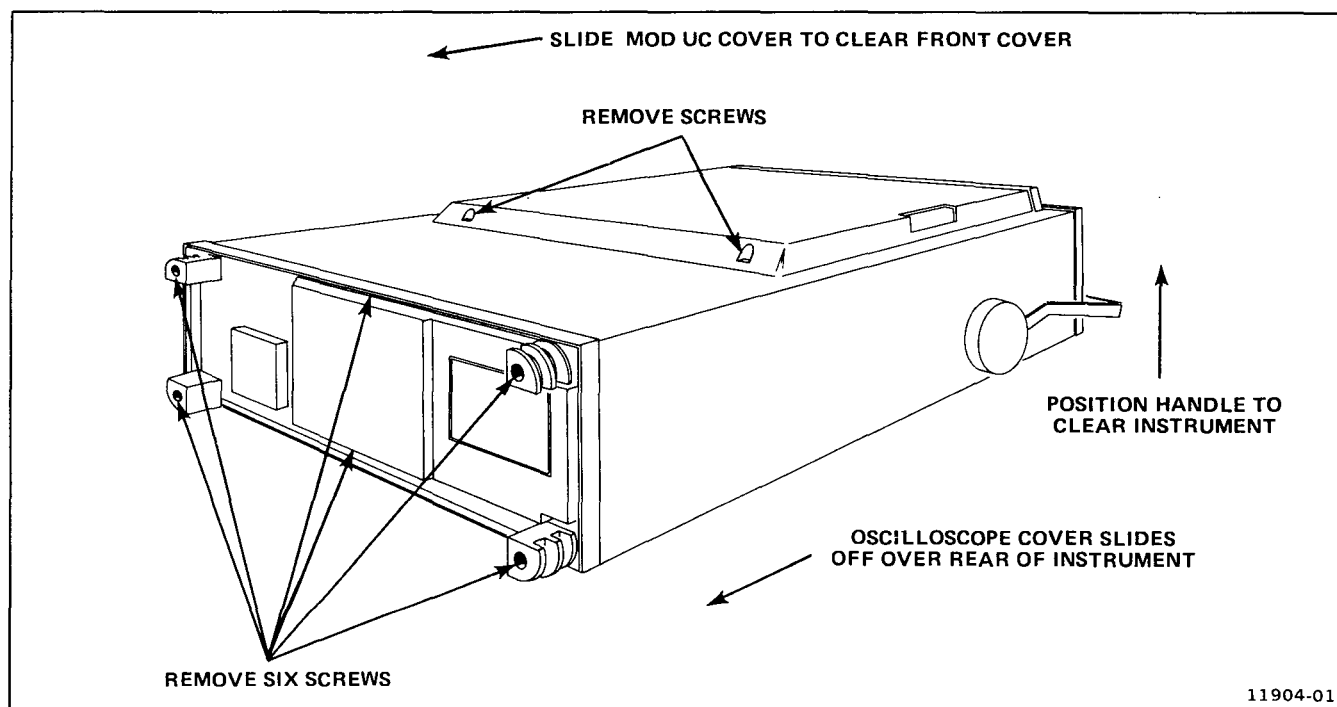

Figure 16. 465 Mod UC cover removal.

Oscilloscope Cabinet

Use the following procedure to remove the oscilloscope cabinet.

1. Disconnect the instrument power cord from the power source.
2. Install the front-panel cover and set the instrument face down on a flat surface.
3. Unwrap the power cord from the instrument feet.
4. Loosen the six screws, indicated in Figure 16, enough to release the rear ring. Remove the rear ring with feet and screws from the instrument as an intact assembly.
5. Remove the Mod UC cover if not previously removed.
6. Slide the cabinet up until it is separated from the instrument and power cord.

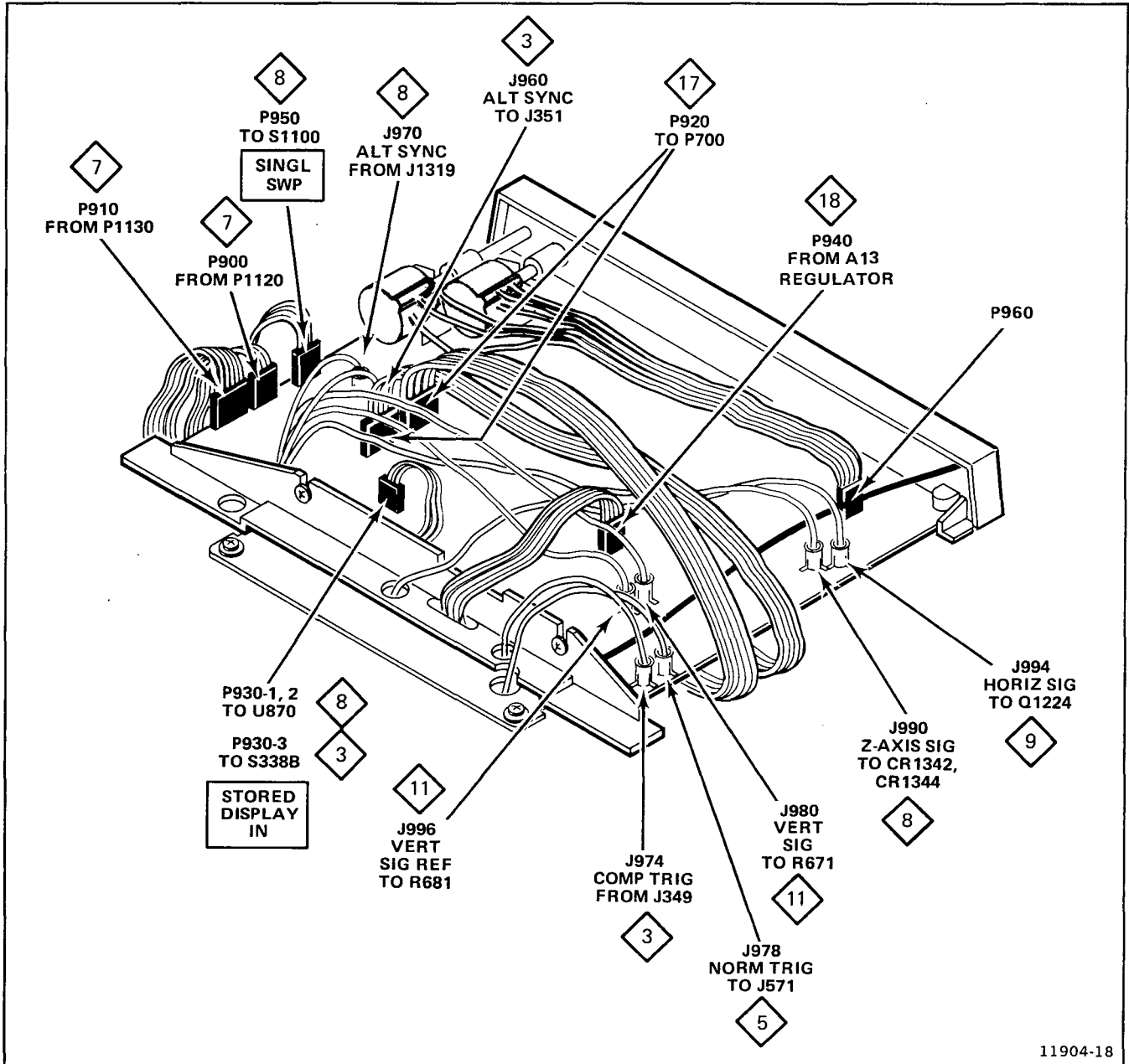

Figure 17. Location of plugs and connectors.

DISASSEMBLY PROCEDURES**Mod UC-Oscilloscope Separation**

1. Disconnect the instrument from the power source.
2. Remove the instrument covers (see Cabinet Removal).
3. After making a note of their location and color codes to aid reassembly, disconnect:

J960	J990	P920
J970	J994	P930
J974	J996	P940
J978	P900	P950
J980	P910	

Align the connector pins carefully when reassembling. Align the arrow on the square pin connectors with the arrow on the ECB.

4. Make a note of the route that each cable takes to aid reassembly. Figure 17 may aid you.
5. Remove two screws from the rear of the Mod UC ECB support bracket. (Refer to Figure 18.)
6. Slide the Mod UC slightly toward the rear of the oscilloscope to clear the front lip of the oscilloscope frame.

7. While guiding all the connectors and wires through the holes in the ECB and the ECB support to make sure they are clear, lift the Mod UC slowly away from the oscilloscope.

Front Panel Removal

Use the following procedure to remove the Mod UC front panel.

1. Disconnect the instrument from the power source.
2. Separate the Mod UC from the oscilloscope (see previous procedure).
3. Use a 1/16-inch allen head wrench to loosen and remove three control knobs from the Mod UC front panel.
4. Remove ground lead from post on ECB support at rear of main board.
5. Remove three screws from the bottom of the main board (near the front of the Mod UC ECB).
6. Carefully separate the front panel from the main board. When reinstalling the front panel, carefully align the pins on the readout board with the connector on the main board.

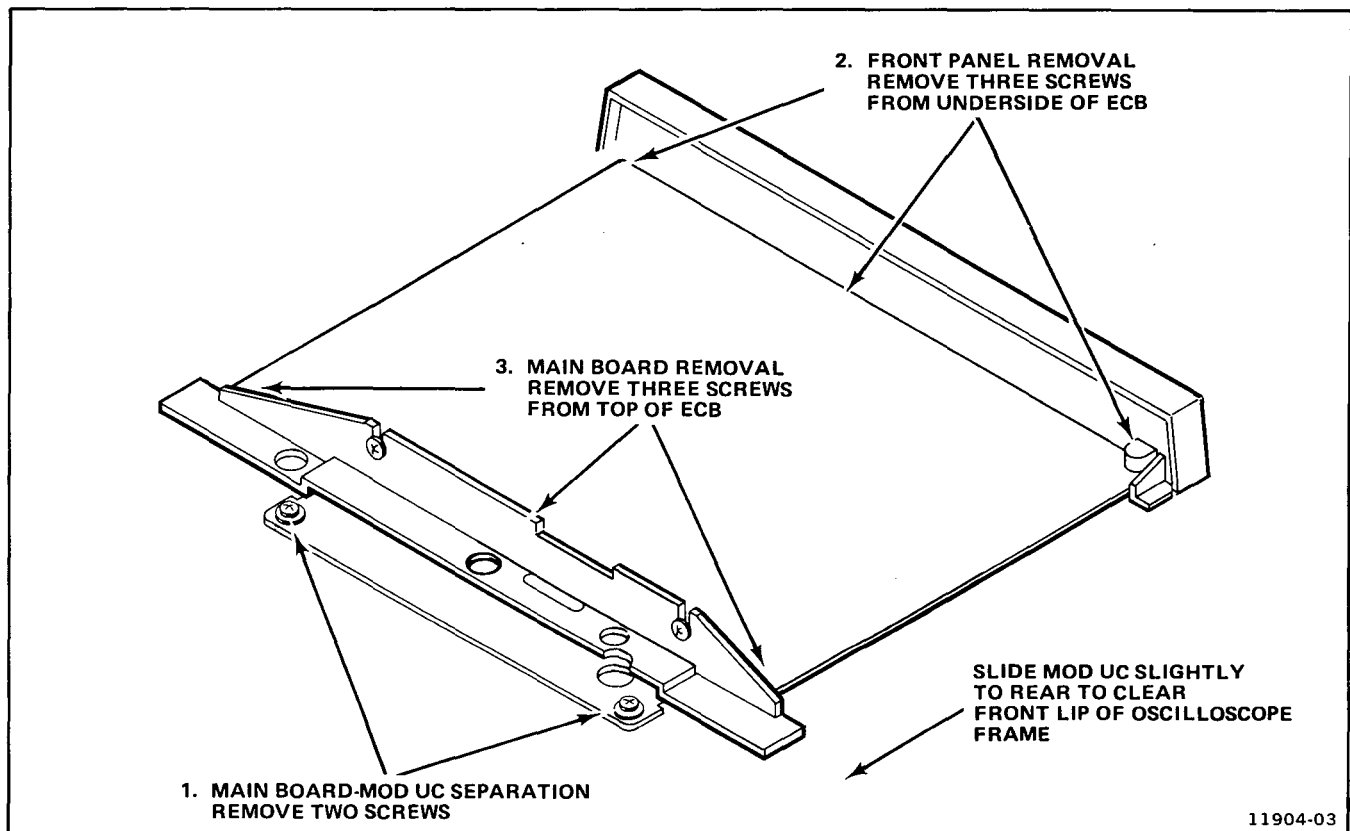

Figure 18. Mod UC and Oscilloscope separation.

11904-03

Readout Board Removal

Use the following procedure to remove the readout board.

1. Disconnect the instrument from the power source.
2. Remove the Mod UC front panel (see previous procedure).
3. Remove two screws from the readout board.
4. Pull the readout board away from the front panel.

Main Board Removal

Use the following procedure to remove the main board from the ECB support.

1. Disconnect the instrument from the power source.
2. Separate the Mod UC from the oscilloscope and remove the Mod UC front panel (see previous procedures).
3. Remove three screws from the rear of the main board ECB.
4. Lift the main board from the ECB support.

Mod UC Power Supply Removal

Use the following procedure to remove the Mod UC power supply assembly from the oscilloscope. Refer to Figure 19.

1. Disconnect the instrument from the power source.
2. Remove the instrument covers (see Cabinet Removal).
3. Unsolder five wires from the power transformer. Note the color codes as an aid in reassembly.
4. Remove one screw from near the power transformer.
5. Disconnect P940 from the Mod UC main board.
6. Remove two screws from the power supply chassis.
7. While guiding the five-wire ribbon cable through the chassis, lift the Mod UC power supply assembly away from the oscilloscope.

PREVENTIVE MAINTENANCE

The preventive maintenance information in the 465 Oscilloscope Service Manual also applies to the Mod UC and will not be repeated here.

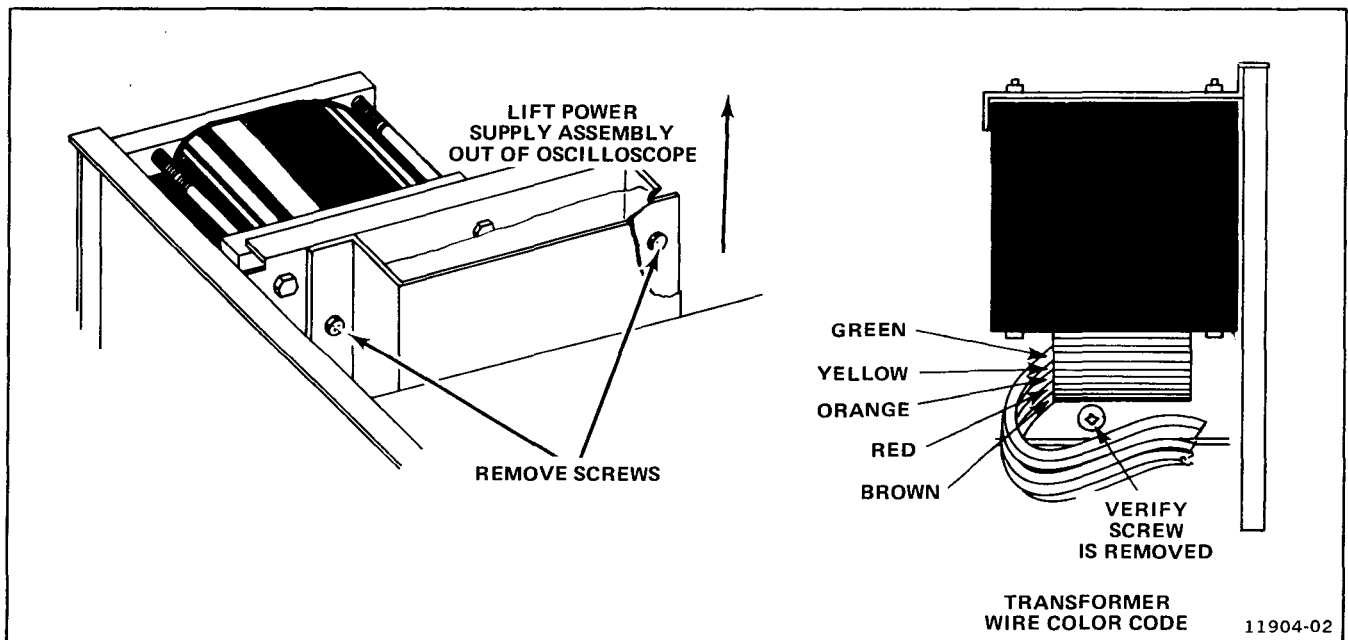

Figure 19. Mod UC power supply assembly removal.

TROUBLESHOOTING

RECOMMENDED TEST EQUIPMENT

The following test equipment is useful in troubleshooting the Mod UC.

1. Digital multimeter such as a Tektronix DM44, a Tektronix DM501, or a Tektronix DM502.
2. Test oscilloscope such as a Tektronix 465 portable oscilloscope or a Tektronix 464 portable storage oscilloscope.

NOTE

Before using any test equipment to make measurements on static-sensitive components or assemblies, be certain that any voltage or current supplied by the test equipment does not exceed the limits of the component to be tested.

TROUBLESHOOTING AIDS

Circuit Description

An understanding of circuit operation is necessary when troubleshooting. See the Theory of Operation for the circuit description. To locate the discussion of the circuit you suspect, see the Table of Contents at the front of this insert.

Diagrams

Schematic diagrams of the Mod UC circuitry are located in the foldout pages at the rear of this insert.

Voltages and Waveforms

Typical voltages are given on the diagrams containing linear transistors. Most of the circuitry in the Mod UC is digital and the active leads to the ICs will have either a HI, a LO, or a changing voltage level depending on the operation that is occurring. Waveforms are shown on page opposite the diagram. These are typical waveforms and may vary slightly from instrument to instrument. Each waveform is numbered. The source of the waveform is indicated on the diagram and on the Test Point and Adjustment locations illustration by this number.

Circuit Board Illustrations

The circuit board components locations illustrations show the physical location of each component on the circuit boards of the Mod UC.

TROUBLESHOOTING TABLE

Using the Troubleshooting Table

Column 1 of the table is a listing of actions to be taken to obtain an indication of operation of the Mod UC and directions to be followed when the indication is being observed. Column 2 is a list of malfunction indications that may appear during the troubleshooting procedure. Column 3 is a list of checks to be made if the malfunction indication listed in Column 2 occurs.

The steps that appear in Column 3, in general, start from the output of the particular signal path being checked and proceed toward the beginning of the signal path. In the instances that the order of the verification steps were reversed, it was for ease of testing. Follow the schematic diagrams as you are troubleshooting to help you decide the logical place to make a check that will reduce the time required to isolate the circuit causing the malfunction.

A useful point to make a quick check is at those steps that have a waveform indicator added. The waveform numbers are indicated in the schematic diagrams and the source of the waveform is indicated on the Test Point and Adjustment Locations Foldout at the rear of this insert.

In the instances where you are directed to remove an IC from its socket, or disconnect connectors or components, disconnect the line voltage before removing or disconnecting and again before replacing or re-connecting components.

The logic levels in the troubleshooting table are TTL logic levels. A HI is +2 to +5 volts and a LO is 0 to +0.7 volts. It is assumed that the supply voltages have been checked and are within the acceptable limits given in Table 5.

Set the 465 Mod UC controls as follows:

VERT MODE	CH 2
AC-GND-DC (CH 2)	GND
VOLTS/DIV	1 V
Trigger SOURCE	LINE
TRIG MODE	NORM
Trigger COUPLING	AC
TIME/DIV	1 ms
HORIZ DISPLAY	A
STORED DISPLAY IN	Center (Normal)
Mod UC	
FUNCTION	TIME
VERTICAL DISPLAY	
POSITION	Midrange
X5 MAG	Button out
TIME/DIV X10	Button out

Pull power on and obtain a normal trace. Use the CH 2 Vertical POSITION control to center the trace.

TABLE 9
Troubleshooting

Action	Malfunction Indication	Check
<p>1A. Push STORED DISPLAY IN fully in. Push SINGL SWP button.</p> <p>TRIG light should flash and stored baseline should appear on the crt. If so, proceed to step 3.</p>	<p>TRIG light does not flash when SINGL SWP is pushed.</p>	<p>Mod UC Record enable.</p> <hr/> <p>Verify that:</p> <ol style="list-style-type: none"> 1. Pin 2 of P930 steps momentarily LO when SINGL SWP is pushed. 2. Pin 12 of U968 is HI. 3. Pin 9 of U970 steps momentarily LO when SINGL SWP is pushed. 4. Pin 13 of U970 steps momentarily LO when SINGL SWP is pushed. 5. Pin 3 of U926 is HI while SINGL SWP is pushed, otherwise LO. 6. Pin 1 of U926 steps momentarily LO when SINGL SWP is pushed. 7. Pin 11 of U922 is LO.
<p>1B.</p>	<p>TRIG light flashes but stored baseline does not appear on the crt.</p>	<p>Proceed to step 2.</p>
<p>2A. Push BEAM FIND.</p>	<p>Dot appears</p>	<p>Horizontal Output circuits</p> <hr/> <p>Pull Peltola connector from J994. Connect a 100 ohm resistor from J994 to ground. Check for a 0.25 volt p-p sawtooth on J994.</p> <p>If no sawtooth is present, lift one end of CR981 and check J994 for a sawtooth.</p> <p>If sawtooth is present, check Horizontal Offset circuit.</p> <p>If sawtooth is not present with CR981 disconnected, re-connect CR981 and verify that:</p> <ol style="list-style-type: none"> 1. Junction of R719 and R720 is 4.4 volts or higher. 2. There is a 2 volt p-p sawtooth on pins 1 and 7 of U997. Waveform 11. 3. Remove U997 from its socket. There should be a 2.5 volt p-p sawtooth on pin 6 of U997's socket. 4. Replace U997 and re-connect J994.

TABLE 9 (cont)

Action	Malfunction Indication	Check
2A. (cont)		<p>Horizontal Digital circuits</p> <hr/> <p>Verify that:</p> <ol style="list-style-type: none"> 1. Digital pulses are present on pins 4 through 12 of U946. Pin 4 is waveform 7. 2. Pins 2 and 12 of U938 are LO. 3. Pin 12 of U934 is LO. 4. There is a 100 kHz square wave on pin 13 of U934. 5. Pin 13 of U966 is HI. 6. Pin 3 of U968 has a 100 kHz square wave. 7. Pin 2 of U968 is HI.
2B.	Centered baseline appears.	<p>Z-Axis Output circuits</p> <hr/> <p>Pull Peltola connector from J990. Connect a 1 kΩ resistor from J990 to ground.</p> <p>Check for a 100 kHz square wave switching between ground and -1.5 volts.</p> <p>If this signal is not present, reconnect J990 and verify that:</p> <ol style="list-style-type: none"> 1. DC voltages around U981 are approximately as given in schematic diagram 14. 2. 100 kHz pulses are present on pin 5 of U972. 3. Pins 3 and 11 of U972 are HI. 4. Pin 9 of U972 is LO. 5. Pin 10 of U972 has 100 kHz pulses present.
2C.	<p>Baseline appears with horizontal offset, or short trace appears with a bright dot at one end.</p> <p>Trace cannot be centered horizontally in stored mode only.</p>	<p>Verify that Horizontal POSITION control works normally in real time. (STORED DISPLAY IN set to center position.)</p> <p>Check Horizontal Output circuits and Horizontal Digital circuits (2A).</p>
2D.	Baseline appears with vertical offset.	Adjust VERTICAL DISPLAY POSITION control. If trace cannot be centered, proceed to step 3.

TABLE 9 (cont)

Action	Malfunction Indication	Check
3A. Center trace with VERTICAL DISPLAY POSITION control. If trace can be centered proceed to step 4.	Trace cannot be centered vertically.	Continue with actions listed in Column 1.
3B. Remove U944 from its socket. If trace can now be centered, proceed to Vertical Input circuits and ADC operation (3C).	Trace cannot be centered vertically with U994 removed from its socket.	<p>Vertical Output circuits.</p> <p>Leave U944 out of its socket. Pull Peltola connectors from J980 and J996. Verify that:</p> <ol style="list-style-type: none"> 1. J996 is approximately -0.6 volts. 2. J980 is approximately -0.6 volts and can be varied slightly by turning VERTICAL DISPLAY POSITION knob. 3. Pin 3 of U984 can be varied from -0.2 volts to +0.2 volts with VERTICAL DISPLAY POSITION knob. 4. Pins 3, 4, 11, and 13 of U988 have identical voltages. 5. Pins 9 and 10 of U988 are HI. 6. Pins 2, 3, and 6 of U980 are within 50 mV of ground. 7. Pins 10 and 11 of U922 are LO. 8. Pins 2 and 6 of U986 are within 20 mV of ground. <p>Replace U944 in its socket and reconnect J980 and J996.</p> <p>If the problem has been found and corrected, proceed to step 4.</p>
3C.	Trace can be centered vertically with VERTICAL DISPLAY POSITION control only when U944 is removed from its socket.	<p>Vertical Input circuits and ADC operation</p> <p>Put U944 back in its socket. Pull STORED DISPLAY IN to its center position. Set TRIG MODE to AUTO. Center trace with CH 2 POSITION control. Push STORED DISPLAY IN fully in and push SINGL SWP button.</p> <p>Verify that:</p> <ol style="list-style-type: none"> 1. Voltages on pin 6 of U978 and pin 5 of U977 are not more than ±1 V from ground. 2. A burst of 50 kHz pulses occur on pin 18 of U940 when SINGL SWP is pushed. Waveform 3.

TABLE 9 (cont)

Action	Malfunction Indication	Check
3C. (cont)		<p>3. A burst of pulses (approximately 800 kHz) occurs on pin 19 of U940 when SINGL SWP is pushed. Waveform 1.</p> <p>4. Data bus between U944 and U954, U952, and U942 is not open or shorted.</p> <p>5. Data bus between U942 and U940 is not open or shorted.</p> <hr/> <p>ADC operation</p> <hr/> <p>Connect a 10 volt p-p, 1 kHz signal to CH 2. Set Trigger SOURCE to LINE. Set CH 2 AC-GND-DC switch to AC. Set Trigger LEVEL so TRIG light flashes when SINGL SWP is pushed.</p> <p>Verify that:</p> <p>Each data bus output of U940 (pins 1 through 6 and pins 29 through 32) shows a burst of digital pulses when SINGL SWP is pushed. Output remains HI or LO at end of conversion. With Trigger SOURCE set to LINE, the final state of output lines should be random.</p> <p>Reset controls as follows:</p> <p>Trigger SOURCE to CH 2. AC-GND-DC switch to GND.</p>
4. If LED readout and range lights are on whenever a stored trace is displayed, proceed to step 5.	LED readout and range light not on whenever a stored trace is displayed.	<p>LED Logic circuits</p> <hr/> <p>1. +5 volts is present at pin 4 of P914, the readout board connector.</p> <p>2. Logic pulses are present on at least some of the following pins of U916: Pins 9, 10, 11, 12, 13, 14, or 15.</p> <p>3. Pin 4 of U916 is HI.</p> <p>4. Pin 9 of U914 is LO.</p> <p>5. Pins 2, 5, 7, and 15 have logic pulses present.</p>

TABLE 9 (cont)

Action	Malfunction Indication	Check
<p>5A. Connect a 5 volt p-p, 1 kHz signal to CH 2 input. Set Trigger SOURCE to CH 2. Set AC-GND-DC switch to DC.</p> <p>Push SINGL SWP button.</p> <p>A 1 kHz, 5 volt p-p signal should be displayed on the crt.</p>	<p>Stored signal does not appear on the crt.</p>	<p>Check Vertical Input circuits and ADC operation (3C).</p>
<p>5B. If the display is correct, proceed to step 6.</p>	<p>Display vertical scale factor is incorrect.</p>	<p>Vertical Output circuits</p> <p>Verify that:</p> <ol style="list-style-type: none"> 1. A 40 mV p-p signal is present at J980. 2. A 0.5 volt p-p signal is present at pin 6 of U984. 3. A 0.2-volt p-p signal is present at pins 3, 4, 11, and 13 of U988. 4. A 1-volt p-p signal is present at pins 2, 3, and 6 of U980. 5. A 1-volt p-p signal is present at pins 12 and 14 of U922, and pin 6 of U986. <p>Input Amplifier circuits</p> <p>Remove U986 from its socket. Check at pin 2 of U986's socket for a 2.2 volt p-p signal when SINGL SWP is pushed.</p> <p>Replace U986 in its socket and verify that:</p> <ol style="list-style-type: none"> 1. A 5 volt p-p signal is present at pin 3 of U977. 2. A burst of 5 volt p-p signal is present a pin 5 of U977 when SINGL SWP is pushed. 3. A 160 mV p-p signal is present at pin 3 of U978.
<p>5C.</p>	<p>Display horizontal scale factor is incorrect.</p>	<p>Clock and Divide Chain</p> <p>Check that TIME/DIV is set to 1 ms and Mod UC TIME/DIV X10 button is out.</p> <p>Verify that:</p> <ol style="list-style-type: none"> 1. There is a 100 kHz square wave present at pin 13 of U934.

TABLE 9 (cont)

Action	Malfunction Indication	Check
5C. (cont)		2. A burst of 50 kHz pulses occur momentarily on pin 18 of U940 whenever SINGL SWP is pushed and sweep is triggered. Waveform 3. 3. 50 kHz pulses are present at pin 8 of U962. 4. 800 kHz pulses are present at pin 7 of U932. Waveform 9.
6. Select TIME FUNCTION on the Mod UC. Adjust INTENSITY control to display two dots on the crt trace. If the timing dots are displayed, proceed to step 7.	Timing dots are not visible.	Dot Generation circuits Verify that: <ol style="list-style-type: none"> 1. There are 2.4 volt p-p 4 μs wide pulses present on pin 12 of U981. These pulses should move with respect to each other as one of the DOT controls is adjusted. 2. A pulse train of alternating pulse widths is present on pin 2 of U972. Waveform 14. 3. Pin 3 of U972 is HI. 4. A pulse train of alternating pulse widths is present on pin 1 of U970. 5. A 200 Hz square wave is present at pin 3 of U970. 6. Pin 4 of U970 is HI. 7. A 2 volt p-p sawtooth (centered around zero) is present on pin 2 of U998. Waveform 12. 8. A 50 Hz square wave is present at pin 3 of U998. (Amplitude depends on setting of DOT controls. With the two DOT controls set to opposite extremes, amplitude should be 2 volts p-p.) 9. A 100 kHz strobe is present at pin 6 of U998. Waveform 13. 10. Pins 10 and 11 of U992 are LO. 11. Signal on pin 2 of U992 should be identical to signal on pin 15 of U992. 12. Pin 13 of U992 has a signal which is a composite of signals on pins 2 and 12 of U992.

TABLE 9 (cont)

Action	Malfunction Indication	Check
6C. (cont)		13. Pin 9 of U994 has a 100 Hz square wave present. 14. Pin 10 of U994 has a 50 kHz square wave present. 15. The -1.03 volt and +1.03 volt references are correct.
7. Check that TIME/DIV is set to 1 ms. Set timing dots eight-horizontal divisions apart. If LED readout reads approximately 8 ms, proceed to step 8.	LED readout does not agree with dots.	Voltage Reference and Scaling circuit Verify that: 1. Voltage between pins 1 and 2 of U918 is 1.996 ±0.002 volts. 2. Voltage between pins 1 and 3 of U918 is close to 0.800 volts. 3. Pin 9 of U928 is LO and pin 10 is HI. 4. Voltage between pin 15 of U928 and pin 1 of U918 is close to 1.6 volts.
8. Select VOLTS FUNCTION on Mod UC. A stored signal and two horizontal voltage cursors should appear on the crt. The two cursors can be controlled by the LINE 1 and LINE 2 controls. If the display is correct, proceed to step 9.	Voltage cursors not present on crt with stored signal.	Vertical Signal Multiplexing and Reference Voltages Verify that: 1. Pins 10 and 11 of U992 are HI. 2. A 50 Hz square wave is present at pin 2 of U992. The amplitude of the square wave is adjustable with the LINE controls. 3. Identical signals are present on pins 13 and 14 of U992. 4. The signal on pin 13 of U992 is a composite of the signals present on pins 2, 4, and 12 of U992. Waveform 10. 5. Pin 9 of U994 has a 100 Hz square wave present and pin 10 has a 50 Hz square wave present.

TABLE 9 (cont)

Action	Malfunction Indication	Check
8. (cont)		<p>6. Voltage on pin 5 of U994 varies between +1 volt and -1 volt as the LINE 1 control is turned from one extreme to the other.</p> <p>7. Voltage on pin 1 of U994 varies between +1 volt and -1 volt as the LINE 2 control is turned from one extreme to the other.</p>
<p>9. Select OVERLAY FUNCTION on the Mod UC.</p> <p>If two traces are displayed on the crt, proceed to step 10.</p>	Two stored traces do not appear on the crt.	<p>OVERLAY logic</p> <p>Verify that:</p> <ol style="list-style-type: none"> 1. A 100 Hz square wave is present on pin 1 of U954, U952, U950, and U948. Waveform 6. 2. A 100 Hz square wave is present on pin 5 and 6 of U976. 3. The voltage on pin 13 of U976 alternates between HI and LO with each push of SINGL SWP button. 4. Pin 12 of U976 is LO. <p>Continue with VERTICAL DISPLAY POSITION circuit if malfunction remains.</p>
<p>10. Use the VERTICAL DISPLAY POSITION control to overlay the two stored traces.</p> <p>The most recently stored trace should be capable of being positioned vertically with the VERTICAL DISPLAY POSITION control.</p>	Most recently stored display cannot be vertically positioned.	<p>VERTICAL DISPLAY POSITION circuit</p> <ol style="list-style-type: none"> 1. A 100 Hz square wave is present on pin 1 of U990 and pin 14 of U974. 2. A 100 Hz square wave is present on pin 10 of U974. 3. Pin 11 of U974 is HI. 4. Voltage on pin 15 of U974 can be adjusted from -1 volt to +1 volt with the VERTICAL DISPLAY POSITION control.

REPLACEABLE ELECTRICAL PARTS

Changes to 465 Electrical Parts List

Ckt No.	Tektronix Part No.	Name and Description	Ckt No.	Tektronix Part No.	Name and Description
A3	037-6305-00	CKT BOARD ASSY:VERT PREAMP	A11	037-6304-00	CKT BOARD ASSY:MAIN BOARD
A8R671	315-0201-00	RES:200 OHM,5%,0.25W	C900	285-0808-00	CAP:0.1UF,10%,50 V
A8R681	315-0201-00	RES:200 OHM,5%,0.25W	C901	290-0720-00	CAP:68UF,20%,15 V
T501	037-2074-00	XFMR,POWER	C902	285-0808-00	CAP:0.1UF,10%,50 V
A8C676	DELETED	CAP:51PF,500V	C903	281-0775-00	CAP:0.1UF,20%,50 V
			C904	281-0773-00	CAP:0.01UF,10%,100 V
			C906	281-0811-00	CAP:10PF,10%,100 V
			C907	281-0814-00	CAP:100PF,10%,100 V
			C908	281-0775-00	CAP:0.1UF,20%,50 V
			C909	281-0791-00	CAP:270PF,10%,100 V
			C910	281-0763-00	CAP:47PF,10%,100 V
			C911	281-0788-00	CAP:470PF,10%,50 V
			C912	290-0301-00	CAP:10UF,10%,20 V
			C913	281-0788-00	CAP:470PF,10%,50 V
			C914	281-0773-00	CAP:0.01UF,10%,100 V
			C915	290-0267-00	CAP:1UF,20%,35 V
			C916	281-0773-00	CAP:0.01UF,10%,100 V
			C917	290-0720-00	CAP:68UF,20%,15 V
			C918	290-0267-00	CAP:1UF,20%,35 V
			C919	281-0773-00	CAP:0.01UF,10%,100 V
			C920	281-0773-00	CAP:0.01UF,10%,100 V
			C921	281-0788-00	CAP:470PF,10%,50 V
			C922	290-0267-00	CAP:1UF,20%,35 V
			C923	285-0918-00	CAP:1NF,5%,200 V
			C924	281-0593-00	CAP:3.9PF,±25PF,500 V
			C925	281-0788-00	CAP:470PF,10%,50 V
			C926	281-0812-00	CAP:1000PF,10%,100 V
			C927	281-0812-00	CAP:1000PF,10%,100 V
			C929	281-0775-00	CAP:0.1UF,20%,50V
			C930	281-0775-00	CAP:0.1UF,20%,50V
			C931	281-0763-00	CAP:47PF,10%,100V
			C932	281-0763-00	CAP:47PF,10%,100V
			C933	281-0763-00	CAP:47PF,10%,100V
			C934	281-0809-00	CAP:200PF,5%,100V
			C935	281-0763-00	CAP:47PF,10%,100V
			C936	281-0773-00	CAP:0.01UF,10%,100V
			C937	281-0809-00	CAP:20PF,5%,100V
			C938	290-0267-00	CAP:1UF,20%,35V
			C968	281-0775-00	CAP:0.1UF,20%,50V
			C989	281-0791-00	CAP:270PF,10%,100V
			C991	281-0772-00	CAP:4700PF,10%,100V
			C998	281-0811-00	CAP:10PF,10%,100V
			CR935	152-0141-00	DIODE:IN4152
			CR936	152-0141-00	DIODE:IN4152
			CR937	152-0141-00	DIODE:IN4152
			CR938	152-0141-00	DIODE:IN4152
			CR954	152-0141-00	DIODE:IN4152
Mod UC Electrical Parts List					
Ckt No.	Tektronix Part No.	Name and Description			
A4	037-6302-00	CKT BOARD ASSY:VERT MODE			
C381	283-0000-00	CAP:0.001UF,500V			
C391	283-0000-00	CAP:0.001UF,500V			
DS388	150-0035-00	LAMP,NEON			
DS389	150-0035-00	LAMP,NEON			
Q382	151-0435-00	TRANSISTOR:FMPSA65			
Q384	151-0188-00	TRANSISTOR:2N3906			
Q386	151-0301-00	TRANSISTOR:2N2907			
Q392	151-0435-00	TRANSISTOR:FMPSA65			
Q394	151-0188-00	TRANSISTOR:2N3906			
Q396	151-0301-00	TRANSISTOR:2N2907			
R377	315-0103-00	RES:10K OHM ¹			
R381	315-0152-00	RES:1.5K OHM			
R382	315-0473-00	RES:47K OHM			
R383	315-0222-00	RES:2.2K OHM			
R384	315-0822-00	RES:8.2K OHM			
R385	315-0103-00	RES:10K OHM			
R386	315-0103-00	RES:10K OHM			
R387	315-0103-00	RES:10K OHM			
R388	315-0154-00	RES:150K OHM			
R389	315-0154-00	RES:150K OHM			
R391	315-0152-00	RES:1.5K OHM			
R392	315-0473-00	RES:47K OHM			
R393	315-0222-00	RES:2.2K OHM			
R394	315-0822-00	RES:8.2K OHM			
R395	315-0103-00	RES:10K OHM			
R396	315-0103-00	RES:10K OHM			
R397	315-0103-00	RES:10K OHM			
R406	307-0446-00	RES.PACK:9X10K OHM			
S350	260-1424-01	SWITCH,5 POSN.			
U700	156-0382-01	MICROCKT:74LS00 PRE-TESTED			
U701	156-0386-01	MICROCKT:74LS10 PRE-TESTED			
U702	156-0382-01	MICROCKT:74LS00 PRE-TESTED			
U703	156-0388-01	MICROCKT:74LS74 PRE-TESTED			
U704	156-0916-00	MICROCKT:81LS97			
U705	156-0845-00	MICROCKT:8160			

¹All fixed resistor values are 5%, 0.25W unless otherwise indicated.

Ckt No.	Tektronix Part No.	Name and Description	Ckt No.	Tektronix Part No.	Name and Description
CR960	152-0141-00	DIODE:IN4152	R731	311-0605-00	RES.,VAR:200 OHM
CR962	152-0141-00	DIODE:IN4152	R732	351-0302-00	RES:3K OHM
CR964	152-0141-00	DIODE:IN4152	R740	315-0153-00	RES:15K OHM
CR965	152-0141-00	DIODE:IN4152	R741	315-0153-00	RES:15K OHM
CR966	152-0141-00	DIODE:IN4152	R745	315-0512-00	RES:5.1K OHM
CR967	152-0141-00	DIODE:IN4152	R901	315-0102-00	RES:1K OHM
CR968	152-0141-00	DIODE:IN4152	R902	315-0102-00	RES:1K OHM
CR972	152-0141-00	DIODE:IN4152	R904	315-0515-00	RES:150 OHM
CR973	152-0141-00	DIODE:IN4152	R905	315-0912-00	RES:9.1K OHM
CR974	152-0141-00	DIODE:IN4152	R910	307-0446-00	RES.PACK:9x10K OHM
CR981	152-0141-00	DIODE:IN4152	R911	315-0103-00	RES:10K OHM
Q900	151-0188-00	TRANSISTOR:2N3906	R912	315-0471-00	RES:470 OHM
Q904	151-0190-00	TRANSISTOR:2N3904	R913	315-0471-00	RES:470 OHM
Q906	151-0190-00	TRANSISTOR:2N3904	R914	315-0471-00	RES:470 OHM
Q908	151-0190-00	TRANSISTOR:2N3904	R916	315-0151-00	RES:150 OHM
Q910	151-0188-00	TRANSISTOR:2N3906	R917	315-0151-00	RES:150 OHM
Q912	151-0190-00	TRANSISTOR:2N3904	R918	315-0151-00	RES:150 OHM
Q913	151-0190-00	TRANSISTOR:2N3904	R920	307-0446-00	RES.PACK:9x10K OHM
Q914	151-0188-00	TRANSISTOR:2N3906	R921	315-0151-00	RES:150 OHM
Q916	151-0190-00	TRANSISTOR:2N3904	R922	315-0151-00	RES:150 OHM
Q918	151-0190-00	TRANSISTOR:2N3904	R923	315-0621-00	RES:620 OHM
Q920	151-0190-00	TRANSISTOR:2N3904	R924	315-0151-00	RES:150 OHM
Q922	151-0188-00	TRANSISTOR:2N3906	R925	315-0151-00	RES:150 OHM
Q984	151-0353-00	TRANSISTOR:1T121FMLY	R926	307-0542-00	RES.PACK:5x10K OHM
R700	321-0260-00	RES:4.99K OHM,1%,0.125W	R927	315-0621-00	RES:620 OHM
R702	311-1268-00	RES.,VAR:10K OHM	R928	315-0152-00	RES:1.5K OHM
R704	315-0751-00	RES:750 OHM ¹	R930	315-0152-00	RES:1.5K OHM
R705	315-0102-00	RES:1K OHM	R931	315-0822-00	RES:8.2K OHM
R706	315-0202-00	RES:2K OHM	R932	315-0822-00	RES:8.2K OHM
R708	315-0103-00	RES:10K OHM	R934	315-0474-00	RES:470 OHM
R710	321-0813-00	RES:495 OHM,1%,0.125W	R935	315-0153-00	RES:15K OHM
R711	321-0202-09	RES:1.24K OHM,1%,0.125W	R936	315-0104-00	RES:100K OHM
R712	321-0193-07	RES:1.00K OHM,1%,0.125W	R937	315-0302-00	RES:3K OHM
R713	321-0182-09	RES:768 OHM,0.1%,0.125W	R939	315-0302-00	RES:3K OHM
R714	311-1261-00	RES.,VAR:500 OHM	R940	311-1265-00	RES.,VAR:2K OHM
R715	321-0650-00	RES:650.4 OHM,1%,0.125W	R941	321-0259-00	RES:4.87K OHM,1%,0.125W
R716	321-0245-00	RES:3.48K OHM,1%,0.125W	R942	315-0304-00	RES:300K OHM
R718	315-0561-00	RES:560 OHM	R943	311-1261-00	RES.,VAR:500 OHM
R719	315-0103-00	RES:10K OHM	R944	315-0202-00	RES:2K OHM
R720	315-0202-00	RES:2K OHM	R945	315-0103-00	RES:10K OHM
R722	315-0272-00	RES:2.7K OHM	R946	321-0227-09	RES:2.26K OHM,0.1%,0.125W
R723	315-0302-00	RES:3K OHM	R947	321-0289-07	RES:10.0K OHM,0.1%,0.125W
R724	315-0133-00	RES:13K OHM	R949	321-0289-07	RES:10.0K OHM,0.1%,0.125W
R725	315-0132-00	RES:1.3K OHM	R950	321-0289-07	RES:10.0K OHM,0.1%,0.125W
R726	315-0133-00	RES:13K OHM	R951	321-0318-07	RES:20.0K OHM,0.1%,0.125W
R727	315-0273-00	RES:27K OHM	R953	315-0912-00	RES:9.1K OHM
R728	315-0562-00	RES:5.6K OHM	R954	315-0472-00	RES:4.7K OHM
R729	315-0133-00	RES:13K OHM	R955	315-0271-00	RES:270 OHM
R730	315-0272-00	RES:2.7K OHM	R956	315-0561-00	RES:560 OHM
			R958	315-0202-00	RES:2K OHM

¹ All fixed resistor values are 5%, 0.25W unless otherwise indicated.

Ckt No.	Tektronix Part No.	Name and Description	Ckt No.	Tektronix Part No.	Name and Description
R959	321-0335-00	RES:30.1K OHM,1%,0.125W	U910	156-0953-00	MICROCKT:74LS85
R960	315-0303-00	RES:30K OHM	U912	156-0953-00	MICROCKT:74LS85
R961	321-0202-00	RES:1.24K OHM,1%,0.125W	U914	156-0888-00	MICROCKT:75494
R962	321-0202-00	RES:1.24K OHM,1%,0.125W	U916	156-0795-00	MICROCKT:4511
R963	321-0369-00	RES:68.1K OHM,1%,0.125W	U918	156-1118-00	MICROCKT:14433
R964	321-0261-00	RES:5.11K OHM,1%,0.125W	U920	156-0113-00	MICROCKT:74L00
R965	315-0303-00	RES:30K OHM	U922	156-0385-00	MICROCKT:74LS04
R966	311-1259-00	RES.,VAR:100 OHM	U924	156-0388-00	MICROCKT:74LS74
R967	321-0097-00	RES:100 OHM,1%,0.125W	U926	156-0388-00	MICROCKT:74LS74
R968	321-0281-00	RES:8.25K OHM,1%,0.125W	U928	156-0514-00	MICROCKT:4052
R969	315-0103-00	RES:10K OHM ¹	U930	156-0385-00	MICROCKT:74LS04
R970	311-0644-00	RES.,VAR:20K OHM	U932	156-0910-00	MICROCKT:74LS390
R971	315-0123-00	RES:12K OHM	U934	156-1172-00	MICROCKT:74LS393
R973	315-0183-00	RES:18K OHM	U936	156-0910-00	MICROCKT:74LS390
R974	321-0222-00	RES:2.00K OHM,1%,0.125W	U938	156-1172-00	MICROCKT:74LS393
R976	321-0222-00	RES:2.00K OHM,1%,0.125W	U940	037-3026-00	MICROCKT:ADC 80AG-10
R977	321-0231-00	RES:2.49K OHM,1%,0.125W	U942	156-0916-00	MICROCKT:81LS97
R978	321-0164-00	RES:499 OHM,1%,0.125W	U944	156-0967-00	MICROCKT:AD561
R980	321-0162-00	RES:475 OHM,1%,0.125W	U946	156-0927-00	MICROCKT:MC3410
R981	321-0177-00	RES:681 OHM,1%,0.125W	U948	156-0893-00	MICROCKT:2102A
R982	321-0189-00	RES:909 OHM,1%,0.125W	U950	156-0893-00	MICROCKT:2102A
R983	311-1261-00	RES.,VAR:500 OHM	U952	156-1027-00	MICROCKT:2114L
R984	321-0170-00	RES:576 OHM,1%,0.125W	U954	156-1027-00	MICROCKT:2114L
R985	321-0068-00	RES:49.9 OHM,1%,0.125W	U956	156-0733-00	MICROCKT:74LS221
R986	315-0102-00	RES:1K OHM	U958	156-0388-00	MICROCKT:74LS74
R987	315-0821-00	RES:820 OHM	U960	156-0470-00	MICROCKT:74LS251
R988	311-1476-00	RES.,VAR:10K OHM	U962	156-0875-00	MICROCKT:74LS51
R989	315-0683-00	RES:68K OHM	U963	156-0727-00	MICROCKT:74LS196
R990	311-1150-00	RES.,VAR:10K OHM	U964	156-0385-00	MICROCKT:74LS04
R991	315-0104-00	RES:100K OHM	U966	156-0480-00	MICROCKT:74LS08
R992	311-1150-00	RES.,VAR:10K OHM	U968	156-0382-00	MICROCKT:74LS00
R993	311-1265-00	RES.,VAR:2K OHM	U970	156-0388-00	MICROCKT:74LS74
R994	321-0260-00	RES:4.99K OHM,1%,0.125W	U971	156-0388-00	MICROCKT:74LS74
R995	315-0303-00	RES:30K OHM	U972	156-0733-00	MICROCKT:74LS221
R996	315-0303-00	RES:30K OHM	U974	156-0515-00	MICROCKT:4053
R997	321-0185-00	RES:825 OHM,1%,0.125W	U976	156-0382-00	MICROCKT:74LS00
R999	311-1262-00	RES.,VAR:750 OHM	U977	037-3027-00	MICROCKT:LF398
RT963	307-0181-00	THERMISTOR:100K OHM	U978	156-0511-00	MICROCKT:NE531
RT987	307-0124-00	THERMISTOR:5K OHM	U980	156-0511-00	MICROCKT:NE531
S900	260-1211-00	SWITCH,PUSH	U981	156-0197-00	MICROCKT:3086
S904	260-1211-00	SWITCH,PUSH	U982	156-0511-00	MICROCKT:NE531
S906	260-1571-00	SWITCH,PUSH	U983	156-1173-00	MICROCKT:1403
S908	260-1571-00	SWITCH,PUSH	U984	156-0511-00	MICROCKT:NE531
S910	260-1571-00	SWITCH,PUSH	U986	156-0511-00	MICROCKT:NE531
U900	156-0913-00	MICROCKT:74LS377	U988	156-0514-00	MICROCKT:4052
U902	156-0916-00	MICROCKT:81LS97	U990	156-0158-00	MICROCKT:1458
U904	156-0905-00	MICROCKT:93427	U992	156-0515-00	MICROCKT:4053
U906	156-0384-00	MICROCKT:74LS03	U994	156-0514-00	MICROCKT:4052
U908	156-0718-00	MICROCKT:74LS27	U995	156-0158-00	MICROCKT:1458
			U996	156-1173-00	MICROCKT:1403
			U997	156-0158-00	MICROCKT:1458
			U998	156-0096-00	MICROCKT:LM311

¹ All fixed resistors values are 5%,0.25W unless otherwise indicated.

Ckt No.	Tektronix Part No.	Name and Description	Ckt No.	Tektronix Part No.	Name and Description
VR927	152-0514-00	DIODE:10V,IN961B	A13	037-6306-00	CKT BOARD ASSY: REGULATOR
VR939	152-0514-00	DIODE:10V,IN961B	C2612	290-0325-00	CAP:330UF,+75-10%,50V
Y100	158-0056-00	CRYSTAL:4 MHZ	C2613	283-0198-00	CAP:0.22UF,20%,20V
			C2615	290-0527-00	CAP:15UF,20%,20V
			C2622	290-0760-00	CAP:2200UF,+50-10%,25V
			C2623	290-0760-00	CAP:2200UF,+50-10%,25V
			C2624	283-0198-00	CAP:0.22UF,20%,50V
			C2626	290-0527-00	CAP:15UF,20%,20V
			C2632	290-0325-00	CAP:330UF,+75-10%,50V
			C2634	290-0534-00	CAP:1UF,20%,35V
			C2636	290-0527-00	CAP:15UF,20%,20V
A12	037-6303-00	CKT BOARD ASSY: READOUT	CR2610	152-0488-00	RECT:200V,1.5A
CR1700	150-1001-00	LED	CR2622	152-0423-00	RECT:300V,3A
CR1710	150-1001-00	LED	CR2623	152-0423-00	RECT:300V,3A
CR1720	150-1001-00	LED	CR2636	152-0066-00	RECT:400V,0.75A
U1700	150-1011-01	LED DISPLAY	Q2632	151-0190-00	TRANSISTOR:2N3904
U1710	150-1011-01	LED DISPLAY	Q2634	151-0188-00	TRANSISTOR:2N3906
U1720	150-1011-01	LED DISPLAY	Q2636	151-0464-00	TRANSISTOR:RCA29C
U1730	150-1011-01	LED DISPLAY	Q2638	151-0188-00	TRANSISTOR:2N3906
			R2633	307-0105-00	RES:3.9 OHM ¹
			R2634	321-0274-00	RES:6.98K OHM,1%,0.125W
			R2635	321-0274-00	RES:6.98K OHM,1%,0.125W
			R2636	315-0392-00	RES:3.9K OHM
			U2614	156-0312-00	MICROCKT: 7815
			U2624	156-0277-00	MICROCKT: 7805

¹All fixed resistor values are 5%,0.25W unless otherwise indicated.

REPLACEABLE MECHANICAL PARTS

ECB Ass'y 037-6302-00 Vertical Mode Board—A4

QTY	PART NUMBER	DESCRIPTION
2	030-0948-03	VOLTS/DIV Cam switch assembly
1	030-0951-03	ECB assembly
1	030-0907-04	Actuator, switch (subpart of 030-0951-03)
1	034-4112-00	ECB
2	105-0243-00	Switch actuator
2	105-0282-01	Actuator
1	105-0824-00	Actuator, cam switch (subpart of 030-0948-03)
20	131-0608-00	Sq. pin, .365" long
4	131-0963-00	Ground contact
8	131-1031-00	Switch contact
1	136-0260-02	16 pin IC socket
4	136-0269-02	14 pin, IC socket
1	136-0634-00	20 pin IC socket
8	210-0406-00	Nut, 4-40 x .187"
8	210-0779-00	Rivet
2	210-1189-00	Flat washer
2	210-1266-00	Flat washer
1	351-0355-00	Switch, guide
2	384-1477-01	Shaft (subpart of 030-0048-03)
2	384-1478-01	Shaft (subpart of 384-1477-01)
12	211-0207-00	Screw, 4-40 x .312"
2	213-0214-00	Screw, 2-56 x .375"
4	214-1139-00	Flat spring
4	214-1752-00	Roller
2	214-2043-00	Spring
2	352-0331-00	Lampholder
2	354-0390-00	Retaining ring
4	361-0411-00	Switch spacers
2	384-0878-02	Shaft
2	401-0180-00	Bearing

ECB Ass'y 037-6304-00, Main Board—A11

Qty.	Part Number	Description
2	030-0945-03	Pot bracket
1	034-4114-00	ECB
2	036-1163-00	16 pin strip socket
1	124-0050-00	Foam tape, 7/16" long
38	131-0608-00	Sq. pin terminal .365" long
8	131-1003-00	Peltola shell
1	131-1632-00	20 pin connector (side entry)
8	136-0254-04	Berg socket
17	136-0260-02	16 contact IC socket
15	136-0269-02	14 contact IC socket
12	136-0514-00	8 contact IC socket
1	136-0578-00	24 contact IC socket
2	136-0598-00	18 contact IC socket
3	136-0634-00	20 contact IC socket
2	210-0046-00	1/4" lock washer
2	210-0465-00	1/4 - 32 x 3/8" nut
1	346-0032-00	Tie down
2	348-0430-00	Foot, adhesive back
16	361-0411-00	Switch spacer

ECB Ass'y Readout Board 037-6303-00—A12

Qty	Part Number	Description
1	034-4113-00	ECB
20	131-0589-00	Sq. pin .355"
2	211-0180-00	Screw, 2-56 x .25"

ECB Ass'y 037-6306-00, Regulator Board—A13

Qty.	Part Number	Description
9	136-0252-04	Berg socket
2	210-0201-00	#4 solder lug
3	210-0938-00	Washer, .109 ID x .25" OD
3	211-0008-00	Screw, 4-40 x .25"
2	211-0207-00	Screw, 4-40 x .312"
3	210-0586-00	Nut, 4-40 x .25"
1	342-0195-00	Insulator
1	343-0507-00	Retainer
1	348-0055-00	.25" grommet
1	348-0063-00	.50" grommet
1	388-3982-00	ECB
1	441-1171-00	Chassis

Final Kit

Qty.	Part Number	Description
1	031-0178-00	Trigger Mode Switch
1	034-0811-00	Front panel
1	036-3144-00	Knob w/shaft (STORED DISPLAY IN)
1	131-0566-00	Dummy resistor
2	152-0141-02	Diode, IN4125
2	162-0503-00	Insulation 1" long
3	162-0589-00	Heat shrink insulation, 1 1/8" long
1	162-0589-00	Heat shrink insulation, 1/2" long
1	200-1722-01	Cabinet top
2	210-0201-00	#4 solder lug
2	210-0803-00	Washer, flat .150"
2	211-0507-00	6-32 x .312" screw
6	211-0116-00	4-40 x .312" screw
2	213-0146-00	Screw, thread forming, 6-20 x .312"
1	407-1568-00	Bracket
5	426-1072-00	Frame
1	426-1176-00	Front frame
1	437-0174-00	Cabinet
1	331-0397-00	Window, display
1	342-0239-00	Insulator plate
1	348-0417-00	Grommet, oblong ring
3	358-0378-00	Bushing
2	366-1028-00	Knob
1	366-1028-01	Knob w/dot
5	366-1559-00	Pushbutton
2	376-0029-00	Coupling
1	384-0488-00	Shaft
1	384-1174-00	Shaft
1	386-3108-00	ECB Support

Accessories

465 Mod UC is supplied with the standard 465 accessories plus:

1 010-6105-03 10X Probe: P6105,w/access

The accessory pouch supplied is Tektronix part no. 016-0594-00.

DIAGRAMS AND CIRCUIT BOARD ILLUSTRATIONS

Symbols and Reference Designators

Electrical components shown on the diagrams are in the following units unless noted otherwise:

- Capacitors = Values one or greater are in picofarads (pF).
Values less than one are in microfarads (μF).
- Resistors = Ohms (Ω).

Graphic symbols and class designation letters are based on ANSI Standard Y32.2-1975.

Logic symbology is based on ANSI Y32.14-1973 in terms of positive logic. Logic symbols depict the logic function performed and may differ from the manufacturer's data.

The overline on a signal name indicates that the signal performs its intended function when it goes to the low state.

Abbreviations are based on ANSI Y1.1-1972.

Other ANSI standards that are used in the preparation of diagrams by Tektronix, Inc. are:

- Y14.15, 1966 Drafting Practices.
- Y14.2, 1973 Line Conventions and Lettering.
- Y10.5, 1968 Letter Symbols for Quantities Used in Electrical Science and Electrical Engineering.

The following prefix letters are used as reference designators to identify components or assemblies on the diagrams.

A	Assembly, separable or repairable (circuit board, etc)	H	Heat dissipating device (heat sink, heat radiator, etc)	S	Switch or contactor
AT	Attenuator, fixed or variable	HR	Heater	T	Transformer
B	Motor	HY	Hybrid circuit	TC	Thermocouple
BT	Battery	J	Connector, stationary portion	TP	Test point
C	Capacitor, fixed or variable	K	Relay	U	Assembly, inseparable or non-repairable (integrated circuit, etc.)
CB	Circuit breaker	L	Inductor, fixed or variable	V	Electron tube
CR	Diode, signal or rectifier	M	Meter	VR	Voltage regulator (zener diode, etc.)
DL	Delay line	P	Connector, movable portion	W	Wirestrap or cable
DS	Indicating device (lamp)	Q	Transistor or silicon-controlled rectifier	Y	Crystal
E	Spark Gap, Ferrite bead	R	Resistor, fixed or variable	Z	Phase shifter
F	Fuse	RT	Thermistor		
FL	Filter				

The following special symbols may appear on the diagrams:

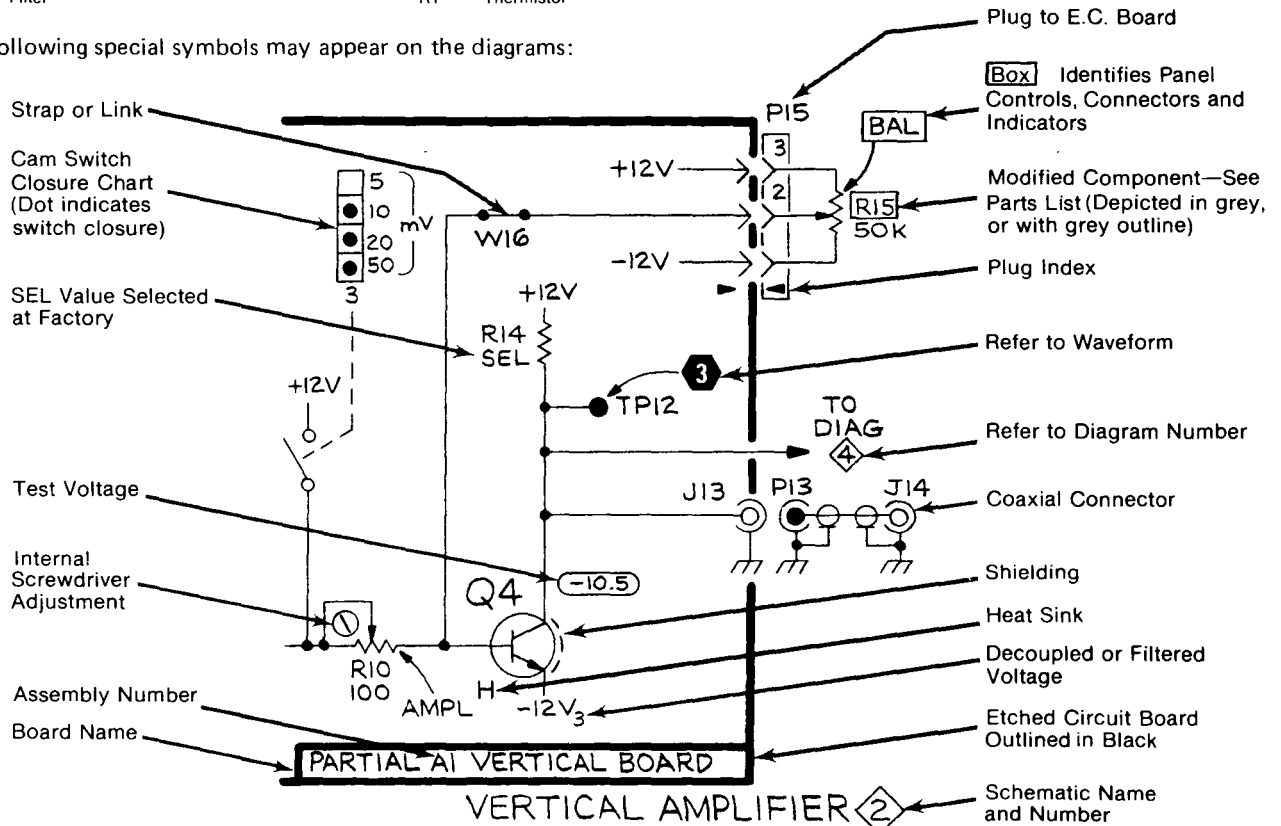

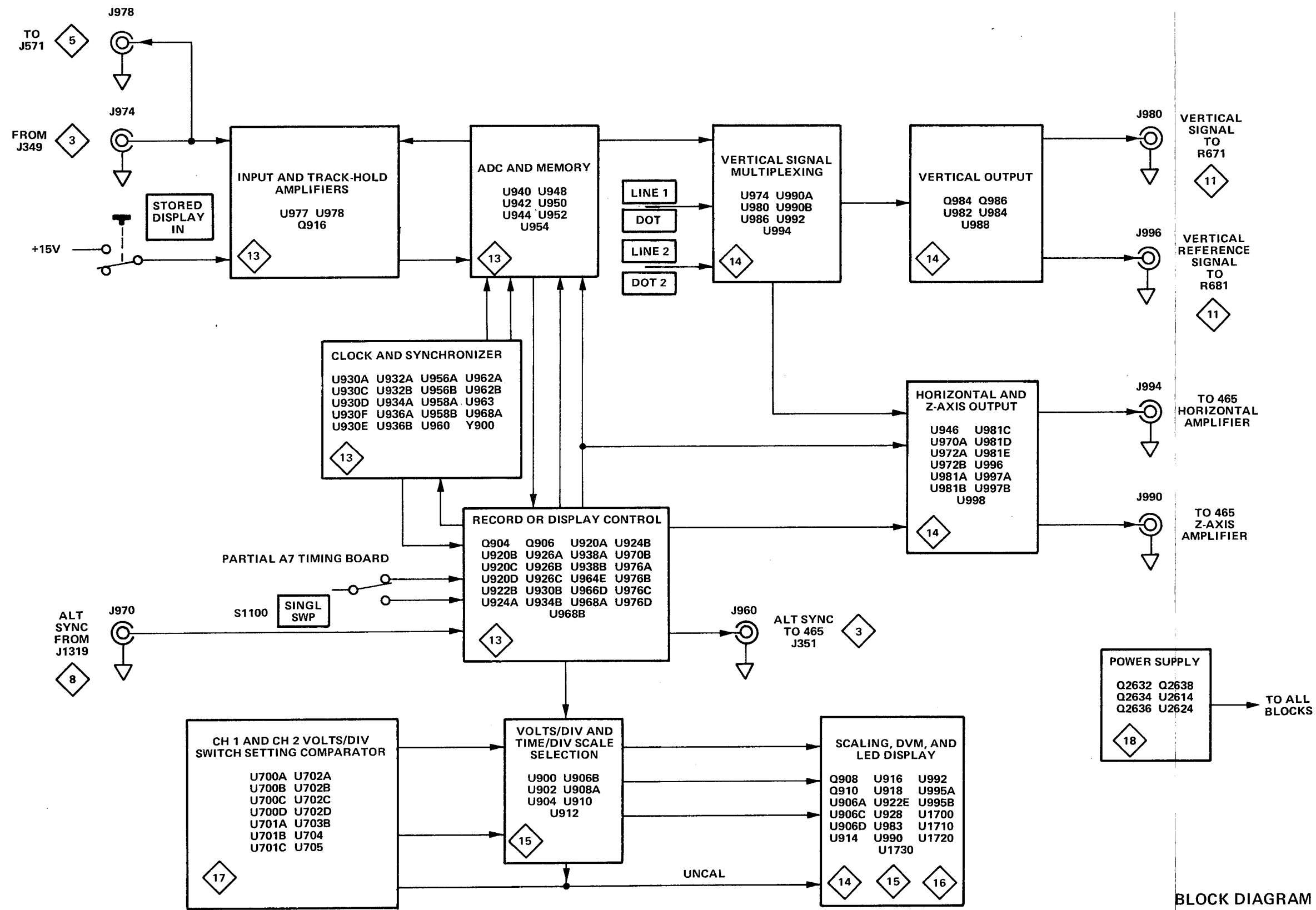

BLOCK DIAGRAM

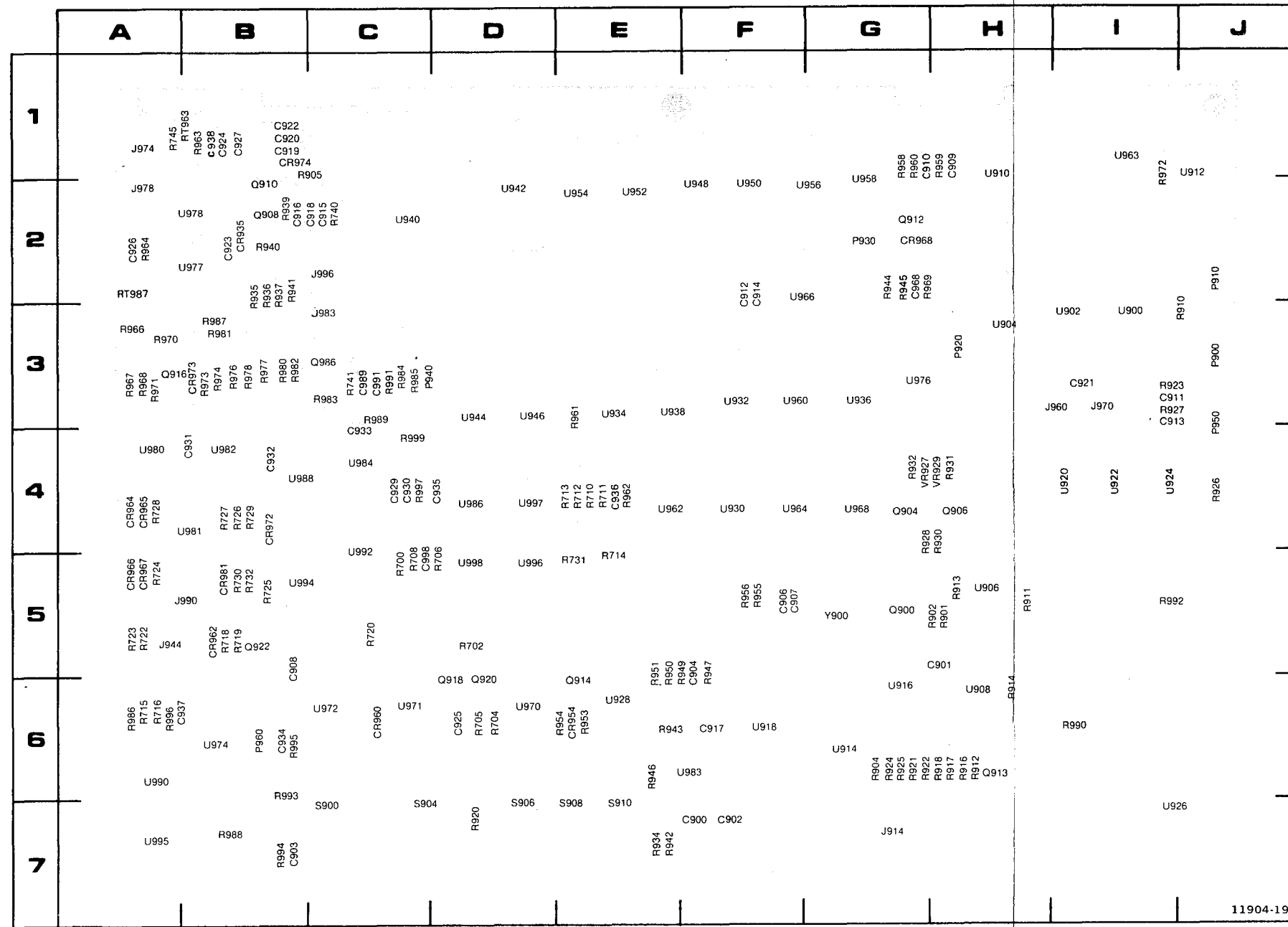
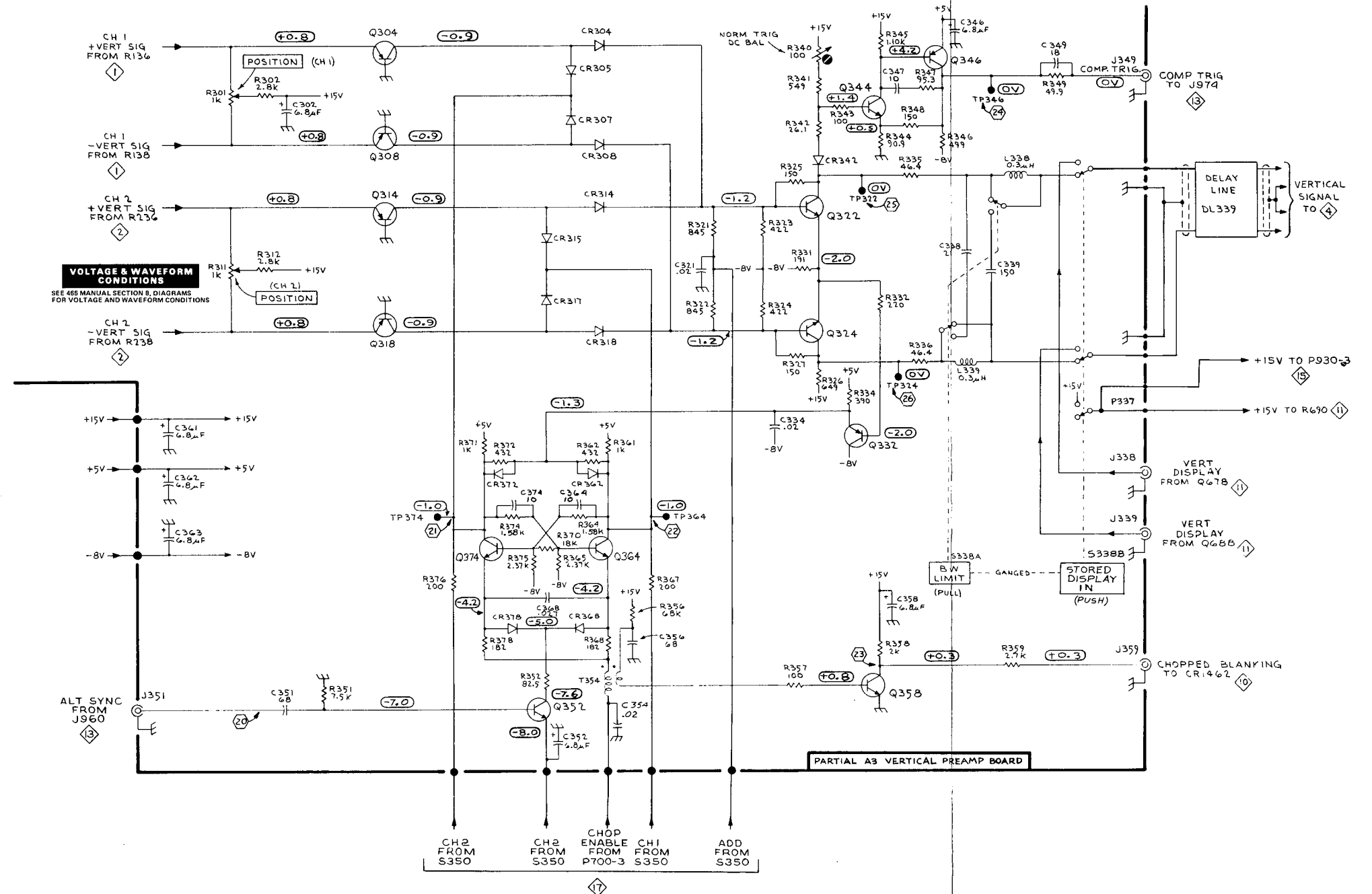

Figure 20. Digital Storage Mod UC main board components.

*CR937, CR938, R965
LOCATED BACK SIDE
OF BOARD

CKT NO	GRID LOC	CKT NO	GRID LOC	CKT NO	GRID LOC	CKT NO	GRID LOC	CKT NO	GRID LOC
C900	7F	J983	3C	R913	5H	R986	6A	U974	6B
C901	5H	J990	5B	R914	6H	R987	3B	U976	3G
C902	7F	J996	2C	R916	6H	R988	7B	U977	2B
C903	7B	P900	3J	R917	6H	R989	3C	U978	2B
C904	5F	P910	2J	R918	6H	R990	6I	U980	4A
C906	5F	P920	3H	R920	7D	R991	3C	U981	4B
C907	5F	P930	2G	R921	6G	R992	5I	U982	4B
C908	5B	P940	3C	R922	6G	R993	6B	U983	6F
C909	1H	P950	3J	R923	3I	R994	7B	U984	4C
C910	1G	P960	6B	R924	6G	R995	6B	U986	4D
C911	3I			R925	6G	R996	6A	U988	4B
C912	2F	Q900	5G	R926	4J	R997	4C	U990	6A
C913	3I	Q904	4G	R927	3I	R999	4C	U992	5C
C914	2F	Q906	4H	R928	4G			U994	5B
C915	2C	Q908	2B	R931	4H	RT963	1B	U995	7A
C916	2B	Q910	2B	R932	4G	RT987	2A	U996	5D
C917	6F	Q912	2G	R934	7E			U997	4D
C918	2C	Q913	6H	R936	2B	S900	7C	U998	5D
C919	1B	Q914	6E	R937	2B	S904	7C		
C920	1B	Q916	3A			S906	7D	VR927	4G
C921	3I	Q918	6D	R939	2B	S908	7E	VR929	4H
C922	1B	Q920	6D	R940	2B	S910	7E		
C923	2B	Q922	5B	R941	2B			Y900	5G
C924	1B	Q984	3C	R942	7E	U900	3I		
C925	6D			R943	6E	U902	3I		
C926	2A	R700	5C	R944	2G	U904	3H		
C927	1B	R702	5D	R945	2G	U906	5H		
C929	4C	R704	6D	R946	6E	U908	6H		
C930	1B	R705	6D	R947	5F	U910	1H		
C930	4C	R706	5D	R949	5E	U912	1J		
C931	4B	R708	5C	R950	5E	U914	6G		
C932	4B	R710	4E	R951	5E	U916	6G		
C933	4C	R711	4E	R953	6E	U918	6F		
C934	6B	R712	4E	R954	6E	U920	4I		
C935	4D	R713	4E	R955	5F	U922	4I		
C936	4E	R714	5E	R956	5F	U924	4I		
C937	6A	R715	6A	R958	1G	U926	7I		
C938	1B	R716	6A	R959	1H	U928	6E		
C968	2G	R718	5B	R960	1G	U930	4F		
C989	3C	R719	5B	R960	5E	U932	3F		
C998	5C	R720	5C	R961	3E	U934	3E		
CR935	2B	R722	5A	R962	4E	U936	3G		
CR954	6E	R723	5A	R963	1B	U938	3E		
CR960	6C	R724	5A	R964	3A	U940	2C		
CR962	5B	R725	5B	R966	3A	U942	2D		
CR964	4A	R726	4B	R967	3A	U944	3D		
CR965	4A	R727	4B	R968	3A	U946	3D		
CR966	5A	R728	4A	R969	2G	U948	2F		
CR967	5A	R729	4B	R970	3A	U950	2F		
CR968	2G	R730	5B	R971	3A	U952	2E		
CR972	4B	R731	5E	R972	1I	U954	2E		
CR973	3B	R732	5B	R973	3B	U956	2G		
CR974	1B	R740	2C	R974	3B	U958	2G		
CR981	5B	R741	3C	R976	3B	U960	3F		
		R745	1A	R977	3B	U962	4E		
J914	7G	R901	5H	R978	3B	U963	1I		
J944	5A	R902	5H	R980	3B	U964	4F		
J960	3I	R904	6G	R981	3B	U966	2G		
J970	3I	R905	1C	R982	3B	U968	4G		
J974	1A	R910	3J	R983	3C	U970	6D		
J978	2A	R911	5H	R984	3C	U971	6C		
J980	3C	R912	6H	R985	3C	U972	6C		



SEE PARTS LIST FOR SEMICONDUCTOR TYPES.

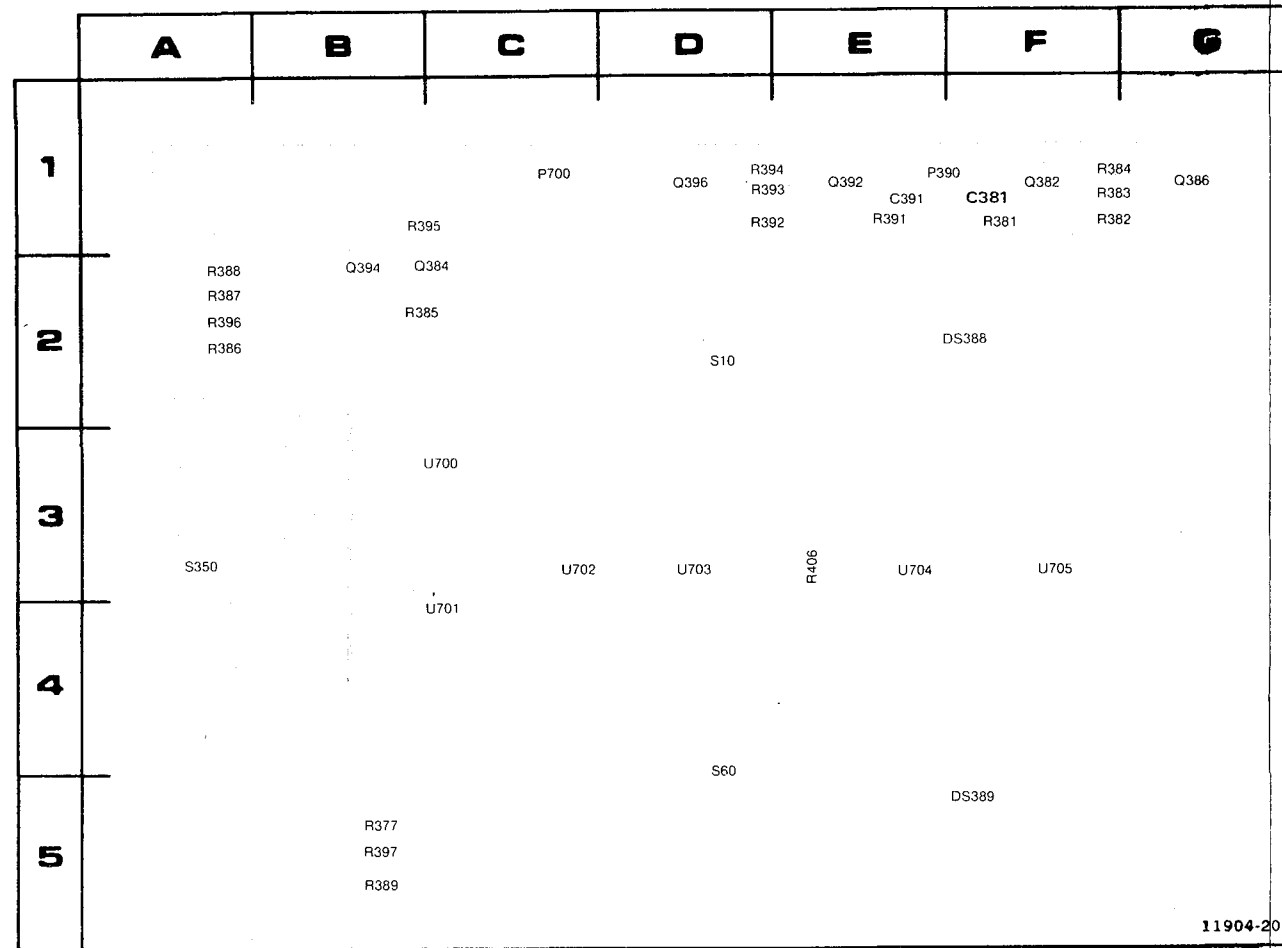

Figure 21. A4-Vertical Mode Switching board components.

CKT NO	GRID LOC	CKT NO	GRID LOC
C391	1E	R387	2A
C381	1F	R388	2A
DS388	2F	R389	5B
DS389		R391	1E
		R382	1D
P390	1F	R393	1D
P700	1C	R394	1D
		R395	1C
Q382	1F	R396	2A
Q384	2C	R397	5B
Q386	1G	R406	3F
Q392	1E		
Q394	2B	S10	2D
Q396	1D	S60	4D
		S350	3A
R377	5B		
R381	1F	U700	3C
R382	1F	U701	4C
R383	1F	U702	3C
R384	1F	U703	3D
R385	2C	U704	3F
R386	2A	U705	3F

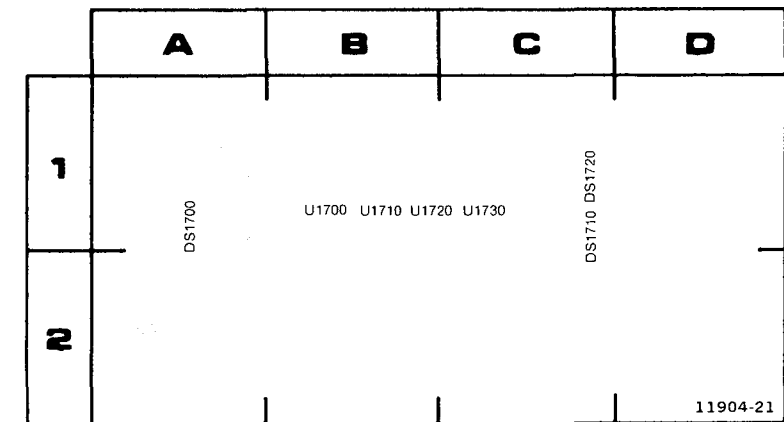
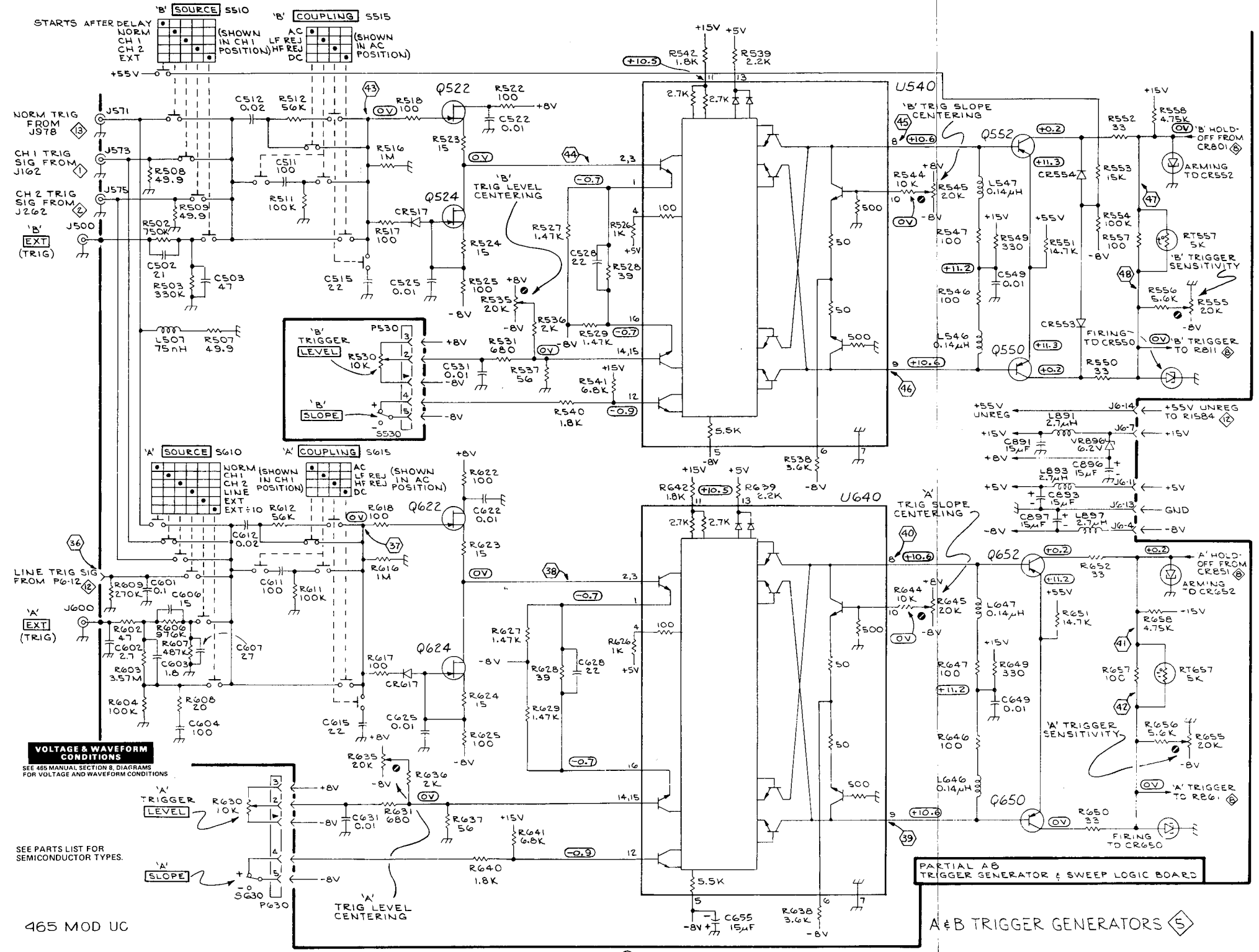

Figure 22. A12-Readout board components.

CKT NO	GRID LOC
DS1700	1A
DS1710	1C
DS1720	1C
U1700	1B
U1710	1B
U1720	1B
U1730	1C



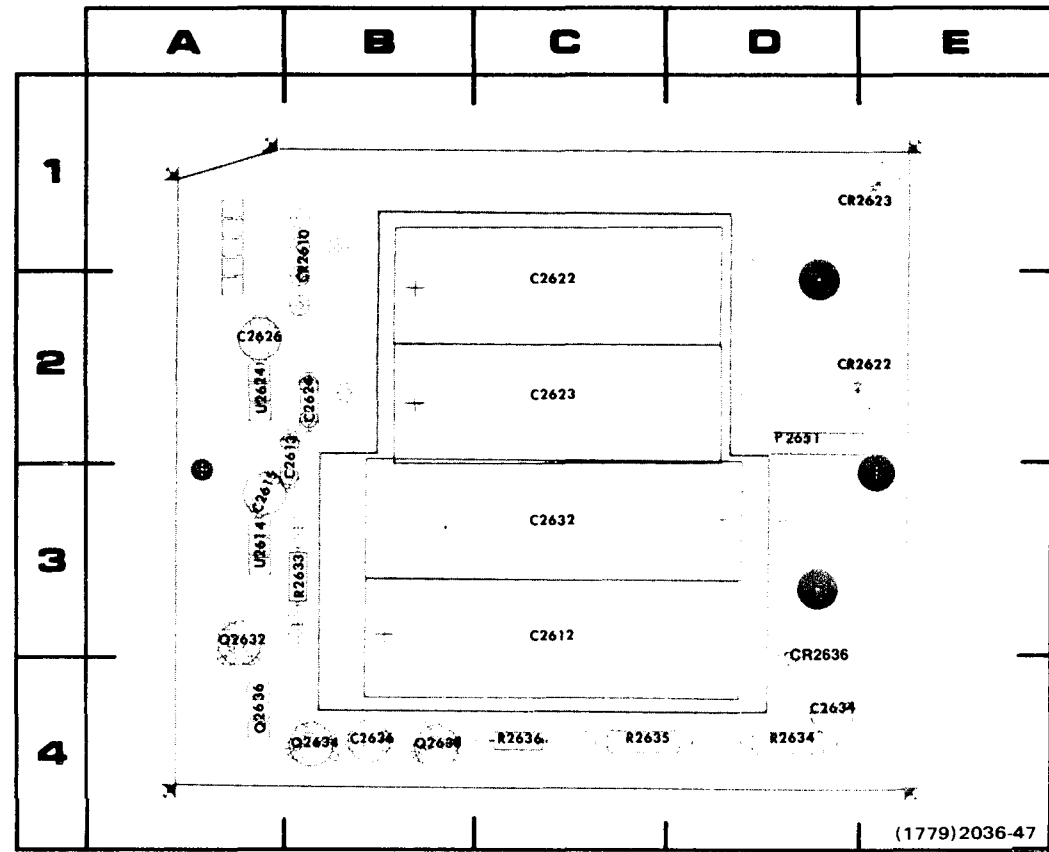
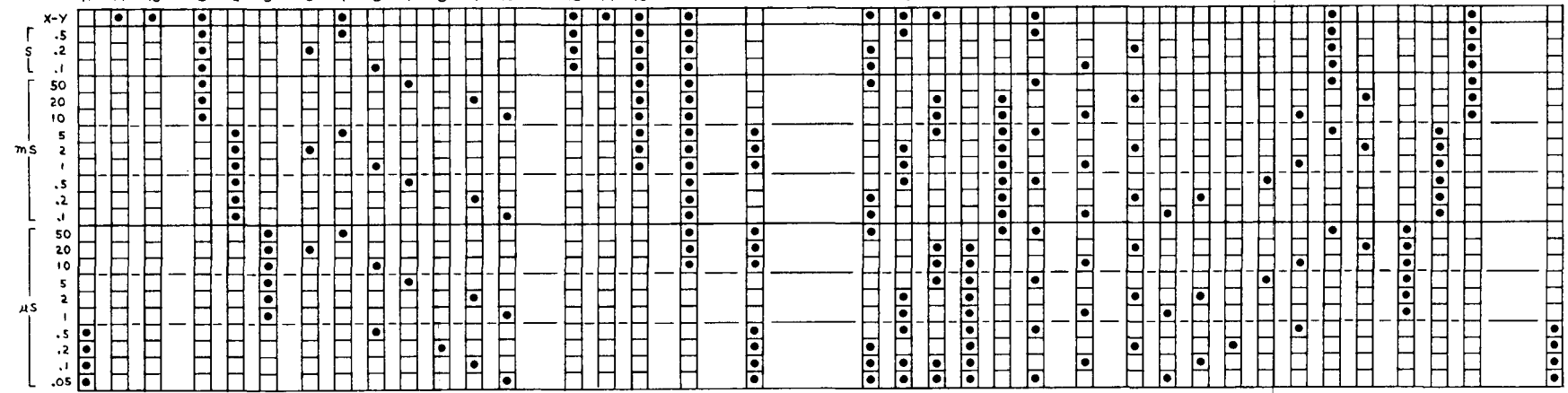
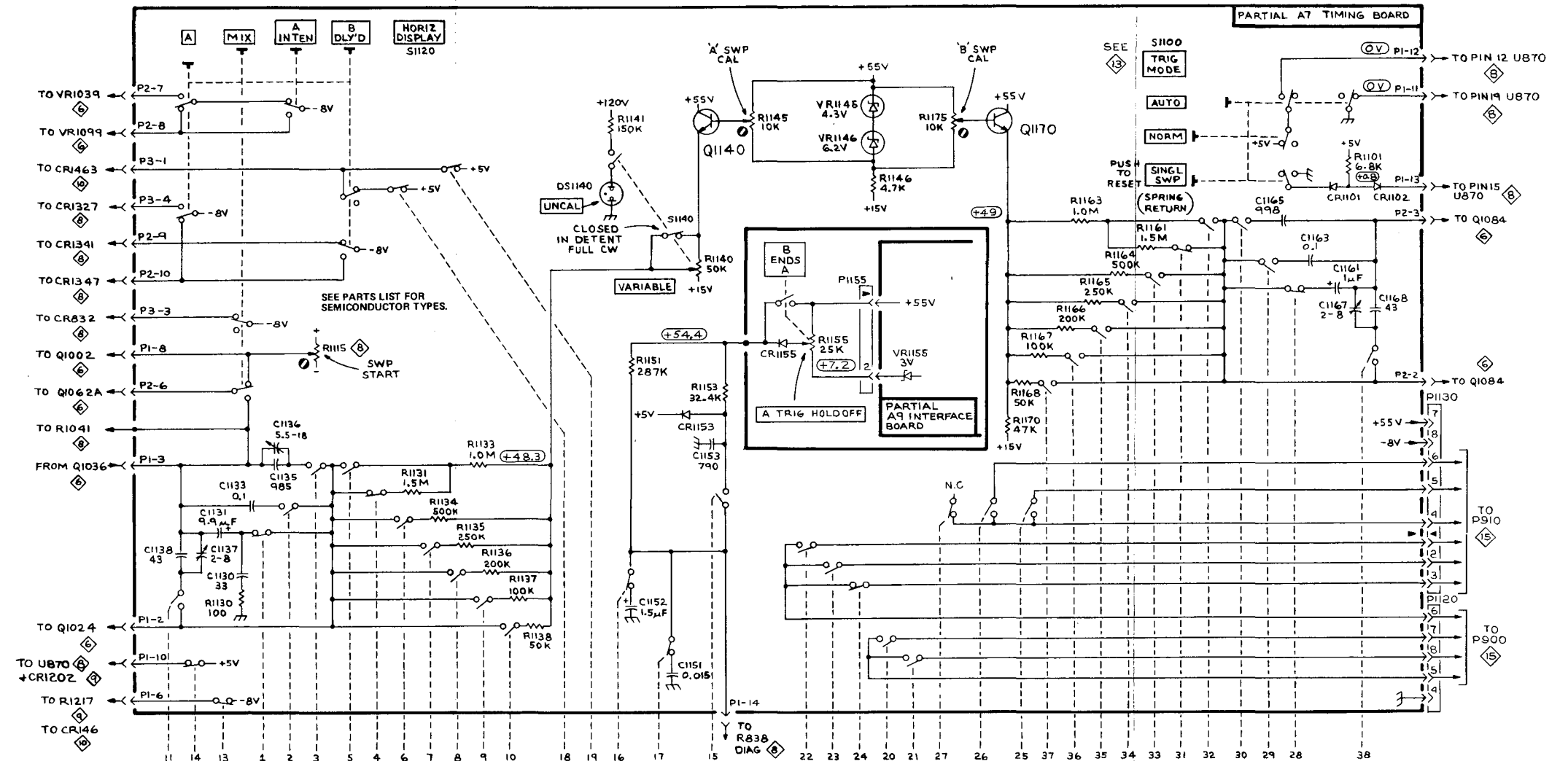

Figure 23. A13-Regulator board components.

CKT NO	GRID LOC	CKT NO	GRID LOC
C2612	3C	P2651	2D
C2613	2B		
C2615	3A	Q2632	3A
C2622	2C	Q2634	4B
C2623	2C	Q2636	4A
C2624	2B	Q2638	4B
C2626	2A		
C2632	3C	R2633	3B
C2634	4D	R2634	4D
C2636	4B	R2635	4C
		R2636	4C
CR2610	1B		
CR2622	2E	U2614	3A
CR2623	1E	U2624	2A
CR2636	3D		



465 MOD UC

A AND B TIME/DIV AND DELAY TIME

A & B TIMING SWITCH

465 MOD UC

VOLTAGE & WAVEFORM CONDITIONS
 SEE 465 MANUAL, SECTION 8, DIAGRAMS
 FOR VOLTAGE AND WAVEFORM CONDITIONS

①

②

SWEEP & Z AXIS LOGIC

③

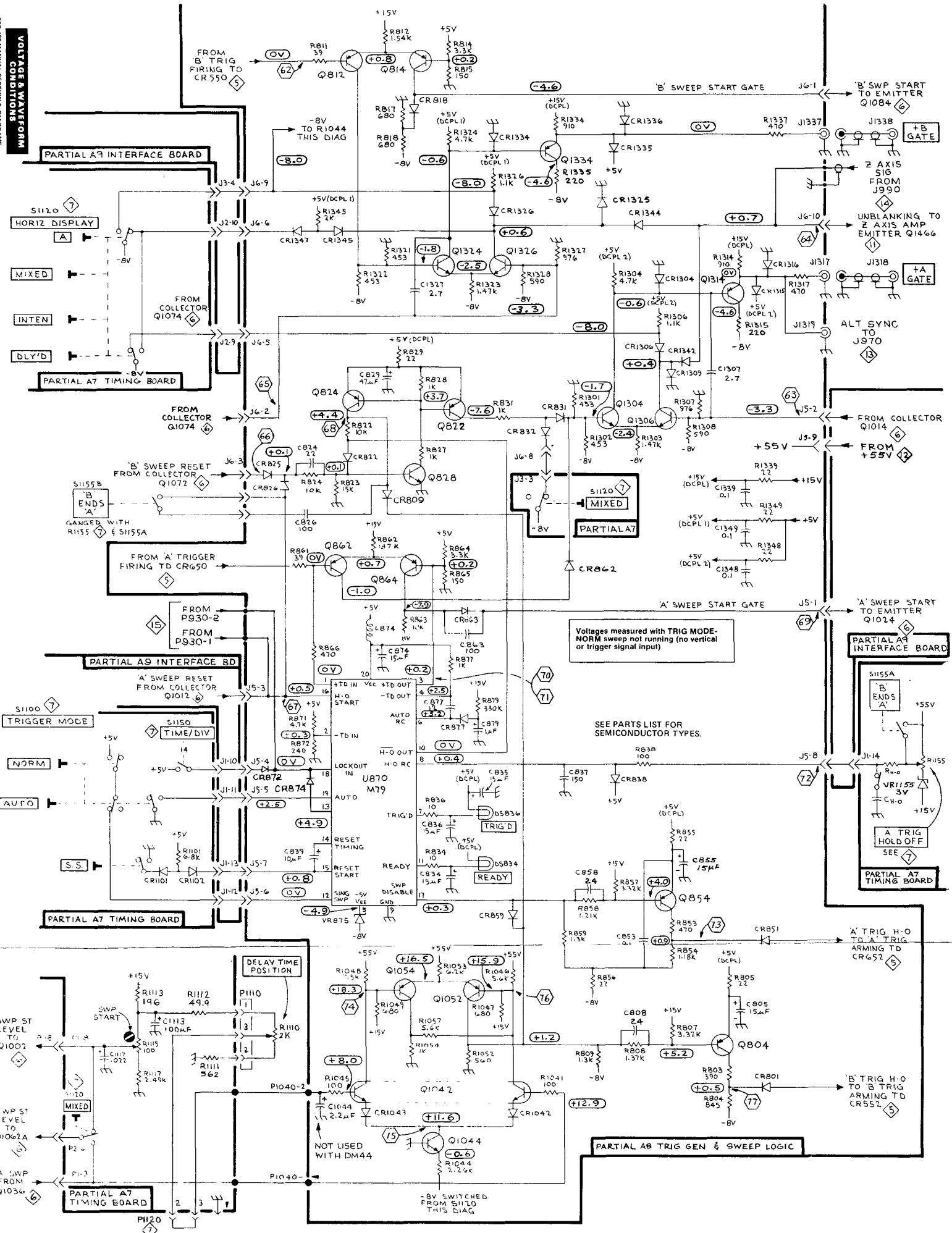

VOLTAGE & WAVEFORM CONDITIONS

SEE 465 MANUAL SECTION 8, DIAGRAMS FOR VOLTAGE AND WAVEFORM CONDITIONS

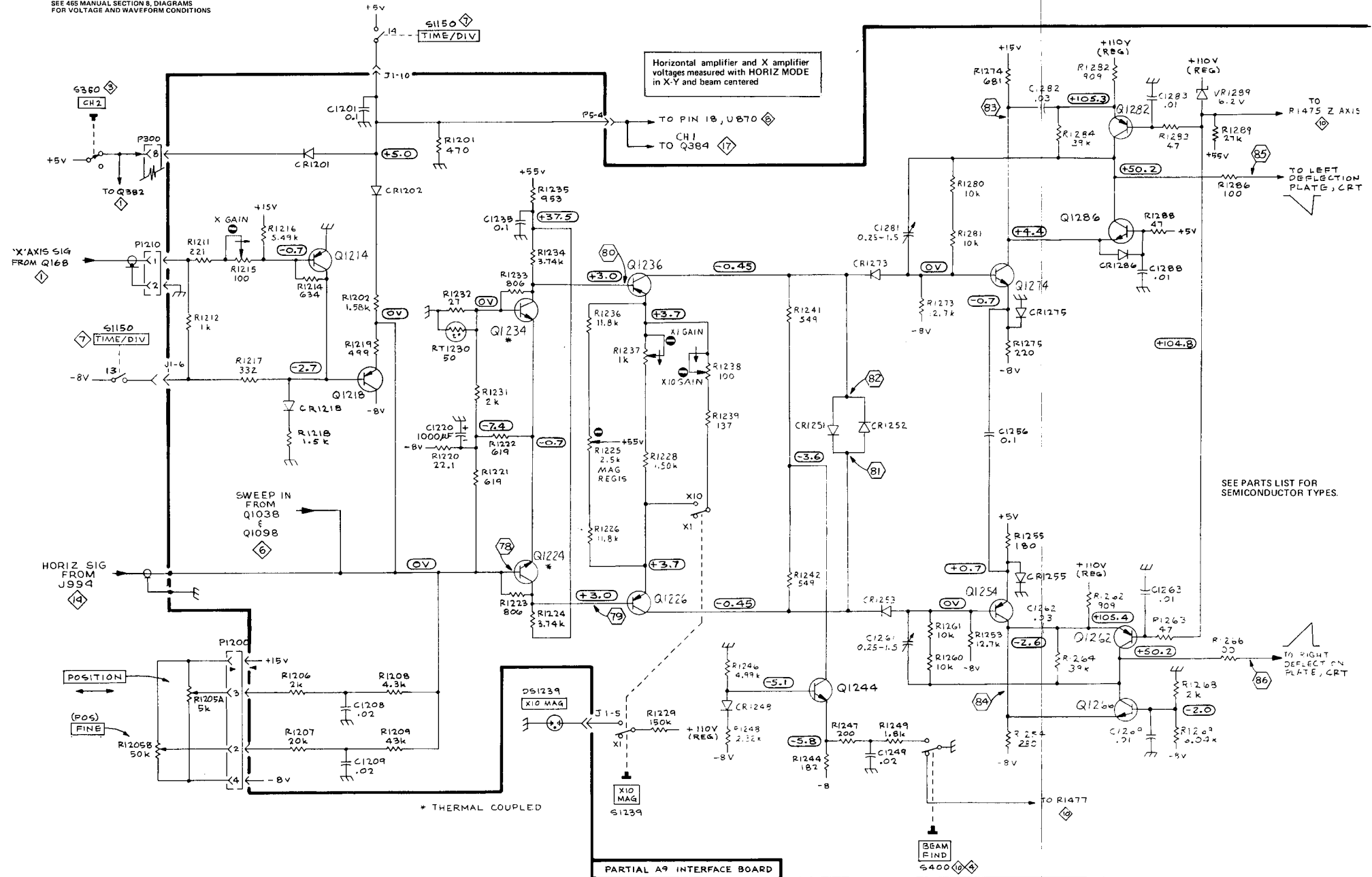

465 MOD UC

@

HORIZONTAL AMPLIFIER

VOLTAGE & WAVEFORM CONDITIONS
SEE 465 MANUAL, SECTION 8, DIAGRAMS FOR VOLTAGE AND WAVEFORM CONDITIONS

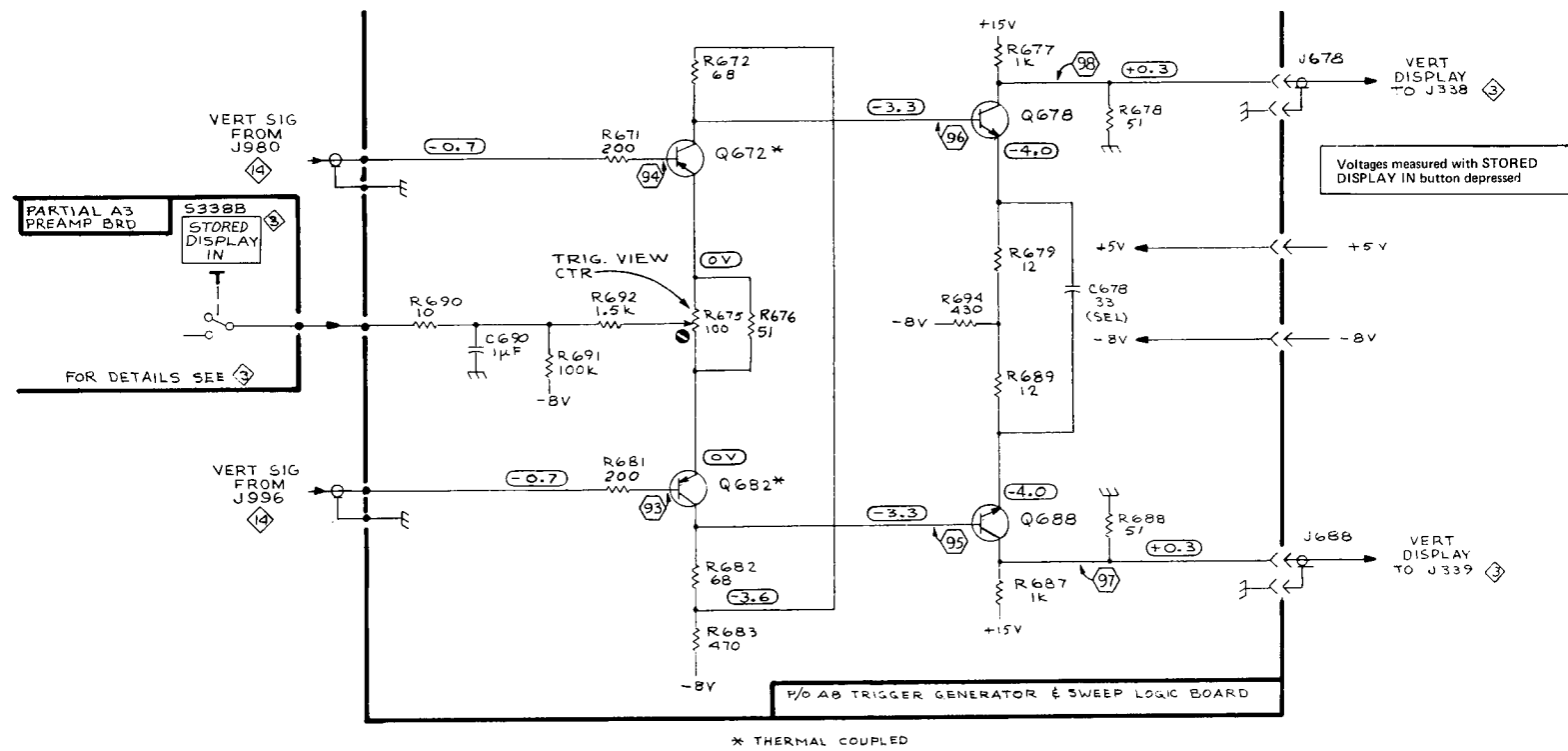
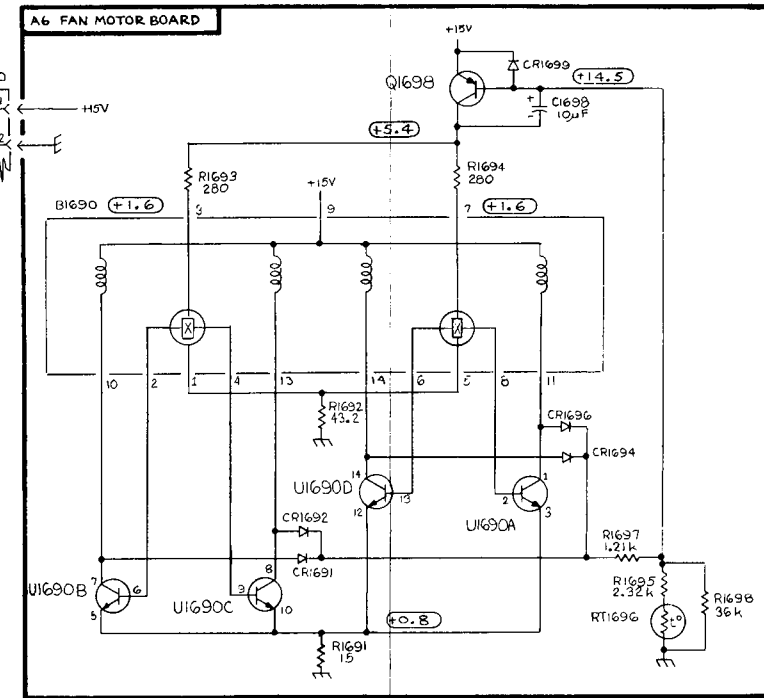
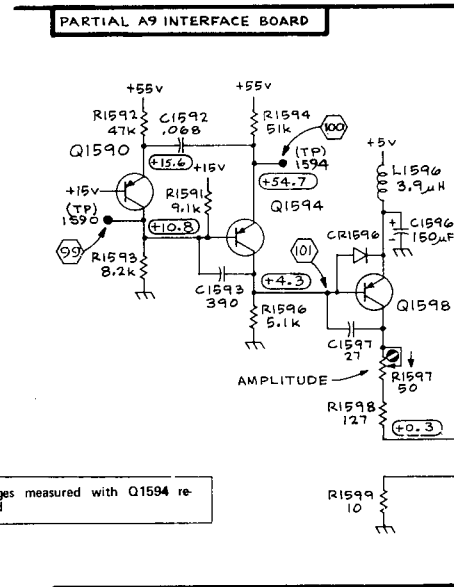

SEE PARTS LIST FOR SEMICONDUCTOR TYPES.

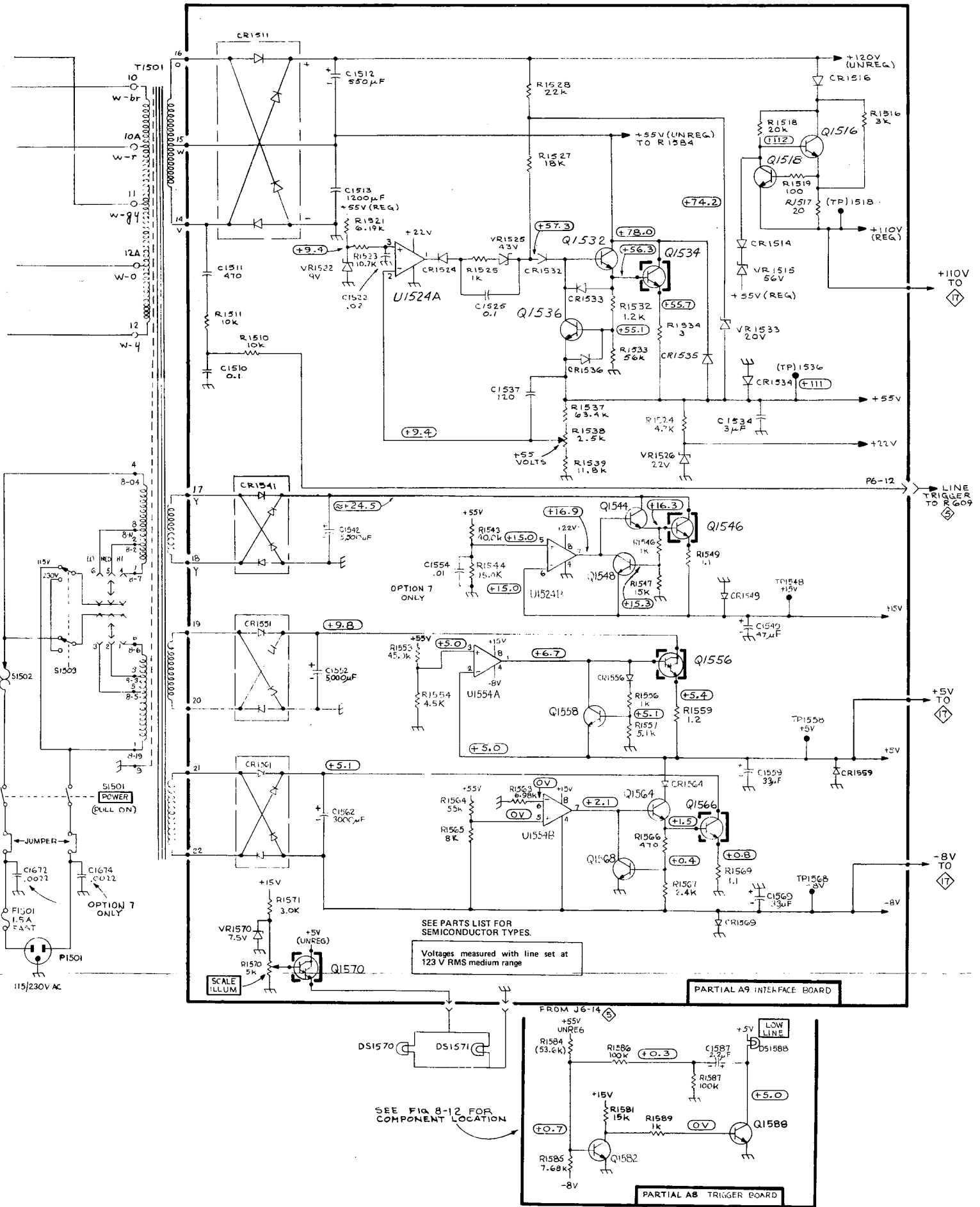

465 MOD UC

@

POWER SUPPLY

1

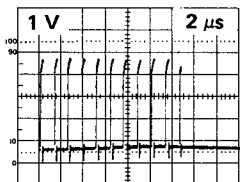

Record mode.
Adjust A TRIG
HOLDOFF for stable
display

2

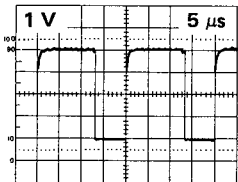

Record mode.

3

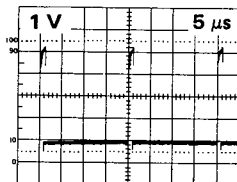

Record mode.

4

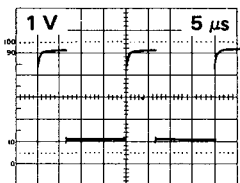

Record mode.

5

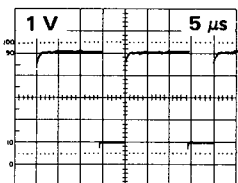

Record mode.

6

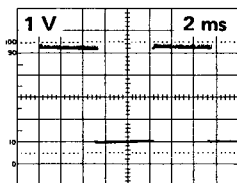

Display mode.
OVERLAY FUNCTION

7

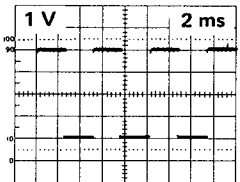

8

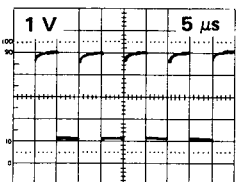

9

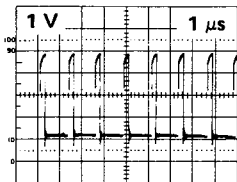

WAVEFORM CONDITIONS

Mod UC

FUNCTION

TIME/DIV X10
LINE 1 or DOT 1
LINE 2 or DOT 2

Determined by waveform
to be observed
Button out (normal)
Determined by waveform
to be observed

465 OSCILLOSCOPE (TO WHICH MOD UC IS ATTACHED)

VERT MODE
VOLTS/DIV VAR
AC-GND-DC switch
Trigger SOURCE
TRIG MODE
HORIZ DISPLAY

CH 2
Calibrated detent
GND
CH 2
SINGL SWP
A

465 OSCILLOSCOPE (TO WHICH MOD UC IS ATTACHED) (cont)

A and B TIME/DIV
STORED DISPLAY IN

Locked together at 1 ms
Button fully in

Test Oscilloscope

Trig Mode
Trigger Source
Vert Mode
Input Ch Volts/Div

Norm
Input channel
Input channel
Determined by waveform
to be observed
AC
+
NORM until required

Trigger COUPLING
A TRIGGER SLOPE
A TRIG HOLDOFF

VOLTAGE CONDITIONS

STORED DISPLAY IN

Button fully in

SINGL SWP

Triggered

RECOMMENDED TEST EQUIPMENT

Tektronix 465 Oscilloscope with 10X probe for waveforms. Tektronix Digital multimeter such as a DM44, DM501, or DM502.

Procedure to hold the 465 Mod UC in a record mode (store).

1. Select CH 2 VERT MODE on 465 Mod UC.
2. Set the AC-GND-DC switch GND.

3. Set the Trigger SOURCE to CH 2.
4. Press the SINGL SWP button. (Sweep will remain in READY condition).
5. Check during each observation that sweep remains untriggered.

Procedure to obtain display mode.

1. Set the Trigger SOURCE to LINE.

VOLTAGE & WAVEFORM CONDITIONS

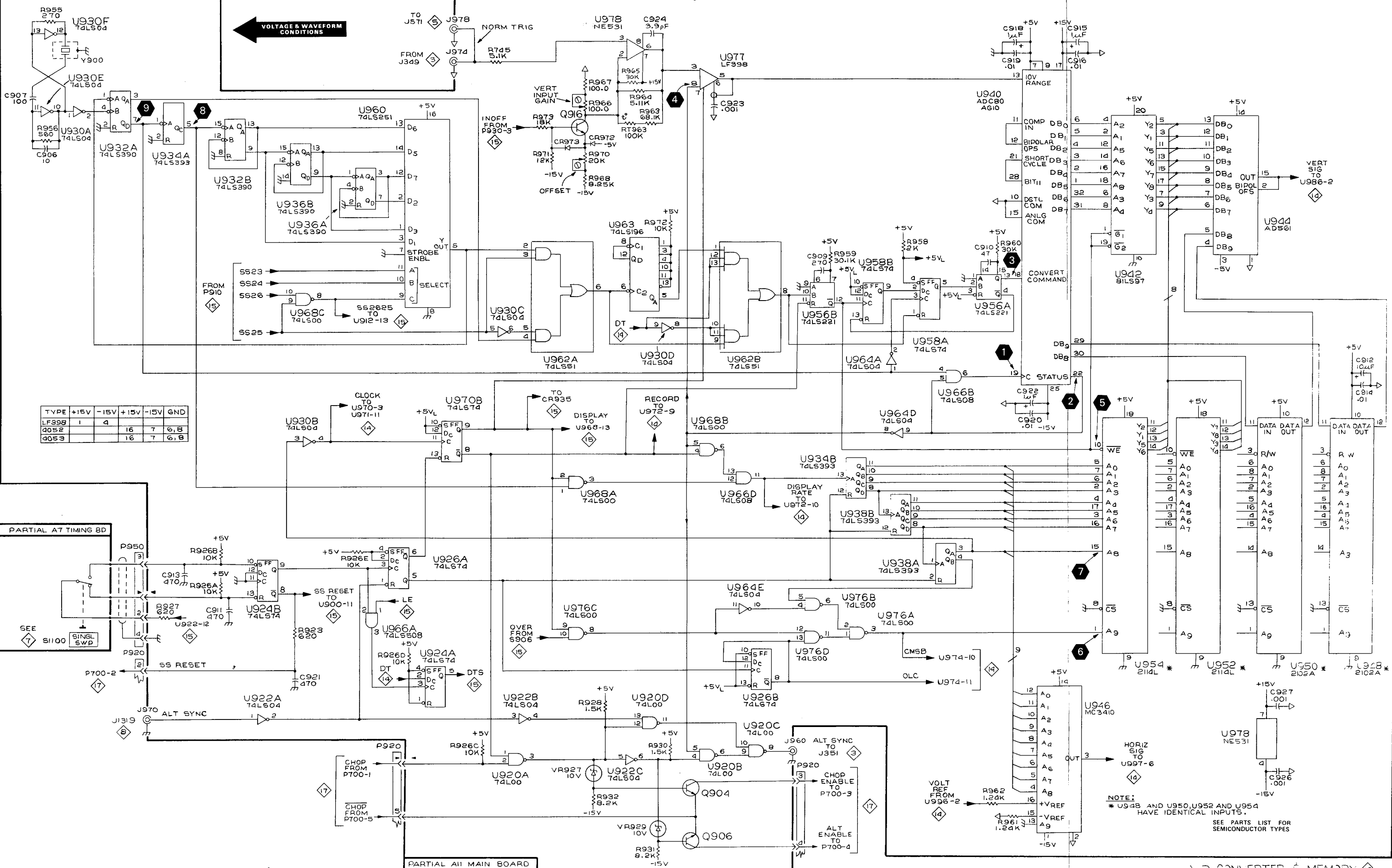

TYPE	+15V	-15V	+15V	-15V	GND
LF398	1	4	16	7	6, 8
4052			16	7	6, 8
4053			16	7	6, 8

PARTIAL A7 TIMING BD

PARTIAL A11 MAIN BOARD

NOTE:
* U948 AND U950, U952 AND U954
HAVE IDENTICAL INPUTS.
SEE PARTS LIST FOR
SEMICONDUCTOR TYPES

A-D CONVERTER & MEMORY

10

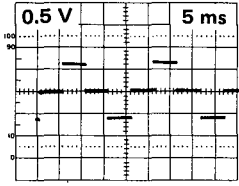

Display mode.
VOLTS FUNCTION
Six vertical divi-
sions between
lines. Zero-volts
stored.

11

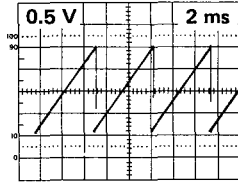

Display mode.
Slope -

12

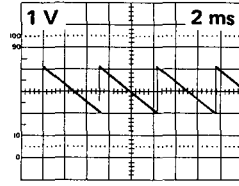

Display mode.

13

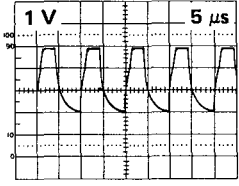

Display mode.
VOLTS FUNCTION

14

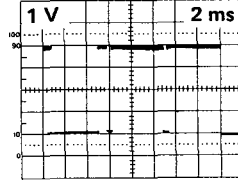

Display mode
TIME FUNCTION
Eight horizontal
divisions between
dots.

15

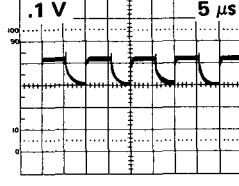

Display mode.

16

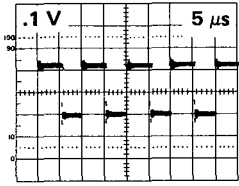

Display mode.

DATA IN

9
10

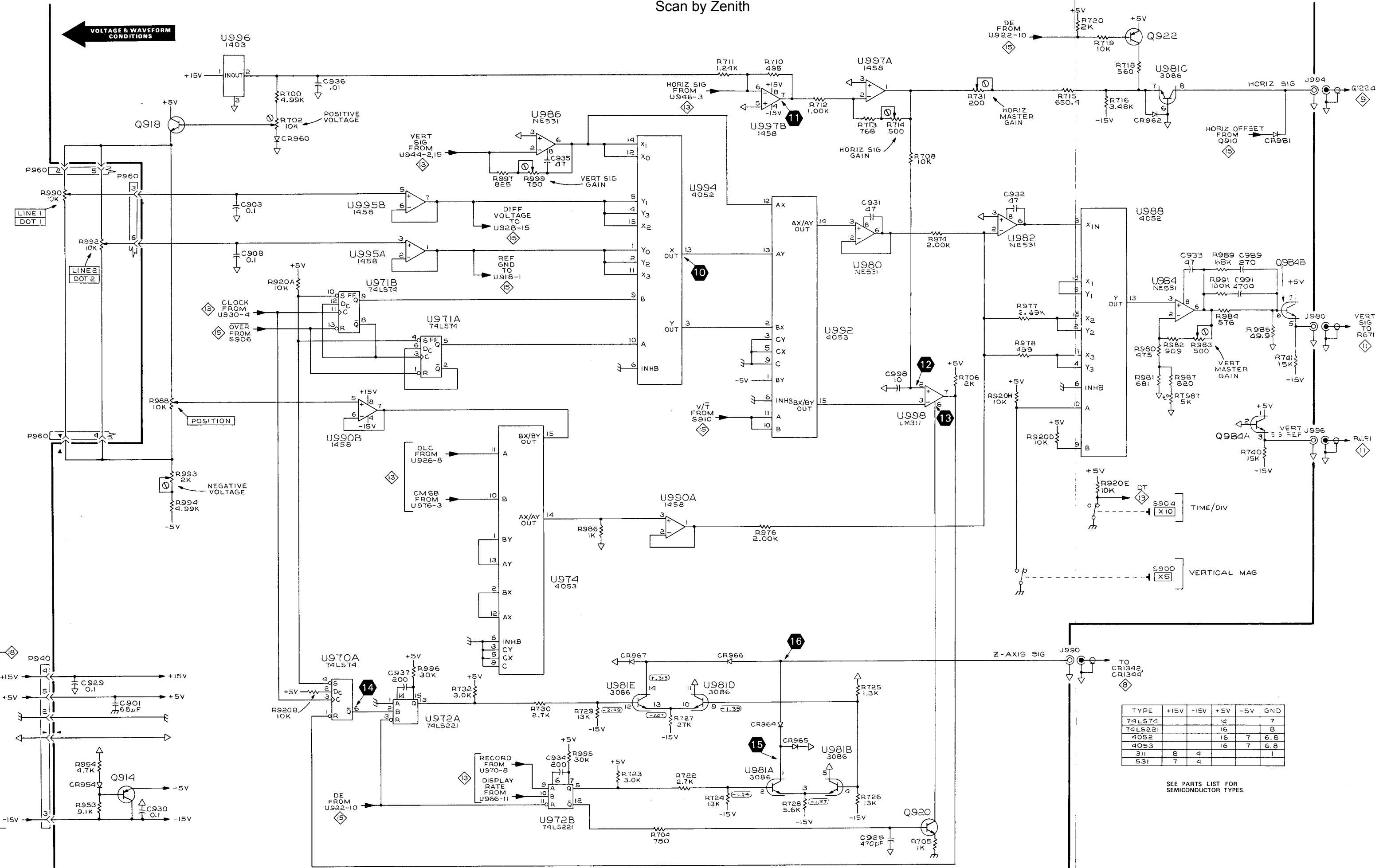

VOLTAGE & WAVEFORM CONDITIONS

LINE 1 DOT 1

LINE 2 DOT 2

POSITION

NEGATIVE VOLTAGE

+15V

+5V

-5V

-15V

PARTIAL A11 MAIN BOARD

TYPE	+15V	-15V	+5V	-5V	GND
74LS74			14	7	
74LS221			16	7	8
4052			16	7	6.8
4053			16	7	6.8
311	8	4			1
531	7	4			

SEE PARTS LIST FOR SEMICONDUCTOR TYPES.

VERTICAL, HORIZONTAL & CURSORS

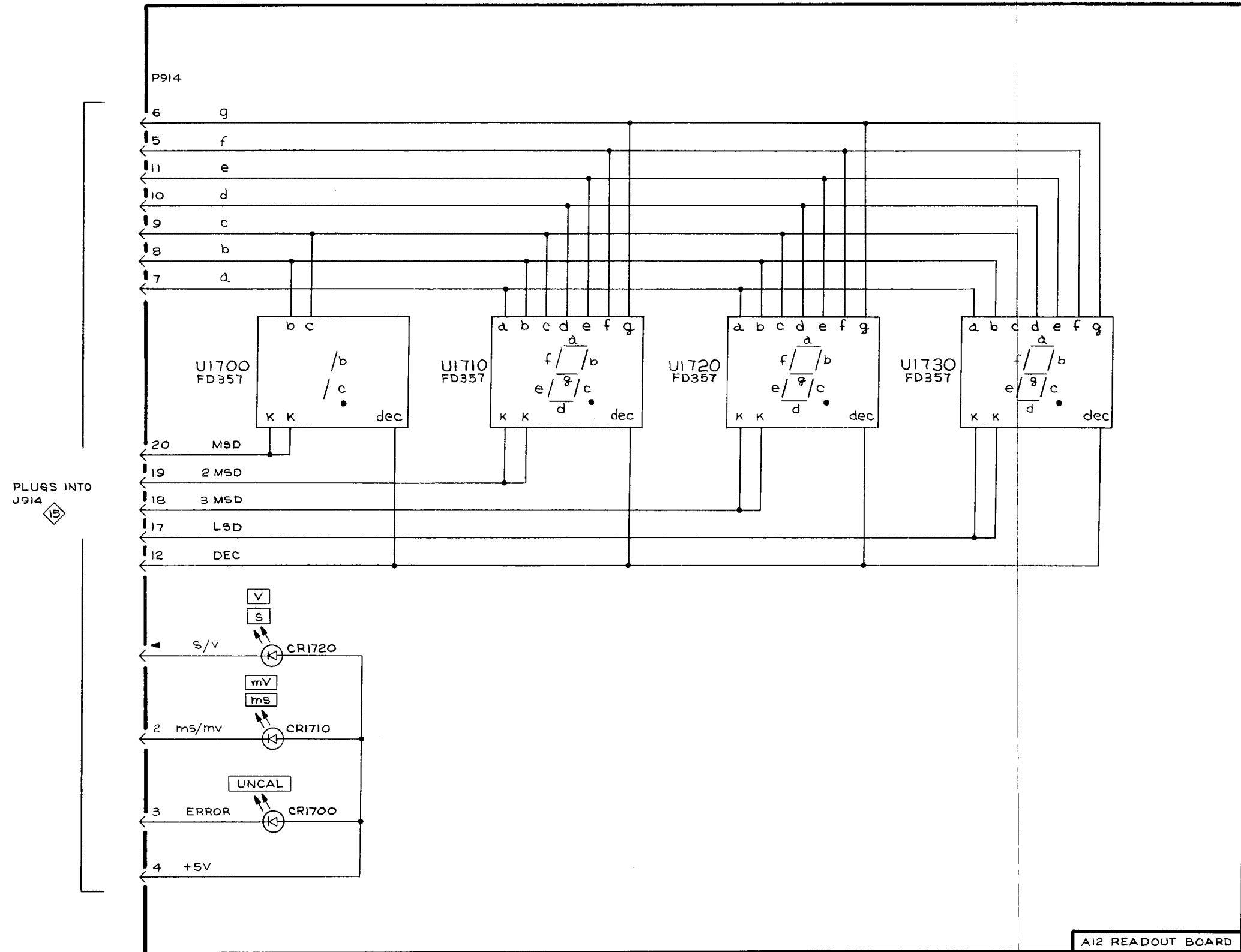

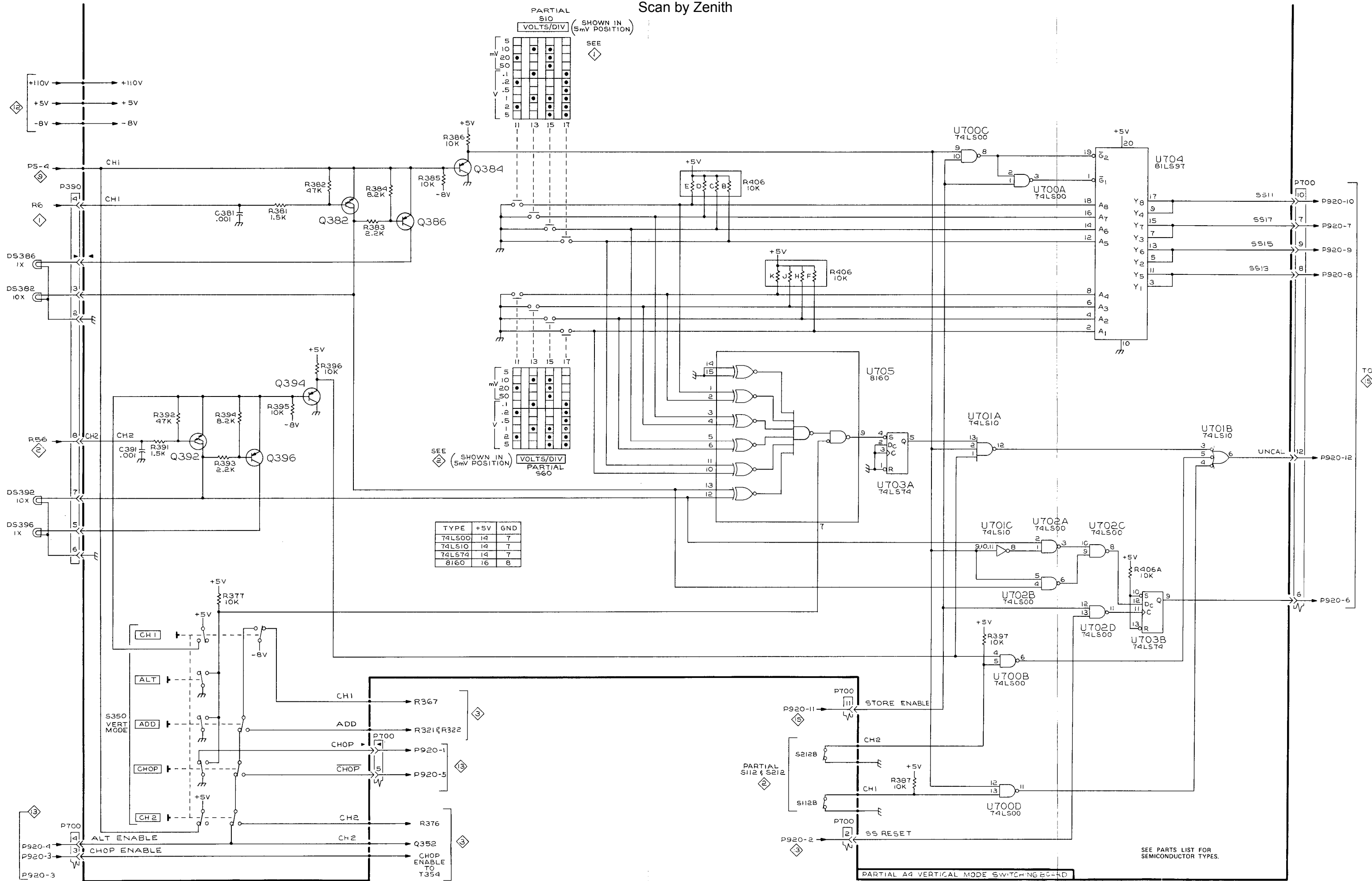

465 DIGITAL STORAGE (MOD UC)

VERTICAL MODE SWITCHING

SEE PARTS LIST FOR SEMICONDUCTOR TYPES.

PARTIAL A4 VERTICAL MODE SWITCHING BOARD

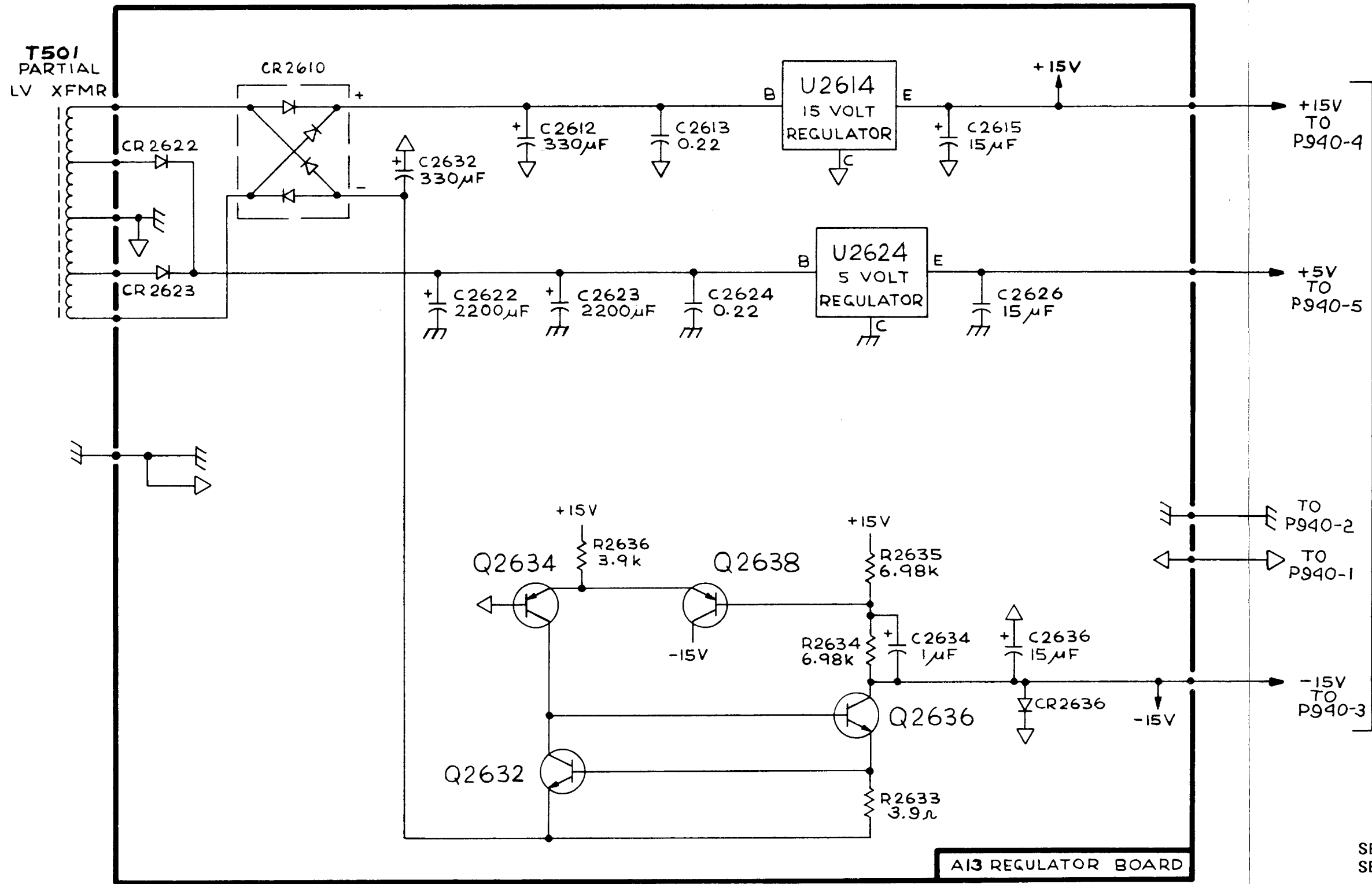

14

SEE PARTS LIST FOR SEMICONDUCTOR TYPES.

465 MOD UC

@

POWER SUPPLY 18 FOR MOD UC

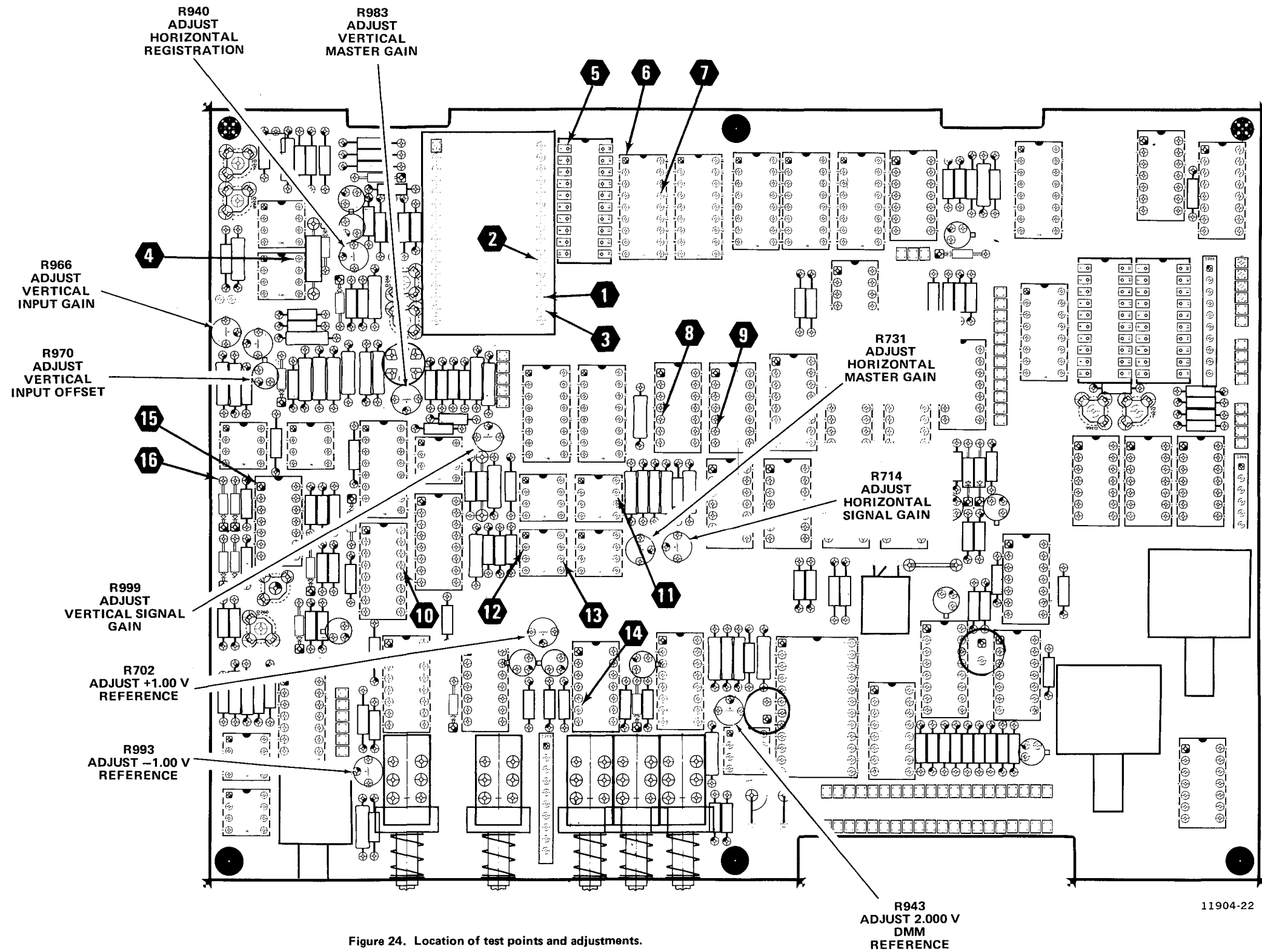

Figure 24. Location of test points and adjustments.



MANUAL CHANGE INFORMATION

PRODUCT 465 MOD UC

CHANGE REFERENCE C1

DATE 1/25/79

CHANGE:	DESCRIPTION
---------	-------------

- Page 22
Table 5 Change Access Point for +5 V to read: P940 pin 5
- Page 28
Figure 17 Reverse cable connections at 17 P920 TO P700
- Page 34
Step 3B Change Malfunction Indication to read: Trace cannot be centered vertically with U944 removed from its socket.
- Page 42
U904 Change Tektronix Part No. to read: 037-3028-00
- Sweep & Z Axis
Logic 8 diagram
U870 Change connection from P930-2 to pin 13 of U870

Vertical Mode
Switching 17
diagram
P700

Change to read:

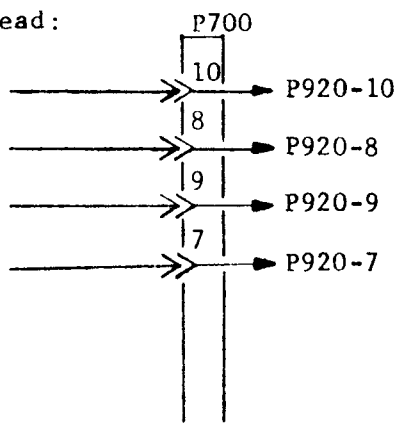

- Figure 24 Adjust-
ment locations
- Change R702 to read: ADJUST +1.03 V REFERENCE
 - Change R993 to read: ADJUST -1.03 V REFERENCE
 - Change R943 to read: ADJUST 1.996 V DMM REFERENCE