

WARNING

THE FOLLOWING SERVICING INSTRUCTIONS ARE FOR USE BY QUALIFIED PERSONNEL ONLY. TO AVOID PERSONAL INJURY, DO NOT PERFORM ANY SERVICING OTHER THAN THAT CONTAINED IN OPERATING INSTRUCTIONS UNLESS YOU ARE QUALIFIED TO DO SO.

TEKTRONIX®

465
OSCILLOSCOPE
WITH OPTIONS
(SN B250000 & UP)
SERVICE

INSTRUCTION MANUAL

Tektronix, Inc.
P.O. Box 500
Beaverton, Oregon 97077

Serial Number _____



WARRANTY

This Tektronix instrument is warranted against defective materials and workmanship for one year. Any questions with respect to the warranty should be taken up with your Tektronix Field Engineer or representative.

All requests for repairs and replacement parts should be directed to the Tektronix Field Office or representative in your area. This will assure you the fastest possible service. Please include the instrument type number or part number and serial number with all requests for parts or service.

Copyright © 1974, 1977, by Tektronix, Inc. All rights reserved. Contents of this publication may not be reproduced in any form without the permission of Tektronix, Inc.

Products of Tektronix, Inc. and its subsidiaries are covered by U.S. and foreign patents and/or pending patents.

TEKTRONIX, TEK, SCOPE-MOBILE, TELEQUIPMENT, and  are registered trademarks of Tektronix, Inc. Printed in U.S.A. Specification and price change privileges are reserved.

TABLE OF CONTENTS

	Page
LIST OF TABLES	iv
LIST OF ILLUSTRATIONS	v
SECTION 1 SPECIFICATIONS	
Introduction	1-1
VERTICAL DEFLECTION	1-1
TRIGGERING	1-1
HORIZONTAL DEFLECTION SYSTEM	1-2
X-Y OPERATION	1-2
CALIBRATOR	1-3
Z-AXIS INPUT	1-3
SIGNAL OUTPUTS	1-3
POWER SOURCE	1-3
CATHODE RAY TUBE (CRT)	1-3
SUPPLEMENTAL INFORMATION	1-3
Vertical Deflection System	1-3
Triggering	1-4
Horizontal Deflection System	1-4
Calibrator	1-4
External Z-Axis Input	1-4
Output Resistances	1-4
Cathode Ray Tube (CRT)	1-4
SECTION 2 OPERATING INFORMATION	
Introduction	2-1
Operating Voltage	2-1
CONTROLS AND CONNECTORS	2-2
Introduction	2-2
Cathode Ray Tube (CRT) and Display	2-2
Vertical Deflection System Channel 1 and Channel 2	2-2
A and B Triggering	2-4
A and B Sweep	2-5
Calibrator and Power	2-6
Rear Panel	2-6
OBTAINING BASIC DISPLAYS	2-6
Introduction	2-6
Normal Sweep Display	2-6
Magnified Sweep Display	2-7
Delayed Sweep Display	2-7
Mixed Sweep Display	2-7
X-Y Display	2-7
SECTION 3 CIRCUIT DESCRIPTION	
Introduction	3-1
Digital Logic	3-1
BLOCK DIAGRAM	3-1
CHANNEL 1 PREAMP	3-3
Introduction	3-3
Scale Factor Switching	3-4
Input Coupling	3-4
Input Attenuator	3-4
Source Follower	3-4
First Cascode Amplifier	3-5
Second Cascode Amplifier	3-5
Third Cascode Amplifier	3-5

TABLE OF CONTENTS (cont)

SECTION 3	CIRCUIT DESCRIPTION (cont)	Page
	CHANNEL 2 PREAMP	3-5
	Introduction	3-5
	Second Cascode Amplifier	3-5
	Third Cascode Amplifier	3-6
	VERTICAL SWITCHING CIRCUIT	3-6
	Introduction	3-6
	Diode Gates	3-6
	Switching Multivibrator	3-7
	Delay Line Driver	3-9
	Reference Feedback Amplifier	3-9
	Normal Trigger Pickoff	3-9
	VERTICAL OUTPUT AMPLIFIER	3-9
	Introduction	3-9
	Delay Line	3-9
	Vertical Output Amplifier—Discrete Version	3-9
	Vertical Output Amplifier—IC Version	3-10
	A AND B TRIGGER GENERATORS	3-10
	Introduction	3-10
	Trigger Source	3-10
	Trigger Coupling	3-10
	Input Source Follower	3-10
	Paraphase Amplifier	3-10
	Tunnel Diode Driver	3-11
	A AND B SWEEP GENERATOR	3-11
	Introduction	3-11
	Disconnect Amplifier	3-12
	Output Buffer Amplifier	3-12
	Sweep Start Amplifier	3-12
	Logic Multivibrator	3-12
	B Sweep Differences	3-12
	SWEEP AND Z-AXIS LOGIC CIRCUIT	3-13
	Introduction	3-13
	A Sweep Gate	3-13
	B Sweep Gate	3-13
	Sweep Control Integrated Circuit	3-13
	Holdoff Timing	3-14
	A Sweep Holdoff Amplifier	3-14
	B Sweep Holdoff Amplifier	3-14
	B Sweep Latch	3-14
	A Sweep Z-Axis Gate	3-14
	B Sweep Z-Axis	3-15
	A +Gate and B +Gate Emitter Followers	3-15
	HORIZONTAL AMPLIFIER	3-15
	Introduction	3-15
	X-Axis Amplifier	3-15
	Input Paraphase Amplifier	3-16
	Gain Setting Amplifier	3-16
	Output Amplifier	3-16
	CRT CIRCUIT	3-17
	Introduction	3-17
	High Voltage Oscillator	3-17
	High Voltage Regulator	3-18
	High Voltage Rectifier and Output	3-18
	CRT Control Circuits	3-18
	Z-Axis Amplifier	3-18
	DC Restorer Circuit	3-19

TABLE OF CONTENTS (cont)

SECTION 3	CIRCUIT DESCRIPTION (cont)	Page
	CALIBRATOR	3-19
	Introduction	3-19
	Multivibrator	3-19
	Output Amplifier	3-19
	A TRIGGER VIEW AMPLIFIER	3-20
	Introduction	3-20
	Amplifier	3-20
	LOW VOLTAGE POWER SUPPLY	3-20
	Introduction	3-20
	Power Input	3-20
	Secondary Circuit	3-20
	FAN MOTOR CIRCUIT	3-22
SECTION 4	MAINTENANCE	
	Introduction	4-1
	CABINET AND RACK ADAPTER REMOVAL	4-1
	PREVENTIVE MAINTENANCE	4-3
	Introduction	4-3
	Cleaning	4-3
	Visual Inspection	4-4
	Lubrication	4-5
	Semiconductor Checks	4-5
	Recalibration	4-5
	TROUBLESHOOTING	4-5
	Introduction	4-5
	Troubleshooting Aids	4-5
	Troubleshooting Equipment	4-7
	Troubleshooting Techniques	4-7
	CORRECTIVE MAINTENANCE	4-9
	Introduction	4-9
	Obtaining Replacement Parts	4-9
	Soldering Techniques	4-10
	Component Removal and Replacement	4-11
	Recalibration After Repair	4-16
	Instrument Repackaging	4-16
	RACKMOUNTING	4-17
SECTION 5	PERFORMANCE CHECK	
	Purpose	5-1
	Limits and Tolerances	5-1
	Line Voltage Selection	5-1
	Equipment Required	5-1
	Special Fixtures	5-1
	Test Equipment Alternatives	5-1
	Preparation	5-1
	INDEX TO PERFORMANCE CHECK	5-1
	VERTICAL	5-3
	TRIGGERS	5-7
	HORIZONTAL	5-10

TABLE OF CONTENTS (cont)

SECTION 6	CALIBRATION	Page
	Purpose	6-1
	Limits and Tolerances	6-1
	Step Titles	6-1
	Line Voltage Selection	6-1
	Internal Adjustments	6-1
	Display	6-1
	Test Equipment Required	6-1
	Interactions	6-1
	Preparation	6-1
	INDEX TO CALIBRATION PROCEDURE	6-5
	POWER SUPPLY	6-8
	DISPLAY AND Z-AXIS	6-10
	VERTICAL	6-12
	TRIGGERS	6-24
	HORIZONTAL	6-35
	GATES, CALIBRATOR AND EXT Z-AXIS	6-43
SECTION 7	ELECTRICAL PARTS LIST	7-1
	OPTIONS	TAB PAGE
SECTION 8	DIAGRAMS	
SECTION 9	MECHANICAL PARTS LIST	9-1
CHANGE INFORMATION		

LIST OF TABLES

Table		Page
2-1	REGULATING RANGES	2-1
3-1	GAIN SWITCHING AND ATTENUATION	3-4
5-1	DEFLECTION FACTOR ACCURACY	5-5
5-2	LOW FREQUENCY COMPENSATION SETUP	5-5
5-3	A AND B TIMING ACCURACY	5-10
5-4	DELAY OR DIFFERENTIAL TIME ACCURACY	5-11
6-1	ADJUSTMENT INTERACTIONS	6-2
6-2	TEST EQUIPMENT REQUIRED	6-3
6-3	LOW VOLTAGE POWER SUPPLY LIMITS	6-8
6-4	TYPICAL LOW VOLTAGE POWER SUPPLY RIPPLE ..	6-9
6-5	VERTICAL DEFLECTION FACTOR ACCURACY	6-16
6-6	A AND B TIMING ACCURACY	6-39
6-7	A AND B MAGNIFIED ACCURACY	6-39
6-8	DIFFERENTIAL TIME ACCURACY	6-40

OPTION 7, TABLE 1 POWER SETTINGS

OPTION 7, PAGE 1

LIST OF ILLUSTRATIONS

	Page
Fig 1-1	465 Oscilloscope
Fig. 2-1	Power supply regulating range selector. 2-2
Fig. 2-2	Front and rear panel controls and connectors. 2-3
Fig. 3-1	Basic block diagram of the 465. 3-2
Fig. 3-2	Detailed block diagram of the Channel 1 Preamplifier. 3-3
Fig. 3-3	Detailed block diagram of the Channel 2 Preamplifier. 3-6
Fig. 3-4	Detailed block diagram of the Vertical Switching Circuit. 3-7
Fig. 3-5	Effect of Diode Gates on signal path (simplified Vertical Switching diagram). Conditions shown for CH 1 position of Vertical Mode switch. 3-8
Fig. 3-6	Detailed block diagram of the A Sweep Generator. 3-11
Fig. 3-7	Detailed block diagram of the Horizontal Amplifier. 3-16
Fig. 3-8	Detailed block diagram of the CRT and Z-Axis circuits. 3-17
Fig. 3-9	Detailed block diagram of the Calibrator circuit. 3-19
Fig. 3-10	Detailed block diagram of the Trigger View Amplifier. 3-20
Fig. 3-11	Detailed block diagram of the Low Voltage Power Supply. 3-21
Fig. 3-12	Foldover circuit action. 3-22
Fig. 4-1	Removing the wrap around cabinet. 4-1
Fig. 4-2	Color codes. 4-6
Fig. 4-3	Slide-out track assemblies. 4-9
Fig. 4-4	Hardware to mount instrument in the rack. 4-19
Fig. 4-5	Locating mounting holes for stationary sections. 4-20
Fig. 4-6	Mounting the stationary section to front rails. 4-20
Fig. 4-7	Supporting the rear of the stationary sections. 4-21
Fig. 4-8	Rear support kit. 4-22
Fig. 4-9	Installing the support block on the instrument. 4-22
Fig. 4-10	Inserting or removing the instrument with slide-out tracks. 4-23
Fig. 4-11	Alignment adjustments for correct operation. 4-24
Fig. 4-12	Alternative method of installing the instrument. 4-24
Fig. 4-13	Dimensional drawing. 4-25
Fig. 8-1	Semiconductor lead configurations.
Fig. 8-2	A4—Vertical Mode Switch board.
Fig. 8-3	A1 & A2 Attenuators and A3—Vertical Preamp boards.
Fig. 8-4	A5a—Vertical Output Amplifier board (discrete).
Fig. 8-5	A5b—Vertical Output Amplifier board (IC).
Fig. 8-6	A8—Trigger Generator and Sweep Logic board.
Fig. 8-7	A9 Interface board.
Fig. 8-8	A7—Timing board.
Fig. 8-9	A6—Fan board.
Fig. 8-10	Partial A8—Trigger Gen and Sweep Logic board.
Fig. 8-11	Partial A9—Interface board.
Fig. 8-12	Interface board adjustment locations.
Fig. 8-13	Vert Preampl & Atten board adjustment locations.
Fig. 8-14	Vert Output Ampl adjustment locations (discrete).
Fig. 8-15	Vert Output Ampl adjustment locations (IC).
Fig. 8-16	Trigger Gen & Sweep Logic adjustment locations.
Fig. 8-17	Timing board adjustment locations.

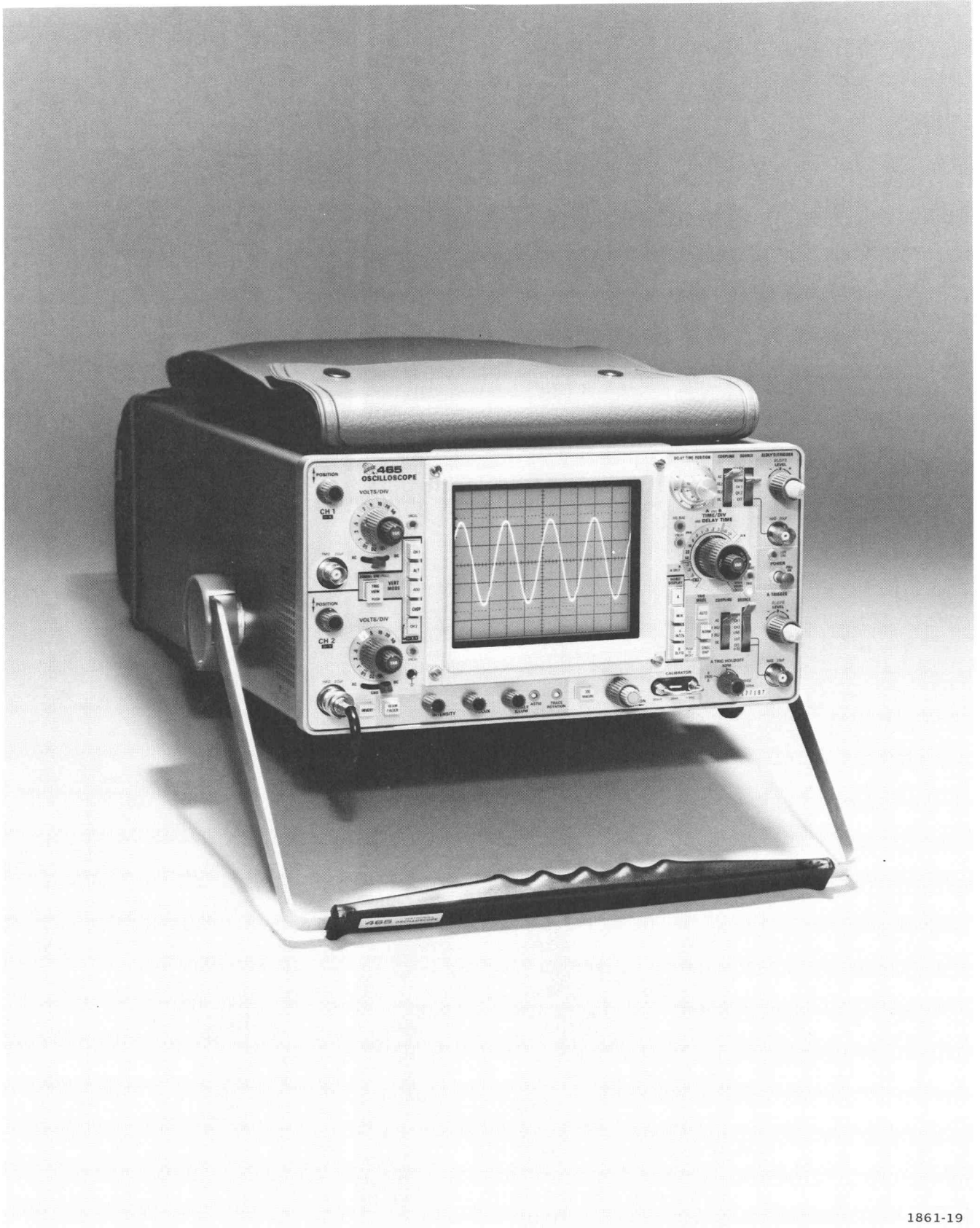

1861-19

Fig. 1-1. 465 Oscilloscope.

SPECIFICATIONS

Introduction

The 465 Oscilloscope is a wide-band, portable oscilloscope designed to operate in a wide range of environmental conditions. The instrument is light in weight and compact of design for ease of transportation, yet capable of performance necessary for accurate high-frequency measurements. The dual-channel dc-to-100 megahertz vertical deflection system provides calibrated deflection factors from 5 millivolts to 5 volts/division. The bandwidth limiting switch reduces interference from signals above about 20 megahertz for viewing low-frequency, low-level signals.

The trigger circuits provide stable sweep triggering to beyond the bandwidth of the vertical deflection system. Separate controls are provided to select the desired mode of triggering for the A and B sweeps. The A sweep can be operated in one of three modes: automatic triggering, normal triggering, or single sweep. A variable trigger holdoff control provides the ability for A sweep to trigger stably on aperiodic signals or complex digital words. The horizontal deflection system has calibrated sweep rates from 0.5 second to 0.05 microsecond/division. A X10 magnifier increases each sweep rate by a factor of 10 to provide a maximum sweep rate of 5 nanoseconds/division in the 0.05 μ s position. The delayed and mixed sweep features allow the start of the B sweep to be delayed a selected amount from the start of A sweep to provide accurate relative-time measurements. Calibrated X-Y measurements can be made with Channel 2 providing the vertical deflection and Channel 1 providing the horizontal deflection (TIME/DIV switch fully counterclockwise and VERT MODE switch to CH 2). The regulated dc power supplies ensure that instrument performance is not affected by variations in line voltage and frequency. Maximum power consumption of the instrument is approximately 75 watts.

The following instrument specifications apply over an ambient temperature range of -15°C to $+55^{\circ}\text{C}$ unless otherwise specified. Warm-up time for specified accuracies is 20 minutes. The calibration procedure given in section 6, if performed completely, will allow an instrument to meet the electrical characteristics listed below.

VERTICAL DEFLECTION SYSTEM

Deflection Factor

Calibrated range is from 5 millivolts to 5 volts/division in 10 steps in a 1-2-5 sequence. Accuracy is within 3%. Uncalibrated VAR control provides deflection factors continuously variable between the calibrated settings and extends deflection factor to at least 12.5 volts/division in the 5 VOLTS/DIV position.

Frequency Response

Bandwidth in both Channel 1 and Channel 2 is dc to at least 100 megahertz from -15°C to $+40^{\circ}\text{C}$ and dc to at least 85 megahertz from $+40^{\circ}\text{C}$ to $+55^{\circ}\text{C}$. Risetime is 3.5 nanoseconds or less from 0°C to $+40^{\circ}\text{C}$ and 4.2 nanoseconds or less from $+40^{\circ}\text{C}$ to $+55^{\circ}\text{C}$. The ac-coupled lower -3 dB point is 10 hertz or less (1 hertz or less when using a 10X probe). Vertical system bandwidth with the BW LIMIT pushbutton pulled is approximately 20 megahertz.

Chopped Mode Repetition Rate

Approximately 250 kilohertz.

Input Resistance And Capacitance

One megohm within 2% paralleled by approximately 20 picofarads.

Maximum Input Voltage

Dc coupled: 250 V (dc + peak ac) or 500 V p-p ac at 1 kHz or less.

Ac coupled: 500 V (dc + peak ac) or 500 V p-p ac at 1 kHz or less.

Cascaded Operation (CH 1 VERT SIGNAL OUT Connected to CH 2 OR Y)

Bandwidth is dc to at least 50 MHz with a sensitivity of at least 1 millivolt/division.

TRIGGERING

Sensitivity

DC Coupled: 0.3 division internal or 50 millivolts external from dc to 25 megahertz, increasing to 1.5 divisions internal or 150 millivolts external at 100 megahertz.

AC Coupled: 0.3 division internal or 50 millivolts external from 60 hertz to 25 megahertz, increasing to 1.5 divisions internal or 150 millivolts external at 100 megahertz. Attenuates all signals below about 60 hertz.

LF REJ Coupled: 0.5 division internal or 100 millivolts external from 50 kilohertz to 25 megahertz, increasing to 1.5 divisions internal or 300 millivolts external at

Specifications—465 Service (SN B250000 & up)

100 megahertz. Blocks dc and attenuates all signals below about 50 kilohertz.

HF REJ Coupled: 0.5 division internal or 100 millivolts external from 60 hertz to 50 kilohertz. Blocks dc and attenuates all signals below about 60 hertz and above about 50 kilohertz.

Trigger Jitter

0.5 nanosecond or less at 5 nanoseconds/division with 100 megahertz applied (X10 MAG on).

External Trigger Input

Maximum input voltage is 250 volts (dc + peak ac) or 250 volts peak to peak ac (1 kilohertz or less). Input resistance is 1 megohm within 10%.

Level Range

EXT: At least + and -2 volts, 4 volts peak to peak.

EXT ÷10: At least + and -20 volts, 40 volts peak to peak.

HORIZONTAL DEFLECTION SYSTEM

Calibrated Sweep Range

A Sweep: From 0.5 second/division to 0.05 microsecond/division in 22 steps in a 1-2-5 sequence. X10 MAG extends maximum sweep rate to 5 nanoseconds/division.

B Sweep: From 50 milliseconds/division to 0.05 microsecond/division in 19 steps in a 1-2-5 sequence. X10 MAG extends maximum sweep rate to 5 nanoseconds/division.

Calibrated Sweep Accuracy

Unmagnified sweep accuracy is within 2% from +20°C to +30°C (+68°F to +86°F) and within 3% from -15°C to +20°C and +30°C to +55°C (+5°F to +68°F and +86°F to +131°F). For the same temperature ranges, magnified sweep accuracy is within 3% and within 4% respectively. Exclude the first and last 50 nanoseconds of the 5 nanoseconds, 10 nanoseconds, and 20 nanoseconds magnified sweep rates. Accuracy specifications apply over full 10 divisions unless otherwise specified.

Sweep accuracy, over any 2 or less division portion of the sweep, is within 5%. Exclude the first and last magnified divisions of the 5 nanosecond and

10 nanosecond/division magnified sweep rates. Also exclude the first and last 50 nanoseconds of the 5, 10, and 20 nanoseconds/division sweep rates.

Mixed sweep accuracy is within 2% plus the measured A sweep error when viewing the A sweep portion only. The B sweep portion retains its normal accuracy. The following exclusion applies: First .5 division after display start, and first .2 division or .1 μ s (whichever is greater) after transition of A to B.

A Time/Division Variable Range

Provides continuously variable (Uncalibrated) sweep rates between the calibrated settings of the A TIME/DIV switch. Extends the slowest A sweep rate to at least 1.25 seconds/division.

A Trigger Holdoff

Increases A sweep holdoff time by at least a factor of 10.

Delay Time And Differential Time Measurement Accuracy

	+10°C to +35°C (+50°F to +95°F)	-15°C to +55°C (+5°F to +131°F)
Over 1 Or More Major Dial Division	±1%	±2.5%
Over Less Than 1 Major Dial Division	±0.01 Major Dial Division	±0.03 Major Dial Division

Delay or Differential Time Jitter

Within 0.002% (less than one part in 50,000) of the maximum available delay time when operating on power line frequencies other than 50 hertz.

Within 0.005% (less than one part in 20,000) of the maximum available delay time when operating on 50 hertz power line frequency.

Maximum available delay time is 10 times the setting of the A TIME/DIV switch.

Calibrated Delay Time (A VAR set to calibrated position)

Continuous from 5 seconds to 0.2 microsecond.

X-Y OPERATION

Sensitivity

Same as vertical deflection system.

X Axis deflection accuracy within 4%.

Variable Range

Same as vertical deflection system.

X-Axis Bandwidth

Dc to at least 4 megahertz.

Y-Axis Bandwidth

Same as vertical deflection system.

Input Resistance

Same as vertical deflection system.

Input Capacitance

Same as vertical deflection system.

Maximum Usable Input Voltage

Same as vertical deflection system.

CALIBRATOR

Output

An approximate 1 kilohertz, 30 milliampere (within 2%), 300 millivolt (within 1%), square-wave signal.

Z AXIS INPUT

Sensitivity

A 5-volt peak to peak signal causes noticeable modulation at normal intensity.

Usable Frequency Range

From dc to 50 megahertz.

SIGNAL OUTPUTS

Ch 1 Vertical

Output voltage is at least 50 millivolts/division into a 1 megohm load (at least 25 millivolts/division into a 50 ohm load).

Bandwidth is from dc to at least 50 megahertz into a 50 ohm load.

Output dc level is approximately zero volts.

A and B +Gate

Output voltage is approximately 5.5 volts, positive-going.

POWER SOURCE

Line Voltages

110, 115, 120, 220, 230, or 240 Volts ac (all within 10%), depending on the settings of the Line Voltage Selector switch and the Regulating Range Selector assembly, with a line frequency of 48 to 440 hertz. Maximum power consumption is 75 watts at 115 volts ac, 60 hertz.

CATHODE-RAY TUBE (CRT)

Graticule Area

Eight by 10 centimeters.

Phosphor

P31 is the standard phosphor with P11 offered as an option.

SUPPLEMENTAL INFORMATION

NOTE

The following supplemental information represents limits that, when met, ensure optimum instrument operation. They are, however, not instrument specifications but are intended to be used only as maintenance or operational aids.

VERTICAL DEFLECTION SYSTEM

Low—Frequency Linearity

There should be no more than 0.1 division of compression or expansion of a 2-division signal, at center screen, when the signal is positioned to the upper and lower extremes of the crt graticule area.

Bandwidth Limiter Switch

The -3 dB point should be between 15 and 25 megahertz with the 20 MHz BW switch pulled (yellow showing).

Step Response Aberrations

Aberrations on a positive going 5 division step should be +3%, -3% or less not to exceed 3% peak-to-peak on

Specifications—465 Service (SN B250000 & up)

all ranges except at 5 VOLTS/DIV. Aberrations at 5 VOLTS/DIV should be +4%, -4% or less not to exceed 4% peak-to-peak. Position effect should cause aberrations to be no more than +5%, -5% not to exceed 5% peak-to-peak.

Common-Mode Rejection Ratio (CMRR)

At least 10:1 at 20 megahertz for common mode signals of 6 divisions or less with vertical gain adjusted for best cmrr at 50 kilohertz.

Step Attenuator Balance

Adjustable to 0.2 division or less of trace shift when switching between adjacent deflection factors.

Trace Shift as Variable is Rotated

Adjustable to 1 division or less.

Invert Trace Shift

Two divisions or less when switching from normal to inverted.

Input Gate Current

0.5 nanoampere or less (0.1 division of deflection at 5 millivolts/division) from +20°C to +30°C. Four nanoamperes or less (0.8 division of deflection at 5 millivolts/division) from -15°C to +55°C.

Channel Isolation

At least 100:1 at 25 megahertz.

Position Range

Twelve divisions up and 12 divisions down from graticule center.

TRIGGERING

External Trigger Input Capacitance

Twenty picofarads within 30%.

HORIZONTAL DEFLECTION SYSTEM

A Sweep Length

10.5 to 11.5 divisions.

Magnifier Registration

There should be 0.2 division or less difference at graticule center when switching from MAG on to MAG off.

Position Range

Should be able to position the start of the sweep to the right of graticule center, and the end of the sweep to the left of graticule center.

Phase Difference Between X And Y Axes Amplifiers

Typically 3° or less from dc to 50 kilohertz.

CALIBRATOR

Repetition Rate

Repetition rate accuracy is 1 kilohertz within 25%.

Output Resistance

Approximately 9.4 ohms.

EXTERNAL Z AXIS INPUT

Voltages applied to the EXT Z AXIS INPUT connector should be limited to less than 100 volts (dc + peak ac) or 100 volts peak to peak ac at 1 kilohertz or less.

OUTPUT RESISTANCES

Output resistance of the CH 1 VERT SIG OUT connector is approximately 50 ohms.

Output resistance of A+ and B+ GATE outputs is approximately 500 ohms.

CATHODE-RAY TUBE

Resolution

Typically at least 15 lines/division horizontally and vertically.

Geometry

0.1 division or less of tilt or bowing.

Raster Distortion

0.1 division or less.

Nominal Accelerating Potential

Approximately 18,500 volts.

OPERATING INFORMATION

Introduction

This section of the manual is intended to allow the operator to become familiar with the instrument power requirements, functions of controls and connectors, and how to obtain a few basic displays. For more complete operating information, refer to the 465 Operators Handbook.

Operating Voltage

WARNING

This instrument is designed for operation from a power source with its neutral at or near earth (ground) potential with a separate safety-earth conductor. It is not intended for operation from two phases of a multi-phase system, or across the legs of a single-phase three-wire system.

This instrument can be operated from either a 115-volt or 230-volt nominal line voltage source, 48 to 440 hertz. The Line Voltage Selector switch on the right side panel converts the instrument from one nominal operating voltage to the other. The Regulating Range Selector assembly on the instrument rear panel selects one of three regulating ranges for each nominal line voltage; it also contains the line fuse for overload protection. To select the correct nominal line voltage and regulating range, proceed as follows:

1. Disconnect the instrument from the power source.

2. To convert from 115-volts nominal to 230-volts nominal line voltage, set the selector switch to the 230 volts position (toward the rear of the instrument). Change the line-cord plug to match the power source or use a 115-to-230 volt adapter. Check for correct fuse for the line voltage selected (see Table 2-1).

Power Cord Conductor Identification

Conductor	Color	Alternate Color
Ungrounded (Line)	Brown	Black
Grounded (Neutral)	Blue	White
Grounding (Earthing)	Green-Yellow	Green-Yellow

3. To change regulating ranges, loosen the 2 captive screws which hold the cover onto the Regulating Range Selector assembly, then pull to remove the cover.

4. Pull out the range selector switch bar (see Fig. 2-1). Slide the bar to the desired position and plug it back in. Select a range which is centered about the average line voltage to which the instrument is to be connected (see Table 2-1).

TABLE 2-1

REGULATING RANGES

Range Selector Switch Position	Regulating Range	
	115 V Nominal	230 V Nominal
Lo (switch bar in bottom holes)	99 to 121 V	198 to 242 V
M (switch bar in middle holes)	104 to 126 V	208 to 252 V
HI (switch bar in top holes)	108 to 132 V	216 to 264 V
Fuse Size	1.5 A 3AG Fast-blow	0.75 A 3AG Fast-blow

5. Re-install the cover and tighten the 2 captive screws.

6. Before applying power to the instrument, check that the line voltage selector switch and the indicating tab on the Regulating Range Selector assembly are in the correct position for the desired nominal line voltage and regulating range.

CAUTION

This instrument may be damaged if operated with the line voltage selector switch or the Regulating Range Selector assembly set to incorrect positions for the line voltage applied, or if the wrong line fuse is used.

Operating Information—465 Service (SN B250000 & up)



Fig. 2-1. Power supply regulating range selector.

The 465 is designed to be used with a three-wire ac power system. If a 3 to 2 wire adapter is used to connect this instrument to a 2 wire ac power system, be sure to connect the ground lead of the adapter to earth (ground). Failure to complete the ground system may allow the chassis of this instrument to be elevated above ground potential and pose a shock hazard.

The feet on the rear panel provide a convenient cord wrap to store the power cord when not in use.

CONTROLS AND CONNECTORS

Introduction

The major controls and connectors for operation of the 465 are located on the front panel of the instrument. A few auxiliary functions are provided on the rear panel. Fig. 2-2 shows the front and rear panels of the 465. A brief description of each control and connector is given here. More detailed operating information is given in the 465 Oscilloscope Operators Manual.

Cathode-Ray Tube (CRT) and Display

1. BEAM FINDER Compresses the display to within the graticule area, independently of display position or applied signals.
2. INTENSITY Controls brightness of the display.

3. FOCUS Provides adjustment for optimum display definition.
4. SCALE ILLUM Controls graticule brightness.
5. ASTIG Screwdriver adjustment used in conjunction with the FOCUS control to obtain a well-defined display. Does not require readjustment in normal use.
6. TRACE ROTATION Screwdriver adjustment to align the trace with the horizontal graticule lines.

Vertical Deflection System (Channel 1 & Channel 2)

7. POSITION Controls the vertical position of the trace. In the X-Y mode of operation, the Ch 2 control positions on the Y-axis (vertically) and the Horizontal POSITION control positions on the X-axis (horizontally).
8. CH 1 OR X Input connector for Channel 1 deflection signals or X-axis deflection in the X-Y mode of operation.
9. CH 2 OR Y Input connector for Channel 2 deflection signals or Y-axis deflection in the X-Y mode of operation.
10. VOLTS/DIV Selects vertical deflection factor in a 1-2-5 sequence (VAR control must be in the calibrated detent for the indicated deflection factor).
11. VAR Provides continuously variable uncalibrated deflection factors between the calibrated settings of the VOLTS/DIV switch.
12. UNCAL Light indicates that the VAR control is not in the calibrated position.
13. Input Coupling Selects the method of coupling signal to the input of the Vertical Amplifier.
AC: Signal is capacitively coupled to the Vertical Amplifier. Dc component of signal is blocked. Low-frequency limit (lower -3 dB point) is about 10 hertz.
GND: Input signal is removed and the input circuit is grounded. Does not ground the input signal.
DC: All components of the input signal are passed to the Vertical Amplifier.

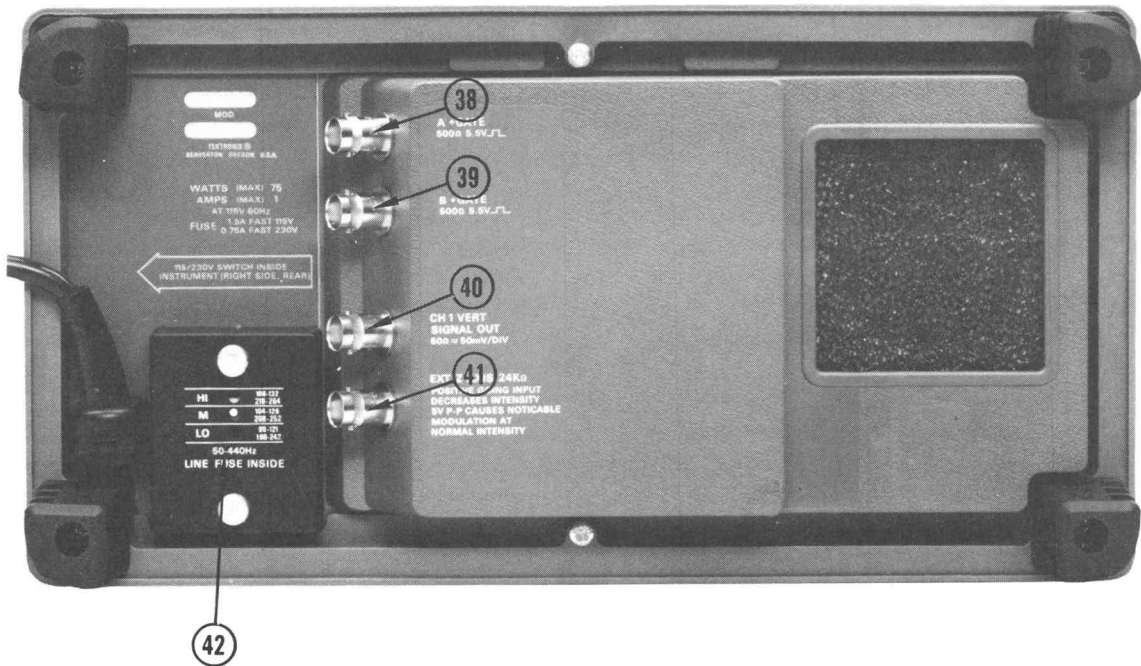
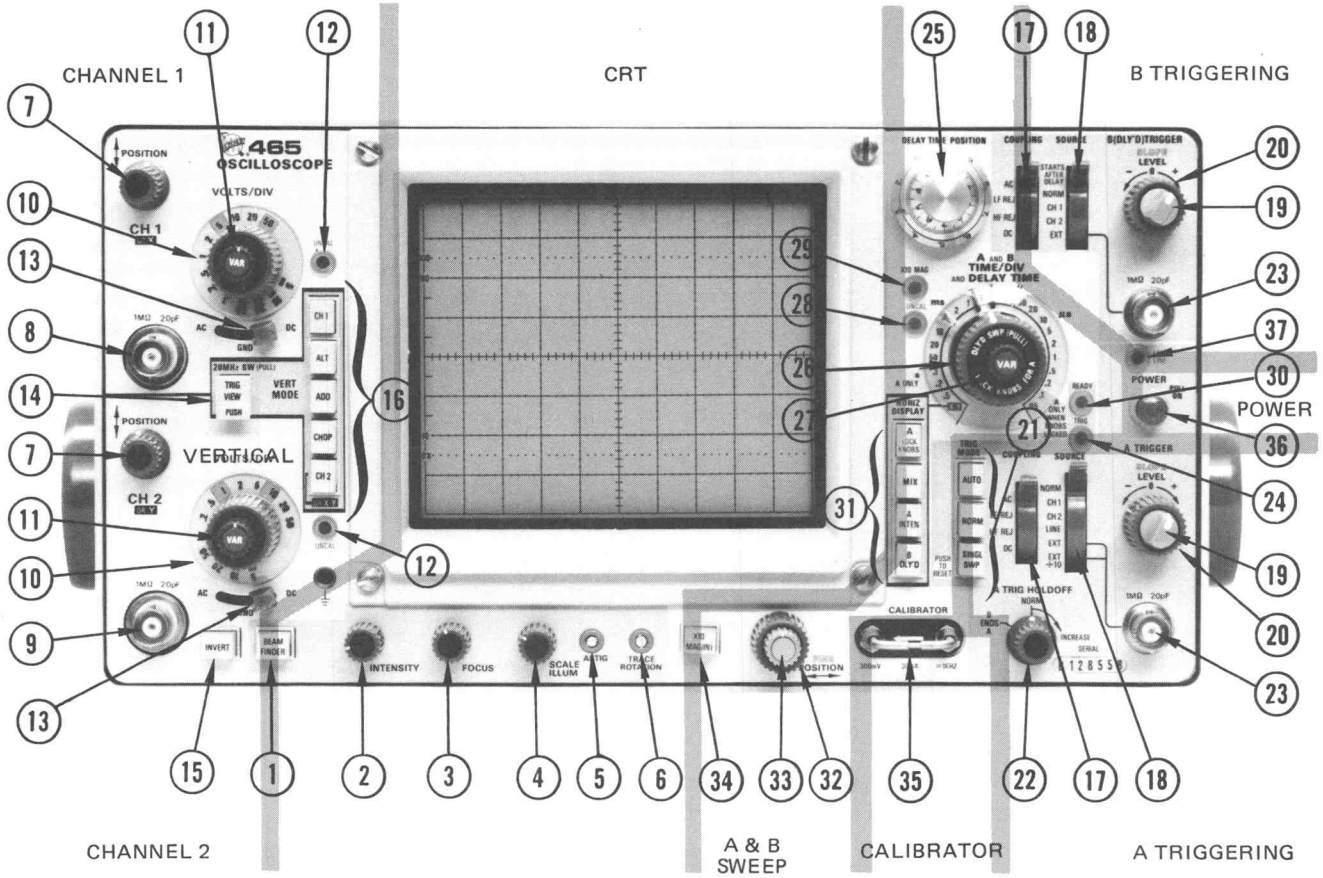

Fig. 2-2. Front and rear panel controls and connectors.

Operating Information—465 Service (SN B250000 & up)

14. 20 MHz BW/
TRIG VIEW Dual-purpose switch that, when pulled out, limits the bandwidth of the complete Vertical Deflection System to approximately 20 megahertz, or when pressed causes signal present in A Trigger Generator circuit to be displayed on the CRT.

15. INVERT Pushbutton switch that inverts the Channel 2 display.

16. VERT MODE **CH 1:** Displays Channel 1 only.

ALT: Dual-trace display of signals on both channels. Display is switched between channels at the end of each sweep.

ADD: Signals applied to the CH 1 OR X and CH 2 OR Y connectors are algebraically added and the sum is displayed on the CRT. The INVERT switch in Channel 2 allows the display to be CH 1 + CH 2 or CH 1 - CH 2.

CHOP: Dual-trace display of signals on both channels. Display is switched between channels at an approximate repetition rate of 250 kilohertz.

CH 2 OR X-Y: Displays Channel 2 only. Must be pushed when operating in X-Y mode.

A and B Triggering (both where applicable)

17. COUPLING Determines the method used to couple signal to input of trigger circuits.

AC: Rejects dc and attenuates signals below about 60 hertz. Accepts signals above about 60 hertz.

LF REJ: Rejects dc and attenuates signals below about 50 kilohertz. Accepts signals above about 50 kilohertz.

HF REJ: Accepts signals between 60 hertz and 50 kilohertz. Rejects dc and attenuates all signals outside the above range.

DC: Accepts all trigger signals from dc to 100 megahertz or greater.

18. SOURCE Selects source of trigger signal.

NORM: Internal trigger signal obtained from Vertical Deflection System. Actual source is signal(s) displayed on crt.

CH 1: A sample of the signal connected to the CH 1 OR X input connector is used as a trigger signal.

CH 2: A sample of the signal connected to the CH 2 OR Y input connector is used as a trigger signal.

EXT: Trigger signal is obtained from signal connected to the External Trigger Input connector.

EXT ÷ 10 (A trigger circuit only): External trigger signal is attenuated by a factor of 10.

STARTS AFTER DELAY (B trigger circuit only): B sweep starts immediately after the delay time selected by the DELAY-TIME POSITION dial and the DELAY-TIME switch.

LINE (A trigger circuit only): Trigger signal is obtained from a sample of the line voltage applied to the instrument.

19. SLOPE Selects the slope of the trigger signal which starts the sweep.

+: Sweep can be triggered from the positive-going portion of the trigger signal.

-: Sweep can be triggered from the negative-going portion of the trigger signal.

20. LEVEL Selects the amplitude point on the trigger signal at which the sweep is triggered.

21. A TRIG MODE Determines the operating mode for the A Trigger Circuit.

AUTO: With the proper trigger control settings, A Sweep can be initiated by signals that have repetition rates above about 20 hertz and are within the frequency range selected by the

Operating Information—465 Service (SN B250000 & up)

22. A TRIG HOLD-OFF	<p>COUPLING switch. In the absence of an adequate trigger signal or when the trigger controls are misadjusted, the sweep free-runs to produce a reference trace.</p> <p>NORM: With the proper trigger control settings, A Sweep can be initiated by signals that are within the frequency range selected by the COUPLING switch. In the absence of an adequate trigger signal or when the trigger controls are misadjusted, there is no trace.</p> <p>SINGL SWP: After a sweep is displayed, further sweeps cannot be presented until the SINGL SWP pushbutton is pressed again. The display is triggered the same as for NORM operation using the A Triggering controls.</p>	27. VAR	<p>Provides continuously variable A sweep rates between the calibrated settings of the A TIME/DIV switch. The A sweep rate is calibrated when the VAR control is fully clockwise into the calibrated detent.</p>
23. External Trigger	<p>Provides control of holdoff time between sweeps to obtain stable displays when triggering on aperiodic signals (such as complex digital words). Variable can increase holdoff time up to at least 10 times the holdoff time of the NORM position. In the B ENDS A position (fully clockwise), the A sweep is reset at the end of the B sweep to provide the fastest possible sweep repetition rate for delayed sweep presentations.</p>	28. UNCAL	<p>Light that indicates when the VAR TIME/DIV control is out of the calibrated detent and the horizontal sweep rate is uncalibrated.</p>
24. TRIG A and B Sweep	<p>Input connectors for external trigger signals.</p>	29. X10 MAG Indicator	<p>Light that indicates when the X10 MAG is turned on.</p>
25. DELAY-TIME POSITION	<p>Light that indicates A sweep is triggered.</p>	30. READY	<p>Light that indicates that A Sweep has been prepared to present a single sweep upon receipt of an adequate trigger signal.</p>
26. A AND B TIME/DIV	<p>Provides variable sweep delay between 0.20 and 10.20 times the delay time indicated by the DELAY TIME switch.</p>	31. HORIZ DISPLAY	<p>Selects the horizontal mode of operation.</p>
	<p>A TIME/DIV switch (clear plastic outer flange) selects the sweep rate of the A sweep circuit and selects the basic delay time (to be multiplied by DELAY-TIME POSITION dial setting) for delayed-sweep operation. B TIME/DIV switch (inner dark knob) selects sweep rate of the B sweep circuit for delayed sweep operation only. VAR control must be in calibrated detent for calibrated A sweep rates.</p>		<p>A: Horizontal deflection provided by A Sweep. B Sweep inoperative.</p>
			<p>MIX: The first part of the horizontal sweep is displayed at a rate set by the A TIME/DIV switch and the latter part of the sweep at a rate set by the B TIME/DIV switch. Relative amounts of the display allocated to each of the two rates are determined by the setting of the DELAY-TIME POSITION dial.</p>
		32. Horizontal	<p>A INTEN: Displayed sweep rate determined by the A TIME/DIV switch. An intensified portion appears on the display during the B sweep time. This switch position provides a check of the duration and position of the B sweep (delayed sweep) with respect to the delaying sweep (A).</p>
		33. FINE	<p>B DLYD: Sweep rate determined by the B TIME/DIV switch with the delay time determined by the setting of the DELAY TIME (A TIME/DIV) switch and the DELAY-TIME POSITION dial.</p>
		34. X10 MAG	<p>Positions the display horizontally.</p>
			<p>Provides fine horizontal positioning.</p>
			<p>Increases the displayed sweep rate by a factor of 10.</p>

Operating Information—465 Service (SN B250000 & up)

Calibrator and Power

35. CALIBRATOR A combination current loop and square-wave voltage output device. Provides a 30 milliamper square-wave current, 300 millivolt square-wave voltage signal with a repetition rate of approximately 1 kilohertz.
36. POWER Turns instrument power on and off.
37. LOW LINE Light that indicates the applied line voltage is below the lower limit of the regulating range selected by the Regulating Range Selector assembly.

Rear Panel

38. A +GATE Output connector providing a positive-going rectangular pulse coincident with the A sweep time.
39. B +GATE Output connector providing a positive-going rectangular pulse coincident with the B sweep time.
40. CH 1 VERT Output connector providing a sample of the signal applied to the CH 1 input connector.
41. EXT Z AXIS Input connector for intensity modulation of the crt display.
42. Regulating Range Selector Selects the regulating range of the internal power supplies (low, medium, high; determined by specific line voltage applied to instrument).

OBTAINING BASIC DISPLAYS

Introduction

The following instructions will allow the operator who is unfamiliar with the operation of the 465 to obtain the basic displays commonly used. Before proceeding with these instructions, preset the instrument controls as follows:

Vertical Controls

VERT MODE Switch	CH 1
VOLTS/DIV Switches	Proper position determined by amplitude of signal to be applied.

VOLTS/DIV VAR Controls	Calibrated detent
Input Coupling Switches	AC
Vertical POSITION Controls	Midrange
20 MHz BW Switch	Not limited
INVERT Switch	Button out
INTENSITY Control	Fully counterclockwise
FOCUS Control	Midrange
SCALE ILLUM Control	Midrange

Trigger Controls (both A and B if applicable)

SLOPE Switch	+
LEVEL Control	0
SOURCE Switch	NORM
COUPLING Switch	AC
TRIG MODE Switch	AUTO
A TRIG HOLDOFF Control	NORM

Horizontal Sweep Controls

TIME/DIV Switches	Locked together at 1 ms
A TIME/DIV VAR	Calibrated detent
HORIZ DISPLAY Switch	A
X10 MAG Switch	Off (button out)
POSITION Control	Midrange

Normal Sweep Display

1. Set the POWER switch to on (button out). Allow several minutes for instrument warmup.

2. Connect the external signal to the CH 1 input connector.

3. Advance the INTENSITY control until the display is visible. If the display is not visible with the INTENSITY control at midrange, press the BEAM FINDER pushbutton and adjust the CH 1 VOLTS/DIV switch until the display is reduced in size vertically. Then, center the compressed display with the vertical and horizontal POSITION controls, and release the BEAM FINDER pushbutton.

4. Set the CH 1 VOLTS/DIV switch and CH 1 POSITION control for a display which remains in the display area vertically.

5. Adjust the A Trigger LEVEL control for a stable display.

6. Set the A TIME/DIV switch and the horizontal POSITION control for a display which remains in the display area horizontally.

Magnified Sweep Display

1. Preset the instrument controls and follow steps 1 through 6 for obtaining a Normal Sweep Display.
2. Adjust the horizontal POSITION control to move the area to be magnified to within the center graticule division of the crt (0.5 division on each side of the center vertical graticule line). If necessary, change the TIME/DIV switch setting so the complete area to be magnified is within the center division.
3. Set the X10 MAG switch to the on position (button in) and adjust the horizontal POSITION and FINE controls for precise positioning of the magnified display.

Delayed Sweep Displays

1. Preset the instrument controls and follow steps 1 through 6 for obtaining a Normal Sweep Display.
2. Set the HORIZ DISPLAY switch to A INTEN and the B Trigger SOURCE switch to STARTS AFTER DELAY.
3. Pull out the B TIME/DIV switch knob and turn clockwise so the intensified zone on the display is the desired length. Adjust the INTENSITY control to achieve the desired display brightness.
4. Adjust the DELAY-TIME POSITION dial to position the intensified zone to the portion of the display to be delayed.
5. Set the HORIZ DISPLAY switch to B DLYD. The intensified zone on the display noted in step 3 is now being displayed in delay form. The delayed sweep rate is indicated by the white line on the B TIME/DIV switch knob.
6. For a delayed sweep display that will exhibit less jitter, set the B Trigger SOURCE switch to the same position as the A Trigger SOURCE switch and adjust the B Trigger LEVEL control for a stable display. If the A Trigger

SOURCE switch is in the LINE position, a sample of the line voltage will have to be supplied to the B Trigger circuit through the B EXT trigger input with the B SOURCE switch in the EXT position.

Mixed Sweep Displays

1. Preset the instrument controls and follow steps 1 through 6 for obtaining a Normal Sweep Display.
2. Pull out on the B TIME/DIV switch knob and turn clockwise to the desired sweep rate. Adjust the INTENSITY control to achieve the desired display brightness.
3. Set the HORIZ DISPLAY switch to MIX and B SOURCE to STARTS AFTER DELAY. The CRT display now contains more than one time factor on the horizontal axis. The left portion of the display is at the A Time Base sweep rate and the right part is at the B Time Base sweep rate. The start of the B Time Base portion of the display can be changed by adjusting the DELAY-TIME POSITION control.

X-Y Display

1. Preset the instrument controls and turn the instrument power on. Allow several minutes for instrument warm-up.
2. Set the TIME/DIV switch to X-Y and the VERT MODE to CH 2. Apply the vertical signal to the CH 2 or Y input connector and the horizontal signal to the CH 1 or X input connector. The CH 2 POSITION control will provide vertical positioning and the Horizontal POSITION control will provide horizontal positioning.
3. Advance the INTENSITY control until the display is visible. If the display is not visible with the INTENSITY control at midrange, press the BEAM FINDER pushbutton and adjust the CH 1 and CH 2 VOLTS/DIV switches until the display is reduced in size both vertically and horizontally. Then, center the compressed display with the CH 2 POSITION and horizontal POSITION controls, and release the BEAM FINDER pushbutton. Adjust the FOCUS control for a well-defined display.

CIRCUIT DESCRIPTION

Introduction

This section of the manual contains a description of the circuitry used in the 465 Oscilloscope. The description begins with a discussion of the instrument, using the basic block diagram shown in Fig. 3-1. Then, each circuit is described in detail using detailed block diagrams to show the interconnections between the stages in each major circuit and the relationship of the front panel controls to the individual stages.

A complete block diagram is located in the Diagrams Section at the back of this manual. This block diagram shows the overall relationship between all of the circuits. Complete schematics of each circuit are also given in the Diagrams Section. Refer to these diagrams throughout the following circuit description for electrical values and relationships.

Digital Logic

Digital logic techniques are used to perform many functions within this instrument. The function and operation of the logic circuits are described using logic symbology and terminology. All logic functions are described using the positive logic convention. Positive logic is a system of notation where the more positive of two levels (HI) is called the true or 1 state; the more negative level (LO) is called the false or 0 state. The HI-LO method of notation is used in this logic description. The specific voltages which constitute a HI or LO state vary between individual devices.

It should be noted that not all of the integrated circuit devices in this instrument are digital logic devices. The function of non-digital devices will be described individually using operating waveforms or other techniques to illustrate their function.

BLOCK DIAGRAM

The following discussion is provided to aid in understanding the overall concept of the 465 Oscilloscope before the individual circuits are discussed in detail. A basic block diagram of the 465 Oscilloscope is shown in Fig. 3-1. Only the basic interconnections between the individual blocks are shown on this diagram. Each block represents a major circuit within the instrument. The number on each block refers to the complete circuit diagram, which is located at the rear of this manual.

Signals to be displayed on the crt are applied to the CH 1 OR X and/or CH 2 OR Y connectors. The input signals are then amplified by the Preamp circuits. Each Preamp circuit includes separate vertical deflection factor, input coupling, balance, gain and variable attenuation controls. A trigger pickoff stage in each Vertical Preamp circuit supplies a sample of the channel signals to the Trigger Generator circuit. A sample of the Channel 1 signal is also supplied to the CH 1 VERT SIGNAL OUT connector on the instrument rear panel. In the X-Y mode of operation the Channel 1 signal is connected to the input of the Horizontal Amplifier circuit to provide the X-axis deflection. The Channel 2 Vertical Preamp circuit contains an invert feature to invert the Channel 2 signal as displayed on the crt. The outputs of both Vertical Preamp circuits are connected to the Vertical Switching circuit. This circuit selects the channel(s) to be displayed. An output signal from this circuit is connected to the Z-Axis Amplifier circuit to blank out the switching transients between channels when in the chopped mode of operation. A trigger pickoff stage at the output of the Vertical Switching circuit provides a sample of the displayed signal(s) to the Trigger Generator circuit.

The output of the Vertical Switching circuit is connected to the Vertical Output Amplifier through the Delay Line. The Vertical Output Amplifier circuit provides the final amplification for the signal before it is connected to

Circuit Description—465 Service (SN B250000 & up)

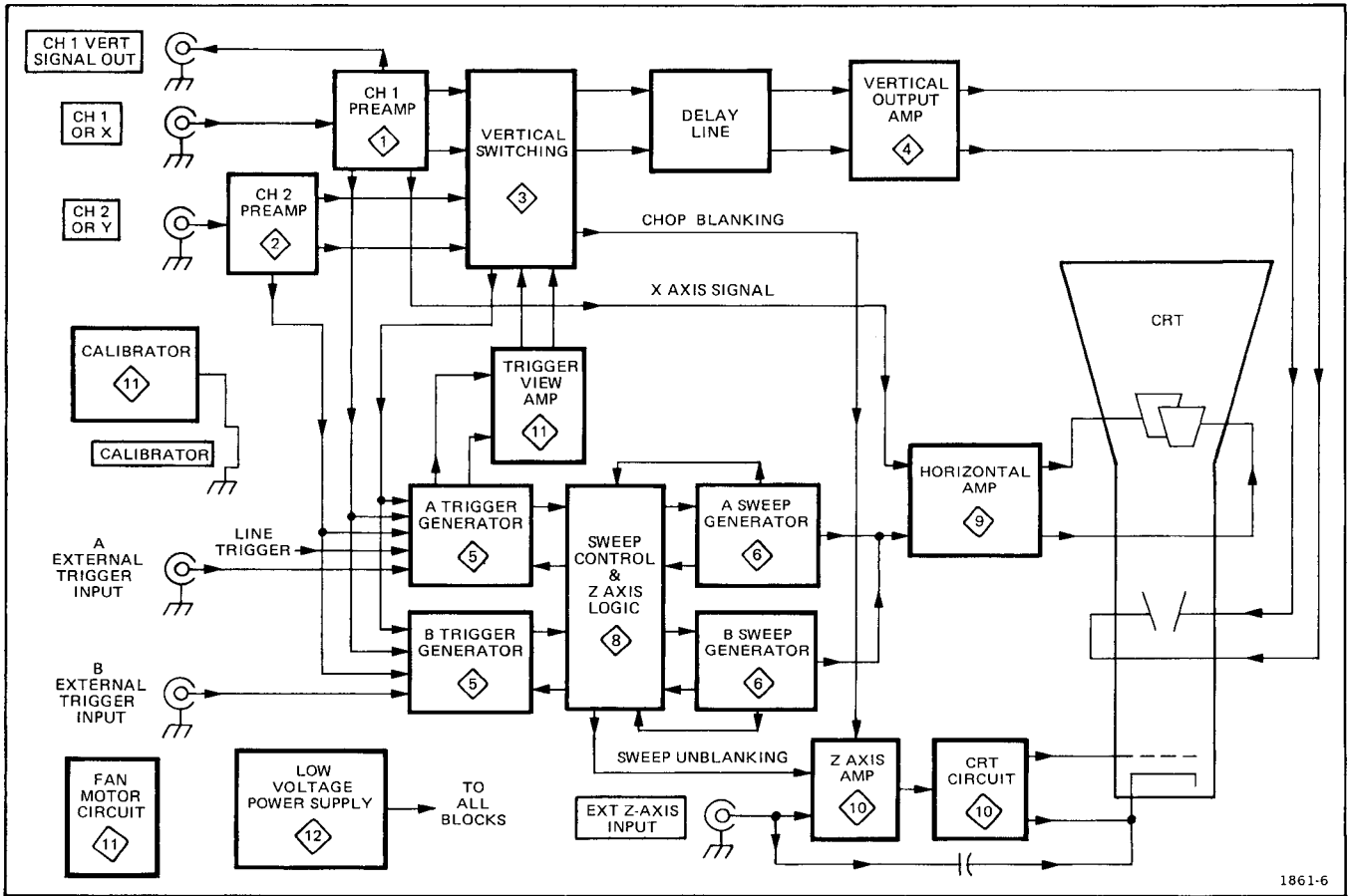

Fig. 3-1. Basic block diagram of the 465.

the vertical deflection plates of the crt. This circuit includes part of the BEAM FINDER switch. This portion, when activated, limits vertical deflection to within the viewing area as an aid in locating off-screen displays.

The A and B Trigger Generator circuits produce an output pulse which initiates the sweep signal produced by the A or B Sweep Generator circuits. The input signal to the A and B Trigger Generator circuits can be individually selected from the Channel 1 signal, Channel 2 signal, the signal(s) displayed on the crt, a signal connected to the external trigger input connectors, or a sample of the line voltage applied to the instrument. Each trigger circuit contains level, slope, coupling and source controls.

The A Sweep Generator circuit, when initiated by the A Trigger Generator circuit, produces a linear sawtooth output signal, the slope of which is controlled by the A TIME/DIV switch. The TRIG MODE switch controls the operating mode of the A Trigger Generator circuit. In the AUTO position, the absence of an adequate trigger signal,

for about 100 milliseconds after the end of holdoff, causes an A Sweep start gate to be generated. In the NORM position, a horizontal sweep is presented only when correctly triggered by an adequate trigger signal. Pushing the SINGL SWP pushbutton allows only one sweep to be initiated. The Z-Axis Logic circuit produces an unblanking gate signal to unblank the crt so that the display can be presented. This gate signal is coincident with the sawtooth produced by the A Sweep Generator circuit. A gate signal, which is also coincident with the sawtooth, is available at the A + GATE connector on the instrument rear panel. The Z-Axis Logic circuit also produces an alternate sync pulse, which is connected to the Vertical Switching circuit. This pulse switches the display between channels at the end of each sweep when the VERT MODE switch is in the ALT position.

The B Sweep Generator circuit is basically the same as the A Sweep Generator circuit. However, this circuit only produces a sawtooth output signal after a delay time determined by the A TIME/DIV switch and the DELAY TIME POSITION dial. If the B Triggering SOURCE switch is set to the STARTS AFTER DELAY position, the B Sweep

Generator begins to produce the sweep immediately following the selected delay time. If the switch is in one of the remaining positions, the B Sweep Generator circuit does not produce a sweep until it receives a trigger pulse occurring after the selected delay time.

The output of either the A or B Sweep Generator is amplified by the Horizontal Amplifier circuit to produce horizontal deflection for the crt, except in the fully counterclockwise (X-Y) position of the TIME/DIV switch. This circuit contains a 10X magnifier to increase the sweep rate 10 times in any A or B TIME/DIV switch position. Other horizontal deflection signals can be connected to the horizontal amplifier by using the X-Y mode of operation. When the TIME/DIV switch is set to X-Y, the X signal is connected to the Horizontal Amplifier circuit through the Channel 1 Vertical Preamp circuit.

The Z-Axis Amplifier circuit determines the crt intensity and blanking. The Z-Axis Amplifier circuit sums the current inputs from the INTENSITY control, Vertical Switching circuit (chopped blanking), Z-Axis Logic circuit (unblanking) and the external Z-AXIS INPUT connector. The output level of the Z-Axis Amplifier circuit controls the trace intensity through the CRT circuit. The CRT circuit provides the voltages and contains the controls necessary for operation of the cathode-ray tube.

The Power Supply circuit provides the low voltage power necessary for operation of this instrument. This voltage is distributed to all of the circuits in the instrument.

The Calibrator circuit produces a square-wave output with accurate voltage and current amplitudes which can be used to check the calibration of the instrument and the compensation of probes. The CALIBRATOR current loop provides an accurate current source for calibration of current measuring probe systems.

CHANNEL 1 PREAMP

Introduction

Input signals for vertical deflection on the crt can be connected to the CH 1 OR X input connector. In the X-Y mode of operation the input signal connected to the CH 1 OR X connector provides the horizontal (X axis) deflection (TIME/DIV switch set to X-Y, VERT MODE switch set to CH 2 OR X-Y). The Channel 1 Preamp circuit provides control of input coupling, vertical deflection factor, gain and dc balance. Fig. 3-2 shows a detailed block diagram of the Channel 1 Preamp circuit. A schematic of this circuit is shown on Diagram 1 at the rear of the manual.

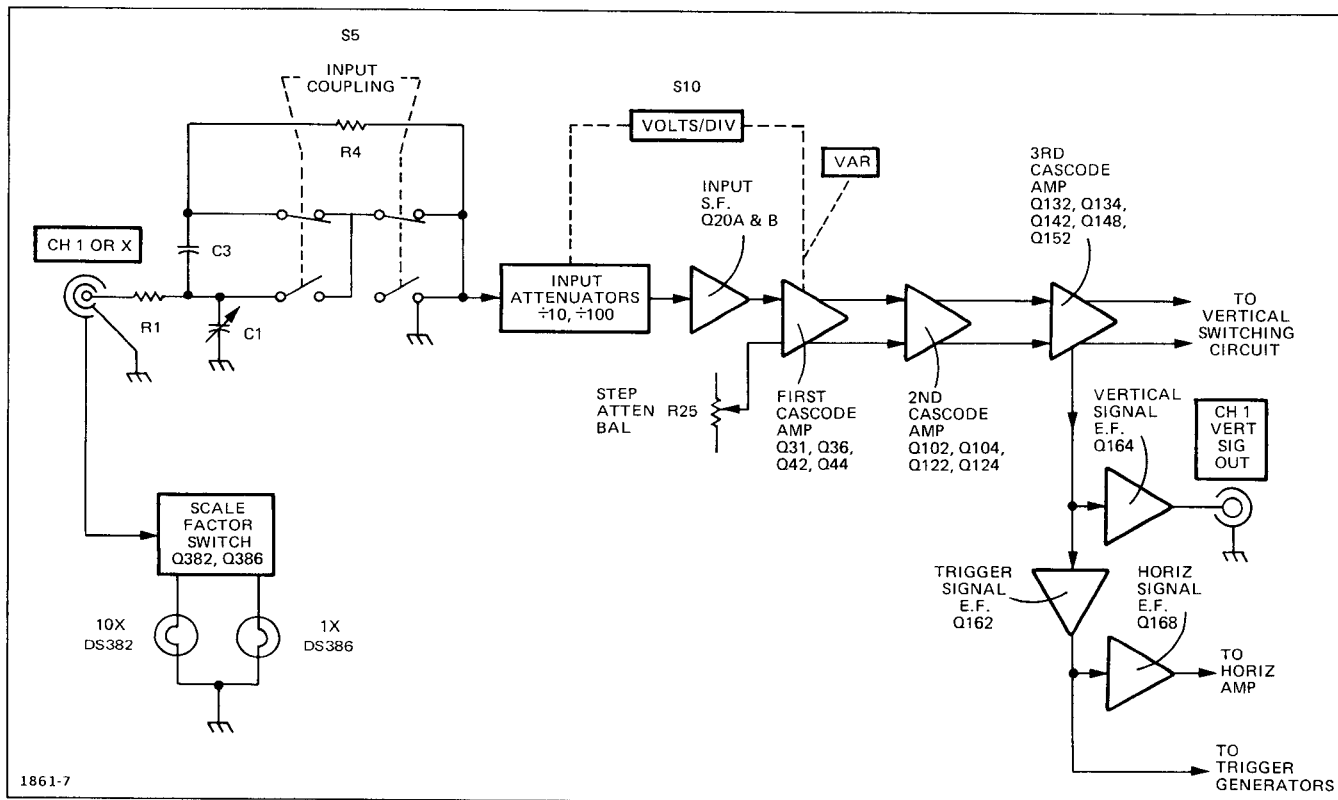

Fig. 3-2. Detailed block diagram of the Channel 1 Preampifier.

Scale-Factor Switching Circuit

The vertical deflection factor for each channel is indicated by back-lighting the appropriate figures imprinted on the flange of the VOLTS/DIV knob. When a X1 probe is connected to the CH 1 OR X input connector, the base level of transistor Q386 is determined by the voltage divider composed of R384, R383 and X10 display factor bulb DS382. Transistor Q386 is biased into saturation and conducts current through the X1 indicator DS386. When Q386 conducts, the voltage level at its collector is very close to +5 volts. Therefore, there is insufficient bias at the base of Q382 to cause Q382 to conduct, and the X10 indicator DS382 remains dark. When a X10 probe with a scale factor switching connector is attached to the CH 1 OR X input connector, the base of Q382 is returned to ground through R381. This biases Q382 into saturation and conducts current through the X10 indicator light DS382. The collector level of Q382 is very near +5 volts; therefore insufficient bias exists at the base of Q386 to cause it to conduct. Since no current flows through Q386, no current flows through DS386, and the X1 indicator remains dark.

Input Coupling

Signals applied to the input connector can be ac coupled, dc coupled, or internally disconnected from the input to the Vertical Input Amplifier circuits. When the Input Coupling switch S5 is set for dc coupling, the input signal is coupled directly to the Input Attenuator stage. When ac coupled, the input signal passes through capacitor C3. This capacitor prevents the dc component of the signal from passing to the amplifier. In the GND position, S5 opens the signal path and connects the input of the amplifier to ground. This provides a ground reference without the need to disconnect the applied signal from the input connector. Resistor R4, connected across the input coupling switch, allows C3 to be pre-charged in the GND position so that the trace remains on screen when switched to the AC position.

Input Attenuator

The effective overall deflection factor of each channel of the 465 is determined by the appropriate VOLTS/DIV switch. The basic deflection factor of the Vertical Deflection System is 5 millivolts/division of crt deflection. To achieve the deflection factor values indicated on the front panel, precision attenuators are switched into the circuit and the gain of the First Cascode Amplifier stage is changed (see Table 3-1 for when gain switching and/or attenuation occur).

For the VOLTS/DIV switch positions above 20 mV, attenuators are switched into the circuit, singly or in pairs, to help produce the vertical deflection factors indicated on the front panel. These attenuators are frequency-

TABLE 3-1

VOLTS/DIV Position	Gain Switching	X10 Attenuator	X100 Attenuator
5mV			
10mV	X		
20mV	X		
50mV		X	
.1V	X	X	
.2V	X	X	
.5V			X
1V	X		X
2V	X		X
5V		X	X

compensated voltage dividers. In addition to providing constant attenuation at all frequencies within the bandwidth of the instrument, the Input Attenuators are designed to maintain the same input characteristics (1 megohm times approximately 20 picofarads) for each setting of the VOLTS/DIV switch. Each attenuator contains an adjustable series capacitor to provide correct attenuation at high frequencies and an adjustable shunt capacitor to provide correct input capacitance.

NOTE

Each attenuator is a hybrid encapsulated plug-in assembly; therefore, replacement of individual components within the attenuator is not possible. Should defects occur, the attenuator must be replaced as a unit.

A discussion of Gain Switching appears in the section titled "First Cascode Amplifier".

Source Follower

The Channel 1 signal from the Input Attenuator is connected to the Source Follower through R16 and C16. Resistor R15 provides the input resistance for this stage. Resistor R16 limits the current drive to the gate of Q20A. Diode CR18 protects the circuit by clamping the gate of Q20A at about -8.7 volts if a high amplitude negative-going signal is applied to the CH 1 OR X input connector. Q20B is a relatively constant current source for Q20A.

First Cascode Amplifier

The paraphase amplifier composed of Q32 and Q36 converts the single-ended input signal into a push-pull output signal. C33, C34 and CR34 optimize high frequency response through the amplifier stage. R37 and R38 provide thermal balance for the amplifier. C37 and C38 minimize Miller effect through Q32 and Q36. Step Attenuator Balance adjustment R25 adjusts for no baseline shift of a crt display when switching between adjacent positions of the VOLTS/DIV switch.

The frequency response of an amplifier falls off as temperature increases due to the f_i of the transistors involved. In parallel with C33, which provides adjustable high frequency peaking, is the series combination of C34-CR34. CR34 is a varicap. RT39 controls the reverse bias and hence the capacitance of CR34. The field effect diode, CR39, supplies a constant current to RT39. With a constant current through RT39 its resistance and hence the voltage across it decreases as temperature increases. This decreases the reverse bias on CR34 which increases its capacitance. The increased capacitance of CR34 adds to the capacitance of the high frequency peaking capacitor C33. This action provides temperature sensitive peaking which partially offsets the high frequency loss due to increased ambient temperature.

The Common Base Amplifier composed of Q42 and Q44 converts the input signal currents into output voltage signals across load resistors R44 and R45. Correct vertical deflection factors are obtained by using a combination of attenuation in the Input Attenuator and changing the gain of the first Cascode Amplifier. In all VOLTS/DIV switch positions that are decade multiples of 10 millivolts/division, R46 is switched in parallel with the collector load resistors R44 and R45, which reduces the load resistance and hence the stage gain by a factor of two. C47 and R47 provide adjustable high frequency compensation. In all VOLTS/DIV switch positions that are decade multiples of 20 millivolts/division, R49 is switched in parallel with the collector load resistors R44 and R45, which reduces the load resistance and hence the stage gain by a factor of four. C48 and R48 provide adjustable high frequency compensation.

Second Cascode Amplifier

Transistors Q102-Q122 and Q104-Q124 constitute the Second Cascode Amplifier of the Channel 1 vertical preamplifier. Gain adjust R118 sets the overall gain of the Channel 1 Vertical Preamplifier by adjusting the signal current into the emitters of Q122 and Q124. The VAR control R112, when rotated out of the calibrated detent position, also adjusts the signal current into Q122 and Q124 to provide uncalibrated deflection factors between

the calibrated settings of the VOLTS/DIV switch. Variable balance adjustment R120 adjusts for no baseline shift of a crt display when rotating the VAR control. Position Centering adjustment R115 centers the range of control of the Channel 1 POSITION control.

Third Cascode Amplifier

Q132 and Q134, in conjunction with Q304 and Q308 in the Vertical Switching circuit, form the Third Cascode Amplifier. Thermistor RT131 (between the emitters of Q132 and Q134) changes in value with changes in temperature. This varies the gain of the Third Cascode Amplifier to compensate for changes in total amplifier gain that occur with variations in operating temperature. The push-pull signals picked off in the emitters of Q132 and Q134 are converted to a single-ended signal by Q142 and Q148. This signal is amplified by common-base amplifier stage Q152 and applied to the bases of emitter followers Q162 and Q164. Transistor Q164 provides the output signal to the CH 1 VERT SIGNAL OUT connector located on the rear panel. The output signal at the emitter of Q162 is used as the trigger signal source in the CH 1 positions of the Trigger SOURCE switches and as the signal source for emitter follower Q168. Transistor Q168 provides the X-axis signal from the Channel 1 Preamplifier to the Horizontal Amplifier in the X-Y mode of operation. CR164, CR165, CR166 and CR167 protect the emitter circuit of Q164 in the event large voltage levels are accidentally connected to the CH 1 VERT SIGNAL OUT connector. R155 adjusts the dc level of the CH 1 trigger source signal.

CHANNEL 2 PREAMP

Introduction

The Channel 2 Preamp circuit is basically the same as the Channel 1 Preamp. Only the specific differences between the two circuits are described here. Portions of this circuit not described in the following description operate in the same manner as for the Channel 1 Preamp. Fig. 3-3 shows a detailed block diagram of the Channel 2 Preamp circuit. A schematic of this circuit is shown on diagram 2 at the rear of this manual.

Second Cascode Amplifier

The Second Cascode Amplifier in Channel 2 is basically the same as the Second Cascode Amplifier in Channel 1 except that Channel 2 INVERT switching takes place here. For normal (non-inverted) display, +5 volts is connected to the bases of transistors Q222 and Q224 by INVERT switch S225. The voltage divider comprised of R225 and R226 applies approximately +2.5 volts to the bases of

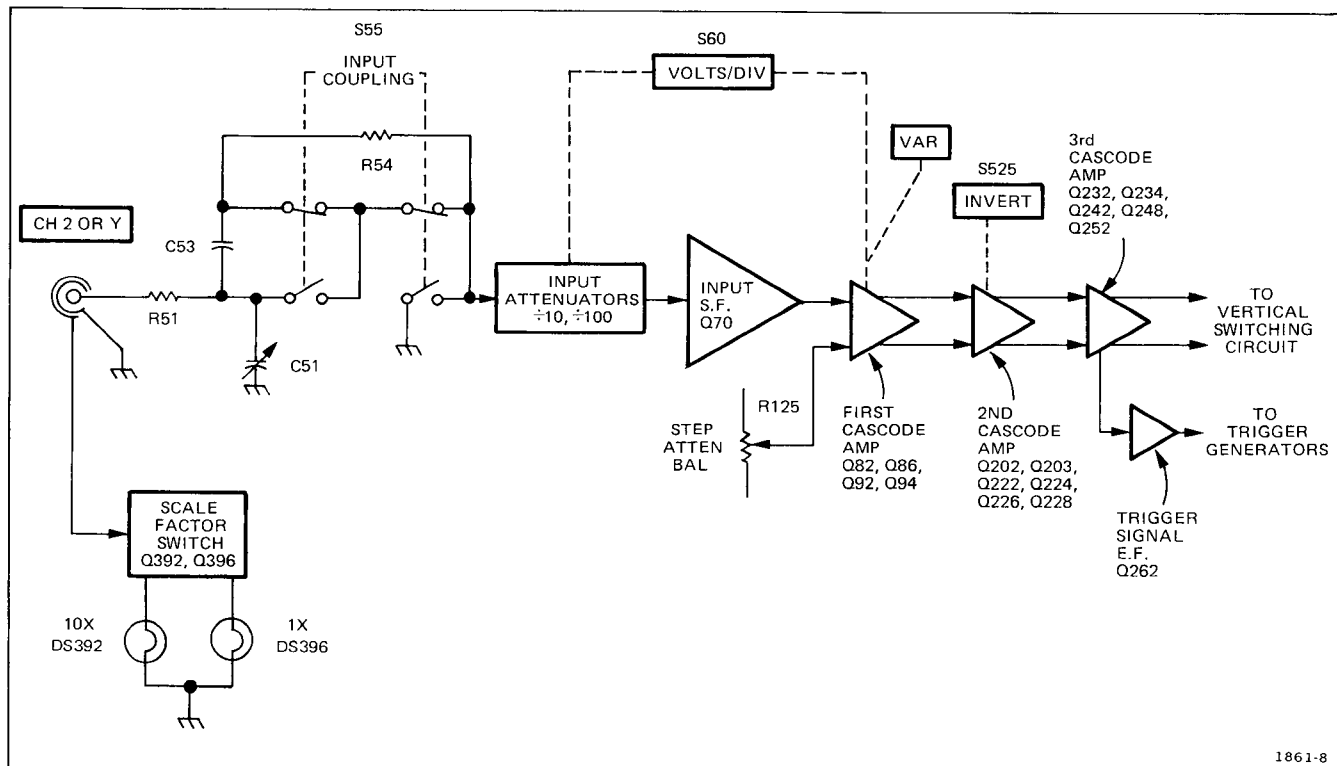

Fig. 3-3. Detailed block diagram of the Channel 2 Preamp.

Q226 and Q228. Transistors Q222 and Q224 are biased on, Q226 and Q228 are biased off, and the signal passes on to the output cascode amplifier stage. With the INVERT switch in the INVERT (button in) position, +5 volts is applied to the bases of Q226 and Q228. The voltage divider composed of R225 and R224 applies approximately +2.5 volts to the bases of Q222 and Q224. Transistors Q226 and Q228 are now biased on and Q222 and Q224 are biased off. The signal that was normally applied to the base of Q232 is now applied to the base of Q234 through transistor Q228 and the signal that was normally applied to the base of Q234 is now applied to the base of Q232 through transistor Q226.

Third Cascode Amplifier

The Trigger Pickoff circuit provides a signal to emitter follower Q262, which provides the trigger signal to the Trigger Generator circuits in the CH 2 positions of the SOURCE switches.

VERTICAL SWITCHING

Introduction

The Vertical Switching Circuit determines whether the Channel 1 and/or Channel 2 signals are connected to the Vertical Output Amplifier circuit. In the alternate and

chopped modes of operation both channels are alternately displayed on a shared time basis. Fig. 3-4 shows a detailed block diagram of the Vertical Switching circuit. A schematic of this circuit is shown on diagram 3 at the rear of this manual.

Diode Gates

The Diode Gates, consisting of four diodes each, act as switches that allow either of the Vertical Preamp output signals to be coupled to the Vertical Output Amplifier. CR304, CR305, CR307, and CR308 control the Channel 1 output and CR314, CR315, CR317 and CR318 control the Channel 2 output. These diodes are in turn controlled by the Switching Multivibrator for dual trace displays, or by the VERT MODE switch for single trace displays.

Channel 1 Display Only. When the CH 1 pushbutton is pressed, -8 volts is applied to the junction of CR315-CR317 in the Channel 2 Diode Gate through R367 (see the simplified diagram in Fig. 3-5). This forward biases CR315 and CR317 and reverse biases CR314 and CR318. Diodes CR314 and CR318 block the Channel 2 signal so it cannot pass to the Delay Line Driver. At the same time, in the Channel 1 Diode Gate, CR305 and CR307 are connected to +5 volts through R371. Diodes CR305 and CR307 are held reverse-biased while CR304 and CR308 are forward biased. Therefore, the Channel 1 signal passes to the Delay Line Driver.

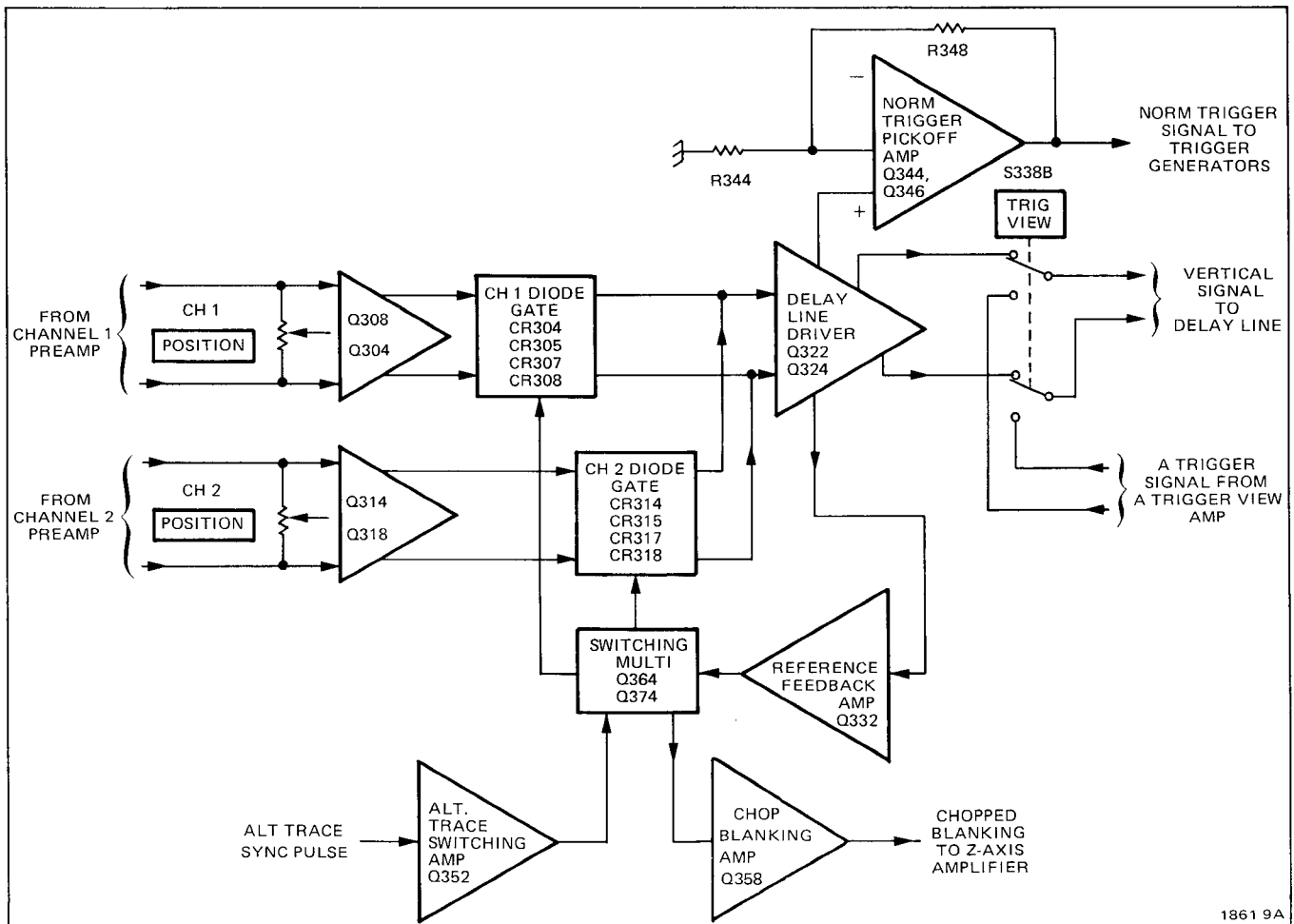

Fig. 3-4. Detailed block diagram of the Vertical Switching circuit.

Channel 2 Display Only. When the CH 2 pushbutton is pressed, the above conditions for a Channel 1 display are reversed. The junction of CR305-CR307 is connected to -8 volts through R376 and the junction of CR315-CR317 is connected to $+5$ volts through R361. The Channel 1 Diode Gate blocks the Channel 1 signal and the Channel 2 Diode Gate allows the Channel 2 signal to pass to the Delay-Line Driver.

Switching Multivibrator

Alternate Trace Display. In this mode of operation, the Switching Multivibrator operates as a bistable multivibrator. When the ALT pushbutton is pressed, -8 volts is applied to the emitter of Alternate Trace Switching Amplifier Q352 by the VERT MODE switch. Q352 is forward biased to supply current to the "on" Switching-Multivibrator transistor through R352 and CR368 or CR378. For example, if Q374 is conducting, current is supplied to Q374 through R352 and CR378. The current flow through collector resistor R371 drops the CR305-

CR307 cathode level negative so that the Channel 1 Diode Gate is blocked as for Channel 2 only operation. The signal passes through the Channel 2 Diode Gate to the Delay-Line Driver.

The alternate trace sync pulse from the A + Gate circuit is differentiated by C351 and applied to the base of Q352. At the end of A sweep the A + Gate steps negative. The resulting negative pulse momentarily turns off Q352. This turns off both Q364 and Q374. When Q352 turns on again, after the alternate trace sync pulse, the charge on C368 determines whether Q364 or Q374 conducts. For example, when Q374 was conducting, C368 was charged positive on the CR378 side to the emitter level of Q374 and negative on the CR368 side toward the negative level at the junction of CR368 and CR367. This charge is stored while Q352 is off and holds the emitter of Q364 more negative than the emitter of Q374. During the time Q364 and Q374 are turned off, the voltages at their bases become approximately equal. Now, when Q352 comes back on, the transistor with the most negative emitter conducts first,

Circuit Description—465 Service (SN B250000 & up)

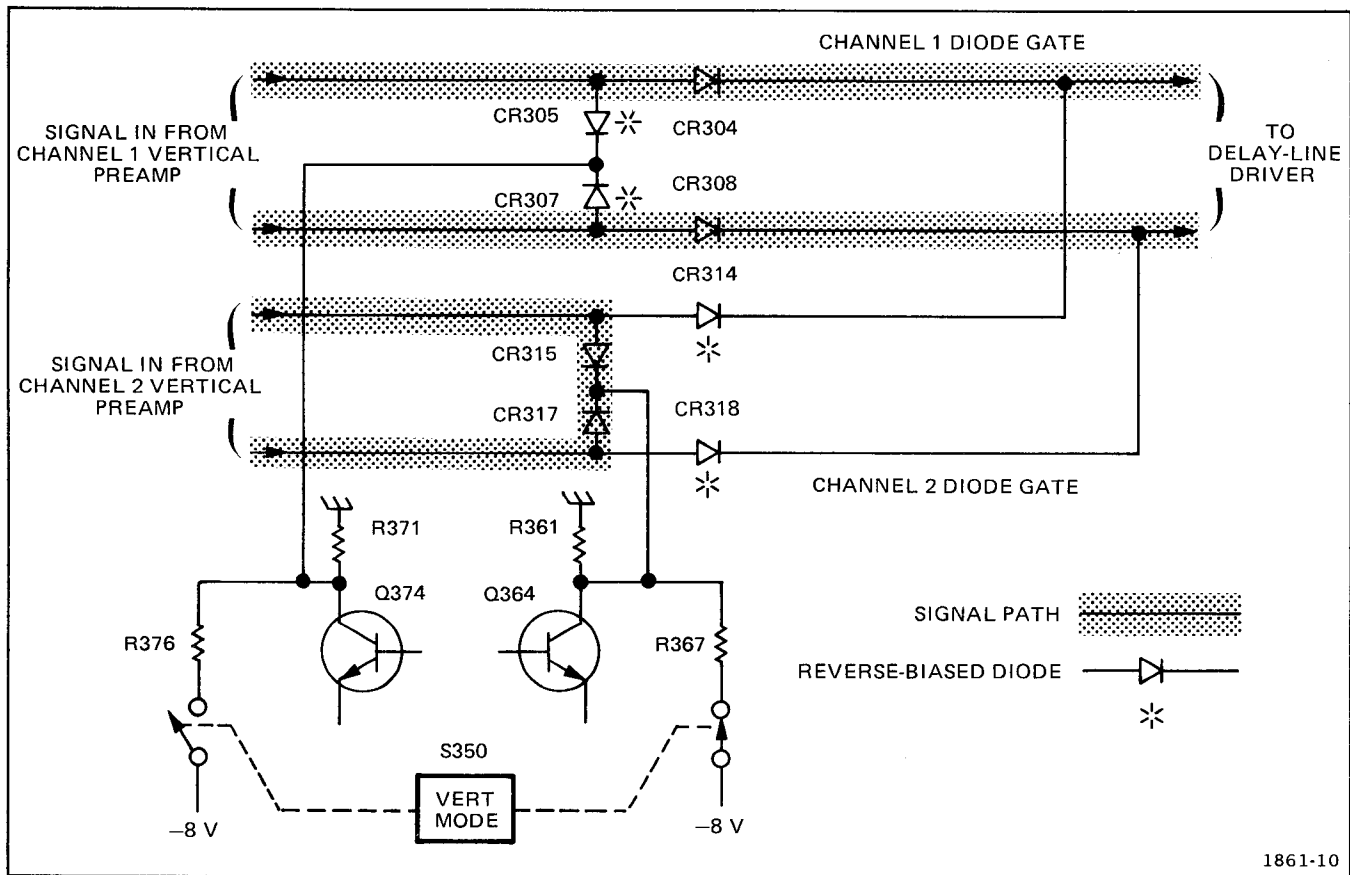

Fig. 3-5. Effect of Diode Gates on signal path (simplified Vertical Switching diagram). Conditions shown for CH 1 position of Vertical Mode switch.

and the resulting negative movement at its collector holds the other transistor off. The conditions described previously are now reversed; the Channel 2 Diode Gate is reverse-biased and the Channel 2 signal passes through the Channel 1 Diode Gate.

Chopped Mode Operation. When the CHOP pushbutton is pressed, the Switching Multivibrator free-runs at about a 250 kilohertz rate. The emitters of Q364 and Q374 are connected to -8 volts through R368, R378, and the primary of transformer T354. At the time of turn-on, one of the transistors begins to conduct; for example, Q374. The negative level at the collector of Q374 forward-biases CR305 and CR307 and back-biases CR304 and CR308 preventing the Channel 1 signal from reaching the Delay-Line Driver. Meanwhile, the Channel 2 Diode Gate passes the Channel 2 signal to the Delay-Line Driver.

The frequency-determining components in the CHOP mode are C368, R368, R370, and R378. The switching action occurs as follows: when Q374 is on, C368 attempts to charge to -8 volts through R368. The emitter

of Q364 slowly goes toward -8 volts as C368 charges. The base of Q364 is held between -8 volts and the collector level of Q374 by voltage divider R365-R374. When the emitter voltage of Q364 reaches a level slightly more negative than its base, Q364 conducts. Its collector level goes negative and pulls the base of Q374 negative through divider R364-R375 to cut Q374 off. This switches the Diode Gate to connect the opposite channel to the Delay-Line Driver. Again, C368 begins to charge towards -8 volts but this time through R378. The emitter of Q374 slowly goes negative as C368 charges until Q374 turns on. Q364 is shut off and the cycle begins again.

The Chop Blanking Amplifier Q358 provides an output pulse to the Z-Axis Amplifier circuit which blanks out the transition between the Channel 1 and the Channel 2 traces. When the Switching Multivibrator changes states, the voltage across T354 momentarily increases. A negative pulse is applied to the base of Q358 to turn it off. The width of the pulse at the base of Q358 is determined by R356 and C356. Transistor Q358 is quickly driven into cutoff and the positive going output pulse, which is coincident with trace switching, is connected to the Z-Axis Amplifier circuit through R359.

Added Mode Operation. When the ADD pushbutton is pressed, the following occurs:

1. +5 volts is applied to the cathodes of CR305 and CR307 through R371.
2. +5 volts is applied to the cathodes of CR315 and CR317 through R361.
3. —8 volts is applied to the junction of R321 and R322.

The first two actions enable both of the Channel Diode Gates so that the signal applied to the Delay-Line Driver is the algebraic sum of the Channel 1 and Channel 2 signals. The —8 volts applied to the R321 and R322 provides sufficient additional current to keep both diode gates turned on without altering the dc levels associated with the Delay-Line Driver.

Delay-Line Driver

The output from the Diode Gates is applied to the Delay-Line Driver composed of Q322 and Q324. Q322 and Q324 are connected as feedback amplifiers with R325 and R327 providing feedback from the collector to the base of their respective transistors. A sample of the signal in the collector circuit of Q322 is used for triggering in the NORM mode of trigger operation. The BW limit switch S338A connects a pi filter composed of C338, C339, L338, and L339 between the output signal lines of the Delay-Line Driver to reduce the upper —3dB bandwidth limit of the Vertical Amplifier system to approximately 20 megahertz. R335 and R336 provide reverse termination for the delay line. The TRIG VIEW switch S338B connects the output of the Trigger View Amplifier to the input of the Delay Line in place of the Delay Line Driver. This allows viewing the trigger signal present in the A Trigger Generator circuit.

Reference Feedback Amplifier

Reference Feedback Amplifier Q332 provides common mode voltage feedback from the Delay-Line Driver to allow the diode gates to be switched with a minimum amplitude switching signal. The emitter level of Q332 is connected to the junction of the Switching Multivibrator collector resistors, R371 and R361 through CR372 or CR362. The collector level of the "on" Switching Multivibrator transistor is negative and either CR362 or CR372 is forward biased. This clamps the cathode level of the forward biased shunt diodes in the applicable Diode Gate about 0.5 volt more negative than the emitter level of Q332. The level at the emitter of Q332 follows the average voltage level at the emitters of the Delay-Line Driver. The

shunt diodes are clamped near their switching level and therefore, can be switched very fast with a minimum amplitude switching signal. This maintains about the same current through the Diode Gate shunt diodes so they can be switched with a minimum amplitude switching signal regardless of the deflection signal at the anodes of the shunt diodes.

Normal Trigger Pickoff Amplifier

The trigger signal for NORM trigger operation is obtained from the collector of Q322. Normal Trigger DC Adjustment R340 sets the dc level of the normal trigger output signal so the sweep is triggered at the 0 level of the displayed signal when the Trigger Level control is set to 0. Q344 and Q346 are connected as a feedback amplifier with the signal applied to the non-inverting input and the feedback connected between the output and inverting input.

VERTICAL OUTPUT AMPLIFIER

Introduction

The Vertical Output Amplifier circuit provides the final amplification for the vertical deflection signal. Some instruments have a Vertical Output Amplifier using an integrated circuit (IC version). Other instruments have a Vertical Output Amplifier using individual transistors (discrete version). See Adjustment Locations 3a and 3b to identify the type of Vertical Output Amplifier board in your instrument. This circuit includes the Delay Line and part of the Beam Finder circuitry. Pushing the BEAM FINDER button compresses an overscanned display to within the viewing area. A schematic of the applicable Vertical Output Amplifier circuit is shown on diagram 4a or 4b at the rear of this manual.

Delay Line

Delay Line DL339 provides approximately 120 nanoseconds delay for the vertical signal to allow the Sweep Generator circuits time to initiate a sweep before the vertical signal reaches the deflection plates of the crt. This allows the instrument to display the leading edge of the signal originating the trigger pulse when using internal triggering.

Vertical Output Amplifier—Discrete Version

The discrete Vertical Output Amplifier is a three-stage paraphase amplifier. The first stage consists of transistors Q4402, Q4406, Q4412 and Q4416. The low-frequency compensation network, a portion of the high-frequency

Circuit Description—465 Service (SN B250000 & up)

compensation network and the Vertical Output Centering adjustment are in this stage. The next stage consists of transistors Q4432, Q4462, Q4442 and Q4472 with a high frequency temperature compensation network consisting of thermistor RT4448, resistor R4453, varicap CR4434 and capacitor C4444 plus the remaining portion of the high-frequency compensation network. The first stage consists of transistors Q4468, Q4482, Q4478 and Q4492 with a gain adjustment R4466. Capacitors C4464 and C4474 are built into the printed circuit board by lead and run capacitance. The BEAM FINDER switch, when pressed, limits the current to the emitters of transistors Q4432 and Q4442. This reduces the gain of the total stage, limiting the display to the display area of the crt.

Vertical Output Amplifier-IC Version

U440 is an integrated circuit amplifier that provides the final amplification for the vertical signal. R401 and R411 provide forward termination for the delay line. The components connected between pins 2 and 4 of U440 provide delay-line compensation. Components connected between pins 14 and 15 and pins 7 and 8 of U440 provide thermal compensation for the stage. The BEAM FINDER switch, when pressed, reduces the dynamic swing capabilities of the stage, thereby limiting the display to within the display area of the crt.

A AND B TRIGGER GENERATORS

Introduction

The Trigger Generator circuits produce trigger pulses to start the Sweep Generator circuits. These trigger pulses are derived either from the internal trigger signal from the vertical deflection system, an external signal connected to the external trigger input connectors, or a sample of the line voltage applied to the instrument. Controls are provided in each circuit to select trigger level, slope, coupling, and source. Since the A and B Trigger Generator circuits are virtually the same, only the A Trigger Generator circuit action and the differences between the A and B Trigger Generator circuits are explained. A schematic of these circuits is shown on diagram 5 at the back of this manual.

Trigger Source

The Trigger SOURCE switch S610 selects the source of the trigger signal. The sources available to the A Trigger Generator circuit are the signal(s) being displayed (NORM), Channel 1 (CH 1), Channel 2 (CH 2), LINE, and EXT. The EXT \div 10 (A Trigger Circuit only) position provides 10 times attenuation for the external trigger signal. The B Trigger SOURCE switch does not have a

LINE or an EXT \div 10 position, but has a STARTS AFTER DELAY position. In the LINE position, a sample voltage at the power line frequency is obtained from the secondary of power transformer T1501 in the Low Voltage Power Supply circuit. To prevent unwanted attenuation of the trigger signal by the low-frequency reject circuit, the Trigger COUPLING switch should not be in the LF REJ position when using line voltage as a trigger source.

Trigger Coupling

The Trigger COUPLING switches offer a means of accepting or rejecting certain components of the trigger signal. In the AC, LF REJ, and HF REJ positions, the dc component of the trigger signal is blocked by coupling capacitors C612 or C611. Frequency components below about 60 hertz are attenuated when AC or HF REJ coupled and below about 50 kilohertz when LF REJ coupled. The higher frequency components of the trigger signal are passed without attenuation. In the HF REJ position, the high frequency components of the trigger signal (above about 50 kilohertz) are attenuated, while the lower frequency components are passed without attenuation. The dc position passes all signals from dc to at least 100 MHz.

Input Source Follower

Transistor Q622 is a FET source follower. It provides a high input impedance (set primarily by R616) for the trigger signal and also provides isolation between the Trigger Generator circuit and the trigger signal source. Diode CR617 provides input protection for Q622 if excessively high-amplitude negative-going input signals are present. Q624 is a high-impedance, relatively constant, current source for Q622, and provides a measure of temperature compensation for Q622.

Paraphase Amplifier

U640 is a paraphase amplifier stage that converts the single-ended input from Source Follower Q622 into a push-pull output applied to the tunnel diode driver stage. Trigger Level Centering adjustment R635 sets the level at pins 14 and 15 of U640 so that the display is correctly triggered when the LEVEL control is centered. The LEVEL control varies the level at pins 14 and 15 of U640 to select the point on a trigger signal where triggering occurs.

The slope of the input signal that triggers the Sweep Generator circuit is determined by the setting of the SLOPE switch S630. When the SLOPE switch is set to the + position, the output signal present at pin 8 of U640 is in phase with the input signal and the output signal at pin 9 is inverted with respect to the input signal. When the SLOPE switch is set to the — position, the output signal at pin 8 is

inverted with respect to the input signal and the output signal at pin 9 is in phase with the input signal.

Tunnel Diode Driver

Q650 and Q652 are common-emitter amplifier stages that provide the signal currents necessary to switch the triggering tunnel diodes. CR650 and CR652 are 4.7 milliamp tunnel diodes. Quiescently (i.e., after the sweep holdoff period has passed, but before triggering), CR650 and CR652 are biased into their low voltage states. Q650 cannot provide sufficient current to switch CR650 to its high voltage state. Q652, however, can provide sufficient current to bias CR652 into its high voltage state; when Q652 next conducts triggering signal current, the anode of CR652 steps positive to an approximately +0.5 volt level. Since only approximately 1 milliamp of current is required to maintain CR652 in its high voltage state, this makes approximately 3 milliamp of current additionally available with which to switch CR650 to its high voltage state. Thus, the next time Q650 conducts a signal current, CR650 steps to its high voltage state, sending a positive pulse to the logic circuit to initiate sweep action. A Trigger Sensitivity adjustment R655 adjusts the tunnel diode bias to proper level that will not allow CR650 to be switched to its high voltage state until CR652 has been switched to its high voltage state. At the end of the sweep time and during holdoff, a negative level is applied to the anode of CR652,

thereby resetting both CR650 and CR652 to their low voltage states. The reset level remains during holdoff time to ensure that a sweep gating signal will not be generated until the sweep circuit has returned to its quiescent state.

A AND B SWEEP GENERATORS

Introduction

The A and B Sweep Generators produce sawtooth voltages which are amplified by the Horizontal Amplifier circuit to provide horizontal deflection on the crt. These sawtooth voltages are produced on command (trigger pulses) from the Trigger Generator circuits. The Sweep Generator circuits also produce gate waveforms that are used by the Z Axis Logic circuit to unblank the CRT during sweep time, and by the Sweep Logic circuit to terminate sweep generation. Fig. 3-6 shows a detailed block diagram of the A Sweep Generator circuit. The B Sweep Generator circuit is very similar to the A Sweep Generator; therefore only the differences in operation associated with the B Sweep Generator will be discussed. A schematic of both circuits is shown on diagram 6 at the rear of this manual.

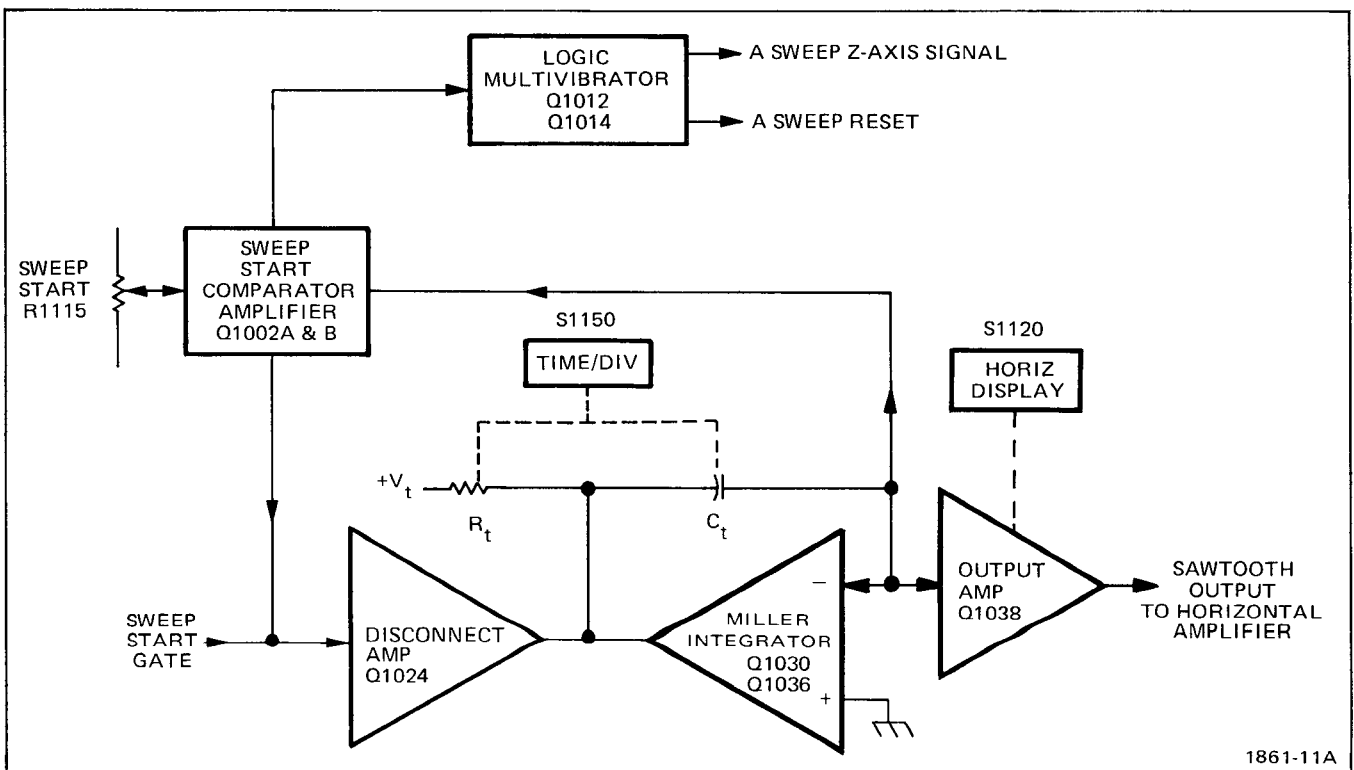

Fig. 3-6. Detailed block diagram of the A Sweep Generator.

Circuit Description—465 Service (SN B250000 & up)

Disconnect Amplifier

After holdoff, but before the next sweep, Disconnect Amplifier Q1024 conducts current through R1024 and the timing resistor R_t . This prevents timing current from changing the charge on C_t . The positive-going sweep start gate from Q864 turns off Q1024 and the timing circuit now begins to change the charge on C_t .

Sawtooth Generator

Q1030 and Q1036 compose a Miller Integrator circuit. When Q1024 turns off, C_t begins to charge through R_t . This causes the junction of C_t and R_t , the gate of Q1030, to begin to go more positive. As the gate of Q1030 goes more positive, the source of Q1030 also starts to go more positive. This biases Q1036 on harder, and its collector moves in the negative direction (less positive). This couples back through C_t and opposes the positive change at the gate of Q1030. The gate of Q1030 only changes about 10 millivolts. Although C_t tries to charge toward $+V_t$, the action of the gate of Q1030 being held virtually constant and the collector of Q1036 going more negative results in the reduction of the charge on C_t (it discharges). Since the voltage at the gate of Q1030 remains constant, the voltage across R_t remains constant. Since the voltage across R_t remains constant, the current through R_t (the current being discharged from C_t) also remains constant. The constant current being discharged from C_t results in a linear ramp across it. The resultant output signal at the collector of Q1036 appears as a negative going ramp from +13 volts to +2 volts.

When the ramp reaches +2 volts, Q1012 sends a pulse (see logic multivibrator) to U870 to initiate retrace. Q1024 turns on and its collector goes more negative. This moves the gate of Q1030 in the negative direction, which causes the voltage on the base of Q1036 to go more negative, causing its collector to go more positive. C_t now quickly charges to its quiescent state through Q1024.

Output Buffer Amplifier

The Output Buffer Amplifier is a common-base amplifier with the signal current-driven into the emitter. It provides the output sawtooth current signal to the Horizontal Amplifier and provides a measure of isolation between the Sawtooth Generator and the Horizontal Amplifier. The HORIZ DISPLAY switch connects to this stage to control the A sawtooth output in the various horizontal modes of operation. In the A and A INTEN modes of operation, the A sweep signal passes through Q1038 to the Horizontal Amplifier. However, in the MIX and B DLY'D modes, -8 volts is connected to zener diode VR1039 which sets the emitter of Q1038 to about -1.8 volts. This biases Q1038 off, preventing the A sawtooth signal from passing to the Horizontal Amplifier.

Sweep Start Amplifier

Just before the sweep starts to run down, the levels at the bases of Q1002 A and B are approximately equal. When the sweep starts to run down, the base of Q1002B goes negative, which increases the forward bias on CR1004. This in turn decreases the forward bias on CR1001, which, very shortly after the start of the sweep, becomes reverse biased to interrupt the current through Q1002A. The circuit remains in this condition until after the sweep retrace is complete. When the circuit returns to quiescence, Q1002A again begins to conduct through R1024. This sets the current through Q1024, which establishes the starting point for the sweep. The Sweep Start adjustment sets the base level of Q1002A. This level is also connected to the base of Q1062A in the B Sweep Generator except in the MIX mode of operation. This ensures that B sweep starts at the same level as A Sweep.

Logic Multivibrator

Q1012 and Q1014 compose a multivibrator. At quiescence, Q1014 is conducting and Q1012 is turned off. When the sweep starts to run, the negative-going ramp at the collector of Q1036 is coupled through the base of Q1002B and CR1004 to the cathode of CR1011. When the collector of Q1036 reaches about +2 volts the cathode of CR1011 reaches about 4 volts. CR1011 begins conducting and turns on Q1012 which then turns off Q1014. The resulting positive step at the collector of Q1012 is connected to pin 16 on U870 which initiates retrace and holdoff. The negative-going pulse at the collector of Q1014 is applied to the A Sweep Z-Axis Logic Gate to blank the crt as soon as a sweep-end command is generated.

B Sweep Generator Differences

There are three main differences between the A and B Sweep Generators. The B Sweep Output Buffer Amplifier is prevented from passing the B Sweep signal to the Horizontal Amplifier in the A and A INTEN positions of the HORIZ DISPLAY switch. There is a transistor stage connected as a constant current source in the emitter circuit of Q1062A and B (needed during MIX mode operation). The Sweep Start Level connected to the base of Q1062A is not always a fixed dc level. During MIX mode operation the A Sweep sawtooth signal is applied to the base of the Q1062A. Now, the dc level at which the B Sweep Generator will start generating its sawtooth waveform is constantly being changed by the A Sweep sawtooth. The output waveform from the B Sweep Generator takes the form of a composite sawtooth waveform, with the first and last parts occurring at a rate determined by the A Sweep Generator and the middle part occurring at a rate determined by the B Sweep Generator.

SWEEP AND Z AXIS LOGIC CIRCUIT

Introduction

The Sweep and Z-Axis Logic circuit derives the logic levels necessary to control the sequence of events associated with sweep generation and crt unblanking. The A+ and B+ gate signals are also generated in this circuit. Positive logic terminologies and symbologies will be used in the following explanation of circuit operation. A schematic of this circuit is shown on diagram 8 at the rear of this manual. See the waveforms adjacent to diagram 8 for logic levels and their time relationship to A sweep operation.

A Sweep Gate

Q862 and Q864 compose the A Sweep Gate circuit. They form an emitter coupled stage where only one transistor can be conducting at any time. The input signal to the stage is the positive-going trigger signal from the A Trigger Fire tunnel diode in the A Trigger Generator circuit. The signal at the collector of Q862 is connected to the A Z-Axis Gate circuit to control crt blanking and to generate the A+ gate signal. The signal at the collector of Q864 is connected to the emitter of the Sweep Disconnect Amplifier (Q1024) in the A Sweep Generator circuit to initiate A Sweep generation.

B Sweep Gate

Q812 and Q814 compose the B Sweep Gate circuit. They also form an emitter-coupled stage where only one transistor can be conducting at any time. The input signal to the stage is the positive-going trigger signal from the B Trigger Fire tunnel diode in the B Trigger Generator circuit. The signal at the collector of Q812 is connected to the B Z-Axis Gate circuit to control crt blanking and to generate the B+ gate signal. The signal at the collector of Q814 is connected to the emitter of the Sweep Disconnect Amplifier (Q1084) in the B Sweep Generator circuit to initiate B Sweep generation.

Sweep Control Integrated Circuit

U870 is the Sweep Control integrated circuit. Several functions are performed in this stage, depending on the mode of operation of the instrument sweep generators. The following is a brief explanation of the function associated with each pin of the IC.

Pin 1. This is the positive Auto Sense input. The signal connected here comes from the A Trigger Fire tunnel diode.

Pin 2. This is a reference input to the Auto Sense circuit. A fixed dc level established by R871 and R872 is connected here.

Pin 3. This is the + auto gate terminal. In the AUTO mode of operation, if no trigger signals are applied to pin 1 of U870 during the approximately 100 milliseconds following the end of holdoff the gate level at pin 3 steps LO to turn Q864 on which initiates a sweep.

Pin 4. Not used in this application.

Pin 5. Input terminal for negative voltage supply.

Pin 6. This is the auto gate timing terminal. R879 and C879 determine the amount of time between the end of holdoff and the generation of the auto gate.

Pin 7. The output of this terminal lights the TRIG'D light when a triggered gate has occurred.

Pin 8. This is the holdoff timing terminal. The RC network connected to this terminal (selected by the TIME/DIV switch) determines the length of holdoff time.

Pin 9. Ground terminal.

Pin 10. This is the Holdoff output terminal. The gate level present here is LO during sweep holdoff time and HI otherwise.

Pin 11. The output of this terminal lights the READY light when operating in the single sweep mode.

Pin 12. This is the single sweep mode terminal. When +5 volts is applied to this terminal the sweep operates in the single sweep mode; when the terminal is left open or grounded the sweep operates in the repetitive mode.

Pin 13. Not used in this application.

Circuit Description—465 Service (SN B250000 & up)

Pins 14 & 15. Single sweep reset terminals. Pushing the SINGL SWP button prepares the single sweep circuitry to respond to the next one triggering event. Also causes the READY light to come on.

Pin 16. This is the holdoff start input terminal. The HI sweep reset gate pulse from the sweep generators is applied here to initiate sweep holdoff.

Pin 17. This is the sweep disable output terminal. The gate level at this terminal is HI during holdoff and LO otherwise.

Pin 18. Sweep lockout input. +5 volts applied to this terminal disables all sweep action.

Pin 19. Auto mode terminal. Grounding this terminal enables auto sweep operation.

Pin 20. Input terminal for positive voltage supply.

Holdoff Timing

A resistor and capacitor network connects to pin 8 of U870. Various resistor and capacitor combinations switch into the circuit depending on the setting of the A TIME/DIV switch. At sweep end, pin 8 of U870 is released and C_{ho} starts charging. When the charge on C_{ho} causes pin 8 to reach about +4 volts, pin 17 goes HI and pin 8 steps back to LO. R1155 allows lengthening the time constant which increases holdoff time.

A Sweep Holdoff Amplifier

Q854 is the A Sweep Holdoff Amplifier. The holdoff gate waveform is applied to the base of Q854 through R858 and C858 from pin 17 of U870. When Q854 is turned off (during holdoff time), its collector is LO and CR851 is forward biased, which resets both the Arm and Fire Trigger tunnel diodes in the A Trigger Generator. When Q854 is turned on (any time other than holdoff time), its collector level is HI and CR851 is reversed biased. This allows the trigger tunnel diodes in the A Trigger Generator to respond to the next adequate triggering signal.

B Sweep Holdoff Amplifier

Q804 is the B Sweep Holdoff Amplifier. Its circuit action is identical to that described for the A Sweep Holdoff

Amplifier except that there are three gate signal sources that control the state of the stage. The three sources are the holdoff gate from pin 17 of U870 (through CR859), the collector of Q1052 in the Delay Pickoff Comparator, and the collector of Q822 in the B Latch Multivibrator (through CR809). All three gate sources must be in their LO state for B Sweep to be triggerable; any one of the sources in its HI state will disable the B Trigger Generator tunnel diodes.

B Sweep Latch

Q822 and Q828 compose the B Sweep Latch. Quiescently, (before either the A or B Sweeps have reached their maximum amplitudes) both transistors are off. Then, the sweep reset pulse from whichever sweep terminates first will be applied to the base of Q828 (A Sweep reset through CR826; B Sweep reset through CR825). The positive-going reset pulse turns on Q828 and the negative-going movement at its collector turns on Q822. The collector of Q822 in turn pulls up on the base of Q828, holding Q828 on, which causes the circuit to stay in its on or latched state. The HI at the collector of Q822 is applied to the base of the B Sweep Holdoff Amplifier (through CR809) to disable the B Trigger tunnel diodes. In the B ENDS A position of the A TRIG HOLDOFF control the HI is also applied to the holdoff start input terminal of the Sweep Control integrated circuit through C286. Thus, when B Sweep ends A Sweep ends also.

The B Latch Multivibrator is reset to its quiescent state by the LO Holdoff level present at pin 10 of the Sweep Control integrated circuit during A Sweep holdoff.

A Sweep Z-Axis Gate

Q1304 and Q1306 comprise the A Sweep Z-Axis Gate. They form an emitter-coupled stage where only one transistor can be conducting at any time. The controlling signal inputs come from the collector of Q862 in the A Sweep Gate, the blanking signal from Q1014 in the A Sweep Generator, and Q824 in the B Latch Multivibrator (only in the MIX mode of operation). The blanking signal for use in the Z-Axis Amplifier is taken from the collector of Q1306 (through CR1342). The collector signal of Q1304 is applied to the A+ gate Emitter Follower.

In all positions of the HORIZ DISPLAY switch except for B DLY'D, -8 volts is connected to the anode of CR1306. This reverse biases CR1306, which allows the gate signal at the collector of Q1306 to pass through CR1342. In the B DLY'D position of the HORIZ DISPLAY switch, -8 volts is no longer connected to CR1306. This allows CR1306 to be forward biased, which pulls up on the cathode of CR1342. This reverse-biases CR1342, which blocks the A blanking signal from reaching the Z-Axis Amplifier.

In all positions of the HORIZ DISPLAY switch except MIX, -8 volts is connected to the cathode of CR832. This keeps CR831 reverse biased and prevents the collector signal of Q824 from affecting the A Z-Axis Gate. However, in the MIX position of the HORIZ DISPLAY switch, -8 volts is no longer connected to CR832. Now, when the B Sweep ends and sets the B Sweep Latch circuit, the collector signal of Q824 (through CR831) switches the A Sweep Z-Axis Gate causing the crt display to be completely blanked. This prevents any further display of A Sweep in the MIX mode even though A Sweep may still be running.

B Sweep Z-Axis Gate

Q1324 and Q1326 compose the B Sweep Z-Axis Gate. They form an emitter-coupled stage where normally one transistor is on and the other is off. The controlling signal inputs come from the collector of Q812 in the B Sweep Gate and the blanking signal from Q1074 in the B Sweep Generator. The blanking signal for use in the Z-Axis Amplifier is taken from the collector of Q1326 (through CR1344). The collector signal of Q1324 is applied to the B+ Gate Emitter follower.

In the A position of the HORIZ DISPLAY switch, -8 volts is applied to the cathode of CR1347, which causes CR1345 to be back biased. The collector of Q1326 is pulled positive through R1326 and CR1326, which in turn back biases CR1344, preventing the B Sweep Z-Axis Gate from affecting crt unblanking. In the MIX and A INTEN positions of the HORIZ DISPLAY switch, -8 volts is removed from the cathode of CR1347 and applied to the anode of CR1326. This forward biases CR1345 and reverse biases CR1326. Diode CR1344 is still reverse biased, but when B Sweep starts, the collector of Q1326 steps negative enough to forward bias CR1344 and add a slight amount of unblanking to the A Sweep unblanking already present. This provides a measure of intensification for the B Sweep portion of an A INTEN or MIX display. In the B DLY'D position of the HORIZ DISPLAY switch, -8 volts is applied to the cathode of CR1347 and the anode of CR1326. This reverse biases both CR1345 and CR1326, which allows the full B Sweep unblanking signal to pass through CR1344. The A Sweep Z-Axis Gate output diode CR1342 is held reverse biased and the only unblanking signal present at the input to the X-Axis Amplifier will be the B Sweep signal.

A+ Gate and B+ Gate Emitter Followers

Q1314 and Q1334 are emitter followers providing the A+ GATE and the B+ GATE output signals available at the instrument rear panel. The output signals are positive-going rectangular waveforms, approximately 5.5 volts in amplitude. The amplitude is set in the collectors of Q1304 and Q1324. For example, when Q1304 is conducting the

base of Q1314 can go no more negative than approximately -0.7 volt (limited by CR1304). When Q1304 is not conducting, the base of Q1314 rises to the decoupled $+5$ volts power supply level through R1304. Diodes CR1315, CR1316, CR1335, and CR1366 provide protection against accidental application of damaging voltage levels to the A+ GATE and B+ GATE output connectors.

HORIZONTAL AMPLIFIER

Introduction

The Horizontal Amplifier circuit provides the output signals to the crt horizontal deflection plates. The signal applied to the input of the Horizontal Amplifier is determined by the TIME/DIV switch and the HORIZ DISPLAY switch. The signal can come from either the sweep generators within the instrument or some external signal applied to the CH 1 OR X input connector (X-Y mode of operation). The Horizontal Amplifier also contains the X10 magnifier, horizontal positioning, and some beam finder circuitry. Fig. 3-7 shows a detailed block diagram of the Horizontal Amplifier circuit. A schematic of this circuit is shown on diagram 9 at the rear of this manual.

X-Axis Amplifier

In all positions of the TIME/DIV switches except X-Y, the input signal to the base of Q1224 will be sawtooth waveforms from the sweep generators. In the X-Y mode however, the sweeps are disabled and the signal applied to Q1224 comes from the Channel 1 Preamp via the X-Axis Amplifier. This stage includes Q1214, Q1218 and their associated circuitry.

Q1214 is connected as a feedback amplifier with R1214 as the feedback element. The input resistance is made up of R1211 and the gain-setting adjustment of R1215. When not operating in the X-Y mode, the base of Q1214 rises toward the $+15$ volt supply but is clamped at approximately $+5.7$ volts by CR1218 and R1218. This reverse biases the base-emitter junction of Q1214. The base of Q1218 also rises to approximately $+5.7$ volts. With the junction of R1202-R1219 at approximately 0 volt, Q1218 is also biased off.

When the TIME/DIV switches are set to the X-Y position (fully counterclockwise), -8 volts is applied to the junction of R1212 and R1217. Also, $+5$ volts is applied to the emitter circuit of Q1218 through CR1202. This biases the Z-Axis Amplifier circuit into conduction. At the same time, $+5$ volts is applied to the Channel 1 Scale-Factor

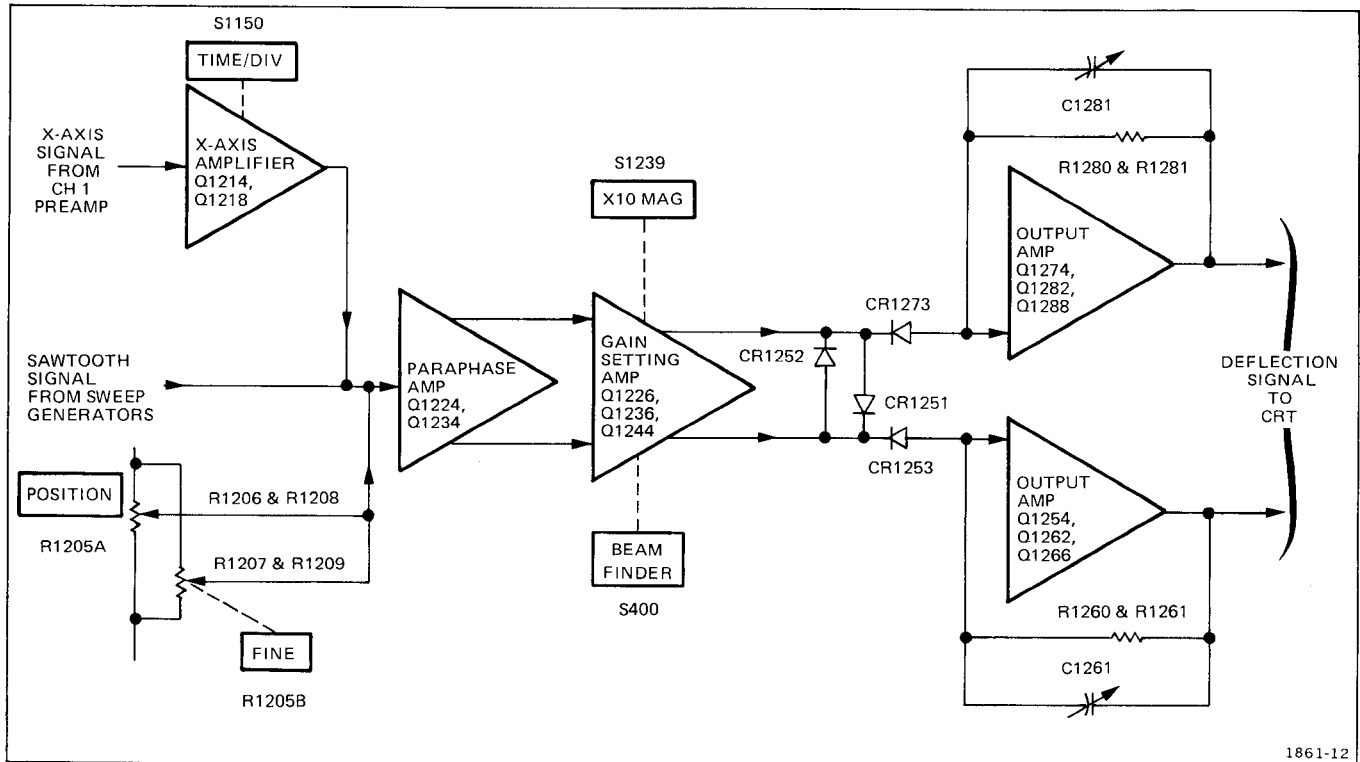

Fig. 3-7. Detailed block diagram of the Horizontal Amplifier.

Switching Amplifier circuit (through CR1201) and to pin 18 of the Sweep Control integrated circuit U870. This enables both scale-factor indicating circuits at the same time and disables sweep generation.

Input Paraphase Amplifier

Q1224 and Q1234 compose the Input Paraphase Amplifier. This is an emitter-coupled amplifier stage that converts the single-ended input signal to a push-pull output signal. The signal at the collector of Q1224 is opposite in phase to the input signal. The signal at the collector of Q1234 is in phase with the input signal. Thermistor RT1230 reduces in value with increases in ambient temperature to increase the gain of the stage. This compensates for slight changes in amplifier gain that occur as operating temperatures vary. R1205A and R1205B are the Horizontal POSITION and FINE controls, respectively. The FINE control has approximately one tenth the range of the POSITION control and provides fine adjustment of a magnified display.

Gain Setting Amplifier

Q1226 and Q1236 are an emitter coupled push-pull amplifier stage. Q1244 is a constant current supply for the stage. The gain of the Horizontal Amplifier is controlled by adjusting the resistance connected between the emitters

of this stage. The X1 Gain adjustment R1237 adjusts unmagnified horizontal gain and the X10 Gain adjustment R1238 adjusts magnified horizontal gain. Magnifier Registration adjustment R1225 balances quiescent dc current in Q1226 and Q1236 so that a center screen display does not change position when the X10 magnifier is turned on.

When the BEAM FINDER pushbutton is pressed, R1249 is connected to ground. This reduces the current supplied through Q1244, which has the effect of shifting the operating level at the collector of Q1244 in the positive direction. This causes the point at which the Horizontal Amplifier limits to decrease, thereby ensuring that an overscanned display will remain within the viewing area of the crt.

Output Amplifier

The push-pull signal from the Gain Setting Amplifier is connected to the Output Amplifier through CR1253 and CR1273. Each half of the Output Amplifier can be considered as a single-ended feedback amplifier, which amplifies the signal current at the input to produce a voltage output to drive the horizontal deflection plates of the crt. The amplifiers have a low input impedance and require very little voltage change at the input to produce the desired output voltage change. The Output Amplifiers

are limited from overdrive by CR1251, CR1252, CR1253, and CR1273. The input diodes CR1253 and CR1273 become back-biased when the signal level at either input becomes too positive, and the diodes connected back to back between the two signal paths ensure that the signal amplitude side to side will be limited to a maximum of about 0.7 volt.

Transistors Q1254 and Q1274 are inverting amplifier stages whose collector signals drive the emitters of complementary amplifiers Q1262-Q1266 and Q1282-Q1286 respectively. C1256, C1262, and C1282 provide a signal path for fast ac signal current from one side of the amplifier to the other. R1260-R1261 and R1280-R1281 are the feedback elements in the amplifier with C1261 and C1281 providing high-frequency compensation. The output signal from Q1262-Q1266 drives the right crt deflection plate, while the signal from Q1282-Q1286 drives the left.

(crt). Fig. 3-8 shows a detailed block diagram of the CRT circuit. A schematic of this circuit is shown on diagram 10 at the rear of this manual.

High-Voltage Oscillator

Q1418 and associated circuitry compose the high-voltage oscillator that produces the drive for high-voltage transformer T1420. When the instrument is turned on, current through Q1416 provides forward bias for Q1418. Transistor Q1418 conducts and its collector current increases, which develops a voltage across the collector winding of T1420. This produces a corresponding voltage increase in the feedback winding of T1420, which is connected to the base of Q1418, and Q1418 conducts even harder. Eventually the rate of collector current increase in Q1418 becomes less than that required to maintain the voltage across the collector winding, and the output voltage drops. This turns off Q1418 by way of the feedback voltage to the base. The voltage waveform at the collector of Q1418 is a sine wave of the resonant frequency of T1420. Q1418 remains off while the field collapses in the primary of T1420. When the field is collapsed sufficiently, the base of Q1418 becomes forward biased into conduction again and the cycle begins anew. The amplitude of

CRT CIRCUIT

Introduction

The CRT circuit provides the voltage levels and control circuits necessary for operation of the cathode-ray tube

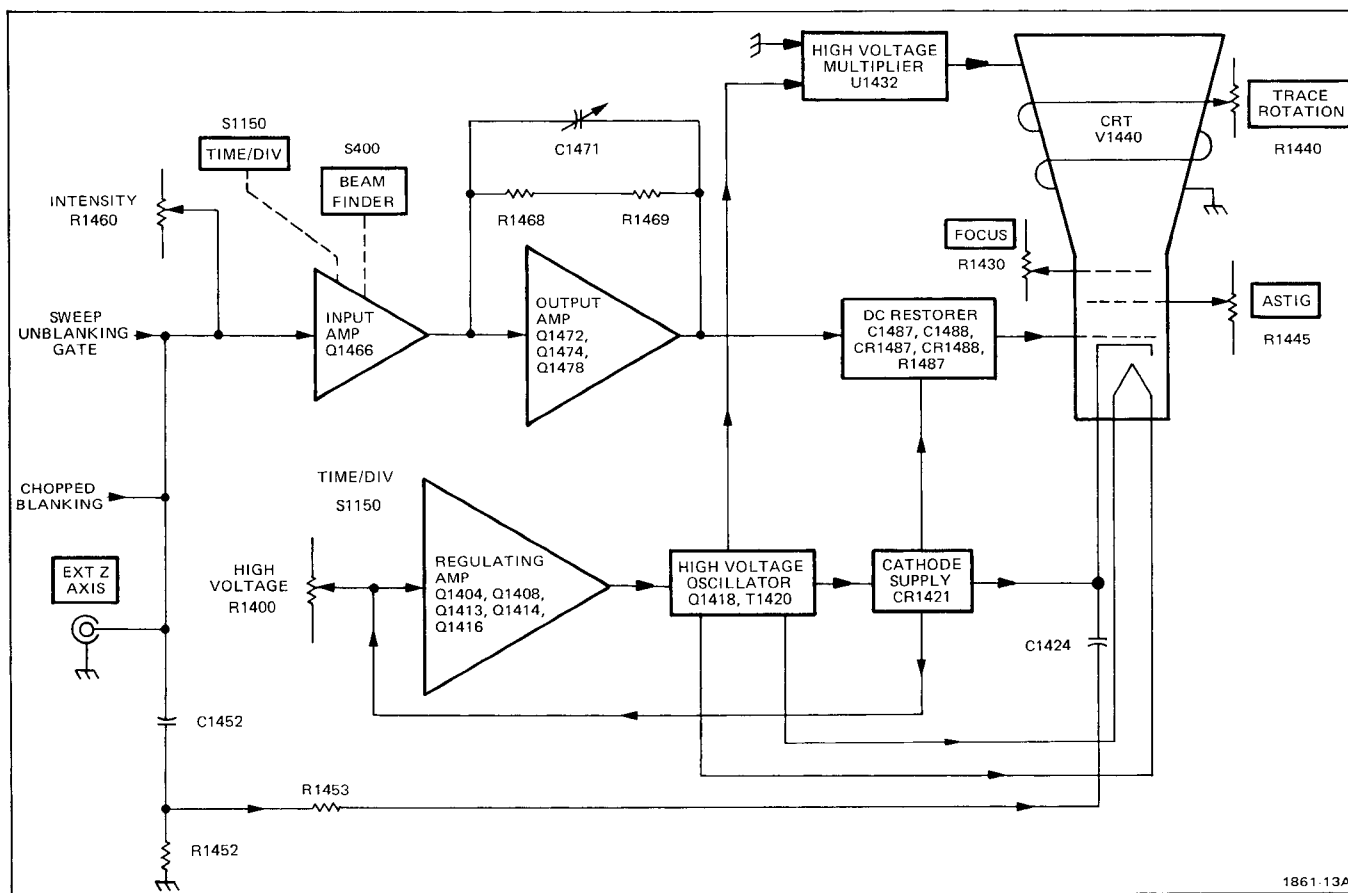

Fig. 3-8. Detailed block diagram of the CRT and Z-Axis circuits.

Circuit Description—465 Service (SN B250000 & up)

substantiated oscillation depends upon the average current delivered to the base of Q1418. The frequency of oscillation is approximately 50 kilohertz. Fuse F1419 protects the unregulated +15 volt supply in the event the High-Voltage Oscillator stage becomes shorted. C1419 and L1419 decouple the unregulated +15 volt supply and prevent the current changes present in the circuit from affecting the +15 volt regulator.

High-Voltage Regulator

Feedback from the crt cathode —2450 volt supply is applied to the base of Q1404 through R1431D. Any change in the level at the base of Q1404 produces an error signal at the collector of Q1404, which is amplified by Q1408 and Q1416 and applied to the base of Q1418 through the feedback winding of T1420.

Regulation occurs as follows. If the output voltage at the —2450 volt test point starts to go positive (less negative), this positive-going change is applied to the base of Q1404. Q1404 conducts harder, which in turn causes Q1408 and Q1416 to conduct harder. This results in greater bias current to the base of Q1418 through the feedback winding of T1420. Now, Q1418 is biased closer to its conduction level so that it comes into conduction sooner to produce a larger induced voltage in the secondary of T1420. This increased voltage appears as a more negative voltage at the —2450 volt test point to correct the original positive-going change. By sampling the output from the crt cathode supply in this manner, the total output of the High-Voltage Supply is held relatively constant.

The output voltage level of the High-Voltage Supply is controlled by the High Voltage Adjustment R1400 in the base circuit of Q1404. This adjustment sets the conduction of Q1404 to a level that establishes a —2450 volt operating potential at the crt cathode.

Q1413 and Q1414 compose an overvoltage protection circuit. If the crt cathode supply approaches approximately —3000 volts, the voltage level at the emitter of Q1416 will be very close to —6 volts. Normally Q1413 and Q1414 are biased off and do not conduct. When the voltage level at the emitter of Q1416 reaches approximately —6 volts, Q1413 is biased into conduction which in turn biases Q1414 on. Q1414 now starts to turn off Q1416. This reduces the base drive to Q1418 and prevents the amplitude of oscillations from increasing. This prevents the crt cathode supply from going more negative than approximately —3000 volts.

High-Voltage Rectifiers and Output

The high-voltage transformer T1420 has two output windings. One winding provides heater voltage for the cathode-ray tube. The heater voltage can be supplied from the High-Voltage Supply, since the cathode-ray tube has a very low heater current drain. The cathode and heater of the crt are connected together to elevate the heater and prevent cathode-to-heater breakdown. One high-voltage winding provides both the negative cathode potential and the positive anode accelerating voltage. The crt grid bias voltage is derived by a dc restorer circuit that uses a sample of the signal in the high-voltage winding in conjunction with dc levels supplied by the Z-Axis Amplifier and the negative cathode potential.

The positive accelerating potential is supplied by High Voltage Multiplier, U1432. Regulated output voltage is approximately +15,500 volts. The negative cathode potential is supplied by half-wave rectifier CR1241. Voltage output is —2450 volts. Voltage variations in this supply are monitored by the High-Voltage Regulator circuit to provide a regulated high-voltage output.

CRT Control Circuits

Focus of the crt display is controlled by FOCUS control R1430. ASTIG adjustment R1445, which is used in conjunction with the FOCUS control to provide a well-defined display, varies the positive level on the astigmatism grid. Geometry adjustment R1442 varies the positive level on the horizontal deflection plate shields to control the overall geometry of the display.

Two adjustments control the trace alignment by varying the magnetic field around the crt. Y-Axis adjustment R1446 controls the current through L1446, which affects the crt beam after vertical deflection, but before horizontal deflection. Therefore, it affects only the vertical (Y) components of the display. TRACE ROTATION adjustment R1440 controls the current through L1440 and affects both vertical and horizontal rotation of the beam.

Z-Axis Amplifier

The Z-Axis Amplifier circuit controls the crt intensity level from several inputs. The effect of these input signals is to either increase or decrease the trace intensity, or to completely blank portions of the display. The input transistor Q1466 is a current-driven, low input impedance amplifier. It provides termination for the input signals as well as isolation between the input signals and the following stages. The current signals from the various

control sources as connected to the emitter of Q1466 and the algebraic sum of the signals determines the collector conduction level.

Q1472, Q1474, and Q1478 compose a feedback amplifier stage; R1468 and R1469 are the feedback elements. C1469 and C1471 provide high frequency compensation. Q1472 is an emitter follower providing drive to complementary amplifier Q1474-Q1478. Diodes CR1468, CR1472, and CR1476 provide protection in the event of high-voltage arcing.

In the .1 s, .2 s, .5 s, and X-Y positions of the TIME/DIV switch, +5 volts is connected to the anode of CR1463. This limits the effective range of the INTENSITY control to reduce the unblanking capabilities of the amplifier, thereby reducing the possibility of inadvertently burning the crt phosphor.

When the BEAM FINDER pushbutton is pressed, two things occur: First, +15 volts is applied to the anode of CR1465 which lifts the emitter of Q1466 sufficiently positive to ensure there will be no conduction through Q1466. Secondly, R1470 becomes connected to -8 volts through R1477 which establishes a fixed predetermined unblanking level at the output of the amplifier. Thus, the INTENSITY control and all of the input unblanking signals have no control over the intensity level of the crt display when the BEAM FINDER pushbutton is pressed.

DC Restorer Circuit

C1488, C1487, CR1483, CR1487, CR1488, and R1486 form a dc restorer circuit. All dc levels in this circuit are referenced to the negative potential of the crt cathode. The voltage difference across R1486 approximately equals the voltage swing present at the junction of CR1482 and CR1483. The control grid end of R1486 is more negative than the end connected to CR1488. The amplitude of the voltage swings present at the junction of CR1482 and CR1483 is determined by the voltage levels established by the Z-Axis Amplifier and the CRT Bias adjust circuit.

CALIBRATOR

Introduction

The Calibrator circuit produces a square-wave output signal with accurate voltage and current amplitudes. This output is available as a voltage or current at the

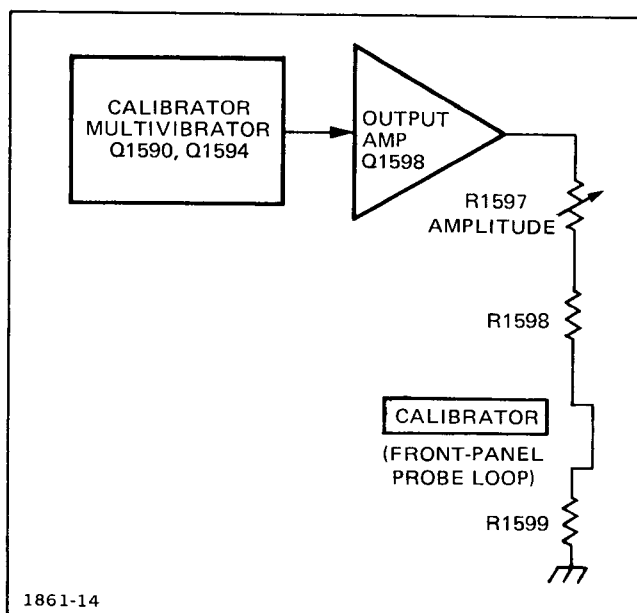

Fig. 3-9. Detailed block diagram of the Calibrator circuit.

CALIBRATOR current loop on the instrument front panel. Fig. 3-9 shows a detailed block diagram of the Calibrator circuit. A schematic of this current is shown on diagram 11 at the back of this manual.

Multivibrator

Q1590 and Q1594 along with their associated circuitry compose an astable multivibrator. The basic frequency of the multivibrator is approximately 1 kilohertz and is essentially determined by the resistor and capacitor combination of C1592, R1591, and R1593. Transistors Q1590 and Q1594 alternately conduct, producing a square-wave output signal, which is taken from the collector of Q1594. The amplitude of the square wave is limited in the negative direction by the base-emitter junction of Q1598 and in the positive direction by CR1596.

Output Amplifier

The output signal from the Multivibrator overdrives Output Amplifier Q1598 to produce an accurate square wave at the output. When the base of Q1598 goes positive, Q1598 is cut off and the collector level drops to ground. When the base goes negative Q1598 is biased into saturation and the collector of Q1598 rises positive to about +5 volts. Amplitude adjustment R1597 adjusts the resistance between the collector of Q1598 and ground to determine the amount of current allowed to flow, which in turn determines the voltage developed across R1599.

A TRIGGER VIEW AMPLIFIER

Introduction

The A Trigger View Amplifier circuit amplifies a sample of the signal present in the A Trigger Generator circuit and passes it on to the Vertical Output Amplifier for display on the crt when the TRIG VIEW pushbutton is pressed. This provides a method of making a quick and convenient check of the signal being used to trigger the A Sweep Generator and is intended primarily to be used to check the signal applied to the A EXTERNAL TRIGGER INPUT connector. Fig. 3-10 shows a detailed block diagram of the A Trigger View Amplifier circuit. A schematic of this circuit is shown on diagram 11 at the back of this manual.

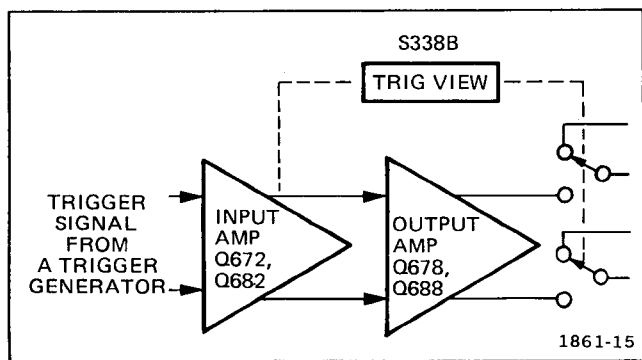

Fig. 3-10. Detailed block diagram of the Trigger View Amplifier.

Amplifier

The amplifier consists of two emitter-coupled push-pull amplifier stages. The emitter source voltage for Q672 and Q682 is switched on and off by the TRIG VIEW pushbutton. With the TRIG VIEW pushbutton not pressed, the emitters of Q672 and Q682 are returned to -8 volts through R691. This reverse-biases the base-emitter junctions of the transistors, preventing any loading of the A Trigger Generator circuit. When the TRIG VIEW pushbutton is pressed, the emitters of Q672 and Q682 are returned to +15 volts through R690. This forward biases Q672 and Q682 to allow signal amplification. R675 adjusts for correct dc balance in the circuit.

Normally, the output of the Vertical Switching Amplifier is applied to the input of the Delay Line. When the TRIG VIEW pushbutton is pressed, the signal from the Vertical Switching Amplifier is removed and the output from the A Trigger View Amplifier is applied in its place.

LOW-VOLTAGE POWER SUPPLY

Introduction

The Low-Voltage Power Supply circuit provides the operating power for this instrument from five regulated supplies and one unregulated supply. Electronic regulation is used to provide stable, low-ripple output voltages. Fig. 3-11 shows a detailed block diagram of the Power Supply circuit. A schematic of this circuit is shown on diagram 12 at the back of this manual.

Power Input

Power is applied to the primary of transformer T1501 through Line Fuse F1501, POWER switch S1501, Thermal Cutout S1502, Line Voltage Selector switch S1503, and the Regulating Range Selector Assembly. Line Voltage Selector switch S1503 connects the split primaries of T1501 in parallel for 115 volt nominal operation, or in series for 230 volt nominal operation. Line Fuse F1501 should be changed to the correct value to provide the correct protection for each nominal line voltage. See Electrical Parts List for correct fuse values.

The vacant windings between pins 10, 11 and 12 of T1501 are intended for use with the optional Inverter Circuit Board (Option 7) or DM-series Digital Multimeters. Option 7 allows the instrument to be operated from an external dc power source or an 1106 Power Supply. Option 7 and DM-series Digital Multimeters cannot be used at the same time.

Secondary Circuit

The -8 volt, +5 volt, +15 volt, and +55 volt supplies are series-regulated supplies. U1524A and B and U1554A and B are 2 channel high-gain amplifier cells with differential inputs. These amplifiers monitor voltage variations in the output voltages and supply correction signals to the series regulating transistors.

Current limiting circuits provide short circuit protection for each of the regulated supplies. The following discusses the +55 volt current limit circuit. The other current limiting circuits work in a similar manner.

In the +55 volt supply Q1536 is normally biased off. Under normal conditions the base of Q1536 sets at about +55 volts. As supply current increases the voltage drop across R1534 increases. This increasing voltage is coupled through the base of Q1534 to the voltage divider

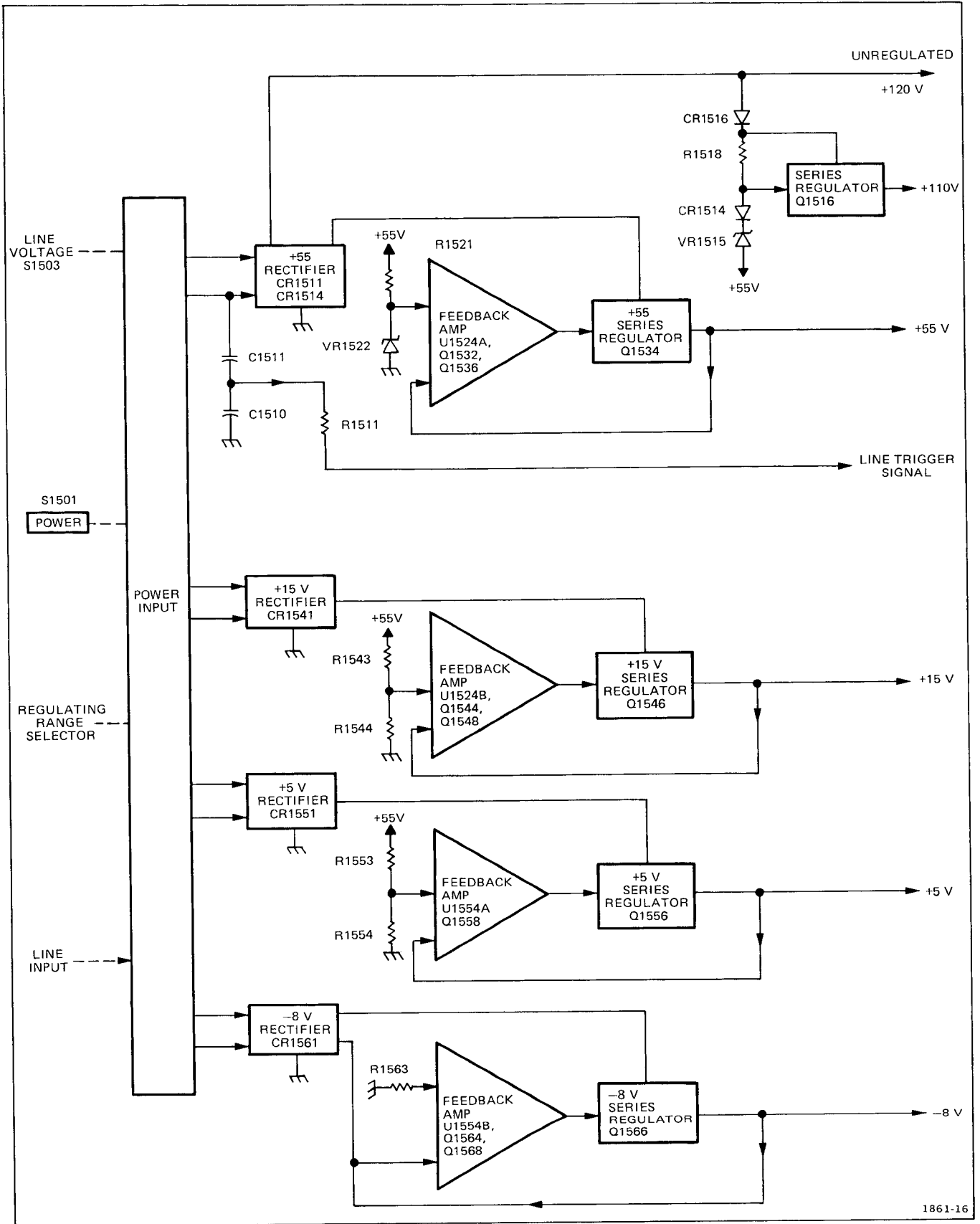

Fig. 3-11. Detailed block diagram of the Low Voltage Power Supply.

Circuit Description—465 Service (SN B250000 & up)

composed of R1532 and R1533 which causes the base of Q1536 to go more positive. When the supply current increases sufficiently Q1536 turns on. The collector of Q1536 moves in the negative direction which begins turning off Q1532 and Q1534. Transistor Q1534 must continue conducting some current when the supply is limited, in order to drop enough voltage across R1534 to keep Q1536 biased on. The supply output voltage can be any value between its regulated value and 0 volt, depending on the load it is trying to supply (see Fig. 3-12). The limiting transistors for the other supplies are:

+15 V	Q1548
+5 V	Q1558
-8 V	Q1568
+110 V	Q1518

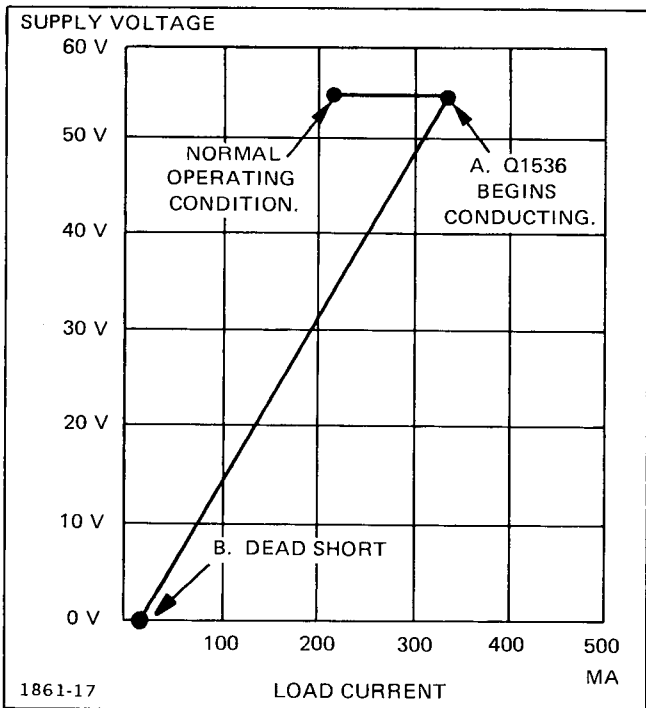

Fig. 3-12. Foldover circuit action.

Fig. 3-12 shows the action of the current limit (foldover) circuit. Q1536 begins conducting at point A. At point B the supply is directly shorted to ground through a current meter.

C1510, C1511, and R1511 compose a wave-shaping circuit that provides a sample of the ac voltage present in the secondary of T1501 to the trigger circuitry for use in the LINE positions of the Trigger SOURCE switches. CR1512 provides a relatively fast discharge path for C1542 when instrument power is turned off.

FAN MOTOR CIRCUIT

The fan motor used in the 465 is a brushless dc fan motor using Hall Effect devices. The fan motor circuitry varies the rotational speed of the fan with variations in operating temperature. When the ambient temperature increases, the value of thermistor RT1696 reduces. This biases Q1698 on harder to conduct more current through the Hall devices. Higher currents through the Hall devices causes the potential difference across them (for instance, between pins 6 and 8 of the fan) to increase. This potential difference biases one of a pair of transistors on and the other off. For instance, if pin 8 is more positive than pin 6 of the fan, Q1690A will be on and Q1690D will be off. The higher the potential difference between pin 8 and pin 6 the harder the on transistor will be conducting. The harder the transistor is conducting, the faster the fan rotates.

MAINTENANCE

Introduction

This section of the manual contains information for use in preventive maintenance, troubleshooting and corrective maintenance.

CABINET AND RACK ADAPTER REMOVAL

Standard Cabinet Removal

The standard instrument cabinet can be removed in the following manner:

1. Disconnect the instrument power cord from the power source.
2. Install the front-panel cover and set the instrument face on a flat surface.
3. Unwrap the power cord from the instrument feet.
4. Remove the 6 screws indicated in Fig. 4-1 and remove the rear cabinet frame with feet and screws from the instrument as an intact assembly.

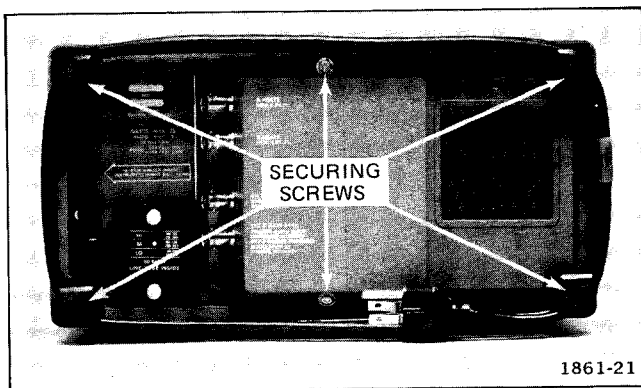

Fig. 4-1. Removing the wrap around cabinet.

5. Lift the cabinet up until it is separated from the instrument and power cord.

WARNING

Dangerous potentials exist at several points throughout this instrument. When the instrument is operated with the cabinet removed, do not touch exposed connections or components. Some transistors may have elevated cases. Disconnect power before cleaning the instrument or replacing parts.

Standard Cabinet Installation

The standard instrument cabinet should be installed in the following manner:

1. Disconnect the instrument power cord from the power source.
2. If the Vertical Output circuit-board cover is not in place, install the cover on the top of main chassis. Where parts were removed or replaced check all sections of the instrument for proper assembly. It may be helpful to use the diagrams in Section 9, Mechanical Parts List, for the locations of parts.
3. 465 DM-series only—If the DM-series main circuit-board is not in place, install the board on the main chassis.
4. Install the front-panel cover and set the instrument face on a flat surface.
5. Place the cabinet handle against the bottom of the cabinet (bottom of cabinet is nearest the carrying handle pivot points).
6. Pull the power cable through the cabinet and slide the cabinet over the instrument using care to avoid pinching cables or damaging components that protrude from circuit boards.
7. Using both hands, press lightly on the top and bottom sides of the cabinet until the front edge of the cabinet is inserted into the braided gasket groove around the full periphery of the front cabinet frame.

Maintenance—465 Service (SN B250000 & up)

8. Pull the power cord through the rear cabinet frame, align a cutout portion in the frame for proper fit at the regulating-range selector cover and work the frame into place.

9. Set the feet and screws in place and exert a light downward pressure on the rear cabinet frame with 1 hand and arm. Press lightly on the top and bottom sides of cabinet with the other hand, checking that cabinet edge is properly seated in the gasket groove of both front and rear frames. Continue to exert a downward pressure and tighten the 6 screws of the rear frame to a snug fit. Do not over-tighten these screws.

The standard cabinet protects this instrument from dust in the interior and also provides protection to personnel from the operating potentials present. In addition, the cabinet reduces the emi (electromagnetic interference) radiation from the instrument and interference to the display due to other equipment.

The front-panel cover provides a dust-tight seal around the front panel and protects the front panel when storing or transporting the instrument.

Rack Adapter Removal

The Rack Adapter can be removed from the instrument in the following manner:

1. Remove the hardware that fastens the Rack Adapter to the rack and pull the adapter partially out. Disconnect the instrument power cord from the power source and remove any interconnecting cables.

NOTE

If it is desired to tilt the Rack Adapter and instrument, remove a screw from the rear of each slide section mounted to the Rack Adapter. These securing screws are an important part of the mounting and should be installed when tilt operation is not necessary.

2. Remove the Rack Adapter, with instrument, from the rack and set the bottom of the complete assembly on a flat surface.

3. Remove 2 setscrews from the top, front of Rack Adapter chassis, (A 0.125-inch Allen wrench is required to remove the setscrews.) It may be helpful to use the diagrams in Section 9, Mechanical Parts List for the locations of parts.

4. Remove 10 screws that hold the rear support plate to an angle bracket on one side, to the Rack Adapter chassis on the opposite side, and to the rear of the instrument. Remove the rear support-plate and blue-plastic rear frame.

5. Slide the instrument forward through the adapter cabinet, using both hands (front and rear) to lift and guide the instrument until separated from the Rack Adapter.

WARNING

Dangerous potentials exist at several points throughout this instrument. When the instrument is operated with the Rack Adapter removed, do not touch exposed connections or components. Some transistors may have elevated cases. Disconnect power before cleaning the instrument or replacing parts.

Rack Adapter Installation

The Rack Adapter should be installed in the following manner:

1. Disconnect the instrument power cord from the power source.

2. If the Vertical Output circuit-board cover is not in place, install the cover on the top of the 465 main chassis. Check all sections of the instrument where parts were removed or replaced for proper assembly. It may be helpful to use the diagrams in Section 9, Mechanical Parts List for the locations of parts.

3. Set the bottom of the Rack Adapter on a flat surface, pull the power cord through the cabinet portion of the Rack Adapter and slide the instrument rearward using both hands (front and rear) to lift and guide the instrument until fully inserted. Use care to avoid pinching cables or damaging components that protrude from circuit boards.

4. Check that the front edge of the cabinet portion of the Rack Adapter is inserted into the braided gasket groove around the full periphery of the instrument front-frame. Pull the power cord through the blue-plastic rear frame, align a cutout portion in the plastic frame for proper fit at the regulating-range selector cover, and work the frame into place.

5. Apply the rear support bracket to the rear of the Rack Adapter. Install, without tightening, 6 screws that secure the rear support bracket through the blue-plastic frame to the rear of the instrument and 4 screws that secure the rear support bracket to an angle bracket and to the Rack Adapter chassis.

6. Check that all parts of the complete assembly are properly seated, then tighten to a snug fit the screws at the rear of the instrument and the screws at the adapter chassis. Do not overtighten these screws.

7. Install 2 setscrews at the top-front of the Rack Adapter chassis. (A 0.125-inch Allen wrench is required to install the setscrews.)

8. Mount the Rack Adapter slide sections to the rack slide assemblies, connect the power cord, connect any interconnecting cables, push the Rack Adapter into final operating position, and install the adapter-to-rack hardware.

The Rack Adapter cabinet (Part No. 016-0556-00) for the 465 provides the proper electrical environment for the instrument, reduces dust collection, reduces handling damage to a minimum, and provides a means for mounting the instrument solidly to a surface such as a rack or console.

PREVENTIVE MAINTENANCE

Introduction

Preventive maintenance consists primarily of cleaning and visual inspection. When performed on a regular basis, preventive maintenance can prevent instrument breakdown and ensure the reliability of this instrument. The severity of the environment to which the 465 is subjected will determine the frequency of maintenance. A convenient time to perform preventive maintenance is just prior to recalibration of the instrument.

Cleaning

The cabinet provides protection against dust in the interior of the instrument. Operation without the cabinet in place necessitates more frequent cleaning. The front cover provides a measure of dust protection for the front panel and the crt face. The front cover should be installed when storing or transporting the instrument.

Interior. Accumulation of dust and dirt should be removed as often as operating conditions require. Dirt can cause overheating and component breakdown. Dirt on components acts as an insulating blanket and prevents efficient heat dissipation. It also provides an electrical conduction path which can result in instrument failure especially under high humidity conditions. The best way to clean the interior is to blow off the accumulated dust with dry, low-pressure air (approximately 9 lb/in²). Remove any dirt which remains with a soft brush or a cloth dampened with a mild detergent and water solution. A cotton-tipped applicator is useful for cleaning in narrow spaces or for cleaning ceramic terminal strips and circuit boards.

CAUTION

Avoid the use of chemical cleaning agents which might damage the plastics used in this instrument. Do not use chemicals which contain acetone, benzene, toluene, xylene, petroleum ether, white kerosene, carbon tetrachloride, methylene chloride, trichloroethane, trichlorotrifluoroethane (freon 113, -tf, -ta, -te, -tmc) and trichlorethylene. Recommended cleaning agents are isopropyl alcohol, kelite (1 part kelite, 20 parts water), and a solution of 1% mild detergent and 99% water. In the absence of these cleaners it is safe to use ethyl alcohol (methanol).

Maintenance—465 Service (SN B250000 & up)

Most spray circuit coolants contain freon 12 as a propellant. Because many freons adversely affect switch contacts, check the contents and brand name before using a spray coolant. Use the following brand names for an acceptable coolant: Artic Freeze, Quik-Freeze, and Can-O-Gas. Do not use Zero Mist brand of circuit coolant. The only recommended circuit coolants for the volts/division attenuators are dry ice (CO₂) or isopropyl alcohol.

Switch Contacts. Most of the switching in the 465 is accomplished with circuit-board mounted, cam-actuated contacts. Care must be exercised to preserve the high-frequency characteristics of these switches. Seldom is switch maintenance necessary, but if it is required, observe the following precautions.

Cleaning the switch contacts should only be done using isopropyl alcohol, especially in the area of the vertical attenuator boards. Carbon-based solvents will damage the polyphenylene oxide boards used for the attenuators. Apply the isopropyl alcohol with a camel hair brush. Do not use cotton swabs as they tend to snag on contacts, possibly causing damage, and hold strands of cotton, causing intermittent electrical contact.

Exterior. Loose dust accumulated on the outside of the oscilloscope can be removed with a soft cloth or small paint brush. The paint brush is particularly useful for dislodging dirt on and around the front-panel controls. Dirt which remains can be removed with a soft cloth dampened in a mild solution of detergent and water. Abrasive cleaners should not be used.

CRT. Two plastic light filters, one blue and one clear, are provided with the oscilloscope. Clean the light filter and the crt face with a soft lint-free cloth dampened with denatured alcohol or a mild water and detergent solution. The optional crt mesh filter can be cleaned in the following manner:

1. Hold the filter in a vertical position and brush lightly with a number 7 soft watercolor brush to remove light coatings of dust and lint.
2. Greasy residues or dried-on dirt can be removed with a solution of warm water and a neutral pH liquid detergent. Use the brush to lightly scrub the filter.
3. Rinse the filter thoroughly in clean water and allow to air dry.

4. If any lint or dirt remains, use clean low-pressure air (approximately 9 lb/in²) to remove. Do not use tweezers or other hard cleaning tools on the filter as the special finish may be damaged.

5. When not in use, store the mesh filter in a lint-free dust-proof container such as a plastic bag.

Air Filter. The air filter should be visually checked every few weeks and cleaned or replaced if dirty. More frequent inspections are required under severe operating conditions. The following procedure is suggested for cleaning the filter. If the filter is to be replaced, order new air filters from your local Tektronix Field Office or representative; order by Tektronix Part Number 378-0044-01.

1. Remove the filter by pulling it out of the retaining frame on the rear panel. Be careful not to drop any of the accumulated dirt into the instrument.
2. Flush the loose dirt from the filter with a stream of hot water.
3. Place the filter in a solution of mild detergent and hot water and let it soak for several minutes.
4. Squeeze the filter to wash out any dirt which remains.
5. Rinse the filter in clear water and allow it to dry.
6. Coat the dry filter with an air-filter adhesive (available from air conditioner supplier, or order Tektronix Part Number 006-0580-00).
7. Let the adhesive dry thoroughly.
8. Re-install the filter in the retaining frame.

Visual Inspection

The instrument should be inspected occasionally for such defects as broken connections, broken or damaged ceramic strips, improperly seated semiconductors, damaged or improperly installed circuit boards, and heat-damaged parts.

The corrective procedure for most visible defects is obvious; however, particular care must be taken if heat-damaged components are found. Overheating usually indicates other trouble in the instrument; therefore, it is important that the cause of overheating be corrected to prevent recurrence of the damage.

Lubrication

The fan motor and most of the potentiometers used in the 465 are permanently sealed and generally do not require periodic lubrication. The switches used in the 465, both cam- and lever-type, are installed with proper lubrication applied where necessary and will rarely require any additional lubrication. A regular periodic lubrication program for the 465 is not recommended.

Semiconductor Checks

Periodic checks of the transistors and other semiconductors in the oscilloscope are not recommended. The best check of semiconductor performance is actual operation in the instrument.

Recalibration

To ensure accurate measurements, check the calibration of this instrument after each 1000 hours of operation or every six months if used infrequently. In addition, replacement of components may necessitate recalibration of the affected circuits. The calibration procedure can also be helpful in localizing certain troubles in the instrument. In some cases, minor troubles may be revealed and/or corrected by recalibration. Complete calibration instructions are given in the Calibration section. If only a partial calibration is performed, see the interaction chart, Table 6-1, for possible interactions with circuits not adjusted.

TROUBLESHOOTING

Introduction

The following information is provided to facilitate troubleshooting. Information contained in other sections of this manual should be used along with the following information to aid in locating the defective component. An understanding of the circuit operation is helpful in locating troubles, particularly where integrated circuits are used. See the Circuit Description section for this information.

Troubleshooting Aids

Troubleshooting Charts. As an aid in locating problem areas, troubleshooting charts have been provided for the low voltage power supplies, the —2450 volt power supply, and for a no visible display condition. These can be found on pullout pages in the Diagrams section.

Diagrams. Complete circuit diagrams are given on foldout pages in the Diagrams section. The portions of the circuit mounted on circuit boards are enclosed with grey lines. The component number and electrical value of each component in this instrument are shown on the diagrams (see the first page of the Diagrams section for definition of the reference designators used to identify components in this instrument). Each main circuit is assigned a series of component numbers to assist in identifying which circuit they are in. Important voltages and waveforms are also shown on the diagrams. The physical locations of the waveform test points are shown on the Circuit Board illustrations.

Circuit Board Illustrations. In conjunction with each circuit diagram is a circuit board illustration. These can be found on the back of the pullout page preceding the circuit diagram it relates to. Each circuit component shown on the circuit diagram is identified on the circuit board illustration by its component number. Each circuit board illustration is sectioned by a grid system. A table is provided listing all components on the circuit board illustration with their grid locations to facilitate rapid physical location of any component shown on the circuit diagrams.

Adjustment Locations Illustrations. To aid in locating test points and adjustable components, the adjustment locations pullout pages (normally used with the calibration procedure) permit very rapid location of test points and adjustments because only these components are identified.

Resistor Color-Code. In addition to the brown composition resistors, some metal-film resistors and some wire-wound resistors are used in the 465. The resistance values of wire-wound resistors are usually printed on the body of the component. The resistance values of composition resistors and metal-film resistors are color-coded on the components with EIA color-code (some metal-film resistors may have the value printed on the body). The color-code is read starting with the stripe nearest the end of the resistor. Composition resistors have four stripes which consist of two significant figures, a multiplier, and a tolerance value (see Fig. 4-2). Metal-film resistors have five stripes consisting of three significant figures, a multiplier, and a tolerance value.

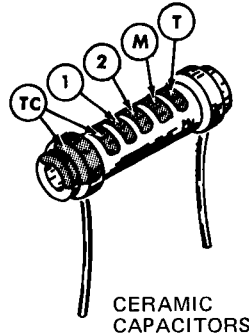
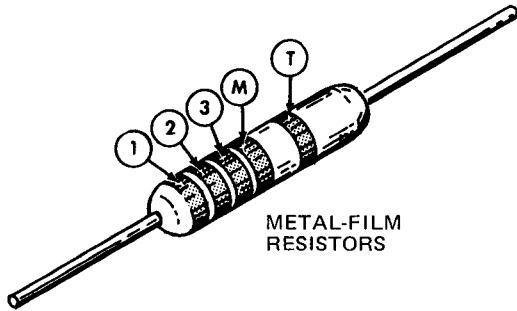
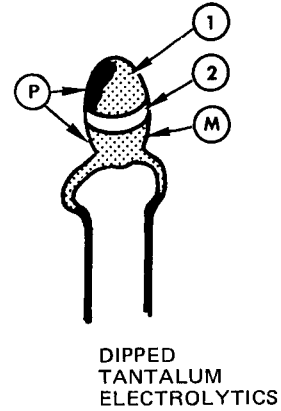
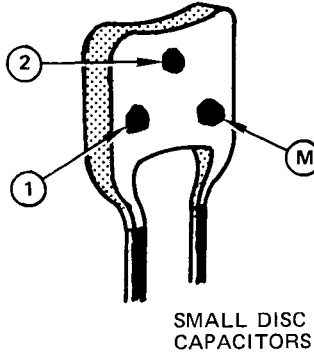
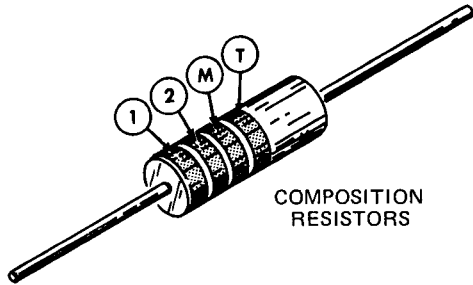

① ② and ③ — 1st, 2nd, and 3rd significant figures

Ⓜ — multiplier Ⓣ — tolerance

ⓉⓈ — temperature coefficient

Ⓟ — polarity and voltage rating

Ⓣ and/or ⓉⓈ color code may not be present on some capacitors

COLOR	SIGNIFICANT FIGURES	RESISTORS		CAPACITORS			DIPPED TANTALUM VOLTAGE RATING
		MULTIPLIER	TOLERANCE	MULTIPLIER	TOLERANCE		
					over 10 pF	under 10 pF	
BLACK	0	1	----	1	±20%	±2 pF	4 VDC
BROWN	1	10	±1%	10	±1%	±0.1 pF	6 VDC
RED	2	10 ² or 100	±2%	10 ² or 100	±2%	----	10 VDC
ORANGE	3	10 ³ or 1 K	±3%	10 ³ or 1000	±3%	----	15 VDC
YELLOW	4	10 ⁴ or 10 K	±4%	10 ⁴ or 10,000	+100% -9%	----	20 VDC
GREEN	5	10 ⁵ or 100 K	±½%	10 ⁵ or 100,000	±5%	±0.5 pF	25 VDC
BLUE	6	10 ⁶ or 1 M	±¼%	10 ⁶ or 1,000,000	----	----	35 VDC
VIOLET	7	----	±1/10%	----	----	----	50 VDC
GRAY	8	----	----	10 ⁻² or 0.01	+80% -20%	±0.25 pF	----
WHITE	9	----	----	10 ⁻¹ or 0.1	±10%	±1 pF	3 VDC
GOLD	—	10 ⁻¹ or 0.1	±5%	----	----	----	----
SILVER	—	10 ⁻² or 0.01	±10%	----	----	----	----
NONE	—	----	±20%	----	±10%	±1 pF	----

Fig. 4-2. Color codes.

Maintenance—465 Service (SN B250000 & up)

Capacitor Markings. The capacitance values of common disc capacitors and small electrolytics are marked on the side of the component body. The white ceramic capacitors used in the 465 are color-coded in picofarads, using a modified EIA code (see Fig. 4-2). The dipped tantalum capacitors used in the 465 are color-coded in microfarads (see Fig. 4-2). The color dot indicates the positive lead and voltage rating. Be careful to observe the polarity and voltage rating as they are easily destroyed by reverse or over voltage.

Diode Color-Code. The cathode end of each glass-encased diode is indicated by a stripe, a series of stripes, or a dot. For most silicone or germanium diodes with a series of stripes, the color-code identifies the three significant digits of the Tektronix Part Number using the resistor color-code system (e.g., a diode color-coded pink or blue-, brown - gray - green indicates Tektronix Part Number 152-0185-00). The cathode and anode ends of metal-encased diodes can be identified by the diode symbol marked on the body.

Semiconductor Lead Configurations. Typical semiconductor lead configurations are shown at the beginning of the diagrams section.

Troubleshooting Equipment

The following equipment is useful for troubleshooting.

1. Semiconductor Tester

Description: Dynamic-type tester. Must be capable of measuring reverse breakdown voltages of at least 400 volts.

Purpose: To test semiconductors.

Example: Tektronix 576 Curve Tracer or Tektronix 577 (D1 or D2) Curve Tracer with 177 Test Fixture.

2. Test Oscilloscope

Description: Frequency response, dc to at least 100 megahertz; deflection factor, 5 millivolts to 5 volts/division; Input impedance, 1 megohm, 20 picofarads; sweep rate, 0.5 second/division to 0.05 microsecond/division. A 10X, 10 megohm voltage probe should be used to reduce circuit loading for voltage measurements.

Purpose: To check operating waveforms.

Example: Tektronix 465 Oscilloscope with included 10X probe.

3. Multimeter

Description: Non-loading digital multimeter. Voltmeter, 10 megohm input impedance and 0 to 150 volts range; dc voltage accuracy, within 0.15%; display, 4 1/2 digits. Ohmmeter, 0 to 20 megohms.

Purpose: To check voltages and for general troubleshooting.

4. Variable Autotransformer

Description: Output variable from 0 to 140 volts, 1.2 amperes minimum rating. Must have a 3-wire power cord, plug and receptacle.

Purpose: To vary the input line voltage when troubleshooting in the power supply.

Example: General Radio W 8 MT 3 VM or W 10 MT 3 W Metered Variac Autotransformer.

Troubleshooting Techniques

This troubleshooting procedure is arranged in an order which checks the simple trouble possibilities before proceeding with extensive troubleshooting. The first few checks ensure proper connection, operation and calibration. If the trouble is not located by these checks, the remaining steps aid in locating the defective component. When the defective component is located, it should be replaced following the replacement procedure given under Corrective Maintenance.

1. Check Control Settings. Incorrect control settings can indicate a trouble that does not exist. If there is any question about the correct function or operation of any control, see the Operating Instructions section of this manual.

2. Check Associated Equipment. Before proceeding with troubleshooting, check that the equipment used with this instrument is operating correctly. Check that the signal is properly connected and that the interconnecting cables are not defective. Also, check the power source.

Maintenance—465 Service (SN B250000 & up)

3. Check Instrument Calibration. Check the calibration of this instrument, or the affected circuit if the trouble exists in one circuit. The apparent trouble may only be a result of misadjustment and may be corrected by calibration. Complete calibration instructions are given in the Calibration section of this manual.

4. Visual Check. Visually check the portion of the instrument in which the trouble is located. Many troubles can be located by visible indications such as unsoldered connections, broken wires, damaged circuit boards, damaged components, etc.

5. Isolate Trouble to a Circuit. To isolate trouble to a particular circuit, note the trouble symptom. The symptom often identifies the circuit in which the trouble is located. When trouble symptoms appear in more than one circuit, check the power supplies, then check the affected circuits. If the trouble has been isolated to a power supply follow the Troubleshooting Chart for that supply. The power supplies are interdependent. All the low voltage power supplies depend on +55 volts for reference. If more than one supply appears defective repair them in the following order:

- +55 Volt
- +110 Volt
- +15 Volt
- 8 Volt
- 2450 Volt

6. Check Circuit Board Interconnections. After the trouble has been isolated to a particular circuit, check for loose or broken connections, improperly seated transistors and heat damaged components.

7. Check Voltages and Waveforms. Often the defective component can be located by checking for the correct voltage or waveform in the circuit. Typical voltages are given on the diagrams. Waveforms are shown at the left of the circuit diagram.

NOTE

Voltages and waveforms given on the diagrams are not absolute and may vary slightly between instruments. To obtain operating conditions similar to those used to take these readings, see the voltage and waveform setup procedures at the beginning of

the Diagrams section. Exceptions to these procedures are noted with the readings to which they apply. Note the recommended test equipment, front panel control settings, voltage and waveform conditions and test equipment cable connection instructions. Voltages and waveforms given on the schematics should be checked against each instrument while it is operating properly. Deviations should be noted on the schematics for later reference.

8. Check Individual Components. The following procedures describe methods of checking individual components. Components which are soldered in place are best checked by disconnecting one end. This isolates the measurement from the effects of surrounding circuitry.

WARNING

The Power switch must be turned off before removing or replacing components.

A. Semiconductors. A good check of transistor operation is actual performance under operating conditions. A transistor can be most effectively checked by substituting a new component for it (or one which has been checked previously). However, be sure that circuit conditions are not such that a replacement transistor might also be damaged. If substitute transistors are not available, use a dynamic tester. Static-type testers are not recommended, since they do not check operation under simulated operating conditions.

When troubleshooting transistors in the circuit with a voltmeter, measure the emitter-to-base and emitter-to-collector voltages to determine if the voltages are consistent with normal circuit voltage. Voltages across a transistor vary with the type of device and its circuit function. Some of these voltages are predictable. The emitter-to-base voltage of a conducting silicone transistor will normally be 0.6 to 0.8 volts. The emitter-to-collector voltage of saturated transistors is approximately 0.2 volts. Because these values are small, the best way to check them is by connecting the voltmeter across the junction and using a sensitive voltmeter setting, rather than by comparing 2 voltages taken with respect to ground (both leads of the voltmeter must be isolated from ground if this method is used). If values less than these are obtained, either the device is short-circuited or no current is flowing in the circuit. If values are in excess of the base-emitter values given, the junction is back-biased or the

device is defective. Values in excess of those given for emitter-collector could indicate either a non-saturated device operating normally, or a defective (open-circuited) transistor. If the device is conducting, voltage will be developed across resistances in series with it; if it is open, no voltage will be developed across resistances in series with it unless current is being supplied by a parallel path.

When troubleshooting field-effect transistors, the voltage across its elements can be checked in the same manner as transistors. However, it should be remembered that normal depletion mode operation has the gate-to-source junction reverse biased, while the enhanced mode has the junction forward biased.

IC's (integrated circuits) can be checked with a voltmeter, test oscilloscope, or by direct substitution. A good understanding of circuit operation is essential to troubleshooting circuits using IC's. Use care when checking voltages and waveforms around the IC's so that adjacent leads are not shorted together. A convenient means of clipping a test probe to the 14- and 16-pin IC's is with an IC test clip. This device also doubles as an extraction tool. Typical semiconductor lead configurations are shown at the beginning of the Diagrams section.

B. Diodes. A diode can be checked for an open or for a short circuit by measuring the resistance between terminals with an ohmmeter set to the R X 1k scale. The diode resistance should be very high in one direction and very low when the meter leads are reversed. Do not check tunnel diodes or back diodes with an ohmmeter.

CAUTION

Do not use an ohmmeter scale that has a high internal current. High currents may damage the diode. Do not measure tunnel diodes with an ohmmeter; use a dynamic tester (such as a Tektronix Type 576 Transistor-Curve Tracer). Checks on diodes can be performed in much the same manner as on transistor emitter-to-base junctions. Silicon diodes should have 0.6 to 0.8 volts across the junction when conducting. Higher readings indicate that they are either back biased or defective, depending on polarity.

C. Resistors. Check the resistors with an ohmmeter. Check the Electrical Parts List for tolerance of the resistors used in this instrument. Resistors normally do not need to be replaced unless the measured value varies widely from the specified value.

D. Inductors. Check for open inductors by checking continuity with an ohmmeter. Shorted or partially shorted inductors can usually be found by checking the waveform response when high-frequency signals are passed through the circuit.

E. Capacitors. A leaky or shorted capacitor can best be detected by checking resistance with an ohmmeter on the highest scale. Do not exceed the voltage rating of the capacitor. The resistance reading should be high after initial charge of the capacitor. An open capacitor can be detected with a capacitance meter or by checking whether the capacitor passes ac signals.

F. Attenuators. The thick film attenuators are best checked by substitution. If only one channel of the 465 is not operating properly, and there is reason to believe an attenuator is defective, replace the suspected attenuator with the same attenuator from the other channel and check instrument operation. If proper operation results, order a new attenuator.

9. Repair and Readjust the Circuit. If any defective parts are located, follow the replacement procedures given in this section. Be sure to check the performance of any circuit that has been repaired or that has any electrical components replaced. Recalibration of the affected circuit may be necessary. Check Table 6-1 for possible adjustment interaction.

CORRECTIVE MAINTENANCE

Introduction

Corrective maintenance consists of component replacement and instrument repair. Special techniques required to replace components in this instrument are given here.

Obtaining Replacement Parts

Standard Parts. All electrical and mechanical part replacements for the 465 can be obtained through your local Tektronix Field Office or representative. However, many of the standard electronic components can be obtained locally in less time than is required to order them from Tektronix, Inc. Before purchasing or ordering replacement parts, check the parts list for value, tolerance, rating and description.

NOTE

Physical size and shape of a component may affect instrument performance, particularly at high frequencies. Always use direct-replacement components, unless it is known that a substitute will not degrade instrument performance.

Special Parts. In addition to the standard electronic components, some special components are used in the 465. These components are manufactured or selected by Tektronix, Inc. to meet specific performance requirements, or are manufactured for Tektronix, Inc. in accordance with our specifications (see Cross Index-Manufacturers Code Number to Manufacture in Electrical Parts List for code numbers). Most of the mechanical parts used in this instrument have been manufactured by Tektronix, Inc. Order all special parts directly from your local Tektronix Field Office or representative.

Ordering Parts. When ordering replacement parts from Tektronix, Inc., it is imperative that all of the following information be included in order to ensure receiving the proper parts.

1. Instrument type (include modification or option numbers).
2. Instrument serial number.
3. A description of the part (if electrical, include the circuit number).
4. Tektronix part number.

Soldering Techniques

WARNING

Always disconnect the instrument from the power source before attempting to solder in the instrument.

Ordinary 60/40 solder and 35- to 40-watt pencil-type soldering iron can be used to accomplish the majority of the soldering. If a higher wattage-rating soldering iron is used on the etched circuit boards, excessive heat can cause the etched circuit wiring to separate from the board base material.

CAUTION

The Vertical Preamplifier Attenuator circuit boards are made of material easily damaged by excessive heat. When soldering to these boards, do not use a soldering iron with a rating of more than approximately 15 watts. Avoid prolonged applications of heat to circuit-board connections. Use only isopropyl alcohol when cleaning this circuit board.

The following technique should be used to replace a component on the circuit board. Most components can be replaced without removing the boards from the instrument.

1. Grip the component lead with long-nose pliers. Touch the soldering iron to the lead at the solder connection. Do not lay the iron directly on the board, as it may damage the board.
2. When the solder begins to melt, pull the lead out gently. This should leave a clean hole in the board. If not, the hole can be cleaned by reheating the solder and placing a sharp object such as a toothpick into the hole to clean it out. A vacuum-type desoldering tool can also be used for this purpose.
3. Bend the leads of the new component to fit the holes in the board. If the component is replaced while the board is mounted in the instrument, cut the leads so they will just protrude through the board. Insert the leads into the holes in the board so the component is firmly seated against the board (or as positioned originally). If it does not seat properly, heat the solder and gently press the component into place.
4. Touch the iron to the connection and apply a small amount of solder to make a firm solder joint. To protect heat-sensitive components, hold the lead between the component body and the solder joint with a pair of long-nose pliers or other heat sink.
5. Clip the excess lead that protrudes through the board (if not clipped in step 3).
6. Clean the area around the solder connection with a flux-remover solvent. Be careful not to remove information printed on the board.

When soldering to the ceramic strips in the instrument a slightly larger soldering iron can be used. It is recommended that a solder containing about 3% silver be used when soldering to these strips to avoid destroying the bond to the ceramic material. This bond can be broken by repeated use of ordinary tin-lead solder or by the application of too much heat; however, occasional use of ordinary solder will not break the bond if excessive heat is not applied.

If it becomes necessary to solder in the general area of any of the high-frequency contacts in the instrument, clean the contacts immediately upon completion of the soldering. Refer to the section entitled Switch Contacts under Preventive Maintenance for recommended cleaners and procedures.

Component Removal and Replacement

WARNING

Always disconnect the instrument from the power source before attempting to replace components.

Circuit Boards. Occasionally it may be necessary to gain access to the reverse side of a circuit board or to remove one circuit board to gain access to another. The following procedures outline the necessary steps to facilitate instrument disassembly. Most of the connections to the circuit boards in the instrument are made with pin connectors. However, some connections are soldered to the board. Observe the soldering precautions given under Soldering Techniques in this section.

Vertical Preamp and Vertical Mode Switch Assembly. Remove and replace as follows:

1. Remove the instrument wrap-around cabinet in the manner given under Cabinet Removal at the beginning of this section.
2. Remove the knobs from the VOLTS/DIV switches and from the Input Coupling switches. The knobs on the VOLTS/DIV switches must have a set screw in each one loosened (use a 1/16" Allen wrench) before they can be removed, while the knobs on the Input Coupling switches are held on by spring clips and can be pulled off.

3. Disconnect the vertical POSITION control shaft couplers from the vertical POSITION potentiometers (0.050" Allen wrench required).

4. Remove the two uncal light lenses. Pry them away from the front panel with a fingernail and pull them straight out.

5. Disconnect the following cables and wires:

- a. Nine coaxial cables (5 on the front of the board and 4 on the back). Make note of cable color-codes to ensure proper installation during reassembly.

- b. Unplug P300 (an 8-wire ribbon cable) from the interface board.

- c. Unsolder the delay-line connections from the end of the Preamplifier board toward the back of the instrument.

- d. Locate the ground braid connecting the Preamplifier board to the Interface board near the INVERT switch shaft. Unsolder the end of the braid that connects to the Interface board (remove INVERT switch shaft if necessary to avoid burning it).

- e. Unsolder the +15 volt TRIG VIEW power wire where it connects to the Preamplifier board near Comp (Norm) Trig DC Bal potentiometer R340.

- f. Unplug P390 (an 8-wire ribbon cable) from the A4 Vertical Mode Switch board. Six of the P390 cable wires will remain connected to the scale-factor lamp assemblies that are attached to the front panel behind the VOLTS/DIV knob skirts. The wires from P390 pins 4 and 8 that actuate the X1 and X10 scale-factor indicator lamps (DS346 and DS392) must be unsoldered where they connect to the Preamplifier board. One wire connects to the front bottom corner of the board near the CH 2 input connector. The other wire connects to the center of the front edge of the board near the CH 1 input connector.

6. Remove the covers from the attenuators.

7. Unsolder the leads at each end of both input coupling capacitors. Remove the capacitors by unplugging their center body pins from the attenuator circuit boards.

8. Remove the 4 nuts securing the attenuator chassis to the instrument front casting (1/4" nutdriver required).

Maintenance—465 Service (SN B250000 & up)

9. Remove the circuit board hold-down screw on the Vertical Mode Switch circuit board (accessible through a hole in the Vertical Preamp circuit board near the Channel 1 POSITION potentiometer; Phillips screwdriver required).

10. Remove the 2 circuit board hold-down screws from the rear of the circuit board and the 3/16 inch post (with cabinet ground clip attached) from below the Channel 2 POSITION potentiometer. Use a 0.050" Allen wrench to loosen the set screw in the coupling for the TRIG VIEW/20 MHz BW switch shaft, and remove the shaft.

11. Remove the Vertical Preamp, cam switch assembly, and Vertical Mode Switch circuit board as a unit. Pull the rear of the Vertical Preamp circuit board outward about 1 or 2 inches; then slide the whole assembly to the rear until the front-panel control shafts clear the front casting.

To reinstall the Vertical Preamp and Vertical Mode Switch assembly, reverse the order of the removal steps. To align the VERT MODE switch pushbuttons, hold the assembly in place with a slight forward pressure and use some sort of small tool to reach through the front panel to align the buttons. Install the remaining parts by reversing the order of removal. Do not tighten the circuit board hold-down screws until the securing nuts at the front of the attenuator chassis are tight and the circuit board is aligned properly.

Trigger Generator and Sweep Logic Circuit Board. Remove and replace the Trigger circuit board as follows:

1. Remove the LOW LINE, READY, and TRIG light lenses from the front panel. Pry them away from the front panel with a fingernail and pull straight out.

2. Disconnect the following cables and wires:

a. Eight coaxial cables (5 on the front and 3 on the foil side of the board). Make note of cable color-codes to ensure proper installation during reassembly.

b. Two 5-wire ribbon cables from the Trigger and Level Controls to the Trigger and Sweep Logic circuit board (P530, P630).

c. The red and black wires and the ground braid from the back of the board near P5.

d. The 2 wires midway back on the foil side of the Trigger board near the 3/16" post.

e. The red wire near the front of the Trigger board near the 2 coaxial cables from the trigger view amplifier circuit.

3. Unsolder the 2 connections to the External Trigger Input connectors. Make note of wire color-codes to ensure proper installation during reassembly.

4. Remove the POWER switch actuator rod from the plastic holder on the switch. Pry the rod out of the holder with a small flat-bladed screwdriver and remove the rod from the instrument.

5. Remove the POWER switch bracket from the circuit board (3/16" wrench or nutdriver required).

6. Remove 5 mounting screws (Phillips screwdriver required) from the circuit board (2 at rear, 2 at front, and 1 in a post at top center near Q814. Also remove the post (3/16" nutdriver required).

7. Unplug the Trigger Generator and Sweep Logic circuit board from the Interface board by forcing the Trigger board away at the 2 white interboard connectors at the bottom edge of the Trigger board.

8. Move the Trigger board to the rear until the Trigger switches clear the front casting and then remove the assembly from the instrument. Exercise caution to avoid damaging the connector pins on the Interface board.

To reinstall the Trigger Generator and Sweep Logic circuit board, reverse the order of the removal steps. If the indexing of the Trigger switches was disturbed, a series of trial-and-error installation-removal-adjustment steps will be necessary to return them to correct alignment.

Sweep Timing Circuit Board. Remove and replace the Sweep Timing circuit board as follows:

1. Remove the Trigger Generator and Sweep Logic circuit board as described previously.

2. Unsolder three wires from the Timing circuit board. Make note of wire color-codes to ensure proper installation during reassembly.

3. Remove the VAR TIME/DIV, A TIME/DIV and B TIME/DIV knobs (1/16" and 5/64" Allen wrenches required). The VAR knob has one externally accessible Allen screw, and the large gray knob has two externally accessible Allen screws. The clear plastic skirt knob has two Allen screws which are accessible from behind the front panel casting.

4. Remove the X10 MAG and the UNCAL light lenses. Pry them away from the instrument front panel with a fingernail and pull straight out.

5. Unplug P1110 (plug and wires from DELAY TIME POSITION control) from J1110 on the Timing board.

6. Remove the board mounting screw and the hex rod from the Sweep Timing circuit board (Phillips screwdriver and 3/16" wrench or nutdriver required).

7. Use a flat blade screwdriver and pry the Timing board away from the Interface board. Gently pull away the corner of the Interface board near the B EXTERNAL TRIGGER INPUT connector and simultaneously lift up on the Timing board near the rear to fully disengage connector pins from the Interface board.

To reinstall the Timing board, reverse the order of the removal steps.

Power Transformer. If the power transformer becomes defective, be sure to replace only with a direct replacement Tektronix transformer. After the transformer is replaced, check the performance of the complete instrument. The transformer is removed as follows:

1. Unsolder the power cord from the Interface board, the Regulating Range Selector Assembly, and the solder lug on the rear subpanel.

2. Remove the small blue panel from the rear panel of the instrument (the short screw is at the top and the long screw is at the left side). It will be necessary to remove the rear ring assembly, as for cabinet removal (see Fig. 4-1) and the Regulating Range Selector cover to allow removal of the panel.

3. Disconnect the actuating shaft from the POWER switch coupler and remove the shaft from the instrument. Be careful not to damage the switch coupler.

4. Remove the POWER switch mounting bracket from the Trigger board (3/16" wrench or nutdriver required).

5. Unsolder the transformer leads from the Interface board and the solder lug on the rear subpanel. Note the wire color-codes to facilitate correct re-installation.

6. Remove the transformer leads from the Regulating Range Selector Assembly. It will be necessary to use a

special pin removing tool available from Tektronix, Inc. Order Tektronix Part Number 003-0707-00. It is only necessary to use this tool to remove the transformer leads from the Selector Assembly. The leads may be re-installed by simply pushing them into place. Note wire color codes to facilitate correct re-installation.

7. Remove the transformer bracket mounting hardware. This includes two screws on the Trigger board, 1 screw on the Interface board, 2 nuts on the U-channel (1 on the transformer side and 1 on the crt side), and 2 screws and nuts on the rear subpanel.

8. Thoroughly loosen the Trigger board, then lift the transformer assembly partially out until the thermal cutoff retaining screws can be removed. Remove these retaining screws with a Phillips screwdriver and lift the transformer assembly out of the instrument.

9. Remove the thermal cutout and POWER switch from the old transformer and install on the new transformer. Note wire color-codes to facilitate correct installation.

10. Install the new transformer assembly in the instrument reversing the order of the removal steps.

Cathode Ray Tube (crt). Remove and replace the crt as follows:

WARNING

Handle the crt carefully. Rough handling or scratching can cause the crt to implode.

1. Remove the plastic bezel and filter from the front of the crt (held with 4 screws).

2. Remove the feet from the rear of the instrument (held on by 1 screw in each foot accessible through a hole in that foot).

3. Remove the rear ring (held by 2 screws).

4. Remove the rear cover (held by 2 flat head screws).

5. Remove the bell-shaped cover to expose the crt socket (held by 2 screws).

6. Unplug the crt socket.

Maintenance—465 Service (SN B250000 & up)

7. Remove the 2 vertical deflection pins from the left side of the crt neck.

8. Set the instrument on its left side (Vertical Preamp board side).

9. Remove the horizontal deflection pin connectors from the bottom of the crt neck (accessible through a hole in the Interface board).

10. Position the instrument so the top is accessible.

11. Locate the anode lead connector that is held in place by a metal clip fastened to the chassis. Pull the top portion of the anode lead out of the connector (where the connector plugs together just above the metal clip) and discharge the metal tip to the chassis.

12. Holding one hand on the crt face, push slowly on the crt base with the other hand. Guide the anode connector through the crt shield while slowly pulling the crt out of the instrument. The plastic corner pads may fall out during removal; save them for reinstallation.

13. Reverse the above procedure to install a crt. Observe the following precautions:

a. Be sure to guide the anode lead through the hole in the crt shield while pushing the crt into the instrument.

b. Be sure the plastic corner pads are securely seated.

c. Be sure the plastic centering ring firmly centers the crt neck. Reposition the ring as necessary.

High Voltage Multiplier. Remove and replace the High Voltage Multiplier as follows:

1. Remove the Vertical Preamp board and crt as described previously.

2. Slide the round part of the crt shield to the rear about 2 inches.

3. Remove the high voltage shield (held on by four screws). Note the position of the cabinet grounding clip for reassembly reference.

4. Remove the four 3/16 inch studs to which the high voltage shield is secured.

5. Remove the mounting screw from Q1566 and Q1534 at the rear of the Interface board.

6. Remove the circuit board hold-down screw just forward of P1446 on the Interface board.

7. Remove the shield from the high voltage transformer and high voltage multiplier (one piece held by 3 screws).

8. Unsolder the black wire (between the High Voltage Multiplier and the Interface board) from the Interface board.

9. Unsolder the diode and the wire from the post on the High Voltage Multiplier.

10. Remove the 2 nylon nuts securing the High Voltage Multiplier to the Interface board.

11. Remove the High Voltage Multiplier (carefully pry up on the Interface board as necessary to facilitate removal).

12. Reverse the above procedure to install the High Voltage Multiplier.

Transistors and Integrated Circuits. Transistors and ICs (integrated circuits) should not be replaced unless they are actually defective. If removed from their sockets during routine maintenance, return them to their original sockets. Unnecessary replacement or switching of semiconductor devices may affect the calibration of the instrument. When a transistor is replaced, check the operation of the part of the instrument that may be affected.

Any replacement component should be of the original type or a direct replacement. Bend the leads to fit the socket and cut the leads to the same length as on the component being replaced. See Fig. 8-1 for basing diagrams.

An extracting tool should be used to remove the 14, 16, and 20 pin integrated circuits to prevent damage to the pins. This tool is available from Tektronix, Inc. Order Tektronix Part Number 003-0619-00. If an extracting tool is not available when removing one of these integrated circuits, pull slowly and evenly on both ends on the device. Try to avoid having one end of the integrated circuit disengage from the socket before the other, since this may damage the pins.

WARNING

Handle silicone grease with care. Avoid getting silicone grease in the eyes. Wash hands thoroughly after use.

WARNING

Voltages are present on the exterior surface of the chassis-mounted power supply transistors if the power is applied to the instrument and the POWER switch is on.

The chassis-mounted power supply transistors and their mounting bolts are insulated from the chassis. In addition, silicone grease is used to increase heat transfer capabilities. Re-install the insulators and replace the silicone grease when replacing these transistors. The grease should be applied to both sides of the mica insulators, and should be applied to the bottom side of the transistor where it comes in contact with the insulator.

NOTE

After replacing a power transistor, check that the collector is not shorted to ground before applying power.

Interconnecting Pins. Two methods of interconnection are used in this instrument to connect the circuit boards with other boards and components. When the interconnection is made with a coaxial cable, a special end-lead connector plugs into a socket on the board. Other interconnections are made with a pin soldered onto the board. Two types of mating connections are used for these interconnecting pins. If the mating connector is on the end of a lead, an end-lead pin connector is used which mates with the interconnecting pin. The following information provides the replacement procedure for the various types of interconnecting methods:

a. Coaxial-Type End-Lead Connectors. Replacement of the coaxial-type end-lead connectors requires special tools and techniques; only experienced maintenance personnel should attempt replacement of these connectors. It is recommended that the cable or wiring harness be replaced as a unit. For cable or wiring harness part numbers, see the Mechanical Parts List. An alternative solution is to refer the replacement of the defective connector to your local Tektronix Field Office or representative.

NOTE

A circuit-board pin replacement kit including necessary tools, instructions, and replacement pins is available from Tektronix, Inc. Order Tektronix Part Number 040-0542-00.

b. Circuit Board Pins. To replace a pin which is mounted on a circuit board, first disconnect any pin connectors. Then, unsolder the damaged pin and pull it out of the circuit board with a pair of pliers. Be careful not to damage the wiring on the board with too much heat. Ream out the hole in the circuit board with a 0.031-inch drill. Remove the ferrule from the new interconnecting pin and press the new pin into the hole in the circuit board. Position the pin in the same manner as the old pin. Then solder the pin on both sides of the circuit board. If the old pin was bent at an angle to mate with a connector, bend the new pin to match the associated pins.

c. Circuit Board Pin Sockets. The pin sockets on the circuit boards are soldered to the rear of the board. To replace one of these sockets, first unsolder the pin (use a vacuum-type desoldering tool to remove excess solder). Then straighten the tabs on the socket and remove it from the hole in the board. Place the new socket in the circuit board hole and press the tabs down against the board. Solder the tabs of the socket to the circuit board; be careful not to get solder into the socket.

NOTE

The spring tension of the pin sockets ensures a good connection between the circuit board and the pin. This spring tension can be destroyed by using the pin sockets set as a connecting point for spring-loaded probe tips, alligator clips, etc.

d. End-Lead Pin Connectors. The pin connectors used to connect the wires to the interconnecting pins are factory assembled. They consist of machine installed pin connectors mounted in plastic holders. The plastic holders are easily replaced as individual items; but if the connectors are faulty, the entire cable assembly should be replaced. Individual pin connectors are listed in the parts list, but special tools are required for installation.

When pin connectors are grouped together and mounted in a plastic holder, these connectors are removed and installed as a multi-pin connector. To provide correct orientation of this multi-pin connector when it is replaced, an arrow is stamped on the circuit board and a matching arrow is molded into the plastic housing of the multi-pin connector. Be sure these arrows are aligned as the multi-pin connector is reinstalled. If the individual end-lead pin connectors are removed from the plastic holder, note the color of the individual wires for replacement.

Ceramic Terminal Strips. Replacement strips (including studs) and spacers are supplied under separate part numbers. However, the old spacers may be re-used if

Maintenance—465 Service (SN B250000 & up)

they are not damaged. The applicable Tektronix Part Numbers for the ceramic strips and spacers used in this instrument are given in the Mechanical Parts List.

Remove ceramic terminal strips as follows:

1. Unsolder all components and connections on the strip. To aid in replacing the strip, it may be advisable to mark each lead or draw a sketch to show location of the components and connections.

2. Pry or pull the damaged strip from the chassis.

3. If the spacers come out with the strip, remove them from the stud pins for use on the new strip (spacers should be replaced if they are damaged).

Replace ceramic terminal strips as follows:

1. Place the spacers in the chassis holes.

2. Carefully press the studs of the strip into the spacers until they are completely seated.

3. If the stud extends through the spacers, cut off the excess.

4. Replace all components and connections. Observe the soldering precautions under Soldering Techniques in this section.

Recalibration After Repair

After any electrical component has been replaced, the calibration of that particular circuit should be checked, as well as the calibration of other closely related circuits.

Since the power supply affects all circuits, calibration of the entire instrument should be checked if work has been done in the power supply or if the transformer has been replaced.

Instrument Repackaging

If the Tektronix instrument is to be shipped to a Tektronix Service Center for service or repair, attach a tag showing: owner (with address) and the name of an individual at your firm that can be contacted, complete instrument serial number, and a description of the service required.

Save and re-use the package in which your instrument was shipped. If the original packaging is unfit for use or not available, repackage the instrument as follows:

1. Obtain a carton of corrugated cardboard having inside dimensions of no less than six inches more than the instrument dimensions; this will allow for cushioning. Refer to the following table for carton test strength requirements.

2. Surround the instrument with polyethylene sheeting to protect the finish of the instrument.

3. Cushion the instrument on all sides by tightly packing dunnage or urethane foam between carton and instrument, allowing three inches on all sides.

4. Seal carton with shipping tape or industrial stapler.

SHIPPING CARTON TEST STRENGTH

Gross Weight (lb)	Carton Test Strength (lb)
0—10	200
10—30	275
30—120	375
120—140	500
140—160	600

RACKMOUNTING

Introduction

The TEKTRONIX R465 Oscilloscope is designed to mount in a 19-inch rack. When mounted in accordance with the following mounting procedure, the instrument will meet all electrical and environmental characteristics given in Section 1.

Instrument Dimensions

A dimensional drawing showing the major dimensions of the R465 is shown in Fig. 4-13.

Rack Dimensions

Height. At least seven inches of vertical space is required to mount this instrument in a rack.

Width. Minimum width of the opening between the left and right front rails of the rack must be 17 5/8 inches. This allows room on each side of the instrument for the slide-out tracks to operate freely, permitting the instrument to move smoothly in and out of the rack.

Depth. Total depth necessary to mount the R465 in a cabinet is 18 inches. This allows room for air circulation, power cord and signal connections and the necessary mounting hardware.

Slide-Out Tracks

The slide-out tracks provided with the R465 permit it to be extended out of the rack for maintenance or calibration without removing the instrument from the rack. In the fully extended position, the R465 can be tilted up so the bottom of the instrument can be reached for maintenance or calibration. To operate the R465 in the extended position, be sure the power cord and any interconnecting cables are long enough for this purpose.

The slide-out tracks consist of two assemblies—one for the left side of the instrument and one for the right side. Fig. 4-3 shows the complete slide-out track assemblies. The stationary section of each assembly attaches to the front and rear rails of the rack, and the chassis section is attached to the instrument. The intermediate section slides between the stationary and chassis sections and allows the R465 to be extended out of the rack. When the instrument is shipped, the stationary and intermediate sections of the tracks are packaged as matched sets and should not be separated. To identify the left or right assembly, note the position of the automatic latch (see Fig. 4-3). When mounted in the rack, the automatic latch

Maintenance—465 Service (SN B250000 & up)

should be at the top of both assemblies. The chassis sections are installed on the instrument at the factory.

The hardware needed to mount the slide-out tracks is shown in Fig. 4-4. Since the hardware supplied is intended to make the tracks compatible with a variety of cabinet racks and installation methods, not all of it will be needed for this installation. Use only the hardware that is required for the mounting method used.

Mounting Procedure

The following mounting procedure uses the rear support kit (see Figs. 4-8 and 4-9) to meet the environmental characteristics of the instrument (shock and vibration). Two alternative mounting methods are described at the end of this procedure. However, when mounted according to these alternative methods, the instrument may not meet the given environmental characteristics for shock and vibration.

The mounting flanges of the stationary sections may be mounted in front of or behind the front rails of the rack depending on the type of rack. If the front rails of the rack are tapped for 10-32 screws, the mounting flanges are placed in front of the rails. If the front rails of the rack are not tapped for 10-32 screws, the mounting flanges are placed behind the front rail and a bar nut is used. Fig. 4-7 shows these methods of mounting the stationary sections.

The rear of the stationary sections must be firmly supported to provide a shock-mounted installation. This rear support must be located 17.471 inches, ± 0.031 inch, from the outside surface of the front rail when the mounting flange is mounted outside of the rail, or 17.531 inches, ± 0.031 inch, from the rear surface of the front rail when the mounting flange is mounted behind the front rail. If the cabinet rack does not have a strong supporting member located the correct distance from the front rail, an additional support must be added. The instrument will not meet the environmental specifications unless firmly supported at this point. Fig. 4-7 illustrates a typical rear installation using the rear support kit and gives the necessary dimensions.

Use the following procedure to install the R465 in a rack:

1. Select the proper front-rail mounting holes for the stationary section using the measurements shown in Fig. 4-7.

- 2a. If the mounting flanges of the stationary sections are to be mounted in front of the front rails (rails tapped for 10-32 screws), mount each stationary section as shown in Fig. 4-6A.

Maintenance—465 Service (SN B250000 & up)

2b. If the mounting flanges of the stationary sections are to be mounted behind the front rails (rails not tapped for 10-32 screws), mount each stationary section as shown in Fig. 4-6B.

3. Attach an angle bracket to both rear rails of the rack through the spacer block, stationary section and into the rear rail of the rack. Note that the holes in the spacer block are not centered. Be sure to mount the block with the narrow edge toward the front of the rack; otherwise, the instrument may not slide all the way into the rack. Do not tighten the mounting screws. Fig. 4-8 shows the parts in the rear support kit and the order in which they are assembled.

4. Assemble the support pin to the angle bracket in the order shown in Fig. 4-8. Leave the spacer (washer) off, but install the neoprene washer.

5. Install a support block on each side of the instrument as shown in Fig. 4-9.

6. Refer to Fig. 4-10 to insert the instrument in the rack. Do not connect the power cord or install the securing screws until all adjustments have been made.

7. With the instruments pushed all the way into the rack, adjust the angle brackets so the neoprene washers on the support pins are seated firmly against the rear of the instrument and the support pins are correctly positioned in the support block on the rear of the instrument. Tighten all screws.

8. Pull the instrument partially out of the rack.

9. Remove the neoprene washers from the support pins and place the spacers on the pins. Replace the neoprene washers.

10. Position the instrument so the pivot screws (widest part of the instrument) are approximately even with the front rails.

11. Adjust the alignment of the stationary sections according to the procedure outlined in Fig. 4-11. (If the rear alignment is changed, recheck the rear support pins for correct alignment.)

12. After the tracks operate smoothly, connect the power cord to the power source.

13. Push the instrument all the way into the rack and secure it to the rack with the securing screws and washers as shown in Fig. 4-10.

NOTE

The securing screws are an important part of the shock-mounted installation. If the front rails are not tapped for the 10-32 securing screws, other means must be provided for securing the instrument to the rack.

Alternative Rear Mounting Methods

CAUTION

Although the following methods provide satisfactory mounting under normal conditions, they do not provide solid support at the rear of the instrument. If the instrument is subjected to severe shock or vibration when mounted using the following methods, it may be damaged.

An alternative method of supporting the rear of the instrument is shown in Fig. 4-12. The rear support brackets supplied with the instrument allow it to be mounted in a rack which has a spacing between the front and rear rails of 11 to 24 inches. Fig. 4-12A illustrates the mounting method if the rear rails are tapped for 10-32 screws, and Fig. 4-12B illustrates the mounting method if the rear rails are not tapped for 10-32 screws. The rear support kit is not used for this installation.

If the rack does not have a rear rail, or if the distance between the front and rear rails is too large, the instrument may be mounted without the use of the slide-out tracks. Fasten the instrument to the front rails of the rack with the securing screws and washers. This mounting method should be used only if the instrument will not be subjected to shock or vibration and if it is installed in a stationary location.

Removing or Installing the Instrument

After initial installation and adjustment of the slide-out tracks, the R465 can be removed or installed by following the instructions given in Fig. 4-10. No further adjustments are required under normal conditions.

Slide-Out Track Lubrication

The slide-out tracks normally require no lubrication. The special finish on the sliding surfaces provides permanent lubrication. However, if the tracks do not slide smoothly even after proper adjustment, a thin coating of paraffin rubbed onto the sliding surfaces may improve operation.

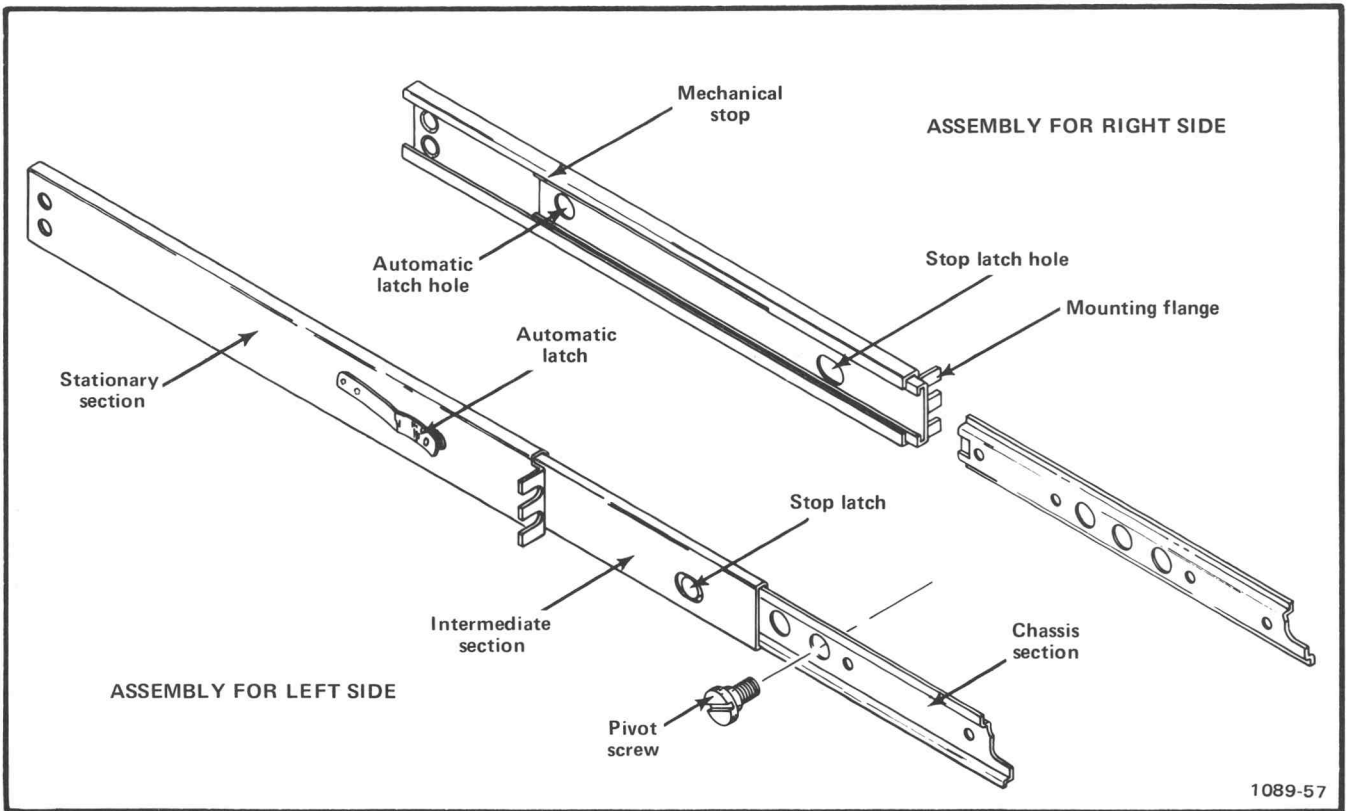

Fig. 4-3. Slide-out track assemblies.

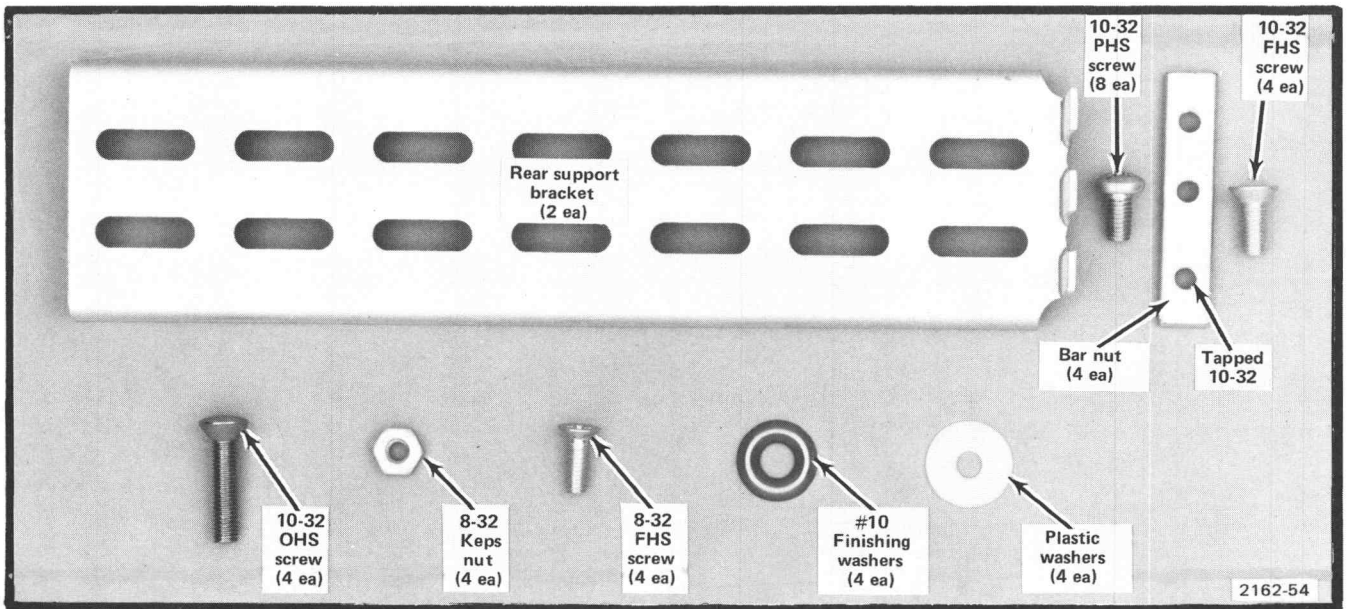

Fig. 4-4. Hardware needed to mount the instrument in the cabinet rack.

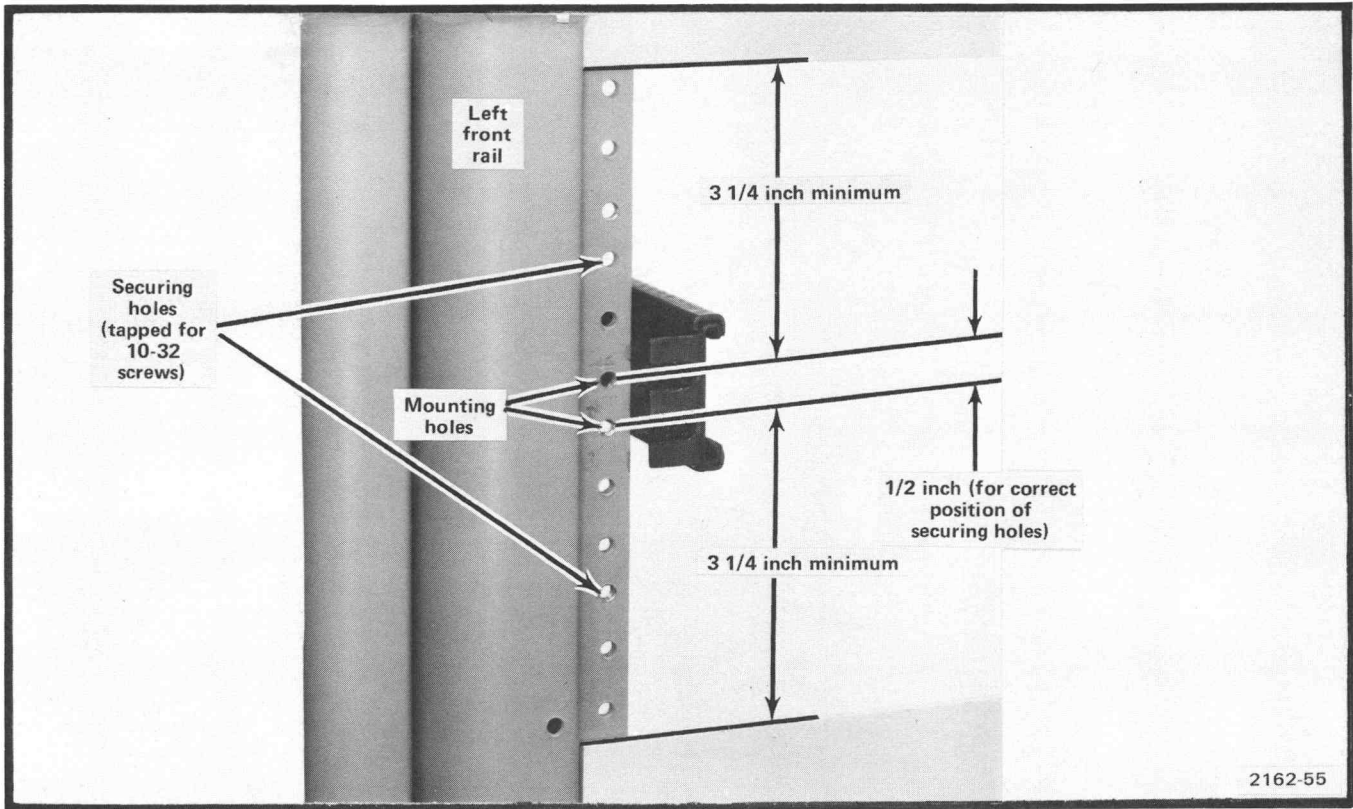

Fig. 4-5. Locating the mounting holes for the left stationary section. Same dimensions apply to right stationary section.

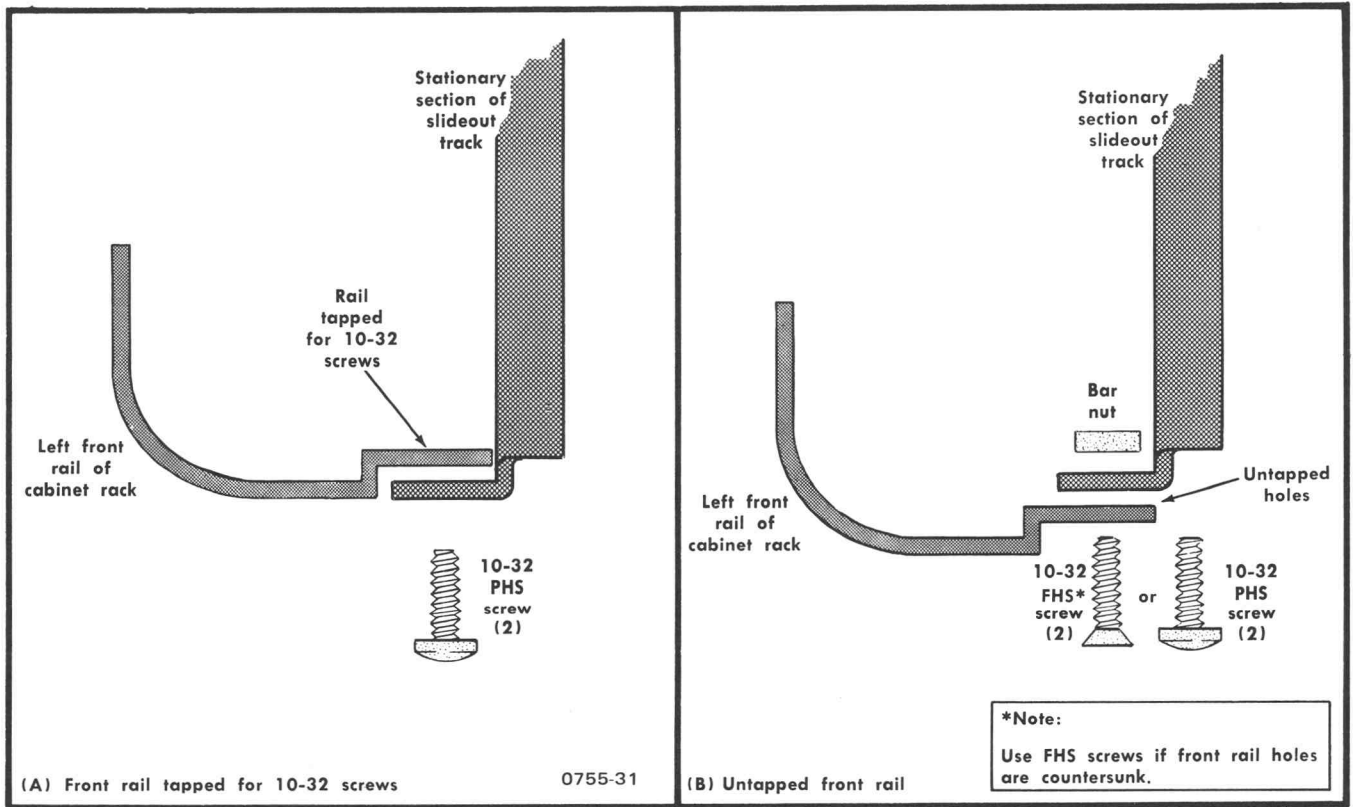

Fig. 4-6. Methods of mounting the stationary section to the front rails.

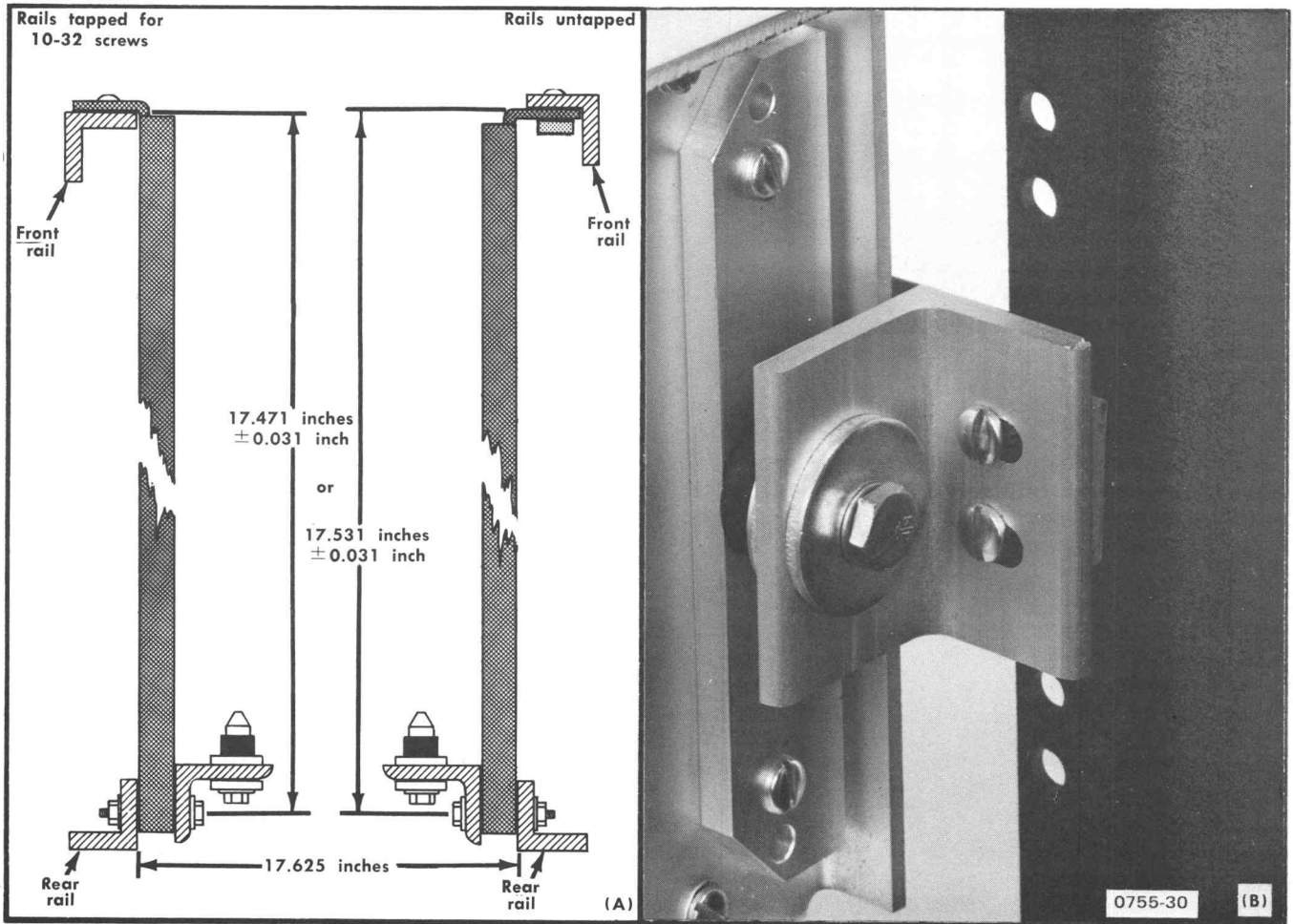

Fig. 4-7. Supporting the rear of the stationary sections: (A) Dimensions necessary; (B) Completed installation.

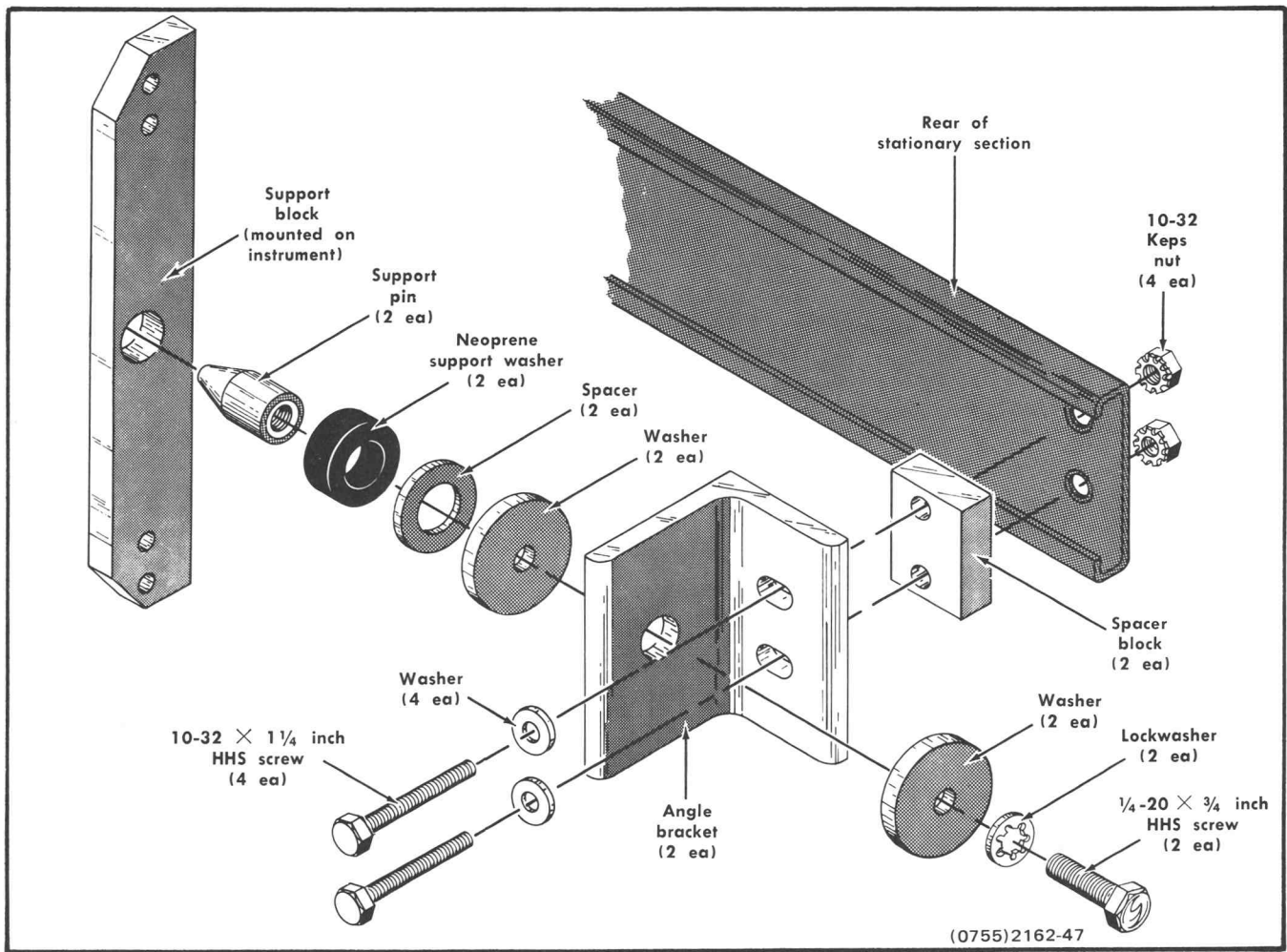

Fig. 4-8. Rear Support kit.

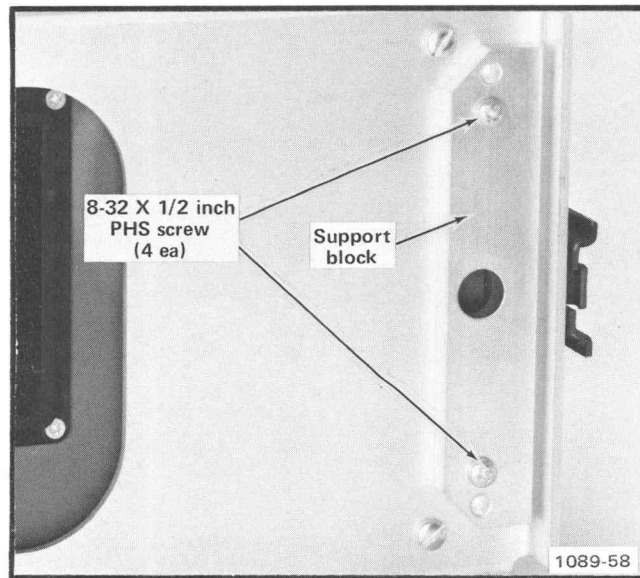
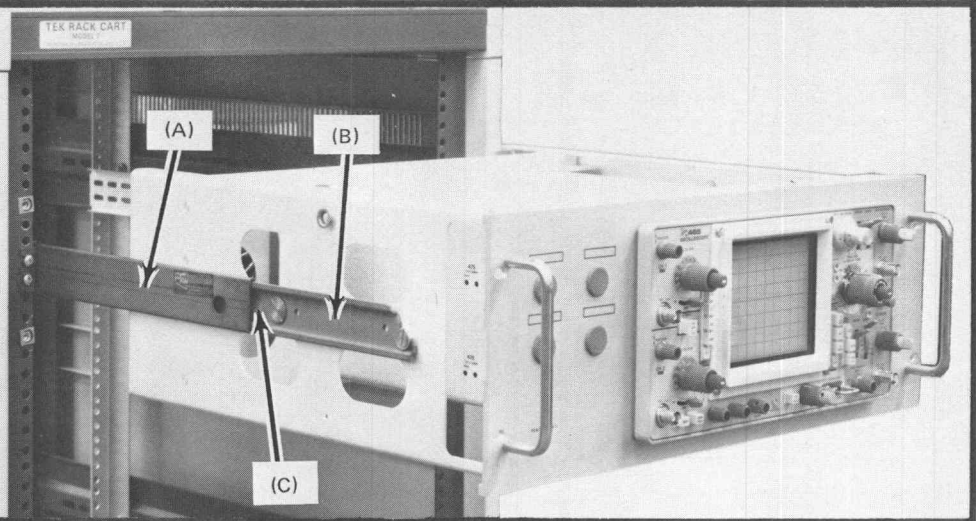

Fig. 4-9. Installing the support block on the instrument.

TO INSERT THE R465:

1. Pull the intermediate section (A) of each slide-out track out to its fully extended position.
2. Insert the chassis section (B) (on instrument) into the intermediate sections.
3. Press both stop latches (C) and push the instrument into the rack until the latches snap into the stop latch holes (D).



4. Connect the power cord to the power source.
5. Again press the stop latches (D) and push the instrument all the way into the rack.
6. To secure the R465 to the rack, insert the 4 securing screws (E), with finishing washers and teflon washers, through the slots in the instrument front panel and screw them into the front rails of the rack.

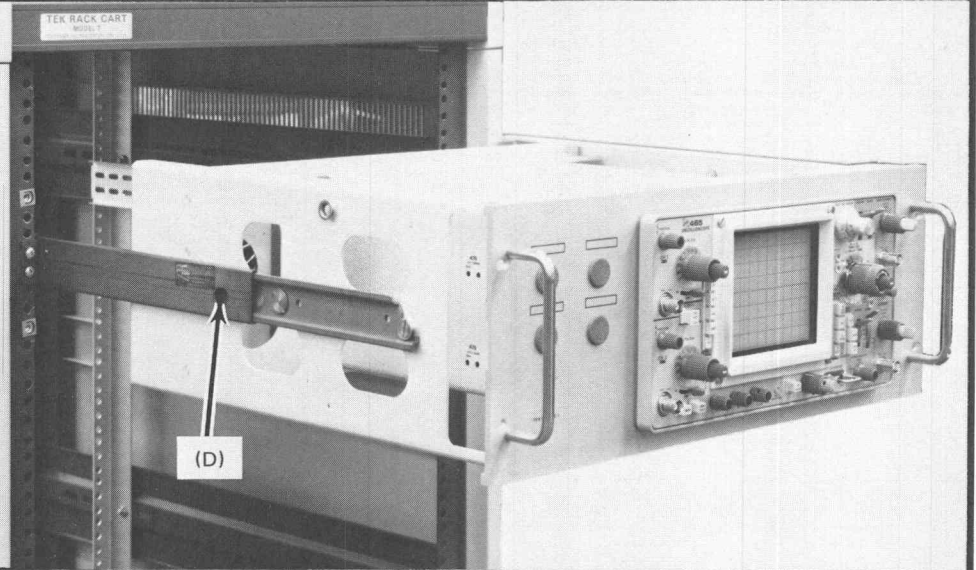

TO REMOVE THE R465:

1. Remove the securing screws and washers (E).
2. Pull the instrument outward until the stop latches snap into the stop latch holes.
3. Disconnect the power cord.
4. Press both stop latches (D) and pull the instrument out of the rack.

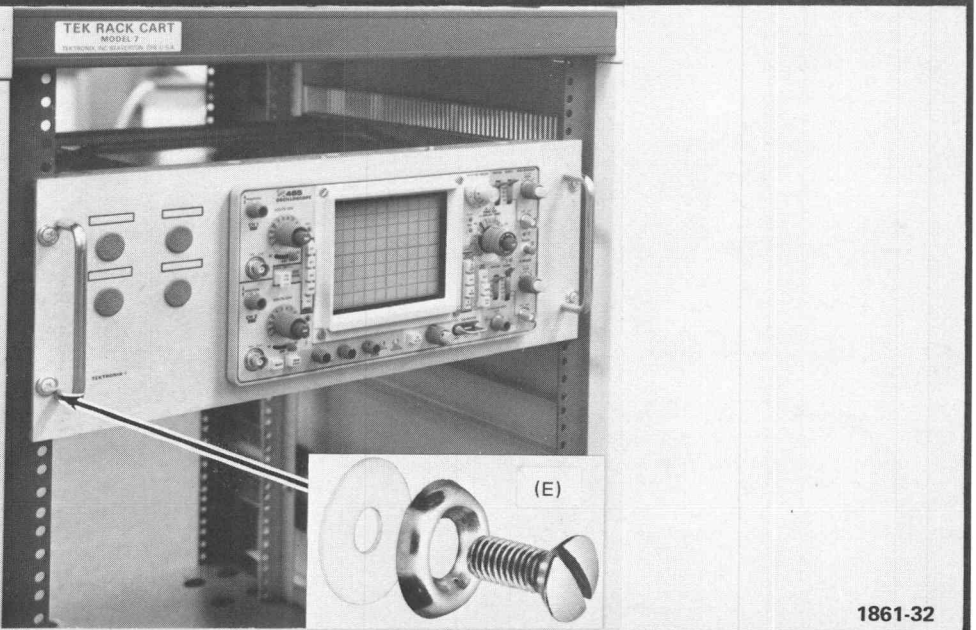

1861-32

Fig. 4-10. Procedure for inserting or removing the instrument after the slide-out tracks have been installed.

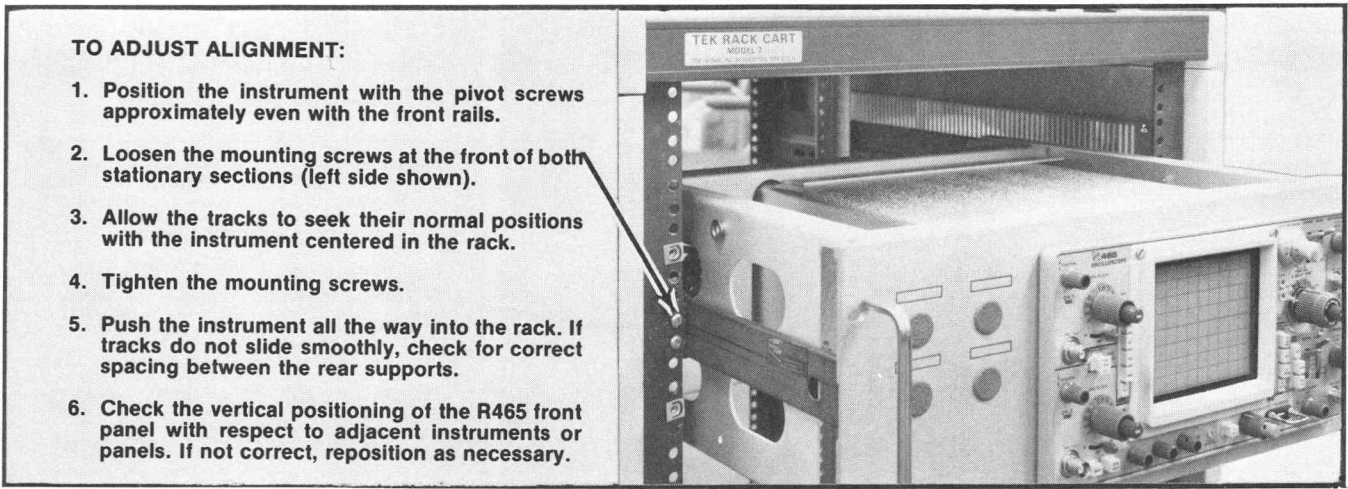

Fig. 4-11. Alignment adjustments for correct operation.

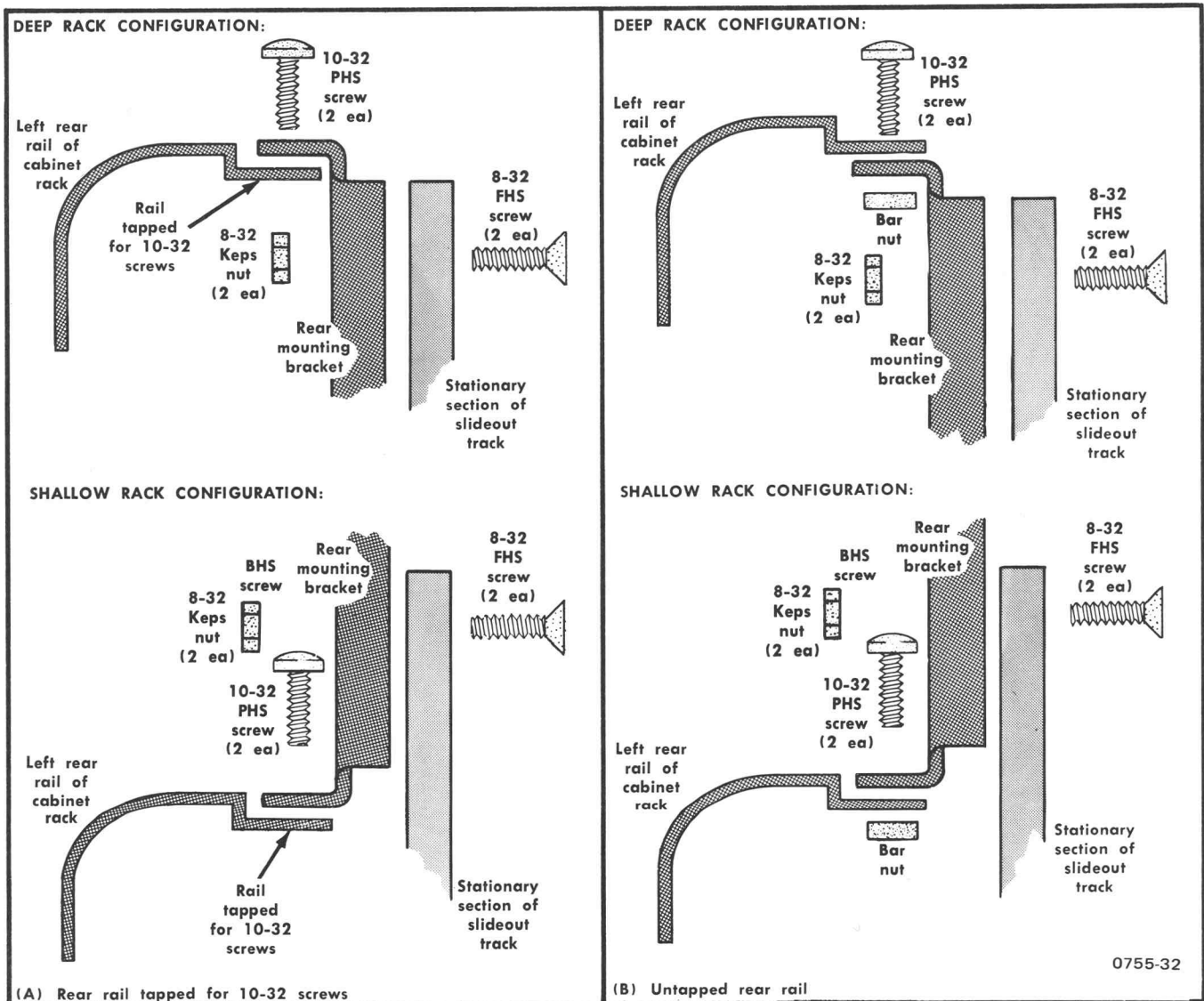
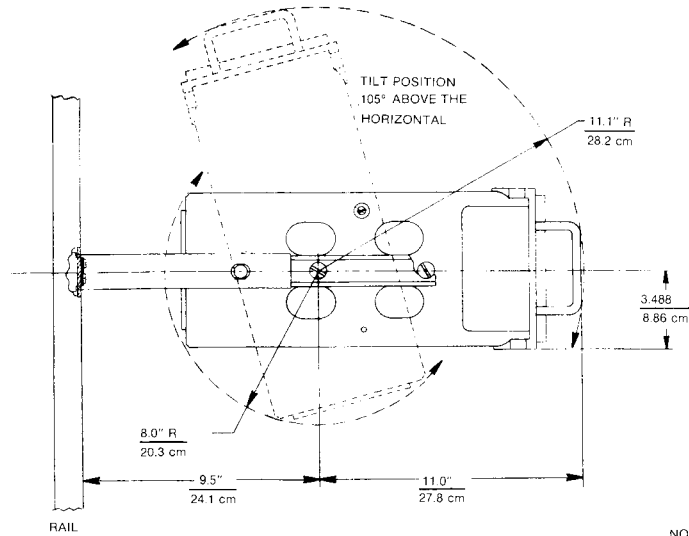
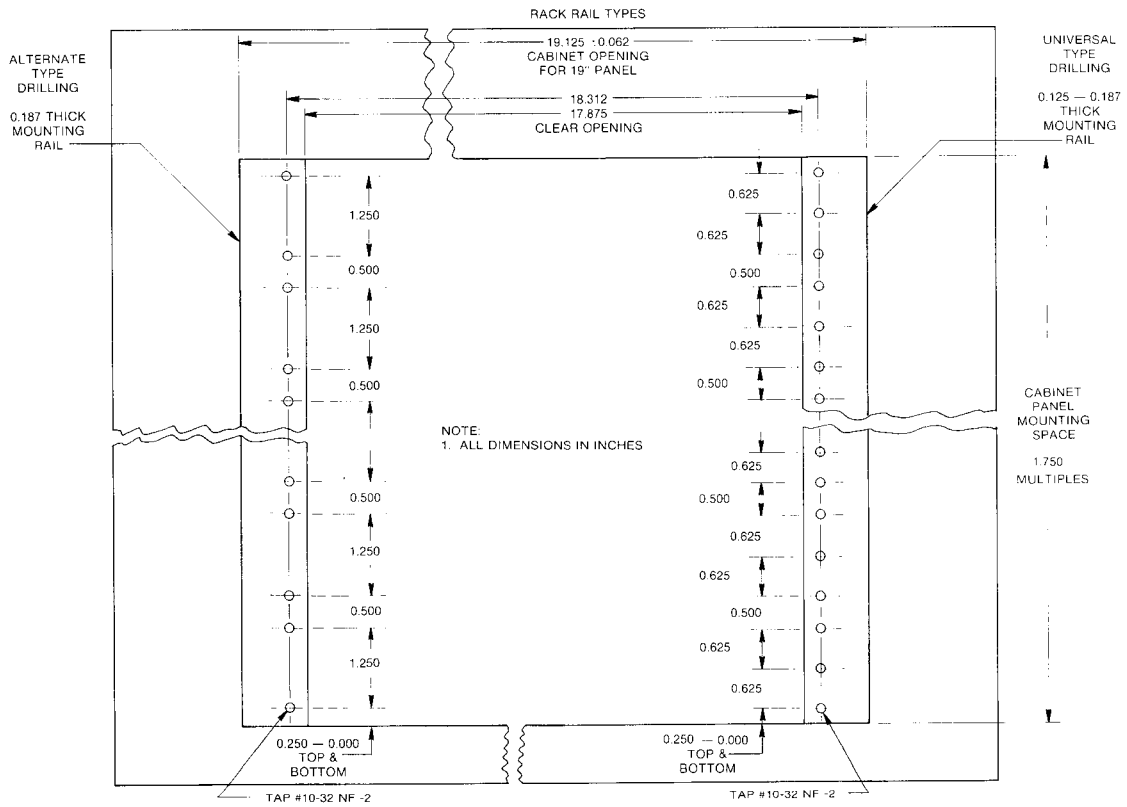

Fig. 4-12. Alternative method of installing the instrument using rear support brackets.



NOTES:
1. ALL DIMENSIONS ARE REFERENCE DIMENSIONS EXCEPT AS NOTED



2162-51

Fig. 4-13. Dimensional Drawing.

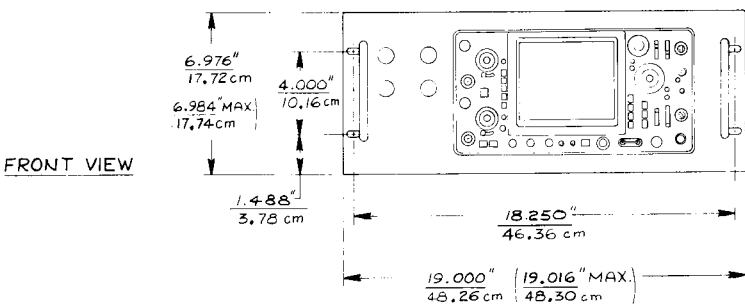
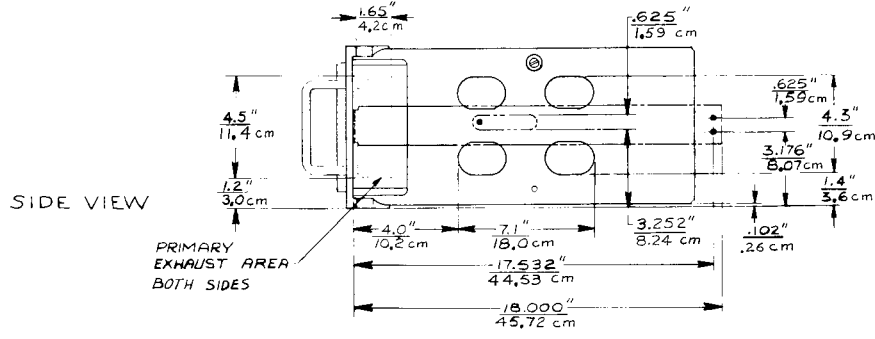
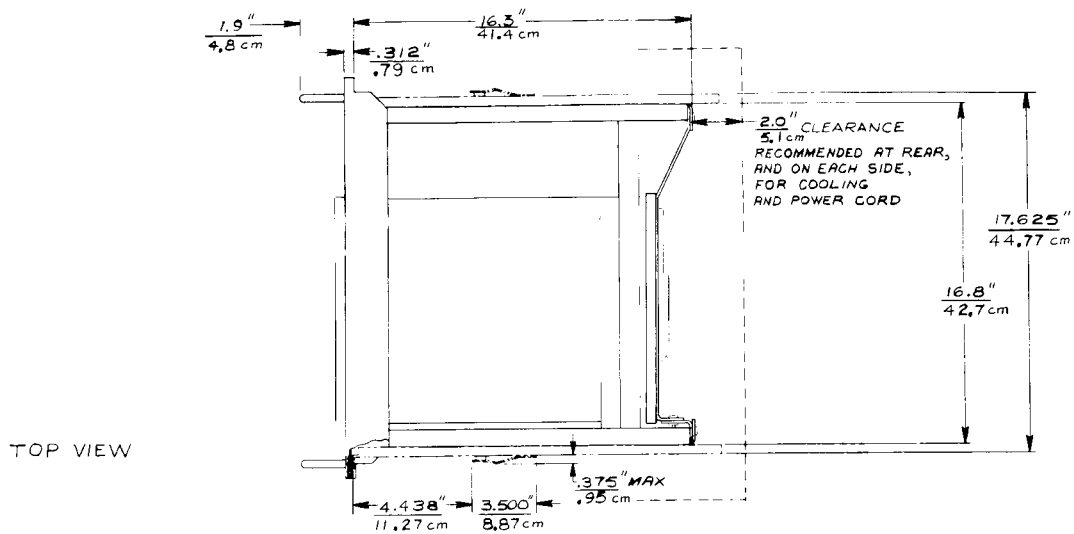

NOTE:
1. ALL DIMENSIONS ARE REFERENCE ONLY UNLESS OTHERWISE NOTED.

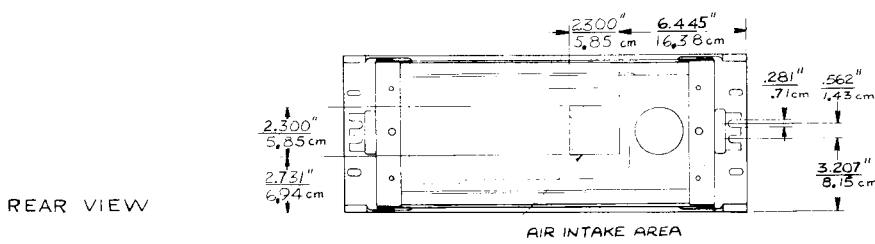

Fig. 4-13. Dimensional Drawing (cont).

PERFORMANCE CHECK

Purpose

The following procedure is intended to be used for incoming inspection to determine the acceptability of newly purchased or recently recalibrated instruments. This procedure does not check every facet of the instrument's calibration; rather it is concerned primarily with those portions of the instrument that are essential to measurement accuracy and correct operation. Removing the instrument's dust cover is not necessary to perform this procedure. All checks are made from the front panel.

NOTE

If a complete check of every facet of the instrument's operation is desired, perform the calibration procedure eliminating the ADJUST portion of the Check/Adjust steps.

Limits and Tolerances

All limits and tolerances given in this procedure are performance guides and should not be interpreted as specifications unless they are found in the specifications section of this manual.

Line Voltage Selection

This procedure is for 115 V ac line, medium range. If a different range is to be used, set the Regulating Range Selector and Line Voltage Selector for the available line voltage (see Item 42 under controls and connectors in section 2).

Equipment Required

The following equipment is required to perform a complete Performance Check. For equipment specifications, usage, and recommended types see Table 6-2 in the Calibration section.

1. Amplitude Calibrator
2. Square-wave Generator
3. Leveled Sine-wave Generator
4. Time-mark Generator
5. 42 Inch, 50-ohm BNC Cable (2 Required)
6. Dual Input Coupler (2 Required)
7. GR-to-BNC-Female Adapter
8. GR-to-BNC-Male Adapter

9. 10X BNC Attenuator
10. 2X BNC Attenuator
11. 50-ohm BNC Termination (2 Required)
12. 20-picofarad RC Input Normalizer
13. 50-ohm Signal Pickoff Unit (Type CT-3)
12. 50-ohm Signal Pickoff Unit (Type CT-3)

Special Fixtures

Special fixtures are used only where they simplify the test setup and procedure. These fixtures are available from Tektronix Inc. Order by part number through your local Tektronix Field Office or representative.

Test Equipment Alternatives

When equipment other than that recommended is used, control settings or test setup might need to be altered. If the exact item of equipment given as an example in the Test Equipment list is not available, first check the specifications column carefully to see if any other equipment might suffice. Then check the Usage column to see what this item is used for. If used for a check that is of little or no importance to your measurement requirements, the item and corresponding steps can be deleted.

Preparation

Connect test equipment and instrument to be calibrated to an appropriate power input source; turn on and allow a 20 minute warmup period before commencing Performance Check or Calibration.

INDEX TO PERFORMANCE CHECK

Vertical

- | | |
|------------------------------------------------------|-----|
| 1. Check Trace Rotation | 5-3 |
| 2. Check Alternate Mode | 5-3 |
| 3. Check Chop Mode | 5-3 |
| 4. Check CH 1 Balances | 5-4 |
| 5. Check CH 2 Balances | 5-4 |
| 6. Check Position Range and Centering | 5-4 |
| 7. Check Beam Finder Operation | 5-4 |
| 8. Check Ch 1 and Ch 2 Deflection Factor | 5-5 |
| 9. Check Ch 1 and Ch 2 Variable Volts/Division Range | 5-5 |

Performance Check—465 Service (SN B250000 & up)

- 10. Check Output Amplifier Low Frequency Compensation 5-5
- 11. Check Ch 1 and Ch 2 Volts/Division Compensation 5-5
- 12. Check Ch 1 and Ch 2 Transient Response 5-6
- 13. Check Ch 1 and Ch 2 Bandwidth 5-6
- 14. Check Cascade Gain and Bandwidth 5-6

Triggers

- 1. Check A and B Internal Triggering 5-7
- 2. Check A and B External Triggering 5-8
- 3. Check A Normal Mode 5-8
- 4. Check Single Sweep 5-8

- 5. Check Trigger View 5-9

Horizontal

- 1. Check A and B Time/Division Accuracy 5-10
- 2. Check A Variable Time/Division Range 5-11
- 3. Check Delay or Differential Time Linearity 5-11
- 4. Check Delay or Differential Time Accuracy 5-11
- 5. Check Delay or Differential Jitter 5-12
- 6. Check Mixed Sweep Accuracy 5-12
- 7. Check A Intensified and B ENDS A Operation 5-12
- 8. Check X Gain 5-12
- 9. Check X Bandwidth 5-13

VERTICAL

Equipment Required

- | | |
|-------------------------------------------|----------------------------------------|
| 1. Calibration Generator | 5. 50 ohm BNC Termination (2 required) |
| 2. Square-wave Generator | 6. 20 picofarad RC Input Normalizer |
| 3. Leveled Sine-Wave Generator | 7. 10X BNC Attenuator |
| 4. 42 Inch, 50 ohm BNC Cable (2 required) | |

465 CONTROL SETTINGS

POWER ON

CRT

INTENSITY As desired
 FOCUS Best focused display
 SCALE ILLUM As desired

Vertical (CH 1 and CH 2)

VERT MODE CH 1
 POSITION Midrange
 VOLTS/DIV 5 mV
 VAR VOLTS/DIV Calibrated detent
 AC-GND-DC GND
 INVERT Normal (button out)
 20 MHz BW (Pull) Full bandwidth (no yellow showing)

Trigger (A and B)

COUPLING AC
 LEVEL Midrange
 SLOPE +
 SOURCE NORM
 TRIG MODE AUTO
 A TRIG HOLDOFF NORM

Sweep (A and B)

HORIZ DISPLAY A
 TIME/DIV 1 ms
 VAR TIME/DIV Calibrated detent
 DELAY TIME POSITION Fully counterclockwise
 X10 MAG Off (button out)
 POSITION (Horizontal) Midrange
 FINE Midrange

1. Check Trace Rotation

a. Position the trace to the center horizontal graticule line.

b. Check that the trace is parallel with the center horizontal graticule line. Readjust TRACE ROTATION if necessary (Front panel screwdriver adjustment).

2. Check Alternate Mode

a. Set:

VERT MODE	ALT
A TRIGGER LEVEL	Fully clockwise
AC-GND-DC (both)	GND

b. Position the traces 2 divisions apart.

c. CHECK—The sweeps alternate in all settings of the TIME/DIV switch except X-Y.

3. Check Chop Mode

a. Set:

TIME/DIV	1 μ s
A SOURCE	NORM
VERT MODE	CHOP

b. Position the two traces about 4 divisions apart.

c. Adjust A LEVEL control for a stable display.

d. CHECK—Duration of one cycle is about 4 μ s.

CHECK—Display for blanking of switching transients.

Performance Check—465 Service (SN B250000 & up)

4. Check Ch 1 Balances

a. Set:

VERT MODE	CH 1
CH 1 VOLTS/DIV	20 mV

b. Position the trace to the center horizontal graticule line.

c. CHECK Step Attenuator Balance—Trace shift is 0.2 division or less as the CH 1 VOLTS/DIV switch is rotated from 20 mV to 5 mV.

d. Position the trace to the center horizontal graticule line.

e. CHECK Variable Balance—Trace shift is 1.0 division or less as the CH 1 VAR VOLTS/DIV control is rotated from extreme to extreme.

CHECK—CH 1 UNCAL light comes on when the VAR control is out of the detent position. Return VAR to the detent position.

5. Check Ch 2 Balances

a. Set:

VERT MODE	CH 2
CH 2 VOLTS/DIV	20 mV

b. Position the trace to the center horizontal graticule line.

c. CHECK Step Attenuator Balance—Trace shift is 0.2 division or less as the CH 2 VOLTS/DIV switch is rotated from 20 mV to 5 mV.

d. Position the trace to the center horizontal graticule line.

e. CHECK Variable Balance—Trace shift is 1.0 division or less as the CH 2 VAR VOLTS/DIV control is rotated from extreme to extreme.

CHECK—CH 2 UNCAL light comes on when the VAR control is out of the detent position. Return VAR to the detent position.

f. Position the trace to the center horizontal graticule line.

g. CHECK Invert Balance—Trace shift is 2 divisions or less when switching from normal to INVERT.

6. Check Position Range and Centering

a. Set:

CH 1 VOLTS/DIV	20 mV
CH 2 VOLTS/DIV	0.1 V
AC-GND-DC (both)	DC
A TRIGGER LEVEL	Fully Clockwise
INVERT	Normal (button out)

b. Connect the leveled sine-wave generator to the CH2 input via a 50 ohm BNC cable and a 50 ohm BNC termination. Set the generator for a 4.8 division 50 kilohertz display.

c. Set CH 2 VOLTS/DIV to 20 mV.

d. CHECK—Top of the display can be positioned down to the center horizontal graticule line, and bottom of the display can be positioned up to the center horizontal graticule line.

e. Move the signal from the CH 2 input to the CH 1 input and set the VERT MODE switch to CH 1.

f. Repeat the CHECK in Step 6, part d for CH 1.

7. Check Beam Finder Operation

a. Push in and hold the BEAM FINDER button.

b. CHECK—A compressed trace is visible regardless of the settings of the:

CH 1 POSITION control

INTENSITY control

horizontal POSITION control

c. Return the horizontal POSITION control and the INTENSITY control to midrange.

d. While still holding in the BEAM FINDER button, vertically position the trace to the center horizontal graticule line.

e. Release the BEAM FINDER button.

f. CHECK—Trace remains within the graticule area.

g. Disconnect the test equipment.

8. Check Ch 1 and Ch 2 Deflection Factor

- a. Connect a 20 millivolt standard amplitude signal from the calibration generator to the CH 1 input and set both AC-GND-DC switches to DC.
- b. CHECK—CH 1 deflection factor is within the limits given in Table 5-1.
- c. Set the VERT MODE switch to CH 2, and move the signal from the CH 1 input to the CH 2 input.
- d. CHECK—CH 2 deflection factor is within the limits given in Table 5-1.

TABLE 5-1

VOLTS /DIV Switch Setting	Standard Amplitude Signal	Vertical Deflection in Divisions	3% Tolerance in Divisions
5 mV	20 mV	4	3.88 to 4.12
10 mV	50 mV	5	4.85 to 5.15
20 mV	0.1 V	5	4.85 to 5.15
50 mV	0.2 V	4	3.88 to 4.12
0.1 V	0.5 V	5	4.85 to 5.15
0.2 V	1.0 V	5	4.85 to 5.15
0.5 V	2.0 V	4	3.88 to 4.12
1.0 V	5.0 V	5	4.85 to 5.15
2.0 V	10.0 V	5	4.85 to 5.15
5.0 V	20.0 V	4	3.88 to 4.12

9. Check Ch 1 and Ch 2 Variable Volts/Division Range

- a. Set the CH 1 and CH 2 VOLTS/DIV switches to 20 mV.
- b. Adjust the calibration generator for a 0.1 volt standard amplitude signal.
- c. CHECK—Display reduces to less than 2 divisions when the CH 2 VAR VOLTS/DIV control is turned to its extreme counterclockwise position.
- d. Move the signal to the CH 1 input and set the VERT MODE switch to CH 1.
- e. CHECK—Repeat step c using the CH 1 VAR VOLTS/DIV control.
- f. Return the VAR controls to the detent position and remove the signal from the CH 1 input.

10. Check Output Amplifier Low Frequency Compensation

- a. Set:

TIME/DIV (both)	0.2 ms
VOLTS/DIV (both)	5 mV
- b. Connect the fast-rise + output of the square-wave generator to the CH 1 input via a 50 ohm BNC cable, 10X BNC attenuator and 50 ohm BNC termination.
- c. Adjust the square-wave generator for a 5 division, 1 kilohertz display. Adjust A LEVEL control for a stable display.
- d. CHECK—Rolloff or overshoot is within 3% (0.15 division) at the frequencies listed in Table 5-2.

**TABLE 5-2
LOW FREQUENCY
COMPENSATION SETUP**

Square-Wave Generator Frequency	TIME /DIV Switch Setting
1 kHz	0.2 ms
10 kHz	20 μ s
100 kHz	2 μ s

11. Check Ch 1 and Ch 2 Volts/Division Compensation

- a. Add a 20 picofarad normalizer between the 50-ohm BNC termination and the CH 1 input.
- b. Move the test setup from the fast-rise output to the high amplitude output of the square-wave generator.
- c. Set the TIME/DIV switch to 0.2 ms and adjust the square-wave generator for a 5 division, 1 kilohertz display.
- d. CHECK—Rolloff or overshoot is within 3% (0.15 division) at all settings of the VOLTS/DIV switch between 5 mV and 0.5 V. Adjust the square-wave generator and add or remove attenuators as necessary to maintain 5 divisions of display.
- e. Move the test setup to CH 2 and set the VERT MODE switch to CH 2.
- f. CHECK—Repeat step d.

Performance Check—465 Service (SN B250000 & up)

12. Check Ch 1 and Ch 2 Transient Response

a. Set:

A TIME/DIV (both)	0.05 μ s
A TRIGGER SLOPE	+

b. Remove the 20 picofarad normalizer from the test setup. Move the test setup to the fast-rise, + output of the square-wave generator. Set the square-wave generator for a 100 kilohertz signal. Adjust the square-wave generator and add or remove attenuators as needed to maintain 5 divisions of display.

c. CHECK—Flat-top waveform within 3% or less (0.15 division) for the 5 mV, 10 mV and 20 mV positions of the VOLTS/DIV switch.

d. Move the test setup to CH 1 and set the VERT MODE switch to CH 1.

e. CHECK—Repeat step c.

f. Disconnect the test setup.

13. Check Ch 1 and Ch 2 Bandwidth

a. Set:

VOLTS/DIV (both)	5 mV
A TIME/DIV	0.2 ms
A TRIGGER LEVEL	fully clockwise

b. Connect the output of the leveled sine-wave generator to the CH 1 input via a 50 ohm BNC cable, X10 BNC attenuator and 50 ohm BNC termination.

c. Adjust the sine-wave generator for a 5 division, 50 kilohertz reference signal. Change the generator frequency to 100 megahertz.

CHECK—Display amplitude is 3.5 divisions or greater.

d. Repeat step c for all CH 1 and CH 2 VOLTS/DIV settings from 5 mV to 0.5 V. Adjust the generator and add or remove attenuators as needed to maintain a 5 division, 50 kilohertz reference signal.

e. Move the sine-wave generator output signal from the CH 1 input to the CH 2 input.

f. Repeat step c for all CH 2 VOLTS/DIV settings from 5 mV to 0.5 V.

g. Remove the test setup.

14. Check Cascade Gain and Bandwidth

a. Set:

VOLTS/DIV (both)	5 mV
TIME/DIV	1 ms
VERT MODE	CH 2

b. Connect the CH 1 OUT (on the rear panel) to the CH 2 input via a 50 ohm BNC cable and a 50 ohm BNC termination.

c. Connect a 5 mV standard amplitude signal from the calibration generator to CH 1 via a 50 ohm BNC cable.

d. CHECK—Display amplitude is 5 divisions or greater.

e. Remove the calibration generator signal from the CH 1 input.

f. Connect the output of the leveled sine-wave generator to the CH 1 input via a 50 ohm BNC cable, X10 BNC attenuator and 50 ohm BNC termination. Adjust the generator for a 5 division, 50 kilohertz display reference signal. Adjust the generator to 50 megahertz.

g. CHECK—Display amplitude is 3.5 divisions or greater.

h. Disconnect the test setup.

TRIGGERS

Equipment Required

- | | |
|-----------------------------------|-------------------------------------------|
| 1. Leveled Sine-Wave Generator | 6. 50-ohm Signal Pickoff Unit (Type CT-3) |
| 2. Calibration Generator | 7. 10X BNC Attenuator |
| 3. 42 inch BNC Cable (2 required) | 8. 2X BNC Attenuator |
| 4. GR-to-BNC-Female Adapter | 9. 50-ohm BNC Termination (2 required) |
| 5. GR-to-BNC-Male Adapter | 10. Dual Input Coupler (2 required) |

465 Control Settings

POWER ON

CRT

INTENSITY As desired
 FOCUS Best focused display
 SCALE ILLUM As desired

Vertical (CH 1 and CH 2)

VERT MODE CH 1
 POSITION Midrange
 VOLTS/DIV 5 mV
 VAR VOLTS/DIV Calibrated detent
 AC-GND-DC DC
 INVERT Normal (button out)
 20 MHz BW (Pull) Full bandwidth (No yellow showing)

Trigger (A and B)

COUPLING AC
 LEVEL Midrange
 SLOPE +
 SOURCE NORM
 TRIG MODE AUTO
 A TRIG HOLDOFF NORM

Sweep (A and B)

HORIZ DISPLAY A
 TIME/DIV 5 μ s
 VAR TIME/DIV Calibrated detent
 DELAY TIME POSITION Fully counterclockwise
 X10 MAG Off (button out)
 POSITION (horizontal) Midrange
 FINE Midrange

1. Check A and B Internal Triggering

a. Connect the output of the leveled sine-wave generator to the A and B EXT trigger inputs via a 50 ohm cable, GR-to-BNC-male adapter, 50 ohm signal pickoff unit (Type CT-3) THRU SIG OUT output, GR-to-BNC-female adapter, 50 ohm BNC cable, 2X BNC attenuator, 10X BNC attenuator, 50 ohm BNC termination and dual input coupler.

b. Connect the SIG OUT 10% on the CT-3 to the CH 1 and CH 2 inputs via a 50 ohm BNC cable, 50 ohm BNC termination and dual input coupler.

c. Adjust the leveled sine-wave generator for either a 3 division, 50 kilohertz display and set both VOLTS/DIV switches to 50 mV (0.3 division of display), or a 5 division, 50 kilohertz display and set both VOLTS/DIV switches to 50 mV (0.5 division display) as necessary for parts d and f of step 1.

d. CHECK—Stable display can be obtained by adjusting the A LEVEL control in the following A COUPLING and A SOURCE switch positions:

A COUPLING	A SOURCE	DISPLAY
AC	NORM, CH 1, CH 2	0.3 Div
DC	NORM, CH 1, CH 2	0.3 Div
LF REJ	NORM, CH 1, CH 2	0.5 Div
HF REJ	NORM, CH 1, CH 2	0.5 Div

e. Set:

HORIZ MODE B DLY'D
 A LEVEL Fully clockwise

f. CHECK—Stable display can be obtained by adjusting the B LEVEL control in the following B COUPLING and B SOURCE switch positions:

B COUPLING	B SOURCE	DISPLAY
AC	NORM, CH 1, CH 2	0.3 Div
DC	NORM, CH 1, CH 2	0.3 Div
LF REJ	NORM, CH 1, CH 2	0.5 Div
HF REJ	NORM, CH 1, CH 2	0.5 Div

Performance Check—465 Service (SN B250000 & up)

2. Check A and B External Triggering

a. Set:

CH 1 VOLTS/DIV	20 mV
A & B SOURCE	EXT
A & B COUPLING	AC

b. Adjust the leveled sine-wave generator for 5 divisions of display.

c. CHECK—Stable display can be obtained by adjusting the B LEVEL control in the following B COUPLING switch positions:

AC, DC

d. Remove the X2 BNC attenuator and set the B COUPLING switch to LF REJ then HF REJ.

e. CHECK—Stable display can be obtained by adjusting the B LEVEL control.

f. Set:

HORIZ MODE	A
A COUPLING	LF REJ and HF REJ

g. CHECK—Stable display can be obtained by adjusting the A LEVEL control.

h. Replace the X2 BNC attenuator.

i. CHECK—Stable display can be obtained by adjusting the A LEVEL control in the following A COUPLING switch positions:

AC, DC

j. Remove the X10 BNC attenuator and set the A SOURCE switch to EXT \div 10.

k. CHECK—Stable display can be obtained by adjusting the A LEVEL control in the following A COUPLING switch positions:

AC, DC

l. Remove the X2 BNC attenuator and set the A COUPLING switch to LF REJ then HF REJ.

m. CHECK—Stable display can be obtained by adjusting the A LEVEL control.

3. Check A Normal Mode

a. Set:

A COUPLING	AC
A SOURCE	NORM
TRIG MODE	AUTO

b. Adjust A LEVEL for a stable display.

c. Set the TRIG MODE switch to NORM.

d. CHECK—Stable display is visible.

e. Set the CH 1 AC-GND-DC switch to GND.

f. CHECK—No visible display in the absence of an adequate trigger signal.

4. Check Single Sweep

a. Set the CH 1 AC-GND-DC switch to DC.

b. Adjust A LEVEL until the display just triggers.

c. Set the CH 1 AC-GND-DC switch to GND.

d. Push the SINGL SWP button.

e. CHECK—READY light comes on and stays on.

f. Set the CH 1 AC-GND-DC switch to DC.

g. CHECK—READY light goes out and a single sweep occurs.

h. Push the SINGL SWP button.

i. CHECK—Single sweep occurs every time the SINGL SWP button is pushed.

j. Disconnect the test setup.

Performance Check—465 Service (SN B250000 & up)

5. Check Trigger View

a. Set:

A TIME/DIV	0.2 ms
A COUPLING	DC
A SOURCE	EXT
TRIG MODE	AUTO

b. Connect a 200 millivolt standard amplitude signal from the calibration generator to the A EXT input.

c. Push the TRIG VIEW button and hold it in. Adjust A TRIGGER LEVEL for an on-screen display.

d. CHECK—Display amplitude is 3.2 to 4.8 divisions.

e. Disconnect the test setup.

Performance Check—465 Service (SN B250000 & up)

IMPORTANT NOTE

OSCILLOSCOPES WITH DIGITAL MULTIMETERS ATTACHED, REFER TO THE DIGITAL MULTIMETER MANUAL AT THIS POINT, THEN RETURN TO STEP 8 IN THE HORIZONTAL SECTION.

OSCILLOSCOPES WITHOUT DIGITAL MULTIMETERS, CONTINUE WITH THIS PROCEDURE.

HORIZONTAL

Equipment Required	
1. Time-Mark Generator	3. Leveled Sine-Wave Generator
2. Calibration Generator	4. 42 Inch, 50 ohm BNC Cable
	5. 50 ohm BNC Termination

465 Control Settings

POWER ON

CRT

INTENSITY As desired
 FOCUS Best focused display
 SCALE ILLUM As desired

VERTICAL (CH 1 and CH 2)

VERT MODE CH 1
 POSITION Midrange
 VOLTS/DIV 0.5 V
 VAR VOLTS/DIV Calibrated detent
 AC-GND-DC DC
 INVERT Normal (button out)
 20 MHz BW (PULL) Full bandwidth (No yellow showing)

TRIGGER (A and B)

COUPLING AC
 LEVEL Midrange
 SLOPE +
 A SOURCE NORM
 B SOURCE NORM
 TRIG MODE AUTO
 A TRIG HOLDOFF NORM

SWEEP (A and B)

HORIZ DISPLAY A
 TIME/DIV 1 ms
 VAR TIME/DIV Calibrated detent
 DELAY TIME POSITION Fully counterclockwise
 X10 MAG Off (button out)
 POSITION (horizontal) Midrange
 FINE Midrange

1. Check A and B Timing Accuracy

a. Connect the time-mark generator to CH 1 via a 50 ohm BNC cable and a 50 ohm BNC termination.

b. CHECK—A and B timing accuracy according to Table 5-3. Timing to be accurate within 3% (0.3 division at the 11th time marker). If 11 time markers are not visible when checking B sweep, set the A TIME/DIV switch one step slower than the B TIME/DIV switch.

i.e.

A TIME/DIV 1 ms
 B TIME/DIV 0.5 ms

When checking B timing, set HORIZ DISPLAY to B DLY'D and use B LEVEL to stabilize the display.

A AND B TIMING ACCURACY

A and B TIME/DIV Switch Setting	Time-Mark Generator Output	CRT Display (Markers/Division)
0.05 μ s	50 ns	1
.1 μ s	0.1 μ s	1
.2 μ s	0.1 μ s	2
.5 μ s	0.5 μ s	1
1 μ s	1 μ s	1
2 μ s	1 μ s	2
5 μ s	5 μ s	1
10 μ s	10 μ s	1
20 μ s	10 μ s	2
50 μ s	50 μ s	1
.1 ms	0.1 ms	1
.2 ms	0.1 ms	2
.5 ms	0.5 ms	1
1 ms	1 ms	1
2 ms	1 ms	2
5 ms	5 ms	1
*10 ms	10 ms	1
*20 ms	10 ms	2
*50 ms	50 ms	1

Performance Check—465 Service (SN B250000 & up)

TABLE 5-3 (cont)

A and B TIME/DIV Switch Setting	Time-Mark Generator Output	CRT Display (Markers/Division)
A SWEEP ONLY		
*.1 s	0.1 s	1
*.2 s	0.1 s	2
*.5 s	0.5 s	1

*Set the TRIG MODE switch to NORM

2. Check A Variable Time/Division Range

a. Set:

HORIZ MODE	A
TRIG MODE	AUTO
TIME/DIV	2 ms

b. Select 5 millisecond time marks from the time mark generator.

c. CHECK—At least 1 marker per division can be obtained by adjusting the VAR TIME/DIV control.

d. Return the VAR TIME/DIV control to the detent position.

3. Check Delay or Differential Time Linearity

a. Set:

A TIME/DIV	1 ms
B TIME/DIV	5 μ s
HORIZ DISPLAY	B DLY'D

b. Set the time mark generator for 1 millisecond time marks and set B SOURCE to STARTS AFTER DELAY.

c. Set the DELAY TIME POSITION dial to position the tenth time marker to the beginning of the trace (about 10.00).

d. Note the reading on the DELAY TIME POSITION dial.

e. Adjust the DELAY TIME POSITION dial so that the ninth time marker is at the beginning of the trace.

f. CHECK—DELAY TIME POSITION dial for a reading one division less, within 0.01 division from +15°C to +35°C; (one division less, within 0.03 division from -15°C to +55°C) than the reading noted in step d.

g. Rotate the DELAY TIME POSITION dial to position each successive time marker to the beginning of the sweep.

h. CHECK—DELAY TIME POSITION dial for a reading of one division less, within 0.01 division from +15°C to +35°C (one division less, within 0.03 division from -15°C to +55°C) than the adjacent time marker.

4. Check Delay or Differential Time Accuracy

a. Set:

B SOURCE	STARTS AFTER DELAY
A TIME/DIV	0.2 μ s
B TIME/DIV	0.05 μ s

b. Set the A TIME/DIV, B TIME/DIV and the time mark generator to the settings given in Table 5-4. First set the DELAY TIME POSITION dial to 1.00. Adjust the horizontal

**TABLE 5-4
DELAY OR DIFFERENTIAL TIME ACCURACY**

A TIME/DIV Switch Setting	B TIME/DIV Switch Setting	Time-Mark Generator Output
.2 μ s	0.05 μ s	.1 μ s
.5 μ s	0.05 μ s	.5 μ s
1 μ s	.1 μ s	1 μ s
2 μ s	.1 μ s	1 μ s
5 μ s	.5 μ s	5 μ s
10 μ s	1 μ s	10 μ s
20 μ s	1 μ s	10 μ s
50 μ s	5 μ s	50 μ s
.1 ms	10 μ s	.1 ms
.2 ms	10 μ s	.1 ms
.5 ms	50 μ s	.5 ms
1 ms	.1 ms	1 ms
2 ms	.1 ms	1 ms
5 ms	.5 ms	5 ms
*10 ms	1 ms	10 ms
*20 ms	1 ms	10 ms
*50 ms	5 ms	50 ms
*.1 s	10 ms	.1 s
*.2 s	10 ms	.1 s
*.5 s	50 ms	.5 s

*Set the TRIG MODE switch to NORM.

Performance Check—465 Service (SN B250000 & up)

POSITION control so the top of the displayed time mark crosses the center vertical graticule line. (If the top of the time marker at the beginning of the sweep isn't visible, then use the time mark near the end of the sweep). Without touching the horizontal POSITION control, set the DELAY TIME POSITION dial to 9.00. Slightly readjust the DELAY TIME POSITION dial to position the top of the displayed time mark to the center vertical graticule line.

CHECK—DELAY TIME POSITION dial setting to be 8.92 to 9.08.

Repeat the above for each of the settings listed in Table 5-4.

5. Check Delay or Differential Jitter

a. Set:

DELAY TIME POSITION	9.00
HORIZ DISPLAY	B DLY'D
A TIME/DIV	1 ms
B TIME/DIV	0.2 μ s
B SOURCE	STARTS AFTER DELAY

b. Select 1 ms time marks.

c. Slightly readjust the DELAY TIME POSITION dial to position the time mark on screen.

d. CHECK—Jitter on the leading edge of the time marker does not exceed 1 division (2.5 divisions if operating from a 50 hertz line voltage). Disregard the slow drift.

e. Set the DELAY TIME POSITION dial to 1.00 and repeat parts c and d.

6. Check Mixed Sweep Accuracy

a. Set:

A TIME/DIV	1 ms
B TIME/DIV	.5 ms
DELAY TIME POSITION	Fully clockwise
HORIZ DISPLAY	A

b. Select 1 ms time marks.

c. CHECK—Timing error between the second and the tenth time marks.

Note the amount of error for step e.

d. Set the HORIZ DISPLAY switch to MIX.

e. CHECK—Timing between the second and tenth time marks is within 0.18 division \pm the error noted in step c.

f. Disconnect the time mark generator.

7. Check A Intensified and B Ends A

a. Set:

A TIME/DIV	1 ms
B TIME/DIV	.1 ms
DELAY TIME POSITION	About 5.00
HORIZ DISPLAY	A INTEN

b. CHECK—B portion of the trace is intensified (about 1 division).

c. Rotate A TRIG HOLDOFF control clockwise to the B ENDS A position (in the detent).

d. CHECK—Trace ends at the end of the intensified portion.

8. Check X Gain

a. Set:

TIME/DIV (both)	X-Y
VERT MODE	CH 2
VOLTS/DIV (both)	5 mV
CH 1 AC-GND-DC	AC
CH 2 AC-GND-DC	GND
HORIZ DISPLAY	A
A TRIG HOLDOFF	Fully counterclockwise

b. Connect a 20 millivolt standard amplitude signal from the calibration generator to the CH 1 input via a 50 ohm BNC cable.

c. CHECK—Display is 4 divisions (\pm 0.16 division) between the dots.

d. Set CH 1 AC-GND-DC switch to DC.

e. CHECK—Display is 4 divisions (\pm 0.16 division) between the dots. It is normal for this CHECK to be slightly shorter than that in step c.

Performance Check—465 Service (SN B250000 & up)

f. Set the calibration generator for a 50 millivolt standard amplitude signal.

g. CHECK—Display is 10 divisions (± 0.4 division) between the dots.

h. Set the CH 1 AC-GND-DC switch to AC.

i. CHECK—Display is 10 divisions (± 0.4 division) between the dots. It is normal for this CHECK to be slightly longer than step g.

j. Disconnect the test setup.

9. Check X Bandwidth

a. Connect the leveled sine-wave generator to the CH 1 input via a 50 ohm BNC cable and 50 ohm BNC termination.

b. Adjust the generator for a 10 division display of a 50 kilohertz reference signal.

c. Without touching the generator amplitude, adjust the generator frequency to 4 megahertz.

d. CHECK—Display is at least 7 divisions in length.

e. Disconnect the test setup.

CALIBRATION

IMPORTANT—PLEASE READ BEFORE USING THIS PROCEDURE

Purpose

The purpose of the calibration procedure is to provide a calibration sequence for adjustments—not to provide a troubleshooting guide. See the Troubleshooting Aids portion of the Maintenance section for troubleshooting information.

Limits and Tolerances

All limits and tolerances given in this procedure are calibration guides and should not be interpreted as instrument specifications unless they are also found in the Specifications section of this manual.

Tolerances given are for the instrument under test and do not include test equipment error.

Step Titles

Where possible, instrument performance is checked before an adjustment is made. Steps containing checks and adjustments are titled Check/Adjust. Those with checks only are titled Check.

Line Voltage Selection

This procedure is for 115 volt ac line, medium range. If a different range is to be used, set the Regulating Range Selector and Line Voltage Selector for the available line voltage (see item 42 under Controls and Connectors in Section 2).

Internal Adjustments

Do not preset the internal controls or move the +55 volt supply adjustment as this will typically require complete recalibration of the oscilloscope.

Display

The most accurate display adjustments are made with a stable, well-focused, low-intensity display. Unless otherwise noted, adjust the Intensity, Astigmatism, Focus, and Trigger Level controls as needed.

Test Equipment Required

The test equipment listed in Table 6-2, or equivalent, is required for complete calibration of the oscilloscope. Specifications given for the equipment are the minimum necessary for accurate calibration. Therefore, the equipment used must meet or exceed the listed specifications.

Detailed operating instructions for the test equipment are not given in this procedure. Refer to the appropriate instruction manual if more information is needed.

Special Calibration Fixtures. Special calibration fixtures are used only where they facilitate instrument calibration. These fixtures are available from Tektronix Inc. Order by part number through your local Tektronix Field Office or Representative.

Calibration Equipment Alternatives and Partial Procedures. The Calibration procedure is based on the first item of equipment given as an example. When other equipment is substituted, control settings or calibration setups might need to be altered. If the exact equipment listed is not available, check the specifications column carefully to see if any other equipment might suffice. Then check the usage column to see what this item is used for. If used for a check that is of little or no importance to your measurement requirements, the item and corresponding step(s) can be deleted.

If the applications for which you will use the 465 do not require the full performance available, the procedure and the equipment list can be shortened accordingly. For example, the basic measurement capabilities of this instrument can be verified by checking and adjusting as needed: vertical deflection factor, horizontal timing accuracy, and the calibrator signal. If any step requires more than a minor readjustment, check Table 6-1 for any possible interactions.

Interactions

Table 6-1 shows calibration adjustments and the possible interaction each adjustment might have on other adjustments. The use of Table 6-1 is particularly important if only a partial procedure is performed or if a circuit requires recalibration due to component replacement.

To use this table, find the adjustment made in the column at the left of the table. Then move to the right across that row until you come to a darkened square. From the darkened square move up the column and check the accuracy of the adjustment titling that column. Readjust if necessary.

Preparation

Connect test equipment and instrument to be calibrated to an appropriate power input source; turn on and allow a 20 minute warmup period before commencing Performance Check or Calibration.

**TABLE 6-1
ADJUSTMENT INTERACTIONS**

Adjustment made	H. V. SUPPLY	TRACE ROTATION	Y-AXIS ALIGNMENT	GEOMETRY	STEP ATTENUATOR BALANCE	CH 1 VARIABLE BALANCE	CH 2 VARIABLE BALANCE	INVERT BALANCE	VERT OUT POSITION CENTERING	CH 1 POSITION CENTERING	CH 1 GAIN	CH 2 GAIN	VERT OUT GAIN	SWP START AND A SWP CAL	X1 HORIZONTAL GAIN	X10 HORIZONTAL GAIN	B SWP CAL	0.5 μ TIMING (A AND B)	HIGH SPEED MAG TIMING	TRIGGER SENSITIVITY (A AND B)	SLOPE CENTERING (A AND B)	TRIGGER LEVEL CENTERING (A AND B)	NORMAL DC BALANCE	CH 1 DC BALANCE	CH 2 DC BALANCE	TRIGGER VIEW CENTERING	X GAIN	CRT GRID BIAS	CRT	
H. V. SUPPLY																														
TRACE ROTATION																														
Y-AXIS ALIGNMENT																														
GEOMETRY																														
STEP ATTENUATOR BALANCE																														
CH 1 VARIABLE BALANCE																														
CH 2 VARIABLE BALANCE																														
INVERT BALANCE																														
VERT OUT POSITION CENTERING																														
CH 1 POSITION CENTERING																														
CH 1 GAIN																														
CH 2 GAIN																														
VERT OUT GAIN																														
SWP START AND A SWP CAL																														
X1 HORIZONTAL GAIN																														
X10 HORIZONTAL GAIN																														
B SWP CAL																														
0.5 μ TIMING (A AND B)																														
HIGH SPEED MAG TIMING																														
TRIGGER SENSITIVITY (A AND B)																														
SLOPE CENTERING (A AND B)																														
TRIGGER LEVEL CENTERING (A AND B)																														
NORMAL DC BALANCE																														
CH 1 DC BALANCE																														
CH 2 DC BALANCE																														
TRIGGER VIEW CENTERING																														
X GAIN																														
CRT GRID BIAS																														
CRT																														

NOTE

For 465's with the IC version of the Vertical Output Amplifier, adjusting the Vertical Output bias affects Vertical Output Gain and High Frequency compensation.

TABLE 6-2
TEST EQUIPMENT REQUIRED

Description	Minimum Specifications	Usage	Examples
1. Variable Autotransformer	Capable of Supplying 1.2 amperes over a range of 103.5 to 126.5 volts.	Power supply regulation check.	General Radio W8MT3VM Variac Autotransformer.
2. Digital Voltmeter ¹	Range, 0 to 140 volts; dc voltage accuracy, within 0.15%; display, 4 1/2 digits.	Low-Voltage Power Supply checks and adjustments. CRT Grid Bias adjustment. Vertical and Horizontal Centering adjustments. Calibrator Output Voltage adjustment.	a. Tektronix DM 501 Digital Multimeter. ¹ b. Any digital voltmeter that meets minimum specifications.
3. DC Voltmeter	Range, 0 to 2500 volts; calibrated to 1% accuracy at -2450 volts.	High-Voltage Power Supply adjustment.	a. Triplet Model 630-NA. b. Simpson Model 262.
4. Test Oscilloscope with 10X probe and 1X probe. (1X probe is an optional accessory)	Bandwidth, DC to 100 megahertz; minimum deflection factor, 5 mV/division; accuracy, within 3%; dual trace.	Power Supply Ripple Check. CRT Z-Axis Compensation; Vertical gain adjustment. A Trigger Holdoff check. A and B + Gate Output Signals check.	a. Tektronix 465 Oscilloscope with 2 (included) 10X probes. b. Tektronix 475 Oscilloscope with 2 (included) 10X probes. c. Tektronix P6101 1X probe 010-6101-03.
5. Amplitude Calibrator	Amplitude accuracy, within 0.25%; signal amplitude, 2 millivolts to 50 volts; output signal, 1 kilohertz square wave.	Vertical checks and adjustments. Trigger View Gain check. X Gain adjustment. External Z-Axis check.	a. Tektronix PG 506 Calibration Generator. ¹ b. Tektronix 067-0502-01 calibration fixture.
6. Sine-wave Generator	Frequency, 350 kilohertz to above 100 megahertz; output amplitude, variable from 0.5 to 5.5 volts peak-to-peak; output impedance, 50 ohms; reference frequency, 50 to 350 kilohertz; amplitude accuracy, constant within 3% of reference frequency as output frequency changes.	Vertical Centering. Bandwidth and Isolation checks. Trigger checks and adjustments. X-Y Phase Difference. X Bandwidth check.	a. Tektronix SG 503 Leveled Sine-wave Generator. ¹ b. Tektronix Type 191 Constant-Amplitude Signal Generator.
7. Time-Mark Generator	Marker outputs, 2 nanoseconds to 0.5 second; marker accuracy, within 0.1%; trigger output, 1 millisecond to 0.1 microsecond, time coincident with markers.	CRT Y-Axis and geometry adjustments. Auto Trigger check. Horizontal timing checks and adjustments.	a. Tektronix TG 501 Time-Mark Generator. ¹ b. Tektronix 2901 Time-Mark Generator.

¹Requires a TM 500 series power module.

TABLE 6-2 (cont)

Description	Minimum Specifications	Usage	Examples
8. Low-Frequency Generator	Frequency, 60 hertz and 1 kilohertz; output amplitude, variable from 30 millivolts to 4 volts peak-to-peak.	Low-Frequency Trigger check:	a. Tektronix SG 502 Oscillator. ¹ b. General Radio 1310A Oscillator.
9. Square-Wave Generator	Repetition rate, 1 to 100 kilohertz; risetime, 1 nanosecond or less from fast-rise output; output amplitude, 60 volt pulse supplying at least 10 milliamperes from high-amplitude output; aberrations, within 2% from fast-rise output.	Vertical Compensation.	a. Tektronix PG 506 Calibration Generator ¹ . b. Tektronix Type 106 Square-Wave Generator.
10. 50-Ohm Signal Pickoff	Frequency response, 50 kilohertz to 100 megahertz; impedance 50 ohms for signal input, signal output and trigger output.	Trigger checks and adjustments.	Tektronix CT-3 Signal Pick-off. Part Number 017-0061-00.
11. Cable (2 Required)	Impedance, 50 ohms; Length, 42 inches; Connectors, BNC	Signal interconnection.	Tektronix Part Number 012-0057-01.
12. Cable (2 Required)	Impedance, 50 ohms; Length, 18 inches; Connectors, BNC	Signal interconnection.	Tektronix Part Number 012-0076-00.
13. Adapter	Connectors, GR874 to BNC female	Signal interconnection.	Tektronix Part Number 017-0063-00.
14. Adapter	Connectors, GR874-to-BNC-male	Signal interconnection.	Tektronix Part Number 017-0064-00.
15. Adapter	Connectors, BNC female to BNC female.	Signal interconnection.	Tektronix Part Number 103-0028-00.
16. Dual-Input Coupler (2 required)	Connectors, BNC female to 2 BNC male.	Vertical checks. Trigger checks and adjustments. X-Y Phase check.	Tektronix Part Number 067-0525-01.
17. T Connector	Connectors, BNC	Signal interconnection.	Tektronix Part Number 103-0030-00.
18. 10X Attenuator (2 required)	Ratio, 10X; impedance, 50 ohms; connectors, BNC	Vertical Compensation. Vertical Bandwidth check. Trigger adjustments.	Tektronix Part Number 011-0059-02.
19. 5X Attenuator	Ratio, 5X; impedance, 50 ohms; connectors, BNC	Vertical System Compensation adjustments. Trigger adjustments.	Tektronix Part Number 011-0060-02.
20. 2X Attenuator	Ratio, 2X; impedance, 50 ohms; connectors, BNC.	Vertical System Compensation. Trigger adjustments.	Tektronix Part Number 011-0069-02.

¹Requires a TM 500 series power module.

TABLE 6-2 (cont)

Description	Minimum Specifications	Usage	Examples
21. Termination (2 required)	Impedance, 50 ohms; connectors, BNC	Signal termination.	Tektronix Part Number 011-0049-01.
22. Input RC Normalizer	RC time constant, 1 megohm times 20 picofarads; connectors, BNC.	Vertical Input Attenuator Compensation.	Tektronix input RC Normalizer calibration fixture. Part Number 067-0538-00.
23. Screw-driver	Length, three-inch shaft, bit size, 3/32 inch.	Adjust variable resistors.	Xcelite R-3323.
24. Low-Capacitance Screw-driver	Length, 1-inch shaft; bit size, 3/32 inch.	Adjust all variable capacitors.	J.F.D. Electronics Corp. Adjustment Tool Number 5284.
25. Shorting Strap		Calibrator adjustment.	

INDEX TO CALIBRATION PROCEDURE

		7. Check/Adjust Vertical Output Centering	6-14
		8. Check/Adjust Ch 1 Step Attenuator Balance	6-14
Power Supply	Page	9. Check/Adjust Ch 1 Variable Volts/Div Balance	6-14
1. Check/Adjust Power Supply DC Levels, Regulation and Ripple	6-8	10. Check/Adjust Ch 2 Step Attenuator Balance	6-15
2. Check/Adjust High Voltage Supply	6-9	11. Check/Adjust Ch 2 Variable Volts/Div Balance	6-15
Display and Z Axis		12. Check/Adjust Ch 2 Invert Balance	6-15
1. Check/Adjust CRT Grid Bias	6-10	13. Check/Adjust Ch 2 Position Centering	6-15
2. Check/Adjust Trace Alignment	6-10	14. Check/Adjust Ch 1 Position Centering	6-15
3. Check/Adjust Y-Axis Alignment	6-11	15. Check Beam Finder Operation	6-16
4. Check/Adjust Geometry	6-11	16. Check/Adjust Ch 1 and Vertical Output Gain	6-16
5. Check/Adjust Z-Axis Compensation	6-11	17. Check/Adjust Ch 2 Gain	6-16
Vertical		18. Check Ch 1 and Ch 2 Variable Volts/Division Range	6-16
1. Check Probe Coding Indicator Lights	6-13	19. Check Add Mode	6-17
2. Check CH 1 and CH 2 Gate Current	6-13	20. Check Compression and Expansion	6-17
3. Check AC-GND-DC Switches	6-13	21. Check/Adjust Vertical Output Low Frequency Compensation	6-17
4. Check Alternate Mode	6-13		
5. Check Chop Mode	6-13		
6. Adjust Vertical Output Bias	6-14		

Calibration—465 Service (SN B250000 & up)

22. Check/Adjust Ch 1 Volts/Division Compensation	6-18	12. Check A Internal 100 megahertz Triggering	6-30
23. Check/Adjust Ch 2 Volts/Division Compensation	6-18	13. Check B Internal 100 megahertz Triggering	6-30
24. Check/Adjust Ch 2 and Vertical Output High Frequency Compensation	6-19	14. Check A & B High Frequency Reject Triggering	6-31
25. Check Ch 2 Position Effect	6-19	15. Check Single Sweep	6-31
26. Check/Adjust Ch 2 10 millivolt and 20 millivolt High Frequency Compensation	6-20	16. Check 60 Hertz Internal Triggering	6-31
27. Check/Adjust Ch 1 High Frequency Compensation	6-20	17. Check 60 Hertz External Triggering	6-32
28. Check Ch 1 Position Effect	6-21	18. Check A & B External Trigger Level Ranges	6-33
29. Check/Adjust Ch 1 10 millivolt and 20 millivolt High Frequency Compensation	6-21	19. Check Line Triggers	6-33
30. Check Bandwidth	6-21	20. Check A Normal Mode	6-34
31. Check Cascade Gain and Bandwidth	6-22	21. Check Auto Recovery Time	6-34
32. Check Channel Isolation	6-22	22. Check/Adjust Trigger View Centering	6-34
33. Check Common Mode Rejection Ratio	6-22	23. Check Trigger View Gain	6-34
34. Check Bandwidth Limit Operation	6-23	Horizontal	
Triggers		1. Check/Adjust Sweep Start and A Sweep Calibration	6-35
1. Check/Adjust A Trigger Sensitivity and TRIG Lamp	6-24	2. Check Delay or Differential Time Linearity	6-36
2. Check/Adjust B Trigger Sensitivity	6-25	3. Check/Adjust Horizontal Amplifier Gain	6-36
3. Check/Adjust B Trigger Slope and Level Centering	6-26	4. Check Sweep Linearity	6-37
4. Check/Adjust A Trigger Slope and Level Centering	6-26	5. Check/Adjust Magnifier Registration	6-37
5. Check/Adjust A Trigger DC Levels	6-26	6. Check/Adjust B Sweep Calibration	6-37
6. Check B Trigger DC Levels	6-27	7. Check A Sweep Length	6-37
7. Check B Internal 25 megahertz Triggering	6-27	8. Check Variable Time/Division	6-37
8. Check A Internal 25 megahertz Triggering	6-28	9. Check Horizontal Position Range	6-37
9. Check A External 25 megahertz Triggering	6-28	10. Check/Adjust A 10 μ s Timing	6-38
10. Check B External 25 megahertz Triggering	6-29	11. Check/Adjust A Sweep High Speed Timing	6-38
11. Check B and A External 100 megahertz Triggering	6-29	12. Check/Adjust B Sweep High Speed Timing	6-38
		13. Check A and B Time/Division Accuracy	6-39

Calibration—465 Service (SN B250000 & up)

14. Check/Adjust High Speed Magnified Timing	6-39
15. Check A and B Magnified Timing Accuracy	6-39
16. Check Delay or Differential Time Accuracy	6-40
17. Check Delay or Differential Time Jitter	6-40
18. Check Mixed Sweep Accuracy	6-40
19. Check/Adjust X Gain	6-41

20. Check X-Y Phasing and Bandwidth	6-41
21. Check B Ends A	6-41
22. Check A Trigger Holdoff	6-41

Gates, Calibrator and Ext Z Axis

1. Check A and B + Gates	6-43
2. Check/Adjust Calibrator DC Level	6-44
3. Check External Z Axis	6-44

POWER SUPPLY

Equipment Required	
1. Digital Voltmeter	3. Test Oscilloscope
2. DC Voltmeter	4. Autotransformer
	5. 3 Inch slotted Screwdriver

See **ADJUSTMENT LOCATIONS 1** in the Diagrams section for adjustments and test points (TP).

NOTE

After performing the following control settings, connect the instrument to a power source through a Variable Autotransformer. Set the Autotransformer to 115 V before turning the instrument on.

465 Control Settings

Power Controls

Regulating Range Selector	Medium
Line Voltage Selector	115 V
POWER	ON

CRT Controls

INTENSITY	As desired
FOCUS	Best focused display
SCALE ILLUM	As desired

**Vertical Controls
(both Channels if applicable)**

VOLTS/DIV	5 mV
VAR	Calibrated detent
POSITION	Midrange
AC-GND-DC	GND
VERT MODE	CH 1
INVERT	Normal (button out)
20 MHz BW (Pull)	Off (No yellow showing)

**Triggering Controls
(both A and B if applicable)**

LEVEL	As needed for a stable display
SLOPE	+
COUPLING	AC
SOURCE	NORM
TRIG MODE	AUTO

Sweep Controls

HORIZ DISPLAY	A
DELAY TIME POSITION	Fully counterclockwise
A TIME/DIV	1 ms
B TIME/DIV	1 ms
VAR TIME/DIV	Calibrated detent
X10 MAG	Off (button out)
POSITION	Midrange
FINE	Midrange
A TRIG HOLDOFF	NORM

1. Check/Adjust Power Supply DC Levels, Regulation and Ripple

NOTE

Review the information at the beginning of the Calibration Section before starting Calibration.

a. Connect the digital voltmeter between the test point given in Table 6-3 and ground. Voltage to be within the given limits.

TABLE 6-3

LOW VOLTAGE POWER SUPPLY LIMITS

Power Supply	Test Point	Reading	Tolerance
+55 V	TP1536	+54.72 to +55.27	±0.5%
+15 V	TP1548	+14.77 to +15.22	±1.5%
+5 V	TP1558	+4.92 to +5.07	±1.5%
-8 V	TP1568	-8.12 to -7.880	±1.5%
+110 V	TP1518	+107.8 to +113.4	+3%; -2%

NOTE

If the adjustment in step 1b is made, the oscilloscope will require complete recalibration.

b. Connect the digital voltmeter to TP1536: ADJUST +55 volt supply (R1538) for +55 volts. Recheck all supplies according to Table 6-3.

c. Connect the test oscilloscope to the indicated test point and check the ripple amplitude according to Table 6-4 while varying the line voltage between 103.5 volts and 126.5 volts. For improved resolution when measuring ripple amplitude, use a 1X probe and cascaded gain on the test oscilloscope.

**TABLE 6-4
TYPICAL LOW VOLTAGE
POWER SUPPLY RIPPLE**

Power Supply	Test Point	Typical Ripple (Peak-to-Peak)
+55 V	TP1536	4 mV
+15 V	TP1548	2 mV
+5 V	TP1558	2 mV
-8 V	TP1568	2 mV
+110 V	TP1518	20 mV

d. Return line voltage to 115 volts.

2. Check/Adjust High Voltage Supply

a. Connect the dc voltmeter between TP1423 and ground on the interface board (TP1423 is accessible through a hole in the high voltage cover).

b. CHECK—High Voltage supply for -2450 volts $\pm 2\%$ (-2401 volts to -2499 volts).

c. ADJUST—High Voltage (R1400) for -2450 volts.

d. Disconnect the dc voltmeter from the 465.

DISPLAY AND Z AXIS

Equipment Required

- | | |
|------------------------|----------------------------------------|
| 1. DC Voltmeter | 5. 50-ohm BNC Termination |
| 2. Test Oscilloscope | 6. X10 Probe |
| 3. Time Mark Generator | 7. 3 Inch slotted Screwdriver |
| 4. 50-ohm BNC Cable | 8. Low Capacitance slotted Screwdriver |

See **ADJUSTMENT LOCATIONS 1** in the Diagrams section for adjustments and test points (TP).

465 Control Settings (*Indicates Changes From the Previous Step)

Power Controls

Regulating Range Selector Medium
 Line Voltage Selector 115 V
 POWER ON

CRT Controls

INTENSITY As desired
 FOCUS Best focused display
 *SCALE ILLUM *Fully counterclockwise

Vertical Controls (both Channels if applicable)

VOLTS/DIV 5 mV
 VAR Calibrated detent
 POSITION Midrange
 AC-GND-DC GND
 VERT MODE CH 1
 INVERT Normal (button out)
 20 MHz BW (Pull) Off (No yellow showing)

Triggering Controls (both A and B if applicable)

LEVEL As needed for a stable display
 SLOPE +
 COUPLING AC
 SOURCE NORM
 TRIG MODE AUTO

Sweep Controls

HORIZ DISPLAY A
 DELAY TIME POSITION Fully counterclockwise
 *A TIME/DIV *X-Y
 *B TIME/DIV *X-Y
 VAR TIME/DIV Calibrated detent
 X10 MAG Off (button out)
 POSITION Midrange
 FINE Midrange
 A TRIG HOLDOFF NORM

1. Check/Adjust CRT Grid Bias

- Connect the digital voltmeter between TP1486 and ground. (TP1486 is accessible through a hole in the high voltage cover.)
- Set the INTENSITY control for +20 volts on the digital voltmeter.
- CHECK—Display for a well defined, low intensity dot. Use FOCUS and ASTIG controls as needed.
- ADJUST—Grid Bias (R1480) for a visible dot, then back until the dot just disappears.

2. Check/Adjust Trace Alignment

- Set:

A TIME/DIV	0.5 ms
INTENSITY	as desired
SCALE ILLUM	as desired

Calibration—465 Service (SN B250000 & up)

b. Position the trace to the center horizontal graticule line.

c. CHECK—Trace is parallel with the center horizontal graticule line.

d. ADJUST—TRACE ROTATION (front panel adjustment) to make the trace parallel with the center horizontal graticule line.

3. Check/Adjust Y-Axis Alignment

a. Connect 1 ms time marks from the time-mark generator to the CH 1 input via a 50 ohm BNC cable and a 50 ohm BNC termination.

b. Set:

CH 1 AC-GND-DC	DC
CH 1 VOLTS/DIV	0.1 V

c. Adjust VAR TIME/DIV control for exactly 1 time mark/major division. (Time marks should fill the screen vertically. If not, reduce the VOLTS/DIV switch setting.)

d. CHECK—Display for 0.1 division tilt or less, when compared to the center vertical graticule line.

e. ADJUST—Y-Axis Alignment (R1446) to align the center time mark with the center vertical graticule line.

f. INTERACTION—TRACE ROTATION.

4. Check/Adjust Geometry

a. CHECK—Display for 0.1 division or less, vertical curvature of the markers across the graticule area. (Readjust A VAR TIME/DIV as needed to maintain exactly 1 mark per division.)

b. ADJUST—Geometry (R1442) for minimum curvature of the markers across the graticule area.

c. INTERACTION—Y-Axis Alignment.

d. Disconnect the test setup.

e. Return A VAR TIME/DIV to detent.

5. Check/Adjust Z-Axis Compensation

a. Set the A TIME/DIV switch to 0.05 μ s.

b. Connect the X10 probe from the test oscilloscope to TP1486.

c. Adjust the 465 INTENSITY control for a 15 volt display on the test oscilloscope.

d. CHECK—Test oscilloscope display for optimum square corner on the unblanking gate (with minimum ringing).

e. ADJUST—Z-Axis Compensation (C1471) with a low capacitance screwdriver for the best square corner on the unblanking pulse viewed on the test oscilloscope.

f. Disconnect the test setup.

g. CHECK—Display for uniform intensity across the graticule area (especially the first 2 divisions of the trace).

h. READJUST—C1471, if necessary.

VERTICAL

Equipment Required

- | | |
|--------------------------------------------------------------------------------------------------------------------------------------------------|----------------------------------------|
| 1. Calibration Generator | 7. Dual-Input Coupler |
| 2. Test Oscilloscope with two 10X probes | 8. X10 BNC Attenuator (2 required) |
| 3. Square-wave Generator | 9. 50 ohm BNC Termination (2 required) |
| 4. Leveled Sine-Wave Generator | 10. 20 picofarad BNC Normalizer |
| 5. 11 kilohm resistor (see Step 1, part a)
used if either of the 10X probes in item 2 above
do not have scale factor switching connectors. | 11. Low-Capacitance Screwdriver |
| 6. 50 ohm BNC Cable (2 required) | 12. 3 Inch slotted Screwdriver |

See **ADJUSTMENT LOCATIONS 2** and **ADJUSTMENT LOCATIONS 3a** or **ADJUSTMENT LOCATIONS 3b** in the Diagrams section for adjustments and test points (TP).

Some instruments have an output stage (and output circuit board) using an integrated circuit (IC). Other instruments contain individual transistors in the output stage (discrete). The pull-out pages ADJUSTMENT LOCATIONS 3a & 3b permit easy identification of the board in your instrument. The calibration procedure indicates the IC output stage adjustments by double boxes.

*POSITION	*Midrange
AC-GND-DC	DC
VERT MODE	CH 1
INVERT	Off (button out)
20 MHz BW (Pull)	Off (No yellow showing)

465 Control Settings (*Indicates Changes From Previous Step)

Power Controls

Regulating Range Selector	Medium
Line Voltage Selector	115 V
POWER	ON

CRT Controls

INTENSITY	As desired
FOCUS	Best focused display
SCALE ILLUM	As desired

Vertical Controls (both Channels if applicable)

*VOLTS/DIV	*5 mV
VAR	Calibrated detent

Triggering Controls (both A and B if applicable)

LEVEL	As needed for a stable display
SLOPE	+
COUPLING	AC
SOURCE	NORM
TRIG MODE	AUTO

Sweep Controls

HORIZ DISPLAY	A
DELAY TIME POSITION	Fully counterclockwise
*A TIME/DIV	*1 ms
*B TIME/DIV	*1 ms
VAR TIME/DIV	Calibrated detent
X10 MAG	Off (button out)
POSITION	Midrange
FINE	Midrange
A TRIG HOLDOFF	NORM

1. Check Probe Coding Indicator Lights

a. Connect a X10 Probe with a scale-factor switching connector to the CH 1 input connector (or connect an 11 kilohm resistor between the input coding ring and ground).

b. CHECK—Light under 5 mV position is extinguished and the light under 50 mV position comes on.

c. Set the VERT MODE switch to CH 2.

d. Move the probe, or the 11 kilohm resistor, to the CH 2 input.

e. CHECK—Light under 5 mV position is extinguished and the light under 50 mV position comes on.

f. Remove the X10 probe or the resistor.

2. Check Ch 1 and Ch 2 Gate Current

a. Set:

CH 1 & CH 2 AC-GND-DC	GND
CH 1 & CH 2 VOLTS/DIV	5 mV

b. Position the trace to graticule center.

c. Switch the CH 2 AC-GND-DC switch to DC.

d. CHECK—Trace shift is 0.1 division or less when CH 2 AC-GND-DC switch is switched between GND and DC.

e. Set the VERT MODE switch to CH 1.

f. Position the trace to graticule center.

g. Switch the CH 1 AC-GND-DC switch to DC.

h. CHECK—Trace shift is 0.1 division or less when the CH 1 AC-GND-DC switch is switched between GND and DC.

3. Check AC-GND-DC Switches

a. Connect a 20 millivolt standard amplitude signal from the calibration generator to the CH 1 input via a 50 ohm BNC cable (unterminated).

b. Position the bottom of the display to the center horizontal graticule line.

c. Set the CH 1 AC-GND-DC switch to GND.

d. CHECK—For no vertical deflection; trace is on the center horizontal graticule line.

e. Set the CH 1 AC-GND-DC switch to AC.

f. CHECK—Display is centered about the center horizontal graticule line.

g. Move the test signal to CH 2.

h. Set the VERT MODE switch to CH 2.

i. Position the bottom of the display to the center horizontal graticule line.

j. Set CH 2 INPUT COUPLING switch to GND.

k. CHECK—Display for no vertical deflection; trace is at the center horizontal graticule line.

l. Set the CH 2 INPUT COUPLING switch to AC.

m. CHECK—Display is centered about the center horizontal graticule line.

n. Remove the test setup.

4. Check Alternate Mode

a. Set:

VERT MODE	ALT
A TRIGGER LEVEL	Fully counterclockwise

b. Position the 2 traces about 2 divisions apart.

c. CHECK—Sweeps alternate at all settings of the A TIME/DIV switch except X-Y.

5. Check Chop Mode

a. Set:

A TIME/DIV	1 μ s
VERT MODE	CHOP
AC-GND-DC (Both)	GND

Calibration—465 Service (SN B250000 & up)

- b. Position the 2 traces about 4 divisions apart.
- c. Adjust the A LEVEL control for a stable display.
- d. CHECK—Display for blanking of switching transients between chopped segments.
- e. CHECK—Duration of each cycle is about 4 divisions.

6. Adjust Output Amplifier Bias (IC version only)

NOTE

This adjustment affects position effect, aberrations, and risetime. This adjustment may be slightly misadjusted for optimum vertical performance. Severe misadjustment will result in loss of gain and increased aberrations.

If performing a routine recalibration, do not adjust at this time. Move to step 7 and complete the checks in Steps 7 through 25. If calibration requirements are met there is no need to readjust the bias. If position effect, aberrations and risetime requirements are not met, then readjust the bias according to the procedure in the note after step 25.

Recalibration Due to Replacement of Vertical Output IC.

ADJUST As follows:

- a. Set:

VERT MODE	CH 1
CH 1 VOLTS/DIV	0.2 V
CH 1 AC-GND-DC	DC
- b. Connect the leveled-sine wave generator to the CH 1 input via a 50 ohm BNC cable and 50 ohm BNC termination. Set generator to 50 kHz.
- c. Adjust the leveled sine-wave generator for a few divisions of display.
- d. ADJUST—Vertical Output Bias (R455) for maximum display amplitude.
- e. Disconnect the test setup.

7. Check/Adjust Vertical Output Centering

- a. Set:

VERT MODE	CH 1
CH 1 & CH 2 VOLTS/DIV	5 mV
CH 1 & CH 2 AC-GND-DC	GND
- b. Connect the dc voltmeter between TP322 and TP324.
- c. Adjust the CH 1 POSITION control for 0 volt on the voltmeter.
- d. ADJUST—Vertical Output Centering (R4418) to position the trace to the center graticule line.
- e. Remove the voltmeter lead connections.

8. Check/Adjust Ch 1 Step Attenuator Balance

- a. Set the CH 1 VOLTS/DIV switch to 20 mV.
- b. Position the trace to the center horizontal graticule line.
- c. CHECK—Display for 0.2 division or less of trace shift between adjacent positions when rotating the CH 1 VOLTS/DIV switch from 20 mV to 5 mV.
- d. ADJUST—CH 1 Step Atten Bal (R25) for minimum trace shift when rotating the CH 1 VOLTS/DIV switch from 20 mV to 5 mV.

9. Check/Adjust Ch 1 Variable Volts/Division Balance

- a. Position the trace to the center horizontal graticule line.
- b. CHECK—Display for 1.0 division or less of trace shift when rotating the CH 1 VAR control through its range.
- c. CHECK—CH 1 UNCAL light comes on when the VAR control is out of the detent position.
- d. ADJUST—CH 1 Variable Balance (R120) for minimum trace shift when rotating the CH 1 VAR control through its range.

- e. Return the CH 1 VAR control to the detent position.

10. Check/Adjust Ch 2 Step Attenuator Balance

- a. Set:

VERT MODE	CH 2
CH 2 VOLTS/DIV	20 mV

- b. Position the trace to the center horizontal graticule line.

c. CHECK—Display for 0.2 division or less of trace shift between adjacent switch positions when rotating the CH 2 VOLTS/DIV switch from 20 mV to 5 mV.

d. ADJUST—CH 2 Step Atten Bal (R75) for minimum trace shift when rotating the CH 2 VOLTS/DIV switch from 20 mV to 5 mV.

11. Check/Adjust Ch 2 Variable Volts/Division Balance

a. CHECK—Display for 1.0 division or less of trace shift when rotating the CH 2 VAR control through its range.

b. CHECK—CH 2 UNCAL light comes on when the CH 2 VAR control is out of the detent position.

c. ADJUST—CH 2 Variable Balance (R220) for minimum trace shift when rotating the CH 2 VAR control through its range.

- d. Return the VAR control to the detent position.

12. Check/Adjust Ch 2 Invert Balance

a. Position the trace to the center horizontal graticule line.

- b. Push the INVERT button.

c. CHECK—2 divisions or less of trace shift between INVERT in and INVERT out.

d. ADJUST—Invert Balance (R215) for minimum trace shift between INVERT in and INVERT out.

e. INTERACTION—CH 2 Variable Volts/Division balance.

13. Check/Adjust CH 2 Position Centering

a. Connect the leveled sine-wave generator to the Ch 2 input via a 50 ohm BNC cable and a 50 ohm BNC termination.

- b. Set:

CH 2 INVERT	Button out
CH 2 VOLTS/DIV	0.1 V
CH 2 AC-GND-DC	DC
A TIME/DIV	1 ms
INTENSITY	as needed for a visible display

c. Adjust the leveled sine-wave generator for 4.8 divisions of a 50 kilohertz signal.

d. Set the CH 2 VOLTS/DIV switch to 20 mV (24 divisions of display).

e. CHECK—Display can be positioned both above and below the center horizontal graticule line.

f. ADJUST—Slight readjustment of vertical output centering **R429** (R4418) can be made such that the display can be positioned an equal distance both above and below the center horizontal graticule line.

14. Check/Adjust CH 1 Position Centering

a. Move the leveled sine-wave generator signal to the CH 1 input.

- b. Set:

CH 1 AC-GND-DC	DC
CH 1 VOLTS/DIV	20 mV
VERT MODE	CH 1

c. CHECK—Display can be positioned both above and below the center horizontal graticule line.

d. ADJUST—CH 1 Position Centering (R115) so the display can be positioned an equal distance both above and below the center horizontal graticule line.

e. INTERACTION—CH 1 VAR VOLTS/DIV balance (R120).

Calibration—465 Service (SN B250000 & up)

15. Check Beam Finder Operation

a. Push the BEAM FINDER button and hold it in throughout checks b through d.

b. CHECK—Display remains visible regardless of the settings of the CH 1 POSITION and the HORIZONTAL POSITION controls.

c. CHECK—Display intensity is not affected when the setting of the INTENSITY control is changed.

d. Position the trace to the center horizontal graticule line. Set the HORIZONTAL POSITION control and the INTENSITY control to midrange.

e. Release the BEAM FINDER button and CHECK—Trace remains visible on the screen.

f. Disconnect test equipment.

16. Check/Adjust Ch 1 and Vertical Output Gain

a. Set:

VERT MODE CH 1
 CH 1 & CH 2 AC-GND-DC DC
 CH 1 & CH 2 VOLTS/DIV 5 mV

b. Connect a 20 millivolt standard amplitude signal from the calibration generator to the CH 1 input via a 50 ohm unterminated BNC cable.

c. Connect two X10 probes from the test oscilloscope to TP322 and TP324 on the 465 Preamp board.

d. Set test oscilloscope:

VERT MODE ADD
 CH 2 INVERT Inverted
 CH 1 & CH 2 VOLTS/DIV 50 mV

e. CHECK—Test oscilloscope for a 200 millivolt (peak to peak) signal between TP322 and TP324.

NOTE

This is a nominal value and may vary 10% or more from instrument to instrument.

f. ADJUST—CH 1 Gain (R118) for a 200 millivolt (peak to peak) signal between TP322 and TP324.

g. Remove the X10 probes from TP322 and TP324.

h. CHECK—465 crt display for 4 divisions of deflection.

i. ADJUST—Vertical Output Gain (R4466) R400 for 4 divisions of display.

j. CHECK—Accuracy of all CH 1 VOLTS/DIV ranges according to Table 6-5.

TABLE 6-5

VERTICAL DEFLECTION FACTOR ACCURACY

VOLTS/DIV Switch Setting	Standard Amplitude Output	Vertical Deflection in Divisions
5 m	20 mV	3.88 to 4.12
10 m	50 mV	4.85 to 5.15
20 m	0.1 V	4.85 to 5.15
50 m	0.2 V	3.88 to 4.12
.1	0.5 V	4.85 to 5.15
.2	1 V	4.85 to 5.15
.5	2 V	3.88 to 4.12
1	5 V	4.85 to 5.15
2	10 V	4.85 to 5.15
5	20 V	3.88 to 4.12

17. Check/Adjust Ch 2 Gain

a. Set the VERT MODE switch to CH 2.

b. Adjust the calibration generator for a 20 millivolt output and move this signal to the CH 2 input.

c. CHECK—Display for 4 divisions of deflection.

d. ADJUST—CH 2 Gain (R218) for 4 divisions of deflection.

e. CHECK—Accuracy of all CH 2 VOLTS/DIV ranges according to Table 6-5.

18. Check Ch 1 & Ch 2 Variable Volts/Division Range

a. Set:

CH 1 & CH 2 VOLTS/DIV 10 mV
 Calibration generator
 output 50 mV

Calibration—465 Service (SN B250000 & up)

- b. Rotate the Ch 2 VAR control fully counterclockwise.
- c. CHECK—Display reduces to less than 2 divisions.
- d. Move the test signal to the CH 1 input connector.
- e. Set the VERT MODE switch to CH 1.
- f. Rotate the Ch 1 VAR control fully counterclockwise.
- g. CHECK—Display reduces to less than 2 divisions.
- h. Return the VAR controls to the detent positions.

19. Check Add Mode

a. Connect the calibration generator to both CH 1 & CH 2 via a dual input coupler and adjust for a 10 millivolt output.

b. Set:

VERT MODE	ADD
CH 1 & CH 2 VOLTS/DIV	5 mV

c. CHECK—Display for 3.88 to 4.12 divisions of deflection.

20. Check Compression and Expansion

a. Set:

CH 2 AC-GND-DC	GND
VERT MODE	CH 1

b. Adjust the calibration generator for a 20 millivolt output.

c. Adjust the CH 1 VAR control for exactly 2 divisions of deflection centered about the center horizontal graticule line.

d. Position the top of the display to the top graticule line.

e. CHECK—Display for 0.1 division or less of compression or expansion.

f. Position the bottom of the display to the bottom graticule line.

g. CHECK—Display for 0.1 division or less of compression or expansion.

h. Set the CH 1 VAR control to the detent position.

i. Disconnect the test setup.

21. Check/Adjust Vertical Output Low Frequency Compensation

a. Set:

A TIME/DIV	0.2 ms
CH 1 & CH 2 AC-GND-DC	DC
VERT MODE	CH 1

b. Connect the fast-rise + output of the Square-wave Generator to the CH 1 input via a 50 ohm BNC cable, 10X BNC attenuator, and a 50 ohm BNC termination.

c. Adjust the square-wave generator to maintain a 5 division display throughout this step.

d. Adjust the square-wave generator for a 1 kilohertz signal.

e. CHECK—Display for a flat-top waveform with 3% (0.15 division) or less overshoot or roll off.

f. ADJUST— R424 (IC version only) for the best flat-top waveform.

g. Set:

A TIME/DIV	20 μ s
------------	------------

h. Adjust the square-wave generator for a 10 kilohertz signal.

Calibration—465 Service (SN B250000 & up)

i. CHECK—Display for a flat-top waveform with 3% (0.15 division) or less overshoot or rolloff.

j. ADJUST—R4425 R434 for the best flat-top waveform.

k. Set the A TIME/DIV switch to 2 μ s.

l. Adjust the square-wave generator for a 100 kilohertz signal.

m. CHECK—Display for a flat-top waveform with 3% (0.15 division) or less overshoot or rolloff.

n. ADJUST—R4427 R433, R423 for the best flat-top waveform.

o. INTERACTION—Between all vertical Output Low Frequency adjustments.

22. Check/Adjust Ch 1 Volts/Division Compensation

a. Add a 20 picofarad normalizer to the test setup between the 50 ohm BNC termination and the CH 1 input.

b. Move the test setup from the fast-rise + output to the high-amplitude output of the square-wave generator and adjust the generator for a 1 kilohertz signal. Set A TIME/DIV to .2 ms.

c. Adjust the square-wave generator amplitude for a 5 division display. Add or remove attenuators as necessary to maintain a 5 division display throughout this step.

d. CHECK—Display for a flat-top waveform with 3% or less overshoot or roll-off on the leading edge.

e. ADJUST—C1 with the low-capacitance screwdriver for the best flat-top waveform.

NOTE

If C1 does not have sufficient range C2 can be removed or replaced with a 2 picofarad capacitor. The nominal value is 1 picofarad.

f. Set the CH 1 VOLTS/DIV switch to 50 mV.

g. CHECK—Display for a flat-top waveform with 3%, or less, overshoot or roll-off on the leading edge.

h. ADJUST—Channel 1 C13 for the best flat-top waveform, and Channel 1 C12 for the best front corner with the low-capacitance screwdriver.

i. CAL AID—Remove the 20 picofarad normalizer when adjusting or checking the front corner response.

j. INTERACTION—Between Channel 1's C13 and C12. Readjust both for total optimum response.

k. Set the CH 1 VOLTS/DIV switch to 0.5 V.

l. CHECK—Display for a flat-top waveform with 3% or less overshoot or roll-off on the leading edge.

m. ADJUST—Channel 1 C11 for the best flat-top waveform, and Channel 1 C10 for the best front corner using a low capacitance screwdriver.

n. Set the CH 1 VOLTS/DIV switch to 5 V. It may be necessary to remove the 50 ohm termination to get 5 divisions of display at 5 volts/division.

o. CHECK—Display for a flat-top waveform with 3% or less overshoot or roll-off on the leading edge.

23. Check/Adjust Ch 2 Volts/Division Compensation

a. Set the VERT MODE switch to CH 2.

b. Move the fast-rise + output signal from the CH 1 input to the CH 2 input (through a 50 ohm BNC cable, 10X BNC attenuator, 20 picofarad normalizer and 50 ohm BNC termination).

c. Adjust the square-wave generator for a 5 division display. Add or remove attenuators as necessary to maintain a 5 division display.

d. CHECK—Display for a flat-top waveform with 3% or less overshoot or roll-off on the leading edge.

e. ADJUST—C51 with the low-capacitance screwdriver for the best flat-top waveform.

NOTE

If C51 does not have sufficient range, C52 can be removed or replaced with a 2 picofarad capacitor. The nominal value is 1 picofarad.

NOTE

Steps 24 through 29 are adjustment related. Perform all the checks in each of these steps before making any adjustments (unless calibration is being performed after repair or replacement of vertical components).

- f. Set the CH 2 VOLTS/DIV switch to 50 mV.
- g. CHECK—Display for a flat-top waveform with 3% or less overshoot or roll-off on the leading edge.
- h. ADJUST—Channel 2 C63 for the best flat-top waveform, and Channel 2 C62 for the best front corner with the low-capacitance screwdriver.
- i. CAL AID—Remove the 20 picofarad normalizer when adjusting or checking the front corner response.
- j. INTERACTION—Between Channel 2's C64 and C62. Readjust both for total optimum response.
- k. Set the CH 2 VOLTS/DIV switch to 0.5 V.
- l. CHECK—Display for a flat-top waveform with 3% or less overshoot or roll-off on the leading edge.
- m. ADJUST—Channel 2 C61 for the best flat-top waveform, and Channel 2 C60 for the best front corner with the low-capacitance screwdriver.
- n. INTERACTION—Between Channel 2's C61 and C60. Readjust both for optimum response.
- o. Set the CH 2 VOLTS/DIV switch to 5 V. It may be necessary to remove the 50 ohm BNC termination to get 5 divisions of display at 5 volts/division.
- p. CHECK—Display for a flat-top waveform with 3% or less overshoot or roll-off on the leading edge.
- q. Disconnect the test setup.

24. Check/Adjust Ch 2 and Vertical Output High Frequency Compensation

- a. Set:

CH 1 & CH 2 VOLTS/DIV	5 mV
A TIME/DIV	0.05 μ s
- b. Connect the fast rise, positive output of the square-wave generator to the CH 2 input via a 50 ohm BNC cable, 10X BNC Attenuator and 50 ohm BNC termination.

- c. Adjust the square-wave generator for a 5 division display of a 100 kilohertz signal. Add or remove attenuators as needed to maintain a 5 division display throughout this step.
 - d. CHECK—Display for a flat-top waveform with aberrations of 3% peak-to-peak or less (0.15 division peak-to-peak for a 5 division display).
 - e. CHECK—Display for a risetime of 3.5 nanoseconds or less with X10 MAG on (in).
 - f. ADJUST—C77, C83, C205, R205, C249 and R249 on the Preamp board. Also C4428, R4438, C4422, R4422 on the discrete Vertical Output board. Set X10 MAG on or off as required for best display during adjustment.
- Also C403, C442, R442 and C443 on the IC Vertical Output board.
- Adjust for the best flat-top display with aberrations of 3% peak-to-peak or less and a risetime of 3.5 nanoseconds or less.
 - g. Move the test setup to the fast rise, negative output of the square-wave generator.
 - h. Set the A TRIGGER SLOPE switch to —.
 - i. CHECK—Display for a flat-bottom waveform with aberrations of 5% peak-to-peak or less. (0.25 division peak-to-peak for a 5 division display.)

25. Check Ch 2 Position Effect

- a. Position the bottom of the display to the top horizontal graticule line.
- b. CHECK—Display for a flat-bottom waveform with aberrations of 7% peak-to-peak or less (0.35 division with a 5 division display).
- c. Position the bottom of the display to the bottom horizontal graticule line.

Calibration—465 Service (SN B250000 & up)

d. CHECK—Display for a flat-bottom waveform with aberrations of 7% peak-to-peak or less (0.35 division with a 5 division display).

e. Move the test setup to the Fast rise, positive output of the square-wave generator.

f. Set the A TRIGGER SLOPE switch to +.

g. Position the top of the display to the top horizontal graticule line.

h. CHECK—Display for a flat-top waveform with aberrations of 5% peak-to-peak or less (0.25 division with a 5 division display).

i. Position the top of the display to the bottom horizontal graticule line.

j. CHECK—Display for a flat-top waveform with aberrations of 5% peak-to-peak or less (0.25 division with a 5 division display).

NOTE

If you have trouble with position effect and aberrations, then readjustment of the Vertical Output Bias (R455) could help. Readjust as follows:

Set the VOLTS/DIV switch to 5 mV. Adjust the square-wave generator for 5 divisions of + display. Move the top of the display from the top to the bottom of the graticule area while adjusting the Vertical Output Bias (R455). Adjust R455 for minimum observable change in the flat-top aberrations when moving the display from the top to the bottom of the graticule area.

INTERACTIONS:

Vertical Centering (steps 7, 13 and 14).

Vertical Output Gain (step 16i).

Compression and Expansion (step 20).

Vertical Output Low Frequency Compensation (step 21).

After readjustment for interactions, readjust according to step 24f and repeat the checks in the remainder of step 24 and step 25.

26. Check/Adjust Ch 2 10 mV and 20 mV High Frequency Compensation

a. Set the CH 2 VOLTS/DIV switch to 10 mV.

b. Adjust the square-wave generator for 5 divisions of display.

c. CHECK—Display for a flat-top waveform with aberrations of 3% peak-to-peak or less. (0.15 division with a 5 division display).

d. CHECK—Display for a risetime of 3.5 nanoseconds or less with X10 MAG on (in).

e. ADJUST—R97 and C97 (use low capacitance screw-driver) for the best flat-top waveform with 3% peak-to-peak or less aberrations and a risetime of 3.5 nanoseconds or less.

f. Set the CH 2 VOLTS/DIV switch to 20 mV and X10 MAG off (out).

g. Remove the 10X attenuator and adjust the square-wave generator for a 5 division display.

h. CHECK—Display for a flat-top waveform with aberrations of 3% peak-to-peak or less (0.15 division with a 5 division display).

i. CHECK—Display for a risetime of 3.5 nanoseconds or less with X10 MAG on (in).

j. ADJUST—R98 and C98 (use low capacitance screw-driver) for the best flat-top waveform with 3% peak-to-peak or less aberrations and a risetime of 3.5 nanoseconds or less.

27. Check/Adjust Ch 1 High Frequency Compensation

a. Set the VERT MODE switch to CH 1 and X10 MAG to off (out).

b. Move the test setup from CH 2 to CH 1. Add or remove attenuators as necessary to maintain a 5-division display.

c. Adjust the square-wave generator for 5 divisions of display.

d. CHECK—Display for a flat-top waveform with aberrations of 3% peak-to-peak or less (0.15 division with a 5 division display).

e. CHECK—Display for a risetime of 3.5 nanoseconds or less with X10 MAG on (in).

f. ADJUST—(with low capacitance screwdriver) C27, C33, C105, R105, C122, R122, C149, and R149 for the best flat-top waveform with aberrations of 3% peak-to-peak or less and a risetime of 3.5 nanoseconds or less.

g. Set X10 MAG off (out) and move the test setup to the fast rise, negative output of the square-wave generator.

h. Set the A TRIGGER SLOPE switch to $-$.

i. CHECK—Display for a flat-bottom waveform with aberrations of 5% peak-to-peak or less (0.25 division with a 5 division display).

28. Check Ch 1 Position Effect

a. Position the bottom of the display to the top horizontal graticule line.

b. CHECK—Display for a flat-bottom waveform with aberrations of 7% peak-to-peak or less (0.35 division with a 5 division display).

c. Position the bottom of the display to the bottom horizontal graticule line.

d. CHECK—Display for a flat-bottom waveform with aberrations of 7% peak-to-peak or less (0.35 division with a 5 division display).

e. Move the test setup to the Fast rise, positive output of the square-wave generator.

f. Set the A TRIGGER SLOPE switch to $+$.

g. Position the top of the display to the top horizontal graticule line.

h. CHECK—Display for a flat-top waveform with aberrations of 5% peak-to-peak or less (0.25 division with a 5 division display).

i. Position the top of the display to the bottom horizontal graticule line.

j. CHECK—Display for a flat-top waveform with aberrations of 5% peak-to-peak or less (0.25 division with a 5 division display).

29. Check/Adjust Ch 1 10 mV and 20 mV High Frequency Compensation

a. Set the CH 1 VOLTS/DIV switch to 10 mV.

b. Adjust the square-wave generator for 5 divisions of display. Add or remove attenuators as needed to maintain a 5-division display.

c. CHECK—Display for a flat-top waveform with aberrations of 3% peak-to-peak or less (0.15 division with a 5 division display).

d. CHECK—Display for a risetime of 3.5 nanoseconds or less with X10 MAG on (in).

e. ADJUST—R47 and C47 for the best flat-top waveform with 3% peak-to-peak or less aberrations and a risetime of 3.5 nanoseconds or less.

f. Set the CH 1 VOLTS/DIV switch to 20 mV and X10 MAG to off (out).

g. Adjust the square-wave generator for 5 divisions of display.

h. CHECK—Display for a flat-top waveform with aberrations of 3% peak-to-peak or less (0.15 division with a 5 division display).

i. CHECK—Display for a risetime of 3.5 nanoseconds or less with X10 MAG on (in).

j. ADJUST—R48 and C48 for the best flat-top waveform with 3% peak-to-peak or less aberrations and a risetime of 3.5 nanoseconds or less.

k. Remove the test setup.

30. Check Bandwidth

a. Set:

A TIME/DIV	5 μ s
A TRIGGER LEVEL	Fully clockwise (un-triggered display)
CH 1 & CH 2 VOLTS/DIV	5 mV

b. Connect the leveled sine-wave generator to the CH 1 input via a 50 ohm BNC cable, X10 BNC attenuator and a 50 ohm BNC termination.

Calibration—465 Service (SN B250000 & up)

c. Adjust the sine-wave generator for a 5 division display of a reference signal of about 50 kilohertz.

d. Set the generator to 100 megahertz. Do not change the generator amplitude adjustment.

e. CHECK—Display amplitude is 3.5 divisions or more.

f. Repeat steps c through e for all CH 1 VOLTS/DIV ranges from 10 mV to 1 V (remove 10X attenuator as necessary).

g. Set:

VERT MODE	CH 2
CH 2 VOLTS/DIV	5 mV

h. Move the test setup to the CH 2 input.

i. Repeat steps c through e for all CH 2 VOLTS/DIV ranges from 5 mV to 1 V (remove 10X attenuator as necessary).

31. Check Cascaded Gain and Bandwidth

a. Set:

CH 1 & CH 2 VOLTS/DIV	5 mV
A TIME/DIV	1 ms

b. Connect the CH 1 VERT SIGNAL OUT (on the rear panel) to the CH 2 input connector via a 50 ohm BNC cable and a 50 ohm BNC termination.

c. Connect a 5 millivolt standard amplitude signal from the calibration generator to the CH 1 input via a 50 ohm unterminated BNC cable.

d. CHECK—Display for at least 5 divisions of deflection.

e. Remove the standard amplitude signal from the CH 1 input.

f. Connect the output of the leveled sine-wave generator to the CH 1 input via a 50 ohm BNC cable, 10X BNC attenuator, and a 50 ohm BNC termination.

g. Adjust the leveled sine-wave generator for a 5 division display of a 50 kilohertz reference signal.

h. Adjust the leveled sine-wave generator for 50 megahertz. Do not change the generator amplitude adjustment.

i. CHECK—Display for an amplitude of 3.5 divisions or greater.

j. Disconnect the test setup.

32. Check Channel Isolation

a. Set:

CH 2 VOLTS/DIV	0.2 V
CH 1 AC-GND-DC	GND

b. Connect the leveled sine-wave generator to the CH 2 input via a 50 ohm BNC cable and a 50 ohm BNC termination.

c. Adjust the leveled sine-wave generator for a 2 division display of a 25 megahertz signal.

d. Set:

CH 1 & CH 2 VOLTS/DIV	20 mV (20 divisions of display in CH 2)
VERT MODE	CH 1

e. CHECK—Display for no more than 0.2 division of deflection (100:1 ratio).

f. Move the CH 2 input test setup to the CH 1 input.

g. Set:

CH 2 AC-GND-DC	GND
CH 1 AC-GND-DC	DC
VERT MODE	CH 2

h. CHECK—Display for no more than 0.2 division of deflection.

33. Check Common-Mode Rejection Ratio

a. Set:

CH 1 & CH 2 VOLTS/DIV	5 mV
CH 1 & CH 2 AC-GND-DC	DC
VERT MODE	CH 1
CH 2 INVERT	Inverted (pushed in)

b. Connect a 20 megahertz signal from the leveled sine-wave generator to the CH 1 and CH 2 inputs via a 50 ohm BNC cable, X10 BNC attenuator, 50 ohm BNC termination and dual-input coupler.

c. Set the generator for a 6 division display.

d. Set the VERT MODE switch to ADD.

e. CHECK—Display is 0.6 division or less (indicates cmrr of at least 10:1 at 20 megahertz).

f. If cmrr in part e is not at least 10:1, recheck steps 16 through 20 and all of step 33.

g. Set the CH 2 INVERT switch to normal (button out).

34. Check Bandwidth Limit Operation

a. Set:

20 MHz BW (PULL)	Pull out (shows yellow)
CH 1 AC-GND-DC	DC
VERT MODE	CH 1

b. Adjust the leveled sine-wave generator for 6 divisions of a 50 kilohertz reference signal.

c. Increase the generator output frequency until the display amplitude is 4.2 divisions.

d. CHECK—Generator output frequency is between 16 and 24 megahertz.

e. Disconnect the test setup.

TRIGGERS

Equipment Required

- | | |
|-------------------------------------------|-----------------------------------------|
| 1. Leveled Sine-wave Generator | 8. GR-to-BNC-Female Adapter |
| 2. Low-frequency Generator | 9. GR-to-BNC-Male Adapter |
| 3. Time Mark Generator | 10. 10X BNC Attenuator |
| 4. Calibration Generator | 11. 50 ohm BNC Termination (2 required) |
| 5. 50 ohm Signal Pickoff Unit (Type CT-3) | 12. Dual-input Coupler (2 required) |
| 6. 10X Probe | 13. BNC T Connector |
| 7. 42 Inch BNC Cable (2 required) | 14. 3 Inch slotted Screwdriver |

See **ADJUSTMENT LOCATIONS 2** and **ADJUSTMENT LOCATIONS 4** in the *Diagrams* section for adjustments and test points (TP).

465 Control Settings (*Indicates Change From the Previous Step)

Regulating Range Selector Medium
 Line Voltage Selector 115 V
 POWER ON

CRT Controls

INTENSITY As desired
 FOCUS Best focused display
 SCALE ILLUM As desired

Vertical Controls (both channels if applicable)

*VOLTS/DIV *10 mV
 VAR Calibrated detent
 POSITION Midrange
 AC-GND-DC DC
 VERT MODE CH 1
 INVERT Off (Button out)
 *20 MHz BW (Pull) *Off (No yellow showing)

Triggering Controls (both A and B if applicable)

LEVEL Adjust as needed for a stable display
 SLOPE +
 COUPLING AC
 SOURCE NORM
 TRIG MODE AUTO

Sweep Controls

HORIZ DISPLAY A
 DELAY TIME POSITION Fully counterclockwise
 *A TIME/DIV *0.05 μ s
 *B TIME/DIV *0.05 μ s
 VAR TIME/DIV Calibrated detent
 X10 MAG Off (button out)
 POSITION Midrange
 FINE Midrange
 A TRIG HOLDOFF NORM

1. Check/Adjust A Trigger Sensitivity and Triggered Lamp

a. Connect a 25 megahertz signal from the leveled sine-wave generator to the A and B external trigger inputs via a GR-to-BNC-male adapter, CT-3 through output, GR-to-BNC-female adapter, 50 ohm BNC cable, 10X BNC Attenuator, 50 ohm BNC termination and dual input coupler.

b. Connect CT-3 Sig Out 10% signal to CH 1 and CH 2 inputs via a 50 ohm BNC cable, 50 ohm BNC termination and a dual input coupler.

c. Adjust the leveled sine-wave generator for 3 divisions of display.

d. Set the CH 1 VOLTS/DIV switch to 0.1 V (0.3 division of display).

Calibration—465 Service (SN B250000 & up)

e. CHECK—A stable display can be obtained by rotating the A TRIGGER LEVEL control in both + and – slopes.

CHECK—TRIG lamp is on when the display is stable.

f. Set the CH 1 VOLTS/DIV switch to 5 mV and adjust the leveled sine-wave generator for 2 divisions of display.

g. Set the CH 1 VOLTS/DIV switch to 0.1 V (0.1 division of display).

h. CHECK—Stable display cannot be obtained by rotating the A TRIGGER LEVEL control in both + and – slopes. Return the A Slope control to +.

i. If the CHECKS in steps c through h meet the requirements, move on to step 2. If not, make the following ADJUSTMENTS.

j. Set the CH 1 VOLTS/DIV switch to 10 mV and adjust the leveled sine-wave generator for 2.5 divisions of display.

k. Set the CH 1 VOLTS/DIV switch to 0.1 V (0.25 division of display).

l. ADJUST—A Trigger Sensitivity (R655) so the display can just be triggered by rotating the A TRIGGER LEVEL control (Adjust with A Slope +).

m. Set the CH 1 VOLTS/DIV switch to 10 mV and adjust the leveled sine-wave generator for 2 divisions of display.

n. Set the CH 1 VOLTS/DIV switch to 0.1 V (0.2 division of display).

o. CHECK—Stable display cannot be obtained by adjusting the A TRIGGER LEVEL control in + slope only (– slope is generally slightly more sensitive).

If a stable display can be obtained, then the trigger is too sensitive.

READJUST—A Trigger Sensitivity slightly so that the display will just barely not trigger by adjusting the A TRIGGER LEVEL control (in + slope only).

p. Repeat steps j through o until a stable display can be obtained on 0.25 division of display, but not on 0.2 division of display (in the + slope only).

q. Repeat the CHECKS in steps c through h.

2. Check/Adjust B Trigger Sensitivity

a. Set:

HORIZ DISPLAY	B DLY'D
CH 1 VOLTS/DIV	10 mV
A TRIGGER LEVEL	Fully clockwise
B TRIGGER LEVEL	As needed for a stable display

b. Adjust the leveled sine-wave generator for 3 divisions of display.

c. Set the CH 1 VOLTS/DIV switch to 0.1 V (0.3 division of display).

d. CHECK—Stable display can be obtained by rotating the B TRIGGER LEVEL control in both + and – slopes.

e. Set the CH 1 VOLTS/DIV switch to 5 mV and adjust the sine-wave generator for 2 divisions of display.

f. Set the CH 1 VOLTS/DIV switch to 0.1 V (0.1 division of display).

g. CHECK—Stable display cannot be obtained by rotating the B TRIGGER LEVEL control in both + and – slopes. Return B SLOPE control to +.

h. If the CHECKS in steps b through g meet the requirements, move on to step 3. If not, make the following ADJUSTMENTS.

i. Set the CH 1 VOLTS/DIV switch to 10 mV and adjust the leveled sine-wave generator for 2.5 divisions of display.

j. Set the CH 1 VOLTS/DIV switch to 0.1 V (0.25 division of display).

k. ADJUST—B Trigger Sensitivity (R555) so the display can be just triggered by adjusting the B TRIGGER LEVEL control. (Adjust with B SLOPE in +).

Calibration—465 Service (SN B250000 & up)

l. Set the CH 1 VOLTS/DIV switch to 10 mV and adjust the leveled sine-wave generator for 2 divisions of display.

m. Set the CH 1 VOLTS/DIV switch to 0.1 V (0.2 division of display).

n. CHECK—Stable display cannot be obtained by adjusting the B TRIGGER LEVEL control in + slope only.

If a stable display can be obtained, then the trigger is too sensitive.

READJUST—B trigger Sensitivity (R555) so that the display will just barely not trigger by adjusting the B TRIGGER LEVEL control in + slope only.

o. Repeat steps i through n until a stable display can be obtained on 0.25 division of display but not on 0.2 division of display (in + slope only).

p. Repeat CHECKS in steps c through g.

3. Check/Adjust B Trigger Slope and Level Centering

a. Set:

B TRIGGER SOURCE	STARTS AFTER DELAY
A & B TIME/DIV	10 μ s
B TRIG LEVEL	0
CH 1 VOLTS/DIV	10 mV
CH 1 AC-GND-DC	GND

NOTE

The B TRIGGER LEVEL control must remain at 0 throughout step 3.

b. Position the trace to the center horizontal graticule line.

c. Set:

CH 1 AC-GND-DC	DC
B TRIGGER SOURCE	NORM

d. Adjust the leveled sine-wave generator for about 4 divisions of display of a 50 kilohertz signal.

e. Switch the B TRIGGER SLOPE switch between + and -.

CHECK—Display begins at about the same vertical point, within 1 division of graticule center, in both + and - slopes.

f. ADJUST—B Slope Center (R545) for the display to start at the same vertical point on the sine-wave (not necessarily the center horizontal graticule line). Return slope to +.

g. ADJUST—B Level Center (R535) to move the starting point of the display to the center horizontal graticule line.

4. Check/Adjust A Trigger Slope and Level Centering

a. Set:

HORIZ MODE	A
A TRIG LEVEL	0

NOTE

The A TRIGGER LEVEL control must remain at 0 throughout step 4.

b. Switch the A TRIGGER SLOPE switch between + and -.

c. CHECK—Display begins at about the same vertical point, within 1 division of graticule center, in both + and - slopes.

d. ADJUST—A Slope Center (R645) for the display to start at the same vertical point on the sine-wave (not necessarily the graticule center) in both + and - slopes. Return A SLOPE to +.

e. ADJUST—A Level Center (R635) to move the starting point of the display to the center horizontal graticule line.

5. Check/Adjust A Trigger DC Levels

a. Set the A COUPLING switch to DC.

NOTE

The A TRIGGER LEVEL control must remain at 0 throughout step 5.

b. CHECK—Start of the display is within 1 division of the center horizontal graticule line in both + and – slopes. Return A SLOPE to +.

c. ADJUST—Normal Trigger DC Balance (R340) to move the starting point of the display to the center horizontal graticule line.

d. INTERACTION—A + B LEVEL centering (R635 and R535).

e. Set the A SOURCE switch to CH 1.

f. CHECK—Start of the display is within 1 division of the center horizontal graticule line in both + and – slopes. Return A SLOPE to +.

g. ADJUST—CH 1 Trigger DC Balance (R155) to move the starting point of the display to the center horizontal graticule line.

h. Set the A SOURCE switch to CH 2.

i. CHECK—Start of the display is within 1 division of the center horizontal graticule line in both + and – slopes. Return A SLOPE to +.

j. ADJUST CH 2 Trigger DC Balance (R255) to move the starting point of the display to the center horizontal graticule line.

6. Check B Trigger DC Levels

a. Set:

HORIZ DISPLAY	B DLY'D
A TRIG LEVEL	Fully clockwise
B TRIG LEVEL	0
B COUPLING	DC
B SOURCE	NORM

NOTE

The B TRIGGER LEVEL control must remain at 0 during step 6.

b. CHECK—Start of the display is within 1 division of the center horizontal graticule line for the following B SOURCE switch positions:

NORM
CH 1
CH 2

7. Check B Internal 25 Megahertz Triggering

a. Set:

A & B TRIGGER COUPLING	AC
CH 1 VOLTS/DIV	10 mV
CH 2 VOLTS/DIV	0.1 V
A TIME/DIV	0.2 μ s
B TIME/DIV	0.05 μ s
A & B SOURCE	NORM

b. Adjust the leveled sine-wave generator for 3 divisions (30 millivolts) of a 25 megahertz display.

c. Set the CH 1 VOLTS/DIV switch to 0.1 V (0.3 division of display).

d. Adjust the B LEVEL control as needed for a stable display.

e. CHECK—For a stable display, with both + and – slopes for these modes:

B TRIGGER

SOURCE	COUPLING
NORM	AC, DC
CH 1	DC, AC
CH 2	AC, DC

f. Set:

CH 1 VOLTS/DIV	10 mV
B TRIGGER COUPLING	LF REJ

g. Adjust the leveled sine-wave generator for 5 divisions (50 millivolts) of a 25 megahertz display.

h. Set the CH 1 VOLTS/DIV switch to .1 V (0.5 division of display).

i. Adjust B LEVEL control as needed for a stable display.

j. CHECK—For a stable display, with both + and – slopes for these modes:

B TRIGGER SOURCE

CH 2
CH 1
NORM

Calibration—465 Service (SN B250000 & up)

- k. Set the B TRIGGER COUPLING switch to HF REJ.
- l. CHECK—No stable display for these modes:

B TRIGGER SOURCE

NORM
CH 1
CH 2

8. Check A Internal 25 Megahertz Triggering

a. Set:

HORIZ DISPLAY	A
A TIME/DIV	.05 μ s
A TRIG LEVEL	As needed for a stable display
CH 1 VOLTS/DIV	10 mV

b. Adjust the leveled sine-wave generator for 3 divisions (30 millivolts) of a 25 megahertz display.

c. Set the CH 1 VOLTS/DIV switch to .1 V (0.3 division of display).

d. Adjust the A LEVEL control as needed for a stable display.

e. CHECK—For a stable display, with both + and – slopes for these modes:

A TRIGGER

SOURCE	COUPLING
NORM	AC, DC
CH 1	DC, AC
CH 2	AC, DC

f. Set:

CH 1 VOLTS/DIV	10 mV
A TRIGGER COUPLING	LF REJ

g. Adjust the leveled sine-wave generator for 5 divisions (50 millivolts) of a 25 megahertz display.

h. Set the CH 1 VOLTS/DIV switch to .1 V (0.5 division of display).

i. Adjust the A LEVEL control as needed for a stable display.

j. CHECK—Stable display, with both + and – slopes for these modes:

A TRIGGER SOURCE

CH 2
CH 1
NORM

k. Set the A TRIGGER COUPLING switch to HF REJ.

l. CHECK—No stable display for these modes:

A TRIGGER SOURCE

NORM
CH 1
CH 2

9. Check A External 25 Megahertz Triggering

a. Set:

CH 1 & CH 2 VOLTS/DIV	10 mV
A & B TRIGGER COUPLING	AC
A & B TRIGGER SOURCE	EXT

b. Adjust the leveled sine-wave generator to maintain 5 divisions of display throughout Steps 9 and 10. Adjust the A LEVEL control as needed for a stable display.

CHECK—For a stable display, with both + and – slopes for these modes:

A TRIGGER COUPLING

AC, DC

c. Set:

CH 1 VOLTS/DIV	20 mV
A TRIGGER COUPLING	LF REJ

d. Adjust the leveled sine-wave generator for 5 divisions (100 millivolts) of a 25 megahertz display.

e. Adjust the A LEVEL control as needed for a stable display.

f. CHECK—Stable display, with both + and – slopes.

- g. Set the A TRIGGER COUPLING switch to HF REJ.
- h. CHECK—No stable display.
- i. Remove the X10 BNC attenuator from the external trigger setup and change the A TRIGGER SOURCE switch to EXT ÷ 10.
- j. CHECK—No stable display.
- k. Set the A TRIGGER COUPLING switch to LF REJ.
- l. CHECK—Stable display, with both + and – slopes.

m. Set:

CH 1 VOLTS/DIV	10 mV
A TRIGGER COUPLING	AC

n. Adjust the leveled sine-wave generator for 5 divisions (50 millivolts) of a 25 megahertz display. (0.5 volt at the external Trigger Input).

o. CHECK—Stable display, with both + and – slopes for these modes:

A TRIGGER COUPLING

AC, DC

10. Check B External 25 Megahertz Triggering

a. Set:

HORIZ DISPLAY	B DLY'D
A TIME/DIV	.2 μ s
B TIME/DIV	0.05 μ s

b. Reconnect the X10 BNC attenuator to the external trigger setup.

c. CHECK—Stable display, with both + and – slopes for these modes:

B TRIGGER COUPLING

AC, DC

d. Set the CH 1 VOLTS/DIV switch to 20 mV.

e. Adjust the leveled sine-wave generator for 5 divisions (100 millivolts) of a 25 megahertz display.

f. Set the B TRIGGER COUPLING switch to LF REJ and adjust the B LEVEL control as needed for a stable display.

g. CHECK—Stable display, with both + and – slopes.

h. Set the B TRIGGER COUPLING switch to HF REJ.

i. CHECK—No stable display.

11. Check B and A External 100 Megahertz Triggering

a. Set:

A & B TRIGGER COUPLING	AC
A & B TRIGGER SOURCE	EXT
CH 1 VOLTS/DIV	50 mV

c. Adjust the leveled sine-wave generator for 3 divisions (150 millivolts) of a 25 megahertz display, then change the frequency to 100 megahertz. Do not readjust signal amplitude.

d. Push in the X10 MAG (IN) button and use the A and B LEVEL controls as needed for a stable display.

e. CHECK—Stable display, with 0.1 division or less jitter, with + and – slopes for these modes:

B TRIGGER COUPLING

AC, DC

f. Adjust the leveled sine-wave generator for 6 divisions (300 millivolts) of a 25 megahertz display, then change the frequency to 100 megahertz. Do not readjust the signal amplitude.

g. Set the B TRIGGER COUPLING switch to LF REJ and use the A and B LEVEL controls as needed.

h. CHECK—Stable display, with 0.1 division or less jitter, with both + and – slopes.

i. Set the B TRIGGER COUPLING switch to HF REJ.

CHECK—No stable display.

Calibration—465 Service (SN B250000 & up)

j. Set:

HORIZ DISPLAY A
 A TIME/DIV .05 μ s
 A TRIGGER MODE LF REJ
 A TRIGGER SOURCE EXT

k. Use the A LEVEL control as needed.

l. CHECK—Stable display, with 0.1 division or less jitter, with both + and - slopes.

m. Set the A TRIGGER COUPLING switch to HF REJ.

n. CHECK—No stable display.

o. Set the A TRIGGER COUPLING switch to AC.

p. Adjust the leveled sine-wave generator for 3 divisions (150 millivolts) of a 25 megahertz display, then change the frequency to 100 megahertz. Do not readjust the signal amplitude.

q. Use the A LEVEL control as needed for a stable display.

r. CHECK—Stable display, with 0.1 division or less jitter, with both + and - slopes:

A TRIGGER COUPLING

AC, DC

s. Remove the X10 BNC attenuator from the external trigger setup and change the A TRIGGER SOURCE switch to EXT \div 10.

t. Use the A LEVEL control as needed for a stable display.

u. CHECK—Stable display, with 0.1 division or less jitter, with both + and - slopes for these modes:

A TRIGGER COUPLING

DC, AC

v. Adjust the leveled sine-wave generator for 6 divisions (300 millivolts) of a 25 megahertz display, then change the frequency to 100 megahertz. Do not readjust the signal amplitude.

w. Set the A TRIGGER COUPLING switch to LF REJ and use the A LEVEL control as needed for a stable display.

x. CHECK—Stable display, with 0.1 division or less jitter, with both + and - slopes.

y. Set the A TRIGGER COUPLING switch to HF REJ.

z. CHECK—No stable display.

12. Check A Internal 100 Megahertz Triggering

a. Set:

CH 1 & CH 2 VOLTS/DIV 50 mV
 A & B TRIGGER SOURCE NORM
 A & B TRIGGER COUPLING AC

b. Reconnect the X10 attenuator to the external trigger setup. Adjust the leveled sine-wave generator for 1.5 divisions of a 100 megahertz display.

c. CHECK—Stable display, with 0.1 division or less jitter, with + and - slopes for these modes:

A TRIGGER

SOURCE	COUPLING
NORM	AC, LF REJ, DC
CH 1	DC, LF REJ, AC
CH 2	AC, LF REJ, DC

d. Set the A TRIGGER COUPLING switch to HF REJ.

e. CHECK—No stable display.

13. Check B Internal 100 Megahertz Triggering

a. Set:

HORIZ DISPLAY B DLY'D
 A TIME/DIV .2 μ s
 B TIME/DIV .05 μ s
 A TRIGGER COUPLING DC
 A TRIGGER SOURCE NORM

b. CHECK—Stable display, with 0.1 division or less jitter, with + and - slopes, for these modes:

B TRIGGER

SOURCE	COUPLING
NORM	AC, LF REJ, DC
CH 1	DC, LF REJ, AC
CH 2	AC, LF REJ, DC

NOTE

It may be necessary to adjust both A and B LEVEL controls to obtain the most stable display at higher frequencies in B sweep.

c. Set the B TRIGGER COUPLING switch to HF REJ.

d. CHECK—No stable display.

14. Check A and B High Frequency Reject TrIGGERING

a. Set:

HORIZ DISPLAY	A
A & B TIME/DIV	10 μ s
X10 MAG	Off (button out)
A & B TRIGGER COUPLING	HF REJ
A & B TRIGGER SOURCE	NORM
CH 1 VOLTS/DIV	.1 V
CH 2 VOLTS/DIV	10 mV
VERT MODE	CH 2

b. Adjust the leveled sine-wave generator for 5 divisions (50 millivolts) of a 50 kilohertz display.

c. Set the CH 2 VOLTS/DIV switch to .1 V. Adjust the A LEVEL control for a stable display.

d. Adjust the leveled sine-wave generator for 1 megahertz and push in the X10 MAG (IN) button.

e. CHECK—No stable display with the A TRIGGER SOURCE switch in NORM, CH 1 or CH 2.

g. Set:

A TRIGGER LEVEL	Fully clockwise
HORIZ DISPLAY	B DLY'D

h. CHECK—No stable display with the B TRIGGER SOURCE switch in NORM, CH 1 or CH 2.

15. Check Single Sweep

a. Set:

A TRIGGER COUPLING	AC
A SOURCE	NORM
A LEVEL	0
A SLOPE	+
HORIZ DISPLAY	A
CH 1 VOLTS/DIV	50 mV
VERT MODE	CH 1
X10 MAG (IN)	Off (button out)

b. Adjust the leveled sine-wave generator for 1 division of a 50 kilohertz display and adjust the A LEVEL control so the display is just triggered.

c. Set:

A & B TIME/DIV	10 ms
CH 1 AC-GND-DC	GND
TRIG MODE	SINGL SWP (push in)

d. CHECK—Ready lamp lights.

e. Set the CH 1 AC-GND-DC switch to DC.

f. CHECK—A single sweep occurs and the READY lamp goes out.

g. Press the SINGL SWP button.

h. CHECK—A single sweep occurs each time the SINGL SWP button is pressed.

i. Remove the test setup.

16. Check 60 Hertz Internal TrIGGERING

a. Set:

A & B TIME/DIV	5 ms
TRIGGER MODE	NORM
CH 1 VOLTS/DIV	10 mV

b. Connect the low-frequency generator signal to the CH 1 input via a 50 ohm BNC cable, BNC tee and 50 ohm BNC termination.

Calibration—465 Service (SN B250000 & up)

From BNC tee, connect a 50 ohm BNC cable and 50 ohm BNC termination to the B EXT input.

c. Adjust the low-frequency generator for 3 divisions (30 millivolts) of a 60 hertz display.

d. Set the CH 1 VOLTS/DIV switch to .1 V (0.3 division of display).

e. CHECK—Stable display, with both + and – slopes for these modes:

A TRIGGER COUPLING

AC, DC

f. Set:

CH 1 VOLTS/DIV	10 mV
A TRIGGER COUPLING	HF REJ

g. Set the low-frequency generator for 5 divisions (50 millivolts) of a 60 hertz display.

h. Set the CH 1 VOLTS/DIV switch to 0.1 V (0.5 division of display).

i. CHECK—Stable display, with both + and – slopes.

j. Set the A TRIGGER COUPLING switch to LF REJ.

k. CHECK—No stable display.

l. Set:

A TRIG MODE	AUTO
A LEVEL	Fully clockwise
A TIME/DIV	10 ms
B TIME/DIV	5 ms
B TRIGGER SOURCE	NORM
B TRIGGER COUPLING	HF REJ
HORIZ DISPLAY	B DLY'D
CH 1 VOLTS/DIV	.1 V

m. CHECK—Stable display, with both + and – slopes.

n. Set the B TRIGGER COUPLING switch to LF REJ.

o. CHECK—No stable display.

p. Set:

CH 1 VOLTS/DIV	10 mV
B TRIG COUPLING	AC

q. Set the low-frequency generator for 3 divisions (30 millivolts) of a 60 hertz display.

r. Set the CH 1 VOLTS/DIV switch to 0.1 V and use the B LEVEL control as needed for a stable display.

s. CHECK—Stable display, with both + and – slopes for these modes.

B TRIGGER COUPLING

AC, DC

17. Check 60 Hertz External Triggering

a. Set:

B TRIGGER COUPLING	AC
CH 1 VOLTS/DIV	10 mV

b. Adjust the low-frequency generator for 5 divisions (50 millivolts) of a 60 hertz display.

c. Set the B TRIGGER SOURCE switch to EXT.

d. CHECK—Stable display, with both + and – slopes for these modes:

B TRIGGER COUPLING

AC, HF REJ, DC

e. Set the B TRIGGER COUPLING switch to LF REJ.

f. CHECK—No stable display.

g. Move the signal cable from the B EXT input to the A EXT input.

h. Set:

HORIZ DISPLAY	A
A TIME/DIV	5 ms
A TRIGGER COUPLING	AC
A TRIG MODE	NORM
A SOURCE	EXT
A TRIGGER LEVEL	As needed

Calibration—465 Service (SN B250000 & up)

i. CHECK—Stable display, with both + and – slopes for these modes:

A TRIGGER COUPLING

AC, HF REJ, DC

j. Set the A TRIGGER COUPLING switch to LF REJ.

k. CHECK—No stable display.

18. Check A and B External Trigger Level Ranges

a. Set:

A & B TRIG COUPLING	AC
A & B TRIG SLOPE	+
CH 1 VOLTS/DIV	1 V
HORIZ MODE	A
A TRIG MODE	AUTO
A TIME/DIV	1 ms

b. Remove the 50 ohm termination and adjust the low frequency generator for 4 divisions (4 volts) of a 1 kilohertz display.

c. CHECK—Display is triggered along the positive slope of the waveform as the A TRIG LEVEL control is rotated.

d. CHECK—Display is not triggered (free runs) at both extremes of rotation.

e. Set the A TRIG SLOPE switch to –.

f. CHECK—Display is triggered along the negative slope of the waveform as the A TRIG LEVEL control is rotated.

g. CHECK—Display is not triggered (free runs) at both extremes of rotation.

h. Move the low frequency generator signal from the A EXT TRIGGER input to the B EXT TRIGGER input.

i. Set:

A TRIG LEVEL	Fully counterclockwise
HORIZ DISPLAY	B DLY'D

j. CHECK—Display is triggered along the positive slope of the waveform as the B TRIG LEVEL control is rotated.

k. CHECK—Display is not triggered (not visible) at both extremes of rotation.

l. Set the B TRIG SLOPE switch to –.

m. CHECK—Display is triggered along the negative slope of the waveform as the B TRIG LEVEL control is rotated.

n. CHECK—Display is not triggered (not visible) at both extremes of rotation.

o. Disconnect the test setup.

p. Set:

HORIZ MODE	A
A TRIG SOURCE	EXT \div 10
CH 1 VOLTS/DIV	5 V
CH 1 VAR	Fully counterclockwise
A COUPLING	AC

q. Connect a 50 volt standard amplitude signal from the calibration generator to the CH 1 input and the A EXT input via a 50 ohm BNC cable, BNC tee to CH 1 input, BNC cable from BNC tee to A EXT input.

NOTE

The range of the A LEVEL control with the A SOURCE switch in EXT \div 10, is ± 20 volts (40 V peak-to-peak) or greater. The applied signal is 50 volts peak-to-peak. Therefore, untriggered operation at both extremes of the A LEVEL control is not required.

r. CHECK—Display is triggered along the negative slope of the waveform as the A LEVEL control is rotated.

s. Set the A SLOPE switch to +.

t. CHECK—Display is triggered along the positive slope of the waveform as the A LEVEL control is rotated.

u. Disconnect the test setup.

19. Check Line Triggers

a. Set:

A TRIGGER MODE	AUTO
A TRIGGER COUPLING	AC
A TRIGGER SOURCE	LINE
SLOPE	+
CH 1 VOLTS/DIV and VAR	As required

Calibration—465 Service (SN B250000 & up)

b. Connect a 10X probe from the CH 1 input to a line-frequency source.

CHECK—Stable display, starting on the positive-going slope.

c. Set the A TRIGGER SOURCE switch to —.

CHECK—Stable display, starting on the negative-going slope.

d. Disconnect probe from the line-frequency source, then from the 465.

20. Check A Normal Mode

a. Set:

A TIME/DIV	1 ms
A SLOPE	+
A TRIGGER SOURCE	NORM
A TRIGGER COUPLING	AC
A TRIGGER MODE	AUTO
CH 1 VOLTS/DIV	.5 V
CH 1 VAR	Calibrated detent

b. Connect 0.1 second time marks from the time-mark generator to the CH 1 input via a 50 ohm BNC cable and 50 ohm BNC termination.

c. CHECK—Display can be triggered by adjusting the A LEVEL control.

d. Set the A TRIG MODE switch to NORM.

e. CHECK—Display is triggered.

f. Set the CH 1 AC-GND-DC switch to GND.

g. CHECK—No display is visible.

21. Check Auto Recovery Time

a. Set:

CH 1 AC-GND-DC	DC
A TRIG MODE	AUTO

b. CHECK—Display is triggered.

c. Set the time-mark generator for 0.5 second time marks.

d. CHECK—Display cannot be triggered (free runs).

e. Disconnect the time-mark generator.

22. Check/Adjust Trigger View Centering

a. Set:

A TRIG COUPLING	AC
SOURCE	EXT
LEVEL	0
A TIME/DIV	.2 ms

b. Connect a 0.2 volt standard amplitude signal from the calibration generator to the A EXT trigger input via a 50 ohm BNC cable.

c. Push the TRIG VIEW button and hold it in.

d. CHECK—Display triggers symmetrically within 1 division of the graticule center line when the A TRIGGER SLOPE switch is switched between + and —.

e. ADJUST—Trig View Centering (R675) to center the display about the center horizontal graticule line.

f. Rotate the A LEVEL control (with the TRIG VIEW button pushed in).

g. CHECK—Display top and bottom are triggered within 1 division of the graticule center line.

h. Set the A TRIG COUPLING switch to DC.

i. Repeat parts f and g.

23. Check Trigger View Gain

a. Push the TRIG VIEW button and hold it in.

b. CHECK—Display amplitude is 3.2 to 4.8 divisions.

c. Disconnect the calibration generator.

IMPORTANT NOTE

OSCILLOSCOPES WITH DIGITAL MULTIMETERS ATTACHED, REFER TO THE CALIBRATION SECTION OF THE DIGITAL MULTIMETER MANUAL AT THIS POINT. ON COMPLETION OF THE CALIBRATION SECTION IN THE DM MANUAL RETURN TO THIS MANUAL AND COMPLETE STEPS 19 & 20 IN THE HORIZONTAL SECTION, THEN CONTINUE ON TO THE NEXT SECTION.

FOR CALIBRATION OF OSCILLOSCOPES WITHOUT DIGITAL MULTIMETERS, CONTINUE TO HORIZONTAL SECTION OF THIS MANUAL.

HORIZONTAL

Equipment Required

- | | |
|--------------------------------|----------------------------------------|
| 1. Test Oscilloscope | 5. 50 ohm BNC Termination |
| 2. Time Mark Generator | 6. 3-Inch slotted Screwdriver |
| 3. 50 ohm BNC Cable | 7. Low Capacitance slotted Screwdriver |
| 4. Leveled Sine-Wave Generator | 8. Dual Input Coupler |

See **ADJUSTMENT LOCATIONS 1** and **ADJUSTMENT LOCATIONS 5** in the Diagrams section for adjustments and test points (TP).

465 Control Settings (*Indicates Change From Previous Step)

Power Controls

Regulating Range Selector Medium
 Line Voltage Selector 115 V
 POWER ON

CRT Controls

INTENSITY As desired
 FOCUS Best focused display
 SCALE ILLUM As desired

Vertical Controls

(both Channels if applicable)

VOLTS/DIV 0.5 V
 VAR Calibrated detent
 POSITION Midrange
 AC-GND-DC DC
 VERT MODE CH 1
 INVERT Off (button out)
 20 MHz BW (Pull) Off (No yellow showing)

**Triggering Controls
 (both A and B if applicable)**

LEVEL As needed for a stable display
 SLOPE +
 *COUPLING *AC
 *A SOURCE *NORM
 *B SOURCE *Starts after delay

Sweep Controls

*HORIZ DISPLAY *A INTEiN
 *DELAY TIME POSITION *1.00
 *A TIME/DIV *1 ms
 *B TIME/DIV *5 μs
 VAR TIME/DIV Calibrated detent
 X10 MAG Off (button out)
 POSITION Midrange
 FINE Midrange
 A TRIG HOLDOFF NORM

1. Check/Adjust Sweep Start and A Sweep Calibration

a. Connect 1 millisecond time marks to the CH 1 input from the time mark generator via a 50 ohm BNC cable and a 50 ohm BNC termination.

Calibration—465 Service (SN B250000 & up)

b. CHECK—Intensified portion of the sweep begins at the second time marker. (It may be necessary to readjust the INTENSITY control so that the intensified portion of the sweep is visible.)

c. ADJUST—Sweep Start (R1115) so the intensified portion of the sweep begins at the start of the second time marker.

d. Set the DELAY TIME POSITION dial to 9.00.

e. CHECK—Intensified portion of the sweep begins at the tenth time marker.

f. ADJUST—A Sweep Cal (R1145) so the intensified portion of the sweep begins at the start of the tenth time marker.

g. Set:

HORIZ DISPLAY	B DLY'D
DELAY TIME POSITION	1.00

h. CHECK—Displayed pulse starts at the beginning of the sweep.

i. ADJUST—Sweep Start (R1115) so the displayed pulse starts at the beginning of the sweep.

j. Set the DELAY TIME POSITION dial to 9.00.

k. CHECK—Displayed pulse starts at the beginning of the sweep.

l. ADJUST—A Sweep Cal (R1145) so the displayed pulse starts at the beginning of the sweep.

m. INTERACTION—Between Sweep Start and A Sweep Cal adjustments. Repeat both for no visible interaction.

2. Check Delay or Differential Time Linearity

a. Set the DELAY TIME POSITION dial to position the tenth time marker to the beginning of the sweep.

b. Note the reading on the DELAY TIME POSITION dial.

c. Adjust the DELAY TIME POSITION dial so the ninth time marker is at the beginning of the sweep.

d. CHECK—DELAY TIME POSITION dial for a reading 1 division less, within 0.01 division from +15°C to +35°C; 1 division less, within 0.03 division from -15°C to +55°C, than the reading noted in step c.

NOTE

1 division of the DELAY TIME POSITION dial is one complete revolution of the inner knob. 0.01 division is one minor division of the inner knob.

e. Rotate the DELAY TIME POSITION dial to position each successive time marker to the beginning of the sweep.

f. CHECK—DELAY TIME POSITION dial for a reading of 1 division less, within 0.01 division from +15°C to +35°C; 1 division less, within 0.03 division from -15°C to +55°C, than the adjacent time marker.

3. Check/Adjust Horizontal Amplifier Gain

a. Set:

HORIZ DISPLAY	A
A and B TIME/DIV	1 ms
DELAY TIME POSITION	Fully counterclockwise

b. Select 1 millisecond time marks from the time mark generator.

c. CHECK—Display for 1 marker/division $\pm 2\%$ (± 1 minor division at the eleventh time marker).

d. ADJUST—X1 Gain (R1237) for exactly 1 marker/division.

e. Select 0.1 millisecond time marks from the time mark generator.

f. Push the X10 MAG button.

g. CHECK—X10 MAG light is on when the X10 MAG button is pushed in.

h. CHECK—1 marker/division $\pm 3\%$ ($\pm 1 \frac{1}{2}$, minor divisions at the eleventh time marker).

Calibration—465 Service (SN B250000 & up)

i. ADJUST—X10 Gain (R1238) for exactly 1 time marker/division.

4. Check Sweep Linearity

a. CHECK—Linearity over any 2 divisions of the magnified sweep to be within 0.1 division.

b. Release the X10 MAG button.

c. Select 1 millisecond time marks from the time mark generator.

d. CHECK—Linearity over any 2 divisions of the sweep to be within 0.1 division.

5. Check/Adjust Magnifier Registration

a. Push the X10 MAG button in.

b. Select 5 millisecond time markers from the time mark generator.

c. Position the middle time marker to the center vertical graticule line.

d. Release the X10 MAG button.

e. CHECK—Middle time marker is within 0.2 division of the center vertical graticule line.

f. ADJUST—Magnifier Registration (R1225) to position the middle time marker to the center vertical graticule line.

g. Repeat steps c through f until no horizontal shift is observed between X10 MAG in and X10 MAG out.

6. Check/Adjust B Sweep Calibration

a. Set:

DELAY TIME POSITION	Fully counterclockwise
HORIZ DISPLAY	B DLY'D
A TIME/DIV	2 ms
B TIME/DIV	1 ms
X10 MAG	Off (button out)

b. Select 1 millisecond time marks from the time mark generator.

c. CHECK—Display for 1 time marker/division $\pm 2\%$ (1 minor division at the eleventh time marker).

d. ADJUST—B Sweep Cal (R1175) for exactly 1 time marker/division.

7. Check A Sweep Length

a. Set:

A & B TIME/DIV	1 ms
HORIZ DISPLAY	A

b. Select 5 millisecond time marks.

c. Position the third time mark horizontally to the center vertical graticule line.

d. CHECK—Display extends to the right of the center vertical graticule line 1 division (± 0.5 division).

8. Check Variable Time/Division

a. Set the A TIME/DIV switch to 2 ms.

b. Select 5 millisecond time marks from the time mark generator.

c. CHECK—At least 1 time marker per division can be obtained by adjusting the VAR TIME/DIV control.

d. CHECK—UNCAL light comes on when the VAR TIME/DIV control is out of the detent position.

e. Return the VAR TIME/DIV control to the detent position.

9. Check Horizontal Position Range

a. Set the horizontal FINE position to midrange.

b. Turn the horizontal POSITION control fully clockwise.

c. CHECK—Start of sweep is to the right of the center vertical graticule line.

d. Turn the horizontal POSITION control fully counterclockwise.

Calibration—465 Service (SN B250000 & up)

e. CHECK—End of sweep is to the left of the center vertical graticule line.

f. Rotate the horizontal FINE position control.

g. CHECK—FINE position control will position the sweep between one and two divisions.

10. Check/Adjust A 10 Microsecond Timing

a. Set:

DELAY TIME POSITION	1.00
A TIME/DIV	10 μ s
B TIME/DIV	1 μ s

b. Select 10 microsecond time marks from the time mark generator.

c. CHECK—Display for 1 time mark/division $\pm 2\%$ (1 minor division at the eleventh time marker).

d. ADJUST—10 microsecond timing (C1136), with a low capacitance screwdriver, for exactly 1 time marker/division.

e. Set the HORIZ DISPLAY switch to B DLY'D and B SOURCE to STARTS AFTER DELAY.

f. Horizontally position the displayed marker so it is aligned with a vertical graticule line.

g. Set DELAY TIME POSITION to 9.00

h. ADJUST—10 microsecond timing (C1136) with a low capacitance screwdriver, so the display marker is aligned with the same vertical graticule line as in part f.

i. Repeat parts f through h until no error exists between a DELAY TIME POSITION dial setting of 1.00 and 9.00.

11. Check/Adjust A Sweep High Speed Timing

a. Set:

DELAY TIME POSITION	1.50
B SOURCE	STARTS AFTER DELAY
A TIME/DIV	0.5 μ s
B TIME/DIV	0.05 μ s
HORIZ DISPLAY	A

b. Select 0.5 microsecond time marks from the time mark generator.

c. CHECK—Display for 1 time marker/division $\pm 2\%$ (1 minor division at the eleventh time marker).

d. ADJUST—A High Speed Timing (C1137) with the low-capacitance screwdriver, for exactly 1 time marker/division.

e. Switch the HORIZ DISPLAY switch to B DLY'D.

f. Horizontally position the displayed marker so it is aligned with a vertical graticule line.

g. Set DELAY TIME POSITION to 8.50.

h. CHECK—Displayed time marker crosses the center vertical graticule line.

i. ADJUST—A High Speed Timing (C1137) with a low capacitance screwdriver, so the displayed marker is aligned with the same vertical graticule line as in part f.

j. INTERACTION—Between the two positions of the DELAY TIME POSITION dial when adjusting C1137. Compromise the adjustments as necessary to achieve correct timing.

12. Check/Adjust B Sweep High Speed Timing

a. Set:

DELAY TIME POSITION	Fully counterclockwise
HORIZ DISPLAY	B DLY'D
B TRIG SOURCE	NORM
A TIME/DIV	1 μ s
B TIME/DIV	0.5 μ s

b. Adjust the A and B LEVEL controls for a stable display.

c. CHECK—Display for 1 time marker/division $\pm 2\%$ (1 minor division at the eleventh time marker).

d. ADJUST—B High Speed Timing (C1167) with a low capacitance screwdriver, for exactly 1 time marker/division.

13. Check A and B Time/Division Accuracy

- a. CHECK—Using the B TIME/DIV switch and the time mark generator settings given in Table 6-6, check B sweep timing, within 0.2 division, over the first 10 divisions of the display.
- b. Set the HORIZ DISPLAY switch to A.
- c. CHECK—Using the A TIME/DIV switch and the time mark generator settings given in Table 6-6 check A sweep timing within 0.2 division, over the first 10 divisions of the display.

c. CHECK—Display for 1 cycle/2 divisions, within 0.3 division over the full 10 horizontal graticule divisions. Disregard the first and last 10 divisions (5 cycles) of sweep length. See Table 6-7.

d. ADJUST—Magnifier Timing (C1261 and C1281), with the low-capacitance screwdriver for 1 cycle/2 divisions. Disregard the first and last 10 divisions (5 cycles) of sweep length.

15. Check A and B Magnified Timing Accuracy

a. CHECK—Using the A TIME/DIV switch settings and the time mark generator settings given in Table 6-7 check A magnified sweep timing, within 0.3 division over the center 10 divisions of the magnified display. Note the portions of the total magnified sweep length to be excluded from the measurement.

**TABLE 6-6
A AND B TIMING ACCURACY**

A and B TIME/DIV Switch Setting	Time-Mark Generator Output	CRT Display (Markers/Division)
0.05 μ s	50 ns	1
.1 μ s	0.1 μ s	1
.2 μ s	0.1 μ s	2
.5 μ s	0.5 μ s	1
1 μ s	1 μ s	1
2 μ s	1 μ s	2
5 μ s	5 μ s	1
10 μ s	10 μ s	1
20 μ s	10 μ s	2
50 μ s	50 μ s	1
.1 ms	0.1 ms	1
.2 ms	0.1 ms	2
.5 ms	0.5 ms	1
1 ms	1 ms	1
2 ms	1 ms	2
5 ms	5 ms	1
*10 ms	10 ms	1
*20 ms	10 ms	2
*50 ms	50 ms	1
A SWEEP ONLY		
*.1 s	0.1 s	1
*.2 s	0.1 s	1
*.5 s	0.5 s	1

*Switch A TRIG MODE to NORM below 5 ms/div.

14. Check/Adjust High Speed Magnified Timing

- a. Set:
 - X10 MAG On (button pushed in)
 - HORIZONTAL POSITION Midrange
 - A TIME/DIV 0.05 μ s
 - A TRIG MODE Auto
- b. Select the 10 nanosecond output from the time mark generator.

**TABLE 6-7
A AND B MAGNIFIED ACCURACY**

A and B TIME/DIV Switch Setting	Time-Mark Generator Output	CRT Display (Markers/Division)	Portions of total magnified sweep length to exclude from measurement
0.05 μ s	5 ns	1	First and last 10 divisions
.1 μ s	10 ns	1	First and last 5 divisions
.2 μ s	10 ns	2	First and last 2.5 divisions
.5 μ s	50 ns	1	
1 μ s	0.1 μ s	1	
2 μ s	0.1 μ s	2	
5 μ s	0.5 μ s	1	
10 μ s	1 μ s	1	
20 μ s	1 μ s	2	
50 μ s	5 μ s	1	
.1 ms	10 μ s	1	
.2 ms	10 μ s	2	
.5 ms	50 μ s	1	
1 ms	0.1 ms	1	
2 ms	0.1 ms	2	
5 ms	0.5 ms	1	
*10 ms	1 ms	1	
*20 ms	1 ms	2	
*50 ms	5 ms	1	
A SWEEP ONLY			
*.1 s	10 ms	1	
*.2 s	10 ms	2	
*.5 s	50 ms	1	

*Switch TRIG MODE to NORM below 5 ms/div.

Calibration—465 Service (SN B250000 & up)

- b. Set the HORIZ DISPLAY switch to B DLY'D.
- c. CHECK—Using the B TIME/DIV switch and the time mark generator settings given in Table 6-7 check B magnified sweep timing, within 0.3 division over the center 10 divisions of the magnified display. Note the portions of the total magnified sweep length to be excluded from the measurement.
- d. Release the X10 MAG button.

16. Check Delay or Differential Time Accuracy

a. Set:

B TRIG SOURCE	STARTS AFTER DELAY
A TRIG MODE	AUTO
A and B TIME/DIV	According to Table 6-8

b. CHECK—Using the A TIME/DIV switch, B TIME/DIV switch and the time mark generator settings given in Table 6-8 check differential time accuracy is

TABLE 6-8

DIFFERENTIAL TIME ACCURACY

A TIME/DIV Switch Setting	B TIME/DIV Switch Setting	Time-Mark Generator Output	Allowable error for given accuracy
.2 μ s	.05 μ s	.1 μ s	±8 minor dial divisions
.5 μ s	.05 μ s	.5 μ s	
1 μ s	.1 μ s	1 μ s	
2 μ s	.1 μ s	1 μ s	
5 μ s	.5 μ s	5 μ s	
10 μ s	1 μ s	10 μ s	
20 μ s	1 μ s	10 μ s	
50 μ s	5 μ s	50 μ s	
.1 ms	10 μ s	.1 ms	
.2 ms	10 μ s	.1 ms	
.5 ms	50 μ s	.5 ms	
1 ms	.1 ms	1 ms	
2 ms	.1 ms	1 ms	
5 ms	.5 ms	5 ms	
*10 ms	1 ms	10 ms	
*20 ms	1 ms	10 ms	
*50 ms	5 ms	50 ms	
*.1 s	10 ms	.1 s	
*.2 s	10 ms	.1 s	
*.5 s	50 ms	.5 s	

*Set A TRIG MODE to NORM below 5 ms/div.

within the given tolerance. First set the DELAY TIME POSITION dial to 1.00 and rotate the dial slightly until the sweep starts at the top of the second time marker. Note the control setting and then set the dial to 9.00 and rotate it slightly until the sweep starts at the top of the tenth time marker. DELAY TIME POSITION dial setting must be 8.00 divisions higher, ±0.08 divisions.

NOTE

Sweep will start at the top of the third time marker at 1.00 and at the top of the nineteenth time marker at 9.00 for sweep rates which are multiples of 2 (e.g., 2 μ s, 20 μ s, 0.2 ms, etc). If in doubt as to the correct setting of the DELAY TIME POSITION dial, set the HORIZ DISPLAY switch to A INTEN and check which marker is intensified.

17. Check Delay or Differential Time Jitter

a. Set:

DELAY TIME POSITION	1.00
HORIZ DISPLAY	B DLY'D
A TIME/DIV	1 ms
B TIME/DIV	0.2 μ s
TRIG MODE	AUTO

b. Position the time marker near the center of the display area with the DELAY TIME POSITION dial.

c. CHECK—Jitter on the leading edge of the time marker should not exceed 1 division (2.5 divisions if the instrument is being operated on a 50 hertz line voltage). Disregard the slow drift.

d. Turn the DELAY TIME POSITION dial to 9.00 and slightly readjust so the time marker is displayed near the center of the display area.

e. CHECK—Jitter on the leading edge of the time marker should not exceed 1 division (2.5 divisions if the instrument is being operated on a 50 hertz line voltage). Disregard the slow drift.

18. Check Mixed Sweep Accuracy

a. Set:

A TIME/DIV	1 ms
B TIME/DIV	0.5 ms
HORIZ DISPLAY	A
B SOURCE	STARTS AFTER DELAY
DELAY TIME POSITION	Fully clockwise

Calibration—465 Service (SN B250000 & up)

b. Select 1 millisecond time marks from the time mark generator.

c. CHECK—Timing between the second and tenth time markers. Note any timing error for use in step e.

d. Set the HORIZ DISPLAY switch to MIX.

e. CHECK—Timing between second and tenth time markers is within 0.16 division, \pm the A Sweep error noted in step c.

f. Disconnect the test setup.

19. Check/Adjust X Gain

a. Set:

A and B TIME/DIV	X-Y
VERT MODE	CH 2
CH 1 and CH 2	
VOLTS/DIV	5 mV
CH 1 AC-GND-DC	AC
CH 2 AC-GND-DC	GND
HORIZ MODE	A

b. Connect a 20 millivolt standard amplitude signal from the calibration generator to the CH 1 input via a 50 ohm unterminated BNC cable.

c. CHECK—Display for 4 divisions of horizontal deflection $\pm 4\%$ (0.16 division).

d. Switch the CH 1 AC-GND-DC switch to DC.

e. CHECK—Display for 4 divisions of horizontal deflection $\pm 4\%$ (0.16 division). It is normal for this check to be slightly less than that observed in step c.

f. Set the CH 1 AC-GND-DC switch to AC.

g. ADJUST—X Gain (R1215) for exactly 4 divisions of horizontal deflection.

20. Check X-Y Phasing and Bandwidth

a. Connect the output of the leveled sine-wave generator to the Ch 1 and CH 2 inputs via a 50 ohm BNC cable, 50 ohm BNC termination, and a dual input coupler.

b. Adjust the leveled sine-wave generator for an 8 division horizontal display of 50 kilohertz.

c. Set the CH 2 AC-GND-DC switch to AC.

d. Center the display vertically and horizontally with the HORIZ POSITION and CH 2 POSITION controls.

e. CHECK—Display for an opening at the center horizontal graticule line of 0.4 division or less.

f. Set the CH 2 AC-GND-DC switch to GND.

g. Adjust the leveled sine-wave generator for a 10 division horizontal display of 50 kilohertz.

h. Increase the leveled sine-wave generator frequency until the display is reduced to 7 divisions.

i. CHECK—Output frequency of the leveled sine-wave generator is at least 4 megahertz.

j. Disconnect the test setup.

21. Check B Ends A

a. Set:

HORIZ DISPLAY	A INTEN
A TIME/DIV	1 ms
B TIME/DIV	0.1 ms
A TRIG HOLDOFF	B ENDS A (in detent)

b. Adjust the INTENSITY control so the A sweep portion of the display is visible.

c. Rotate the DELAY TIME POSITION dial through its range.

d. CHECK—A sweep ends after the intensified portion at all settings of the DELAY TIME POSITION dial.

22. Check A Trigger Holdoff

a. Set:

HORIZ DISPLAY	A
A TRIG HOLDOFF	Fully counterclockwise
A TRIGGER LEVEL	Fully clockwise

Calibration—465 Service (SN B250000 & up)

b. Connect the A GATE output signal to the test oscilloscope via a 50 ohm BNC cable.

c. Set the test oscilloscope TIME/DIV switch and VAR TIME/DIV so that the bottom portion of the waveform (holdoff time of the A GATE) is exactly 1 division in length.

d. Rotate the A TRIG HOLDOFF control clockwise.

e. CHECK—At least 10 times increase in the holdoff time of the A GATE.

f. Set the A TRIG HOLDOFF control fully counterclockwise.

g. Disconnect test equipment.

GATES, CALIBRATOR AND EXT Z AXIS

Equipment Required

- | | |
|-------------------------------------------|-------------------------------|
| 1. Test Oscilloscope | 4. Shorting Strap |
| 2. 42 Inch, 50 ohm BNC cable (2 required) | 5. Calibration Generator |
| 3. Digital Voltmeter | 6. BNC Tee Connector |
| | 7. 3 Inch slotted Screwdriver |

See **ADJUSTMENT LOCATIONS 1** in the Diagrams section for adjustments and test points (TP).

465 Control Settings (*Indicates Change From Previous Step)

Power Controls

Regulating Range Selector	Medium
Line Voltage Selector	115 V
POWER	ON

CRT Controls

INTENSITY	As desired
FOCUS	Best focused display
SCALE ILLUM	As desired

Vertical Controls (both A and B if applicable)

VOLTS/DIV	5 mV
VAR	Calibrated detent
POSITION	Midrange
VERT MODE	CH 1
INVERT	Off (button out)
20 MHz BW (Pull)	Off (No yellow showing)

Triggering Controls (both A and B if applicable)

LEVEL	Fully clockwise
SLOPE	+
COUPLING	AC
A SOURCE	NORM
B SOURCE	STARTS AFTER DELAY
TRIG MODE	AUTO

Sweep Controls

*HORIZ DISPLAY	*B DLY'D
*DELAY TIME POSITION	*Fully counterclockwise
*A TIME/DIV	*50 μ s
*B TIME/DIV	*50 μ s
VAR TIME/DIV	Calibrated detent
X10 MAG	Off (button out)
POSITION	Midrange
FINE	Midrange
A TRIG HOLDOFF	NORM

1. Check A and B +Gates

a. Connect the B +GATE output (from the back of the 465) to the test oscilloscope via a 50 ohm BNC cable.

b. CHECK—Test oscilloscope display for a positive-going pulse of 5.5 volts in amplitude (within 0.5 volt).

c. Disconnect the cable from the B +GATE output and connect it to the A +GATE output.

d. CHECK—Test oscilloscope display for a positive-going pulse of 5.5 volts in amplitude (within 0.5 volt).

e. Disconnect test equipment.

Calibration—465 Service (SN B250000 & up)

2. Check/Adjust Calibrator DC Level

- a. Connect a shorting strap between TP1594 and TP1590.
- b. Connect the digital voltmeter between the CALIBRATOR current loop and ground.
- c. CHECK—CALIBRATOR dc level is 300 millivolts $\pm 0.3\%$ (299.1 to 300.9 millivolts).
- d. ADJUST—Calibrator Amplitude (R1597) for exactly 300 millivolts.
- e. Remove the shorting strap and the digital voltmeter connections.
- f. Connect a X10 probe from the test oscilloscope to the CALIBRATOR current loop.
- g. CHECK—Test oscilloscope display for a 0.3 volt squarewave with a duration of about 1 millisecond.
- h. Remove the test setup.

3. Check External Z Axis

- a. Set:

HORIZ DISPLAY	A
A TIME/DIV	0.2 ms
A TRIGGER SOURCE	EXT
- b. Set the INTENSITY control for a normal viewing level.
- c. Connect a 5 volt standard amplitude signal from the calibration generator via a 50 ohm BNC cable, BNC T connector to the A EXT trigger input, BNC cable from BNC tee to EXT Z AXIS input.
- d. Adjust A LEVEL for a stable display (TRIG light on).
- e. CHECK—Display for noticeable intensity modulation.
- f. Disconnect the test setup.

REPLACEABLE ELECTRICAL PARTS

PARTS ORDERING INFORMATION

Replacement parts are available from or through your local Tektronix, Inc. Field Office or representative.

Changes to Tektronix instruments are sometimes made to accommodate improved components as they become available, and to give you the benefit of the latest circuit improvements developed in our engineering department. It is therefore important, when ordering parts, to include the following information in your order: Part number, instrument type or number, serial number, and modification number if applicable.

If a part you have ordered has been replaced with a new or improved part, your local Tektronix, Inc. Field Office or representative will contact you concerning any change in part number.

Change information, if any, is located at the rear of this manual.

SPECIAL NOTES AND SYMBOLS

X000 Part first added at this serial number
00X Part removed after this serial number

ITEM NAME

In the Parts List, an Item Name is separated from the description by a colon (:). Because of space limitations, an Item Name may sometimes appear as incomplete. For further Item Name identification, the U.S. Federal Cataloging Handbook H6-1 can be utilized where possible.

ABBREVIATIONS

ACTR	ACTUATOR	PLSTC	PLASTIC
ASSY	ASSEMBLY	QTZ	QUARTZ
CAP	CAPACITOR	RECP	RECEPTACLE
CER	CERAMIC	RES	RESISTOR
CKT	CIRCUIT	RF	RADIO FREQUENCY
COMP	COMPOSITION	SEL	SELECTED
CONN	CONNECTOR	SEMICOND	SEMICONDUCTOR
ELCTLT	ELECTROLYTIC	SENS	SENSITIVE
ELEC	ELECTRICAL	VAR	VARIABLE
INCAND	INCANDESCENT	WW	WIREWOUND
LED	LIGHT EMITTING DIODE	XFMR	TRANSFORMER
NONWIR	NON WIREWOUND	XTAL	CRYSTAL

CROSS INDEX—MFR. CODE NUMBER TO MANUFACTURER

Mfr. Code	Manufacturer	Address	City, State, Zip
00213	NYTRONICS, COMPONENTS GROUP, INC., SUBSIDIARY OF NYTRONICS, INC.	ORANGE STREET	DARLINGTON, SC 29532
00779	AMP, INC.	P O BOX 3608	HARRISBURG, PA 17105
00853	SANGAMO ELECTRIC CO., S. CAROLINA DIV.	P O BOX 128	PICKENS, SC 29671
01121	ALLEN-BRADLEY COMPANY	1201 2ND STREET SOUTH	MILWAUKEE, WI 53204
01281	TRW ELECTRONIC COMPONENTS, SEMICONDUCTOR OPERATIONS	14520 AVIATION BLVD.	LAWDALE, CA 90260
01295	TEXAS INSTRUMENTS, INC., SEMICONDUCTOR GROUP	P O BOX 5012, 13500 N CENTRAL EXPRESSWAY	DALLAS, TX 75222
01963	CHERRY ELECTRICAL PRODUCTS CORPORATION	3600 SUNSET AVENUE	WAUKEGAN, IL 60085
02111	SPECTROL ELECTRONICS CORPORATION	17070 EAST GALE AVENUE	CITY OF INDUSTRY, CA 91745
02735	RCA CORPORATION, SOLID STATE DIVISION	ROUTE 202	SOMERVILLE, NY 08876
03508	GENERAL ELECTRIC COMPANY, SEMI-CONDUCTOR PRODUCTS DEPARTMENT	ELECTRONICS PARK	SYRACUSE, NY 13201
03888	KDI PYROFILM CORPORATION	60 S JEFFERSON ROAD	WHIPPANY, NJ 07981
04222	AVX CERAMICS, DIVISION OF AVX CORP.	P O BOX 867, 19TH AVE. SOUTH	MURTL BEACH, SC 29577
04713	MOTOROLA, INC., SEMICONDUCTOR PROD. DIV.	5005 E MCDOWELL RD, PO BOX 20923	PHOENIX, AZ 85036
05091	TRI-ORDINATE CORPORATION	343 SNYDER AVENUE	BERKELEY HEIGHTS, NJ 07922
05397	UNION CARBIDE CORPORATION, MATERIALS SYSTEMS DIVISION	11901 MADISON AVENUE	CLEVELAND, OH 44101
07263	FAIRCHILD SEMICONDUCTOR, A DIV. OF FAIRCHILD CAMERA AND INSTRUMENT CORP.	464 ELLIS STREET	MOUNTAIN VIEW, CA 94042
07910	TELEDYNE SEMICONDUCTOR	12515 CHADRON AVE.	HAWTHORNE, CA 90250
08806	GENERAL ELECTRIC CO., MINIATURE LAMP PRODUCTS DEPARTMENT	NELA PARK	CLEVELAND, OH 44112
09353	C AND K COMPONENTS, INC.	103 MORSE STREET	WATERTOWN, MA 02172
12697	CLAROSTAT MFG. CO., INC.	LOWER WASHINGTON STREET	DOVER, NH 03820
12969	UNITRODE CORPORATION	580 PLEASANT STREET	WATERTOWN, MA 02172
14193	CAL-R, INC.	1601 OLYMPIC BLVD.	SANTA MONICA, CA 90404
15454	RODAN INDUSTRIES, INC.	2905 BLUE STAR ST.	ANAHEIM, CA 92806
15818	TELEDYNE SEMICONDUCTOR	1300 TERRA BELLA AVE.	MOUNTAIN VIEW, CA 94043
24931	SPECIALTY CONNECTOR CO., INC.	3560 MADISON AVE.	INDIANAPOLIS, IN 46227
25088	SIEMENS CORP.	186 WOOD AVE. S	ISELIN, NJ 08830
27014	NATIONAL SEMICONDUCTOR CORP.	2900 SEMICONDUCTOR DR.	SANTA CLARA, CA 95051
28480	HEWLETT-PACKARD CO., CORPORATE HQ.	1501 PAGE MILL RD.	PALO ALTO, CA 94304
32293	INTERSIL, INC.	10900 N. TANTAU AVE.	CUPERTINO, CA 95014
32997	BOURNS, INC., TRIMPOT PRODUCTS DIV.	1200 COLUMBIA AVE.	RIVERSIDE, CA 92507
34553	AMPEREX ELECTRONIC CORP., COMPONENT DIV.	35 HOFFMAN AVE.	HAPPAUGE, NY 11787
50157	N. L. INDUSTRIES, INC., ELECTRONICS DEPT.	P. O. BOX 787	MUSKEGON, MI 49445
51642	CENTRE ENGINEERING INC.	2820 E COLLEGE AVENUE	STATE COLLEGE, PA 16801
56289	SPRAGUE ELECTRIC CO.		NORTH ADAMS, MA 01247
71400	BUSSMAN MFG., DIVISION OF MCGRAW- EDISON CO.	2536 W. UNIVERSITY ST.	ST. LOUIS, MO 63107
71590	CENTRALAB ELECTRONICS, DIV. OF GLOBE-UNION, INC.	P O BOX 858	FORT DODGE, IA 50501
72982	ERIE TECHNOLOGICAL PRODUCTS, INC.	644 W. 12TH ST.	ERIE, PA 16512
73138	BECKMAN INSTRUMENTS, INC., HELIPOT DIV.	2500 HARBOR BLVD.	FULLERTON, CA 92634
75042	TRW ELECTRONIC COMPONENTS, IRC FIXED RESISTORS, PHILADELPHIA DIVISION	401 N. BROAD ST.	PHILADELPHIA, PA 19108
76493	BELL INDUSTRIES, INC., MILLER, J. W., DIV.	19070 REYES AVE., P O BOX 5825	COMPTON, CA 90224
78488	STACKPOLE CARBON CO.		ST. MARYS, PA 15857
80009	TEKTRONIX, INC.	P O BOX 500	BEAVERTON, OR 97077
80031	ELECTRA-MIDLAND CORP., MEPCO DIV.	22 COLUMBIA ROAD	MORRISTOWN, NJ 07960
80740	BECKMAN INSTRUMENTS, INC.	2500 HARBOR BLVD.	FULLERTON, CA 92634
81483	INTERNATIONAL RECTIFIER CORP.	9220 SUNSET BLVD.	LOS ANGELES, CA 90069
82389	SWITCHCRAFT, INC.	5555 N. ELSTON AVE.	CHICAGO, IL 60630
83003	VARO, INC.	P O BOX 411, 2203 WALNUT STREET	GARLAND, TX 75040
90201	MALLORY CAPACITOR CO., DIV. OF P. R. MALLORY AND CO., INC.	3029 E WASHINGTON STREET P O BOX 372	INDIANAPOLIS, IN 46206
91418	RADIO MATERIALS COMPANY, DIV. OF P.R. MALLORY AND COMPANY, INC.	4242 W BRYN MAWR	CHICAGO, IL 60646
91637	DALE ELECTRONICS, INC.	P. O. BOX 609	COLUMBUS, NE 68601
93410	ESSEX INTERNATIONAL, INC., CONTROLS DIV. LEXINGTON PLANT	P. O. BOX 1007	MANSFIELD, OH 44903

Replaceable Electrical Parts—465 Service (SN B25000-up)

Ckt No.	Tektronix Part No.	Serial/Model No. Eff	Dscont	Name & Description	Mfr Code	Mfr Part Number
A1	670-2434-01			CKT BOARD ASSY:CH 1 ATTEN	80009	670-2434-01
A2	670-2434-01			CKT BOARD ASSY:CH 2 ATTEN	80009	670-2434-01
A3	670-2237-00			CKT BOARD ASSY:VERT PREAMP	80009	670-2237-00
A3 ¹						
A4	670-2236-00	B250000	B251724	CKT BOARD ASSY:VERT MODE	80009	670-2236-00
A4	670-2236-01	B251725		CKT BOARD ASSY:VERT MODE	80009	670-2236-01
A5	670-2238-00			CKT BOARD ASSY:VERT OUTPUT (IC)	80009	670-2238-00
A5	670-3023-02			CKT BOARD ASSY:VERT OUTPUT (DESCRETE)	80009	670-3023-02
A6	670-2245-00			CKT BOARD ASSY:FAN MOTOR	80009	670-2245-00
A7	670-3467-00			CKT BOARD ASSY:TIMING	80009	670-3467-00
A7 ¹						
A8	670-2234-02	B250000	B251094	CKT BOARD ASSY:TRIG GEN AND SWP LOGIC	80009	670-2234-02
A8 ¹						
A8	670-2234-04	B251095		CKT BOARD ASSY:TRIG GEN AND SWP LOGIC	80009	670-2234-04
A9	670-2233-05			CKT BOARD ASSY:INTERFACE	80009	670-2233-05
A10	670-2279-00			CKT BOARD ASSY:GRATICULE ILLUM	80009	670-2279-00
B1690	147-0035-00			MOTOR,DC:BRUSHLESS,10-15VDC,145MA	25088	1AD3001-0A
C1	281-0064-00			CAP.,VAR,PLSTC:0.25-1.5PF,600V	72982	530-002
C2	281-0661-00			CAP.,FXD,CER DI:0.8PF,+/-0.1PF,500V	72982	301-000COK0808B
C3	285-0816-01			CAP.,FXD,PLSTC:0.019UF,10%,600V	80009	285-0816-01
C6	283-0000-00			CAP.,FXD,CER DI:0.001UF,+100-0%,500V	72982	831-516E102P
C7	283-0000-00			CAP.,FXD,CER DI:0.001UF,+100-0%,500V	72982	831-516E102P
C10	307-1014-02	B250000	B289109	ATTENUATOR,FXD:100X	80009	307-1014-02
C11						
C10	307-1014-01	B289110		ATTENUATOR,FXD:100X	80009	307-1014-01
C11						
C12	307-1013-00			ATTENUATOR,FXD:10X	80009	307-1013-00
C13						
C16	283-0001-00			CAP.,FXD,CER DI:0.005UF,+100-0%,500V	72982	831-559E502P
C18	281-0626-00			CAP.,FXD,CER DI:3.3PF,1%,500V	72982	301-000C0J0339B
C21	283-0004-00			CAP.,FXD,CER DI:0.02UF,+80-20%,150V	72982	855-558-Z5V0203Z
C22	283-0087-00			CAP.,FXD,CER DI:300PF,10%,1000V	56289	403637
C23	290-0517-00			CAP.,FXD,ELCTLT:6.8UF,20%,35V	56289	196D685X0035KA1
C25	283-0004-00			CAP.,FXD,CER DI:0.02UF,+80-20%,150V	72982	855-558-Z5V0203Z
C27	281-0207-00			CAP.,VAR,PLSTC:2-18PF,100V	80031	HT10EA/218
C33	281-0207-00			CAP.,VAR,PLSTC:2-18PF,100V	80031	HT10EA/218
C34	283-0139-00			CAP.,FXD,CER DI:150PF,20%,50V	51642	100-050X5F151M
C36	283-0004-00			CAP.,FXD,CER DI:0.02UF,+80-20%,150V	72982	855-558-Z5V0203Z
C37	281-0536-00			CAP.,FXD,CER DI:1000PF,10%,500V	72982	301055X5P102K
C38	281-0536-00			CAP.,FXD,CER DI:1000PF,10%,500V	72982	301055X5P102K
C39	283-0004-00			CAP.,FXD,CER DI:0.02UF,+80-20%,150V	72982	855-558-Z5V0203Z
C42	283-0004-00			CAP.,FXD,CER DI:0.02UF,+80-20%,150V	72982	855-558-Z5V0203Z
C46	281-0626-00			CAP.,FXD,CER DI:3.3PF,1%,500V	72982	301-000C0J0339B
C47	281-0182-00			CAP.,VAR,PLSTC:1.8-10PF,500V	34553	2222-809-05002
C48	281-0182-00			CAP.,VAR,PLSTC:1.8-10PF,500V	34553	2222-809-05002
C49	281-0621-00			CAP.,FXD,CER DI:12PF,1%,500V	72982	301-000C0G0120F
C51	281-0064-00			CAP.,VAR,PLSTC:0.25-1.5PF,600V	72982	530-002
C52	281-0661-00			CAP.,FXD,CER DI:0.8PF,+/-0.1PF,500V	72982	301-000COK0808B
C53	285-0816-01			CAP.,FXD,PLSTC:0.019UF,10%,600V	80009	285-0816-01
C56	283-0000-00			CAP.,FXD,CER DI:0.001UF,+100-0%,500V	72982	831-516E102P
C57	283-0000-00			CAP.,FXD,CER DI:0.001UF,+100-0%,500V	72982	831-516E102P
C60	307-1014-02	B250000	B289109	ATTENUATOR,FXD:100X	80009	307-1014-02
C61						

¹See DM manual for alternate version.

Replaceable Electrical Parts—465 Service (SN B250000-up)

Ckt No.	Tektronix Part No.	Serial/Model No. Eff Dscont	Name & Description	Mfr Code	Mfr Part Number
C60)	307-1014-01	B289110	ATTENUATOR,FXD:100X	80009	307-1014-01
C61)	307-1013-00		ATTENUATOR,FXD:10X	80009	307-1013-00
C62)					
C63)					
C66	283-0001-00		CAP.,FXD,CER DI:0.005UF,+100-0%,500V	72982	831-559E502P
C68	281-0626-00		CAP.,FXD,CER DI:3.3PF,1%,500V	72982	301-000C0J0339B
C71	283-0004-00		CAP.,FXD,CER DI:0.02UF,+80-20%,150V	72982	855-558-Z5V0203Z
C72	283-0087-00		CAP.,FXD,CER DI:300PF,10%,1000V	56289	403637
C73	290-0517-00		CAP.,FXD,ELCTLT:6.8UF,20%,35V	56289	196D685X0035KA1
C75	283-0004-00		CAP.,FXD,CER DI:0.02UF,+80-20%,150V	72982	855-558-Z5V0203Z
C77	281-0184-00		CAP.,VAR,PLSTC:2-18PF,500VDC	34553	2222-809-05003
C82	290-0517-00		CAP.,FXD,ELCTLT:6.8UF,20%,35V	56289	196D685X0035KA1
C83	281-0207-00		CAP.,VAR,PLSTC:2-18PF,100V	80031	HT10EA/218
C84	283-0139-00		CAP.,FXD,CER DI:150PF,20%,50V	51642	100-050X5F151M
C87	281-0536-00		CAP.,FXD,CER DI:1000PF,10%,500V	72982	301055X5P102K
C88	281-0536-00		CAP.,FXD,CER DI:1000PF,10%,500V	72982	301055X5P102K
C92	283-0004-00		CAP.,FXD,CER DI:0.02UF,+80-20%,150V	72982	855-558-Z5V0203Z
C96	281-0626-00		CAP.,FXD,CER DI:3.3PF,1%,500V	72982	301-000C0J0339B
C97	281-0182-00		CAP.,VAR,PLSTC:1.8-10PF,500V	34553	2222-809-05002
C98	281-0182-00		CAP.,VAR,PLSTC:1.8-10PF,500V	34553	2222-809-05002
C99	281-0621-00		CAP.,FXD,CER DI:12PF,1%,500V	72982	301-000C0G0120F
C101	281-0628-00		CAP.,FXD,CER DI:15PF,5%,500V	72982	301-000C0G0150J
C102	290-0517-00		CAP.,FXD,ELCTLT:6.8UF,20%,35V	56289	196D685X0035KA1
C105	281-0207-00		CAP.,VAR,PLSTC:2-18PF,100V	80031	HT10EA/218
C107	281-0536-00		CAP.,FXD,CER DI:1000PF,10%,500V	72982	301055X5P102K
C109	281-0536-00		CAP.,FXD,CER DI:1000PF,10%,500V	72982	301055X5P102K
C122	281-0207-00		CAP.,VAR,PLSTC:2-18PF,100V	80031	HT10EA/218
C124	283-0004-00		CAP.,FXD,CER DI:0.02UF,+80-20%,150V	72982	855-558-Z5V0203Z
C125	290-0517-00		CAP.,FXD,ELCTLT:6.8UF,20%,35V	56289	196D685X0035KA1
C135	281-0525-00		CAP.,FXD,CER DI:470PF,+/-94PF,500V	04222	7001-1364
C137	281-0525-00		CAP.,FXD,CER DI:470PF,+/-94PF,500V	04222	7001-1364
C142	283-0003-00		CAP.,FXD,CER DI:0.01UF,+80-20%,150V	72982	855-558Z5U-103Z
C144	281-0625-00		CAP.,FXD,CER DI:35PF,5%,500V	72982	308-000C0G0350J
C149	281-0207-00		CAP.,VAR,PLSTC:2-18PF,100V	80031	HT10EA/218
C151	281-0525-00		CAP.,FXD,CER DI:470PF,+/-94PF,500V	04222	7001-1364
C161	290-0517-00		CAP.,FXD,ELCTLT:6.8UF,20%,35V	56289	196D685X0035KA1
C162	281-0512-00		CAP.,FXD,CER DI:27PF,+/-2.7PF,500V	72982	308-000C0G0270K
C164	290-0517-00		CAP.,FXD,ELCTLT:6.8UF,20%,35V	56289	196D685X0035KA1
C165	283-0004-00		CAP.,FXD,CER DI:0.02UF,+80-20%,150V	72982	855-558-Z5V0203Z
C201	281-0628-00		CAP.,FXD,CER DI:15PF,5%,500V	72982	301-000C0G0150J
C202	283-0004-00		CAP.,FXD,CER DI:0.02UF,+80-20%,150V	72982	855-558-Z5V0203Z
C205	281-0207-00		CAP.,VAR,PLSTC:2-18PF,100V	80031	HT10EA/218
C207	281-0536-00		CAP.,FXD,CER DI:1000PF,10%,500V	72982	301055X5P102K
C209	281-0536-00		CAP.,FXD,CER DI:1000PF,10%,500V	72982	301055X5P102K
C225	283-0004-00		CAP.,FXD,CER DI:0.02UF,+80-20%,150V	72982	855-558-Z5V0203Z
C229	290-0517-00		CAP.,FXD,ELCTLT:6.8UF,20%,35V	56289	196D685X0035KA1
C235	281-0525-00		CAP.,FXD,CER DI:470PF,+/-94PF,500V	04222	7001-1364
C237	281-0525-00		CAP.,FXD,CER DI:470PF,+/-94PF,500V	04222	7001-1364
C242	283-0003-00		CAP.,FXD,CER DI:0.01UF,+80-20%,150V	72982	855-558Z5U-103Z
C245	281-0628-00		CAP.,FXD,CER DI:15PF,5%,500V	72982	301-000C0G0150J
C249	281-0207-00		CAP.,VAR,PLSTC:2-18PF,100V	80031	HT10EA/218
C251	281-0525-00		CAP.,FXD,CER DI:470PF,+/-94PF,500V	04222	7001-1364

Replaceable Electrical Parts—465 Service (SN B25000-up)

Ckt No.	Tektronix Part No.	Serial/Model No. Eff	Dscont	Name & Description	Mfr Code	Mfr Part Number
C253	283-0000-00			CAP., FXD, CER DI:0.001UF, +100-0%, 500V	72982	831-516E102P
C261	290-0517-00			CAP., FXD, ELCTLT:6.8UF, 20%, 35V	56289	196D685X0035KA1
C262	281-0519-00			CAP., FXD, CER DI:47PF, +/-4.7PF, 500V	72982	308-000COG0470K
C302	290-0517-00			CAP., FXD, ELCTLT:6.8UF, 20%, 35V	56289	196D685X0035KA1
C321	283-0004-00			CAP., FXD, CER DI:0.02UF, +80-20%, 150V	72982	855-558-Z5V0203Z
C334	283-0004-00			CAP., FXD, CER DI:0.02UF, +80-20%, 150V	72982	855-558-Z5V0203Z
C338	281-0579-00			CAP., FXD, CER DI:21PF, 5%, 500V	72982	301-050COG0210J
C339	283-0644-00			CAP., FXD, MICA D:150PF, 1%, 500V	00853	D151E151F0
C346	290-0517-00			CAP., FXD, ELCTLT:6.8UF, 20%, 35V	56289	196D685X0035KA1
C347	281-0504-00			CAP., FXD, CER DI:10PF, +/-1PF, 500V	72982	301-055COG0100F
C349	281-0578-00			CAP., FXD, CER DI:18PF, 5%, 500V	72982	301-050COG0180J
C351	281-0549-00			CAP., FXD, CER DI:68PF, 10%, 500V	72982	301-000U2J0680K
C352	290-0517-00			CAP., FXD, ELCTLT:6.8UF, 20%, 35V	56289	196D685X0035KA1
C354	283-0004-00			CAP., FXD, CER DI:0.02UF, +80-20%, 150V	72982	855-558-Z5V0203Z
C356	281-0549-00			CAP., FXD, CER DI:68PF, 10%, 500V	72982	301-000U2J0680K
C358	290-0517-00			CAP., FXD, ELCTLT:6.8UF, 20%, 35V	56289	196D685X0035KA1
C361	290-0517-00			CAP., FXD, ELCTLT:6.8UF, 20%, 35V	56289	196D685X0035KA1
C362	290-0517-00			CAP., FXD, ELCTLT:6.8UF, 20%, 35V	56289	196D685X0035KA1
C363	290-0517-00			CAP., FXD, ELCTLT:6.8UF, 20%, 35V	56289	196D685X0035KA1
C364	281-0504-00			CAP., FXD, CER DI:10PF, +/-1PF, 500V	72982	301-055COG0100F
C368	283-0058-00	B250000	B279999	CAP., FXD, CER DI:0.027UF, 10%, 100V	72982	8131N147W5R273K
C368	283-0370-00	B280000		CAP., FXD, CER DI:0.027UF, 5%, 100V	72982	8131N153X7R0273J
C374	281-0504-00			CAP., FXD, CER DI:10PF, +/-1PF, 500V	72982	301-055COG0100F
C381	283-0000-00			CAP., FXD, CER DI:0.001UF, +100-0%, 500V	72982	831-516E102P
C391	283-0000-00			CAP., FXD, CER DI:0.001UF, +100-0%, 500V	72982	831-516E102P
C403	281-0089-00			CAP., VAR, CER DI:2-8PF, 350V	72982	538-006-A2-8
C407	283-0081-00			CAP., FXD, CER DI:0.1UF, +80-20%, 25V	56289	36C600
C417	283-0081-00			CAP., FXD, CER DI:0.1UF, +80-20%, 25V	56289	36C600
C423	283-0180-00			CAP., FXD, CER DI:5600PF, 20%, 200V	72982	8121N204 E 562M
C424	283-0198-00			CAP., FXD, CER DI:0.22UF, 20%, 50V	72982	8131N075 E224M
C433	283-0119-00			CAP., FXD, CER DI:2200PF, 5%, 200V	72982	855-535B222J
C434	283-0341-00			CAP., FXD, CER DI:0.047UF, 10%, 100V	72982	8131N127X7R0473K
C441	283-0636-00			CAP., FXD, MICA D:36PF, 1.4%, 100V	00853	D155E360G0
C442	281-0089-00			CAP., VAR, CER DI:2-8PF, 350V	72982	538-006-A2-8
C443	281-0096-00			CAP., VAR, AIR DI:5.5-18PF, 350V	72982	538-006-A5.5-18
C444	281-0602-00			CAP., FXD, CER DI:68PF, 5%, 500V	72982	308-000P2G0680J
C445	283-0660-00			CAP., FXD, MICA D:510PF, 2%, 500V	00853	D155F511G0
C451	283-0144-00			CAP., FXD, CER DI:33PF, 1%, 500V	72982	801-547P2G330G
C453	283-0000-00			CAP., FXD, CER DI:0.001UF, +100-0%, 500V	72982	831-516E102P
C457	283-0010-00			CAP., FXD, CER DI:0.05UF, +100-20%, 50V	56289	273C20
C458	283-0081-00			CAP., FXD, CER DI:0.1UF, +80-20%, 25V	56289	36C600
C459	283-0023-00			CAP., FXD, CER DI:0.1UF, +80-20%, 12V	91418	MX104Z1201R0
C464	283-0178-00			CAP., FXD, CER DI:0.1UF, +80-20%, 100V	72982	8131N145 E 104Z
C471	283-0178-00			CAP., FXD, CER DI:0.1UF, +80-20%, 100V	72982	8131N145 E 104Z
C502	281-0579-00			CAP., FXD, CER DI:21PF, 5%, 500V	72982	301-050COG0210J
C503	281-0651-00			CAP., FXD, CER DI:47PF, 5%, 200V	72982	374-001T2H0470J
C511	281-0523-00			CAP., FXD, CER DI:100PF, +/-20PF, 500V	72982	301-000U2M0101M
C512	283-0004-00			CAP., FXD, CER DI:0.02UF, +80-20%, 150V	72982	855-558-Z5V0203Z
C515	281-0511-00			CAP., FXD, CER DI:22PF, +/-2.2PF, 500V	72982	301-000COG0220K
C522	283-0003-00			CAP., FXD, CER DI:0.01UF, +80-20%, 150V	72982	855-558Z5U-103Z
C525	283-0003-00			CAP., FXD, CER DI:0.01UF, +80-20%, 150V	72982	855-558Z5U-103Z
C528	281-0511-00			CAP., FXD, CER DI:22PF, +/-2.2PF, 500V	72982	301-000COG0220K
C531	283-0003-00			CAP., FXD, CER DI:0.01UF, +80-20%, 150V	72982	855-558Z5U-103Z

Replaceable Electrical Parts—465 Service (SN B250000-up)

Ckt No.	Tektronix Part No.	Serial/Model No. Eff	Dscont	Name & Description	Mfr Code	Mfr Part Number
C549	283-0003-00			CAP.,FXD,CER DI:0.01UF,+80-20%,150V	72982	855-558Z5U-103Z
C601	283-0167-00			CAP.,FXD,CER DI:0.1UF,10%,100V	72982	81314147 C 104K
C602	281-0611-00			CAP.,FXD,CER DI:2.7PF,+/-0.25PF,200V	72982	374-001C0J0279C
C603	281-0670-00			CAP.,FXD,CER DI:1.8PF,+/-0.1PF,500V	72982	374-005C0K0189B
C604	281-0523-00			CAP.,FXD,CER DI:100PF,+/-20PF,500V	72982	301-000U2M0101M
C606	281-0628-00			CAP.,FXD,CER DI:15PF,5%,500V	72982	301-000C0G0150J
C607	281-0515-00			CAP.,FXD,CER DI:27PF,+/-1.35PF,500V	72982	302-005C0G0270J
C611	281-0523-00			CAP.,FXD,CER DI:100PF,+/-20PF,500V	72982	301-000U2M0101M
C612	283-0004-00			CAP.,FXD,CER DI:0.02UF,+80-20%,150V	72982	855-558-Z5V0203Z
C615	281-0511-00			CAP.,FXD,CER DI:22PF,+/-2.2PF,500V	72982	301-000C0G0220K
C622	283-0003-00			CAP.,FXD,CER DI:0.01UF,+80-20%,150V	72982	855-558Z5U-103Z
C625	283-0003-00			CAP.,FXD,CER DI:0.01UF,+80-20%,150V	72982	855-558Z5U-103Z
C628	281-0511-00			CAP.,FXD,CER DI:22PF,+/-2.2PF,500V	72982	301-000C0G0220K
C631	283-0003-00			CAP.,FXD,CER DI:0.01UF,+80-20%,150V	72982	855-558Z5U-103Z
C649	283-0003-00			CAP.,FXD,CER DI:0.01UF,+80-20%,150V	72982	855-558Z5U-103Z
C655	290-0527-00			CAP.,FXD,ELCTLT:15UF,20%,20V	90201	TDC156M020FL
C676	281-0540-00			CAP.,FXD,CER DI:51PF,5%,500V	72982	301-000U2J0510J
C678 ¹	XXX-XXXX-XX			CAP.,FXD,CER DI:33PF,(NOM VALUE),SEL		
C690	283-0024-00			CAP.,FXD,CER DI:0.1UF,+80-20%,30V	72982	8131N039Z5U-104Z
C805	290-0527-00			CAP.,FXD,ELCTLT:15UF,20%,20V	90201	TDC156M020FL
C808	281-0577-00			CAP.,FXD,CER DI:14PF,5%,500V	72982	301-050C0G0140J
C824	281-0511-00			CAP.,FXD,CER DI:22PF,+/-2.2PF,500V	72982	301-000C0G0220K
C826	281-0523-00			CAP.,FXD,CER DI:100PF,+/-20PF,500V	72982	301-000U2M0101M
C829	290-0529-00			CAP.,FXD,ELCTLT:47UF,20%,20V	05397	T368C476M020AZ
C834	290-0527-00			CAP.,FXD,ELCTLT:15UF,20%,20V	90201	TDC156M020FL
C835	290-0527-00			CAP.,FXD,ELCTLT:15UF,20%,20V	90201	TDC156M020FL
C836	290-0527-00			CAP.,FXD,ELCTLT:15UF,20%,20V	90201	TDC156M020FL
C837	281-0524-00			CAP.,FXD,CER DI:150PF,+/-30PF,500V	04222	7001-1381
C839	290-0536-00			CAP.,FXD,ELCTLT:10UF,20%,25V	90201	TDC106M025FL
C853	283-0024-00			CAP.,FXD,CER DI:0.1UF,+80-20%,30V	72982	8131N039Z5U-104Z
C855	290-0527-00			CAP.,FXD,ELCTLT:15UF,20%,20V	90201	TDC156M020FL
C858	281-0577-00	B250000	B251094	CAP.,FXD,CER DI:14PF,5%,500V	72982	301-050C0G0140J
C858	281-0564-00	B151095		CAP.,FXD,CER DI:24PF,5%,500V	72982	301-000C0G0240J
C863	281-0523-00			CAP.,FXD,CER DI:100PF,+/-20PF,500V	72982	301-000U2M0101M
C874	290-0527-00			CAP.,FXD,ELCTLT:15UF,20%,20V	90201	TDC156M020FL
C877	281-0508-00			CAP.,FXD,CER DI:12PF,+/-0.6PF,500V	72982	301-000C0G0120J
C879	290-0522-00			CAP.,FXD,ELCTLT:1UF,20%,50V	56289	196D105X0050HA1
C891	290-0527-00			CAP.,FXD,ELCTLT:15UF,20%,20V	90201	TDC156M020FL
C893	290-0527-00			CAP.,FXD,ELCTLT:15UF,20%,20V	90201	TDC156M020FL
C896	290-0527-00			CAP.,FXD,ELCTLT:15UF,20%,20V	90201	TDC156M020FL
C897	290-0527-00			CAP.,FXD,ELCTLT:15UF,20%,20V	90201	TDC156M020FL
C1000	283-0004-00			CAP.,FXD,CER DI:0.02UF,+80-20%,150V	72982	855-558-Z5V0203Z
C1002	283-0178-00			CAP.,FXD,CER DI:0.1UF,+80-20%,100V	72982	8131N145 E 104Z
C1003	281-0637-00			CAP.,FXD,CER DI:91PF,5%,500V	72982	301000Z5D910J
C1017	281-0511-00			CAP.,FXD,CER DI:22PF,+/-2.2PF,500V	72982	301-000C0G0220K
C1021	283-0004-00	B250000	B296898	CAP.,FXD,CER DI:0.02UF,+80-20%,150V	72982	855-558-Z5V0203Z
C1021	283-0028-00	B296899		CAP.,FXD,CER DI:0.0022UF,20%,50V	56289	19C606
C1024	290-0527-00			CAP.,FXD,ELCTLT:15UF,20%,20V	90201	TDC156M020FL
C1026	281-0523-00			CAP.,FXD,CER DI:100PF,+/-20PF,500V	72982	301-000U2M0101M
C1031	283-0004-00			CAP.,FXD,CER DI:0.02UF,+80-20%,150V	7298	855-558-Z5V0203Z
C1036	281-0579-00			CAP.,FXD,CER DI:21PF,5%,500V	72982	301-050C0G0210J
C1038	290-0527-00			CAP.,FXD,ELCTLT:15UF,20%,20V	90201	TDC156M020FL
C1039	283-0023-00			CAP.,FXD,CER DI:0.1UF,+80-20%,12V	91418	MX104Z1201R0

¹Selected and added if necessary.

Replaceable Electrical Parts—465 Service (SN B250000-up)

Ckt No.	Tektronix Part No.	Serial/Model No. Eff	Dscont	Name & Description	Mfr Code	Mfr Part Number
C1044 ¹	290-0523-00			CAP.,FXD,ELCTLT:2.2UF,20%,20V	56289	196D225X0020HA1
C1062	283-0178-00			CAP.,FXD,CER DI:0.1UF,+80-20%,100V	72982	8131N145 E 104Z
C1063	281-0637-00			CAP.,FXD,CER DI:91PF,5%,500V	72982	301000Z5D910J
C1065	281-0629-00			CAP.,FXD,CER DI:33PF,5%,600V	72982	308-000C0G0330J
C1077	281-0511-00			CAP.,FXD,CER DI:22PF,+/-2.2PF,500V	72982	301-000C0G0220K
C1081	283-0004-00			CAP.,FXD,CER DI:0.02UF,+80-20%,150V	72982	855-558-Z5V0203Z
C1084	290-0527-00			CAP.,FXD,ELCTLT:15UF,20%,20V	90201	TDC156M020FL
C1086	281-0523-00			CAP.,FXD,CER DI:100PF,+/-20PF,500V	72982	301-000U2M0101M
C1091	283-0004-00			CAP.,FXD,CER DI:0.02UF,+80-20%,150V	72982	855-558-Z5V0203Z
C1096	281-0578-00			CAP.,FXD,CER DI:18PF,5%,500V	72982	301-050C0G0180J
C1099	283-0023-00			CAP.,FXD,CER DI:0.1UF,+80-20%,12V	91418	MX104Z1201R0
C1113	290-0519-00			CAP.,FXD,ELCTLT:100UF,20%,20V	56289	196D107X0020MA3
C1117	283-0080-00			CAP.,FXD,CER DI:0.022UF,+80-20%,25V	56289	19C611
C1130	281-0629-00			CAP.,FXD,CER DI:33PF,5%,600V	72982	308-000C0G0330J
C1131 ²				CAP.,SET MTCHD:9.95UF		
C1133	295-0175-00			CAP.,SET,MTCHD:0.1UF,9.95UF,985UF,0.2%	80009	295-0175-00
C1135				CAP.,SET MTCHD:985PF		
C1136	281-0096-00			CAP.,VAR,AIR DI:5.5-18PF,350V	72982	538-006-A5.5-18
C1137	281-0089-00			CAP.,VAR,CER DI:2-8PF,350V	72982	538-006-A2-8
C1138	283-0331-00			CAP.,FXD,CER DI:43PF,2%,100V	72982	805-505A430G
C1151	283-0268-00			CAP.,FXD,CER DI:0.015UF,10%,50V	72982	8131N075W5R153K
C1152	290-0245-00			CAP.,FXD,ELCTLT:1.5UF,10%,10V	56289	150D155X9010A2
C1153	283-0645-00			CAP.,FXD,MICA D:790PF,1%,100V	00853	D151E791F0
C1161 ²				CAP.,SET,MTCHD:1UF		
C1163	295-0157-00			CAP.,SET,MTCHD:0.1UF,1UF,998PF	80009	295-0157-00
C1165				CAP.,SET,MTCHD:998PF		
C1167	281-0089-00			CAP.,VAR,CER DI:2-8PF,350V	72982	538-006-A2-8
C1168	283-0331-00			CAP.,FXD,CER DI:43PF,2%,100V	72982	805-505A430G
C1201	283-0023-00			CAP.,FXD,CER DI:0.1UF,+80-20%,12V	91418	MX104Z1201R0
C1208	283-0004-00			CAP.,FXD,CER DI:0.02UF,+80-20%,150V	72982	855-558-Z5V0203Z
C1209	283-0004-00			CAP.,FXD,CER DI:0.02UF,+80-20%,150V	72982	855-558-Z5V0203Z
C1220	290-0650-00	B250000	B291513	CAP.,FXD,ELCTLT:1000UF,20%,10V	56289	109D108X0010T2
C1220	290-0759-00	B291514	B294619	CAP.,FXD,ELCTLT:290UF,+75-10%,15V	90201	TTX291U015C1A3
C1220	290-0807-00	B294620		CAP.,FXD,ELCTLT:1000UF,+100-10%,10VDC	90201	TT102N010E1C3P
C1235	283-0178-00			CAP.,FXD,CER DI:0.1UF,+80-20%,100V	72982	8131N145 E 104Z
C1249	283-0004-00			CAP.,FXD,CER DI:0.02UF,+80-20%,150V	72982	855-558-Z5V0203Z
C1256	283-0024-00			CAP.,FXD,CER DI:0.1UF,+80-20%,30V	72982	8131N039Z5U-104Z
C1261	281-0064-00			CAP.,VAR,PLSTC:0.25-1.5PF,600V	72982	530-002
C1262	283-0092-00	B250000	B291513	CAP.,FXD,CER DI:0.03UF,+80-20%,200V	72982	845-534E303Z
C1262	283-0328-00	B291514		CAP.,FXD,CER DI:0.03UF,+80-20%,200V	72982	8131N225651303Z
C1263	283-0003-00			CAP.,FXD,CER DI:0.01UF,+80-20%,150V	72982	855-558Z5U-103Z
C1269	283-0003-00			CAP.,FXD,CER DI:0.01UF,+80-20%,150V	72982	855-558Z5U-103Z
C1281	281-0064-00			CAP.,VAR,PLSTC:0.25-1.5PF,600V	72982	530-002
C1282	283-0092-00	B250000	B291513	CAP.,FXD,CER DI:0.03UF,+80-20%,200V	72982	845-534E303Z
C1282	283-0328-00	B291514		CAP.,FXD,CER DI:0.03UF,+80-20%,200V	72982	8131N225651303Z
C1283	283-0003-00			CAP.,FXD,CER DI:0.01UF,+80-20%,150V	72982	855-558Z5U-103Z
C1288	283-0003-00			CAP.,FXD,CER DI:0.01UF,+80-20%,150V	72982	855-558Z5U-103Z
C1307	281-0611-00			CAP.,FXD,CER DI:2.7PF,+/-0.25PF,200V	72982	374-001C0J0279C
C1327	281-0611-00			CAP.,FXD,CER DI:2.7PF,+/-0.25PF,200V	72982	374-001C0J0279C
C1339	283-0081-00			CAP.,FXD,CER DI:0.1UF,+80-20%,25V	56289	36C600
C1348	283-0023-00			CAP.,FXD,CER DI:0.1UF,+80-20%,12V	91418	MX104Z1201R0
C1349	283-0023-00			CAP.,FXD,CER DI:0.1UF,+80-20%,12V	91418	MX104Z1201R0
C1403	283-0198-00			CAP.,FXD,CER DI:0.22UF,20%,50V	72982	8131N075 E224M

¹Not used with DM44.

²Individual timing capacitors in this assembly must be ordered by the 9-digit part number, letter suffix and tolerance printed on the timing capacitor to be replaced. The letter suffix and the tolerance should be the same for all of the timing capacitors in the assembly.

EXAMPLE: 285-XXXX-XX F-

Replaceable Electrical Parts—465 Service (SN B250000-up)

Ckt No.	Tektronix Part No.	Serial/Model No. Eff	Dscont	Name & Description	Mfr Code	Mfr Part Number
C1404	290-0149-00			CAP.,FXD,ELCTLT:5UF,+75-10%,150V	56289	30D505G150DD4
C1412	290-0536-00			CAP.,FXD,ELCTLT:10UF,20%,25V	90201	TDC106M025FL
C1416	283-0203-00			CAP.,FXD,CER DI:0.47UF,20%,50V	72982	8131N075 E474M
C1418	290-0718-00	XB289565		CAP.,FXD,ELCTLT:22UF,20%,35V	56289	196D226X0035PE3
C1419	290-0560-00	B250000	B289564	CAP.,FXD,ELCTLT:47UF,20%,25V	56289	196D476X0025MA3
C1419	290-0718-00	B289565		CAP.,FXD,ELCTLT:22UF,20%,35V	56289	196D226X0035PE3
C1420	281-0622-00			CAP.,FXD,CER DI:47PF,1%,500V	72982	308-000C0G0470F
C1421	283-0071-00			CAP.,FXD,CER DI:0.0068UF,+80-30%,5000V	56289	45C10A1
C1422	283-0071-00			CAP.,FXD,CER DI:0.0068UF,+80-30%,5000V	56289	45C10A1
C1423	283-0071-00			CAP.,FXD,CER DI:0.0068UF,+80-30%,5000V	56289	45C10A1
C1424	285-1040-00			CAP.,FXD,PLSTC:0.0012UF,10%,4000V	56289	430P522
C1427	283-0002-00			CAP.,FXD,CER DI:0.01UF,+80-20%,500V	72982	811-546E103Z
C1430	285-1040-00			CAP.,FXD,PLSTC:0.0012UF,10%,4000V	56289	430P522
C1442	283-0003-00			CAP.,FXD,CER DI:0.01UF,+80-20%,150V	72982	855-558Z5U-103Z
C1445	283-0003-00			CAP.,FXD,CER DI:0.01UF,+80-20%,150V	72982	855-558Z5U-103Z
C1447	283-0003-00			CAP.,FXD,CER DI:0.01UF,+80-20%,150V	72982	855-558Z5U-103Z
C1449	283-0003-00			CAP.,FXD,CER DI:0.01UF,+80-20%,150V	72982	855-558Z5U-103Z
C1452	281-0580-00			CAP.,FXD,CER DI:470PF,10%,500V	04222	7001-1374
C1471	281-0064-00			CAP.,VAR,PLSTC:0.25-1.5PF,600V	72982	530-002
C1474	283-0111-00			CAP.,FXD,CER DI:0.1UF,20%,50V	72982	8121-N088Z5U104M
C1475	283-0000-00			CAP.,FXD,CER DI:0.001UF,+100-0%,500V	72982	831-516E102P
C1476	283-0057-00			CAP.,FXD,CER DI:0.1UF,+80-20%,200V	56289	274C10
C1477	283-0057-00			CAP.,FXD,CER DI:0.1UF,+80-20%,200V	56289	274C10
C1481	290-0164-00			CAP.,FXD,ELCTLT:1UF,+50-10%,150V	56289	30D105F150BA2
C1484	283-0178-00			CAP.,FXD,CER DI:0.1UF,+80-20%,100V	72982	8131N145 E 104Z
C1487	283-0101-00			CAP.,FXD,CER DI:4700PF,+80-20%,6000V	56289	45C11A
C1488	285-1040-00			CAP.,FXD,PLSTC:0.0012UF,10%,4000V	56289	430P522
C1510	283-0167-00			CAP.,FXD,CER DI:0.1UF,10%,100V	72982	81314147 C 104K
C1511	281-0580-00			CAP.,FXD,CER DI:470PF,10%,500V	04222	7001-1374
C1512	290-0670-00			CAP.,FXD,ELCTLT:550UF,+75-10%,100V	56289	68D10512
C1513	290-0638-00			CAP.,FXD,ELCTLT:1200UF,+75-10%,100V	56289	68D10529
C1522	283-0004-00			CAP.,FXD,CER DI:0.02UF,+80-20%,150V	72982	855-558-Z5V0203Z
C1525	283-0178-00			CAP.,FXD,CER DI:0.1UF,+80-20%,100V	72982	8131N145 E 104Z
C1534	290-0305-00			CAP.,FXD,ELCTLT:3UF,20%,150V	56289	109D305X0150C2
C1537	281-0550-00			CAP.,FXD,CER DI:120PF,10%,500V	04222	7001-1373
C1542	290-0584-00			CAP.,FXD,ELCTLT:5500UF,+100-10%,30V	90201	20-36094
C1549	290-0529-00			CAP.,FXD,ELCTLT:47UF,20%,20V	05397	T368C476M020AZ
C1552	290-0571-00			CAP.,FXD,ELCTLT:5000UF,+100-0%,25V	90201	PPF20-36043
C1559	290-0535-00			CAP.,FXD,ELCTLT:33UF,20%,10V	56289	196D336X0010KA1
C1562	290-0583-00			CAP.,FXD,ELCTLT:3000UF,+100-10%,35V	56289	68D10490
C1569	290-0535-00			CAP.,FXD,ELCTLT:33UF,20%,10V	56289	196D336X0010KA1
C1587	290-0523-00			CAP.,FXD,ELCTLT:2.2UF,20%,20V	56289	196D225X0020HA1
C1592	285-0686-00			CAP.,FXD,PLSTC:0.068UF,10%,100V	56289	410P68391
C1593	281-0551-00			CAP.,FXD,CER DI:390PF,10%,500V	04222	7001-1363
C1596	290-0532-00			CAP.,FXD,ELCTLT:150UF,20%,6V	90201	TDC157M006WLC
C1597	281-0513-00			CAP.,FXD,CER DI:27PF,+/-5.4PF,500V	72982	301-000P2G0270M
C1698	290-0536-00			CAP.,FXD,ELCTLT:10UF,20%,25V	90201	TDC106M025FL
C4402	283-0032-00			CAP.,FXD,CER DI:470PF,5%,500V	72982	831-500Z5D471J
C4412	283-0032-00			CAP.,FXD,CER DI:470PF,5%,500V	72982	831-500Z5D471J
C4422	281-0139-00			CAP.,VAR,CER DI:2.5-9PF,100V	72982	518-002A2.5-9
C4425	281-0638-00			CAP.,FXD,CER DI:240PF,5%,500V	72982	301000Z5D241J
C4427	281-0524-00			CAP.,FXD,CER DI:150PF,+/-30PF,500V	04222	7001-1381
C4430	283-0000-00			CAP.,FXD,CER DI:0.001UF,+100-0%,500V	72982	831-516E102P

Replaceable Electrical Parts—465 Service (SN B25000-up)

Ckt No.	Tektronix Part No.	Serial/Model No. Eff	Dscont	Name & Description	Mfr Code	Mfr Part Number
C4432	283-0065-00			CAP., FXD, CER DI:0.001UF, 5%, 100V	72982	805-505B102J
C4437	281-0629-00			CAP., FXD, CER DI:33PF, 5%, 600V	72982	308-000C0G0330J
C4438	281-0123-00			CAP., VAR, CER DI:5-25PF, 100V	72982	518-000A5-25
C4439	281-0617-00			CAP., FXD, CER DI:15PF, 10%, 200V	72982	374-001C0G0150K
C4442	283-0065-00			CAP., FXD, CER DI:0.001UF, 5%, 100V	72982	805-505B102J
C4444 ¹	281-0651-00			CAP., FXD, CER DI:47PF, 5%, 200V	72982	374-001T2H0470J
C4464 ¹						
C4474 ¹						
C4481	283-0077-00			CAP., FXD, CER DI:330PF, 5%, 500V	56289	40C94A3
C4482	283-0000-00			CAP., FXD, CER DI:0.001UF, +100-0%, 500V	72982	831-516E102P
C4485	283-0003-00			CAP., FXD, CER DI:0.01UF, +80-20%, 150V	72982	855-558Z5U-103Z
C4491	283-0077-00			CAP., FXD, CER DI:330PF, 5%, 500V	56289	40C94A3
C4492	283-0000-00			CAP., FXD, CER DI:0.001UF, +100-0%, 500V	72982	831-516E102P
C4498	290-0523-00			CAP., FXD, ELCTLT:2.2UF, 20%, 20V	56289	196D225X0020HA1
C4499	290-0523-00			CAP., FXD, ELCTLT:2.2UF, 20%, 20V	56289	196D225X0020HA1
CR18	152-0323-00			SEMICOND DEVICE:SILICON, 35V, 100MA	80009	152-0323-00
CR31	152-0153-00			SEMICOND DEVICE:SILICON, 15V, 50MA	80009	152-0153-00
CR32	152-0153-00			SEMICOND DEVICE:SILICON, 15V, 50MA	80009	152-0153-00
CR34	152-0271-00			SEMICOND DEVICE:SILICON, 10PF	80009	152-0271-00
CR39	152-0460-00			SEMICOND DEVICE:100V, 1MA	04713	1N5299
CR68	152-0323-00			SEMICOND DEVICE:SILICON, 35V, 100MA	80009	152-0323-00
CR81	152-0153-00			SEMICOND DEVICE:SILICON, 15V, 50MA	80009	152-0153-00
CR82	152-0153-00			SEMICOND DEVICE:SILICON, 15V, 50MA	80009	152-0153-00
CR84	152-0271-00			SEMICOND DEVICE:SILICON, 10PF	80009	152-0271-00
CR152	152-0141-02			SEMICOND DEVICE:SILICON, 30V, 150MA	07910	1N4152
CR164	152-0141-02			SEMICOND DEVICE:SILICON, 30V, 150MA	07910	1N4152
CR165	152-0141-02			SEMICOND DEVICE:SILICON, 30V, 150MA	07910	1N4152
CR166	152-0141-02			SEMICOND DEVICE:SILICON, 30V, 150MA	07910	1N4152
CR167	152-0141-02			SEMICOND DEVICE:SILICON, 30V, 150MA	07910	1N4152
CR252	152-0141-02			SEMICOND DEVICE:SILICON, 30V, 150MA	07910	1N4152
CR304	152-0153-00			SEMICOND DEVICE:SILICON, 15V, 50MA	80009	152-0153-00
CR305	152-0153-00			SEMICOND DEVICE:SILICON, 15V, 50MA	80009	152-0153-00
CR307	152-0153-00			SEMICOND DEVICE:SILICON, 15V, 50MA	80009	152-0153-00
CR308	152-0153-00			SEMICOND DEVICE:SILICON, 15V, 50MA	80009	152-0153-00
CR314	152-0153-00			SEMICOND DEVICE:SILICON, 15V, 50MA	80009	152-0153-00
CR315	152-0153-00			SEMICOND DEVICE:SILICON, 15V, 50MA	80009	152-0153-00
CR317	152-0153-00			SEMICOND DEVICE:SILICON, 15V, 50MA	80009	152-0153-00
CR318	152-0153-00			SEMICOND DEVICE:SILICON, 15V, 50MA	80009	152-0153-00
CR342	152-0141-02			SEMICOND DEVICE:SILICON, 30V, 150MA	07910	1N4152
CR362	152-0141-02			SEMICOND DEVICE:SILICON, 30V, 150MA	07910	1N4152
CR368	152-0141-02			SEMICOND DEVICE:SILICON, 30V, 150MA	07910	1N4152
CR372	152-0141-02			SEMICOND DEVICE:SILICON, 30V, 150MA	07910	1N4152
CR378	152-0141-02			SEMICOND DEVICE:SILICON, 30V, 150MA	07910	1N4152
CR421	152-0269-00			SEMICOND DEVICE:SILICON, VAR VCAP., 4V, 33PF	80009	152-0269-00
CR422	152-0269-00			SEMICOND DEVICE:SILICON, VAR VCAP., 4V, 33PF	80009	152-0269-00
CR517	152-0246-00			SEMICOND DEVICE:SILICON, 400PIV, 200MA	07910	CD12676
CR550	152-0125-00	B250000	B256799	SEMICOND DEVICE:TUNNEL, 15PF, 4.7MA	80009	152-0125-00
CR550	152-0125-01	B256800		SEMICOND DVC, DI:TUNNEL, 4.7MA, 18PF GE ONLY	80009	152-0125-01
CR552	152-0125-00	B250000	B256799	SEMICOND DEVICE:TUNNEL, 15PF, 4.7MA	80009	152-0125-00
CR552	152-0125-01	B256800		SEMICOND DVC, DI:TUNNEL, 4.7MA, 18PF GE ONLY	80009	152-0125-01
CR553	152-0141-02			SEMICOND DEVICE:SILICON, 30V, 150MA	07910	1N4152
CR554	152-0141-02			SEMICOND DEVICE:SILICON, 30V, 150MA	07910	1N4152
CR617	152-0246-00			SEMICOND DEVICE:SILICON, 400PIV, 200MA	07910	CD12676

¹Part of Circuit Board.

Replaceable Electrical Parts—465 Service (SN B250000-up)

Ckt No.	Tektronix Part No.	Serial/Model No. Eff	Dscont	Name & Description	Mfr Code	Mfr Part Number
CR650	152-0125-00	B250000	B256799	SEMICON D DEVICE:TUNNEL,15PF,4.7MA	80009	152-0125-00
CR650	152-0125-01	B256800		SEMICON DVC,DI:TUNNEL,4.7MA,18PF GE ONLY	80009	152-0125-01
CR652	152-0125-00	B250000	B256799	SEMICON D DEVICE:TUNNEL,15PF,4.7MA	80009	152-0125-00
CR652	152-0125-01	B256800		SEMICON DVC,DI:TUNNEL,4.7MA,18PF GE ONLY	80009	152-0125-01
CR801	152-0322-00			SEMICON D DEVICE:SILICON,15V,HOT CARRIER	28480	5082-2672
CR809	152-0141-02			SEMICON D DEVICE:SILICON,30V,150MA	07910	1N4152
CR818	152-0141-02			SEMICON D DEVICE:SILICON,30V,150MA	07910	1N4152
CR822	152-0141-02			SEMICON D DEVICE:SILICON,30V,150MA	07910	1N4152
CR825	152-0141-02			SEMICON D DEVICE:SILICON,30V,150MA	07910	1N4152
CR826	152-0141-02			SEMICON D DEVICE:SILICON,30V,150MA	07910	1N4152
CR831	152-0141-02			SEMICON D DEVICE:SILICON,30V,150MA	07910	1N4152
CR832	152-0141-02			SEMICON D DEVICE:SILICON,30V,150MA	07910	1N4152
CR838	152-0141-02			SEMICON D DEVICE:SILICON,30V,150MA	07910	1N4152
CR851	152-0322-00			SEMICON D DEVICE:SILICON,15V,HOT CARRIER	28480	5082-2672
CR859	152-0141-02			SEMICON D DEVICE:SILICON,30V,150MA	07910	1N4152
CR862	152-0141-02			SEMICON D DEVICE:SILICON,30V,150MA	07910	1N4152
CR863	152-0141-02			SEMICON D DEVICE:SILICON,30V,150MA	07910	1N4152
CR877	152-0141-02			SEMICON D DEVICE:SILICON,30V,150MA	07910	1N4152
CR1001	152-0141-02			SEMICON D DEVICE:SILICON,30V,150MA	07910	1N4152
CR1004	152-0141-02			SEMICON D DEVICE:SILICON,30V,150MA	07910	1N4152
CR1011	152-0141-02			SEMICON D DEVICE:SILICON,30V,150MA	07910	1N4152
CR1024	152-0141-02			SEMICON D DEVICE:SILICON,30V,150MA	07910	1N4152
CR1035	152-0141-02			SEMICON D DEVICE:SILICON,30V,150MA	07910	1N4152
CR1042	152-0141-02			SEMICON D DEVICE:SILICON,30V,150MA	07910	1N4152
CR1043	152-0141-02			SEMICON D DEVICE:SILICON,30V,150MA	07910	1N4152
CR1061	152-0141-02			SEMICON D DEVICE:SILICON,30V,150MA	07910	1N4152
CR1064	152-0141-02			SEMICON D DEVICE:SILICON,30V,150MA	07910	1N4152
CR1071	152-0141-02			SEMICON D DEVICE:SILICON,30V,150MA	07910	1N4152
CR1095	152-0141-02			SEMICON D DEVICE:SILICON,30V,150MA	07910	1N4152
CR1101	152-0141-02			SEMICON D DEVICE:SILICON,30V,150MA	07910	1N4152
CR1102	152-0141-02			SEMICON D DEVICE:SILICON,30V,150MA	07910	1N4152
CR1153	152-0141-02	XB296392		SEMICON D DEVICE:SILICON,30V,150MA	07910	1N4152
CR1155	152-0333-00			SEMICON D DEVICE:SILICON,55V,200MA	80009	152-0333-00
CR1201	152-0141-02			SEMICON D DEVICE:SILICON,30V,150MA	07910	1N4152
CR1202	152-0141-02			SEMICON D DEVICE:SILICON,30V,150MA	07910	1N4152
CR1218	152-0141-02			SEMICON D DEVICE:SILICON,30V,150MA	07910	1N4152
CR1248	152-0141-02			SEMICON D DEVICE:SILICON,30V,150MA	07910	1N4152
CR1251	152-0153-00			SEMICON D DEVICE:SILICON,15V,50MA	80009	152-0153-00
CR1252	152-0153-00			SEMICON D DEVICE:SILICON,15V,50MA	80009	152-0153-00
CR1253	152-0322-00			SEMICON D DEVICE:SILICON,15V,HOT CARRIER	28480	5082-2672
CR1255	152-0141-02			SEMICON D DEVICE:SILICON,30V,150MA	07910	1N4152
CR1273	152-0322-00			SEMICON D DEVICE:SILICON,15V,HOT CARRIER	28480	5082-2672
CR1275	152-0141-02			SEMICON D DEVICE:SILICON,30V,150MA	07910	1N4152
CR1286	152-0141-02			SEMICON D DEVICE:SILICON,30V,150MA	07910	1N4152
CR1304	152-0141-02			SEMICON D DEVICE:SILICON,30V,150MA	07910	1N4152
CR1306	152-0141-02			SEMICON D DEVICE:SILICON,30V,150MA	07910	1N4152
CR1309	152-0141-02			SEMICON D DEVICE:SILICON,30V,150MA	07910	1N4152
CR1315	152-0141-02			SEMICON D DEVICE:SILICON,30V,150MA	07910	1N4152
CR1316	152-0141-02			SEMICON D DEVICE:SILICON,30V,150MA	07910	1N4152
CR1325	152-0141-02			SEMICON D DEVICE:SILICON,30V,150MA	07910	1N4152
CR1326	152-0141-02			SEMICON D DEVICE:SILICON,30V,150MA	07910	1N4152
CR1334	152-0141-02			SEMICON D DEVICE:SILICON,30V,150MA	07910	1N4152
CR1335	152-0141-02			SEMICON D DEVICE:SILICON,30V,150MA	07910	1N4152

Replaceable Electrical Parts—465 Service (SN B250000-up)

Ckt No.	Tektronix Part No.	Serial/Model No. Eff	Dscont	Name & Description	Mfr Code	Mfr Part Number
CR1336	152-0141-02			SEMICON D DEVICE: SILICON, 30V, 150MA	07910	1N4152
CR1342	152-0141-02			SEMICON D DEVICE: SILICON, 30V, 150MA	07910	1N4152
CR1344	152-0141-02			SEMICON D DEVICE: SILICON, 30V, 150MA	07910	1N4152
CR1345	152-0141-02			SEMICON D DEVICE: SILICON, 30V, 150MA	07910	1N4152
CR1347	152-0141-02			SEMICON D DEVICE: SILICON, 30V, 150MA	07910	1N4152
CR1404	152-0333-00			SEMICON D DEVICE: SILICON, 55V, 200MA	80009	152-0333-00
CR1408	152-0141-02			SEMICON D DEVICE: SILICON, 30V, 150MA	07910	1N4152
CR1412	152-0141-02			SEMICON D DEVICE: SILICON, 30V, 150MA	07910	1N4152
CR1413	152-0141-02			SEMICON D DEVICE: SILICON, 30V, 150MA	07910	1N4152
CR1414	152-0141-02			SEMICON D DEVICE: SILICON, 30V, 150MA	07910	1N4152
CR1416	152-0333-00			SEMICON D DEVICE: SILICON, 55V, 200MA	80009	152-0333-00
CR1421	152-0409-00			SEMICON D DEVICE: SILICON, 12, 000V, 5MA	83003	VG12X
CR1427	152-0107-00			SEMICON D DEVICE: SILICON, 400V, 400MA	80009	152-0107-00
CR1461	152-0141-02			SEMICON D DEVICE: SILICON, 30V, 150MA	07910	1N4152
CR1462	152-0141-02			SEMICON D DEVICE: SILICON, 30V, 150MA	07910	1N4152
CR1463	152-0141-02			SEMICON D DEVICE: SILICON, 30V, 150MA	07910	1N4152
CR1464	152-0153-00			SEMICON D DEVICE: SILICON, 15V, 50MA	80009	152-0153-00
CR1465	152-0141-02			SEMICON D DEVICE: SILICON, 30V, 150MA	07910	1N4152
CR1468	152-0141-02			SEMICON D DEVICE: SILICON, 30V, 150MA	07910	1N4152
CR1472	152-0061-00			SEMICON D DEVICE: SILICON, 175V, 100MA	80009	152-0061-00
CR1476	152-0107-00			SEMICON D DEVICE: SILICON, 400V, 400MA	80009	152-0107-00
CR1482	152-0061-00			SEMICON D DEVICE: SILICON, 175V, 100MA	80009	152-0061-00
CR1483	152-0061-00			SEMICON D DEVICE: SILICON, 175V, 100MA	80009	152-0061-00
CR1487	152-0242-00			SEMICON D DEVICE: SILICON, 225V, 200MA	12969	NDP341
CR1488	152-0242-00			SEMICON D DEVICE: SILICON, 225V, 200MA	12969	NDP341
CR1511	152-0488-00			SEMICON D DEVICE: SILICON, 200V, 1500MA	80009	152-0488-00
CR1514	152-0107-00			SEMICON D DEVICE: SILICON, 400V, 400MA	80009	152-0107-00
CR1516	152-0107-00			SEMICON D DEVICE: SILICON, 400V, 400MA	80009	152-0107-00
CR1524	152-0141-02			SEMICON D DEVICE: SILICON, 30V, 150MA	07910	1N4152
CR1532	152-0061-00			SEMICON D DEVICE: SILICON, 175V, 100MA	80009	152-0061-00
CR1533	152-0141-02			SEMICON D DEVICE: SILICON, 30V, 150MA	07910	1N4152
CR1534	152-0066-00			SEMICON D DEVICE: SILICON, 400V, 750MA	80009	152-0066-00
CR1535	152-0066-00			SEMICON D DEVICE: SILICON, 400V, 750MA	80009	152-0066-00
CR1536	152-0141-02			SEMICON D DEVICE: SILICON, 30V, 150MA	07910	1N4152
CR1541	152-0556-00			SEMICON D DEVICE: BRIDGE, 50V, 2.5A	04713	SDA10271K
CR1549	152-0066-00			SEMICON D DEVICE: SILICON, 400V, 750MA	80009	152-0066-00
CR1551	152-0488-00			SEMICON D DEVICE: SILICON, 200V, 1500MA	80009	152-0488-00
CR1556	152-0141-02			SEMICON D DEVICE: SILICON, 30V, 150MA	07910	1N4152
CR1559	152-0066-00			SEMICON D DEVICE: SILICON, 400V, 750MA	80009	152-0066-00
CR1561	152-0488-00			SEMICON D DEVICE: SILICON, 200V, 1500MA	80009	152-0488-00
CR1564	152-0141-02			SEMICON D DEVICE: SILICON, 30V, 150MA	07910	1N4152
CR1569	152-0066-00			SEMICON D DEVICE: SILICON, 400V, 750MA	80009	152-0066-00
CR1596	152-0141-02			SEMICON D DEVICE: SILICON, 30V, 150MA	07910	1N4152
CR1691	152-0141-02			SEMICON D DEVICE: SILICON, 30V, 150MA	07910	1N4152
CR1692	152-0141-02			SEMICON D DEVICE: SILICON, 30V, 150MA	07910	1N4152
CR1694	152-0141-02			SEMICON D DEVICE: SILICON, 30V, 150MA	07910	1N4152
CR1696	152-0141-02			SEMICON D DEVICE: SILICON, 30V, 150MA	07910	1N4152
CR1699	152-0141-02			SEMICON D DEVICE: SILICON, 30V, 150MA	07910	1N4152
CR4434	152-0422-00			SEMICON D DEVICE: SILICON, 4V, 7PF	01281	PG1084
CR4451	152-0141-02			SEMICON D DEVICE: SILICON, 30V, 150MA	07910	1N4152
CR4452	152-0141-02			SEMICON D DEVICE: SILICON, 30V, 150MA	07910	1N4152
DL339	119-0387-00			DELAY LINE, ELEC:	80009	119-0387-00

Replaceable Electrical Parts—465 Service (SN B250000-up)

Ckt No.	Tektronix Part No.	Serial/Model No. Eff	Dscont	Name & Description	Mfr Code	Mfr Part Number
DS382	150-0130-00			LAMP, INCAND: 5V, 60MA	08806	2200DX
DS386	150-0130-00			LAMP, INCAND: 5V, 60MA	08806	2200DX
DS388	150-0035-00			LAMP, GLOW: 90V, 0.3MA	08806	A1D-T
DS389	150-0035-00			LAMP, GLOW: 90V, 0.3MA	08806	A1D-T
DS392	150-0130-00			LAMP, INCAND: 5V, 60MA	08806	2200DX
DS396	150-0130-00			LAMP, INCAND: 5V, 60MA	08806	2200DX
DS834	150-0130-00			LAMP, INCAND: 5V, 60MA	08806	2200DX
DS836	150-0130-00			LAMP, INCAND: 5V, 60MA	08806	2200DX
DS1140	150-0035-00			LAMP, GLOW: 90V, 0.3MA	08806	A1D-T
DS1239	150-0035-00			LAMP, GLOW: 90V, 0.3MA	08806	A1D-T
DS1425	150-0002-00			LAMP, GLOW: 0.5 MA 60/125V	08806	NE2T-A1AT
DS1426	150-0002-00			LAMP, GLOW: 0.5 MA 60/125V	08806	NE2T-A1AT
DS1570	150-0129-00			LAMP, INCAND: 6.3V, 200MA	08806	2112D
DS1571	150-0129-00			LAMP, INCAND: 6.3V, 200MA	08806	2112D
DS1588	150-0130-00			LAMP, INCAND: 5V, 60MA	08806	2200DX
F1419	159-0016-00			FUSE, CARTRIDGE: 3AG, 1.5A, 250V, FAST-BLOW	71400	AGC 1 1/2
F1501 ¹	159-0016-00			FUSE, CARTRIDGE: 3AG, 1.5A, 250V, FAST-BLOW	71400	AGC 1 1/2
F1501 ²	159-0042-00			FUSE, CARTRIDGE: 3AG, 0.75A, 250V, FAST-BLOW	71400	AGC 3/4
J1	136-0499-14			CONNECTOR, RCPT, :14 CONTACT	00779	4-380949-4
J2	136-0499-10			CONNECTOR, RCPT, :10 CONTACT	00779	4-380949-0
J3	136-0499-04			CONNECTOR, RCPT, :4 CONTACT	00779	3-380949-4
J4	131-0679-01	B250000	B251094	CONNECTOR, RCPT, :BNC W/HARDWARE	24931	28JR168-1
J4	131-0679-02	B251095		CONNECTOR, RCPT, :BNC W/HARDWARE	24931	28JR270-1
J5	136-0499-10			CONNECTOR, RCPT, :10 CONTACT	00779	4-380949-0
J6	136-0499-14			CONNECTOR, RCPT, :14 CONTACT	00779	4-380949-4
J54	131-0679-01	B250000	B251094	CONNECTOR, RCPT, :BNC W/HARDWARE	24931	28JR168-1
J54	131-0679-02	B251095		CONNECTOR, RCPT, :BNC W/HARDWARE	24931	28JR270-1
J162	131-1003-00			CONNECTOR BODY, :CKT CD MT, 3 PRONG	80009	131-1003-00
J164	131-1003-00			CONNECTOR BODY, :CKT CD MT, 3 PRONG	80009	131-1003-00
J165	131-0955-00			CONNECTOR, RCPT, :BNC, FEMALE, W/HARDWARE	05091	31-279
J168	131-1003-00			CONNECTOR BODY, :CKT CD MT, 3 PRONG	80009	131-1003-00
J262	131-1003-00			CONNECTOR BODY, :CKT CD MT, 3 PRONG	80009	131-1003-00
J338	131-1003-00			CONNECTOR BODY, :CKT CD MT, 3 PRONG	80009	131-1003-00
J339	131-1003-00			CONNECTOR BODY, :CKT CD MT, 3 PRONG	80009	131-1003-00
J349	131-1003-00			CONNECTOR BODY, :CKT CD MT, 3 PRONG	80009	131-1003-00
J351	131-1003-00			CONNECTOR BODY, :CKT CD MT, 3 PRONG	80009	131-1003-00
J359	131-1003-00			CONNECTOR BODY, :CKT CD MT, 3 PRONG	80009	131-1003-00
J500	131-0955-00			CONNECTOR, RCPT, :BNC, FEMALE, W/HARDWARE	05091	31-279
J571	131-1003-00			CONNECTOR BODY, :CKT CD MT, 3 PRONG	80009	131-1003-00
J573	131-1003-00			CONNECTOR BODY, :CKT CD MT, 3 PRONG	80009	131-1003-00
J575	131-1003-00			CONNECTOR BODY, :CKT CD MT, 3 PRONG	80009	131-1003-00
J600	131-0955-00			CONNECTOR, RCPT, :BNC, FEMALE, W/HARDWARE	05091	31-279
J678	131-1003-00			CONNECTOR BODY, :CKT CD MT, 3 PRONG	80009	131-1003-00
J688	131-1003-00			CONNECTOR BODY, :CKT CD MT, 3 PRONG	80009	131-1003-00
J1317	131-1003-00			CONNECTOR BODY, :CKT CD MT, 3 PRONG	80009	131-1003-00
J1318	131-0955-00			CONNECTOR, RCPT, :BNC, FEMALE, W/HARDWARE	05091	31-279
J1319	131-1003-00			CONNECTOR BODY, :CKT CD MT, 3 PRONG	80009	131-1003-00
J1337	131-1003-00			CONNECTOR BODY, :CKT CD MT, 3 PRONG	80009	131-1003-00
J1338	131-0955-00			CONNECTOR, RCPT, :BNC, FEMALE, W/HARDWARE	05091	31-279
J1450	131-0955-00			CONNECTOR, RCPT, :BNC, FEMALE, W/HARDWARE	05091	31-279
L122	108-0181-01			COIL, RF: 0.2UH	80009	108-0181-01
L149	108-0181-01			COIL, RF: 0.2UH	80009	108-0181-01

¹For 115V operation

²For 230V operation

Replaceable Electrical Parts—465 Service (SN B250000-up)

Ckt No.	Tektronix Part No.	Serial/Model No. Eff	Dscont	Name & Description	Mfr Code	Mfr Part Number
L249	108-0181-01			COIL,RF:0.2UH	80009	108-0181-01
L338	108-0182-00			COIL,RF:0.3UH	80009	108-0182-00
L339	108-0182-00			COIL,RF:0.3UH	80009	108-0182-00
L440	108-0370-00			COIL,RF:0.14UH	80009	108-0370-00
L442	108-0370-00			COIL,RF:0.14UH	80009	108-0370-00
L461	108-0740-00			TRANSFORMER,RF:225NH	80009	108-0740-00
L471	108-0740-00			TRANSFORMER,RF:225NH	80009	108-0740-00
L507	108-0655-00			COIL,RF:75NH	80009	108-0655-00
L546	108-0370-00			COIL,RF:0.14UH	80009	108-0370-00
L547	108-0370-00			COIL,RF:0.14UH	80009	108-0370-00
L646	108-0370-00			COIL,RF:0.14UH	80009	108-0370-00
L647	108-0370-00			COIL,RF:0.14UH	80009	108-0370-00
L874	108-0538-00			COIL,RF:2.7UH	76493	70F276A1
L891	108-0538-00			COIL,RF:2.7UH	76493	70F276A1
L893	108-0538-00			COIL,RF:2.7UH	76493	70F276A1
L897	108-0538-00			COIL,RF:2.7UH	76493	70F276A1
L1006	108-0328-00			COIL,RF:0.3UH	80009	108-0328-00
L1419	108-0422-00			COIL,RF:80UH	80009	108-0422-00
L1440	108-0713-00			COIL,TUBE DEFLE:TRACE ROTATION	80009	108-0713-00
L1446	108-0714-00			COIL,TUBE DEFLE:Y AXIS ALIGNMENT	80009	108-0714-00
L1596	108-0245-00			COIL,RF:3.9UH	80009	108-0245-00
L4402 ¹	276-0507-00			SHIELDING BEAD,:0.6UH	78488	57-0180-7D 500B
L4464	108-0570-00			COIL,RF:75NH	80009	108-0570-00
L4474	108-0570-00			COIL,RF:75NH	80009	108-0570-00
L4498	108-0440-00			COIL,RF:8UH,TOROIDAL INDUCTOR	80009	108-0440-00
L4499	108-0440-00			COIL,RF:8UH,TOROIDAL INDUCTOR	80009	108-0440-00
LR461	108-0284-00			COIL,RF:0.1UH	80009	108-0284-00
LR471	108-0284-00			COIL,RF:0.1UH	80009	108-0284-00
LR4483	108-0328-00			COIL,RF:0.3UH	80009	108-0328-00
LR4493	108-0328-00			COIL,RF:0.3UH	80009	108-0328-00
Q20A,B	151-1032-00			TRANSISTOR:SILICON,FET,DUAL	80009	151-1032-00
Q32	151-0259-00			TRANSISTOR:SILICON,NPN	80009	151-0259-00
Q36	151-0259-00			TRANSISTOR:SILICON,NPN	80009	151-0259-00
Q42	151-0221-00			TRANSISTOR:SILICON,PNP	80009	151-0221-00
Q44	151-0221-00			TRANSISTOR:SILICON,PNP	80009	151-0221-00
Q70A,B	151-1032-00			TRANSISTOR:SILICON,FET,DUAL	80009	151-1032-00
Q82	151-0259-00			TRANSISTOR:SILICON,NPN	80009	151-0259-00
Q86	151-0259-00			TRANSISTOR:SILICON,NPN	80009	151-0259-00
Q92	151-0221-00			TRANSISTOR:SILICON,PNP	80009	151-0221-00
Q94	151-0221-00			TRANSISTOR:SILICON,PNP	80009	151-0221-00
Q102	151-0427-00			TRANSISTOR:SILICON,NPN	80009	151-0427-00
Q104	151-0427-00			TRANSISTOR:SILICON,NPN	80009	151-0427-00
Q122	151-0198-00			TRANSISTOR:SILICON,NPN,SEL FROM MPS918	80009	151-0198-00
Q124	151-0198-00			TRANSISTOR:SILICON,NPN,SEL FROM MPS918	80009	151-0198-00
Q132 ²	153-0609-00			SEMICOND DVC SE:SILICON,PNP	80009	153-0609-00
Q134 ¹						
Q142	151-0271-00			TRANSISTOR:SILICON,PNP	80009	151-0271-00
Q148	151-0271-00			TRANSISTOR:SILICON,PNP	80009	151-0271-00
Q152	151-0221-00			TRANSISTOR:SILICON,PNP	80009	151-0221-00
Q162	151-0221-00			TRANSISTOR:SILICON,PNP	80009	151-0221-00
Q164	151-0221-00			TRANSISTOR:SILICON,PNP	80009	151-0221-00
Q168	151-0190-00			TRANSISTOR:SILICON,NPN	80009	151-0190-00

¹Added if necessary.

²Q132 and Q134 furnished as a matched pair.

Replaceable Electrical Parts—465 Service (SN B250000-up)

Ckt No.	Tektronix Part No.	Serial/Model No. Eff	Dscont	Name & Description	Mfr Code	Mfr Part Number
Q202	151-0427-00			TRANSISTOR:SILICON,NPN	80009	151-0427-00
Q204	151-0427-00			TRANSISTOR:SILICON,NPN	80009	151-0427-00
Q222)	153-0547-00			SEMICON DVC SE:SILICON,NPN,MATCHED	80009	153-0547-00
Q224)						
Q226)	153-0547-00			SEMICON DVC SE:SILICON,NPN,MATCHED	80009	153-0547-00
Q228)						
Q232) ¹	153-0609-00			SEMICON DVC SE:SILICON,PNP	80009	153-0609-00
Q234)						
Q242	151-0271-00			TRANSISTOR:SILICON,PNP	80009	151-0271-00
Q248	151-0271-00			TRANSISTOR:SILICON,PNP	80009	151-0271-00
Q252	151-0221-00			TRANSISTOR:SILICON,PNP	80009	151-0221-00
Q262	151-0221-00			TRANSISTOR:SILICON,PNP	80009	151-0221-00
Q304	151-0221-00			TRANSISTOR:SILICON,PNP	80009	151-0221-00
Q308	151-0221-00			TRANSISTOR:SILICON,PNP	80009	151-0221-00
Q314	151-0221-00			TRANSISTOR:SILICON,PNP	80009	151-0221-00
Q318	151-0221-00			TRANSISTOR:SILICON,PNP	80009	151-0221-00
Q322	151-0269-00	B250000	B255714	TRANSISTOR:SILICON,NPN,SEL FROM SE3005	80009	151-0269-00
Q322	151-0471-00	B255715		TRANSISTOR:SILICON,NPN	07263	S039875
Q324	151-0269-00	B250000	B255714	TRANSISTOR:SILICON,NPN,SEL FROM SE3005	80009	151-0269-00
Q324	151-0471-00	B255715		TRANSISTOR:SILICON,NPN	07263	S039875
Q332	151-0188-00			TRANSISTOR:SILICON,PNP	01295	2N3906
Q344	151-0367-00			TRANSISTOR:SILICON,NPN,SEL FROM 3571TP	80009	151-0367-00
Q346	151-0221-00			TRANSISTOR:SILICON,PNP	80009	151-0221-00
Q352	151-0223-00			TRANSISTOR:SILICON,NPN	80009	151-0223-00
Q358	151-0223-00			TRANSISTOR:SILICON,NPN	80009	151-0223-00
Q364	151-0190-00			TRANSISTOR:SILICON,NPN	80009	151-0190-00
Q374	151-0190-00			TRANSISTOR:SILICON,NPN	80009	151-0190-00
Q382	151-0435-00			TRANSISTOR:SILICON,PNP	04713	MPS-A65
Q386	151-0301-00			TRANSISTOR:SILICON,PNP	04713	2N2907A
Q392	151-0435-00			TRANSISTOR:SILICON,PNP	04713	MPS-A65
Q396	151-0301-00			TRANSISTOR:SILICON,PNP	04713	2N2907A
Q522)	151-1042-00			SEMICON DVC SE:MATCHED PAIR FET	80009	151-1042-00
Q524)						
Q550	151-0221-00			TRANSISTOR:SILICON,PNP	80009	151-0221-00
Q552	151-0221-00			TRANSISTOR:SILICON,PNP	80009	151-0221-00
Q622)	151-1042-00			SEMICON DVC SE:MATCHED PAIR FET	80009	151-1042-00
Q624)						
Q650	151-0221-00			TRANSISTOR:SILICON,PNP	80009	151-0221-00
Q652	151-0221-00			TRANSISTOR:SILICON,PNP	80009	151-0221-00
Q672 ²	153-0597-00			SEMICON DVC SE:SILICON,PNP	80009	153-0597-00
Q678	151-0367-00			TRANSISTOR:SILICON,NPN,SEL FROM 3571TP	80009	151-0367-00
Q682 ²	153-0597-00			SEMICON DVC SE:SILICON,PNP	80009	153-0597-00
Q688	151-0367-00			TRANSISTOR:SILICON,NPN,SEL FROM 3571TP	80009	151-0367-00
Q804	151-0220-03	B250000	B251094	TRANSISTOR:SILICON,PNP	80009	151-0220-03
Q804	151-0199-00	B251095		TRANSISTOR:SILICON,PNP	27014	ST65038
Q812	151-0220-03			TRANSISTOR:SILICON,PNP	80009	151-0220-03
Q814	151-0220-03			TRANSISTOR:SILICON,PNP	80009	151-0220-03
Q822	151-0220-03			TRANSISTOR:SILICON,PNP	80009	151-0220-03
Q824	151-0220-03			TRANSISTOR:SILICON,PNP	80009	151-0220-03
Q828	151-0190-00			TRANSISTOR:SILICON,NPN	80009	151-0190-00
Q854	151-0220-03	B250000	B251094	TRANSISTOR:SILICON,PNP	80009	151-0220-03
Q854	151-0199-00	B251095		TRANSISTOR:SILICON,PNP	27014	ST65038
Q862	151-0220-03			TRANSISTOR:SILICON,PNP	80009	151-0220-03

¹Q232 and Q234 furnished as a matched pair.

²Q672 and Q682 furnished as a matched pair.

Replaceable Electrical Parts—465 Service (SN B250000-up)

Ckt No.	Tektronix Part No.	Serial/Model No. Eff	Dscont	Name & Description	Mfr Code	Mfr Part Number
Q864	151-0220-03			TRANSISTOR:SILICON,PNP	80009	151-0220-03
Q1002A,B	151-0354-00			TRANSISTOR:SILICON,PNP,DUAL	32293	ITS1200A
Q1012	151-0220-03			TRANSISTOR:SILICON,PNP	80009	151-0220-03
Q1014	151-0220-03			TRANSISTOR:SILICON,PNP	80009	151-0220-03
Q1024	151-0283-00			TRANSISTOR:SILICON,NPN	07263	S032790
Q1030	151-1025-00			TRANSISTOR:SILICON,JFE,N-CHANNEL	80009	151-1025-00
Q1036	151-0127-00			TRANSISTOR:SILICON,NPN	80009	151-0127-00
Q1038	151-0188-00			TRANSISTOR:SILICON,PNP	01295	2N3906
Q1042A,B	151-0232-00			TRANSISTOR:SILICON,NPN,DUAL	80009	151-0232-00
Q1044	151-0190-00			TRANSISTOR:SILICON,NPN	80009	151-0190-00
Q1052	151-0220-03			TRANSISTOR:SILICON,PNP	80009	151-0220-03
Q1054	151-0220-03			TRANSISTOR:SILICON,PNP	80009	151-0220-03
Q1062A,B	151-0354-00			TRANSISTOR:SILICON,PNP,DUAL	32293	ITS1200A
Q1063	151-0188-00			TRANSISTOR:SILICON,PNP	01295	2N3906
Q1072	151-0220-03			TRANSISTOR:SILICON,PNP	80009	151-0220-03
Q1074	151-0220-03			TRANSISTOR:SILICON,PNP	80009	151-0220-03
Q1084	151-0283-00			TRANSISTOR:SILICON,NPN	07263	S032790
Q1090	151-1025-00			TRANSISTOR:SILICON,JFE,N-CHANNEL	80009	151-1025-00
Q1096	151-0127-00			TRANSISTOR:SILICON,NPN	80009	151-0127-00
Q1098	151-0188-00			TRANSISTOR:SILICON,PNP	01295	2N3906
Q1140	151-0302-00			TRANSISTOR:SILICON,NPN	04713	2N2222A
Q1170	151-0302-00			TRANSISTOR:SILICON,NPN	04713	2N2222A
Q1214	151-0220-03			TRANSISTOR:SILICON,PNP	80009	151-0220-03
Q1218	151-0216-00			TRANSISTOR:SILICON,PNP	04713	MPS6523
Q1224	151-0190-02			TRANSISTOR:SILICON,NPN	80009	151-0190-02
Q1226	151-0188-00			TRANSISTOR:SILICON,PNP	01295	2N3906
Q1234	151-0190-02			TRANSISTOR:SILICON,NPN	80009	151-0190-02
Q1236	151-0188-00			TRANSISTOR:SILICON,PNP	01295	2N3906
Q1244	151-0190-00			TRANSISTOR:SILICON,NPN	80009	151-0190-00
Q1254	151-0301-00			TRANSISTOR:SILICON,PNP	04713	2N2907A
Q1262	151-0406-00			TRANSISTOR:SILICON,PNP	80009	151-0406-00
Q1266	151-0407-00			TRANSISTOR:SILICON,NPN	80009	151-0407-00
Q1274	151-0302-00			TRANSISTOR:SILICON,NPN	04713	2N2222A
Q1282	151-0406-00			TRANSISTOR:SILICON,PNP	80009	151-0406-00
Q1286	151-0407-00			TRANSISTOR:SILICON,NPN	80009	151-0407-00
Q1304	151-0190-00			TRANSISTOR:SILICON,NPN	80009	151-0190-00
Q1306	151-0190-00			TRANSISTOR:SILICON,NPN	80009	151-0190-00
Q1314	151-0220-03			TRANSISTOR:SILICON,PNP	80009	151-0220-03
Q1324	151-0190-00			TRANSISTOR:SILICON,NPN	80009	151-0190-00
Q1326	151-0190-00			TRANSISTOR:SILICON,NPN	80009	151-0190-00
Q1334	151-0220-03			TRANSISTOR:SILICON,PNP	80009	151-0220-03
Q1404	151-0126-00			TRANSISTOR:SILICON,NPN	15818	2N2484
Q1408	151-0301-00			TRANSISTOR:SILICON,PNP	04713	2N2907A
Q1413	151-0188-00			TRANSISTOR:SILICON,PNP	01295	2N3906
Q1414	151-0190-00			TRANSISTOR:SILICON,NPN	80009	151-0190-00
Q1416	151-0136-00			TRANSISTOR:SILICON,NPN	02735	35495
Q1418	151-0140-00			TRANSISTOR:SILICON,NPN	80009	151-0140-00
Q1466	151-0223-00			TRANSISTOR:SILICON,NPN	80009	151-0223-00
Q1472	151-0188-00			TRANSISTOR:SILICON,PNP	01295	2N3906
Q1474	151-0407-00			TRANSISTOR:SILICON,NPN	80009	151-0407-00
Q1478	151-0406-00			TRANSISTOR:SILICON,PNP	80009	151-0406-00
Q1516	151-0311-01			TRANSISTOR:SILICON,NPN	04713	MJE340
Q1518	151-0347-00			TRANSISTOR:SILICON,NPN	80009	151-0347-00

Replaceable Electrical Parts—465 Service (SN B250000-up)

Ckt No.	Tektronix Part No.	Serial/Model No. Eff	Dscont	Name & Description	Mfr Code	Mfr Part Number
Q1532	151-0347-00			TRANSISTOR:SILICON,NPN	80009	151-0347-00
Q1534	151-0436-00			TRANSISTOR:SILICON,NPN	80009	151-0436-00
Q1536	151-0347-00			TRANSISTOR:SILICON,NPN	80009	151-0347-00
Q1544	151-0302-00			TRANSISTOR:SILICON,NPN	04713	2N2222A
Q1546	151-0349-00			TRANSISTOR:SILICON,NPN,SEL FROM MJE2801	80009	151-0349-00
Q1548	151-0302-00			TRANSISTOR:SILICON,NPN	04713	2N2222A
Q1556	151-0390-00			TRANSISTOR:SILICON,NPN	80009	151-0390-00
Q1558	151-0302-00			TRANSISTOR:SILICON,NPN	04713	2N2222A
Q1564	151-0302-00			TRANSISTOR:SILICON,NPN	04713	2N2222A
Q1566	151-0349-00			TRANSISTOR:SILICON,NPN,SEL FROM MJE2801	80009	151-0349-00
Q1568	151-0302-00			TRANSISTOR:SILICON,NPN	04713	2N2222A
Q1570	151-0390-00			TRANSISTOR:SILICON,NPN	80009	151-0390-00
Q1582	151-0302-00			TRANSISTOR:SILICON,NPN	04713	2N2222A
Q1588	151-0302-00			TRANSISTOR:SILICON,NPN	04713	2N2222A
Q1590	151-0342-00			TRANSISTOR:SILICON,PNP	80009	151-0342-00
Q1594	151-0342-00			TRANSISTOR:SILICON,PNP	80009	151-0342-00
Q1598	151-0164-00			TRANSISTOR:SILICON,PNP	80009	151-0164-00
Q1698	151-0301-00			TRANSISTOR:SILICON,PNP	04713	2N2907A
Q4402	151-0212-00			TRANSISTOR:SILICON,NPN	80009	151-0212-00
Q4406	151-0212-00			TRANSISTOR:SILICON,NPN	80009	151-0212-00
Q4412	151-0212-00			TRANSISTOR:SILICON,NPN	80009	151-0212-00
Q4416	151-0212-00			TRANSISTOR:SILICON,NPN	80009	151-0212-00
Q4432	151-0212-00			TRANSISTOR:SILICON,NPN	80009	151-0212-00
Q4442	151-0212-00			TRANSISTOR:SILICON,NPN	80009	151-0212-00
Q4462	151-0434-00			TRANSISTOR:SILICON,PNP	80009	151-0434-00
Q4468	151-0448-00			TRANSISTOR:SILICON,NPN	80009	151-0448-00
Q4472	151-0434-00			TRANSISTOR:SILICON,PNP	80009	151-0434-00
Q4478	151-0448-00			TRANSISTOR:SILICON,NPN	80009	151-0448-00
Q4482	151-0446-00			TRANSISTOR:SILICON,NPN	80009	151-0446-00
Q4492	151-0446-00			TRANSISTOR:SILICON,NPN	80009	151-0446-00
R1	315-0510-00			RES.,FXD,CMPSN:51 OHM,5%,0.25W	01121	CB5105
R3	317-0047-00			RES.,FXD,CMPSN:4.7 OHM,5%,0.125W	01121	BB47G5
R4	316-0105-00			RES.,FXD,CMPSN:1M OHM,10%,0.25W	01121	CB1051
R6	317-0101-00			RES.,FXD,CMPSN:100 OHM,5%,0.125W	01121	BB1015
R15	321-0481-00			RES.,FXD,FILM:1M OHM,1%,0.125W	91637	MFF1816G10003F
R16	316-0474-00			RES.,FXD,CMPSN:470K OHM,10%,0.25W	01121	CB4741
R18	315-0361-00			RES.,FXD,CMPSN:360 OHM,5%,0.25W	01121	CB3615
R21	315-0470-00			RES.,FXD,CMPSN:47 OHM,5%,0.25W	01121	CB4705
R22	321-0030-02			RES.,FXD,FILM:20 OHM,0.5%,0.125W	91637	LFF18D20R00D
R23	321-0030-02			RES.,FXD,FILM:20 OHM,0.5%,0.125W	91637	LFF18D20R00D
R25	311-1227-00			RES.,VAR,NONWIR:5K OHM,20%,0.50W	32997	3386F-T04-502
R26	315-0123-00			RES.,FXD,CMPSN:12K OHM,5%,0.25W	01121	CB1235
R27	315-0151-00			RES.,FXD,CMPSN:150 OHM,5%,0.25W	01121	CB1515
R32	321-0208-00			RES.,FXD,FILM:1.43K OHM,1%,0.125W	91637	MFF1816G14300F
R33	321-0097-00			RES.,FXD,FILM:100 OHM,1%,0.125W	91637	MFF1816G100R0F
R34 ¹	315-0434-00			RES.,FXD,CMPSN:430K OHM,5%,0.25W	01121	CB4345
R35	315-0104-00			RES.,FXD,CMPSN:100K OHM,5%,0.25W	01121	CB1045
R36	321-0208-00			RES.,FXD,FILM:1.43K OHM,1%,0.125W	91637	MFF1816G14300F
R37	315-0621-00			RES.,FXD,CMPSN:620 OHM,5%,0.25W	01121	CB6215
R38	315-0621-00			RES.,FXD,CMPSN:620 OHM,5%,0.25W	01121	CB6215
R39	316-0101-00			RES.,FXD,CMPSN:100 OHM,10%,0.25W	01121	CB1011
R41	321-0190-00			RES.,FXD,FILM:931 OHM,1%,0.125W	91637	MFF1816G931R0F
R42	316-0101-00			RES.,FXD,CMPSN:100 OHM,10%,0.25W	01121	CB1011

¹Not included when 670-3023-00, -01 and -02 VERT OUTPUT Board is used.

Replaceable Electrical Parts—465 Service (SN B25000-up)

Ckt No.	Tektronix Part No.	Serial/Model No. Eff	Dscont	Name & Description	Mfr Code	Mfr Part Number
R43	321-0190-00			RES.,FXD,FILM:931 OHM,1%,0.125W	91637	MFF1816G931ROF
R44	321-0098-01			RES.,FXD,FILM:102 OHM,0.5%,0.125W	91637	MFF1816G102ROD
R45	321-0098-01			RES.,FXD,FILM:102 OHM,0.5%,0.125W	91637	MFF1816G102ROD
R46	321-0126-01			RES.,FXD,FILM:200 OHM,0.5%,0.125W	91637	MFF1816G200ROD
R47	311-0635-00			RES.,VAR,NONWIR:1K OHM,10%,0.50W	80740	62-56-3
R48	311-0635-00			RES.,VAR,NONWIR:1K OHM,10%,0.50W	80740	62-56-3
R49	321-0080-01			RES.,FXD,FILM:66.5 OHM,0.5%,0.125W	91637	MFF1816G66R50D
R51	315-0510-00			RES.,FXD,CMPSN:51 OHM,5%,0.25W	01121	CB5105
R53	317-0047-00			RES.,FXD,CMPSN:4.7 OHM,5%,0.125W	01121	BB47G5
R54	316-0105-00			RES.,FXD,CMPSN:1M OHM,10%,0.25W	01121	CB1051
R56	317-0101-00			RES.,FXD,CMPSN:100 OHM,5%,0.125W	01121	BB1015
R65	321-0481-00			RES.,FXD,FILM:1M OHM,1%,0.125W	91637	MFF1816G10003F
R66	316-0474-00			RES.,FXD,CMPSN:470K OHM,10%,0.25W	01121	CB4741
R68	315-0361-00			RES.,FXD,CMPSN:360 OHM,5%,0.25W	01121	CB3615
R71	315-0470-00			RES.,FXD,CMPSN:47 OHM,5%,0.25W	01121	CB4705
R72	321-0030-02			RES.,FXD,FILM:20 OHM,0.5%,0.125W	91637	LFF18D20R00D
R73	321-0030-02			RES.,FXD,FILM:20 OHM,0.5%,0.125W	91637	LFF18D20R00D
R75	311-1227-00			RES.,VAR,NONWIR:5K OHM,20%,0.50W	32997	3386F-T04-502
R76	315-0123-00			RES.,FXD,CMPSN:12K OHM,5%,0.25W	01121	CB1235
R77	315-0151-00			RES.,FXD,CMPSN:150 OHM,5%,0.25W	01121	CB1515
R82	321-0208-00			RES.,FXD,FILM:1.43K OHM,1%,0.125W	91637	MFF1816G14300F
R83	321-0097-00			RES.,FXD,FILM:100 OHM,1%,0.125W	91637	MFF1816G100ROF
R84 ¹	315-0434-00			RES.,FXD,CMPSN:430K OHM,5%,0.25W	01121	CB4345
R85	315-0104-00			RES.,FXD,CMPSN:100K OHM,5%,0.25W	01121	CB1045
R86	321-0208-00			RES.,FXD,FILM:1.43K OHM,1%,0.125W	91637	MFF1816G14300F
R87	315-0621-00			RES.,FXD,CMPSN:620 OHM,5%,0.25W	01121	CB6215
R88	315-0621-00			RES.,FXD,CMPSN:620 OHM,5%,0.25W	01121	CB6215
R91	321-0190-00			RES.,FXD,FILM:931 OHM,1%,0.125W	91637	MFF1816G931ROF
R92	316-0101-00			RES.,FXD,CMPSN:100 OHM,10%,0.25W	01121	CB1011
R93	321-0190-00			RES.,FXD,FILM:931 OHM,1%,0.125W	91637	MFF1816G931ROF
R94	321-0098-01			RES.,FXD,FILM:102 OHM,0.5%,0.125W	91637	MFF1816G102ROD
R95	321-0098-01			RES.,FXD,FILM:102 OHM,0.5%,0.125W	91637	MFF1816G102ROD
R96	321-0126-01			RES.,FXD,FILM:200 OHM,0.5%,0.125W	91637	MFF1816G200ROD
R97	311-0635-00			RES.,VAR,NONWIR:1K OHM,10%,0.50W	80740	62-56-3
R98	311-0635-00			RES.,VAR,NONWIR:1K OHM,10%,0.50W	80740	62-56-3
R99	321-0080-01			RES.,FXD,FILM:66.5 OHM,0.5%,0.125W	91637	MFF1816G66R50D
R101	315-0682-00			RES.,FXD,CMPSN:6.8K OHM,5%,0.25W	01121	CB6825
R102	321-0204-00			RES.,FXD,FILM:1.3K OHM,1%,0.125W	91637	MFF1816G13000F
R103	321-0087-00			RES.,FXD,FILM:78.7 OHM,1%,0.125W	91637	MFF1816G78R70F
R104	321-0204-00			RES.,FXD,FILM:1.3K OHM,1%,0.125W	91637	MFF1816G13000F
R105	311-1226-00			RES.,VAR,NONWIR:2.5K OHM,20%,0.50W	32997	3386F-T04-252
R106	315-0301-00			RES.,FXD,CMPSN:300 OHM,5%,0.25W	01121	CB3015
R107	315-0270-00			RES.,FXD,CMPSN:27 OHM,5%,0.25W	01121	CB2705
R108	315-0301-00			RES.,FXD,CMPSN:300 OHM,5%,0.25W	01121	CB3015
R109	315-0270-00			RES.,FXD,CMPSN:27 OHM,5%,0.25W	01121	CB2705
R111	321-0026-00			RES.,FXD,FILM:18.2 OHM,1%,0.125W	91637	MFF1816G18R20F
R112 ²	311-1364-00			RES.,VAR,NONWIR:1K OHM,10%,0.50W	01121	10M821
R113	321-0026-00			RES.,FXD,FILM:18.2 OHM,1%,0.125W	91637	MFF1816G18R20F
R114	315-0103-00			RES.,FXD,CMPSN:10K OHM,5%,0.25W	01121	CB1035
R115	311-1228-00			RES.,VAR,NONWIR:10K OHM,20%,0.50W	32997	3386F-T04-103
R116	315-0123-00			RES.,FXD,CMPSN:12K OHM,5%,0.25W	01121	CB1235
R117	321-0085-00			RES.,FXD,FILM:75 OHM,1%,0.125W	91637	MFF1816G75R00F
R118	311-1225-00			RES.,VAR,NONWIR:1K OHM,20%,0.50W	32997	3386F-T04-102

¹Not included when 670-3023-00, -01 and -02 VERT OUTPUT Board is used.

²Furnished as a unit with S112.

Replaceable Electrical Parts—465 Service (SN B250000-up)

Ckt No.	Tektronix Part No.	Serial/Model No. Eff	Dscont	Name & Description	Mfr Code	Mfr Part Number
R119	321-0085-00			RES.,FXD,FILM:75 OHM,1%,0.125W	91637	MFF1816G75R00F
R120	311-1007-00			RES.,VAR,NONWIR:20 OHM,20%,0.50W	73138	82-38-0
R121	321-0064-00			RES.,FXD,FILM:45.3 OHM,1%,0.125W	91637	MFF1816G45R30F
R122	311-1224-00			RES.,VAR,NONWIR:500 OHM,20%,0.50W	32997	3386F-T04-501
R123	321-0055-00			RES.,FXD,FILM:36.5 OHM,1%,0.125W	91637	MFF1816G36R50F
R125	316-0101-00			RES.,FXD,CMPSN:100 OHM,10%,0.25W	01121	CB1011
R127	321-0122-00			RES.,FXD,FILM:182 OHM,1%,0.125W	91637	MFF1816G182R0F
R128	321-0122-00			RES.,FXD,FILM:182 OHM,1%,0.125W	91637	MFF1816G182R0F
R130	321-0138-00			RES.,FXD,FILM:267 OHM,1%,0.125W	91637	MFF1816G267R0F
R132	321-0198-00			RES.,FXD,FILM:1.13K OHM,1%,0.125W	91637	MFF1816G11300F
R133	321-0097-00			RES.,FXD,FILM:100 OHM,1%,0.125W	91637	MFF1816G100R0F
R134	321-0198-00			RES.,FXD,FILM:1.13K OHM,1%,0.125W	91637	MFF1816G11300F
R135	316-0101-00			RES.,FXD,CMPSN:100 OHM,10%,0.25W	01121	CB1011
R136	315-0621-00			RES.,FXD,CMPSN:620 OHM,5%,0.25W	01121	CB6215
R137	316-0101-00			RES.,FXD,CMPSN:100 OHM,10%,0.25W	01121	CB1011
R138	315-0621-00			RES.,FXD,CMPSN:620 OHM,5%,0.25W	01121	CB6215
R141	316-0390-00			RES.,FXD,CMPSN:39 OHM,10%,0.25W	01121	CB3901
R142	315-0391-00			RES.,FXD,CMPSN:390 OHM,5%,0.25W	01121	CB3915
R143	321-0200-00			RES.,FXD,FILM:1.18K OHM,1%,0.125W	91637	MFF1816G11800F
R144	321-0084-00			RES.,FXD,FILM:73.2 OHM,1%,0.125W	91637	MFF1816G73R20F
R145	315-0100-00			RES.,FXD,CMPSN:10 OHM,5%,0.25W	01121	CB1005
R146	321-0200-00			RES.,FXD,FILM:1.18K OHM,1%,0.125W	91637	MFF1816G11800F
R147	316-0390-00			RES.,FXD,CMPSN:39 OHM,10%,0.25W	01121	CB3901
R149	311-1225-00			RES.,VAR,NONWIR:1K OHM,20%,0.50W	32997	3386F-T04-102
R151	315-0331-00			RES.,FXD,CMPSN:330 OHM,5%,0.25W	01121	CB3315
R152	321-0160-00			RES.,FXD,FILM:453 OHM,1%,0.125W	91637	MFF1816G453R0F
R154	321-0201-00			RES.,FXD,FILM:1.21K OHM,1%,0.125W	91637	MFF1816G12100F
R155	311-1224-00			RES.,VAR,NONWIR:500 OHM,20%,0.50W	32997	3386F-T04-501
R161	315-0331-00			RES.,FXD,CMPSN:330 OHM,5%,0.25W	01121	CB3315
R162	321-0064-00			RES.,FXD,FILM:45.3 OHM,1%,0.125W	91637	MFF1816G45R30F
R164	315-0751-00			RES.,FXD,CMPSN:750 OHM,5%,0.25W	01121	CB7515
R165	315-0331-00			RES.,FXD,CMPSN:330 OHM,5%,0.25W	01121	CB3315
R168	321-0064-00			RES.,FXD,FILM:45.3 OHM,1%,0.125W	91637	MFF1816G45R30F
R169	316-0101-00			RES.,FXD,CMPSN:100 OHM,10%,0.25W	01121	CB1011
R201	315-0562-00			RES.,FXD,CMPSN:5.6K OHM,5%,0.25W	01121	CB5625
R202	321-0204-00			RES.,FXD,FILM:1.3K OHM,1%,0.125W	91637	MFF1816G13000F
R203	321-0087-00			RES.,FXD,FILM:78.7 OHM,1%,0.125W	91637	MFF1816G78R70F
R204	321-0204-00			RES.,FXD,FILM:1.3K OHM,1%,0.125W	91637	MFF1816G13000F
R205	311-1226-00			RES.,VAR,NONWIR:2.5K OHM,20%,0.50W	32997	3386F-T04-252
R206	315-0301-00			RES.,FXD,CMPSN:300 OHM,5%,0.25W	01121	CB3015
R207	315-0270-00			RES.,FXD,CMPSN:27 OHM,5%,0.25W	01121	CB2705
R208	315-0301-00			RES.,FXD,CMPSN:300 OHM,5%,0.25W	01121	CB3015
R209	315-0270-00			RES.,FXD,CMPSN:27 OHM,5%,0.25W	01121	CB2705
R211	321-0026-00			RES.,FXD,FILM:18.2 OHM,1%,0.125W	91637	MFF1816G18R20F
R212 ¹	311-1364-00			RES.,VAR,NONWIR:1K OHM,10%,0.50W	01121	10M821
R213	321-0026-00			RES.,FXD,FILM:18.2 OHM,1%,0.125W	91637	MFF1816G18R20F
R214	315-0103-00			RES.,FXD,CMPSN:10K OHM,5%,0.25W	01121	CB1035
R215	311-1228-00			RES.,VAR,NONWIR:10K OHM,20%,0.50W	32997	3386F-T04-103
R217	321-0085-00			RES.,FXD,FILM:75 OHM,1%,0.125W	91637	MFF1816G75R00F
R218	311-1225-00			RES.,VAR,NONWIR:1K OHM,20%,0.50W	32997	3386F-T04-102
R219	321-0085-00			RES.,FXD,FILM:75 OHM,1%,0.125W	91637	MFF1816G75R00F
R220	311-1007-00			RES.,VAR,NONWIR:20 OHM,20%,0.50W	73138	82-38-0
R221	321-0064-00			RES.,FXD,FILM:45.3 OHM,1%,0.125W	91637	MFF1816G45R30F

¹Furnished as a unit with S212.

Replaceable Electrical Parts—465 Service (SN B250000-up)

Ckt No.	Tektronix Part No.	Serial/Model No. Eff	Dscont	Name & Description	Mfr Code	Mfr Part Number
R222	316-0101-00			RES.,FXD,CMPSN:100 OHM,10%,0.25W	01121	CB1011
R223	321-0055-00			RES.,FXD,FILM:36.5 OHM,1%,0.125W	91637	MFF1816G36R50F
R224	316-0103-00			RES.,FXD,CMPSN:10K OHM,10%,0.25W	01121	CB1031
R225	316-0103-00			RES.,FXD,CMPSN:10K OHM,10%,0.25W	01121	CB1031
R226	316-0103-00			RES.,FXD,CMPSN:10K OHM,10%,0.25W	01121	CB1031
R227	321-0122-00			RES.,FXD,FILM:182 OHM,1%,0.125W	91637	MFF1816G182ROF
R228	321-0122-00			RES.,FXD,FILM:182 OHM,1%,0.125W	91637	MFF1816G182ROF
R229	316-0101-00			RES.,FXD,CMPSN:100 OHM,10%,0.25W	01121	CB1011
R230	321-0138-00			RES.,FXD,FILM:267 OHM,1%,0.125W	91637	MFF1816G267ROF
R232	321-0198-00			RES.,FXD,FILM:1.13K OHM,1%,0.125W	91637	MFF1816G11300F
R233	321-0097-00			RES.,FXD,FILM:100 OHM,1%,0.125W	91637	MFF1816G100ROF
R234	321-0198-00			RES.,FXD,FILM:1.13K OHM,1%,0.125W	91637	MFF1816G11300F
R235	316-0101-00			RES.,FXD,CMPSN:100 OHM,10%,0.25W	01121	CB1011
R236	315-0621-00			RES.,FXD,CMPSN:620 OHM,5%,0.25W	01121	CB6215
R237	316-0101-00			RES.,FXD,CMPSN:100 OHM,10%,0.25W	01121	CB1011
R238	315-0621-00			RES.,FXD,CMPSN:620 OHM,5%,0.25W	01121	CB6215
R241	316-0390-00			RES.,FXD,CMPSN:39 OHM,10%,0.25W	01121	CB3901
R242	315-0391-00			RES.,FXD,CMPSN:390 OHM,5%,0.25W	01121	CB3915
R243	321-0200-00			RES.,FXD,FILM:1.18K OHM,1%,0.125W	91637	MFF1816G11800F
R244	321-0084-00			RES.,FXD,FILM:73.2 OHM,1%,0.125W	91637	MFF1816G73R20F
R245	315-0270-00			RES.,FXD,CMPSN:27 OHM,5%,0.25W	01121	CB2705
R246	321-0200-00			RES.,FXD,FILM:1.18K OHM,1%,0.125W	91637	MFF1816G11800F
R247	316-0390-00			RES.,FXD,CMPSN:39 OHM,10%,0.25W	01121	CB3901
R249	311-1225-00			RES.,VAR,NONWIR:1K OHM,20%,0.50W	32997	3386F-T04-102
R251	315-0331-00			RES.,FXD,CMPSN:330 OHM,5%,0.25W	01121	CB3315
R252	321-0160-00			RES.,FXD,FILM:453 OHM,1%,0.125W	91637	MFF1816G453ROF
R254	321-0201-00			RES.,FXD,FILM:1.21K OHM,1%,0.125W	91637	MFF1816G12100F
R255	311-1224-00			RES.,VAR,NONWIR:500 OHM,20%,0.50W	32997	3386F-T04-501
R261	315-0751-00			RES.,FXD,CMPSN:750 OHM,5%,0.25W	01121	CB7515
R262	321-0064-00			RES.,FXD,FILM:45.3 OHM,1%,0.125W	91637	MFF1816G45R30F
R301	311-1311-00			RES.,VAR,NONWIR:1K OHM,20%,1W	01121	10M655
R302	321-0236-00			RES.,FXD,FILM:2.8K OHM,1%,0.125W	91637	MFF1816G28000F
R311	311-1311-00			RES.,VAR,NONWIR:1K OHM,20%,1W	01121	10M655
R312	321-0236-00			RES.,FXD,FILM:2.8K OHM,1%,0.125W	91637	MFF1816G28000F
R321	321-0186-00			RES.,FXD,FILM:845 OHM,1%,0.125W	91637	MFF1816G845ROF
R322	321-0186-00			RES.,FXD,FILM:845 OHM,1%,0.125W	91637	MFF1816G845ROF
R323	321-0157-00			RES.,FXD,FILM:422 OHM,1%,0.125W	91637	MFF1816G422ROF
R324	321-0157-00			RES.,FXD,FILM:422 OHM,1%,0.125W	91637	MFF1816G422ROF
R325	321-0114-00			RES.,FXD,FILM:150 OHM,1%,0.125W	91637	MFF1816G150ROF
R326	323-0175-00			RES.,FXD,FILM:649 OHM,1%,0.50W	75042	CECT0-6490F
R327	321-0114-00			RES.,FXD,FILM:150 OHM,1%,0.125W	91637	MFF1816G150ROF
R331	323-0124-00			RES.,FXD,FILM:191 OHM,1%,0.50W	91637	MFF1226G191ROF
R332	316-0221-00			RES.,FXD,CMPSN:220 OHM,10%,0.25W	01121	CB2211
R334	316-0391-00			RES.,FXD,CMPSN:390 OHM,10%,0.25W	01121	CB3911
R335	321-0065-00			RES.,FXD,FILM:46.4 OHM,1%,0.125W	91637	MFF1816G46R40F
R336	321-0065-00			RES.,FXD,FILM:46.4 OHM,1%,0.125W	91637	MFF1816G46R40F
R340	311-1222-00			RES.,VAR,NONWIR:100 OHM,20%,0.50W	32997	3386F-T04-101
R341	323-0168-00			RES.,FXD,FILM:549 OHM,1%,0.50W	75042	CECT0-5490F
R342	321-0041-00			RES.,FXD,FILM:26.1 OHM,1%,0.125W	91637	MFF1816G26R10F
R343	315-0101-00			RES.,FXD,CMPSN:100 OHM,5%,0.25W	01121	CB1015
R344	321-0093-00			RES.,FXD,FILM:90.9 OHM,1%,0.125W	91637	MFF1816G90R90F
R345	321-0197-00			RES.,FXD,FILM:1.1K OHM,1%,0.125W	91637	MFF1816G11000F
R346	321-0164-00			RES.,FXD,FILM:499 OHM,1%,0.125W	91637	MFF1816G499ROF

Replaceable Electrical Parts—465 Service (SN B25000-up)

Ckt No.	Tektronix Part No.	Serial/Model No. Eff	Dscont	Name & Description	Mfr Code	Mfr Part Number
R347	321-0095-00			RES.,FXD,FILM:95.3 OHM,1%,0.125W	91637	MFF1816G95R30F
R348	321-0114-00			RES.,FXD,FILM:150 OHM,1%,0.125W	91637	MFF1816G150R0F
R349	321-0068-00			RES.,FXD,FILM:49.9 OHM,1%,0.125W	91637	MFF1816G49R90F
R351	315-0752-00			RES.,FXD,CMPSN:7.5K OHM,5%,0.25W	01121	CB7525
R352	321-0089-00			RES.,FXD,FILM:82.5 OHM,1%,0.125W	91637	MFF1816G82R50F
R356	315-0683-00			RES.,FXD,CMPSN:68K OHM,5%,0.25W	01121	CB6835
R357	316-0101-00			RES.,FXD,CMPSN:100 OHM,10%,0.25W	01121	CB1011
R358	315-0202-00			RES.,FXD,CMPSN:2K OHM,5%,0.25W	01121	CB2025
R359 ¹	315-0272-00			RES.,FXD,CMPSN:2.7K OHM,5%,0.25W	01121	CB2725
R360 ¹						
R361	321-0193-00			RES.,FXD,FILM:1K OHM,1%,0.125W	91637	MFF1816G10000F
R362 ¹	321-0158-00			RES.,FXD,FILM:432 OHM,1%,0.125W	91637	MFF1816G432R0F
R363 ¹						
R364	321-0212-00			RES.,FXD,FILM:1.58K OHM,1%,0.125W	91637	MFF1816G15800F
R365	321-0229-00			RES.,FXD,FILM:2.37K OHM,1%,0.125W	91637	MFF1816G23700F
R367	315-0201-00			RES.,FXD,CMPSN:200 OHM,5%,0.25W	01121	CB2015
R368	321-0122-00			RES.,FXD,FILM:182 OHM,1%,0.125W	91637	MFF1816G182R0F
R370	315-0123-00	B250000	B279999	RES.,FXD,CMPSN:12K OHM,5%,0.25W	01121	CB1235
R370	315-0183-00	B280000		RES.,FXD,CMPSN:18K OHM,5%,0.25W	01121	CB1835
R371	321-0193-00			RES.,FXD,FILM:1K OHM,1%,0.125W	91637	MFF1816G10000F
R372	321-0158-00			RES.,FXD,FILM:432 OHM,1%,0.125W	91637	MFF1816G432R0F
R374	321-0212-00			RES.,FXD,FILM:1.58K OHM,1%,0.125W	91637	MFF1816G15800F
R375	321-0229-00			RES.,FXD,FILM:2.37K OHM,1%,0.125W	91637	MFF1816G23700F
R376	315-0201-00			RES.,FXD,CMPSN:200 OHM,5%,0.25W	01121	CB2015
R378	321-0122-00			RES.,FXD,FILM:182 OHM,1%,0.125W	91637	MFF1816G182R0F
R381	316-0152-00			RES.,FXD,CMPSN:1.5K OHM,10%,0.25W	01121	CB1521
R382	315-0473-00	XB251725		RES.,FXD,CMPSN:47K OHM,5%,0.25W	01121	CB4735
R383	316-0222-00			RES.,FXD,CMPSN:2.2K OHM,10%,0.25W	01121	CB2221
R384	316-0822-00			RES.,FXD,CMPSN:8.2K OHM,10%,0.25W	01121	CB8221
R388	316-0154-00			RES.,FXD,CMPSN:150K OHM,10%,0.25W	01121	CB1541
R389	316-0154-00			RES.,FXD,CMPSN:150K OHM,10%,0.25W	01121	CB1541
R391	316-0152-00			RES.,FXD,CMPSN:1.5K OHM,10%,0.25W	01121	CB1521
R392	315-0473-00	XB251725		RES.,FXD,CMPSN:47K OHM,5%,0.25W	01121	CB4735
R393	316-0222-00			RES.,FXD,CMPSN:2.2K OHM,10%,0.25W	01121	CB2221
R394	316-0822-00			RES.,FXD,CMPSN:8.2K OHM,10%,0.25W	01121	CB8221
R400	311-1139-00			RES.,VAR, NONWIR:500 OHM,20%,0.50W	73138	72XW-43-0-501M
R401	321-0068-00			RES.,FXD,FILM:49.9 OHM,1%,0.125W	91637	MFF1816G49R90F
R402	321-0104-00			RES.,FXD,FILM:118 OHM,1%,0.125W	91637	MFF1816G118R0F
R403	315-0390-00			RES.,FXD,CMPSN:39 OHM,5%,0.25W	01121	CB3905
R404	321-0070-00			RES.,FXD,FILM:52.3 OHM,1%,0.125W	91637	MFF1816G52R30F
R405	321-0187-00			RES.,FXD,FILM:866 OHM,1%,0.125W	91637	MFF1816G866R0F
R407	321-0175-00			RES.,FXD,FILM:649 OHM,1%,0.125W	91637	MFF1816G649R0F
R409	321-0178-00			RES.,FXD,FILM:698 OHM,1%,0.125W	91637	MFF1816G698R0F
R411	321-0068-00			RES.,FXD,FILM:49.9 OHM,1%,0.125W	91637	MFF1816G49R90F
R414	321-0070-00			RES.,FXD,FILM:52.3 OHM,1%,0.125W	91637	MFF1816G52R30F
R415	315-0100-00			RES.,FXD,CMPSN:10 OHM,5%,0.25W	01121	CB1005
R417	321-0175-00			RES.,FXD,FILM:649 OHM,1%,0.125W	91637	MFF1816G649R0F
R419	323-0071-00			RES.,FXD,FILM:53.6 OHM,1%,0.50W	75042	CECT0-53R60F
R421	315-0620-00			RES.,FXD,CMPSN:62 OHM,5%,0.25W	01121	CB6205
R423	311-0609-00			RES.,VAR, NONWIR:2K OHM,10%,0.50W	80740	62-57-3
R424	311-1239-00			RES.,VAR, NONWIR:2.5K OHM,10%,0.50W	73138	72X-76-0252K
R426	321-0423-00			RES.,FXD,FILM:249K OHM,1%,0.125W	91637	MFF1816G24902F
R427	323-0144-00			RES.,FXD,FILM:309 OHM,1%,0.50W	75042	CECT0-3090F

¹See DM44 manual.

Replaceable Electrical Parts—465 Service (SN B25000-up)

Ckt No.	Tektronix Part No.	Serial/Model No. Eff	Dscont	Name & Description	Mfr Code	Mfr Part Number
R428	323-0144-00			RES., FXD, FILM:309 OHM, 1%, 0.50W	75042	CECT0-3090F
R429	311-1236-00			RES., VAR, NONWIR:250 OHM, 10%, 0.50W	73138	72X-22-0-251K
R433	311-1138-00			RES., VAR, NONWIR:1K OHM, 20%, 0.50W	73138	72XW-44-0-102
R434	311-1138-00			RES., VAR, NONWIR:1K OHM, 20%, 0.50W	73138	72XW-44-0-102
R437	323-0158-00			RES., FXD, FILM:432 OHM, 1%, 0.50W	75042	CECT0-4320F
R438	323-0158-00			RES., FXD, FILM:432 OHM, 1%, 0.50W	75042	CECT0-4320F
R440	321-0080-00			RES., FXD, FILM:66.5 OHM, 1%, 0.125W	91637	MFF1816G66R50F
R441	321-0064-00			RES., FXD, FILM:45.3 OHM, 1%, 0.125W	91637	MFF1816G45R30F
R442	311-1139-00			RES., VAR, NONWIR:500 OHM, 20%, 0.50W	73138	72XW-43-0-501M
R443	321-0193-00			RES., FXD, FILM:1K OHM, 1%, 0.125W	91637	MFF1816G10000F
R444	315-0302-00			RES., FXD, CMPSN:3K OHM, 5%, 0.25W	01121	CB3025
R445	315-0472-00			RES., FXD, CMPSN:4.7K OHM, 5%, 0.25W	01121	CB4725
R446	321-0070-00			RES., FXD, FILM:52.3 OHM, 1%, 0.125W	91637	MFF1816G52R30F
R447	321-0070-00			RES., FXD, FILM:52.3 OHM, 1%, 0.125W	91637	MFF1816G52R30F
R448	322-0662-00			RES., FXD, FILM:334 OHM, 1%, 0.25W	75042	CEBT0-3340F
R449	322-0180-00			RES., FXD, FILM:732 OHM, 1%, 0.25W	75042	CEBT0-7320F
R451	321-0196-00			RES., FXD, FILM:1.07K OHM, 1%, 0.125W	91637	MFF1816G10700F
R452	315-0101-00			RES., FXD, CMPSN:100 OHM, 5%, 0.25W	01121	CB1015
R453	321-0223-00			RES., FXD, FILM:2.05K OHM, 1%, 0.125W	91637	MFF1816G20500F
R454	321-0164-00			RES., FXD, FILM:499 OHM, 1%, 0.125W	91637	MFF1816G499R0F
R455	311-1138-00			RES., VAR, NONWIR:1K OHM, 20%, 0.50W	73138	72XW-44-0-102
R457	315-0201-00			RES., FXD, CMPSN:200 OHM, 5%, 0.25W	01121	CB2015
R461	317-0101-00			RES., FXD, CMPSN:100 OHM, 5%, 0.125W	01121	BB1015
R464	310-0700-00			RES., FXD, WW:430 OHM, 1%, 4W	80009	310-0700-00
R471	317-0101-00			RES., FXD, CMPSN:100 OHM, 5%, 0.125W	01121	BB1015
R474	310-0700-00			RES., FXD, WW:430 OHM, 1%, 4W	80009	310-0700-00
R502	315-0754-00			RES., FXD, CMPSN:750K OHM, 5%, 0.25W	01121	CB7545
R503	315-0334-00			RES., FXD, CMPSN:330K OHM, 5%, 0.25W	01121	CB3345
R507	321-0068-00			RES., FXD, FILM:49.9 OHM, 1%, 0.125W	91637	MFF1816G49R90F
R508	321-0068-00			RES., FXD, FILM:49.9 OHM, 1%, 0.125W	91637	MFF1816G49R90F
R509	321-0068-00			RES., FXD, FILM:49.9 OHM, 1%, 0.125W	91637	MFF1816G49R90F
R511	316-0104-00			RES., FXD, CMPSN:100K OHM, 10%, 0.25W	01121	CB1041
R512	316-0563-00			RES., FXD, CMPSN:56K OHM, 10%, 0.25W	01121	CB5631
R516	321-0481-00			RES., FXD, FILM:1M OHM, 1%, 0.125W	91637	MFF1816G10003F
R517	316-0101-00			RES., FXD, CMPSN:100 OHM, 10%, 0.25W	01121	CB1011
R518	316-0101-00			RES., FXD, CMPSN:100 OHM, 10%, 0.25W	01121	CB1011
R522	316-0101-00			RES., FXD, CMPSN:100 OHM, 10%, 0.25W	01121	CB1011
R523	316-0150-00			RES., FXD, CMPSN:15 OHM, 10%, 0.25W	01121	CB1501
R524	316-0150-00			RES., FXD, CMPSN:15 OHM, 10%, 0.25W	01121	CB1501
R525	316-0101-00			RES., FXD, CMPSN:100 OHM, 10%, 0.25W	01121	CB1011
R526	317-0102-00	XB292865		RES., FXD, CMPSN:1K OHM, 5%, 0.125W	01121	BB1025
R527	321-0209-00			RES., FXD, FILM:1.47K OHM, 1%, 0.125W	91637	MFF1816G14700F
R528	315-0390-00			RES., FXD, CMPSN:39 OHM, 5%, 0.25W	01121	CB3905
R529	321-0209-00			RES., FXD, FILM:1.47K OHM, 1%, 0.125W	91637	MFF1816G14700F
R530 ¹	311-1192-00			RES., VAR, NONWIR:10K OHM, 20%, 1W	71590	BR-232-001
R531	316-0681-00			RES., FXD, CMPSN:680 OHM, 10%, 0.25W	01121	CB6811
R535	311-1230-00			RES., VAR, NONWIR:20K OHM, 20%, 0.50W	32997	3386F-T04-203
R536	315-0202-00			RES., FXD, CMPSN:2K OHM, 5%, 0.25W	01121	CB2025
R537	315-0560-00			RES., FXD, CMPSN:56 OHM, 5%, 0.25W	01121	CB5605
R538	315-0362-00			RES., FXD, CMPSN:3.6K OHM, 5%, 0.25W	01121	CB3625
R539	316-0222-00			RES., FXD, CMPSN:2.2K OHM, 10%, 0.25W	01121	CB2221
R540	315-0222-00	B250000	B279999	RES., FXD, CMPSN:2.2K OHM, 5%, 0.25W	01121	CB2225
R540	315-0182-00	B280000		RES., FXD, CMPSN:1.8K OHM, 5%, 0.25W	01121	CB1825

¹Furnished as a unit with S530.

Replaceable Electrical Parts—465 Service (SN B25000-up)

Ckt No.	Tektronix Part No.	Serial/Model No. Eff	Dscont	Name & Description	Mfr Code	Mfr Part Number
R541	316-0682-00			RES.,FXD,CMPSN:6.8K OHM,10%,0.25W	01121	CB6821
R542	316-0182-00			RES.,FXD,CMPSN:1.8K OHM,10%,0.25W	01121	CB1821
R544	316-0103-00			RES.,FXD,CMPSN:10K OHM,10%,0.25W	01121	CB1031
R545	311-1230-00			RES.,VAR,NONWIR:20K OHM,20%,0.50W	32997	3386F-T04-203
R546	315-0101-00			RES.,FXD,CMPSN:100 OHM,5%,0.25W	01121	CB1015
R547	315-0101-00			RES.,FXD,CMPSN:100 OHM,5%,0.25W	01121	CB1015
R549	315-0331-00			RES.,FXD,CMPSN:330 OHM,5%,0.25W	01121	CB3315
R550	316-0330-00			RES.,FXD,CMPSN:33 OHM,10%,0.25W	01121	CB3301
R551	323-0305-00			RES.,FXD,FILM:14.7K OHM,1%,0.50W	75042	CECT0-1472F
R552	316-0330-00			RES.,FXD,CMPSN:33 OHM,10%,0.25W	01121	CB3301
R553	316-0153-00			RES.,FXD,CMPSN:15K OHM,10%,0.25W	01121	CB1531
R554	316-0104-00			RES.,FXD,CMPSN:100K OHM,10%,0.25W	01121	CB1041
R555	311-1230-00			RES.,VAR,NONWIR:20K OHM,20%,0.50W	32997	3386F-T04-203
R556	316-0562-00			RES.,FXD,CMPSN:5.6K OHM,10%,0.25W	01121	CB5621
R557	321-0097-00			RES.,FXD,FILM:100 OHM,1%,0.125W	91637	MFF1816G100R0F
R558	321-0258-00			RES.,FXD,FILM:4.75K OHM,1%,0.125W	91637	MFF1816G47500F
R602	316-0470-00			RES.,FXD,CMPSN:47 OHM,10%,0.25W	01121	CB4701
R603	325-0073-00			RES.,FXD,FILM:3.57M OHM,1%,0.50W	03888	PME70-G35703F
R604	321-0385-00			RES.,FXD,FILM:100K OHM,1%,0.125W	91637	MFF1816G10002F
R606	323-0480-00			RES.,FXD,FILM:976K OHM,1%,0.50W	91637	MFF1226G97602F
R607	321-0451-00			RES.,FXD,FILM:487K OHM,1%,0.125W	91637	MFF1816G48702F
R608	315-0200-00			RES.,FXD,CMPSN:20 OHM,5%,0.25W	01121	CB2005
R609	316-0274-00			RES.,FXD,CMPSN:270K OHM,10%,0.25W	01121	CB2741
R611	316-0104-00			RES.,FXD,CMPSN:100K OHM,10%,0.25W	01121	CB1041
R612	316-0563-00			RES.,FXD,CMPSN:56K OHM,10%,0.25W	01121	CB5631
R616	321-0481-00			RES.,FXD,FILM:1M OHM,1%,0.125W	91637	MFF1816G10003F
R617	316-0101-00			RES.,FXD,CMPSN:100 OHM,10%,0.25W	01121	CB1011
R618	316-0101-00			RES.,FXD,CMPSN:100 OHM,10%,0.25W	01121	CB1011
R622	316-0101-00			RES.,FXD,CMPSN:100 OHM,10%,0.25W	01121	CB1011
R623	316-0150-00			RES.,FXD,CMPSN:15 OHM,10%,0.25W	01121	CB1501
R624	316-0150-00			RES.,FXD,CMPSN:15 OHM,10%,0.25W	01121	CB1501
R625	316-0101-00			RES.,FXD,CMPSN:100 OHM,10%,0.25W	01121	CB1011
R626	317-0102-00	XB298265		RES.,FXD,CMPSN:1K OHM,5%,0.125W	01121	BB1025
R627	321-0209-00			RES.,FXD,FILM:1.47K OHM,1%,0.125W	91637	MFF1816G14700F
R628	315-0390-00			RES.,FXD,CMPSN:39 OHM,5%,0.25W	01121	CB3905
R629	321-0209-00			RES.,FXD,FILM:1.47K OHM,1%,0.125W	91637	MFF1816G14700F
R630 ¹	311-1192-00			RES.,VAR,NONWIR:10K OHM,20%,1W	71590	BR-232-001
R631	316-0681-00			RES.,FXD,CMPSN:680 OHM,10%,0.25W	01121	CB6811
R635	311-1230-00			RES.,VAR,NONWIR:20K OHM,20%,0.50W	32997	3386F-T04-203
R636	315-0202-00			RES.,FXD,CMPSN:2K OHM,5%,0.25W	01121	CB2025
R637	315-0560-00			RES.,FXD,CMPSN:56 OHM,5%,0.25W	01121	CB5605
R638	315-0362-00			RES.,FXD,CMPSN:3.6K OHM,5%,0.25W	01121	CB3625
R639	316-0222-00			RES.,FXD,CMPSN:2.2K OHM,10%,0.25W	01121	CB2221
R640	315-0222-00	B250000	B279999	RES.,FXD,CMPSN:2.2K OHM,5%,0.25W	01121	CB2225
R640	315-0182-00	B280000		RES.,FXD,CMPSN:1.8K OHM,5%,0.25W	01121	CB1825
R641	316-0682-00			RES.,FXD,CMPSN:6.8K OHM,10%,0.25W	01121	CB6821
R642	316-0182-00			RES.,FXD,CMPSN:1.8K OHM,10%,0.25W	01121	CB1821
R644	316-0103-00			RES.,FXD,CMPSN:10K OHM,10%,0.25W	01121	CB1031
R645	311-1230-00			RES.,VAR,NONWIR:20K OHM,20%,0.50W	32997	3386F-T04-203
R646	315-0101-00			RES.,FXD,CMPSN:100 OHM,5%,0.25W	01121	CB1015
R647	315-0101-00			RES.,FXD,CMPSN:100 OHM,5%,0.25W	01121	CB1015
R649	315-0331-00			RES.,FXD,CMPSN:330 OHM,5%,0.25W	01121	CB3315
R650	316-0330-00			RES.,FXD,CMPSN:33 OHM,10%,0.25W	01121	CB3301

¹Furnished as a unit with S630.

Replaceable Electrical Parts—465 Service (SN B25000-up)

Ckt No.	Tektronix Part No.	Serial/Model No. Eff	Dscont	Name & Description	Mfr Code	Mfr Part Number
R651	323-0305-00			RES.,FXD,FILM:14.7K OHM,1%,0.50W	75042	CECT0-1472F
R652	316-0330-00			RES.,FXD,CMPSN:33 OHM,10%,0.25W	01121	CB3301
R655	311-1230-00			RES.,VAR,NONWIR:20K OHM,20%,0.50W	32997	3386F-T04-203
R656	316-0562-00			RES.,FXD,CMPSN:5.6K OHM,10%,0.25W	01121	CB5621
R657	321-0097-00			RES.,FXD,FILM:100 OHM,1%,0.125W	91637	MFF1816G100R0F
R658	321-0258-00			RES.,FXD,FILM:4.75K OHM,1%,0.125W	91637	MFF1816G47500F
R671	316-0100-00			RES.,FXD,CMPSN:10 OHM,10%,0.25W	01121	CB1001
R672	315-0680-00			RES.,FXD,CMPSN:68 OHM,5%,0.25W	01121	CB6805
R675	311-1259-00			RES.,VAR,NONWIR:100 OHM,10%,0.50W	32997	3329P-L58-101
R676	315-0510-00			RES.,FXD,CMPSN:51 OHM,5%,0.25W	01121	CB5105
R677	315-0102-00			RES.,FXD,CMPSN:1K OHM,5%,0.25W	01121	CB1025
R678	315-0510-00			RES.,FXD,CMPSN:51 OHM,5%,0.25W	01121	CB5105
R679	315-0120-00			RES.,FXD,CMPSN:12 OHM,5%,0.25W	01121	CB1205
R681	316-0100-00			RES.,FXD,CMPSN:10 OHM,10%,0.25W	01121	CB1001
R682	315-0680-00			RES.,FXD,CMPSN:68 OHM,5%,0.25W	01121	CB6805
R683	315-0471-00			RES.,FXD,CMPSN:470 OHM,5%,0.25W	01121	CB4715
R687	315-0102-00			RES.,FXD,CMPSN:1K OHM,5%,0.25W	01121	CB1025
R688	315-0510-00			RES.,FXD,CMPSN:51 OHM,5%,0.25W	01121	CB5105
R689	315-0120-00			RES.,FXD,CMPSN:12 OHM,5%,0.25W	01121	CB1205
R690	316-0100-00			RES.,FXD,CMPSN:10 OHM,10%,0.25W	01121	CB1001
R691	316-0104-00			RES.,FXD,CMPSN:100K OHM,10%,0.25W	01121	CB1041
R692	315-0152-00			RES.,FXD,CMPSN:1.5K OHM,5%,0.25W	01121	CB1525
R694	315-0431-00			RES.,FXD,CMPSN:430 OHM,5%,0.25W	01121	CB4315
R803	315-0391-00			RES.,FXD,CMPSN:390 OHM,5%,0.25W	01121	CB3915
R804	321-0186-00			RES.,FXD,FILM:845 OHM,1%,0.125W	91637	MFF1816G845R0F
R805	316-0220-00			RES.,FXD,CMPSN:22 OHM,10%,0.25W	01121	CB2201
R807	321-0243-00			RES.,FXD,FILM:3.32K OHM,1%,0.125W	91637	MFF1816G33200F
R808	321-0206-00			RES.,FXD,FILM:1.37K OHM,1%,0.125W	91637	MFF1816G13700F
R809	315-0132-00			RES.,FXD,CMPSN:1.3K OHM,5%,0.25W	01121	CB1325
R811	315-0390-00			RES.,FXD,CMPSN:39 OHM,5%,0.25W	01121	CB3905
R812	321-0211-00			RES.,FXD,FILM:1.54K OHM,1%,0.125W	91637	MFF1816G15400F
R814	315-0332-00			RES.,FXD,CMPSN:3.3K OHM,5%,0.25W	01121	CB3325
R815	315-0151-00			RES.,FXD,CMPSN:150 OHM,5%,0.25W	01121	CB1515
R817	315-0681-00			RES.,FXD,CMPSN:680 OHM,5%,0.25W	01121	CB6815
R818	315-0681-00			RES.,FXD,CMPSN:680 OHM,5%,0.25W	01121	CB6815
R822	315-0103-00			RES.,FXD,CMPSN:10K OHM,5%,0.25W	01121	CB1035
R823	315-0153-00			RES.,FXD,CMPSN:15K OHM,5%,0.25W	01121	CB1535
R824	315-0103-00			RES.,FXD,CMPSN:10K OHM,5%,0.25W	01121	CB1035
R827	315-0102-00			RES.,FXD,CMPSN:1K OHM,5%,0.25W	01121	CB1025
R828	315-0102-00			RES.,FXD,CMPSN:1K OHM,5%,0.25W	01121	CB1025
R829	316-0220-00			RES.,FXD,CMPSN:22 OHM,10%,0.25W	01121	CB2201
R831	315-0102-00			RES.,FXD,CMPSN:1K OHM,5%,0.25W	01121	CB1025
R834	315-0100-00			RES.,FXD,CMPSN:10 OHM,5%,0.25W	01121	CB1005
R836	315-0100-00			RES.,FXD,CMPSN:10 OHM,5%,0.25W	01121	CB1005
R838	316-0101-00			RES.,FXD,CMPSN:100 OHM,10%,0.25W	01121	CB1011
R853	315-0471-00			RES.,FXD,CMPSN:470 OHM,5%,0.25W	01121	CB4715
R854	321-0200-00			RES.,FXD,FILM:1.18K OHM,1%,0.125W	91637	MFF1816G11800F
R855	316-0220-00			RES.,FXD,CMPSN:22 OHM,10%,0.25W	01121	CB2201
R856	316-0270-00			RES.,FXD,CMPSN:27 OHM,10%,0.25W	01121	CB2701
R857	321-0243-00			RES.,FXD,FILM:3.32K OHM,1%,0.125W	91637	MFF1816G33200F
R858	321-0201-00			RES.,FXD,FILM:1.21K OHM,1%,0.125W	91637	MFF1816G12100F
R859	315-0132-00			RES.,FXD,CMPSN:1.3K OHM,5%,0.25W	01121	CB1325
R861	315-0390-00			RES.,FXD,CMPSN:39 OHM,5%,0.25W	01121	CB3905

Replaceable Electrical Parts—465 Service (SN B250000-up)

Ckt No.	Tektronix Part No.	Serial/Model No. Eff	Dscont	Name & Description	Mfr Code	Mfr Part Number
R862	321-0209-00			RES.,FXD,FILM:1.47K OHM,1%,0.125W	91637	MFF1816G14700F
R863	315-0103-00			RES.,FXD,CMPSN:10K OHM,5%,0.25W	01121	CB1035
R864	315-0332-00			RES.,FXD,CMPSN:3.3K OHM,5%,0.25W	01121	CB3325
R865	315-0151-00			RES.,FXD,CMPSN:150 OHM,5%,0.25W	01121	CB1515
R866	315-0471-00			RES.,FXD,CMPSN:470 OHM,5%,0.25W	01121	CB4715
R871	315-0472-00			RES.,FXD,CMPSN:4.7K OHM,5%,0.25W	01121	CB4725
R872	315-0241-00			RES.,FXD,CMPSN:240 OHM,5%,0.25W	01121	CB2415
R877	315-0102-00			RES.,FXD,CMPSN:1K OHM,5%,0.25W	01121	CB1025
R879	315-0274-00	B250000	B279999	RES.,FXD,CMPSN:270K OHM,5%,0.25W	01121	CB2745
R879	315-0334-00	B280000		RES.,FXD,CMPSN:330K OHM,5%,0.25W	01121	CB3345
R1001	315-0360-00			RES.,FXD,CMPSN:36 OHM,5%,0.25W	01121	CB3605
R1002	303-0432-00			RES.,FXD,CMPSN:4.3K OHM,5%,1W	01121	GB4325
R1003	316-0101-00			RES.,FXD,CMPSN:100 OHM,10%,0.25W	01121	CB1011
R1004	315-0360-00			RES.,FXD,CMPSN:36 OHM,5%,0.25W	01121	CB3605
R1006	308-0421-00			RES.,FXD,WW:3K OHM,5%,3W	91637	CW-2B B30000J
R1007	315-0271-00			RES.,FXD,CMPSN:270 OHM,5%,0.25W	01121	CB2715
R1011	316-0103-00			RES.,FXD,CMPSN:10K OHM,10%,0.25W	01121	CB1031
R1012	321-0164-00			RES.,FXD,FILM:499 OHM,1%,0.125W	91637	MFF1816G499ROF
R1013	321-0228-00			RES.,FXD,FILM:2.32K OHM,1%,0.125W	91637	MFF1816G23200F
R1016	321-0195-00			RES.,FXD,FILM:1.05K OHM,1%,0.125W	91637	MFF1816G10500F
R1017	321-0250-00			RES.,FXD,FILM:3.92K OHM,1%,0.125W	91637	MFF1816G39200F
R1021	321-0193-00			RES.,FXD,FILM:1K OHM,1%,0.125W	91637	MFF1816G10000F
R1022	321-0193-00			RES.,FXD,FILM:1K OHM,1%,0.125W	91637	MFF1816G10000F
R1024	321-0165-00			RES.,FXD,FILM:511 OHM,1%,0.125W	91637	MFF1816G511ROF
R1026	316-0181-00			RES.,FXD,CMPSN:180 OHM,10%,0.25W	01121	CB1811
R1029	316-0101-00			RES.,FXD,CMPSN:100 OHM,10%,0.25W	01121	CB1011
R1031	316-0470-00			RES.,FXD,CMPSN:47 OHM,10%,0.25W	01121	CB4701
R1032	316-0101-00			RES.,FXD,CMPSN:100 OHM,10%,0.25W	01121	CB1011
R1033	321-0256-00			RES.,FXD,FILM:4.53K OHM,1%,0.125W	91637	MFF1816G45300F
R1035	316-0101-00			RES.,FXD,CMPSN:100 OHM,10%,0.25W	01121	CB1011
R1037	321-0251-01			RES.,FXD,FILM:4.02K OHM,0.5%,0.125W	91637	MFF1816G40200D
R1038	316-0470-00			RES.,FXD,CMPSN:47 OHM,10%,0.25W	01121	CB4701
R1039	321-0228-00			RES.,FXD,FILM:2.32K OHM,1%,0.125W	91637	MFF1816G23200F
R1041	316-0101-00			RES.,FXD,CMPSN:100 OHM,10%,0.25W	01121	CB1011
R1044	321-0227-00			RES.,FXD,FILM:2.26K OHM,1%,0.125W	91637	MFF1816G22600F
R1045	316-0101-00			RES.,FXD,CMPSN:100 OHM,10%,0.25W	01121	CB1011
R1046	301-0562-00			RES.,FXD,CMPSN:5.6K OHM,5%,0.50W	01121	EB5625
R1047	315-0681-00			RES.,FXD,CMPSN:680 OHM,5%,0.25W	01121	CB6815
R1048	315-0752-00			RES.,FXD,CMPSN:7.5K OHM,5%,0.25W	01121	CB7525
R1049	315-0681-00			RES.,FXD,CMPSN:680 OHM,5%,0.25W	01121	CB6815
R1052	315-0561-00			RES.,FXD,CMPSN:560 OHM,5%,0.25W	01121	CB5615
R1053	301-0622-00			RES.,FXD,CMPSN:6.2K OHM,5%,0.50W	01121	EB6225
R1054	315-0102-00			RES.,FXD,CMPSN:1K OHM,5%,0.25W	01121	CB1025
R1057	315-0562-00			RES.,FXD,CMPSN:5.6K OHM,5%,0.25W	01121	CB5625
R1061	315-0360-00			RES.,FXD,CMPSN:36 OHM,5%,0.25W	01121	CB3605
R1062	301-0432-00			RES.,FXD,CMPSN:4.3K OHM,5%,0.50W	01121	EB4325
R1063	316-0101-00			RES.,FXD,CMPSN:100 OHM,10%,0.25W	01121	CB1011
R1064	315-0360-00			RES.,FXD,CMPSN:36 OHM,5%,0.25W	01121	CB3605
R1065	316-0220-00			RES.,FXD,CMPSN:22 OHM,10%,0.25W	01121	CB2201
R1066	308-0421-00			RES.,FXD,WW:3K OHM,5%,3W	91637	CW-2B B30000J
R1071	316-0103-00			RES.,FXD,CMPSN:10K OHM,10%,0.25W	01121	CB1031
R1072	321-0164-00			RES.,FXD,FILM:499 OHM,1%,0.125W	91637	MFF1816G499ROF
R1073	321-0228-00			RES.,FXD,FILM:2.32K OHM,1%,0.125W	91637	MFF1816G23200F

Replaceable Electrical Parts—465 Service (SN B25000-up)

Ckt No.	Tektronix Part No.	Serial/Model No. Eff	Discont	Name & Description	Mfr Code	Mfr Part Number
R1076	321-0195-00			RES.,FXD,FILM:1.05K OHM,1%,0.125W	91637	MFF1816G10500F
R1077	321-0250-00			RES.,FXD,FILM:3.92K OHM,1%,0.125W	91637	MFF1816G39200F
R1081	321-0193-00			RES.,FXD,FILM:1K OHM,1%,0.125W	91637	MFF1816G10000F
R1082	321-0193-00			RES.,FXD,FILM:1K OHM,1%,0.125W	91637	MFF1816G10000F
R1084	321-0165-00			RES.,FXD,FILM:511 OHM,1%,0.125W	91637	MFF1816G511ROF
R1086	316-0181-00			RES.,FXD,CMPSN:180 OHM,10%,0.25W	01121	CB1811
R1089	316-0101-00			RES.,FXD,CMPSN:100 OHM,10%,0.25W	01121	CB1011
R1091	316-0470-00			RES.,FXD,CMPSN:47 OHM,10%,0.25W	01121	CB4701
R1092	316-0101-00			RES.,FXD,CMPSN:100 OHM,10%,0.25W	01121	CB1011
R1093	321-0256-00			RES.,FXD,FILM:4.53K OHM,1%,0.125W	91637	MFF1816G45300F
R1095	316-0101-00			RES.,FXD,CMPSN:100 OHM,10%,0.25W	01121	CB1011
R1097	321-0251-01			RES.,FXD,FILM:4.02K OHM,0.5%,0.125W	91637	MFF1816G40200D
R1098	321-0229-00			RES.,FXD,FILM:2.37K OHM,1%,0.125W	91637	MFF1816G23700F
R1101	315-0682-00			RES.,FXD,CMPSN:6.8K OHM,5%,0.25W	01121	CB6825
R1110	311-1464-00			RES.,VAR,WW:2K OHM,5%,2W	02111	534-264
R1110 ¹	311-1709-00			RES.,VAR,WW:20K OHM,10%,2W	73138	8136-22-0
R1111	321-0169-00			RES.,FXD,FILM:562 OHM,1%,0.125W	91637	MFF1816G562ROF
R1111 ¹	321-0265-00			RES.,FXD,FILM:5.62K OHM,1%,0.125W	91637	MFF1816G56200F
R1112	321-0068-00			RES.,FXD,FILM:49.9 OHM,1%,0.125W	91637	MFF1816G49R90F
R1112 ¹	321-0252-00			RES.,FXD,FILM:4.12K OHM,1%,0.125W	91637	MFF1816G41200F
R1113	321-0125-00			RES.,FXD,FILM:196 OHM,1%,0.125W	91637	MFF1816G196ROF
R1113 ¹	321-0154-00			RES.,FXD,FILM:392 OHM,1%,0.125W	91637	MFF1816G392ROF
R1115	311-1244-00			RES.,VAR,NONWIR:100 OHM,10%,0.50W	32997	3386X-T07-101
R1117	321-0231-00			RES.,FXD,FILM:2.49K OHM,1%,0.125W	91637	MFF1816G24900F
R1130	315-0101-00			RES.,FXD,CMPSN:100 OHM,5%,0.25W	01121	CB1015
R1131	323-0498-04			RES.,FXD,FILM:1.5M OHM,0.1%,0.50W	91637	HFF129D15003B
R1133	323-0481-04			RES.,FXD,FILM:1M OHM,0.1%,0.50W	91637	MFF1226D10003B
R1134	321-0648-04			RES.,FXD,FILM:500K OHM,0.1%,0.125W	91637	HMF188D50002B
R1135	321-0618-04			RES.,FXD,FILM:250K OHM,0.1%,0.125W	91637	MFF1816D25002B
R1136	321-0414-04			RES.,FXD,FILM:200K OHM,0.1%,0.125W	91637	MFF1816D20002B
R1137	321-0385-04			RES.,FXD,FILM:100K OHM,0.1%,0.125W	91637	MFF1816D10002B
R1138	321-0756-04			RES.,FXD,FILM:50K OHM,0.1%,0.125W	91637	MFF1816D50001B
R1140 ²	311-1701-00			RES.,VAR,NONWIR:50K OHM,20%,1W	01121	12M572
R1141	315-0154-00			RES.,FXD,CMPSN:150K OHM,5%,0.25W	01121	CB1545
R1142 ³	321-0222-07			RES.,FXD,FILM:2K OHM,0.1%,0.125W	91637	MFF1816C20000B
R1143 ³	321-0193-07			RES.,FXD,FILM:1K OHM,0.1%,0.125W	91637	MFF1816C10000B
R1144 ³	321-0193-07			RES.,FXD,FILM:1K OHM,0.1%,0.125W	91637	MFF1816C10000B
R1145	311-1245-00			RES.,VAR,NONWIR:10K OHM,10%,0.50W	73138	72X-28-0-103K
R1146	315-0472-00			RES.,FXD,CMPSN:4.7K OHM,5%,0.25W	01121	CB4725
R1151	321-0429-00			RES.,FXD,FILM:287K OHM,1%,0.125W	91637	MFF1816G28702F
R1153	321-0338-00			RES.,FXD,FILM:32.4K OHM,1%,0.125W	91637	MFF1816G32401F
R1155 ⁴	311-1410-00			RES.,VAR,NONWIR:25K OHM,20%,1W	01121	10M923
R1161	323-0498-04			RES.,FXD,FILM:1.5M OHM,0.1%,0.50W	91637	HFF129D15003B
R1163	323-0481-04			RES.,FXD,FILM:1M OHM,0.1%,0.50W	91637	MFF1226D10003B
R1164	321-0648-04			RES.,FXD,FILM:500K OHM,0.1%,0.125W	91637	HMF188D50002B
R1165	321-0618-04			RES.,FXD,FILM:250K OHM,0.1%,0.125W	91637	MFF1816D25002B
R1166	321-0414-04			RES.,FXD,FILM:200K OHM,0.1%,0.125W	91637	MFF1816D20002B
R1167	321-0385-04			RES.,FXD,FILM:100K OHM,0.1%,0.125W	91637	MFF1816D10002B
R1168	321-0756-04			RES.,FXD,FILM:50K OHM,0.1%,0.125W	91637	MFF1816D50001B
R1170	315-0473-00			RES.,FXD,CMPSN:47K OHM,5%,0.25W	01121	CB4735
R1175	311-1245-00			RES.,VAR,NONWIR:10K OHM,10%,0.50W	73138	72X-28-0-103K
R1201	316-0471-00			RES.,FXD,CMPSN:470 OHM,10%,0.25W	01121	CB4711
R1202	321-0212-00			RES.,FXD,FILM:1.58K OHM,1%,0.125W	91637	MFF1816G15800F

¹See DM manual for alternate version.

²Furnished as a unit with S1140.

³Refer to DM manuals.

⁴Furnished as a unit with S1155A,B.

Replaceable Electrical Parts—465 Service (SN B25000-up)

Ckt No.	Tektronix Part No.	Serial/Model No. Eff	Dscont	Name & Description	Mfr Code	Mfr Part Number
R1205A,B	311-1430-00			RES.,VAR, NONWIR:5K OHM X 50K OHM,20%,0.50W	01121	10M957
R1206	315-0202-00			RES.,FXD,CMPSN:2K OHM,5%,0.25W	01121	CB2025
R1207	315-0203-00			RES.,FXD,CMPSN:20K OHM,5%,0.25W	01121	CB2035
R1208	315-0432-00			RES.,FXD,CMPSN:4.3K OHM,5%,0.25W	01121	CB4325
R1209	315-0433-00			RES.,FXD,CMPSN:43K OHM,5%,0.25W	01121	CB4335
R1211	321-0130-00			RES.,FXD,FILM:221 OHM,1%,0.125W	91637	MFF1816G221ROF
R1212	316-0102-00			RES.,FXD,CMPSN:1K OHM,10%,0.25W	01121	CB1021
R1214	321-0174-00			RES.,FXD,FILM:634 OHM,1%,0.125W	91637	MFF1816G634ROF
R1215	311-1222-00			RES.,VAR, NONWIR:100 OHM,20%,0.50W	32997	3386F-T04-101
R1216	321-0264-00			RES.,FXD,FILM:5.49K OHM,1%,0.125W	91637	MFF1816G54900F
R1217	321-0147-00			RES.,FXD,FILM:332 OHM,1%,0.125W	91637	MFF1816G332ROF
R1218	315-0152-00			RES.,FXD,CMPSN:1.5K OHM,5%,0.25W	01121	CB1525
R1219	321-0164-00			RES.,FXD,FILM:499 OHM,1%,0.125W	91637	MFF1816G499ROF
R1220	321-0034-00			RES.,FXD,FILM:22.1 OHM,1%,0.125W	91637	MFF1816G22R10F
R1221	321-0173-00			RES.,FXD,FILM:619 OHM,1%,0.125W	91637	MFF1816G619ROF
R1222	321-0173-00			RES.,FXD,FILM:619 OHM,1%,0.125W	91637	MFF1816G619ROF
R1223	321-0184-00			RES.,FXD,FILM:806 OHM,1%,0.125W	91637	MFF1816G806ROF
R1224	323-0248-00			RES.,FXD,FILM:3.74K OHM,1%,0.50W	75042	CECTO-3741F
R1225	311-1226-00			RES.,VAR, NONWIR:2.5K OHM,20%,0.50W	32997	3386F-T04-252
R1226	323-0296-00			RES.,FXD,FILM:11.8K OHM,1%,0.50W	75042	CECTO-1182F
R1228	321-0210-00			RES.,FXD,FILM:1.5K OHM,1%,0.125W	91637	MFF1816G15000F
R1229	316-0154-00			RES.,FXD,CMPSN:150K OHM,10%,0.25W	01121	CB1541
R1231	321-0222-00			RES.,FXD,FILM:2K OHM,1%,0.125W	91637	MFF1816G20000F
R1232	315-0270-00			RES.,FXD,CMPSN:27 OHM,5%,0.25W	01121	CB2705
R1233	321-0184-00			RES.,FXD,FILM:806 OHM,1%,0.125W	91637	MFF1816G806ROF
R1234	323-0248-00			RES.,FXD,FILM:3.74K OHM,1%,0.50W	75042	CECTO-3741F
R1235	323-0191-00			RES.,FXD,FILM:953 OHM,1%,0.50W	75042	CECTO-9530F
R1236	323-0296-00			RES.,FXD,FILM:11.8K OHM,1%,0.50W	75042	CECTO-1182F
R1237	311-1225-00			RES.,VAR, NONWIR:1K OHM,20%,0.50W	32997	3386F-T04-102
R1238	311-1222-00			RES.,VAR, NONWIR:100 OHM,20%,0.50W	32997	3386F-T04-101
R1239	321-0110-00			RES.,FXD,FILM:137 OHM,1%,0.125W	91637	MFF1816G137ROF
R1241	321-0168-00			RES.,FXD,FILM:549 OHM,1%,0.125W	91637	MFF1816G549ROF
R1242	321-0168-00			RES.,FXD,FILM:549 OHM,1%,0.125W	91637	MFF1816G549ROF
R1244	321-0122-00			RES.,FXD,FILM:182 OHM,1%,0.125W	91637	MFF1816G182ROF
R1246	321-0260-00			RES.,FXD,FILM:4.99K OHM,1%,0.125W	91637	MFF1816G49900F
R1247	315-0201-00			RES.,FXD,CMPSN:200 OHM,5%,0.25W	01121	CB2015
R1248	321-0228-00			RES.,FXD,FILM:2.32K OHM,1%,0.125W	91637	MFF1816G23200F
R1249	315-0182-00			RES.,FXD,CMPSN:1.8K OHM,5%,0.25W	01121	CB1825
R1253	321-0299-00			RES.,FXD,FILM:12.7K OHM,1%,0.125W	91637	MFF1816G12701F
R1254	321-0140-00			RES.,FXD,FILM:280 OHM,1%,0.125W	91637	MFF1816G280ROF
R1255	302-0181-00			RES.,FXD,CMPSN:180 OHM,10%,0.50W	01121	EB1811
R1260	322-0289-00			RES.,FXD,FILM:10K OHM,1%,0.25W	75042	CEBT0-1002F
R1261	322-0289-00			RES.,FXD,FILM:10K OHM,1%,0.25W	75042	CEBT0-1002F
R1262	321-0189-00			RES.,FXD,FILM:909 OHM,1%,0.125W	91637	MFF1816G909ROF
R1263	316-0470-00			RES.,FXD,CMPSN:47 OHM,10%,0.25W	01121	CB4701
R1264	302-0393-00			RES.,FXD,CMPSN:39K OHM,10%,0.50W	01121	EB3931
R1266	316-0101-00			RES.,FXD,CMPSN:100 OHM,10%,0.25W	01121	CB1011
R1268	321-0222-00			RES.,FXD,FILM:2K OHM,1%,0.125W	91637	MFF1816G20000F
R1269	321-0268-00			RES.,FXD,FILM:6.04K OHM,1%,0.125W	91637	MFF1816G60400F
R1273	321-0299-00			RES.,FXD,FILM:12.7K OHM,1%,0.125W	91637	MFF1816G12701F
R1274	323-0177-00			RES.,FXD,FILM:680 OHM,1%,0.50W	91637	MFF1226G681ROF
R1275	302-0221-00			RES.,FXD,CMPSN:220 OHM,10%,0.50W	01121	EB2211
R1280	322-0289-00			RES.,FXD,FILM:10K OHM,1%,0.25W	75042	CEBT0-1002F

Replaceable Electrical Parts—465 Service (SN B25000-up)

Ckt No.	Tektronix Part No.	Serial/Model No. Eff	Dscont	Name & Description	Mfr Code	Mfr Part Number
R1281	322-0289-00			RES.,FXD,FILM:10K OHM,1%,0.25W	75042	CEBT0-1002F
R1282	321-0189-00			RES.,FXD,FILM:909 OHM,1%,0.125W	91637	MFF1816G909ROF
R1283	316-0470-00			RES.,FXD,CMPSN:47 OHM,10%,0.25W	01121	CB4701
R1284	302-0393-00			RES.,FXD,CMPSN:39K OHM,10%,0.50W	01121	EB3931
R1286	316-0101-00			RES.,FXD,CMPSN:100 OHM,10%,0.25W	01121	CB1011
R1288	316-0470-00			RES.,FXD,CMPSN:47 OHM,10%,0.25W	01121	CB4701
R1289	302-0273-00			RES.,FXD,CMPSN:27K OHM,10%,0.50W	01121	EB2731
R1301	321-0160-00			RES.,FXD,FILM:453 OHM,1%,0.125W	91637	MFF1816G453ROF
R1302	321-0160-00			RES.,FXD,FILM:453 OHM,1%,0.125W	91637	MFF1816G453ROF
R1303	321-0209-00			RES.,FXD,FILM:1.47K OHM,1%,0.125W	91637	MFF1816G14700F
R1304	315-0472-00			RES.,FXD,CMPSN:4.7K OHM,5%,0.25W	01121	CB4725
R1306	315-0112-00			RES.,FXD,CMPSN:1.1K OHM,5%,0.25W	01121	CB1125
R1307	321-0192-00			RES.,FXD,FILM:976 OHM,1%,0.125W	91637	MFF1816G976ROF
R1308	321-0171-00			RES.,FXD,FILM:590 OHM,1%,0.125W	91637	MFF1816G590ROF
R1314	315-0911-00			RES.,FXD,CMPSN:910 OHM,5%,0.25W	01121	CB9115
R1315	315-0221-00			RES.,FXD,CMPSN:220 OHM,5%,0.25W	01121	CB2215
R1317	301-0471-00			RES.,FXD,CMPSN:470 OHM,5%,0.50W	01121	EB4715
R1318 ¹						
R1321	321-0160-00			RES.,FXD,FILM:453 OHM,1%,0.125W	91637	MFF1816G453ROF
R1322	321-0160-00			RES.,FXD,FILM:453 OHM,1%,0.125W	91637	MFF1816G453ROF
R1323	321-0209-00			RES.,FXD,FILM:1.47K OHM,1%,0.125W	91637	MFF1816G14700F
R1324	315-0472-00			RES.,FXD,CMPSN:4.7K OHM,5%,0.25W	01121	CB4725
R1326	315-0112-00			RES.,FXD,CMPSN:1.1K OHM,5%,0.25W	01121	CB1125
R1327	321-0192-00			RES.,FXD,FILM:976 OHM,1%,0.125W	91637	MFF1816G976ROF
R1328	321-0171-00			RES.,FXD,FILM:590 OHM,1%,0.125W	91637	MFF1816G590ROF
R1334	315-0911-00			RES.,FXD,CMPSN:910 OHM,5%,0.25W	01121	CB9115
R1335	315-0221-00			RES.,FXD,CMPSN:220 OHM,5%,0.25W	01121	CB2215
R1337	301-0471-00			RES.,FXD,CMPSN:470 OHM,5%,0.50W	01121	EB4715
R1339	316-0220-00			RES.,FXD,CMPSN:22 OHM,10%,0.25W	01121	CB2201
R1345	315-0202-00			RES.,FXD,CMPSN:2K OHM,5%,0.25W	01121	CB2025
R1348	316-0220-00			RES.,FXD,CMPSN:22 OHM,10%,0.25W	01121	CB2201
R1349	316-0220-00			RES.,FXD,CMPSN:22 OHM,10%,0.25W	01121	CB2201
R1400	311-1228-00			RES.,VAR,NONWIR:10K OHM,20%,0.50W	32997	3386F-T04-103
R1401	322-0464-00			RES.,FXD,FILM:665K OHM,1%,0.25W	75042	CEBT0-6653F
R1402	316-0224-00			RES.,FXD,CMPSN:220K OHM,10%,0.25W	01121	CB2241
R1403	315-0273-00			RES.,FXD,CMPSN:27K OHM,5%,0.25W	01121	CB2735
R1404	315-0103-00			RES.,FXD,CMPSN:10K OHM,5%,0.25W	01121	CB1035
R1406	316-0683-00			RES.,FXD,CMPSN:68K OHM,10%,0.25W	01121	CB6831
R1407	316-0102-00			RES.,FXD,CMPSN:1K OHM,10%,0.25W	01121	CB1021
R1408	315-0242-00			RES.,FXD,CMPSN:2.4K OHM,5%,0.25W	01121	CB2425
R1409	316-0104-00			RES.,FXD,CMPSN:100K OHM,10%,0.25W	01121	CB1041
R1411	321-0327-00			RES.,FXD,FILM:24.9K OHM,1%,0.125W	91637	MFF1816G24901F
R1412	321-0329-00			RES.,FXD,FILM:26.1K OHM,1%,0.125W	91637	MFF1816G26101F
R1413	316-0103-00			RES.,FXD,CMPSN:10K OHM,10%,0.25W	01121	CB1031
R1414	316-0392-00			RES.,FXD,CMPSN:3.9K OHM,10%,0.25W	01121	CB3921
R1416	316-0472-00			RES.,FXD,CMPSN:4.7K OHM,10%,0.25W	01121	CB4721
R1420	315-0394-00			RES.,FXD,CMPSN:390K OHM,5%,0.25W	01121	CB3945
R1421	316-0103-00			RES.,FXD,CMPSN:10K OHM,10%,0.25W	01121	CB1031
R1422	316-0103-00			RES.,FXD,CMPSN:10K OHM,10%,0.25W	01121	CB1031
R1423	316-0103-00			RES.,FXD,CMPSN:10K OHM,10%,0.25W	01121	CB1031
R1427	316-0106-00			RES.,FXD,CMPSN:10M OHM,10%,0.25W	01121	CB1061
R1428	315-0182-00			RES.,FXD,CMPSN:1.8K OHM,5%,0.25W	01121	CB1825
R1430	311-0075-00			RES.,VAR,NONWIR:5M OHM,20%	12697	381-CM16993

¹See DM44 manual.

Replaceable Electrical Parts—465 Service (SN B250000-up)

Ckt No.	Tektronix Part No.	Serial/Model No. Eff Dscnt	Name & Description	Mfr Code	Mfr Part Number
R1431A	307-0290-04		RES.,FXD,FILM:6.57M OHM	80009	307-0290-04
R1431B			RES.,FXD,FILM:23.6M OHM		
R1431C			RES.,FXD,FILM:550K OHM		
R1431D			RES.,FXD,FILM:24.5M OHM		
R1434 ¹	311-1538-00		RES.,VAR,NONWIR:5K OHM X 2.5M OHM,10%	01121	11M518
R1440	311-1313-00		RES.,VAR,NONWIR:2K OHM,20%,1W	01121	73M4G048L202M
R1442	311-1235-00		RES.,VAR,NONWIR:100K OHM,20%,0.50W	32997	3386F-T04-104
R1445	311-1372-00		RES.,VAR,NONWIR:100K OHM,20%,1W	01121	10M835
R1446	311-1227-00		RES.,VAR,NONWIR:5K OHM,20%,0.50W	32997	3386F-T04-502
R1447	315-0223-00		RES.,FXD,CMPSN:22K OHM,5%,0.25W	01121	CB2235
R1448	315-0183-00		RES.,FXD,CMPSN:18K OHM,5%,0.25W	01121	CB1835
R1449	316-0101-00		RES.,FXD,CMPSN:100 OHM,10%,0.25W	01121	CB1011
R1451	301-0243-00		RES.,FXD,CMPSN:24K OHM,5%,0.50W	01121	EB2435
R1452	316-0221-00		RES.,FXD,CMPSN:22K OHM,10%,0.25W	01121	CB2211
R1453	316-0470-00		RES.,FXD,CMPSN:47 OHM,10%,0.25W	01121	CB4701
R1460 ¹	311-1538-00		RES.,VAR,NONWIR:5K OHM X 2.5M OHM,10%	01121	11M518
R1461	315-0302-00		RES.,FXD,CMPSN:3K OHM,5%,0.25W	01121	CB3025
R1462	315-0242-00		RES.,FXD,CMPSN:2.4K OHM,5%,0.25W	01121	CB2425
R1463	315-0122-00		RES.,FXD,CMPSN:1.2K OHM,5%,0.25W	01121	CB1225
R1464	315-0153-00		RES.,FXD,CMPSN:15K OHM,5%,0.25W	01121	CB1535
R1466	321-0220-00		RES.,FXD,FILM:1.91K OHM,1%,0.125W	91637	MFF1816G19100F
R1467	321-0168-00		RES.,FXD,FILM:549 OHM,1%,0.125W	91637	MFF1816G549R0F
R1468	321-0249-00		RES.,FXD,FILM:3.83K OHM,1%,0.125W	91637	MFF1816G38300F
R1469	323-0322-00		RES.,FXD,FILM:22.1K OHM,1%,0.50W	75042	CECT0-2212F
R1470	321-0307-00		RES.,FXD,FILM:15.4K OHM,1%,0.125W	91637	MFF1816G15401F
R1471	316-0101-00		RES.,FXD,CMPSN:100 OHM,10%,0.25W	01121	CB1011
R1472	316-0391-00		RES.,FXD,CMPSN:390 OHM,10%,0.25W	01121	CB3911
R1473	316-0102-00		RES.,FXD,CMPSN:1K OHM,10%,0.25W	01121	CB1021
R1474	316-0101-00		RES.,FXD,CMPSN:100 OHM,10%,0.25W	01121	CB1011
R1475	316-0102-00		RES.,FXD,CMPSN:1K OHM,10%,0.25W	01121	CB1021
R1476	315-0911-00		RES.,FXD,CMPSN:910 OHM,5%,0.25W	01121	CB9115
R1477	321-0201-00		RES.,FXD,FILM:1.21K OHM,1%,0.125W	91637	MFF1816G12100F
R1478	302-0393-00		RES.,FXD,CMPSN:39K OHM,10%,0.50W	01121	EB3931
R1480	311-1231-00		RES.,VAR,NONWIR:25K OHM,20%,0.50W	32997	3386F-T04-253
R1481	316-0103-00		RES.,FXD,CMPSN:10K OHM,10%,0.25W	01121	CB1031
R1482	316-0102-00		RES.,FXD,CMPSN:1K OHM,10%,0.25W	01121	CB1021
R1484	316-0471-00		RES.,FXD,CMPSN:470 OHM,10%,0.25W	01121	CB4711
R1485	316-0221-00		RES.,FXD,CMPSN:220 OHM,10%,0.25W	01121	CB2211
R1486	316-0226-00		RES.,FXD,CMPSN:22M OHM,10%,0.25W	01121	CB2261
R1488	316-0102-00		RES.,FXD,CMPSN:1K OHM,10%,0.25W	01121	CB1021
R1510	316-0103-00		RES.,FXD,CMPSN:10K OHM,10%,0.25W	01121	CB1031
R1511	316-0103-00		RES.,FXD,CMPSN:10K OHM,10%,0.25W	01121	CB1031
R1516	308-0363-00		RES.,FXD,WW:3K OHM,5%,8W	91637	RS8-B30000J
R1517	315-0200-00		RES.,FXD,CMPSN:20 OHM,5%,0.25W	01121	CB2005
R1518	303-0203-00		RES.,FXD,CMPSN:20K OHM,5%,1W	01121	GB2035
R1519	315-0101-00		RES.,FXD,CMPSN:100 OHM,5%,0.25W	01121	CB1015
R1521	323-0269-00		RES.,FXD,FILM:6.19K OHM,1%,0.50W	75042	CECT0-6191F
R1523	321-0292-00		RES.,FXD,FILM:10.7K OHM,1%,0.125W	91637	MFF1816G10701F
R1524	303-0472-00		RES.,FXD,CMPSN:4.7K OHM,5%,1W	01121	GB4725
R1525	316-0102-00		RES.,FXD,CMPSN:1K OHM,10%,0.25W	01121	CB1021
R1527	315-0183-00		RES.,FXD,CMPSN:18K OHM,5%,0.25W	01121	CB1835
R1528	303-0223-00		RES.,FXD,CMPSN:22K OHM,5%,1W	01121	GB2235
R1532	315-0122-00		RES.,FXD,CMPSN:1.2K OHM,5%,0.25W	01121	CB1225

¹R1434 and R1460 furnished as a unit.

Replaceable Electrical Parts—465 Service (SN B250000-up)

Ckt No.	Tektronix Part No.	Serial/Model No. Eff	Discont	Name & Description	Mfr Code	Mfr Part Number
R1533	315-0563-00			RES.,FXD,CMPSN:56K OHM,5%,0.25W	01121	CB5635
R1534	307-0052-00			RES.,FXD,CMPSN:3 OHM,5%,0.50W	01121	EB30G5
R1537	321-0366-00			RES.,FXD,FILM:63.4K OHM,1%,0.125W	91637	MFF1816G63401F
R1538	311-1226-00			RES.,VAR,NONWIR:2.5K OHM,20%,0.50W	32997	3386F-T04-252
R1539	321-0296-00			RES.,FXD,FILM:11.8K OHM,1%,0.125W	91637	MFF1816G11801F
R1543	321-0966-03			RES.,FXD,FILM:40K OHM,0.25%,0.125W	91637	MFF1816D40001C
R1544	321-0603-00			RES.,FXD,FILM:15K OHM,0.25%,0.125W	91637	MFF1816D15001C
R1546	315-0102-00			RES.,FXD,CMPSN:1K OHM,5%,0.25W	01121	CB1025
R1547	315-0153-00			RES.,FXD,CMPSN:15K OHM,5%,0.25W	01121	CB1535
R1549	308-0459-00			RES.,FXD,WW:1.1 OHM,5%,3W	91637	RS2B-D1R100J
R1553	321-0775-03			RES.,FXD,FILM:45K OHM,0.25%,0.125W	91637	MFF1816D45001C
R1554	321-0774-03			RES.,FXD,FILM:4.5K OHM,0.25%,0.125W	91637	MFF1816D45000C
R1556	315-0102-00			RES.,FXD,CMPSN:1K OHM,5%,0.25W	01121	CB1025
R1557	315-0512-00			RES.,FXD,CMPSN:5.1K OHM,5%,0.25W	01121	CB5125
R1559	307-0093-00			RES.,FXD,CMPSN:1.2 OHM,5%,0.50W	01121	EB12G5
R1563	321-0274-00			RES.,FXD,FILM:6.98K OHM,1%,0.125W	91637	MFF1816G69800F
R1564	321-0967-03			RES.,FXD,FILM:55K OHM,0.25%,0.125W	91637	MFF1816D55001C
R1565	321-0962-03			RES.,FXD,FILM:8K OHM,0.25%,0.125W	91637	MFF1816D80000C
R1566	315-0471-00			RES.,FXD,CMPSN:2.4K OHM,5%,0.25W	01121	CB4715
R1567	315-0242-00			RES.,FXD,CMPSN:2.4K OHM,5%,0.25W	01121	CB2425
R1569	308-0459-00			RES.,FXD,WW:1.1 OHM,5%,3W	91637	RS2B-D1R100J
R1570	311-1373-00			RES.,VAR,NONWIR:5K OHM,20%,1W	01121	16M188
R1571	315-0302-00			RES.,FXD,CMPSN:3K OHM,5%,0.25W	01121	CB3025
R1581	315-0153-00			RES.,FXD,CMPSN:15K OHM,5%,0.25W	01121	CB1535
R1584	321-0359-00			RES.,FXD,FILM:53.6K OHM,1%,0.125W	91637	MFF1816G53601F
R1585	321-0278-00			RES.,FXD,FILM:7.68K OHM,1%,0.125W	91637	MFF1816G76800F
R1586	316-0104-00			RES.,FXD,CMPSN:100K OHM,10%,0.25W	01121	CB1041
R1587	316-0104-00			RES.,FXD,CMPSN:100K OHM,10%,0.25W	01121	CB1041
R1589	315-0102-00			RES.,FXD,CMPSN:1K OHM,5%,0.25W	01121	CB1025
R1591	315-0912-00			RES.,FXD,CMPSN:9.1K OHM,5%,0.25W	01121	CB9125
R1592	315-0473-00			RES.,FXD,CMPSN:47K OHM,5%,0.25W	01121	CB4735
R1593	315-0822-00			RES.,FXD,CMPSN:8.2K OHM,5%,0.25W	01121	CB8225
R1594	315-0513-00			RES.,FXD,CMPSN:51K OHM,5%,0.25W	01121	CB5135
R1596	315-0512-00			RES.,FXD,CMPSN:5.1K OHM,5%,0.25W	01121	CB5125
R1597	311-1221-00			RES.,VAR,NONWIR:50 OHM,20%,0.50W	32997	3386F-T04-500
R1598	321-0107-00			RES.,FXD,FILM:127 OHM,1%,0.125W	91637	MFF1816G127ROF
R1599	321-0001-00			RES.,FXD,FILM:10 OHM,1%,0.125W	75042	CEAT0-10R00F
R1691	303-0150-00			RES.,FXD,CMPSN:15 OHM,5%,1W	01121	GB1505
R1692	321-0062-00			RES.,FXD,FILM:43.2 OHM,1%,0.125W	91637	MFF1816G43R20F
R1693	323-0140-00			RES.,FXD,FILM:280 OHM,1%,0.50W	75042	CECT0-2800F
R1694	323-0140-00			RES.,FXD,FILM:280 OHM,1%,0.50W	75042	CECT0-2800F
R1695	321-0228-00			RES.,FXD,FILM:2.32K OHM,1%,0.125W	91637	MFF1816G23200F
R1697	321-0201-00			RES.,FXD,FILM:1.21K OHM,1%,0.125W	91637	MFF1816G12100F
R1698	315-0363-00			RES.,FXD,CMPSN:36K OHM,5%,0.25W	01121	CB3635
R4401	321-0068-00			RES.,FXD,FILM:49.9 OHM,1%,0.125W	91637	MFF1816G49R90F
R4402	315-0301-00			RES.,FXD,CMPSN:300 OHM,5%,0.25W	01121	CB3015
R4403	321-0097-00			RES.,FXD,FILM:100 OHM,1%,0.125W	91637	MFF1816G100ROF
R4404	321-0097-00			RES.,FXD,FILM:100 OHM,1%,0.125W	91637	MFF1816G100ROF
R4406	315-0242-00			RES.,FXD,CMPSN:2.4K OHM,5%,0.25W	01121	CB2425
R4408	321-0095-00			RES.,FXD,FILM:95.3 OHM,1%,0.125W	91637	MFF1816G95R30F
R4409	321-0189-00			RES.,FXD,FILM:909 OHM,1%,0.125W	91637	MFF1816G909ROF
R4411	321-0068-00			RES.,FXD,FILM:49.9 OHM,1%,0.125W	91637	MFF1816G49R90F
R4412	315-0301-00			RES.,FXD,CMPSN:300 OHM,5%,0.25W	01121	CB3015

Replaceable Electrical Parts—465 Service (SN B250000-up)

Kct No.	Tektronix Part No.	Serial/Model No. Eff	Dscont	Name & Description	Mfr Code	Mfr Part Number
R4413	321-0097-00			RES.,FXD,FILM:100 OHM,1%,0.125W	91637	MFF1816G100ROF
R4414	321-0097-00			RES.,FXD,FILM:100 OHM,1%,0.125W	91637	MFF1816G100ROF
R4416	315-0242-00			RES.,FXD,CMPSN:2.4K OHM,5%,0.25W	01121	CB2425
R4418	311-1237-00			RES.,VAR,NONWIR:1K OHM,10%,0.50W	32997	3386X-T07-102
R4419	321-0189-00			RES.,FXD,FILM:909 OHM,1%,0.125W	91637	MFF1816G909ROF
R4421	321-0089-00			RES.,FXD,FILM:82.5 OHM,1%,0.125W	91637	MFF1816G82R50F
R4422	311-1278-00			RES.,VAR,NONWIR:250 OHM,10%,0.5W	32997	3329W-L58-251
R4423	315-0101-00			RES.,FXD,CMPSN:100 OHM,5%,0.25W	01121	CB1015
R4424	315-0101-00			RES.,FXD,CMPSN:100 OHM,5%,0.25W	01121	CB1015
R4425	311-1238-00			RES.,VAR,NONWIR:5K OHM,10%,0.50W	73138	72X-27-0.502K
R4427	311-1225-00			RES.,VAR,NONWIR:1K OHM,20%,0.50W	32997	3386F-T04-102
R4430	323-0147-00			RES.,FXD,FILM:332 OHM,1%,0.50W	75042	CECT0-3320F
R4431	317-0220-00			RES.,FXD,CMPSN:22 OHM,5%,0.125W	01121	BB2205
R4432	315-0101-00			RES.,FXD,CMPSN:100 OHM,5%,0.25W	01121	CB1015
R4433	323-0118-00			RES.,FXD,FILM:165 OHM,1%,0.50W	91637	MFF1226G165ROF
R4434	315-0100-00			RES.,FXD,CMPSN:10 OHM,5%,0.25W	01121	CB1005
R4435	321-0059-00			RES.,FXD,FILM:40.2 OHM,1%,0.125W	91637	MFF1816G40R20F
R4436	317-0100-00			RES.,FXD,CMPSN:10 OHM,5%,0.125W	01121	BB1005
R4437	317-0751-00			RES.,FXD,CMPSN:750 OHM,5%,0.125W	01121	BB7515
R4438	311-1260-00			RES.,VAR,NONWIR:250 OHM,10%,0.50W	32997	3329P-L58-251
R4440	323-0147-00			RES.,FXD,FILM:332 OHM,1%,0.50W	75042	CECT0-3320F
R4441	317-0220-00			RES.,FXD,CMPSN:22 OHM,5%,0.125W	01121	BB2205
R4442	315-0101-00			RES.,FXD,CMPSN:100 OHM,5%,0.25W	01121	CB1015
R4443	323-0118-00			RES.,FXD,FILM:165 OHM,1%,0.50W	91637	MFF1226G165ROF
R4444	315-0100-00			RES.,FXD,CMPSN:10 OHM,5%,0.25W	01121	CB1005
R4445	321-0059-00			RES.,FXD,FILM:40.2 OHM,1%,0.125W	91637	MFF1816G40R20F
R4448	315-0622-00			RES.,FXD,CMPSN:6.2K OHM,5%,0.25W	01121	CB6225
R4449	321-0193-00			RES.,FXD,FILM:1K OHM,1%,0.125W	91637	MFF1816G10000F
R4451	315-0820-00			RES.,FXD,CMPSN:82 OHM,5%,0.25W	01121	CB8205
R4452	315-0301-00			RES.,FXD,CMPSN:300 OHM,5%,0.25W	01121	CB3015
R4453	323-0157-00			RES.,FXD,FILM:422 OHM,1%,0.50W	91637	MFF1226G422ROF
R4462	321-0205-00			RES.,FXD,FILM:1.33K OHM,1%,0.125W	91637	MFF1816G13300F
R4463	321-0219-00			RES.,FXD,FILM:1.87K OHM,1%,0.125W	91637	MFF1816G18700F
R4464	321-0093-00			RES.,FXD,FILM:90.9 OHM,1%,0.125W	91637	MFF1816G90R90F
R4465	321-0126-00			RES.,FXD,FILM:200 OHM,1%,0.125W	91637	MFF1816G200ROF
R4466	311-1226-00			RES.,VAR,NONWIR:2.5K OHM,20%,0.50W	32997	3386F-T04-252
R4468	321-0031-00			RES.,FXD,FILM:20.5 OHM,1%,0.125W	91637	MFF1816G20R50F
R4469	323-0068-00			RES.,FXD,FILM:49.9 OHM,1%,0.50W	75042	CECT0-49R90F
R4474	321-0093-00			RES.,FXD,FILM:90.9 OHM,1%,0.125W	91637	MFF1816G90R90F
R4475	321-0126-00			RES.,FXD,FILM:200 OHM,1%,0.125W	91637	MFF1816G200ROF
R4478	321-0031-00			RES.,FXD,FILM:20.5 OHM,1%,0.125W	91637	MFF1816G20R50F
R4480	315-0100-00			RES.,FXD,CMPSN:10 OHM,5%,0.25W	01121	CB1005
R4481	301-0820-00			RES.,FXD,CMPSN:82 OHM,5%,0.50W	01121	EB8205
R4482	315-0820-00			RES.,FXD,CMPSN:82 OHM,5%,0.25W	01121	CB8205
R4483	310-0700-00	B250000	B294184	RES.,FXD,WW:430 OHM,1%,4W	80009	310-0700-00
R4483	308-0758-00	B294185		RES.,FXD,WW:430 OHM,1%,7W	14193	SP1151S-430ROF
R4485	301-0100-00			RES.,FXD,CMPSN:10 OHM,5%,0.50W	01121	EB1005
R4487	315-0180-00			RES.,FXD,CMPSN:18 OHM,5%,0.25W	01121	CB1805
R4491	301-0820-00			RES.,FXD,CMPSN:82 OHM,5%,0.50W	01121	EB8205
R4492	315-0820-00			RES.,FXD,CMPSN:82 OHM,5%,0.25W	01121	CB8205
R4493	310-0700-00	B250000	B294184	RES.,FXD,WW:430 OHM,1%,4W	80009	310-0700-00
R4493	308-0758-00	B294185		RES.,FXD,WW:430 OHM,1%,7W	14193	SP1151S-430ROF
R4497	315-0180-00			RES.,FXD,CMPSN:18 OHM,5%,0.25W	01121	CB1805

Replaceable Electrical Parts—465 Service (SN B25000-up)

Ckt No.	Tektronix Part No.	Serial/Model No. Eff	Discont	Name & Description	Mfr Code	Mfr Part Number
R4498	315-0100-00			RES., FXD, CMPSN:10 OHM, 5%, 0.25W	01121	CB1005
R4499	315-0100-00			RES., FXD, CMPSN:10 OHM, 5%, 0.25W	01121	CB1005
RT39	307-0124-00			RES., THERMAL:5K OHM, 10%	50157	1D1618
RT131	307-0124-00			RES., THERMAL:5K OHM, 10%	50157	1D1618
RT231	307-0124-00			RES., THERMAL:5K OHM, 10%	50157	1D1618
RT422	307-0181-00			RES., THERMAL:100K OHM, 10%, 4MW/DEG C	15454	1DE104-K-220EC
RT557	307-0124-00			RES., THERMAL:5K OHM, 10%	50157	1D1618
RT657	307-0124-00			RES., THERMAL:5K OHM, 10%	50157	1D1618
RT1230	307-0122-00			RES., THERMAL:50 OHM, 10%	50157	3D1515
RT1696	307-0124-00			RES., THERMAL:5K OHM, 10%	50157	1D1618
RT4448	307-0181-00			RES., THERMAL:100K OHM, 10%, 4MW/DEG C	15454	1DE104-K-220EC
S5 ¹						
S10 ¹	105-0342-01			DRUM, CAM SWITCH:VOLTS/DIV CH 1	80009	105-0342-01
S55 ¹						
S60 ²	105-0342-01			DRUM, CAM SWITCH:VOLTS/DIV CH 2	80009	105-0342-01
S112 ²						
S212 ³						
S225	260-1208-00			SWITCH, PUSH:DPDT	80009	260-1208-00
S338A	105-0423-00			ACTUATOR, SWITCH:	80009	105-0423-00
S338B	105-0421-00			ACTUATOR, SWITCH:	80009	105-0421-00
S350	260-1424-01			SWITCH, PUSH:	80009	260-1424-01
S400	260-1421-00			SWITCH, PUSH:1 STA, MOMENTARY, NON-SHORT	80009	260-1421-00
S510	105-0401-00			ACTUATOR, SWITCH:	80009	105-0401-00
S515	105-0399-00			ACTUATOR, SWITCH:	80009	105-0399-00
S530 ⁴						
S610	105-0400-00			ACTUATOR, SWITCH:	80009	105-0400-00
S615 ⁵	105-0399-00			ACTUATOR, SWITCH:	80009	105-0399-00
S630						
S1100	260-1422-00			SWITCH, PUSH:	80009	260-1422-00
S1120 ⁶	260-1423-00			SWITCH, PUSH:	80009	260-1423-00
S1140						
S1150 ⁷	263-1086-00			DRUM ASSY, CAM S:TIME/CM	80009	263-1086-00
S1155A, B						
S1239	260-1208-00			SWITCH, PUSH:DPDT	80009	260-1208-00
S1501	260-0834-00			SWITCH, TOGGLE:DPDT, 5A, 125VAC, 0.25-40 THD	09353	7201SN260-834-1B
S1502	260-0638-00			SW, THERMOSTATIC:10A, 240V, OPEN 75 DEG C	93410	110-364
S1503	260-1300-01			SWITCH, SLIDE:DPDT, 3A, 125V	82389	11A-1354
T354	120-0366-00			XFMR, TOROID:2 WINDINGS	80009	120-0366-00
T1420	120-0800-01			XFMR, PWR, SDN :MOLDED	80009	120-0800-01
T1501	120-0798-01			XFMR, PWR, STPDN:	80009	120-0798-01
U440	155-0115-00			MICROCIRCUIT, LI:CRT VERT DEFLECTION DRIVER	80009	155-0115-00
U540	155-0032-00			MICROCIRCUIT, LI:ML, PRE-AMPLIFIER	80009	155-0032-00
U640	155-0032-00			MICROCIRCUIT, LI:ML, PRE-AMPLIFIER	80009	155-0032-00
U870	155-0049-01			MICROCIRCUIT, DI:MONOLITHIC, SWEEP CONTROL	80009	155-0049-01
U1432	152-0552-00			SEMICONV DEVICE:V MULTR, 5KV IN, 15KV OUT	80009	152-0552-00
U1524	156-0158-00			MICROCIRCUIT, LI:DUAL OPERATIONAL AMPLIFIER	80009	156-0158-00
U1554	156-0158-00			MICROCIRCUIT, LI:DUAL OPERATIONAL AMPLIFIER	80009	156-0158-00
U1690	156-0281-00			MICROCIRCUIT, LI:4 TRANSISTOR ARRAY	80009	156-0281-00
V1440	154-0676-10	B250000	B274370	ELECTRON TUBE:CRT	80009	154-0676-10
V1440	154-0731-00	B274371		ELECTRON TUBE:W/ANODE LEAD	80009	154-0731-00
V1440	154-0731-04	XB274371		ELECTRON TUBE:CRT, P11, INT SCALE	80009	154-0731-04

¹See Mechanical Parts List for replacement parts.

²Furnished as a unit with R112.

³Furnished as a unit with R212.

⁴Furnished as a unit with R530.

⁵Furnished as a unit with R630.

⁶Furnished as a unit with R1140.

⁷Furnished as a unit with R1155.

Replaceable Electrical Parts—465 Service (SN B250000-up)

Ckt No.	Tektronix Part No.	Serial/Model No. Eff	Dscont	Name & Description	Mfr Code	Mfr Part Number
VR21	152-0166-00			SEMICON D DEVICE: ZENER, 0.4W, 6.2V, 5%	81483	69-9035
VR71	152-0166-00			SEMICON D DEVICE: ZENER, 0.4W, 6.2V, 5%	81483	69-9035
VR129	152-0166-00			SEMICON D DEVICE: ZENER, 0.4W, 6.2V, 5%	81483	69-9035
VR229	152-0166-00			SEMICON D DEVICE: ZENER, 0.4W, 6.2V, 5%	81483	69-9035
VR875	152-0278-00			SEMICON D DEVICE: ZENER, 0.4W, 3V, 5%	07910	1N4372A
VR896	152-0227-00			SEMICON D DEVICE: ZENER, 0.4W, 6.2V, 5%	80009	152-0227-00
VR1039	152-0166-00			SEMICON D DEVICE: ZENER, 0.4W, 6.2V, 5%	81483	69-9035
VR1099	152-0166-00			SEMICON D DEVICE: ZENER, 0.4W, 6.2V, 5%	81483	69-9035
VR1145	152-0395-00			SEMICON D DEVICE: ZENER, 0.4W, 4.3V, 5%	04713	1N749A
VR1146	152-0166-00			SEMICON D DEVICE: ZENER, 0.4W, 6.2V, 5%	81483	69-9035
VR1155	152-0278-00			SEMICON D DEVICE: ZENER, 0.4W, 3V, 5%	07910	1N4372A
VR1289	152-0166-00			SEMICON D DEVICE: ZENER, 0.4W, 6.2V, 5%	81483	69-9035
VR1428	152-0289-00			SEMICON D DEVICE: ZENER, 0.4W, 180V, 5%	04713	1N991B
VR1484	152-0286-00			SEMICON D DEVICE: ZENER, 0.4W, 75V, 5%	04713	1N982B
VR1515	152-0268-00			SEMICON D DEVICE: ZENER, 0.4W, 56V, 5%	04713	1N979B
VR1522	152-0411-00			SEMICON D DEVICE: ZENER, 0.25W, 9V, 5%	04713	1N937
VR1525	152-0283-00			SEMICON D DEVICE: ZENER, 0.4W, 43V, 5%	04713	1N976B
VR1526	152-0281-00			SEMICON D DEVICE: ZENER, 0.4W, 22V, 5%	04713	1N969B
VR1533	152-0304-00			SEMICON D DEVICE: ZENER, 0.4W, 20V, 5%	04713	1N968B
VR1570	152-0127-00			SEMICON D DEVICE: ZENER, 0.4W, 7.5V, 5%	04713	1N958B
VR4464	152-0195-00			SEMICON D DEVICE: ZENER, 0.4W, 5.1V, 5%	80009	152-0195-00
VR4481	152-0195-00			SEMICON D DEVICE: ZENER, 0.4W, 5.1V, 5%	80009	152-0195-00
VR4491	152-0195-00			SEMICON D DEVICE: ZENER, 0.4W, 5.1V, 5%	80009	152-0195-00

OPTION INFORMATION

Your instrument may be equipped with one or more options. This section describes those options, or directs the reader to where the option is documented.

			Pages
Option 4	EMI Environmental:	Described in this section.	2
Option 5	TV Sync Separator:	Documentation is available and may be ordered separately. Order 465 Option 5 Supplement 070-2191-00.	
Option 7*	EXT DC Operation:	Described in this section.	12
Option 78	P11 Phosphor:	Described in this section.	1

*Instruments containing DM do not have Option 7 available.

OPTION 4

INTRODUCTION

This section describes the features of Option 4 as it pertains to the 465 Oscilloscope. This circuitry modifies the instrument to meet additional conducted and radiated interference requirements over the frequency range of 150 kHz to 25 MHz (conducted) and 150 kHz to 1 GHz (radiated).

The following additions and changes were made to the standard circuitry to meet the specification requirements.

EMI filter (FL1501) added in series with the input power cord.

Cathode ray tube mesh filter installed to minimize crt faceplate radiation.

Four signal-output bnc connectors on the rear plenum chamber changed to a type that improves shielding of the connected signal leads.

Capacitors added across the transformer secondary windings.

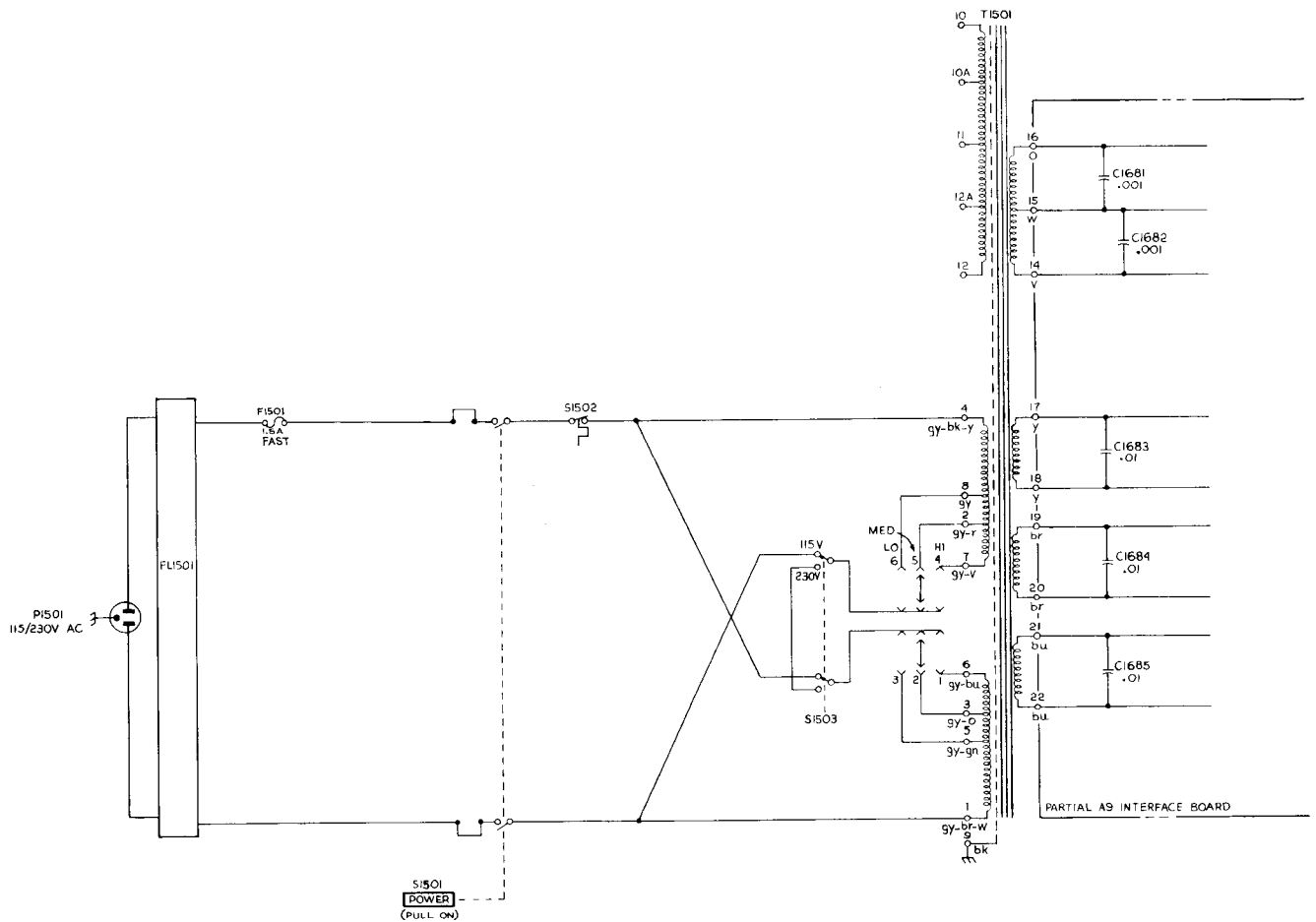

Fig. OPTION 4-1. 465 Option 4 primary winding with power line filter.

OPTION 4
REPLACEABLE PARTS LIST
ELECTRICAL

Ckt No.	Tektronix Part No.	Serial/Model No.		Name & Description	Mfr Code	Mfr Part Number
		Eff	Dscont			
C1681 ¹	283-0000-00			CAP.,FXD,CER DI:0.001UF,+100-0%,500V	72982	831-516E102P
C1682 ¹	283-0000-00			CAP.,FXD,CER DI:0.001UF,+100-0%,500V	72982	831-516E102P
C1683 ¹	283-0003-00			CAP.,FXD,CER DI:0.01UF,+80-20%,150V	72982	855-558Z5U-103Z
C1684 ¹	283-0003-00			CAP.,FXD,CER DI:0.01UF,+80-20%,150V	72982	855-558Z5U-103Z
C1685 ¹	283-0003-00			CAP.,FXD,CER DI:0.01UF,+80-20%,150V	72982	855-558Z5U-103Z
FL1501	119-0376-01			FILTER,RAD INT:2 X 3A,250V,400 HZ	80009	119-0376-01
J165	131-1315-00			CONNECTOR,RCPT,:BNC,FEMALE	24931	28JR235-1
J1318	131-1315-00			CONNECTOR,RCPT,:BNC,FEMALE	24931	28JR235-1
J1338	131-1315-00			CONNECTOR,RCPT,:BNC,FEMALE	24931	28JR235-1
J1450	131-1315-00			CONNECTOR,RCPT,:BNC,FEMALE	24931	28JR235-1

¹When instrument is equipped with both option 4 and option 7, only one set of these parts is used.

MECHANICAL

Fig. & Index No.	Tektronix Part No.	Serial/Model No.		Qty	1 2 3 4 5	Name & Description	Mfr Code	Mfr Part Number
		Eff	Dscont					
	119-0376-01			1		FILTER,RAD INT:(SEE FL1501 EPL) (ATTACHING PARTS)	80009	119-0376-01
	211-0038-00			1		SCREW,MACHINE:4-40 X 0.312"100 DEG,FLH STL	83385	OBD
	210-0586-00			1		NUT,PLAIN,EXT W:4-40 X 0.25 INCH,STL -----*	78189	OBD
	131-0707-00			1		CONTACT,ELEC:0.48"L,22-26 AWG WIRE	22526	75691-005
	131-0708-00			1		CONTACT,ELEC:0.48"L,28-32 AWG WIRE	22526	47437
	131-1310-00			1		CONTACT,ELEC:MESH FILTER GROUND	80009	131-1310-00
	-----			4		CONNECTOR,RCPT:(SEE J165,1318,1338,1450 EPL)		
	179-2162-00			1		WIRING HARNESS,:	80009	179-2162-00
	210-0774-00			2		EYELET,METALLIC:0.152 OD X 0.245 INCH L,BRS	80009	210-0774-00
	210-0775-00			2		EYELET,METALLIC:0.126 OD X 0.23 INCH L,BRS	80009	210-0775-00
	378-0726-00			1		FILTER,MESH,CRT:	80009	378-0726-00

OPTION 7

Option 7 is a dc to ac inverter that permits Tektronix Oscilloscopes to operate on 12 or 24 V dc with no performance deterioration. Circuitry is provided to protect against damage due to connection of 24 V when in the 12 V mode of operation.

The 24-volt external input permits use with conventional dc power (marine and aircraft).

Option 7 is an integral part of the oscilloscope. The modified oscilloscope has a three-position voltage input selection slide switch (visible through the right-hand side panel) at the rear of the line voltage selector switch. A dc input connector is located below the fan cover on the rear panel.

SPECIFICATIONS

AC Requirements

No increase in ac requirements over those of oscilloscopes not having Option 7.

DC Requirements

11.5 to 14 volts or 22 to 28 volts. 11.5-volt operation excludes graticule light operation and Option 5. Operating range may be extended to 15 volts or 30 volts with a series dropping resistor. Maximum elevation for + or - power lead is 50 V with respect to oscilloscope chassis ground.

Temperature

The same operating and non-operating range as the oscilloscope without Option 7.

SAFETY CONSIDERATIONS

Option 7 becomes a part of the modified instrument. The safety considerations for the unmodified instrument apply.

FUNCTION OF CONTROLS AND CONNECTORS

Mode Switch¹

AC Applies ac power to the oscilloscope power switch.

¹Be sure that the 1106 Line Selector switch is set to the correct line voltage for proper battery charging.

DC 12 Permits 12 V operation of the instrument from an external 12 V source.

DC 24 Permits 24 V operation of the instrument from either an external 24 V power source or from the 1106 Power Supply, which may be mechanically attached to the oscilloscope.

DC Input Connector

Option 7 mode switch and dc input connector are located on the modified oscilloscope.

OPERATION AND INSPECTION

Set the oscilloscope and Option 7 for the power source available as listed.

TABLE 1

Power Source	Oscilloscope Line Selector	Option 7 Mode Switch
115 V AC	115	AC
230 V AC	230	AC
12 V DC		12
24 V DC		24
1106 ¹		24

Turn the oscilloscope on. Check that the oscilloscope operates properly on any of the listed power sources that may be available.

Connect the oscilloscope frame to a ground (earth) reference before using.

CIRCUIT DESCRIPTION

Option 7 is a dc to ac inverter. It operates on 12 or 24 V dc. The circuit description is for 24 V operation unless noted otherwise. Refer to the schematic diagrams (Fig. Option 7-2 and 7-3) throughout the detailed circuit description.

The operating frequency of the inverter is approximately 400 Hz.

Options—465 Service (SN B250000 & up)

Simplified Block Diagram

See Fig. Option 7-1. The dc source is applied to the turn-off level circuit, the start circuit and the primary of T1501. If the dc source is above the level set by Turn-Off Level Adjustment R1613, the turn-off circuit does not operate.

The start circuit provides a large current surge through T1631 secondary to the bases of Q1652, Q1662, Q1654 and Q1664. This starts the inverter.

The turn-off circuit is activated in two ways. In 24 V operation, Q1622 is turned on by the source voltage dropping below 22 V. In 12 V mode of operation, Q1626 is turned on by the accidental application of 24 V dc.

Turn-Off Level Circuit

For the following description, refer to Fig. Option 7-2.

The voltage reference for the base of Q1606 is set by R1604, VR1604 and VR1605 for about 9.1 V. This establishes the junction of R1607 and the emitters of Q1606 and Q1608 at about 9.7 V. C1605 helps to hold the 9.1 V level, preventing inverter transients from activating the turn-off circuit and prevents Q1608 from turning on when the inverter is started. This allows the power source time to recover after providing the initial-start surge.

Source voltages higher than 22 V dc cause increased current through R1607, Q1606 and R1609. Q1608 is kept cut off by the increased voltage across R1609 and the resulting change across divider R1611-R1613-R1614. This permits no current through R1617. Since R1617 furnishes bias to Q1622, the transistor is cut off. This permits the collector of Q1622 and the rest of the turn-off circuit to rise to a voltage determined by the inverter circuit and the dc source voltage. The collector of Q1622 may be about 24 V (with respect to -dc) with a 12 V dc source and about 36 V with a 24 V dc source.

If the dc source voltage drops to less than 22 V, the current through divider R1609, R1611, R1613 and R1614 is decreased. Q1608 conducts, taking current from Q1606, and causing less drop across R1609. This makes Q1608 conduct more and Q1606 is cut off. Current flow through R1617 turns Q1622 on. Q1622 saturates, dropping its collector voltage to about 0.2 V. P1618 limits the maximum base current of Q1622.

During 12 V dc operation, there is no current flow through VR1604 and VR1605, since their series rating, about 18 volts, exceeds the applied voltage. The base current of Q1606, through R1605, turns Q1606 on enough to take all the current through R1607, which causes Q1608 to be cut off.

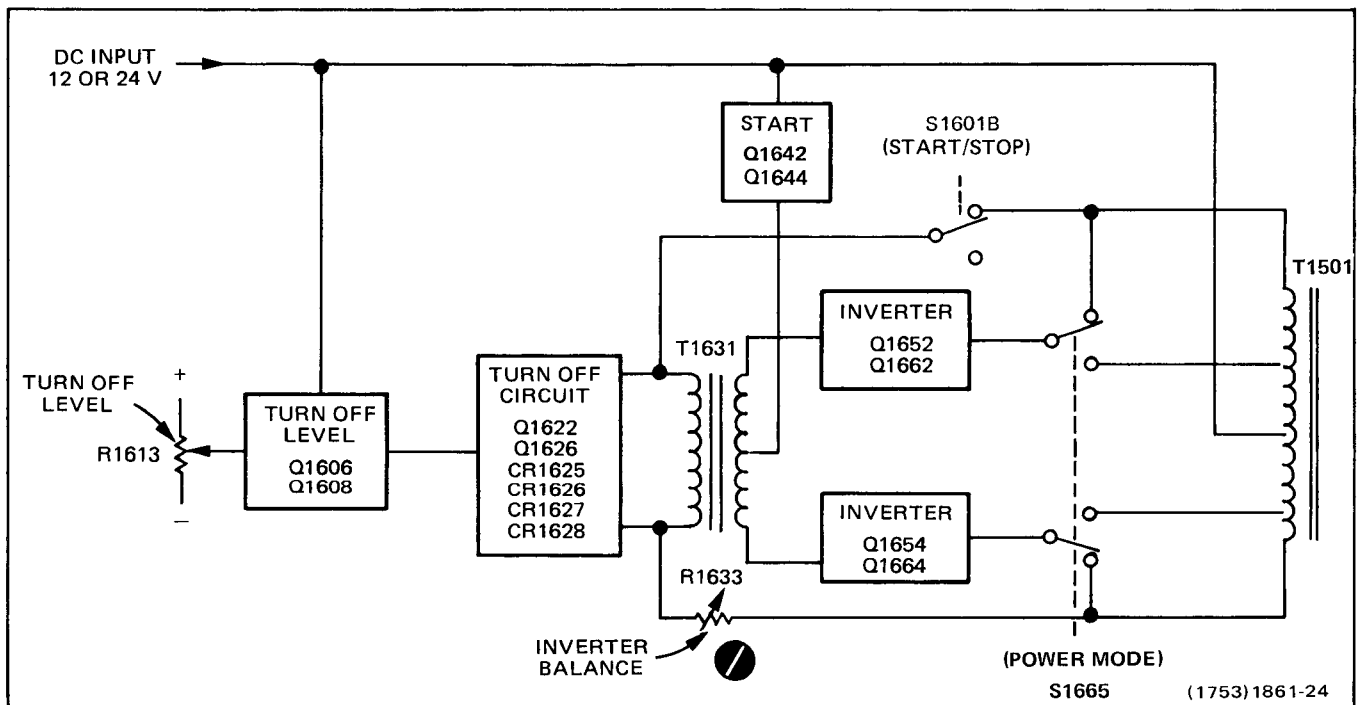

Fig. Option 7-1. Option 7 simplified block diagram.

Turn-Off Circuit

Q1622 is off under normal operating conditions until the dc source drops below 22 V and causes Q1622 to conduct. Q1622 does not conduct during 12 V dc operation, since the turn-off level circuit is disabled. CR1625, CR1626, CR1627, and CR1628 form a bridge rectifier. The inverter waveform is rectified to provide operating power for the turn-off circuit. C1626 filters the inverter spikes to keep them from firing Q1626 (scr). R1623 prevents C1626 from charging to the peak-to-peak inverter spikes.

Q1622 saturates when it is turned on. C1622 provides the high current path for feedback current via CR1625 or CR1626. Once the inverter is shut down, R1622 establishes a path to discharge C1622.

If 24 V dc is accidentally applied when the mode switch is in the 12 V position, transformer T1501 attempts to produce two times the correct feedback. This is sufficient to cause VR1622 to conduct. VR1622 provides the firing current for the scr, Q1626. Scr Q1626 fires and shorts out the bridge rectifier and the primary of T1631, stopping the inverter. R1625 prevents Q1626 from being fired by inverter noise. R1624 and C1626 provide holding current for Q1626, keeping it conducting until the surge created by the over-voltage conditions have terminated. CR1624 permits rapid charging of C1626.

Start Circuit

When S1601 is closed, the external dc source is applied to C1614, VR1641, and R1645. The initial surge is coupled to Q1642 through C1614, VR1639, and R1641. Transistor Q1642 saturates until C1614 charges through R1639 to the value determined by VR1639 and the base-emitter junction of Q1642 (about 5.7 volts), then Q1642 is cut off. R1641 limits the base current in Q1642. Zener diode VR1639, once C1614 is charged, makes Q1642 insensitive to input variations. R1642 limits Q1642 collector current. Q1644, R1645, and VR1641 provide a constant current during the time Q1642 is saturated, regardless of the dc source voltage. CR1643 is reverse biased by this starting current. The starting current is applied to the inverter transistors through T1631.

Inverter Circuit

The starting surge is applied to the bases of Q1652, Q1662, Q1654, and Q1664 through T1631, R1652, R1662, R1654, and R1664. Since the transistors do not have identical parameters, one pair will conduct before the other, and start the inverter. Operating base current is provided through CR1643.

R1626, R1631, and T1631 primary and secondary are the main frequency-determining components for the

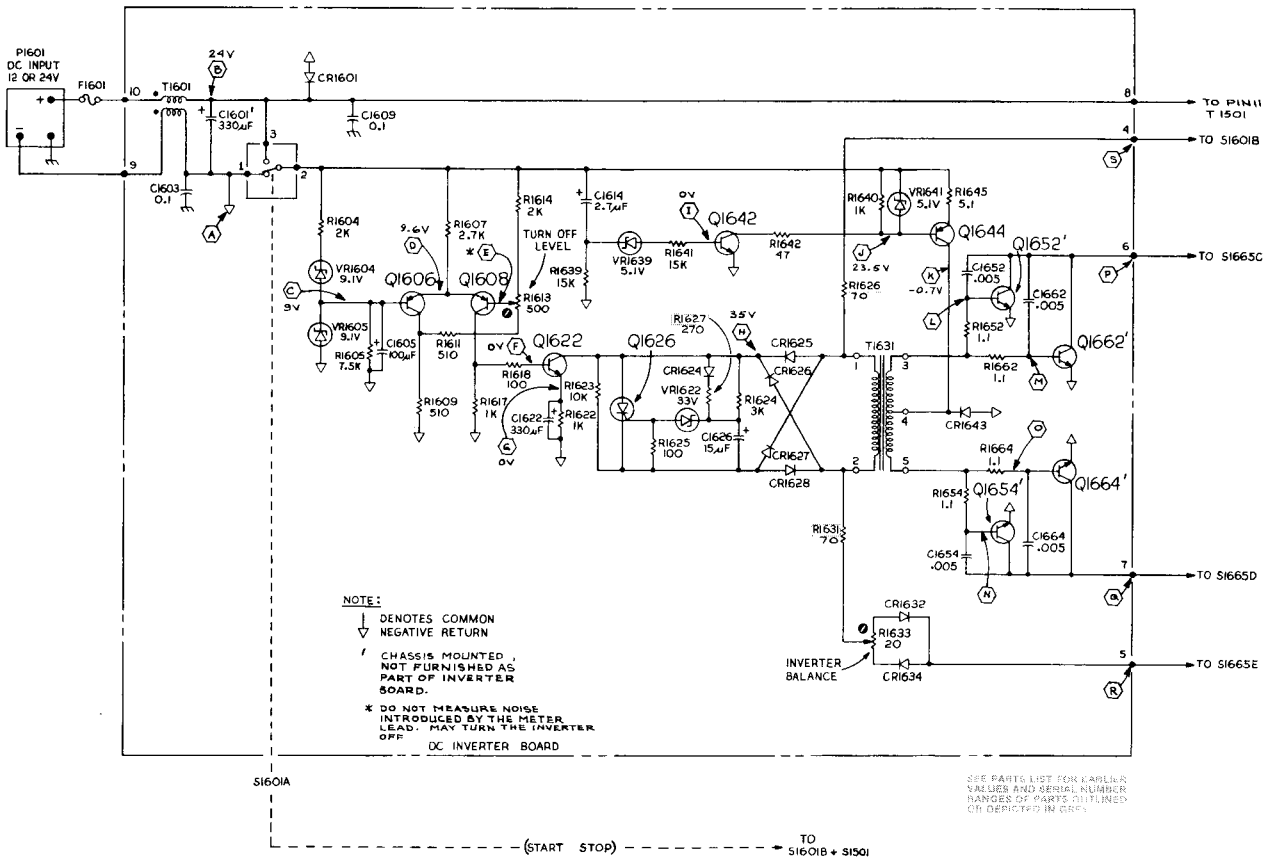

Fig. Option 7-2. 465 Option 7 DC Inverter.

Options—465 Service (SN B250000 & up)

inverter. Four base resistors, R1652, R1662, R1654, and R1664, distribute the drive evenly between the four transistors. C1652, C1662, C1654 and C1664 degenerate the high frequency response and reduce transients.

Feedback to maintain inverter operation is provided from T1501 primary to T1631 primary through R1626, R1631, R1633, CR1632 and CR1634. R1626 and R1631 provide frequency stability and current limiting. R1633, CR1632, and CR1634 compensate for differences in transistors and components. CR1632 and CR1634 conduct during different inverter half-cycles and permit R1633 to balance the drive to T1501.

C1681, C1682, C1683, C1684, and C1685 are added to the secondary of T1501 with Option 7 to provide optimum reduction of transients during inverter operation.

DC Input

External power is applied through P1601. CR1601 is normally reverse biased. If the wrong polarity external power is applied, CR1601 becomes forward biased and blows fuse F1601. Low-pass network T1601, C1601,

C1603, and C1609 is a filter to reduce transients to the dc source.

Start-Stop Switch

S1601. Section A in the off (stop) position discharges the capacitors in the turn-off and start circuits. This ensures the correct time constants when S1601 is changed to the on (start) position. In the start position, the dc input is applied to the inverter circuitry by S1601, Section A. At the same time S1601, section B is closed, completing the feedback loop for the inverter transistors, S1601, section B stops the inverter in the off position by opening the feedback loop between T1501 and T1631.

Power-Mode Switch (S1665)

See Fig. Option 7-3. Sections A and F connect filter C1671 and R1671 to T1501 during 12 or 24 V operation to reduce converter transients. Sections C and D select either transformer terminals 10A and 12A or 10 and 12, to provide the same secondary output when operating on 12 or 24 V. Sections B and E connect transformer terminals 10 and 12 to S1665, C and D, and to the inverter feedback circuit during both 12 and 24 V operation.

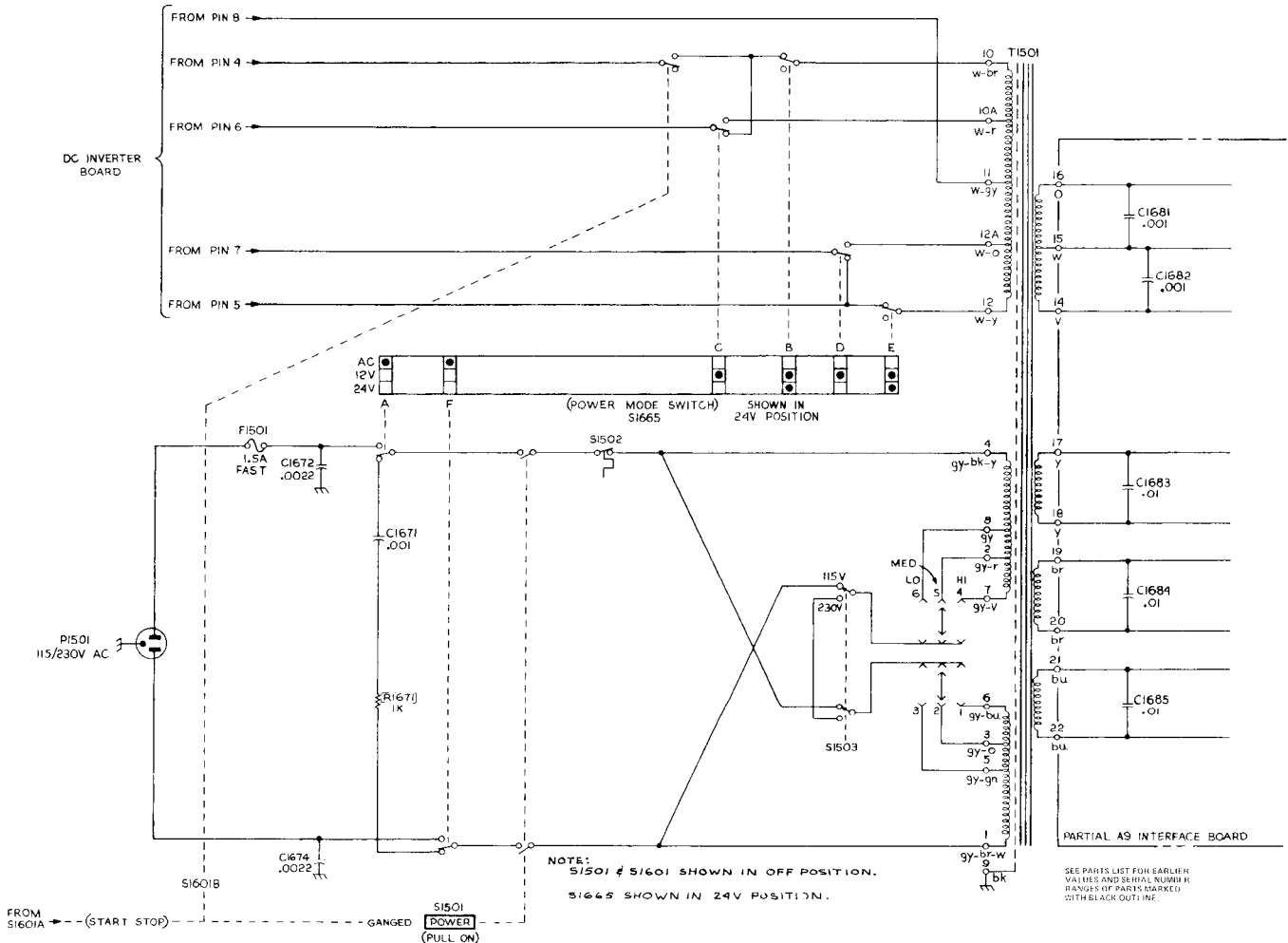

Fig. Option 7-3. 465 Option 7 primary winding.

MAINTENANCE

Obtaining Replacement Parts

STANDARD PARTS. All electrical and mechanical part replacements for Option 7 can be obtained through your local Tektronix Field Office or representative. However, many of the standard electronic components can be obtained locally in less time than is required to order them from Tektronix, Inc. Before purchasing or ordering replacement parts, check the parts list for value, tolerance, rating and description.

SPECIAL PARTS. In addition to the standard electronic components, some special components are used in Option 7. These components are manufactured or selected by Tektronix Inc., to meet specific performance requirements, or are manufactured for Tektronix, Inc., in accordance with our specifications. Most of the mechanical parts used in this instrument have been manufactured by Tektronix, Inc. Order all special parts directly from your local Tektronix Field Office or representative.

ORDERING PARTS. When ordering replacement parts from Tektronix, Inc., include the following information:

1. Instrument type.
2. Instrument serial number.
3. A description of the part (if electrical, include the circuit number).
4. Tektronix part number.

Circuit Board Chassis Removal

The circuit board is mounted on a small chassis located between the power transformer and the crt shield. To remove the chassis, remove three screws. Two thread-forming screws are located at the top of the chassis. One screw is at the bottom of the chassis and is removed from the right-hand side by going just below the power transformer.

CALIBRATION

Option 7 may be calibrated without removing it from the oscilloscope.

The reference letters (A), (B), etc., refer to points indicated on the schematic and circuit board illustrations.

Equipment Required

DC VOLTMETER. 22 V to 28 V.

TEST OSCILLOSCOPE. Used to verify the inverter balance adjustment. If the instrument under test and Option 7 are operational and the power source has a negative ground, they may be used as the test oscilloscope for this check.

DC POWER SOURCE. Voltage from 22 V to 28 V and from 11.5 V to 14 V. A source voltage of less than 22 volts will turn off Option 7 when it is operating in the 24 V mode. Starting current in 24 V mode is approximately 4 to 10 A. The dc source must be capable of handling this surge without dropping to 22 V or less. The 12 V starting surge is approximately 15 A.

NOTE

Option 7 is calibrated at the factory using a power supply (having the specifications listed first under the equipment required list). This permits the most accurate setting of the turn-off volts and inverter balance adjustments. Because this type of power supply may not be available, several alternative possibilities are given. The alternate power supplies have drawbacks, including voltage stability vs. time with high discharge rates. See Fig. Option 7-4.

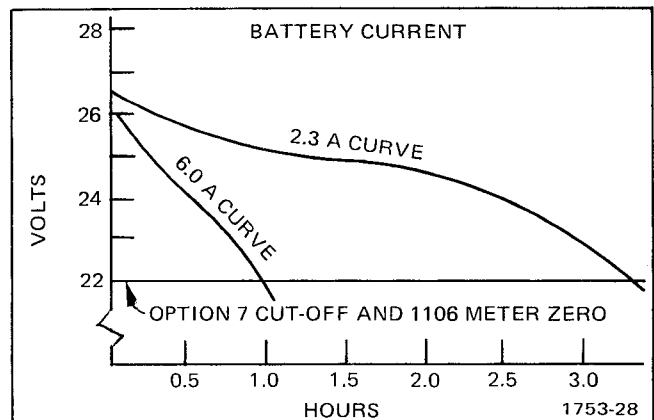

Fig. Option 7-4. Typical battery pack discharge curves.

1. Variable power supply with the aforementioned capabilities.
2. Variable power supply with an adequate current rating, in series with items 4 or 5.

Options—465 Service (SN B250000 & up)

3. 1106 Power Supply battery pack.²
4. Two 12-volt wet-cell storage batteries, in series, tapped at 20, 22, or 24 V.³
5. 18 to 23 Ni Cd cells, 4.0 amp hr (D cells) or greater, furnishing 20 to 28 V.³

CAUTION

This procedure is for an external dc source with the negative lead at ground potential (negative ground system).

Operating Range

a. Connect the dc source to the oscilloscope equipped with Option 7. Operate the oscilloscope in the 24 V mode. Connect the voltmeter between fuse, F1601 (B) and the common negative return (A). Vary the dc source from 28 V to 22 V.

CHECK—Oscilloscope should operate over the voltage range.

b. Change the dc source to 12 V. Operate the oscilloscope in the 12 V mode. Vary the dc source from 14 V to 11.5 V.

CHECK—Oscilloscope should operate over the voltage range.

²To set the turn-off level, the battery is charged above the cut-off point (22 V). An oscilloscope is connected and the battery allowed to discharge while its voltage is being monitored. As it reaches 22 V the turn-off point is set to cut off Option 7. The turn-off point on Option 7 approximately coincides with the meter zero on the 1106.

³This does not permit accurate adjustment of the turn-off level. Ni Cd batteries can be used, following the technique used for item 3.

Inverter Balance

NOTE

If the major oscilloscope use is with a 12-volt source, do this step while operating the oscilloscope and dc source on 12 volts.

Operate the oscilloscope in the 24 V mode. Set the dc source to 24 V. Connect the test oscilloscope between C1601 (C) and the common negative return (A).

CHECK—Signal should be flat. See Fig. Option 7-5.

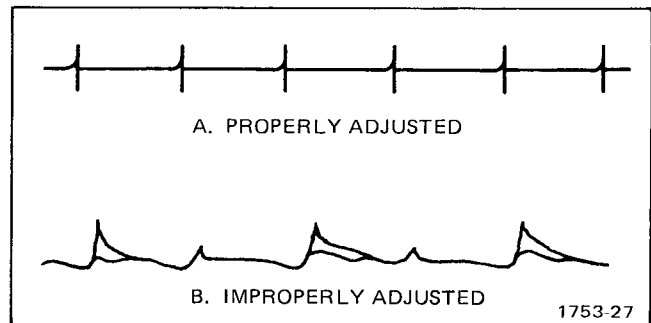

Fig. Option 7-5. Inverter Balance.

ADJUST—Inverter Balance (R1633) for the flattest signal.

NOTE

There is a slow drift (about a second) after the inverter balance adjustment has been moved. This is due to transistor characteristics and will require a slight Inverter Balance readjustment.

A very close approximation of the preceding method can be obtained by setting the inverter balance control for the minimum sound coming from the inverter.

Turn-Off Level

Set the dc source for 21.8 V.

ADJUST—Turn-Off Level (R1613) slowly until Option 7 turns off.

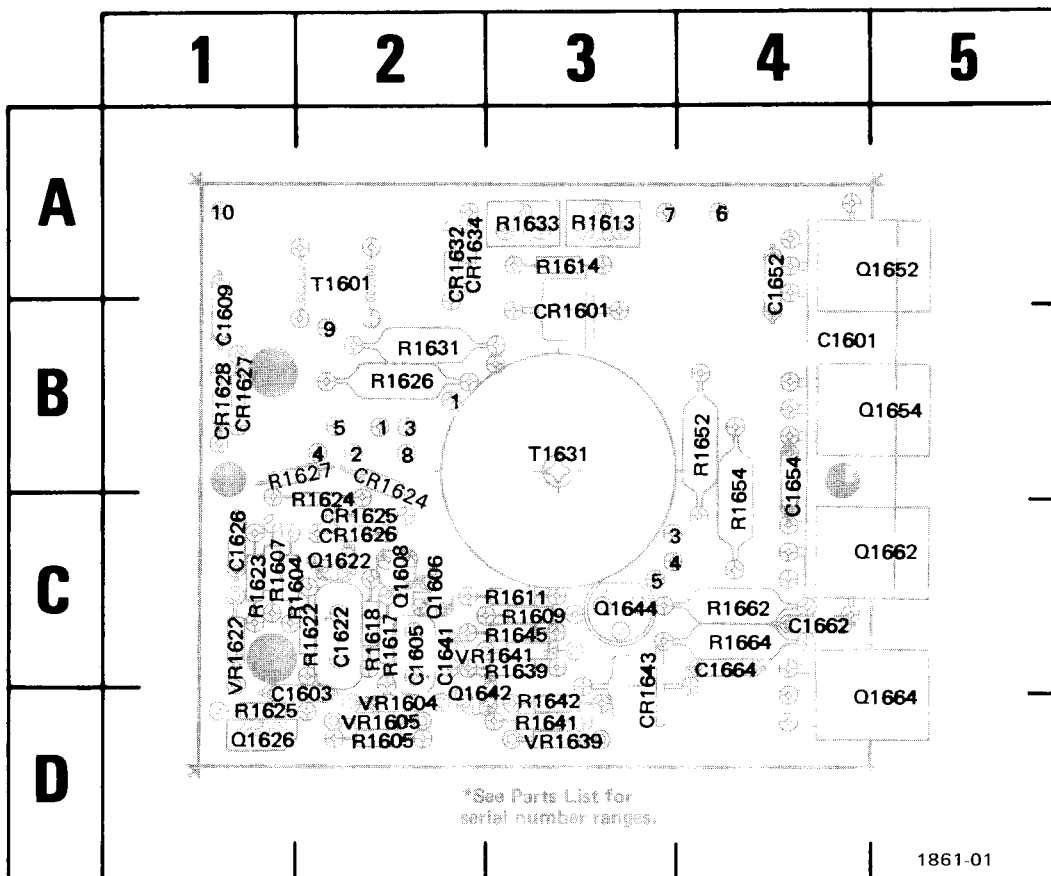

CKT NO	GRID LOC	CKT NO	GRID LOC	CKT NO	GRID LOC	CKT NO	GRID LOC
C1601	4B	CR1628	1B	R1605	2D	R1641	3D
C1603	2D	CR1632	2A	R1607	1C	R1642	3D
C1605	2C	CR1634	2A	R1609	3C	R1645	3C
C1609	1B	CR1643	3D	R1611	3C	R1652	4B
C1622	2C			R1613	3A	R1654	4B
C1626	1C	Q1606	2C	R1614	3A	R1662	4C
C1641	2C	Q1608	2C	R1617	2C	R1664	4C
C1652	4A	Q1622	2C	R1618	2C		
C1654	4B	Q1626	1D	R1622	2C	T1601	2A
C1662	4C	Q1642	2D	R1623	1C	T1631	3B
C1664	4C	Q1644	3C	R1624	2C		
		Q1652	5A	R1625	1D	VR1604	2D
		Q1654	5B	R1626	2B	VR1605	2D
CR1601	3B	Q1662	5C	R1627 *	1B	VR1622	1C
CR1624	2B	Q1664	5D	R1631	2B	VR1639	3D
CR1625	2C			R1633	3A	VR1641	3C
CR1626	2C	R1604	1C	R1639	3C		
CR1627	1B						

Fig. Option 7-8. Circuit board layout with component locator grid.

OPTION 7

REPLACEABLE ELECTRICAL PARTS

ABBREVIATIONS

ACTR	ACTUATOR	PLSTC	PLASTIC
ASSY	ASSEMBLY	QTZ	QUARTZ
CAP	CAPACITOR	RECP	RECEPTACLE
CER	CERAMIC	RES	RESISTOR
CKT	CIRCUIT	RF	RADIO FREQUENCY
COMP	COMPOSITION	SEL	SELECTED
CONN	CONNECTOR	SEMICOND	SEMICONDUCTOR
ELCTLT	ELECTROLYTIC	SENS	SENSITIVE
ELEC	ELECTRICAL	VAR	VARIABLE
INCAND	INCANDESCENT	WW	WIREWOUND
LED	LIGHT EMITTING DIODE	XFMR	TRANSFORMER
NONWIR	NON WIREWOUND	XTAL	CRYSTAL

ADDITIONAL PARTS ADDED TO STANDARD 465

Ckt No.	Tektronix Part No.	Serial/Model No. Eff	Dscont	Name & Description	Mfr Code	Mfr Part Number
C1601	290-0667-00			CAP., FXD, ELCTLT: 330UF, +75-10%, 50V	56289	500D158
C1671	283-0000-00			CAP., FXD, CER DI: 0.001UF, +100-0%, 500V	72982	831-516E102P
C1672 ¹	283-0263-00			CAP., FXD, CER DI: 0.0022UF, 20%, 3000V	56289	33C319
C1674 ¹	283-0263-00			CAP., FXD, CER DI: 0.0022UF, 20%, 3000V	56289	33C319
C1681 ²	283-0000-00			CAP., FXD, CER DI: 0.001UF, +100-0%, 500V	72982	831-516E102P
C1682 ²	283-0000-00			CAP., FXD, CER DI: 0.001UF, +100-0%, 500V	72982	831-516E102P
C1683 ²	283-0003-00			CAP., FXD, CER DI: 0.01UF, +80-20%, 150V	72982	855-558Z5U-103Z
C1684 ²	283-0003-00			CAP., FXD, CER DI: 0.01UF, +80-20%, 150V	72982	855-558Z5U-103Z
C1685 ²	283-0003-00			CAP., FXD, CER DI: 0.01UF, +80-20%, 150V	72982	855-558Z5U-103Z
F1601	159-0038-00			FUSE, CARTRIDGE: 3AG, 15A, 32V, FAST-BLOW	71400	MDL 15A
P1601	131-1333-00			CONNECTOR, RCPT, :POWER	80009	131-1333-00
Q1652	151-0436-00			TRANSISTOR: SILICON, NPN	80009	151-0436-00
Q1654	151-0436-00			TRANSISTOR: SILICON, NPN	80009	151-0436-00
Q1662	151-0436-00			TRANSISTOR: SILICON, NPN	80009	151-0436-00
Q1664	151-0436-00			TRANSISTOR: SILICON, NPN	80009	151-0436-00
RL671	302-0102-00	B250000	B255984	RES., FXD, CMPSN: 1K OHM, 10%, 0.50W	01121	EB1021
RL671	308-0077-00	B225985		RES., FXD, WW: 1K OHM, 10%, 3W	91637	RS2B-B10000
S1601	260-0834-00			SWITCH, TOGGLE: DPDT, 5A, 125VAC, 0.25-40 THD	09353	7201SN260-834-1B
S1665	105-0479-00			ACTUATOR, SWITCH:	80009	105-0479-00
S1665A	260-0760-00			SWITCH, SENS: 10A, 250V, SPDT, SNAP ACTION	01963	E62-10A
S1665B	260-0760-00			SWITCH, SENS: 10A, 250V, SPDT, SNAP ACTION	01963	E62-10A
S1665C	260-0760-00			SWITCH, SENS: 10A, 250V, SPDT, SNAP ACTION	01963	E62-10A
S1665D	260-0760-00			SWITCH, SENS: 10A, 250V, SPDT, SNAP ACTION	01963	E62-10A
S1665E	260-0760-00			SWITCH, SENS: 10A, 250V, SPDT, SNAP ACTION	01963	E62-10A
S1665F	260-0760-00			SWITCH, SENS: 10A, 250V, SPDT, SNAP ACTION	01963	E62-10A

¹Mounted on 465 rear panel. (These parts are not used when instrument is equipped with both option 4 and option 7.)

²When instrument is equipped with both option 4 and option 7, only one set of these capacitors is used.

Options 465 Service (SN B250000-up)

Ckt No.	Tektronix Part No.	Serial/Model No. Eff	Dscont	Name & Description	Mfr Code	Mfr Part Number
A14	670-2744-00	B250000	B290186	CKT BOARD ASSY:DC INVERTER	80009	670-2744-00
A14	670-2744-01	B290187		CKT BOARD ASSY:DC INVERTER	80009	670-2744-01
C1603	283-0178-00			CAP.,FXD,CER DI:0.1UF,+80-20%,100V	72982	8131N145 E 104Z
C1605	290-0531-00			CAP.,FXD,ELCTLT:100UF,20%,10V	90201	TDC107M010WLC
C1609	283-0178-00			CAP.,FXD,CER DI:0.1UF,+80-20%,100V	72982	8131N145 E 104Z
C1614	290-0573-00			CAP.,FXD,ELCTLT:2.7UF,20%,50V	56289	196D275X0050JAL
C1622	290-0533-00			CAP.,FXD,ELCTLT:330UF,20%,6V	05397	T368D337M006AZ
C1626	290-0528-00			CAP.,FXD,ELCTLT:15UF,20%,50V	90201	TDC156M050WLC
C1652	283-0110-00			CAP.,FXD,CER DI:0.005UF,+80-20%,150V	56289	19C24B
C1654	283-0110-00			CAP.,FXD,CER DI:0.005UF,+80-20%,150V	56289	19C242B
C1662	283-0110-00			CAP.,FXD,CER DI:0.005UF,+80-20%,150V	56289	19C242B
C1664	283-0110-00			CAP.,FXD,CER DI:0.005UF,+80-20%,150V	56289	19C242B
CR1601	152-0198-00			SEMICOND DEVICE:SILICON,200V,3A	04713	1N4721
CR1624	152-0333-00			SEMICOND DEVICE:SILICON,55V,200MA	80009	152-0333-00
CR1625	152-0107-00			SEMICOND DEVICE:SILICON,400V,400MA	80009	152-0107-00
CR1626	152-0107-00			SEMICOND DEVICE:SILICON,400V,400MA	80009	152-0107-00
CR1627	152-0107-00			SEMICOND DEVICE:SILICON,400V,400MA	80009	152-0107-00
CR1628	152-0107-00			SEMICOND DEVICE:SILICON,400V,400MA	80009	152-0107-00
CR1632	152-0333-00			SEMICOND DEVICE:SILICON,55V,200MA	80009	152-0333-00
CR1634	152-0333-00			SEMICOND DEVICE:SILICON,55V,200MA	80009	152-0333-00
CR1643	152-0198-00			SEMICOND DEVICE:SILICON,200V,3A	04713	1N4721
Q1606	151-0301-00			TRANSISTOR:SILICON,PNP	04713	2N2907A
Q1608	151-0301-00			TRANSISTOR:SILICON,PNP	04713	2N2907A
Q1622	151-0302-00			TRANSISTOR:SILICON,NPN	004713	2N2222A
Q1626	151-0506-00			TRANSISTOR:SILICON,SCR	03508	C106B2
Q1642	151-0302-00			TRANSISTOR:SILICON,NPN	04713	2N2222A
Q1644	151-0335-00			TRANSISTOR:SILICON,PNP	80009	151-0335-00
R1604	315-0202-00			RES.,FXD,CMPSN:2K OHM,5%,0.25W	01121	CB2025
R1605	315-0752-00			RES.,FXD,CMPSN:7.5K OHM,5%,0.25W	01121	CB7525
R1607	315-0272-00			RES.,FXD,CMPSN:2.7K OHM,5%,0.25W	01121	CB2725
R1609	315-0511-00			RES.,FXD,CMPSN:510 OHM,5%,0.25W	01121	CB5115
R1611	315-0511-00			RES.,FXD,CMPSN:510 OHM,5%,0.25W	01121	CB5115
R1613	311-1248-00			RES.,VAR,NONWIR:500 OHM,10%,0.50W	73138	72X-23-0-501K
R1614	315-0202-00			RES.,FXD,CMPSN:2K OHM,5%,0.25W	01121	CB2025
R1617	315-0102-00			RES.,FXD,CMPSN:1K OHM,5%,0.25W	01121	CB1025
R1618	315-0101-00			RES.,FXD,CMPSN:100 OHM,5%,0.25W	01121	CB1015
R1622	315-0102-00			RES.,FXD,CMPSN:1K OHM,5%,0.25W	01121	CB1025
R1623	315-0103-00			RES.,FXD,CMPSN:10K OHM,5%,0.25W	01121	CB1035
R1624	315-0302-00			RES.,FXD,CMPSN:3K OHM,5%,0.25W	01121	CB3025
R1625	316-0101-00			RES.,FXD,CMPSN:100 OHM,10%,0.25W	01121	CB1011
R1626	308-0451-00	B010100	B290186	RES.,FXD,WW:91 OHM,5%,3W	00213	1240S-91R00J
R1626	308-0450-00	B290187		RES.,FXD,WW:70 OHM,1%,3W	91637	RS2B-B70R00F
R1627	315-0271-00	XB294135		RES.,FXD,CMPSN:270 OHM,5%,0.25W	01121	CB2715
R1631	308-0451-00	B250000	B290186	RES.,FXD,WW:91 OHM,5%,3W	00213	1240S-91R00J
R1631	308-0450-00	B290187		RES.,FXD,WW:70 OHM,1%,3W	91637	RS2B-B70R00F
R1633	311-1501-00			RES.,VAR,NONWIR:20 OHM,10%,0.50W	73138	72X-37-0-200
R1639	315-0153-00			RES.,FXD,CMPSN:15K OHM,5%,0.25W	01121	CB1535
R1640	315-0102-00			RES.,FXD,CMPSN:1K OHM,5%,0.25W	01121	CB1025
R1641	315-0153-00			RES.,FXD,CMPSN:15K OHM,5%,0.25W	01121	CB1535
R1642	315-0470-00			RES.,FXD,CMPSN:47 OHM,5%,0.25W	01121	CB4705
R1645	307-0113-00			RES.,FXD,CMPSN:5.1 OHM,5%,0.25W	01121	CB51G5
R1652	308-0459-00			RES.,FXD,WW:1.1 OHM,5%,3W	91637	RS2B-D1R100J

Ckt No.	Tektronix Part No.	Serial/Model No. Eff	Dscont	Name & Description	Mfr Code	Mfr Part Number
R1654	308-0459-00			RES.,FXD,WW:1.1 OHM,5%,3W	91637	RS2B-D1R100J
R1662	308-0459-00			RES.,FXD,WW:1.1 OHM,5%,3W	91637	RS2B-D1R100J
R1664	308-0459-00			RES.,FXD,WW:1.1 OHM,5%,3W	91637	RS2B-D1R100J
T1601	120-0637-00			XFMR,TOROID:5 TURNS BIFILAR	80009	120-0637-00
T1631	120-0852-00			XFMR,TOROID:2 WINDINGS	80009	120-0852-00
VR1604	152-0306-00			SEMICONV DEVICE:ZENER,0.4W,9.1V,5%	81483	1N960B
VR1605	152-0306-00			SEMICONV DEVICE:ZENER,0.4W,9.1V,5%	81483	1N960B
VR1622	152-0241-00			SEMICONV DEVICE:ZENER,0.4W,33V,5%	04713	1N973B
VR1639	152-0279-00			SEMICONV DEVICE:ZENER,0.4W,5.1V,5%	80009	152-0279-00
VR1641	152-0279-00			SEMICONV DEVICE:ZENER,0.4W,5.1V,5%	80009	152-0279-00

OPTION 7

REPLACEABLE MECHANICAL PARTS

ABBREVIATIONS

BHB	binding head brass	h	height or high	OHB	oval head brass
BHS	binding head steel	hex.	hexagonal	OHS	oval head steel
CRT	cathode-ray tube	HHB	hex head brass	PHB	pan head brass
csk	countersunk	HHS	hex head steel	PHS	pan head steel
DE	double end	HSB	hex socket brass	RHS	round head steel
FHB	flat head brass	HSS	hex socket steel	SE	single end
FHS	flat head steel	ID	inside diameter	THB	truss head brass
Fil HB	fillister head brass	lg	length or long	THS	truss head steel
Fil HS	fillister head steel	OD	outside diameter	w	wide or width

Fig. & Index No.	Tektronix Part No.	Serial/Model No. Eff Dscont	Qty	1 2 3 4 5	Name & Description	Mfr Code	Mfr Part Number
9-1	441-1171-00		1		CHAS,ELEK EQUIP:DC INVERTER (ATTACHING PARTS)	80009	441-1171-00
	211-0008-00		2		SCREW,MACHINE:4-40 X 0.25 INCH,PNH STL	83385	OBD
	210-0938-00		2		WASHER,FLAT:0.109 ID X 0.25 INCH OD,STL	75497	AN960-3
					- - - * - - -		
-2	-----		1		CIRCUIT BOARD ASSY:INVERTER		
-3	136-0252-04		15		. SOCKET,PIN TERM:0.188 INCH LONG	22526	75060
-4	-----		1		. XFMR,TOROID:(SEE T1601 EPL) (ATTACHING PARTS)		
-5	343-0443-00		1		. RETAINER,XFMR:	80009	343-0443-00
-6	212-0011-00		1		. SCREW,MACHINE:8-32 X 0.750 INCH,FLH STL	83385	OBD
-7	210-0409-00		1		. NUT,PLAIN,HEX.:8-32 X 0.312 INCH,BRS	73743	3046-402
					- - - * - - -		
					(ATTACHING PARTS)		
-8	211-0116-00		2		SCR,ASSEM WSHR:4-40 X 0.312 INCH,PNH BRS	83385	OBD
					- - - * - - -		
-9	-----		4		TRANSISTOR:(SEE Q1652,Q1654,Q1662,Q1664 EPL) (ATTACHING PARTS)		
-10	210-0586-00		3		NUT,PLAIN,EXT W:4-40 X 0.25 INCH,STL	78189	OBD
-11	343-0451-00		1		RETAINER,XSTR:	80009	343-0451-00
-12	342-0195-00		1		INSULATOR,PLATE:0.70 X 3 INCHES LONG	08530	OBD
					- - - * - - -		
-13	348-0141-00		1		GROMMET,PLASTIC:U-SHP,0.625 X0.658 INCH	80009	348-0141-00
-14	348-0055-00		1		GROMMET,PLASTIC:0.25 INCH DIA	80009	348-0055-00
-15	352-0031-00		1		FUSEHOLDER:3AG FUSE	75915	357001
					(ATTACHING PARTS)		
-16	211-0507-00		1		SCREW,MACHINE:6-32 X 0.312 INCH,PNH STL	83385	OBD
-17	210-0006-00		1		WASHER,LOCK:INTL,0.146 IDX 0.288 OD,STL	78189	1206-00-00-0541C
-18	210-0407-00		1		NUT,PLAIN,HEX.:6-32 X 0.25 INCH,BRS	73743	3038-0228-402
					- - - * - - -		
	342-0228-00		1		INSULATOR,FILM:0.70 X 1.150 INCH LONG	80009	342-0228-00
-19	407-1341-00		1		BRACKET,SWITCH:INVERTER	80009	407-1341-00
					(ATTACHING PARTS)		
-20	211-0101-00		2		SCREW,MACHINE:4-40 X 0.25" 100 DEG,FLH STL	83385	OBD
					- - - * - - -		
-21	105-0479-00		1		ACTUATOR,SWITCH:INVERTER	80009	105-0479-00
-22	260-0760-00		6		SWITCH,SENS:10A,250V,SPDT,SNAP ACTION (ATTACHING PARTS)	01963	E62-10A
-23	211-0212-00		2		SCREW,MACHINE:2-56 X 1.75 INCH,PNH STL	83385	OBD
-24	210-0405-00		1		NUT,PLAIN,HEX.:2-56 X 0.188 INCH,BRS	73743	2X12157-402
					- - - * - - -		
-25	386-2649-00		1		PLATE,ACT GUIDE:INVERTER	80009	386-2649-00
	214-1925-00		1		SPRING,SW ACT:POWER SOURCE	80009	214-1925-00
-26	260-0834-00		1		SWITCH,TOGGLE:DPDT,5A,125VAC,0.25-40 THD (ATTACHING PARTS)	09353	7201SN260-834-1B
-27	210-0562-00		1		. NUT,PLAIN,HEX.:0.25-40 X 0.312 INCH,BBS	73743	2X20224-402
-28	210-0046-00		1		WASHER,LOCK:INTL,0.26 ID X 0.40" OD,STL	78189	1214-05-00-0541C
					- - - * - - -		
	179-1963-00		1		WIRING HARNESS,:	80009	179-1963-00
	348-0005-00		1		GROMMET,RUBBER:0.50 INCH DIA	70485	230
	200-1414-03		1		COVER,SCOPE:REAR	80009	200-1414-03
	131-1333-00		1		CONNECTOR,RCPT,:POWER (ATTACHING PARTS)	80009	131-1333-00
	211-0101-00		2		SCREW,MACHINE:4-40 X 0.25" 100 DEG,FLH STL	83385	OBD
	348-0365-00		4		FOOT,CABINET:PLASTIC,W/LATCH GROOVE (ATTACHING PARTS)	80009	348-0365-00
					- - - * - - -		
					ACCESSORIES		
	161-0094-00		1		CABLE,ASSY,PWR:3 WIRE,36 INCHES LONG	80009	161-0094-00

OPTION 7 EXPLODED

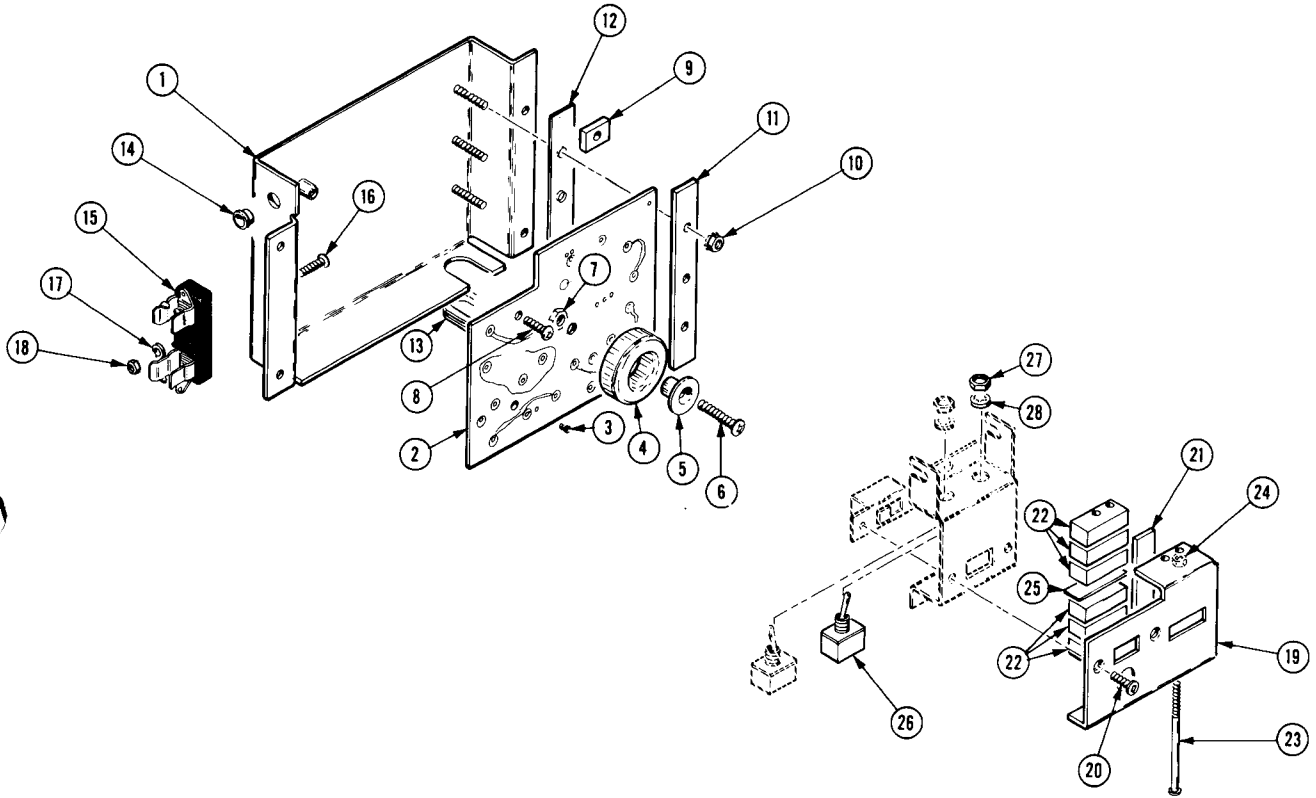

Fig. Option 7-9

C

C

C

OPTION 78

This option adds a Type P11 phosphor CRT to the instrument.

If this option is being added to an instrument which is already equipped with a different phosphor, or if the cathode-ray tube requires replacement, use the following procedure:

Parts List Changes

DELETE:

V1440	154-0676-10	CRT, P31 Phosphor
-------	-------------	-------------------

1). Follow the crt removal and installation procedure in the maintenance section of this manual.

ADD:

V1440	154-0676-14	CRT, P11 Phosphor
-------	-------------	-------------------

2). After completing crt installation, check Table 6-1 (Adjustment Interactions) for calibration adjustments which may require re-adjustment.

DIAGRAMS AND CIRCUIT BOARD ILLUSTRATIONS

Symbols and Reference Designators

Electrical components shown on the diagrams are in the following units unless noted otherwise:

Capacitors = Values one or greater are in picofarads (pF).
 Values less than one are in microfarads (μF).

Resistors = Ohms (Ω).

Graphic symbols and class designation letters are based on ANSI Standard Y32.2-1975.

Logic symbology is based on ANSI Y32.14-1973 in terms of positive logic. Logic symbols depict the logic function performed and may differ from the manufacturer's data.

The overline on a signal name indicates that the signal performs its intended function when it goes to the low state.

Abbreviations are based on ANSI Y1.1-1972.

Other ANSI standards that are used in the preparation of diagrams by Tektronix, Inc. are:

- Y14.15, 1966 Drafting Practices.
- Y14.2, 1973 Line Conventions and Lettering.
- Y10.5, 1968 Letter Symbols for Quantities Used in Electrical Science and Electrical Engineering.

The following prefix letters are used as reference designators to identify components or assemblies on the diagrams.

A	Assembly, separable or repairable (circuit board, etc)	H	Heat dissipating device (heat sink, heat radiator, etc)	S	Switch or contactor
AT	Attenuator, fixed or variable	HR	Heater	T	Transformer
B	Motor	HY	Hybrid circuit	TC	Thermocouple
BT	Battery	J	Connector, stationary portion	TP	Test point
C	Capacitor, fixed or variable	K	Relay	U	Assembly, inseparable or non-repairable (integrated circuit, etc.)
CB	Circuit breaker	L	Inductor, fixed or variable	V	Electron tube
CR	Diode, signal or rectifier	M	Meter	VR	Voltage regulator (zener diode, etc.)
DL	Delay line	P	Connector, movable portion	W	Wirestrap or cable
DS	Indicating device (lamp)	Q	Transistor or silicon-controlled rectifier	Y	Crystal
E	Spark Gap, Ferrite bead	R	Resistor, fixed or variable	Z	Phase shifter
F	Fuse	RT	Thermistor		
FL	Filter				

The following special symbols may appear on the diagrams:

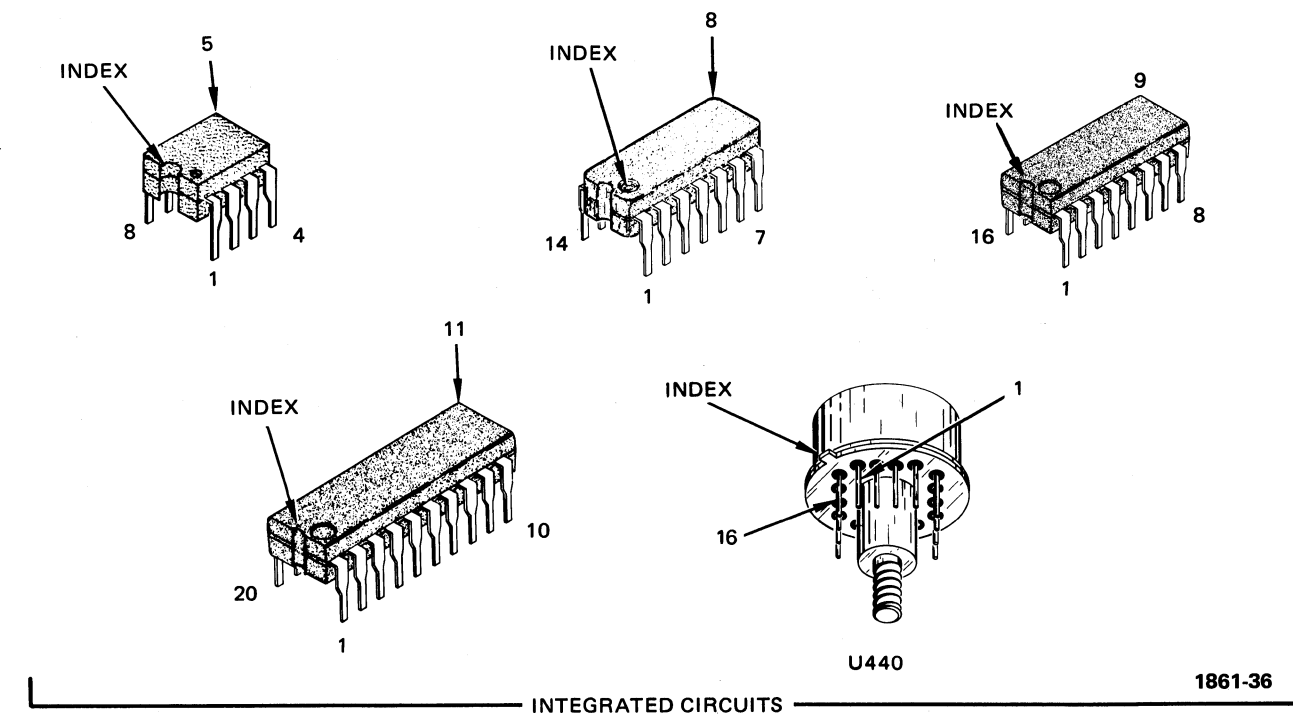
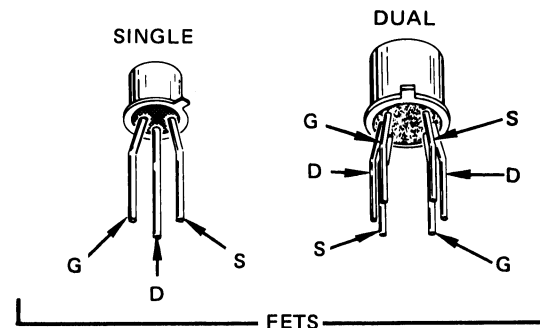
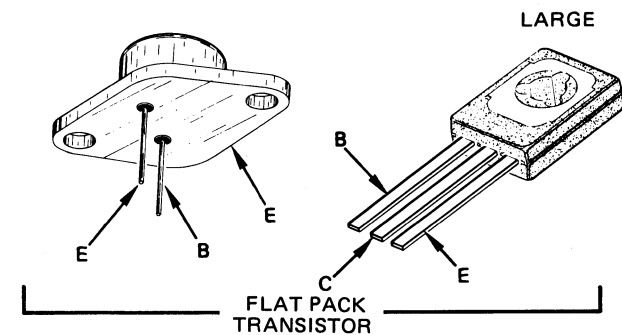
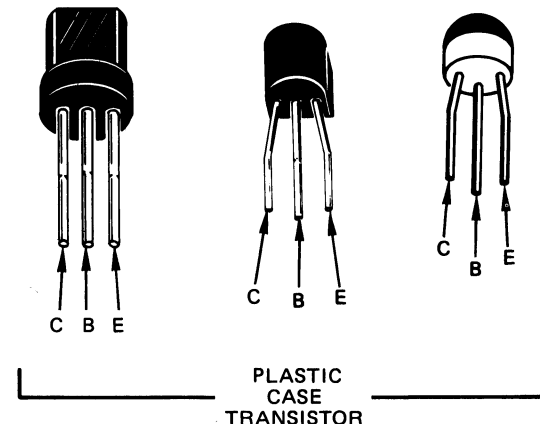
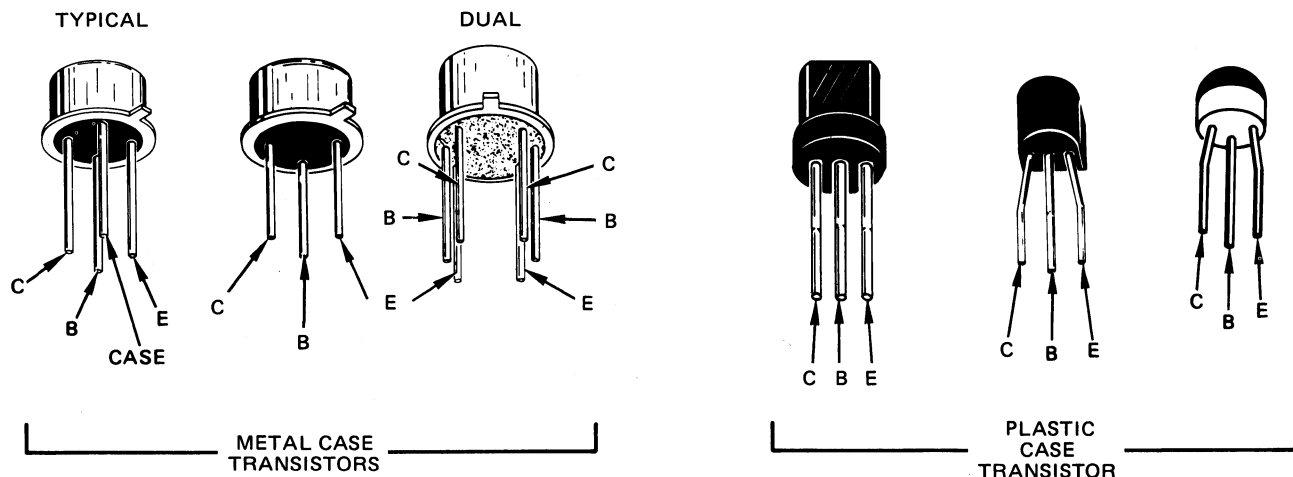
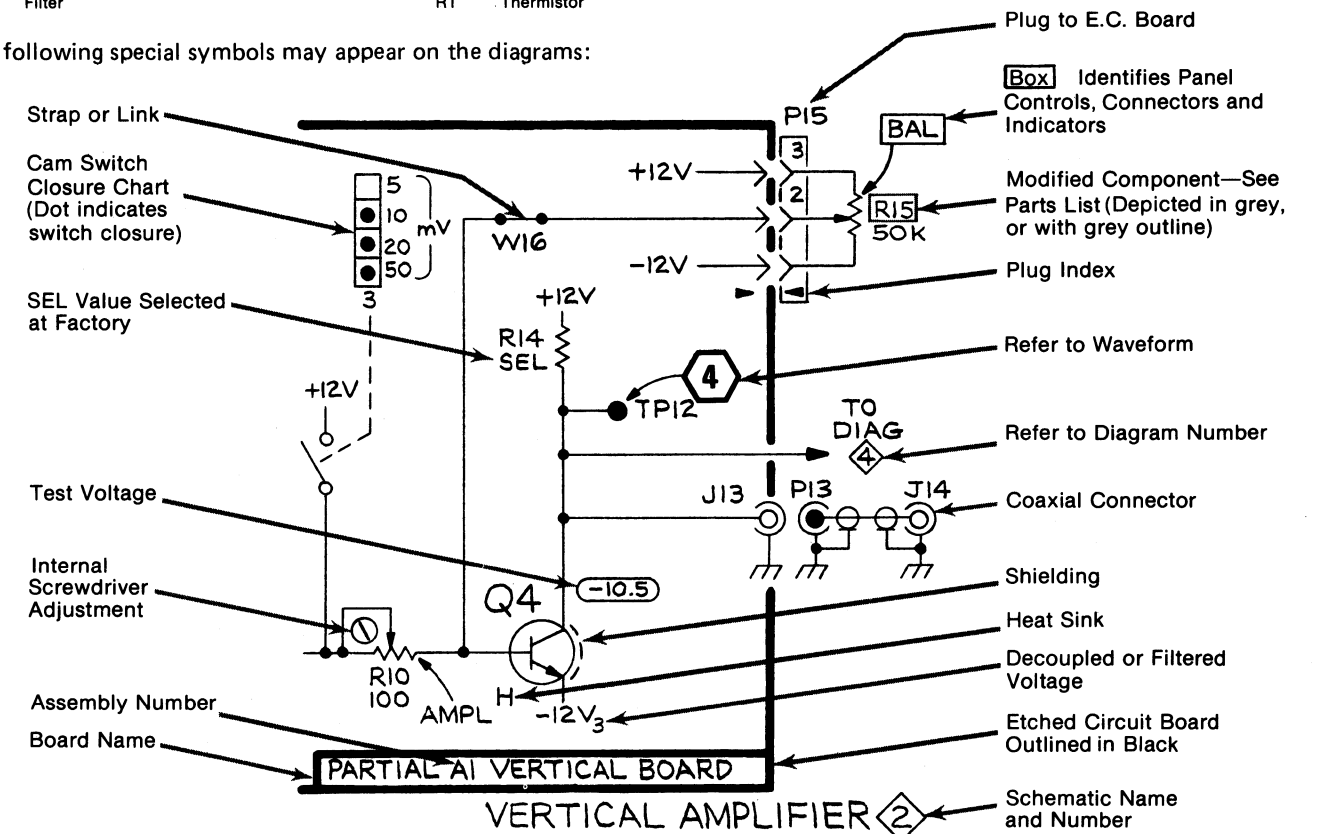

Fig. 8-1. Semiconductor lead configurations.

A4 BOARD COMPONENTS VOLTAGE & WAVEFORM SETUP

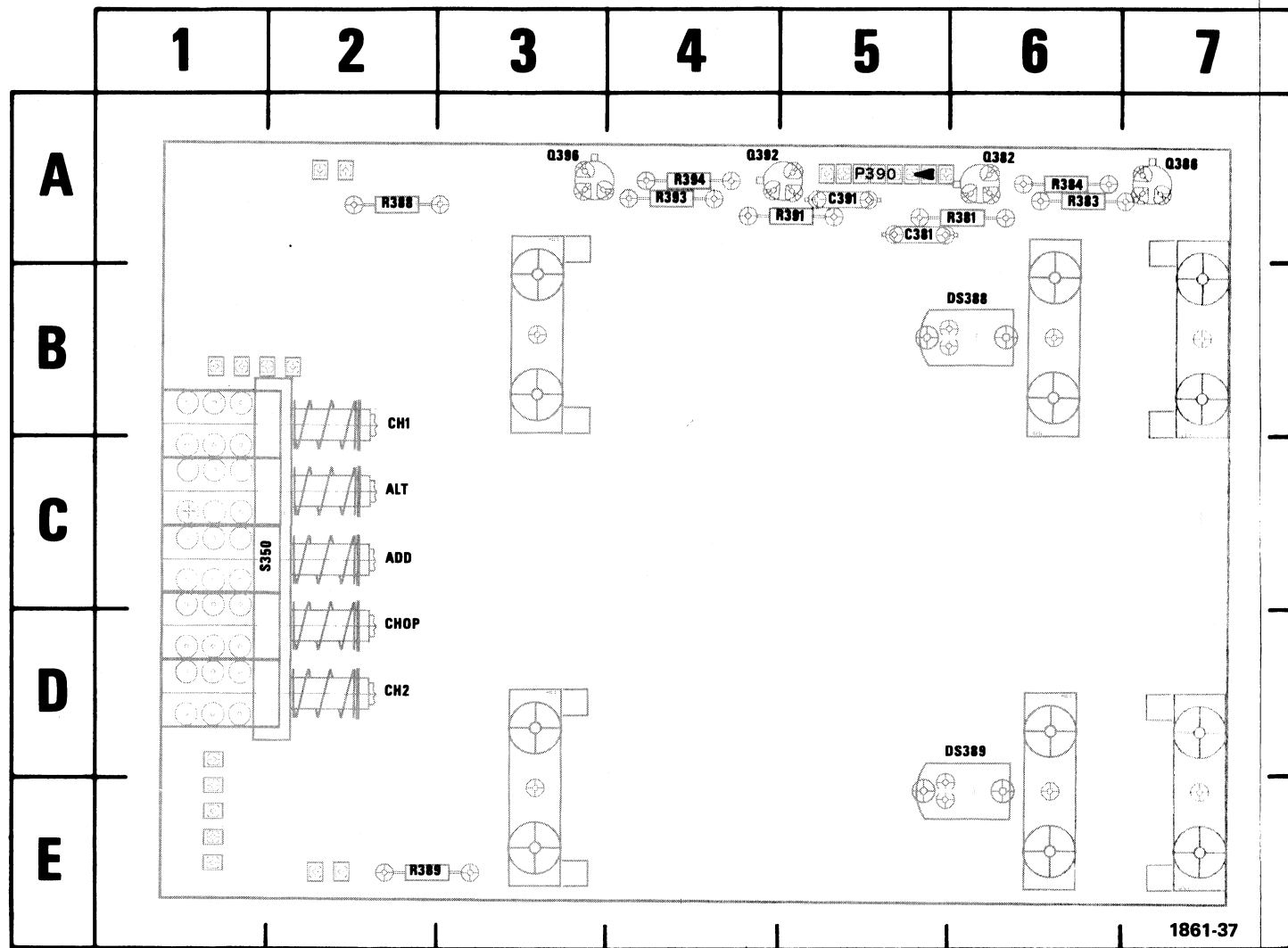
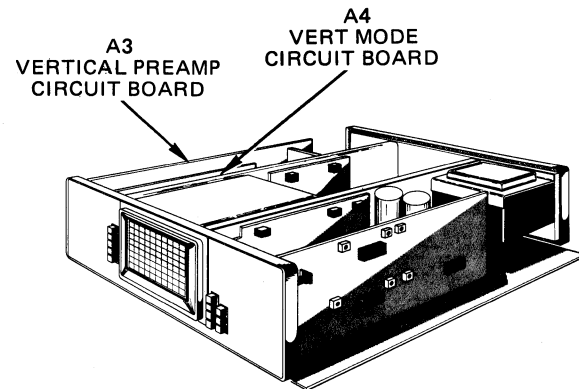

Fig. 8-2. A4—Vertical Mode Switch circuit board.

†Located on back of board.

*See Parts List for serial number ranges.

CKT NO	GRID LOC	CKT NO	GRID LOC
C381	5A	R381	6A
C391	5A	R382†*	6A
		R383	6A
DS388	6B	R384	6A
DS389	6D	R388	2A
P390	5A	R389	2E
Q382	6A	R391	5A
Q386	7A	R392†*	
Q392	4A	R393	4A
Q396	3A	R394	4A
		S350	1C



WAVEFORMS

The waveforms adjacent to the circuit diagrams were obtained using the recommended test equipment and setup given below unless otherwise noted. Waveforms may vary from instrument to instrument and with the tolerance of test equipment being used.

RECOMMENDED TEST EQUIPMENT

Item	Specifications	Recommended Type
Test Oscilloscope	Frequency Response: Dc-100 MHz Deflection Factor: 5 mV/div to 5 V/Div Input Impedance: 1 mΩ, 20 pF Sweep Rate: 5 ms to 2 μs/div	Tektronix 465 or equivalent
Probe (2 required)	Fast-rise 10X probe compatible with the vertical amplifier of the test oscilloscope.	Tektronix P6065A.Type included with test oscilloscope.
Probe	1X probe compatible with the 465 vertical amplifier	Tektronix P6011 (for trigger-view waveforms only)

465 SETUP

Apply the 465 calibrator signal to the Channel 1 input via a 10X probe (supplied with the 465). Connect the 465 A +Gate (from the rear panel) to the test oscilloscope external trigger input via a 42-inch unterminated BNC cable.

Sweep Controls

A TIME/DIV	1 ms
B TIME/DIV	0.2 ms
VAR	Calibrated detent
DELAY TIME POSITION	5.00
HORIZ DISPLAY	MIX
X10 MAG (IN)	OFF (button out)
POSITION	Midrange
FINE	Midrange

465 CONTROL SETTINGS

CRT Controls

INTENSITY	As desired
FOCUS	As desired
SCALE ILLUM	As desired

Vertical Controls (both Channels if applicable)

VOLTS/DIV	50 mV (6 divisions of vertical display)
VAR	Calibrated detent
POSITION	Midrange
AC-GND-DC	DC
VERT MODE	CH 1
INVERT	Off (button out)
20 MHz BW LIMIT	Off (no yellow showing)

Triggering Controls (both A and B unless otherwise noted)

COUPLING	AC
A LEVEL	As needed for a stable display
B LEVEL	As needed for a stable B portion of the mixed sweep.
SLOPE	+
SOURCE	NORM
TRIG MODE	AUTO
A TRIG HOLDOFF	NORM

Connect the probe to the back of the oscilloscope to which it applies.

Connect the probe to the back of the oscilloscope to which it applies.

Test Oscilloscope: All controls noted below.

Vertical Input: Vertical Mode: Volts/Div

Digital Multimeter: voltages up to

DC Voltmeter: above 1 kV).

WAVEFORMS

The waveforms adjacent to the circuit diagrams were obtained using the recommended test equipment and setup given below unless otherwise noted. Waveforms may vary from instrument to instrument and with the tolerance of test equipment being used.

RECOMMENDED TEST EQUIPMENT

Item	Specifications	Recommended Type
Test Oscilloscope	Frequency Response: Dc-100 MHz Deflection Factor: 5 mV/div to 5 V/Div Input Impedance: 1 m Ω , 20 pF Sweep Rate: 5 ms to 2 μ s/div	Tektronix 465 or equivalent
Probe (2 required)	Fast-rise 10X probe compatible with the vertical amplifier of the test oscilloscope.	Tektronix P6065A. Type included with test oscilloscope.
Probe	1X probe compatible with the 465 vertical amplifier	Tektronix P6011 (for trigger-view waveforms only)

465 SETUP

Apply the 465 calibrator signal to the Channel 1 input via a 10X probe (supplied with the 465). Connect the 465 A +Gate (from the rear panel) to the test oscilloscope external trigger input via a 42-inch unterminated BNC cable.

465 CONTROL SETTINGS

CRT Controls

INTENSITY	As desired
FOCUS	As desired
SCALE ILLUM	As desired

Vertical Controls (both Channels if applicable)

VOLTS/DIV	50 mV (6 divisions of vertical display)
VAR	Calibrated detent
POSITION	Midrange
AC-GND-DC	DC
VERT MODE	CH 1
INVERT	Off (button out)
20 MHz BW LIMIT	Off (no yellow showing)

Sweep Controls

A TIME/DIV	1 ms
B TIME/DIV	0.2 ms
VAR	Calibrated detent
DELAY TIME POSITION	5.00
HORIZ DISPLAY	MIX
X10 MAG (IN)	OFF (button out)
POSITION	Midrange
FINE	Midrange

Triggering Controls (both A and B unless otherwise noted)

COUPLING	AC
A LEVEL	As needed for a stable display
B LEVEL	As needed for a stable B portion of the mixed sweep.
SLOPE	+
SOURCE	NORM
TRIG MODE	AUTO
A TRIG HOLDOFF	NORM

TEST OSCILLOSCOPE SETUP

Connect the 465 A +Gate (from the rear panel) to the Test Oscilloscope external trigger input via a 42 inch unterminated BNC cable.

Trigger Source	External
Trigger Coupling	AC
Trigger Mode	Auto

Connect a 10X probe to the channel one input. Apply the probe to the test point or component lead indicated on the back of the pullout page preceding the circuit diagram to which it applies.

Time/Division	As noted on each waveform
Horizontal Position	To position the beginning of the display 1 division from the left graticule edge. This will allow time comparison of the waveforms. The beginning of the Test Oscilloscope display will be coincident with the beginning of the 465 A sweep.

Test Oscilloscope Control Settings

All controls as needed for the best display except as noted below:

Vertical Input Coupling	AC
Vertical Mode	Channel 1
Volts/Division	As noted on each waveform

DC VOLTAGES

Typical voltage measurements were obtained under the following conditions unless otherwise noted on the individual diagrams. Voltage measurements were taken with no signal applied to the vertical or trigger inputs. All voltages measured with reference to chassis ground. Voltages rounded to the nearest tenth of a volt. Voltages may vary from instrument to instrument and with the tolerance of test equipment being used.

RECOMMENDED TEST EQUIPMENT

Item	Specifications	Example
Digital Multimeter (for voltages up to 1 kV)	Range: 0 to 1 kV Input Impedance: 10 M Ω	Tektronix DM 501 Digital Multimeter
DC Voltmeter (for voltages above 1 kV).	Range: 0 to 3 kV Input Impedance: 20 K Ω /V	Triplett Model 630NA

465 CONTROL SETTINGS (WHEN DC VOLTAGES ARE MEASURED)

CRT Controls

INTENSITY	Normal display intensity
FOCUS	Best focused trace
SCALE ILLUM	Fully clockwise

Vertical Controls (both channels unless otherwise noted)

VERT MODE	ALT
POSITION	
CH 1	Two divisions above center
CH 2	Two divisions below center
VOLTS/DIV	5 mV
AC-GND-DC	GND
INVERT	Off (button out)
20 MHz BW LIMIT	Off (no yellow showing)

Trigger Controls (A and B unless otherwise noted)

COUPLING	AC
A SOURCE	NORM
B SOURCE	STARTS AFTER DELAY
LEVEL	Midrange
SLOPE	+
A TRIG HOLDOFF	NORM
TRIG MODE	AUTO

A and B Sweep Controls

X10 MAG	Off (button out)
POSITION and FINE	Midrange
HORIZ MODE	A INTEN
DELAY TIME POSITION	5.00
A TIME/DIV	1 ms
B TIME/DIV	.1 ms

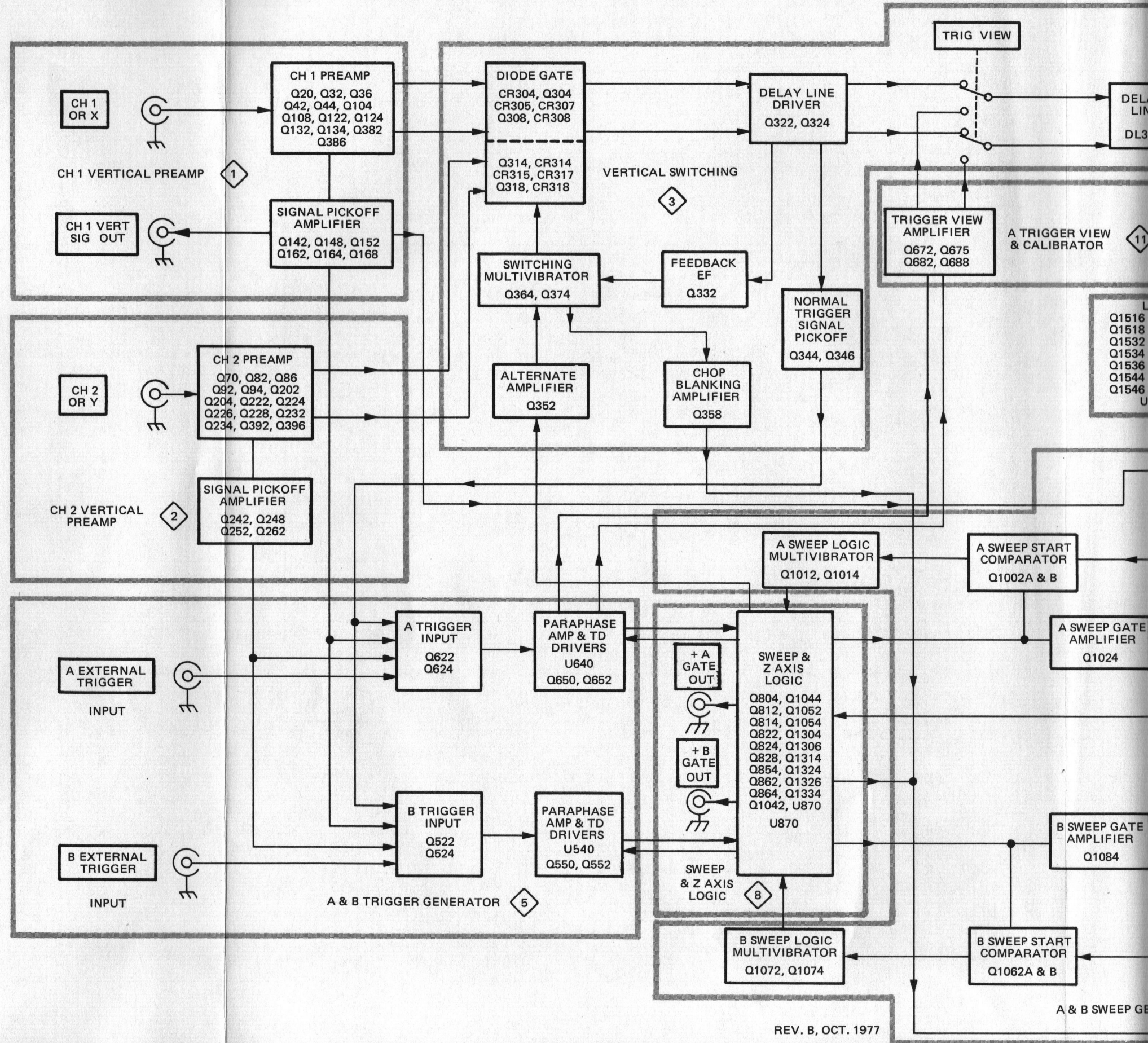

REV. B, OCT. 1977

1861-38

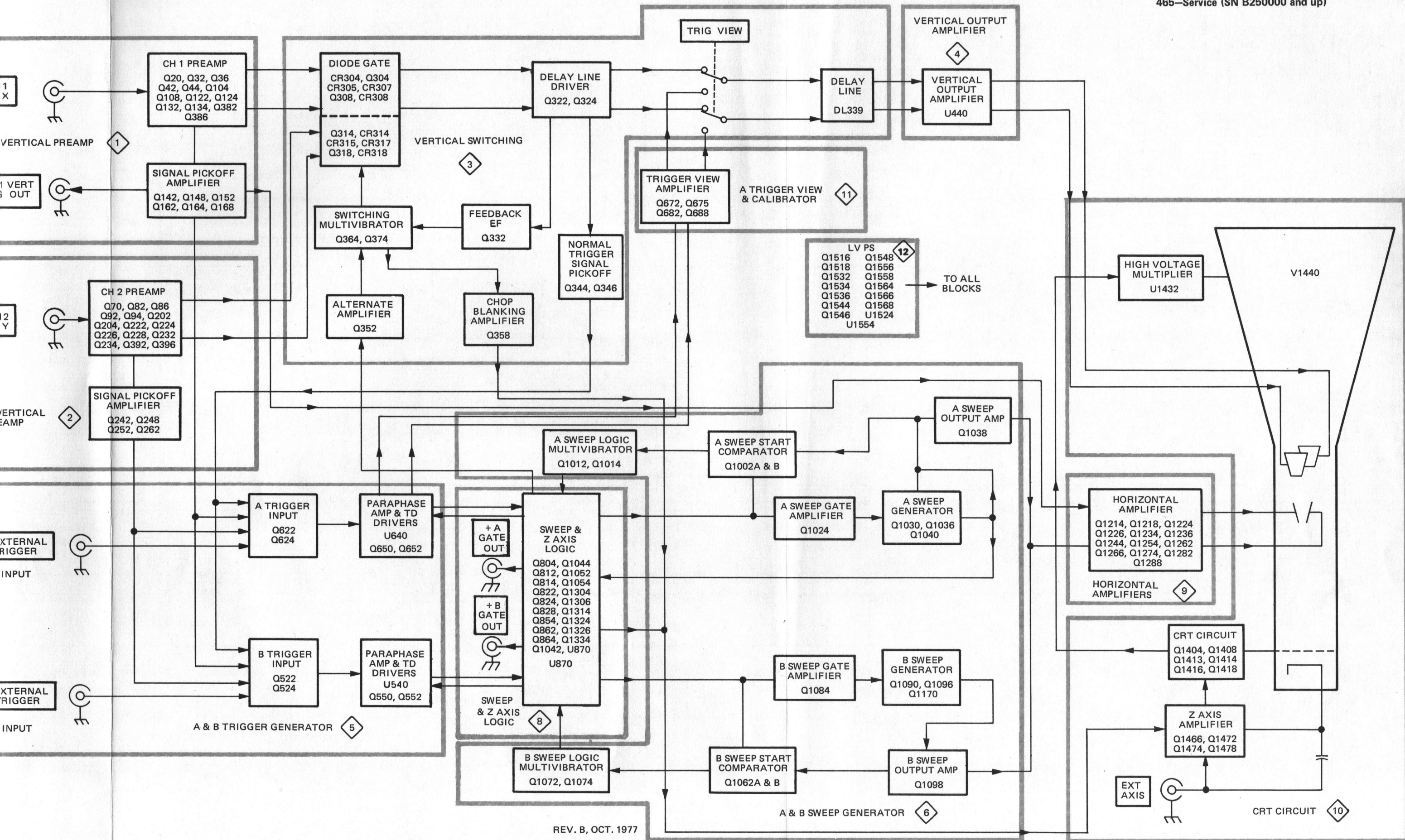

REV. B, OCT. 1977

1861-38

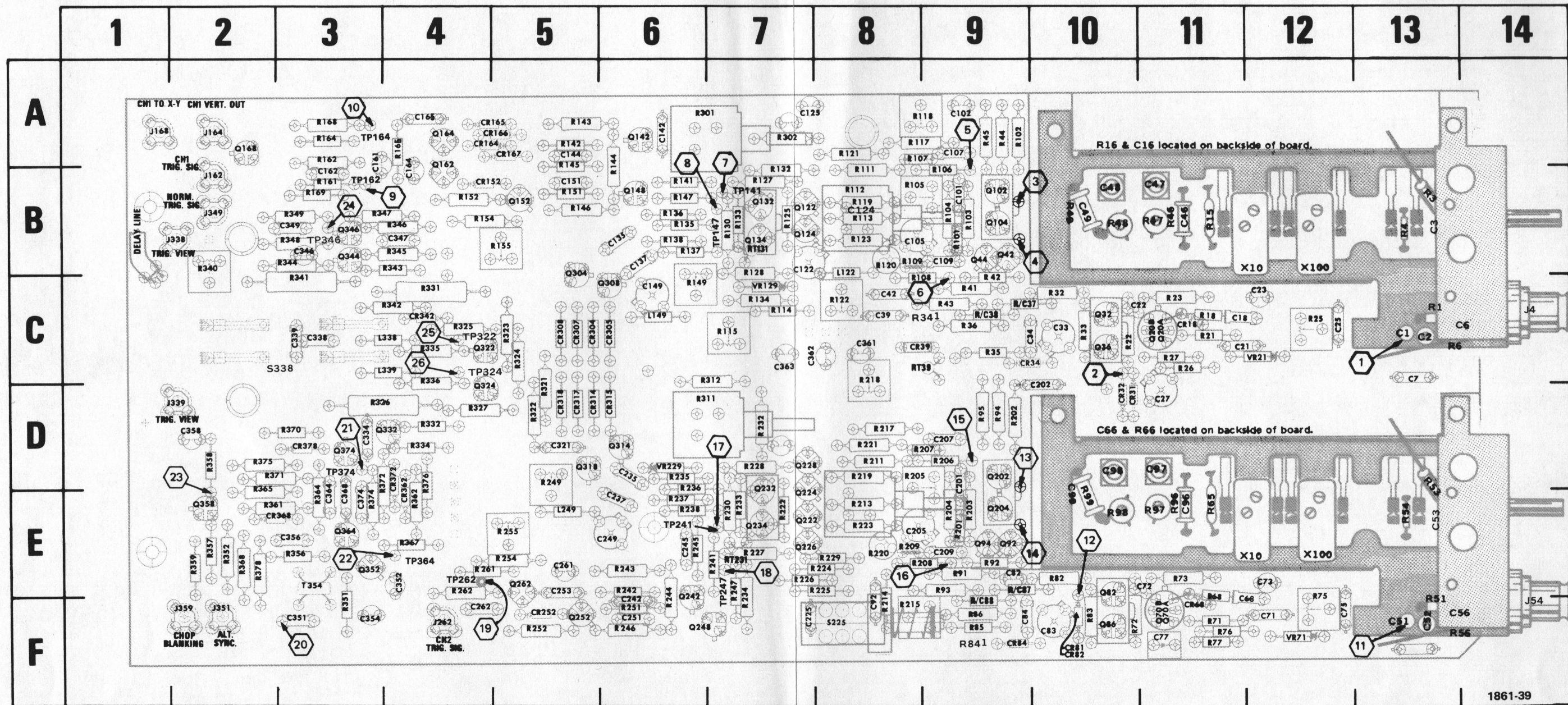

† Located on back of board
 † Not used with 670-3023 Vertical Output board

Fig. 8-3. A1 & A2—Attenuators and A3—Vertical Preamp circuit boards.

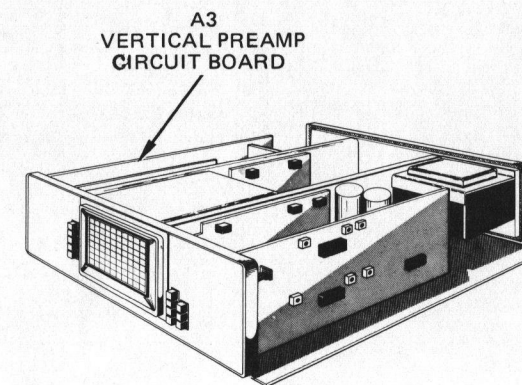

CKT NO	GRID LOC
C1	13C
C2	13C
C3	13E
C6	13C
C7	13C
C18	11C
C21	11C
C22	11C
C23	12C
C25	12C
C27	11C
C33	10C
C34	10C
C36	10C
C37	9C
C38	9C
C39	8C
C42	8C
C46	11E
C47	11E
C48	10E
C49	10E
C51	13F
C52	13F
C53	13F
C56	13F
C57†	
C68	12E
C71	12E
C72	11E
C73	12E
C75	12E
C77	11E
C82	9E
C83	10E
C84	9F
C87	9E
C88	9F
C92	8F
C96	11E
C97	11E
C98	10E
C99	10E
C101	9B
C102	9A
C105	8B
C107	9A
C109	9B
C122	7B
C124	8B
C125	7A
C135	6B
C137	6B
C142	6A
C144	5A
C149	6C
C151	5B
C161	3A
C162	3B
C164	4B
C165	4A

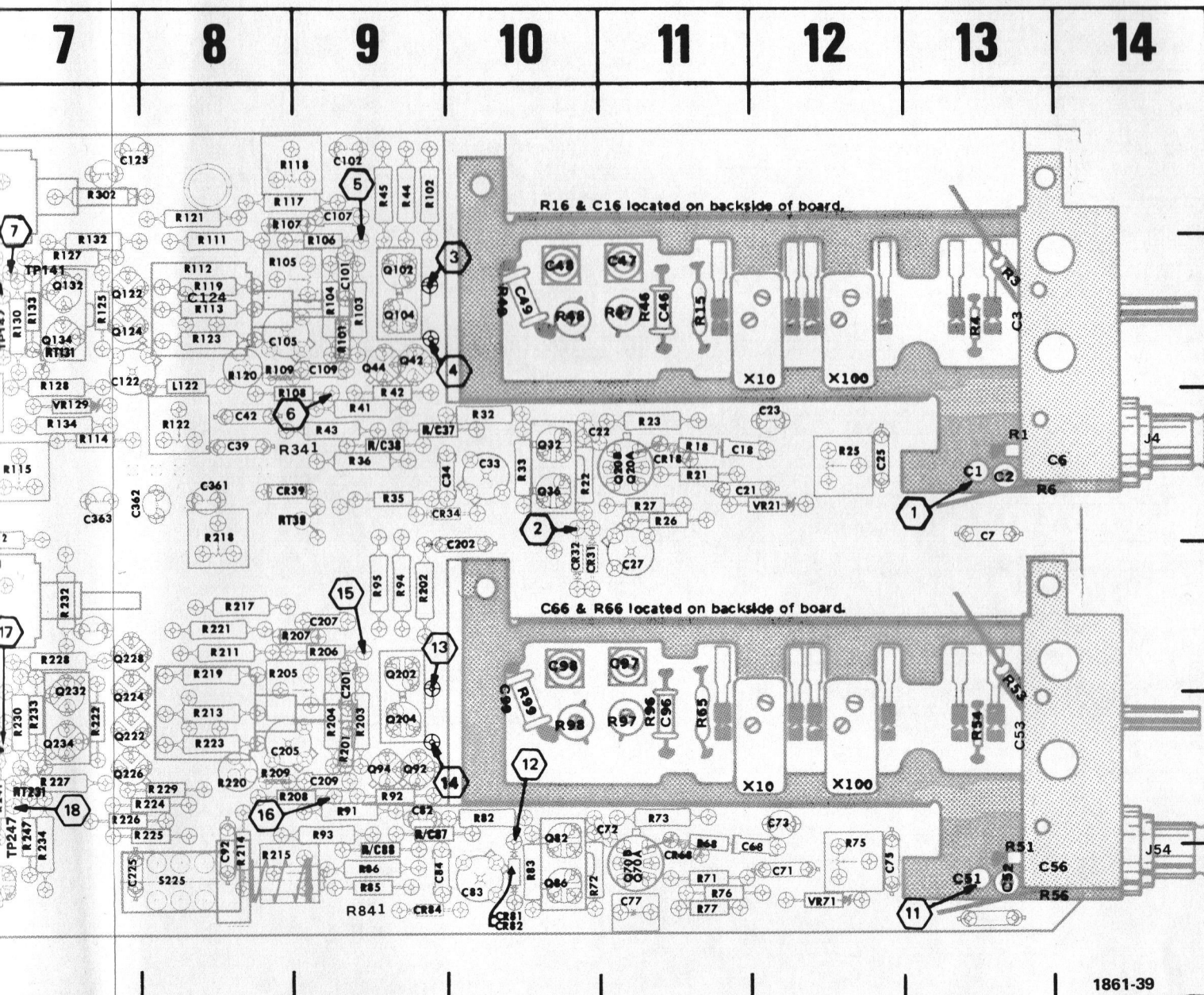

& A2—Attenuators and A3—Vertical Preamp circuit boards.

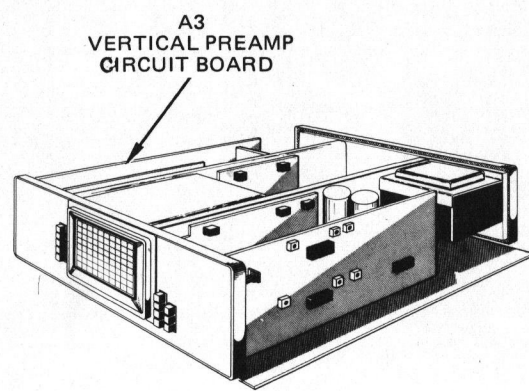

CKT NO	GRID LOC	CKT NO	GRID LOC	CKT NO	GRID LOC	CKT NO	GRID LOC	CKT NO	GRID LOC	CKT NO	GRID LOC		
C1	13C	C201	9D	CR368	3E	Q304	5B	R91	9E	R202	9D	R336	4C
C2	13C	C202	10C	CR372	4D	Q308	6C	R92	9E	R203	9E	R340	2B
C3	13B	C205	8E	CR378	3D	Q314	6D	R93	9E	R205	8D	R341	3C
C6	13C	C207	9D			Q318	5D	R94	9D	R206	9D	R342	4C
C7	13C	C209	9E			Q322	4C	R95	9D	R207	9D	R343	4B
C18	11C	C225	7F			Q324	4D	R96	11E	R208	9E	R344	3B
C21	11C	C229†		J4	14C	Q332	4D	R97	11E	R209	8E	R345	4B
C22	11C	C235	6D	J162	2B	Q344	3B	R98	10E	R211	8D	R346	4B
C23	12C	C237	6E	J164	2A	Q346	3B	R99	10E	R212†		R347	3B
C25	12C	C242	6F	J168	1A	Q352	3E	R101	9B	R213	8E	R348	3B
C27	11D	C245	6E	J262	4F	Q358	2E	R102	9A	R214	8F	R349	3B
C33	10C	C249	6E	J338	2B	Q364	3E	R103	9B	R215	8F	R351	3F
C34	10C	C251	6F	J339	2D	Q374	3D	R104	9E	R217	8D	R352	2E
C36	10C	C253	5E	J351	2F			R105	8B	R219	8D	R356	3E
C37	9C	C261	5E	J359	2F			R106	9B	R220	8E	R357	2E
C38	9C	C262	4F					R107	8A	R221	8D	R358	2D
C39	8C	C302†				R1	13C	R108	8C	R222	7E	R359	2E
C42	8C	C321	5D	L122	8B	R3	13B	R109	8B	R223	8E	R361	2E
C46	11B	C334	3D	L149	6C	R4	13B	R111	8B	R224	8E	R362	4E
C47	11B	C338	3C	L249	5E	R6	13C	R112	8B	R225	8E	R364	3E
C48	10B	C339	3C	L338	4C	R15	11B	R113	8B	R226	7E	R365	2D
C49	10B	C346	3B	L339	4C	R18	11C	R114	7C	R227	7E	R367	4E
C51	13F	C347	4B			R21	11C	R115	7C	R228	7D	R368	2E
C52	13F	C349	3B			R22	10C	R116	7C	R229	8E	R370	3D
C53	13E	C351	3F			R23	11C	R117	8A	R230	7E	R371	2D
C56	13F	C352	4E	Q20A	11C	R25	12C	R119	8E	R232	7D	R372	3D
C57†		C354	3F	Q20B	11C	R26	11C	R120	8B	R234	7F	R374	3E
C68	12F	C356	3E	Q32	10C	R27	11C	R121	8A	R235	6D	R375	2D
C71	12F	C358	2D	Q36	10C	R32	10C	R122	8C	R236	6D	R376	4D
C72	11E	C361	8C	Q42	9B	R33	10C	R123	8B	R237	6E	R378	2E
C73	12E	C362	7C	Q44	9B	R34 ¹	9C	R125	7B	R238	6E		
C75	12F	C363	7C	Q70A	11F	R35	9C	R127	7B	R241	7E		
C77	11F	C364	3E	Q82	10E	R36	9C	R128	7B	R242	6E		
C82	9E	C368	3E	Q86	10F	R37	9C	R130	7B	R243	6E	RT39	9C
C83	10F	C374	3E	Q92	9E	R38	9C	R132	7B	R244	6E	RT231	7E
C84	9F			Q94	9E	R41	9C	R133	7B	R245	6E		
C87	9E	CR18	11C	Q102	9B	R42	9C	R134	7C	R246	6F		
C88	9F	CR31	10D	Q104	9B	R43	9C	R135	6B	R247	7E	S338	2C
C92	8F	CR32	10D	Q122	7B	R44	9A	R136	6B	R249	5D		
C96	11D	CR34	10C	Q124	7B	R45	9A	R137	6B	R251	6F		
C97	11D	CR39	8C	Q132	7B	R46	11B	R138	6B	R252	5F	T354	3E
C98	10D	CR68	11F	Q134	7B	R47	11B	R141	6B	R254	5E		
C99	10D	CR81	10F	Q142	6A	R48	10B	R142	5A	R255	5E		
C101	9B	CR82	10F	Q148	6B	R49	10B	R143	5A	R261	4E	TP322	4C
C102	9A	CR84	9F	Q152	5B	R53	13D	R144	6A	R262	4E	TP324	4C
C105	8B	CR152	4B	Q162	4A	R54	13E	R145	5A			TP346	3B
C107	9A	CR164	4A	Q164	4A	R65	11E	R146	5B	R301	6A	TP364	4E
C109	9B	CR165	5A	Q168	2A	R68	11E	R147	6B	R302	7A	TP374	3D
C122	7B	CR166	5A	Q202	9D	R71	11F	R149	6C	R311	6D		
C124	8B	CR167	5A	Q204	9E	R72	10F	R151	5B	R312	7C	VR21	12C
C125	7A	CR252	5F	Q222	7E	R73	11E	R152	4B	R321	5D	VR71	12F
C135	6B	CR304	5C	Q224	7E	R75	12E	R154	4B	R322	5D	VR129	7C
C137	6B	CR305	6C	Q226	7E	R76	11F	R155	5B	R323	5C	VR229	6D
C142	6A	CR307	5C	Q228	7D	R77	11F	R161	3B	R324	5C		
C144	5A	CR308	5C	Q232	7E	R82	10E	R162	3A	R325	4C		
C149	6C	CR314	5D	Q234	7E	R83	10F	R164	3A	R326	3D		
C151	5B	CR315	6D	Q248	6F	R84 ¹	9F	R165	4A	R327	4D		
C161	3A	CR317	5D	Q252	5F	R85	9F	R168	3A	R331	4C		
C162	3B	CR318	5D	Q262	5E	R86	9F	R169	3B	R332	4D		
C164	4B	CR342	4C			R87	9E			R334	4D		
C165	4A	CR362	4D			R88	9F			R335	4C		

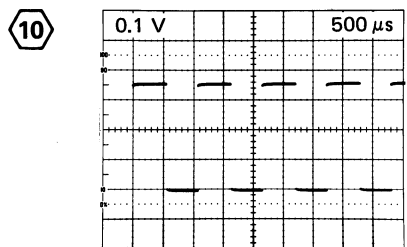
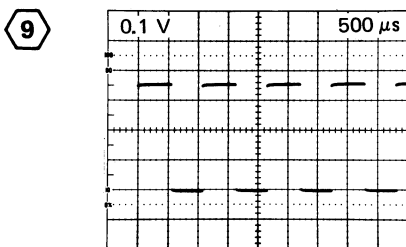
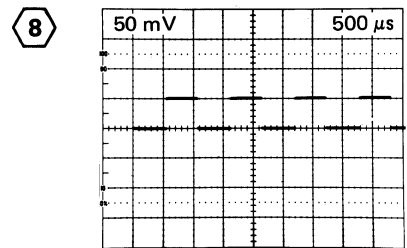
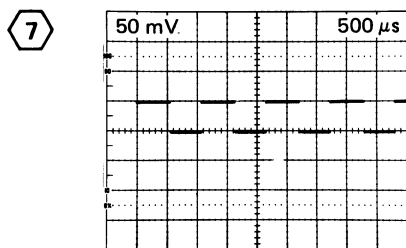
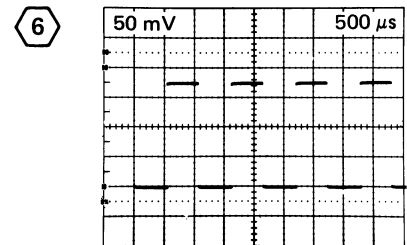
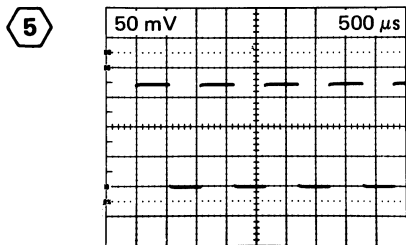
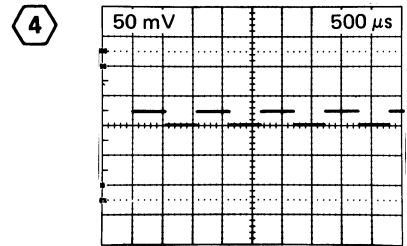
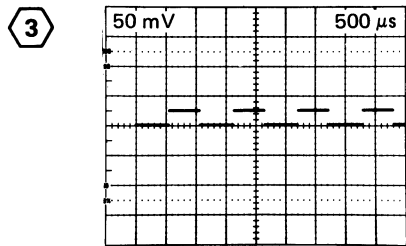
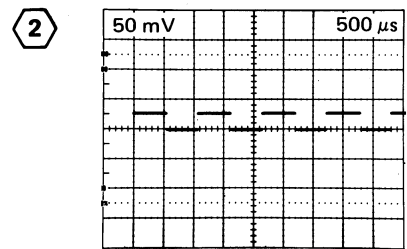
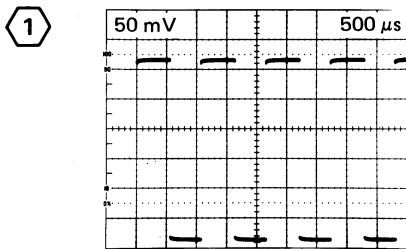

VOLTAGE & WAVEFORM CONDITIONS

(SHOWN IN AC POS)

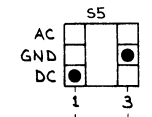

S10 VOLTS/DIV (SHOWN IN 5mV POSITION)

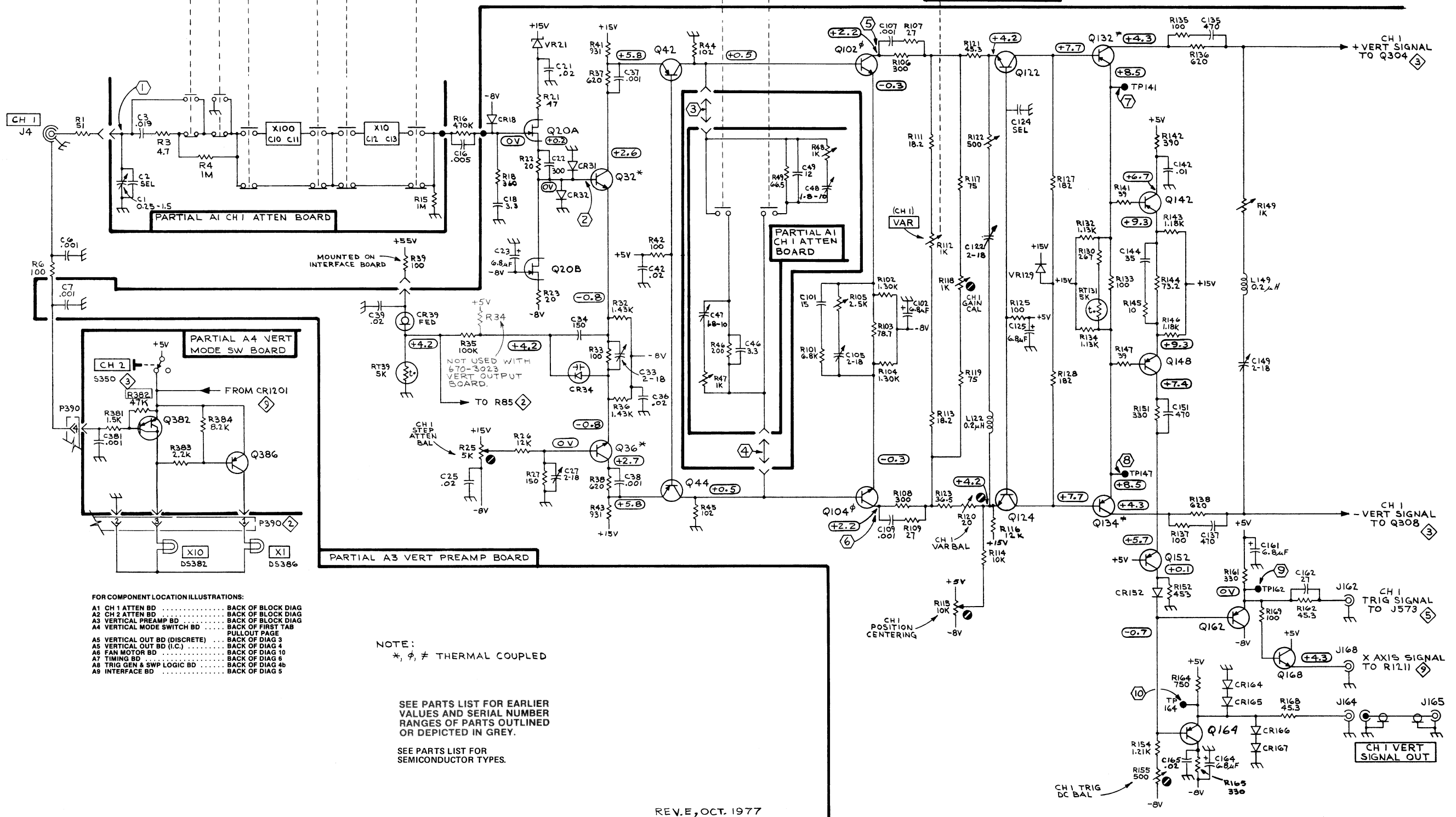
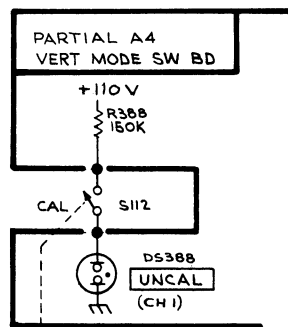
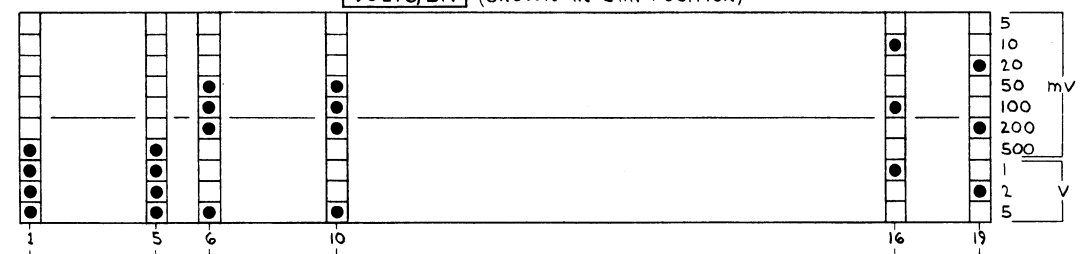

- FOR COMPONENT LOCATION ILLUSTRATIONS:
- A1 CH 1 ATTEN BD BACK OF BLOCK DIAG
 - A2 CH 2 ATTEN BD BACK OF BLOCK DIAG
 - A3 VERTICAL PREAMP BD BACK OF BLOCK DIAG
 - A4 VERTICAL MODE SWITCH BD BACK OF FIRST TAB PULLOUT PAGE
 - A5 VERTICAL OUT BD (DISCRETE) BACK OF DIAG 3
 - A5 VERTICAL OUT BD (I.C.) BACK OF DIAG 4
 - A6 FAN MOTOR BD BACK OF DIAG 10
 - A7 TIMING BD BACK OF DIAG 6
 - A8 TRIG GEN & SWP LOGIC BD BACK OF DIAG 4b
 - A9 INTERFACE BD BACK OF DIAG 5

NOTE:
*, φ, ≠ THERMAL COUPLED

SEE PARTS LIST FOR EARLIER VALUES AND SERIAL NUMBER RANGES OF PARTS OUTLINED OR DEPICTED IN GREY.

SEE PARTS LIST FOR SEMICONDUCTOR TYPES.

REV. E, OCT. 1977
1861-40

CH 1 VERTICAL PREAMP

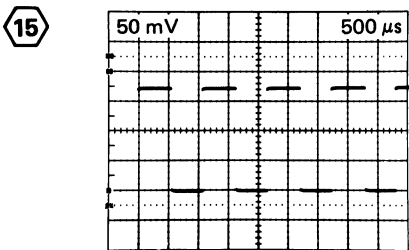
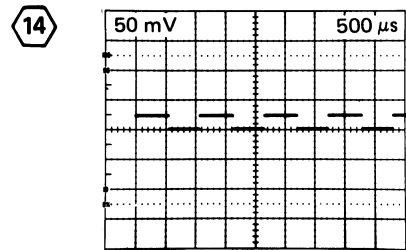
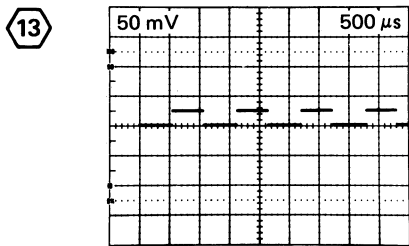
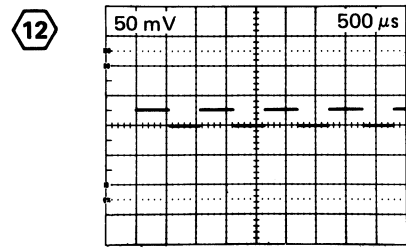
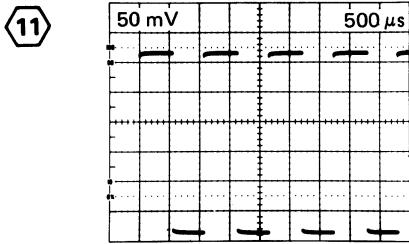

For waveforms 11 through 15. Connect the calibrator signal to the CH 2 input via a X10 probe. Set the VERT MODE switch to CH 2.

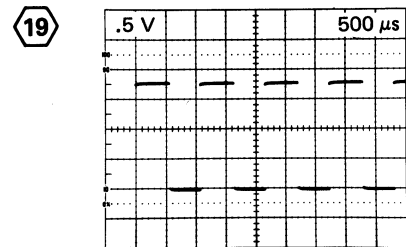
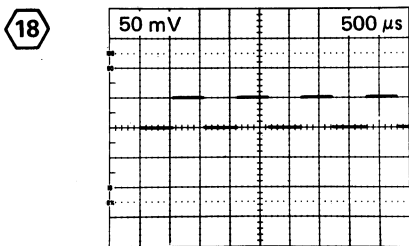
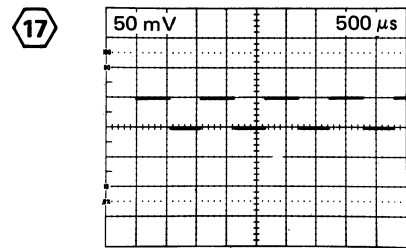
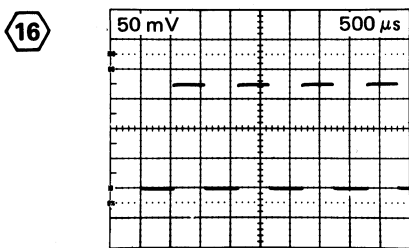

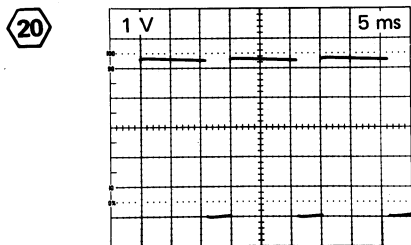

Set DELAY TIME POSITION to 10.0.

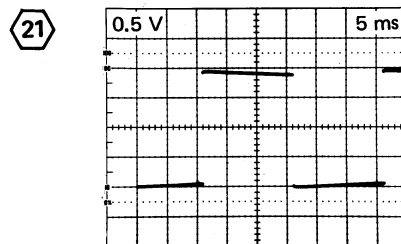

Set the 465 VERT MODE switch to ALT and the A SOURCE switch to CH 1. Set DELAY TIME POSITION to 10.0.

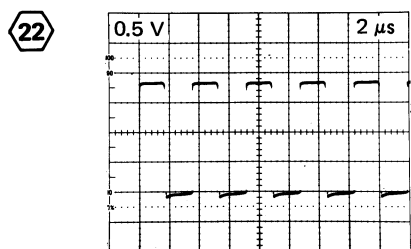

Set the 465 VERT MODE switch to CHOP.
Set the test scope Trigger Source switch to Normal.

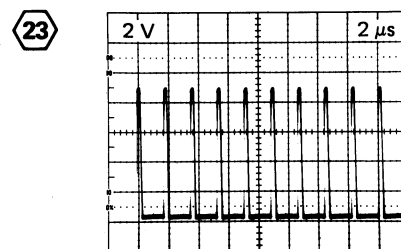

Set the 465 VERT MODE switch to CHOP.
Set the test scope Trigger Source switch to Normal. Pulse rate may vary depending on chop rate of individual instruments.

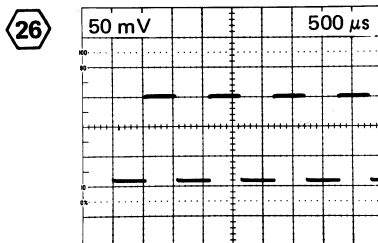
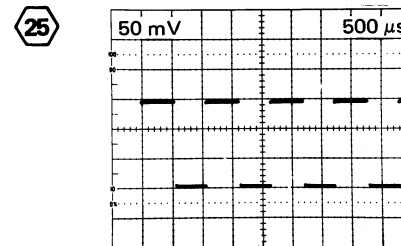
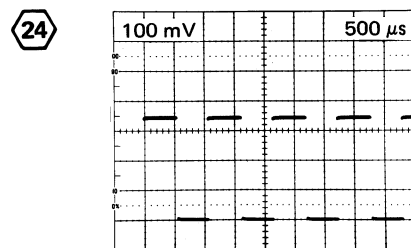

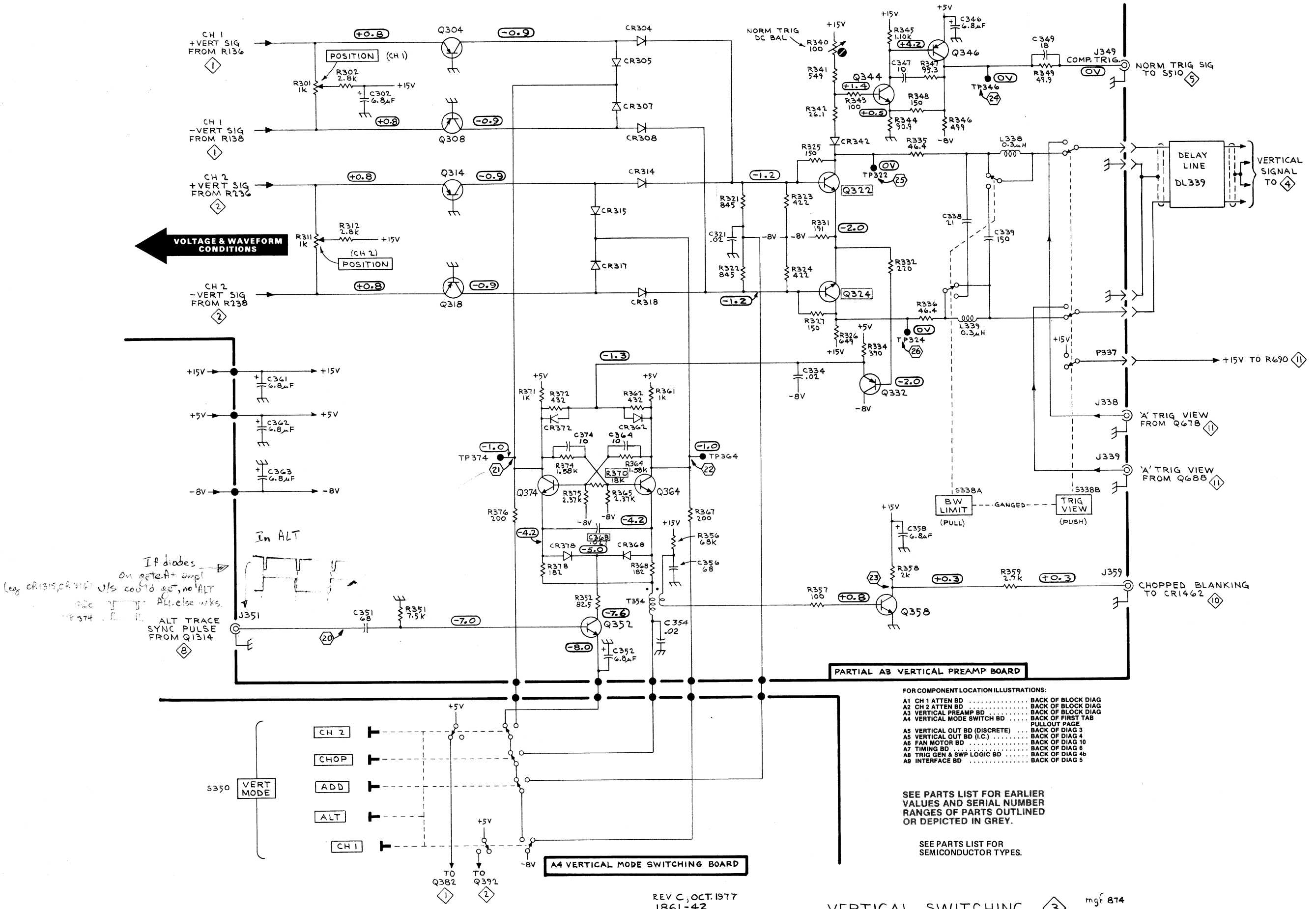

VOLTAGE & WAVEFORM CONDITIONS

If diodes on gate A+ amp (eg CR315, CR316) w/s could get, no ALT. All else wks. TP374.

ALT TRACE SYNC PULSE FROM Q1314

In ALT

- FOR COMPONENT LOCATION ILLUSTRATIONS:
- A1 CH 1 ATTEN BD BACK OF BLOCK DIAG
 - A2 CH 2 ATTEN BD BACK OF BLOCK DIAG
 - A3 VERTICAL PREAMP BD BACK OF BLOCK DIAG
 - A4 VERTICAL MODE SWITCH BD BACK OF FIRST TAB PULLOUT PAGE
 - A5 VERTICAL OUT BD (DISCRETE) BACK OF DIAG 3
 - A5 VERTICAL OUT BD (I.C.) BACK OF DIAG 4
 - A6 FAN MOTOR BD BACK OF DIAG 10
 - A7 TIMING BD BACK OF DIAG 6
 - A8 TRIG GEN & SWP LOGIC BD BACK OF DIAG 4b
 - A9 INTERFACE BD BACK OF DIAG 5

SEE PARTS LIST FOR EARLIER VALUES AND SERIAL NUMBER RANGES OF PARTS OUTLINED OR DEPICTED IN GREY.

SEE PARTS LIST FOR SEMICONDUCTOR TYPES.

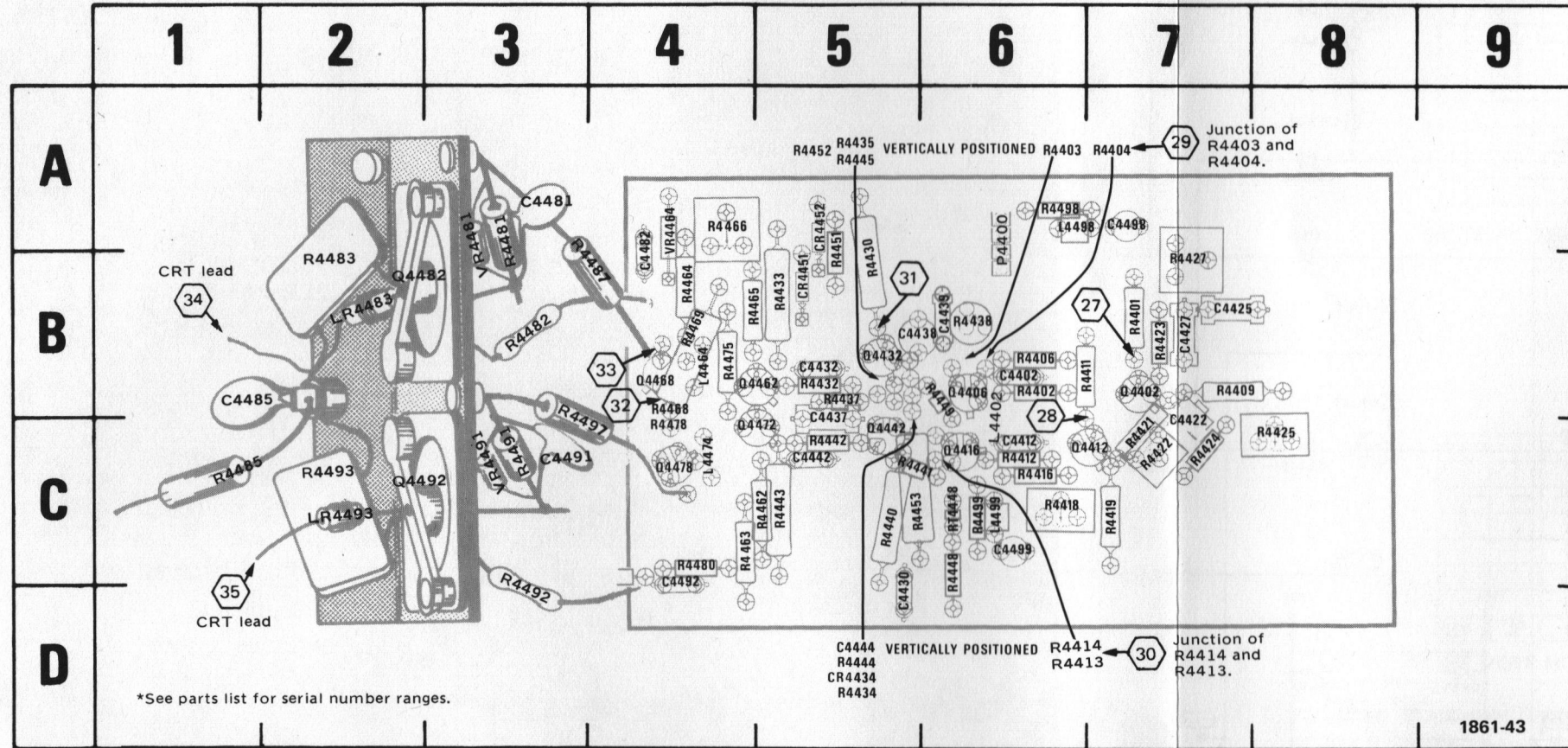
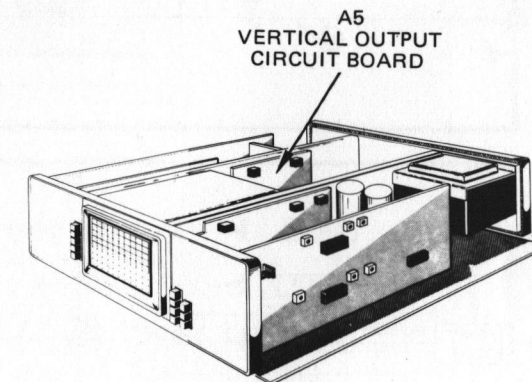

Fig. 8-4. A5a—Vertical Output Amplifier circuit board (discrete version).

†LOCATED ON BACK OF BOARD

CKT NO	GRID LOC	CKT NO	GRID LOC	CKT NO	GRID LOC	CKT NO	GRID LOC	CKT NO	GRID LOC
C4402	6B	L4402	6B	R4401	7B	R4433	5B	R4469	4B
C4412	6C	L4464	4B	R4402	6B	R4434	5D	R4474†	
C4422	7C	L4474	4C	R4403	6A	R4435	5A	R4475	4B
C4425	7B	L4498	6A	R4404	7A	R4436†		R4478	4C
C4427	7B	L4499	6C	R4406	7B	R4437	5B	R4480	4C
C4430	5D			R4408†		R4438	6B	R4481	3A
C4432	5B	LR4483	2B	R4409	7B	R4440	5C	R4482	3B
C4437	5B	LR4493	2C	R4411	6B	R4441	5C	R4483	2A
C4438	5B			R4412	6C	R4442	5C	R4485	1C
C4439	6B	P4400	6A	R4413	6D	R4443	5C	R4487	3B
C4442	5C			R4414	6D	R4444	5D	R4491	3C
C4444	5D	Q4402	7B	R4416	6C	R4445	5A	R4492	3D
C4481	3A	Q4406	6B	R4418	6C	R4448	6C	R4493	2C
C4482	4A	Q4412	6C	R4419	7C	R4449	6B	R4497	3B
C4485	1B	Q4416	6C	R4421	7C	R4451	5B	R4498	6A
C4491	3C	Q4432	5B	R4422	7C	R4452	5A	R4499	6C
C4492	4D	Q4442	5C	R4423	7B	R4453	5C		
C4498	7A	Q4462	4B	R4424	7C	R4462	5C	RT4448	6C
C4499	6C	Q4468	4B	R4425	8C	R4463	4C		
		Q4472	5C	R4427	7B	R4464	4B	VR4464	4A
CR4434	5D	Q4478	4C	R4430	5B	R4465	4B	VR4481	3A
CR4451	5B	Q4482	2B	R4431†		R4466	4A	VR4491	3C
CR4452	5A	Q4492	2C	R4432	5B	R4468	4B		



27

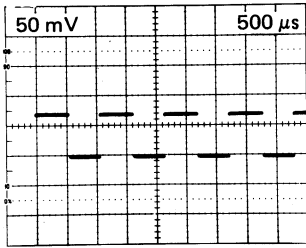

28

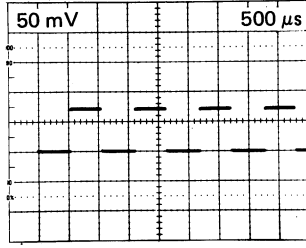

29

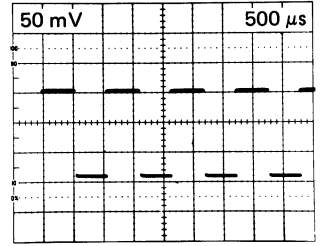

30

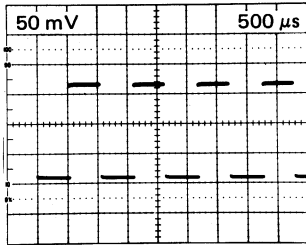

31

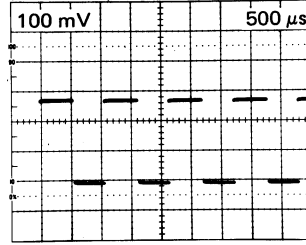

32

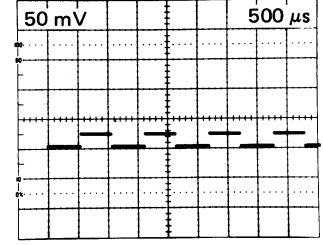

33

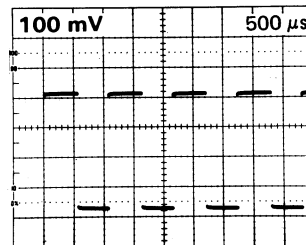

34

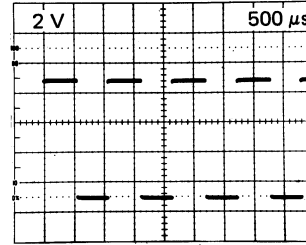

35

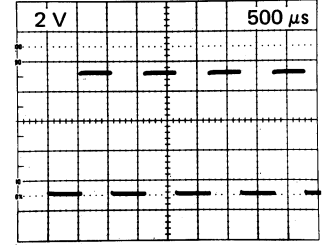

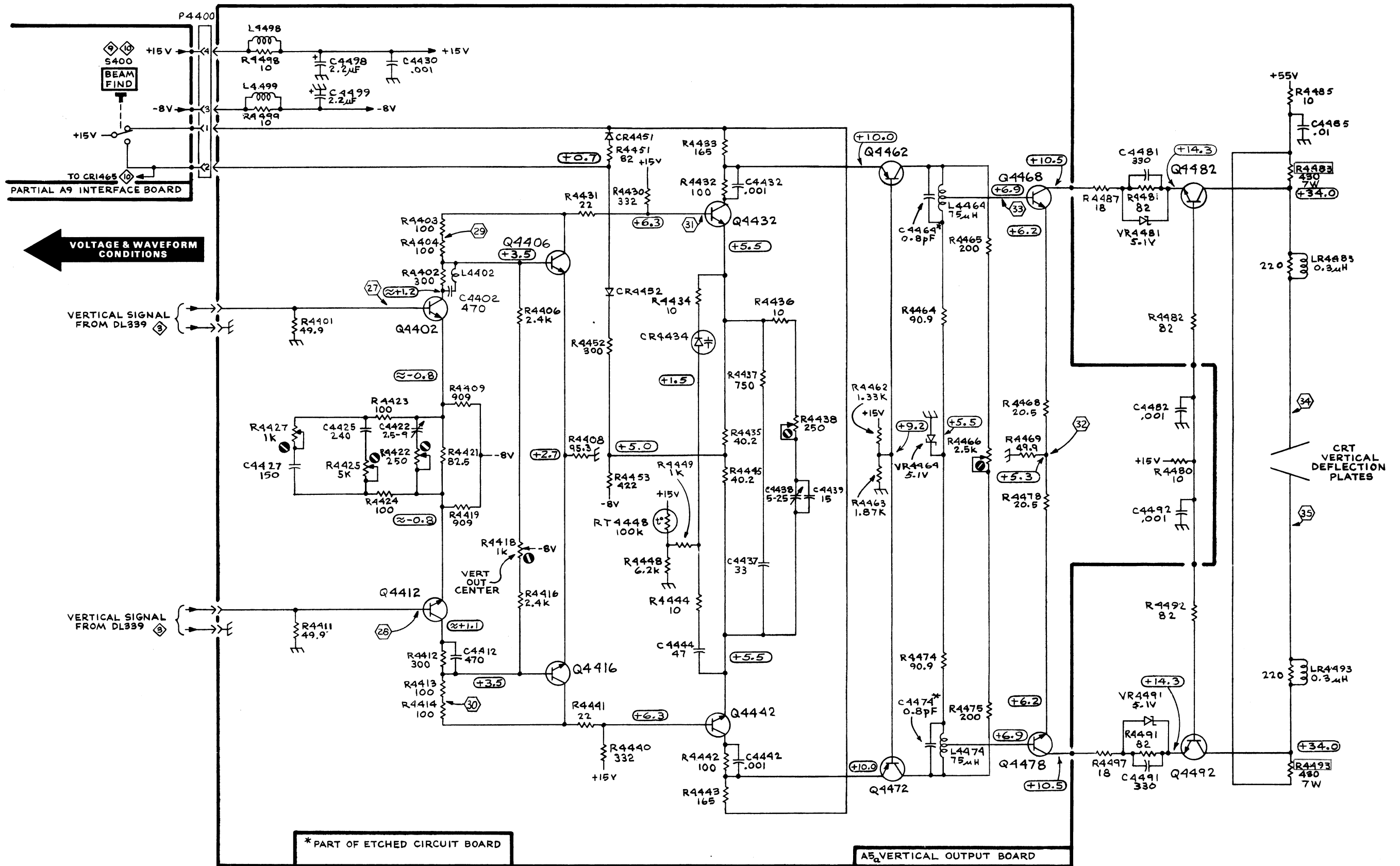

VOLTAGE & WAVEFORM CONDITIONS

VERTICAL SIGNAL FROM DL339

VERTICAL SIGNAL FROM DL339

* PART OF ETCHED CIRCUIT BOARD

A5 VERTICAL OUTPUT BOARD

- FOR COMPONENT LOCATION ILLUSTRATIONS:
- A1 CH 1 ATTEN BD BACK OF BLOCK DIAG
 - A2 CH 2 ATTEN BD BACK OF BLOCK DIAG
 - A3 VERTICAL PREAMP BD BACK OF BLOCK DIAG
 - A4 VERTICAL MODE SWITCH BD BACK OF FIRST TAB
 - PULL OUT PAGE
 - A5 VERTICAL OUT BD (DISCRETE) BACK OF DIAG 3
 - A5 VERTICAL OUT BD (I.C.) BACK OF DIAG 4
 - A6 FAN MOTOR BD BACK OF DIAG 10
 - A7 TIMING BD BACK OF DIAG 6
 - A8 TRIG GEN & SWP LOGIC BD BACK OF DIAG 4b
 - A9 INTERFACE BD BACK OF DIAG 5

SEE PARTS LIST FOR EARLIER VALUES AND SERIAL NUMBER RANGES OF PARTS OUTLINED OR DEPICTED IN GREY.

SEE PARTS LIST FOR SEMICONDUCTOR TYPES.

VERTICAL OUTPUT AMPLIFIER (DISCRETE VERSION) 4a

SN B250000 and up
670-3023-

REV C, OCT. 1977
1861-44

VERTICAL OUTPUT AMPL (DISCRETE VERSION)

4a

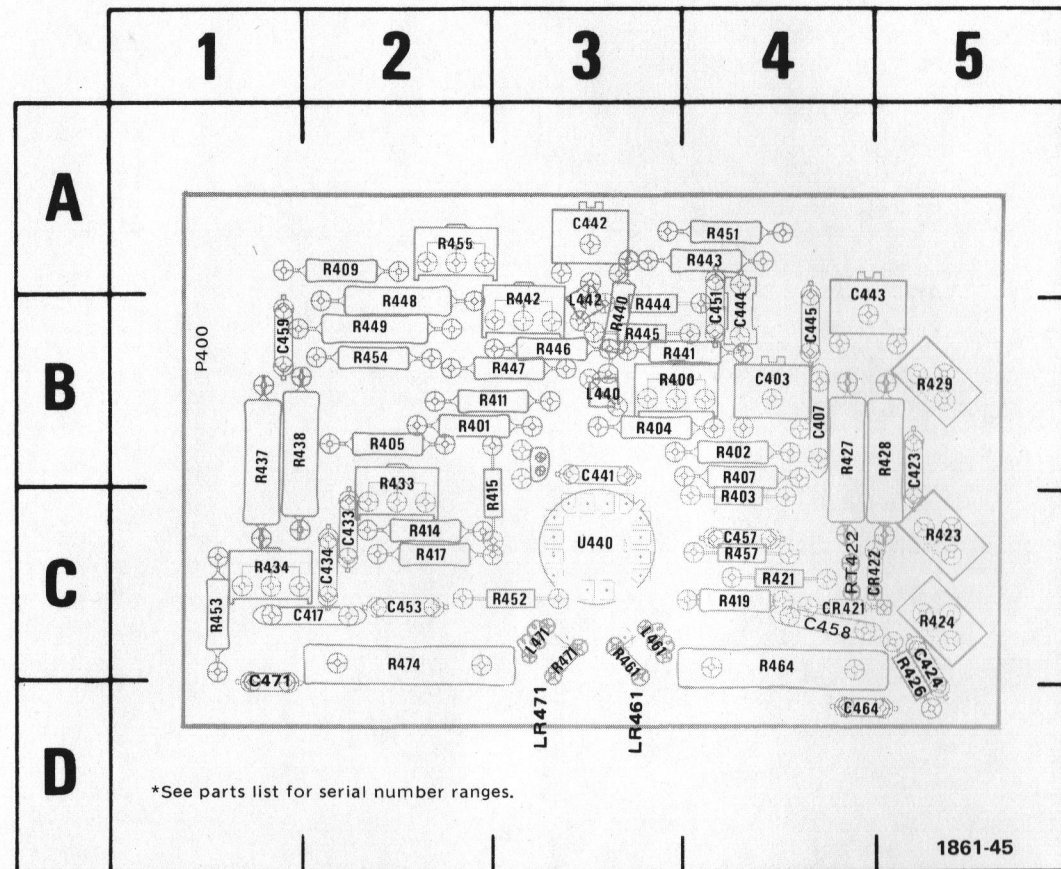
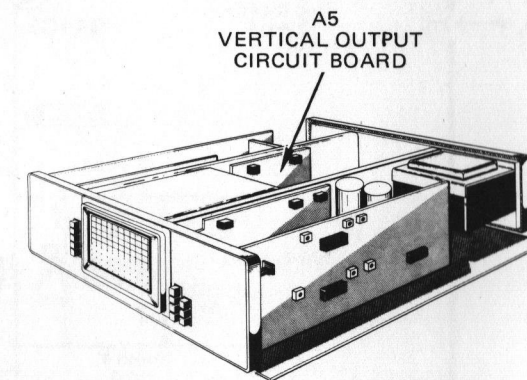
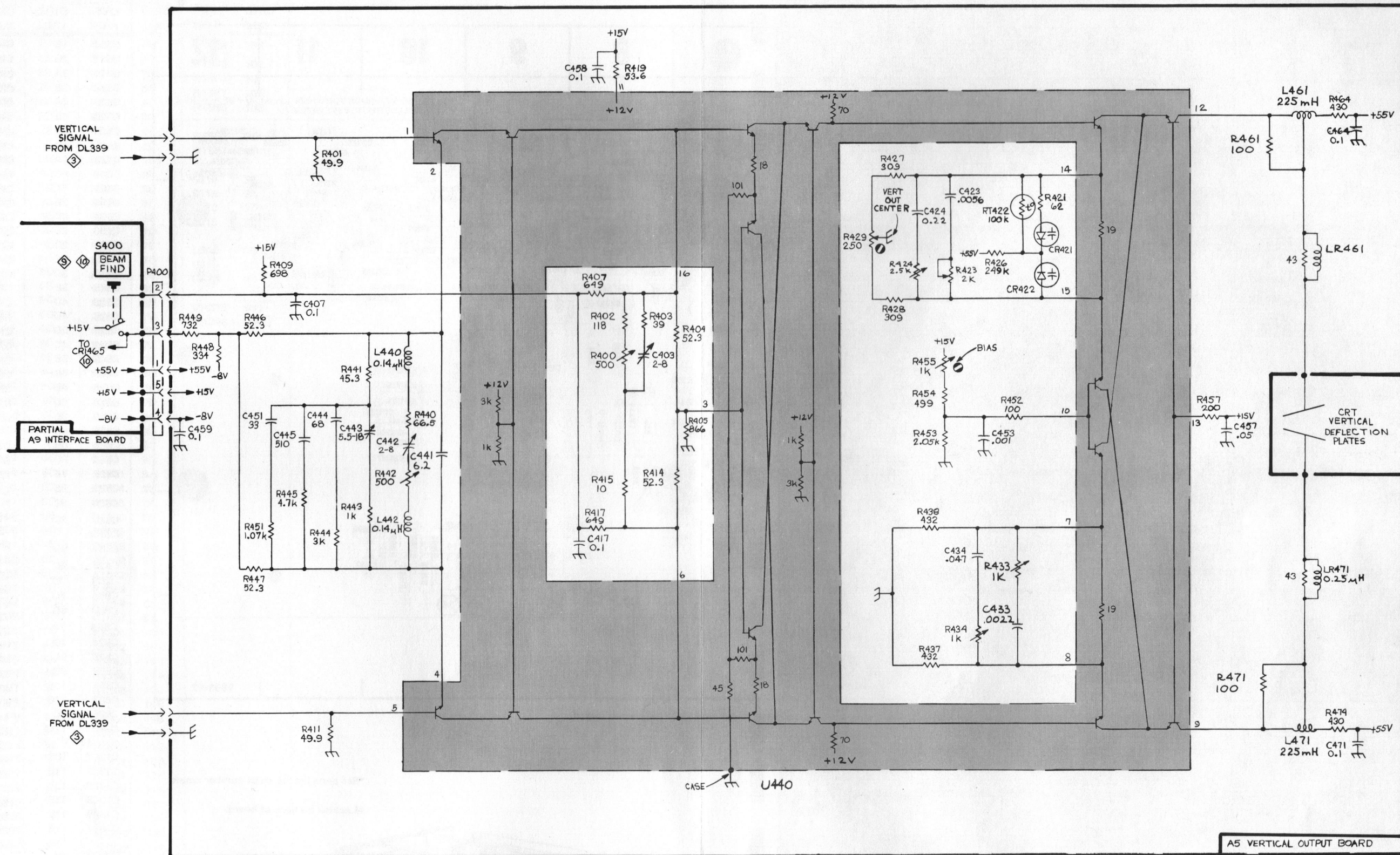

Fig. 8-5. A5b—Vertical Output Amplifier circuit board (IC version).

CKT NO	GRID LOC	CKT NO	GRID LOC	CKT NO	GRID LOC	CKT NO	GRID LOC
C403	4B	CR421	4C	R409	2A	R442	3A
C407	4B	CR422	4C	R411	3B	R443	4A
C417	2C			R414	2C	R444	3B
C423	5B	L440	3B	R415	2C	R445	3B
C424	5C	L442	3A	R417	2C	R446	3B
C433	2C	L461	3C	R419	4C	R447	3B
C434	2C	L471	3C	R421	4C	R448	2A
C441	3B	LR461	3D	R423	5C	R449	2B
C442	3A	LR471	3D	R424	5C	R451	4A
C443	5A			R426	5C	R452	3C
C444	4B	P400	1B	R427	4B	R453	1C
C445	4B			R428	5B	R454	2B
C451	4B	R400	3B	R429	5B	R455	2A
C453	2C	R401	2B	R433	2B	R457	4C
C457	4C	R402	4B	R434	1C	R461	3C
C458	4C	R403	4C	R437	1B	R464	4C
C459	1B	R404	3B	R438	1B	R471	3C
C464	4D	R405	2B	R440	3B	R474	2D
C471	1C	R407	4B	R441	3B	RT422	4C
						U440	3C





FOR COMPONENT LOCATION ILLUSTRATIONS:

A1 CH 1 ATTEN BD	BACK OF BLOCK DIAG
A2 CH 2 ATTEN BD	BACK OF BLOCK DIAG
A3 VERTICAL PREAMP BD	BACK OF BLOCK DIAG
A4 VERTICAL MODE SWITCH BD	BACK OF FIRST TAB
A5 VERTICAL OUT BD (DISCRETE)	PULLOUT PAGE
A5 VERTICAL OUT BD (I.C.)	BACK OF DIAG 3
A6 FAN MOTOR BD	BACK OF DIAG 4
A7 TIMING BD	BACK OF DIAG 10
A8 TRIG GEN & SWP LOGIC BD	BACK OF DIAG 6
A9 INTERFACE BD	BACK OF DIAG 4b

465 OSCILLOSCOPE

REV. A, OCT. 1977
1861-46

VERTICAL OUTPUT AMPLIFIER 4
670-2238- SNB250000 AND UP

VERTICAL OUTPUT AMPL (I.C. VERSION) 4
b

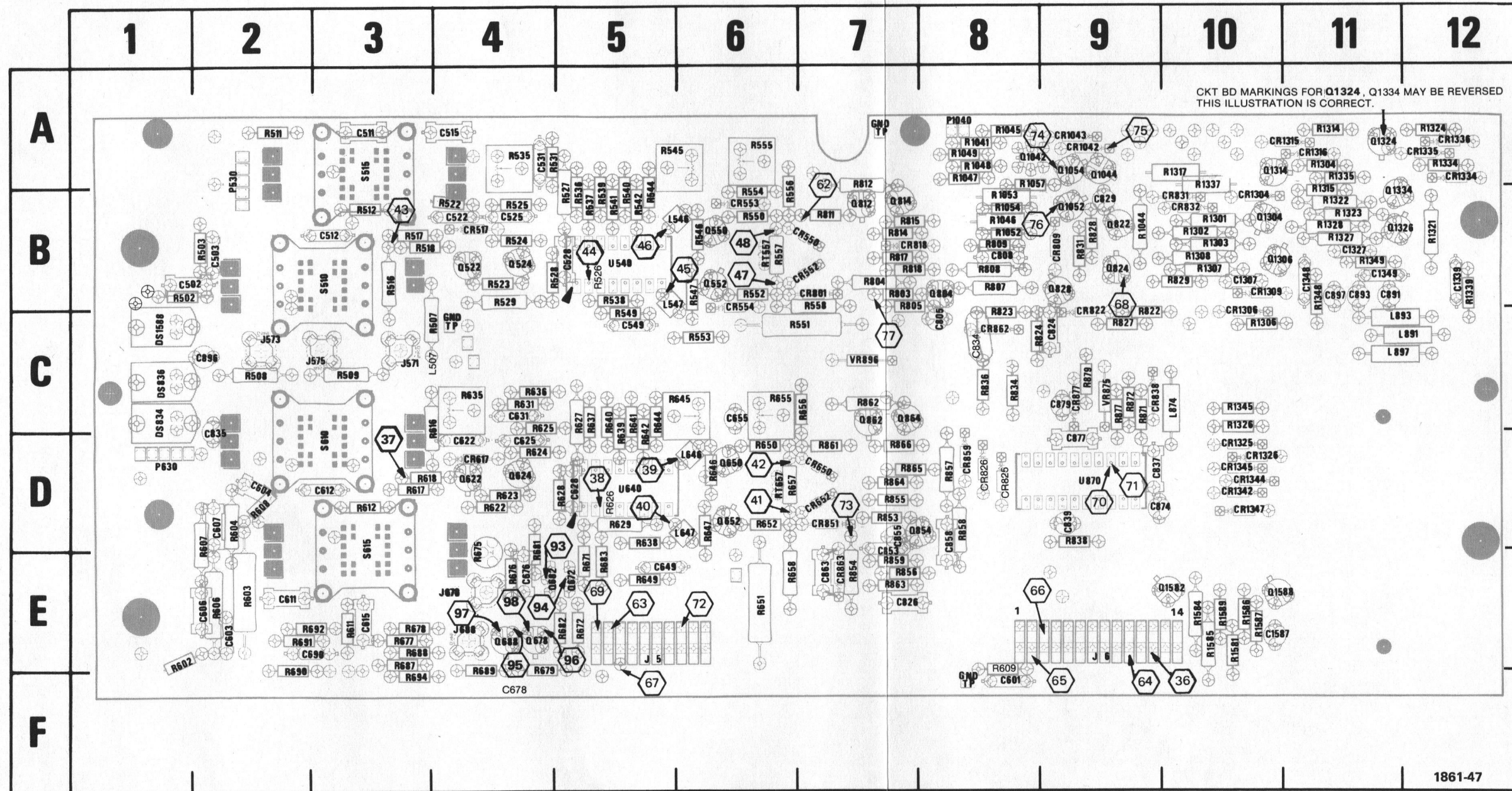
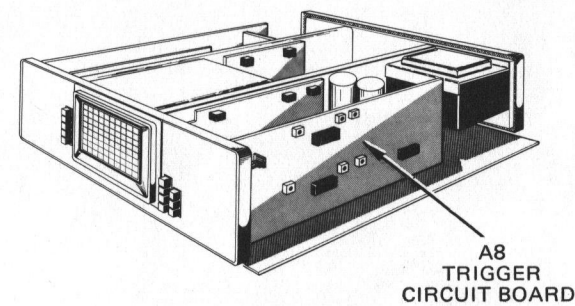

Fig. 8-6. A8—Trigger Generator and Sweep Logic circuit board.

*See parts list for serial number ranges.

†Located on back of board.



CKT NO	GRID LOC	CKT NO	GRID LOC	CKT NO	GRID LOC	CKT NO	GRID LOC
C502	1B	CR809	9B	Q678	4E	R602	
C503	2B	CR818	7B	Q682	4E	R603	
C511	3A	CR822	9B	Q688	4E	R604	
C512	3B	CR831	10B	Q804	8B	R606	
C515	4A	CR832	10B	Q812	7B	R607	
C522	4B	CR838	9C	Q814	7B	R608	
C525	4B	CR851	7D	Q822	9B	R609	
C528	5B	CR859	8D	Q824	9B	R611	
C531	4A	CR862	8C	Q828	9B	R612	
C549	5C	CR863	7E	Q854	8D	R616	
C601	8F	CR877	9C	Q862	7C	R617	
C603	2E	CR1042	9A	Q864	7C	R618	
C604	2D	CR1043	9A	Q1042	8A	R622	
C606	2E	CR1304	10B	Q1044	9A	R623	
C607	2D	CR1306	10B	Q1052	9B	R624	
C611	2E	CR1309	10B	Q1054	9A	R625	
C612	3D	CR1315	11A	Q1304	10B	R626*	
C615	3E	CR1316	11A	Q1306	10B	R627	
C622	4D	CR1325	10D	Q1314	10A	R628	
C625	4D	CR1326	10D	Q1324	11A	R629	
C628	5D	CR1334	12A	Q1326	11B	R631	
C631	4C	CR1335	12A	Q1334	11B	R635	
C649	5E	CR1336	12A	Q1582	10E	R636	
C655	6C	CR1342	10D	Q1588	11E	R637	
C676	4E	CR1344	10D			R638	
C678	9D	CR1345	10D	R502	1B	R639	
C690	3E	CR1347	10D	R503	2B	R640	
C805	8C			R507	4C	R641	
C808	8B	DS834	1C	R508	2C	R642	
C824	9C	DS836	1C	R509	3C	R644	
C826	7E	DS1599	1C	R511	2A	R645	
C829	9B	DS1588	1C	R512	3B	R646	
C834	8C			R516	3B	R647	
C835	2C	J6	9E	R517	3B	R649	
C836†		J571	3C	R518	3B	R650	
C837	9D	J573	2C	R522	4B	R651	
C839	9D	J575	3C	R523	4B	R652	
C853	7D	J678	4E	R524	4B	R655	
C855	7D	J688	4E	R525	4B	R656	
C855	7D	J1317†		R526*	5B	R657	
C858	8D	J1319†		R527	5B	R658	
C863	7E	J1337†		R528	4B	R671	
C874	10D			R529	4B	R672	
C877	9D	L507	4C	R531	4A	R675	
C879	9C	L546	5B	R535	4A	R676	
C891	11B	L547	5B	R536	5B	R677	
C893	11B	L646	6D	R537	5B	R678	
C896	2C	L647	6D	R538	5B	R679	
C897	11B	L874	10C	R539	5B	R681	
C1044†		L891	12C	R540	5B	R682	
C1307	10B	L893	12C	R541	5B	R683	
C1327	11B	L897	12C	R542	5B	R687	
C1339	12B			R544	5B	R688	
C1348	11B	P530	2A	R545	5A	R689	
C1349	11B	P630	1D	R546	6B	R690	
C1587	11E	P1040	8A	R547	6B	R691	
				R549	5C	R692	
CR517	4B	Q522	4B	R550	6B	R694	
CR550	7B	Q524	4B	R551	7C	R803	
CR552	7B	Q550	6B	R552	6B	R804	
CR553	6B	Q552	7B	R553	6C	R805	
CR554	6B	Q622	4D	R554	6B	R807	
CR617	4D	Q624	4D	R555	6A	R808	
CR650	7D	Q650	6D	R556	6B	R809	
CR652	7D	Q652	6D	R557	6B	R811	
CR801	7B	Q672	5E	R558	7B	R812	
				R565	7C	R814	

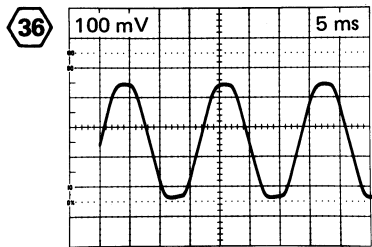

Set Test Oscilloscope A SOURCE to LINE.

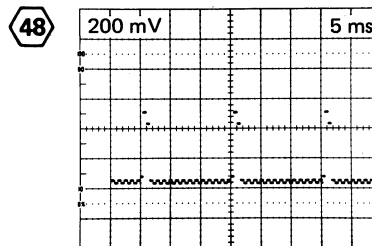
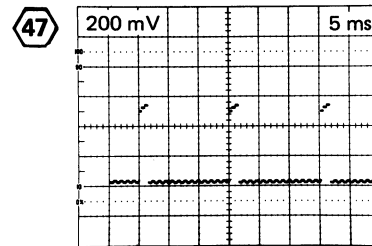
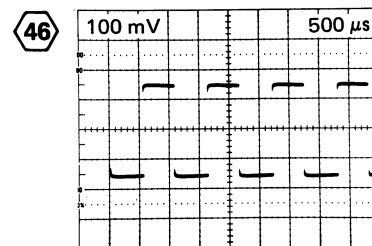
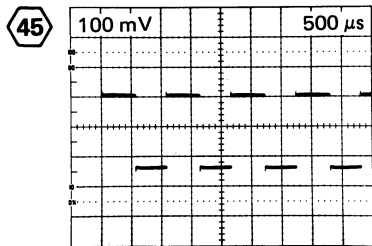
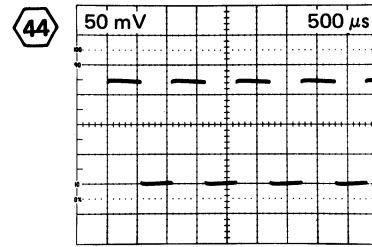
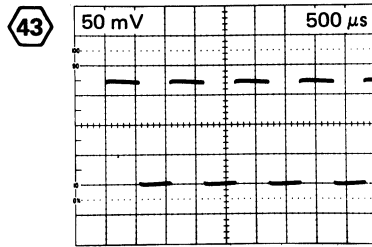
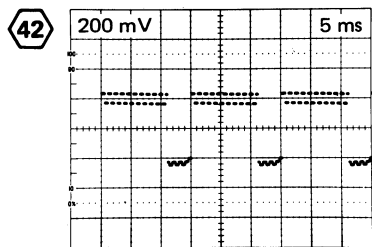
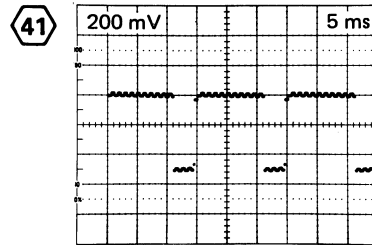
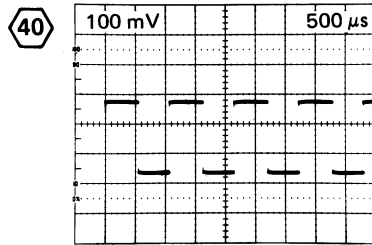
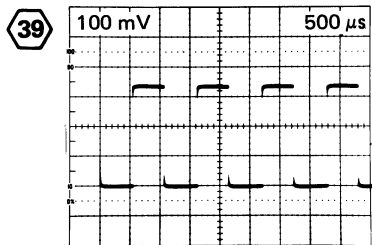
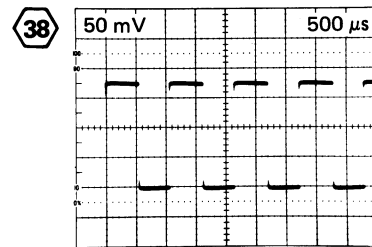
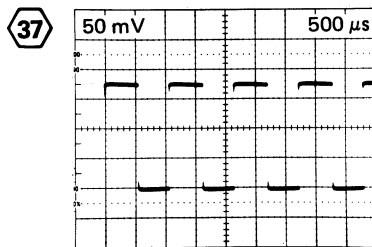

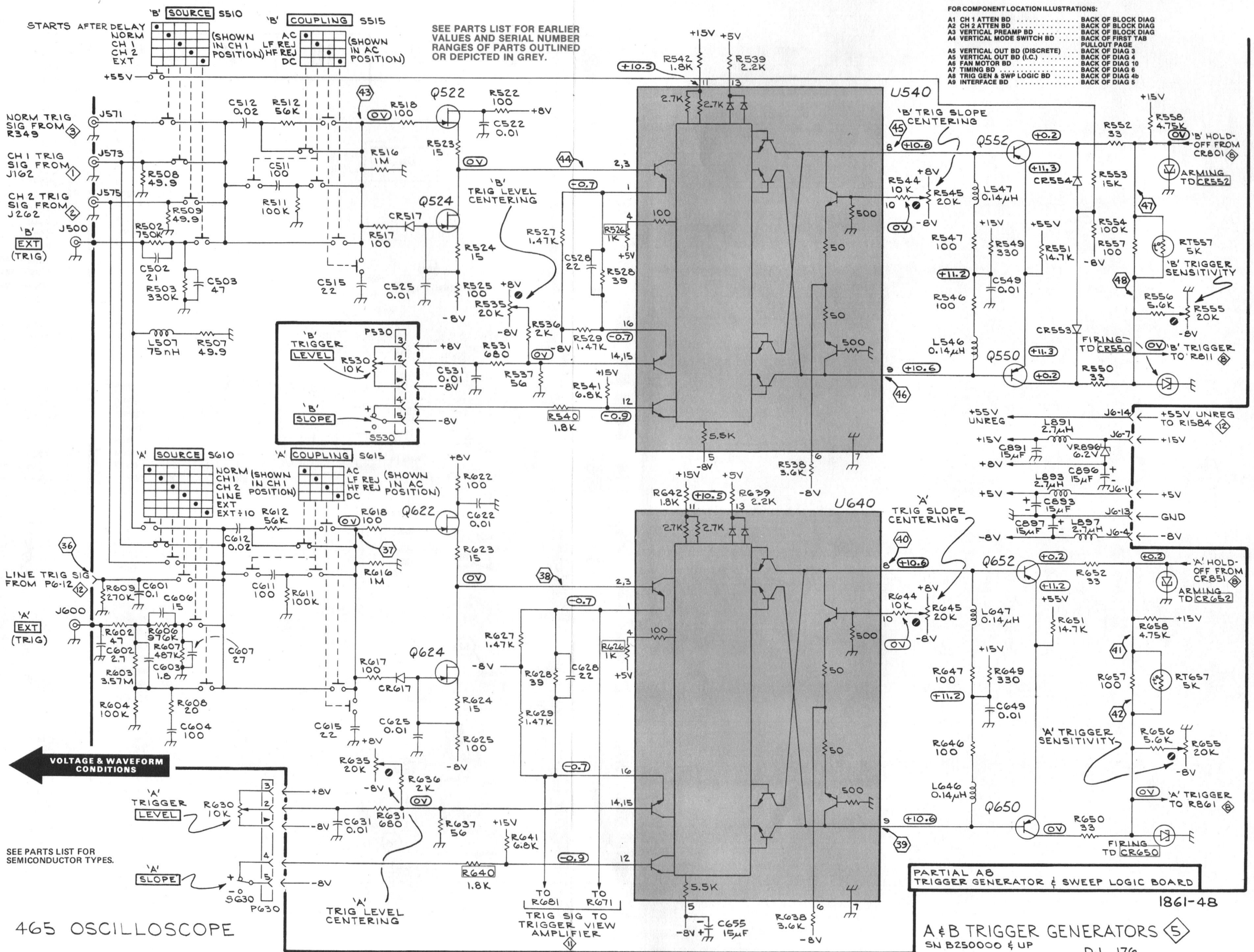

SEE PARTS LIST FOR EARLIER VALUES AND SERIAL NUMBER RANGES OF PARTS OUTLINED OR DEPICTED IN GREY.

VOLTAGE & WAVEFORM CONDITIONS

SEE PARTS LIST FOR SEMICONDUCTOR TYPES.

† Located on back of board
 * See parts list for serial number ranges
 2 Used only with Options 4 and 7
 3 Chassis Mounted

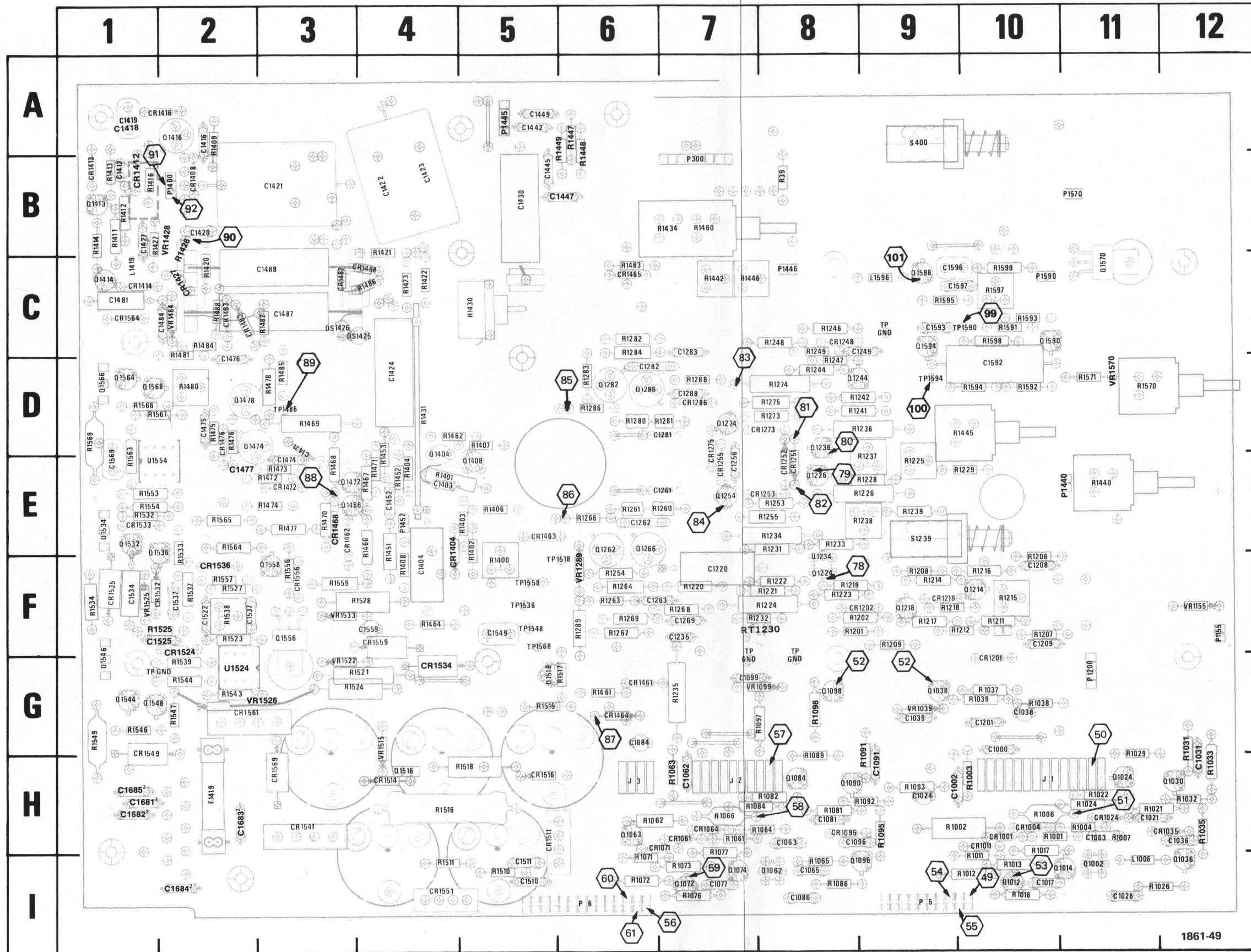

CKT NO	GRID LOC	CKT NO	GRID LOC	CKT NO	GRID LOC	CKT NO	GRID LOC
C1000	10G	C1522	2F	CR1534	4G	Q1404	4D
C1002	9H	C1525	2F	CR1535	1F	Q1408	5E
C1003	11H	C1534	1F	CR1536	2F	Q1413	1B
C1017	10I	C1537	2F	CR1541	3H	Q1414	1C
C1021	11H	C1542†		CR1549	1G	Q1416	2A
C1024	9H	C1549	5F	CR1551	4I	Q1418 ³	
C1026	11I	C1552†		CR1556	3F	Q1466	3E
C1031	12H	C1559	4F	CR1559	4F	Q1472	3E
C1036	12H	C1562†		CR1561	2G	Q1474	2D
C1038	10G	C1569	1E	CR1564	1C	Q1478	2D
C1039	9G	C1592	10D	CR1569	3H	Q1516	4H
C1062	7H	C1593	9C			Q1518	5G
C1063	8H	C1596	9C	DS1425	3C	Q1532	1E
C1065	8I	C1597	9C	DS1426	3C	Q1534	1E
C1077	7I	C16812	1H			Q1536	2E
C1081	8H	C16822	1H	F1419	2H	Q1544	1G
C1084	6G	C16832	2H			Q1546	1F
C1086	8I	C16842	2I	J1	10H	Q1548	1G
C1091	9H	C16852	1H	J2	7H	Q1556	3F
C1096	8H			J3	6H	Q1558	3F
C1099	7G	CR1001	10H			Q1564	1D
C1201	10G	CR1004	10H	L1006	11I	Q1566	1D
C1208	10F	CR1011	10H	L1419	1C	Q1568	1D
C1209	10F	CR1024	11H	L1596	9C	Q1570	11C
C1220	7F	CR1035	12H			Q1590	10C
C1235	7F	CR1061	7H	P5	9I	Q1594	9C
C1249	9C	CR1064	7H	P6	6I	Q1598	9C
C1256	7E	CR1071	7H	P300	7B		
C1261	7E	CR1095	8H	P1155	12F	R39	8B
C1262	6E	CR1201	10G	P1200	11G	R1001	10H
C1263	6F	CR1202	8F	P1400	2B	R1002	9H
C1269	7F	CR1218	9F	P1440	11E	R1003	10H
C1281	7D	CR1248	8C	P1445	5A	R1004	11H
C1282	6D	CR1251	8E	P1446	8C	R1006	10H
C1283	7C	CR1252	8E	P1452	4E	R1007	11H
C1288	7D	CR1253	8E	P1570	11B	R1011	10I
C1403	4E	CR1255	7E	P1590	10C	R1012	10I
C1404	4F	CR1273	8D			R1013	10I
C1412	1B	CR1275	7E	Q1002	11I	R1016	10I
C1416	2A	CR1286	7D	Q1012	10I	R1017	10H
C1418*	1A	CR1404	4E	Q1014	11I	R1021	11H
C1419	1A	CR1408	2B	Q1024	11H	R1022	11H
C1420	2B	CR1412	1B	Q1030	12H	R1024	11H
C1421	3B	CR1413	1B	Q1036	12I	R1026	11I
C1422	4B	CR1414	1C	Q1038	9G	R1029	11H
C1423	4B	CR1416	2A	Q1062	8I	R1031	12H
C1424	4D	CR1421†		Q1063	6H	R1032	12H
C1427	1B	CR1427	2C	Q1072	7I	R1033	12H
C1430	5B	CR1461	6G	Q1074	7I	R1035	12H
C1442	5A	CR1462	3E	Q1084	8H	R1037	10G
C1445	5B	CR1463	5E	Q1090	8H	R1038	10G
C1447	6B	CR1464	6G	Q1096	9I	R1039	10G
C1449	5A	CR1465	6C	Q1098	8G	R1061	7H
C1452	4E	CR1468	3E	Q1214	9F	R1062	6H
C1471	3D	CR1472	3E	Q1218	9F	R1063	7H
C1474	3E	CR1476	2D	Q1224	8F	R1064	8H
C1475	2D	CR1482	2C	Q1226	8E	R1065	8I
C1476	2D	CR1483	2C	Q1234	8F	R1066	7H
C1477	2D	CR1487	3C	Q1236	8D	R1071	6I
C1481	1C	CR1488	4C	Q1244	8D	R1072	6I
C1484	2C	CR1511	5H	Q1254	7E	R1073	7I
C1487	3C	CR1514	4H	Q1262	6E	R1076	7I
C1488	3C	CR1516	5H	Q1266	6E	R1077	7H
C1510	5I	CR1524	2F	Q1274	7D	R1081	8H
C1511	5I	CR1532	2F	Q1282	6D	R1082	8H
C1512†		CR1533	1E	Q1286	6D	R1084	8H
C1513†							

Fig. 8-7. A9—Interface circuit board.

† Located on back of board
 * See parts list for serial number ranges
 † Used only with Options 4 and 7
 ‡ Chassis Mounted

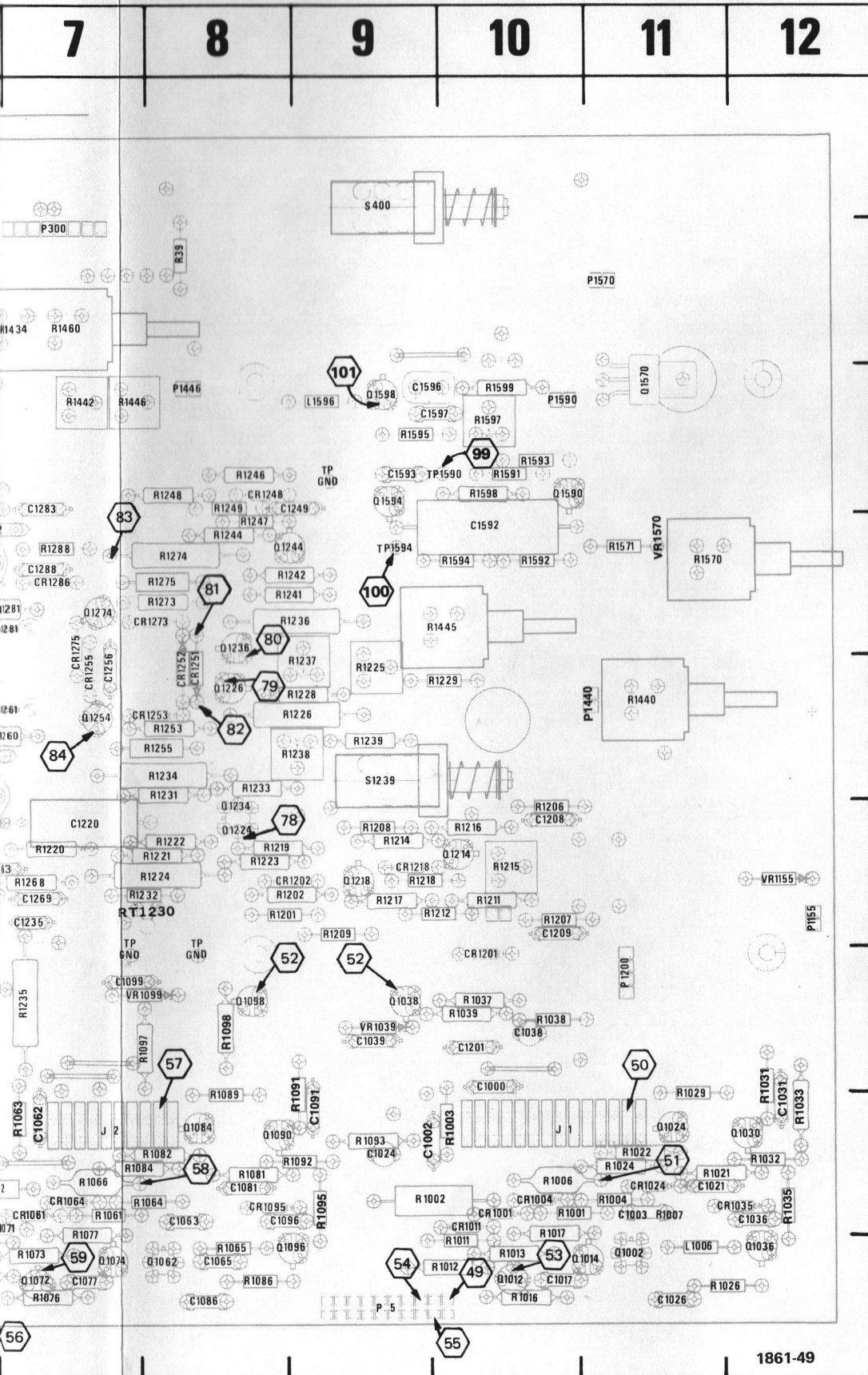

CKT NO	GRID LOC	CKT NO	GRID LOC	CKT NO	GRID LOC	CKT NO	GRID LOC	CKT NO	GRID LOC	CKT NO	GRID LOC	CKT NO	GRID LOC
C1000	10G	C1522	2F	CR1534	4G	Q1404	4D	R1086	8I	R1284	6C	R1519	5G
C1002	9H	C1525	2F	CR1535	1F	Q1408	5E	R1089	8H	R1286	6D	R1521	4G
C1003	11H	C1534	1F	CR1536	2F	Q1413	1B	R1091	9H	R1288	7D	R1523	2F
C1017	10I	C1537	2F	CR1541	3H	Q1414	1C	R1092	9H	R1289	6F	R1524	4G
C1021	11H	C1542†		CR1549	1G	Q1416	2A	R1093	9H	R1400	5F	R1525	2F
C1024	9H	C1549	5F	CR1551	4I	Q1418‡		R1095	9H	R1401	4E	R1527	2F
C1026	11I	C1552†		CR1556	3F	Q1466	3E	R1097	8G	R1402	5E	R1528	4F
C1031	12H	C1559	4F	CR1559	4F	Q1472	3E	R1098	8G	R1403	5E	R1532	1E
C1036	12H	C1562†		CR1561	2G	Q1474	2D	R1201	8F	R1404	4E	R1533	2E
C1038	10G	C1569	1E	CR1564	1C	Q1478	2D	R1202	8F	R1406	5E	R1534	1F
C1039	9G	C1592	10D	CR1569	3H	Q1516	4H	R1206	10F	R1407	5D	R1537	2F
C1062	7H	C1593	9C			Q1518	5G	R1207	10F	R1408	4F	R1538	2F
C1063	8H	C1596	9C	DS1425	3C	Q1532	1E	R1208	9F	R1409	2A	R1539	2G
C1065	8I	C1597	9C	DS1426	3C	Q1534	1E	R1209	9F	R1411	1B	R1543	2G
C1077	7I	C16812	1H			Q1536	2E	R1211	10F	R1412	1B	R1544	2G
C1081	8H	C16822	1H	F1419	2H	Q1544	1G	R1212	10F	R1413	1B	R1546	1G
C1084	6G	C16832	2H			Q1546	1F	R1215	10F	R1414	1B	R1547	2G
C1086	8I	C16842	2I	J1	10H	Q1548	1G	R1216	10F	R1416	1B	R1549	1G
C1091	9H	C16852	1H	J2	7H	Q1556	3F	R1217	9F	R1420	2C	R1553	1E
C1096	8H			J3	6H	Q1558	3F	R1218	9F	R1421	4B	R1554	1E
C1099	7G					Q1564	1D	R1219	8F	R1422	4C	R1556	3F
C1201	10G	CR1001	10H			Q1566	1D	R1220	7F	R1423	4C	R1557	2F
C1208	10F	CR1004	10H	L1006	11I	Q1568	1D	R1221	8F	R1427	1B	R1559	3F
C1209	10F	CR1011	10H	L1419	1C	Q1570	11C	R1222	8F	R1428	2B	R1563	1E
C1220	7F	CR1024	11H	L1596	9C	Q1590	10C	R1223	8F	R1430	5C	R1564	2E
C1235	7F	CR1035	12H			Q1594	9C	R1224	8F	R1431	4D	R1565	2E
C1249	9C	CR1061	7H	P5	9I	Q1598	9C	R1225	9E	R1434	7B	R1566	1D
C1256	7E	CR1064	7H	P6	6I			R1226	9E	R1440	11E	R1567	1D
C1261	7E	CR1071	7H	P300	7B			R1228	9E	R1442	7C	R1569	1D
C1262	6E	CR1077	7H	P1155	12F	R39	8B	R1229	9E	R1445	10D	R1570	11D
C1263	6F	CR1201	10G	P1200	11G	R1001	10H	R1231	8E	R1446	7C	R1571	11D
C1269	7F	CR1202	8F	P1400	2B	R1002	9H	R1232	8F	R1447	6A	R1591	10C
C1281	7D	CR1218	9F	P1440	11E	R1003	10H	R1233	8F	R1448	6A	R1592	10D
C1282	6D	CR1248	8C	P1445	5A	R1004	11H	R1234	8E	R1449	6A	R1593	10C
C1283	7C	CR1251	8E	P1446	8C	R1006	10H	R1234	8E	R1451	4E	R1594	10D
C1288	7D	CR1252	8E	P1452	4E	R1007	11H	R1235	7G	R1452	4E	R1595	9C
C1403	4E	CR1253	8E	P1570	11B	R1011	10I	R1236	8D	R1453	4E	R1597	10C
C1404	4F	CR1255	7E	P1590	10C	R1012	10I	R1237	9E	R1460	7B	R1598	10C
C1412	1B	CR1273	8D			R1013	10I	R1238	9E	R1461	6G	R1599	10C
C1416	2A	CR1275	7E	Q1002	11I	R1016	10I	R1239	9E	R1462	4D	RT1230	8F
C1418*	1A	CR1286	7D	Q1012	10I	R1017	10H	R1241	8D	R1463	6C	S400	9A
C1419	1A	CR1404	4E	Q1014	11I	R1021	11H	R1242	8D	R1464	4F	S1239	9E
C1420	2B	CR1408	2B	Q1024	11H	R1022	11H	R1244	8D	R1466	4E	T1420†	
C1421	3B	CR1412	1B	Q1030	12H	R1024	11H	R1246	8C	R1467	4E	TP1486	3D
C1422	4B	CR1413	1B	Q1036	12I	R1026	11I	R1247	8D	R1468	3E	TP1518	6F
C1423	4B	CR1414	1C	Q1038	9G	R1029	11H	R1248	8D	R1469	3D	TP1536	5F
C1424	4D	CR1416	2A	Q1062	8I	R1031	12H	R1249	8C	R1470	3E	TP1548	5F
C1427	1B	CR1421†		Q1063	6H	R1032	12H	R1253	8E	R1471	4E	TP1558	5F
C1430	5B	CR1427	2C	Q1072	7I	R1033	12H	R1254	6F	R1472	3E	TP1568	5F
C1442	5A	CR1461	6G	Q1074	7I	R1035	12H	R1255	8E	R1473	3E	TP1590	10C
C1445	5B	CR1462	3E	Q1084	8H	R1037	10G	R1260	7E	R1474	3E	TP1594	9D
C1447	6B	CR1463	5E	Q1090	8H	R1038	10G	R1261	6E	R1475	2D		
C1449	5A	CR1464	6G	Q1096	9I	R1039	10G	R1262	6F	R1476	2D	U1432†	
C1452	4E	CR1465	6C	Q1098	8G	R1061	7H	R1263	6F	R1477	3E	U1524	2G
C1471	3D	CR1468	3E	Q1214	9F	R1062	6H	R1264	6F	R1478	3D	U1554	1E
C1474	3E	CR1472	3E	Q1218	9F	R1063	7H	R1266	6E	R1480	2D		
C1475	2D	CR1476	2D	Q1224	8F	R1064	8H	R1268	7F	R1481	2C	VR1039	9G
C1476	2D	CR1482	2C	Q1226	8E	R1065	8I	R1269	6F	R1482	3C	VR1099	7G
C1477	2D	CR1483	2C	Q1234	8F	R1066	7H	R1273	8D	R1484	2C	VR1155	12F
C1481	1C	CR1487	3C	Q1236	8D	R1071	6I	R1274	8D	R1485	3D	VR1289	6F
C1484	2C	CR1488	4C	Q1244	8D	R1072	6I	R1275	8D	R1486	4C	VR1428	2B
C1487	3C	CR1511	5H	Q1254	7E	R1073	7I	R1280	6D	R1488	2C	VR1484	2C
C1488	3C	CR1514	4H	Q1262	6E	R1076	7I	R1281	7D	R1510	5I	VR1515	4G
C1510	5I	CR1516	5H	Q1266	6E	R1077	7H	R1282	6C	R1511	4I	VR1522	3G
C1511	5I	CR1524	2F	Q1274	7D	R1081	8H	R1283	6D	R1516	4H	VR1525	1F
C1512†		CR1532	2F	Q1282	6D	R1082	8H			R1517	6G	VR1526	2G
C1513†		CR1533	1E	Q1286	6D	R1084	8H			R1518	5H	VR1533	3F
												VR1570	11C

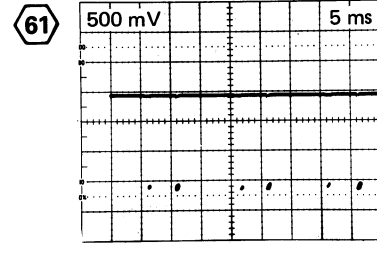
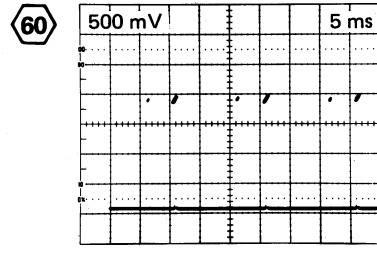
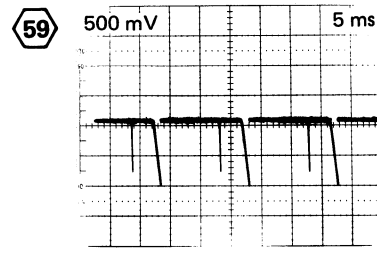
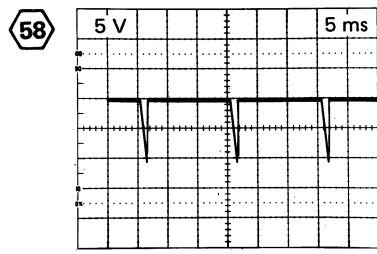
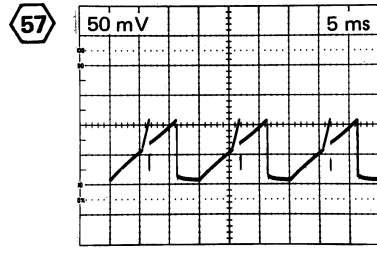
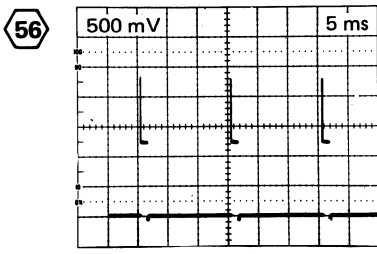
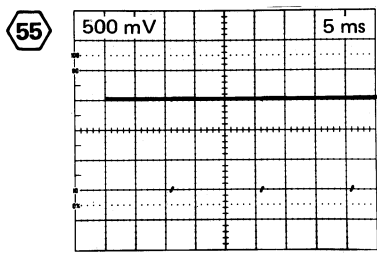
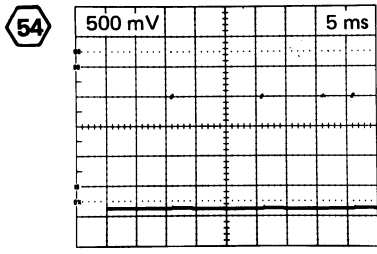
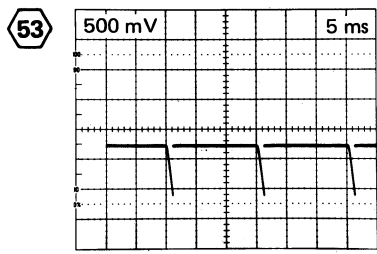
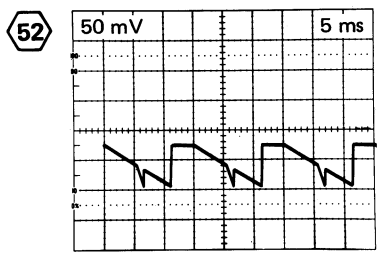
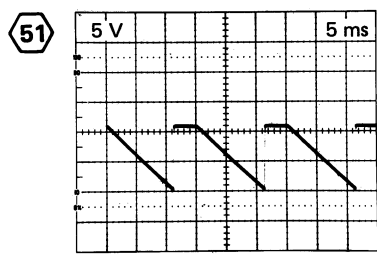
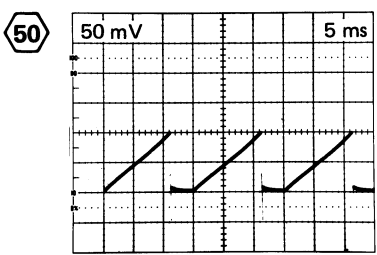
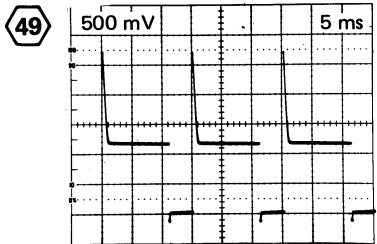

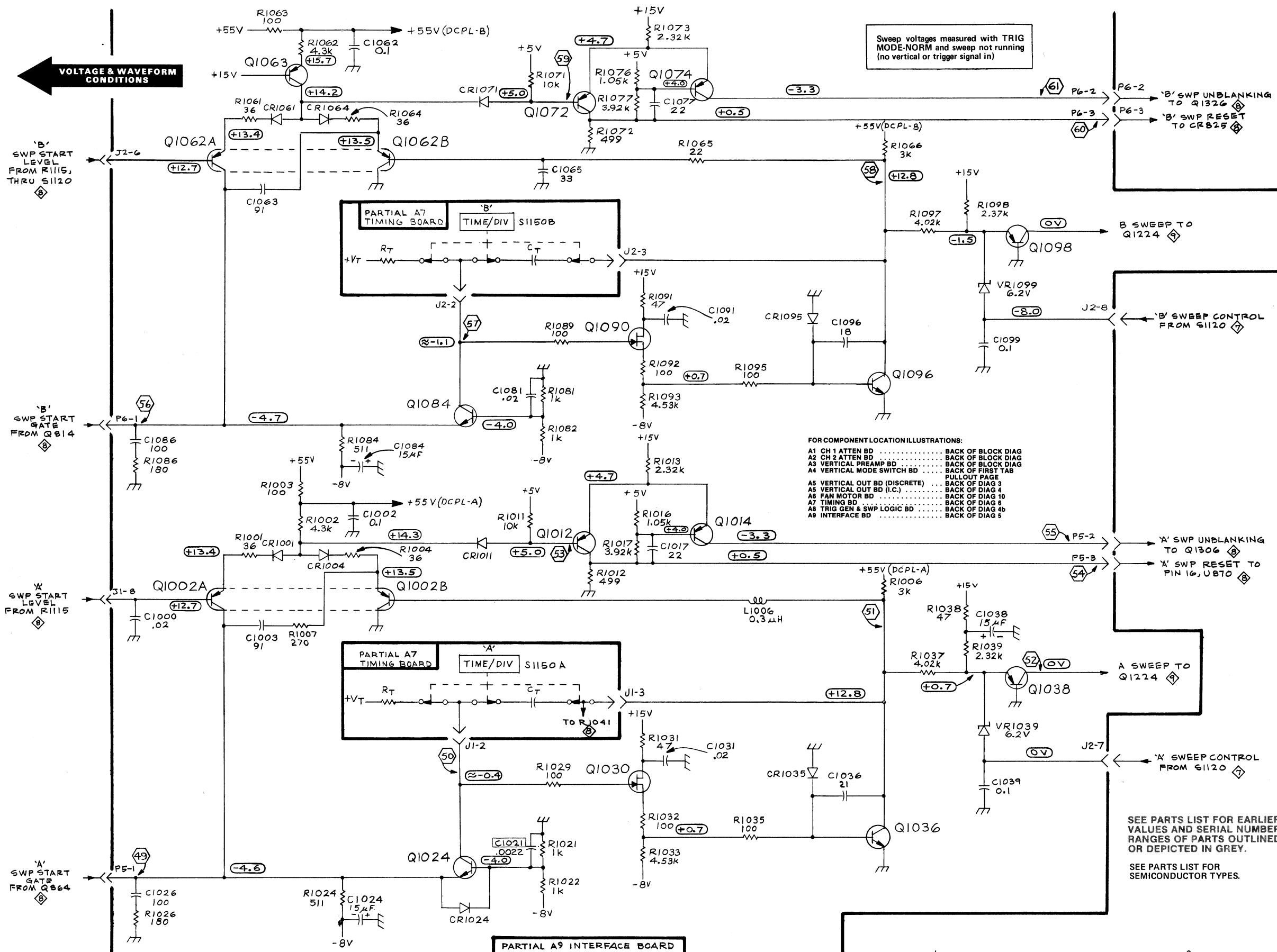

Sweep voltages measured with TRIG MODE-NORM and sweep not running (no vertical or trigger signal in)

- FOR COMPONENT LOCATION ILLUSTRATIONS:
- A1 CH 1 ATTEN BD BACK OF BLOCK DIAG
 - A2 CH 2 ATTEN BD BACK OF BLOCK DIAG
 - A3 VERTICAL PREAMP BD BACK OF BLOCK DIAG
 - A4 VERTICAL MODE SWITCH BD BACK OF FIRST TAB
 - A5 VERTICAL OUT BD (DISCRETE) PULLOUT PAGE
 - A5 VERTICAL OUT BD (I.C.) BACK OF DIAG 3
 - A6 FAN MOTOR BD BACK OF DIAG 4
 - A7 TIMING BD BACK OF DIAG 10
 - A8 TRIG GEN & SWP LOGIC BD BACK OF DIAG 8
 - A9 INTERFACE BD BACK OF DIAG 5

SEE PARTS LIST FOR EARLIER VALUES AND SERIAL NUMBER RANGES OF PARTS OUTLINED OR DEPICTED IN GREY.
SEE PARTS LIST FOR SEMICONDUCTOR TYPES.

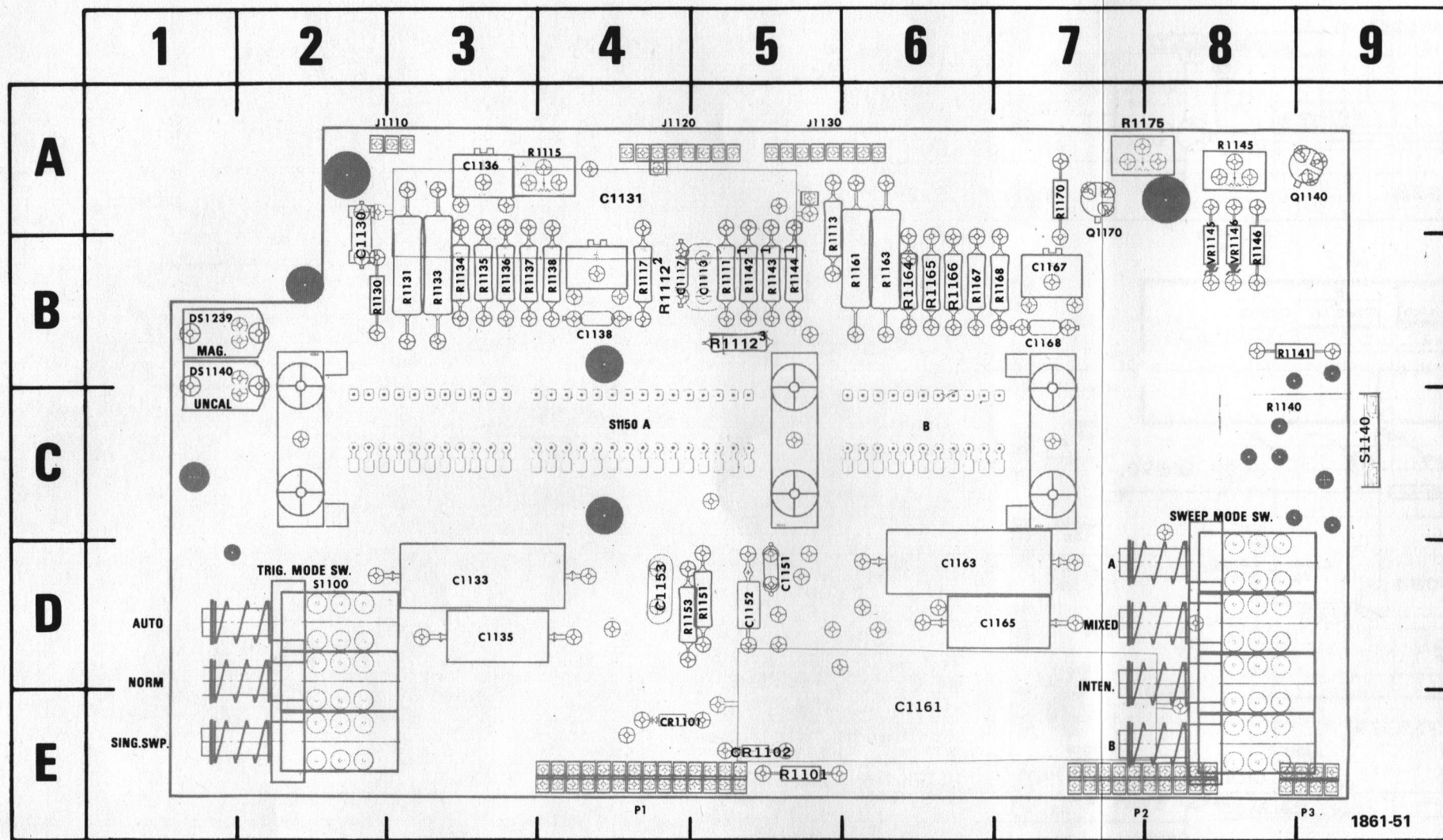

Fig. 8-8. A7—Timing circuit board.

*See parts list for serial number ranges.

† Located on back of board.

1 On instruments with DM only.

² Location for standard 465

³ Location for DM

CKT NO	GRID LOC	CKT NO	GRID LOC	CKT NO	GRID LOC	CKT NO	GRID LOC
C1113	5B	CR1153†*		R1112 ²	4B	R1153	4D
C1117	4B			R1113	5A	R1161	6B
C1130	2A	DS1140	1B	R1115	4A	R1163	6B
C1131	4A	DS1239	1B	R1117	4B	R1164	6B
C1133	3D			R1130	2B	R1165	6B
C1135	3D	J1110	2A	R1131	3B	R1166	6B
C1136	3A	J1120	4A	R1133	3B	R1167	6B
C1137†		J1130	5A	R1134	3B	R1168	7B
C1138	4B			R1135	3B	R1170	7A
C1151	5D	P1	4E	R1136	3B	R1175	7A
C1152	5D	P2	7E	R1137	3B		
C1153	4D	P3	9E	R1138	4B	S1100	2D
C1161	6E			R1140	8C	S1120 †	
C1163	6D	Q1140	9A	R1141	9B	S1140	9C
C1165	7D	Q1170	7A	R1142 ¹	5B	S1150A	4C
C1167	7B			R1143 ¹	5B		
C1168	7B	R1101	5E	R1144 ¹	5B	VR1145	8B
		R1111	5B	R1145	8A	VR1146	8B
CR1101	4E	R1112	5B	R1146	8B		
CR1102	5E	R1112 ³	5B	R1151	5D		

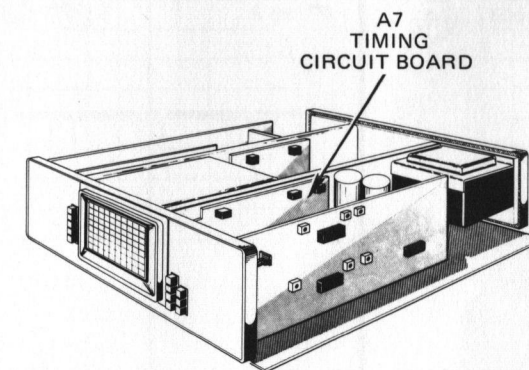

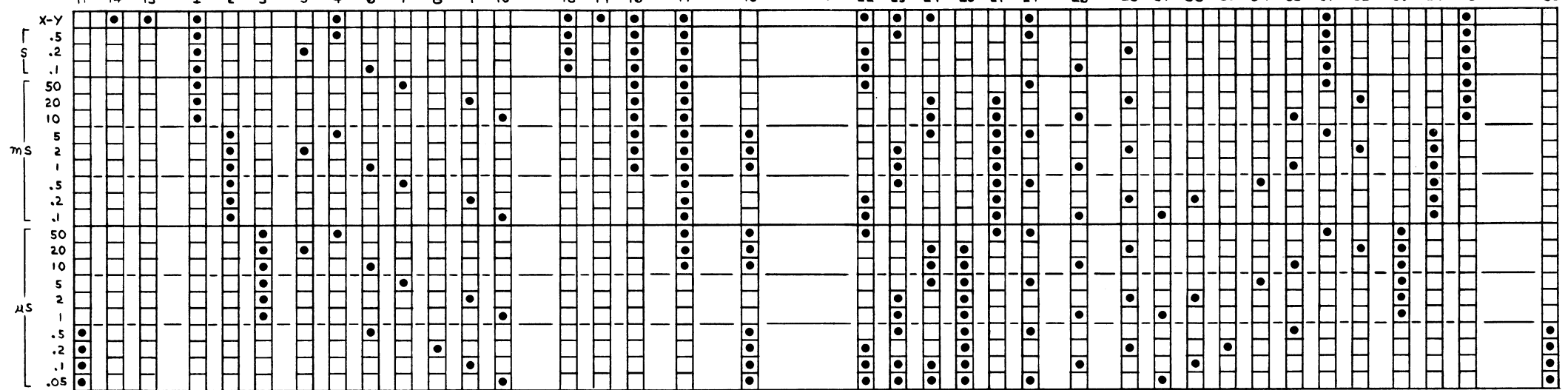
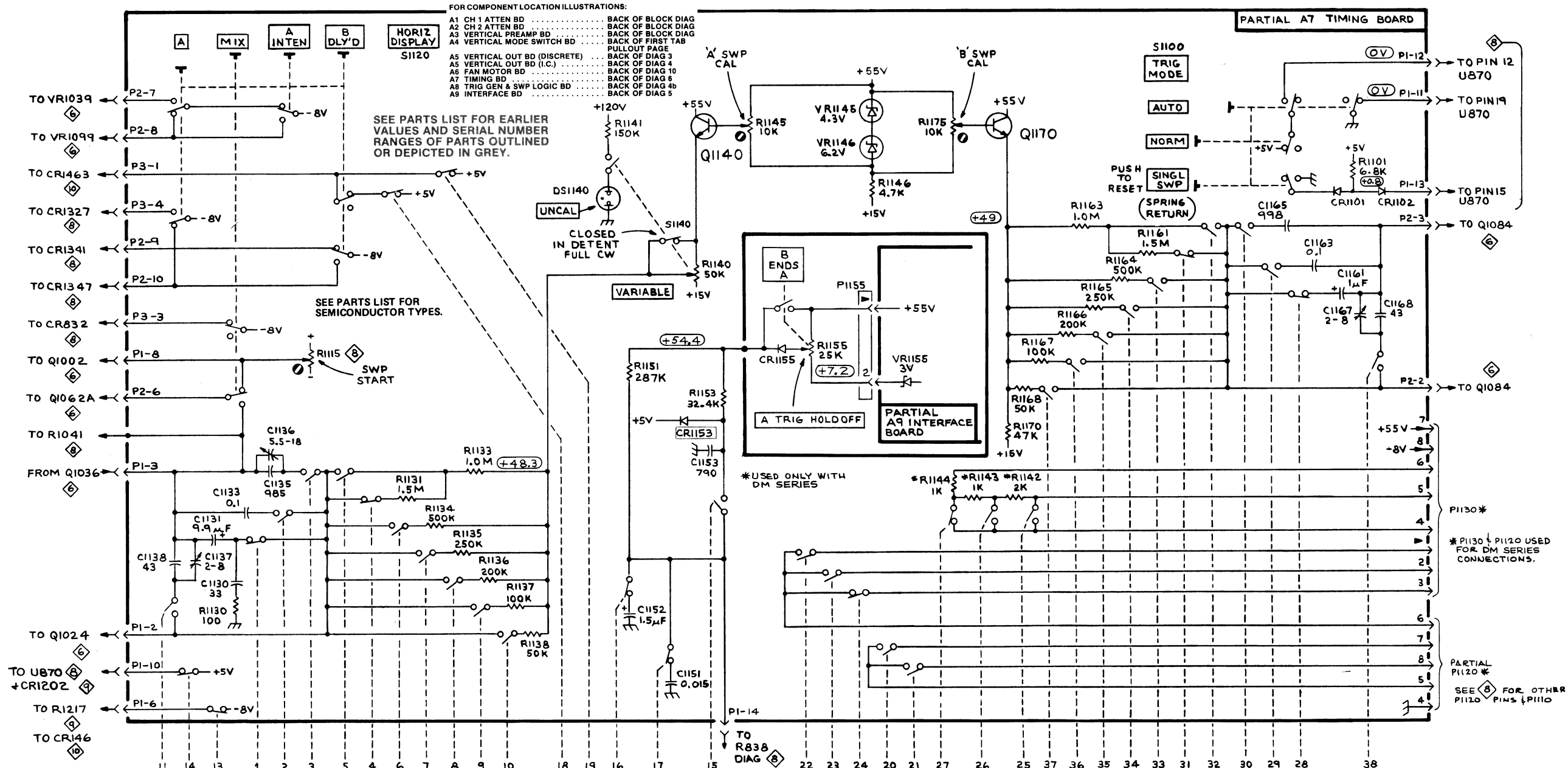

A & B TIMING SWITCH

7

*PI130 & PI120 USED FOR DM SERIES CONNECTIONS.

PARTIAL PI120 *
SEE FOR OTHER PI120 PINS & PI110

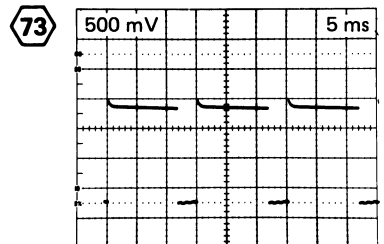
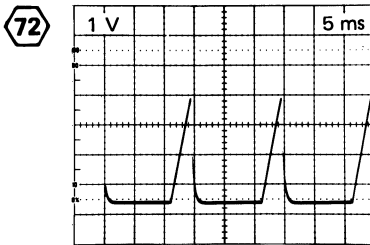
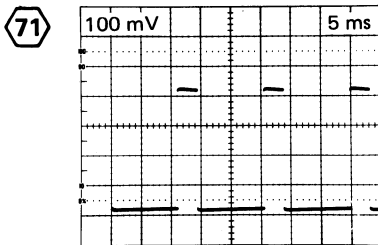
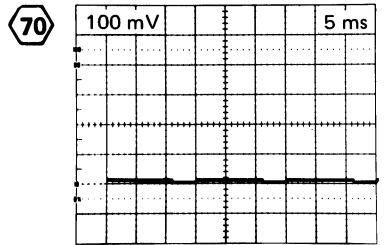
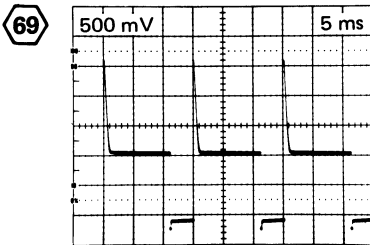
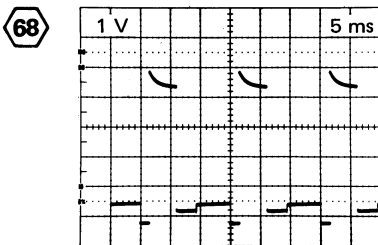
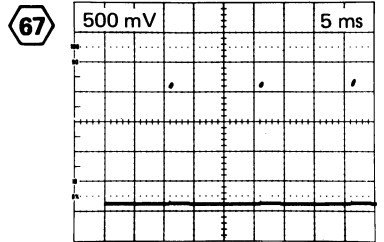
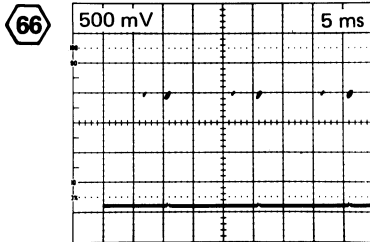
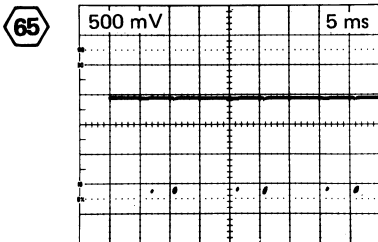
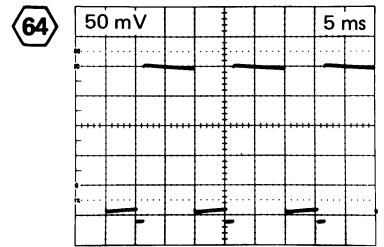
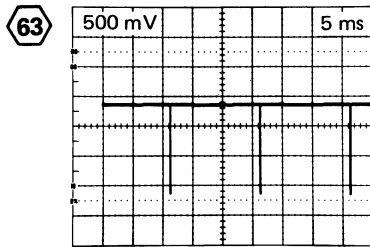
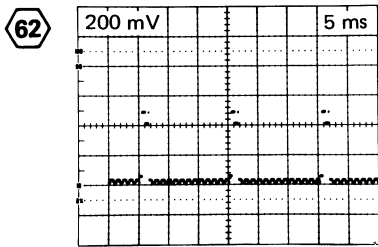

465 display untriggered (free running).

The slope and time duration of this waveform is dependent on the setting of the A Trigger Holdoff control.

465 display triggered (stable).

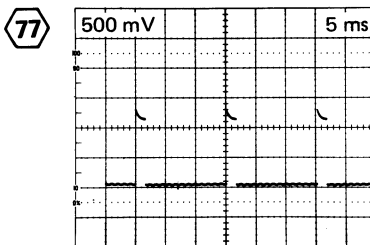
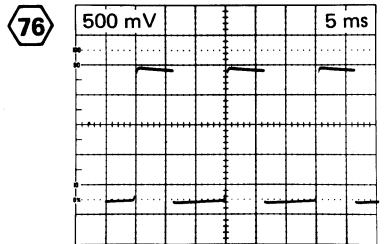
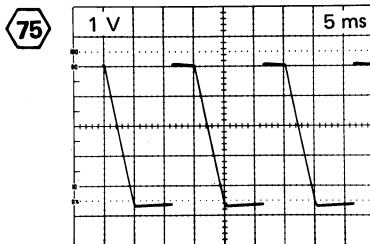
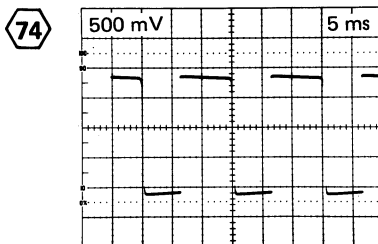

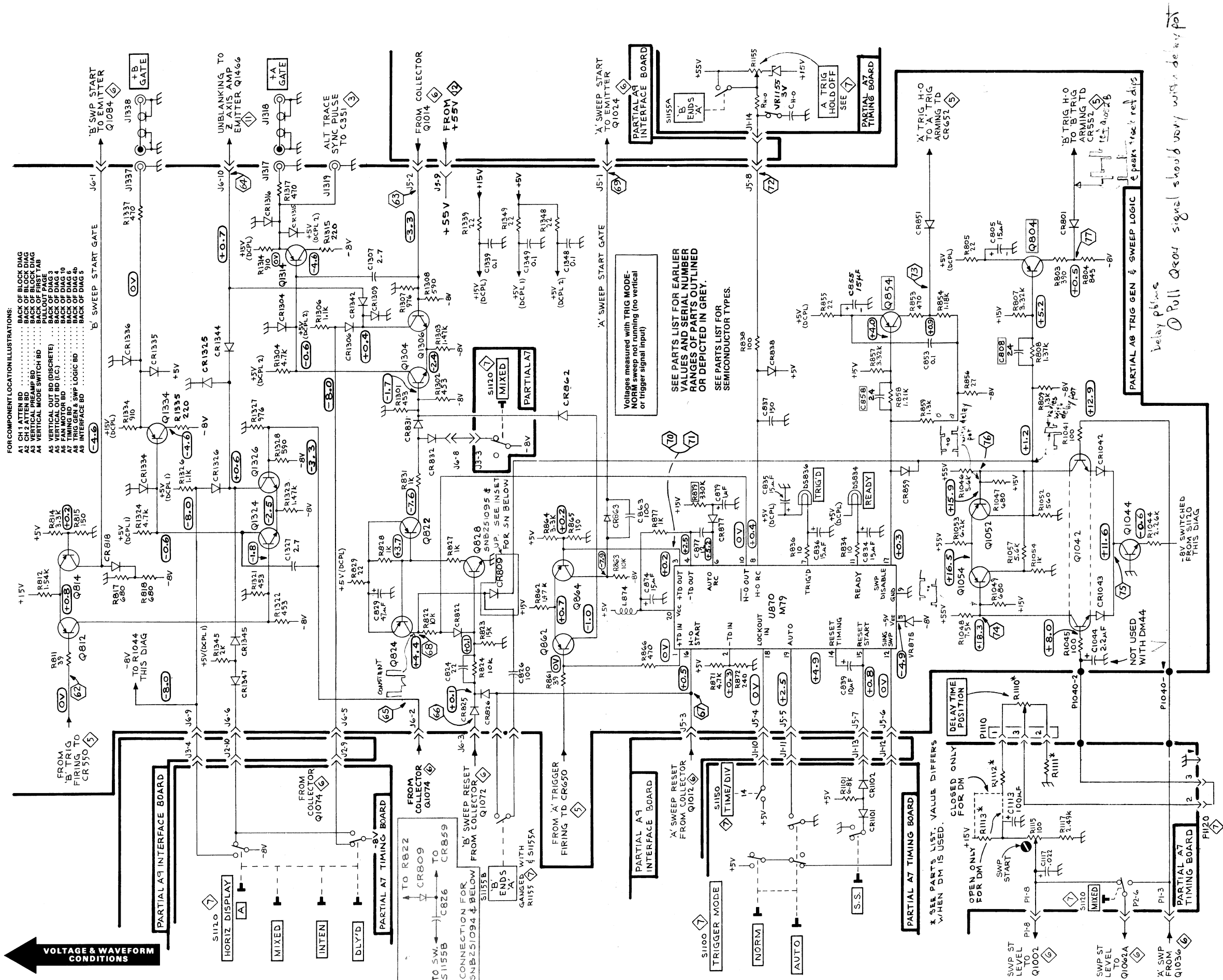

FOR COMPONENT LOCATION ILLUSTRATIONS:
 A1 CH 1 ATTEN BD BACK OF BLOCK DIAG
 A2 CH 2 ATTEN BD BACK OF BLOCK DIAG
 A3 VERTICAL PREAMP BD BACK OF BLOCK DIAG
 A4 VERTICAL MODE SWITCH BD PART 1 TAB
 A5 VERTICAL OUT BD (DISCRETE) PULL OUT PAGE
 A6 VERTICAL OUT BD (I.C.) BACK OF DIAG 4
 A7 TRIG GEN & SWP LOGIC BD BACK OF DIAG 5
 A8 TRIG GEN & SWP LOGIC BD BACK OF DIAG 5
 A9 INTERFACE BD BACK OF DIAG 5

VOLTAGE & WAVEFORM CONDITIONS

SEE PARTS LIST FOR EARLIER VALUES AND SERIAL NUMBER RANGES OF PARTS OUTLINED OR DEPICTED IN GREY.
 SEE PARTS LIST FOR SEMICONDUCTOR TYPES.

Voltages measured with TRIG MODE-NORM sweep not running (no vertical or trigger signal input)

* SEE PARTS LIST, VALUE DIFFERS WHEN DM IS USED.

PARTIAL AB TRIG GEN & SWEEP LOGIC
 Delay pt's
 Pull Q1004 signal should vary with delay pt

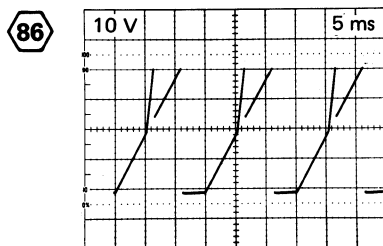
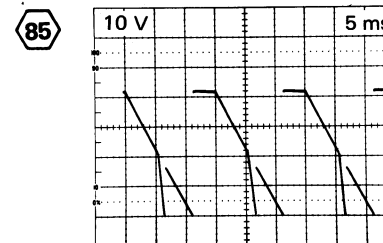
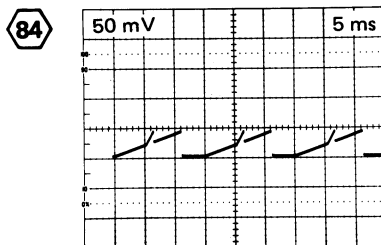
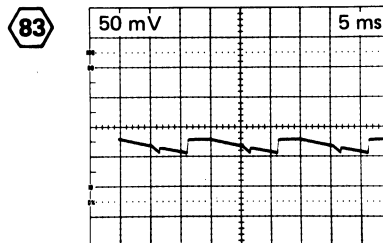
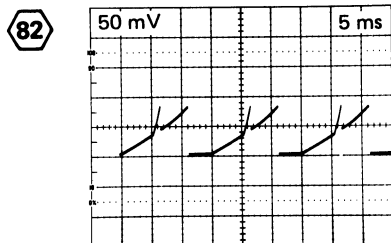
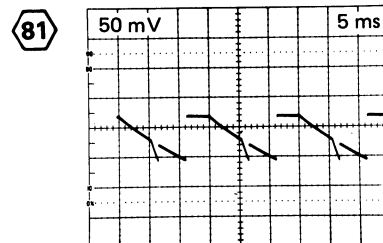
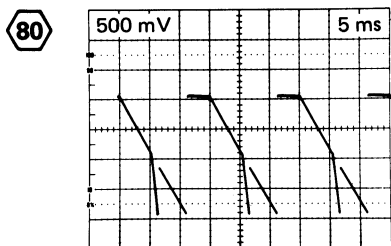
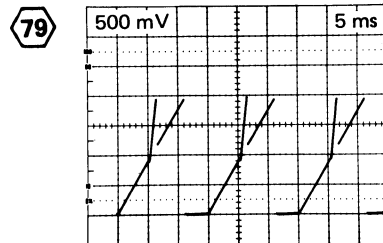
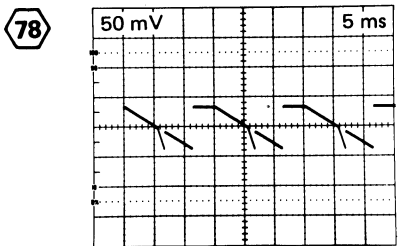

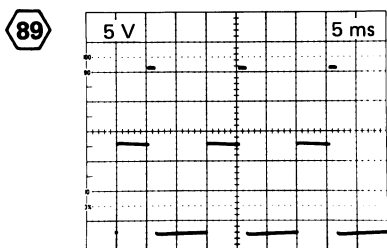
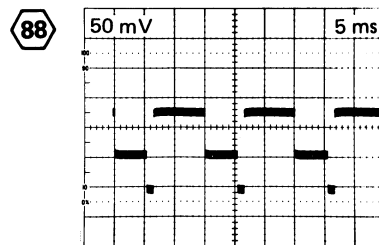
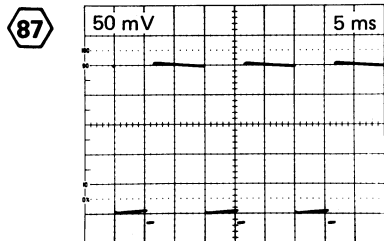

The amplitude of this waveform varies from 0 volts to 75 volts peak-to-peak depending on the setting of the Intensity control.

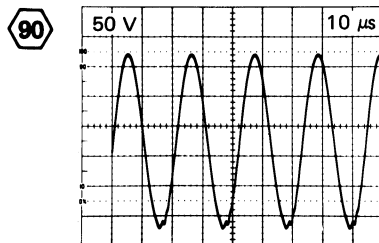

Set the test scope Trigger Source switch to Normal.

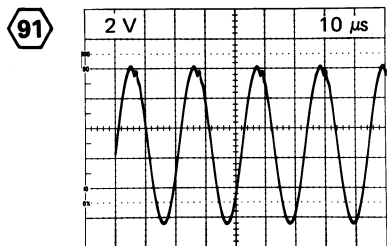

Set the test scope Trigger Source switch to Normal.

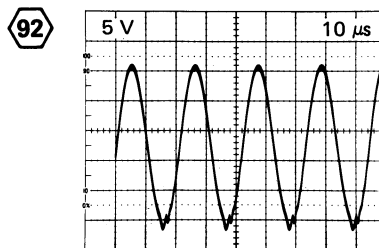

Set the test scope Trigger Source switch to Normal.

VOLTAGE & WAVEFORM CONDITIONS

HORIZ DISPLAY S1120

+5V +5V TIME/DIV S1150

SEE PARTS LIST FOR SEMICONDUCTOR TYPES.

Z axis voltages taken with intensity set midrange (normal)

SEE PARTS LIST FOR EARLIER VALUES AND SERIAL NUMBER RANGES OF PARTS OUTLINED OR DEPICTED IN GREY.

FOR COMPONENT LOCATION ILLUSTRATIONS:

A1 CH 1 ATTN BD	BACK OF BLOCK DIAG
A2 CH 2 ATTN BD	BACK OF BLOCK DIAG
A3 VERTICAL PREAMP BD	BACK OF BLOCK DIAG
A4 VERTICAL MODE SWITCH BD	BACK OF FIRST TAB PULLOUT PAGE
A5 VERTICAL OUT BD (DISCRETE)	BACK OF DIAG 3
A5 VERTICAL OUT BD (I.C.)	BACK OF DIAG 4
A6 FAN MOTOR BD	BACK OF DIAG 10
A7 TIMING BD	BACK OF DIAG 6
A8 TRIG GEN & SWP LOGIC BD	BACK OF DIAG 4b
A9 INTERFACE BD	BACK OF DIAG 5

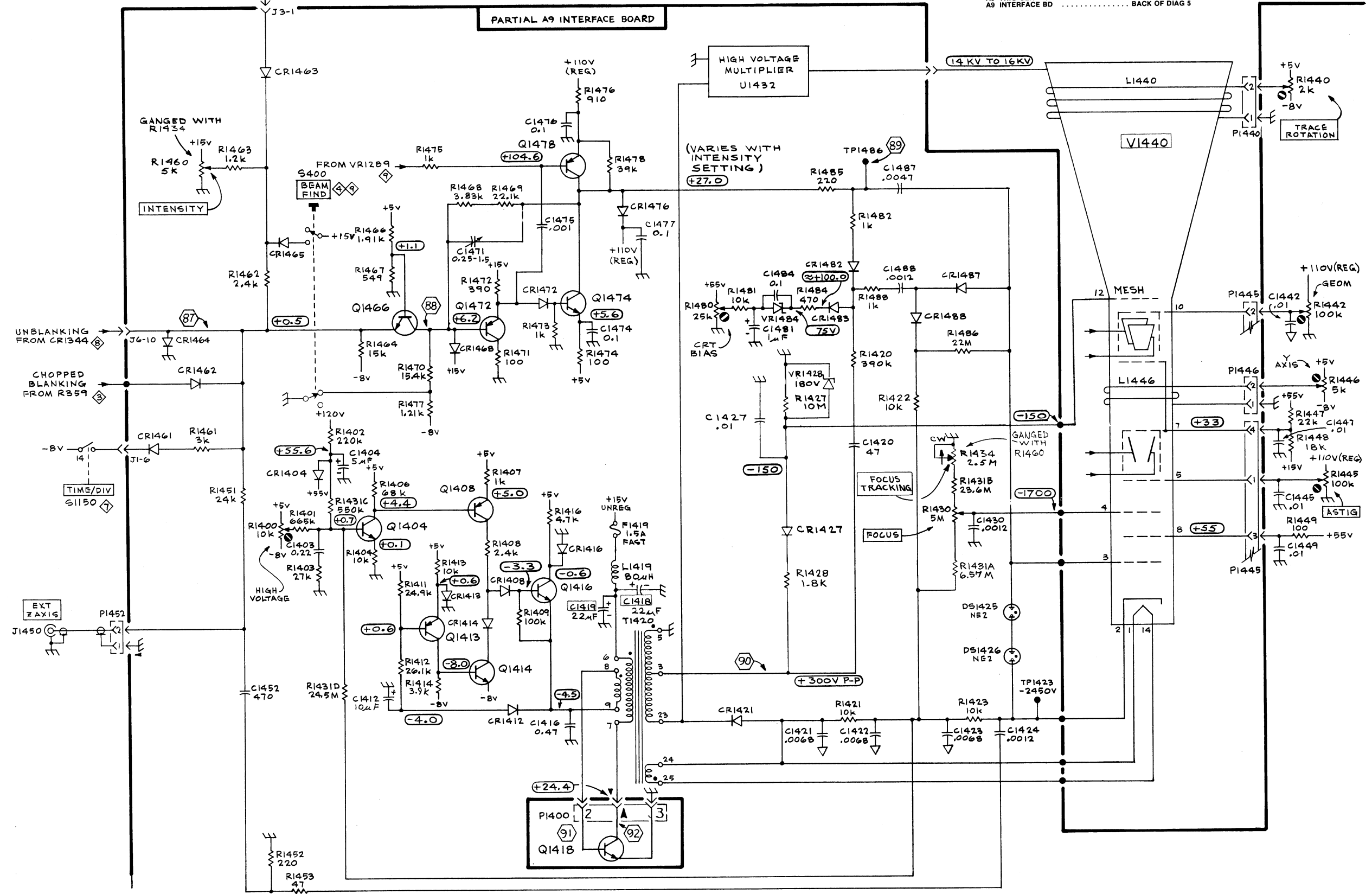

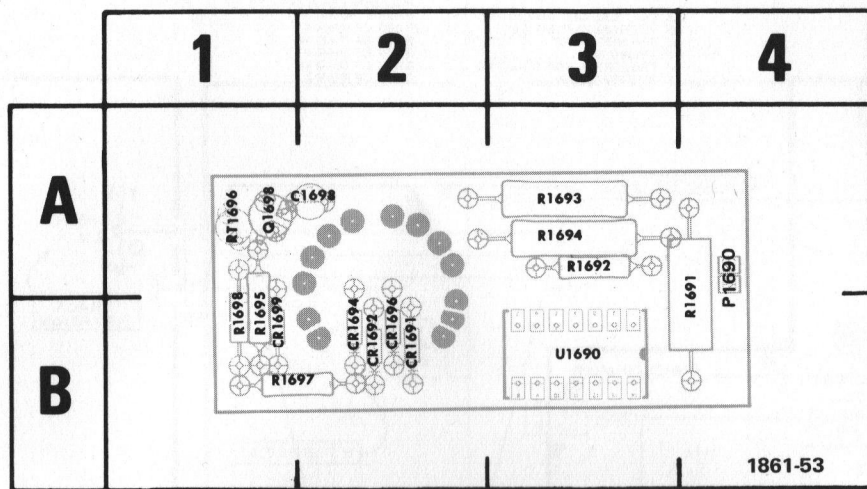
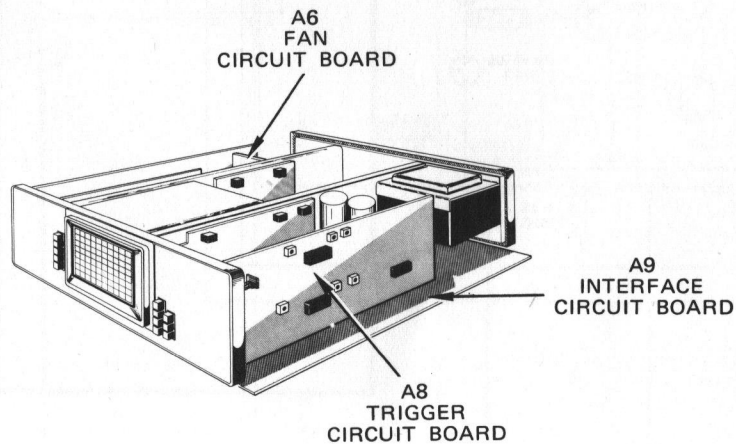

Fig. 8-9. A6—Fan circuit board.

CKT NO	GRID LOC	CKT NO	GRID LOC
C1698	2A	R1692	3A
		R1693	3A
CR1691	2B	R1694	3A
CR1692	2B	R1697	1B
CR1694	2B	R1698	1B
CR1696	2B	R1695	1B
CR1699	1B	RT1696	1A
P1690	4A		
Q1698	1A	U1690	3B
R1691	4A		



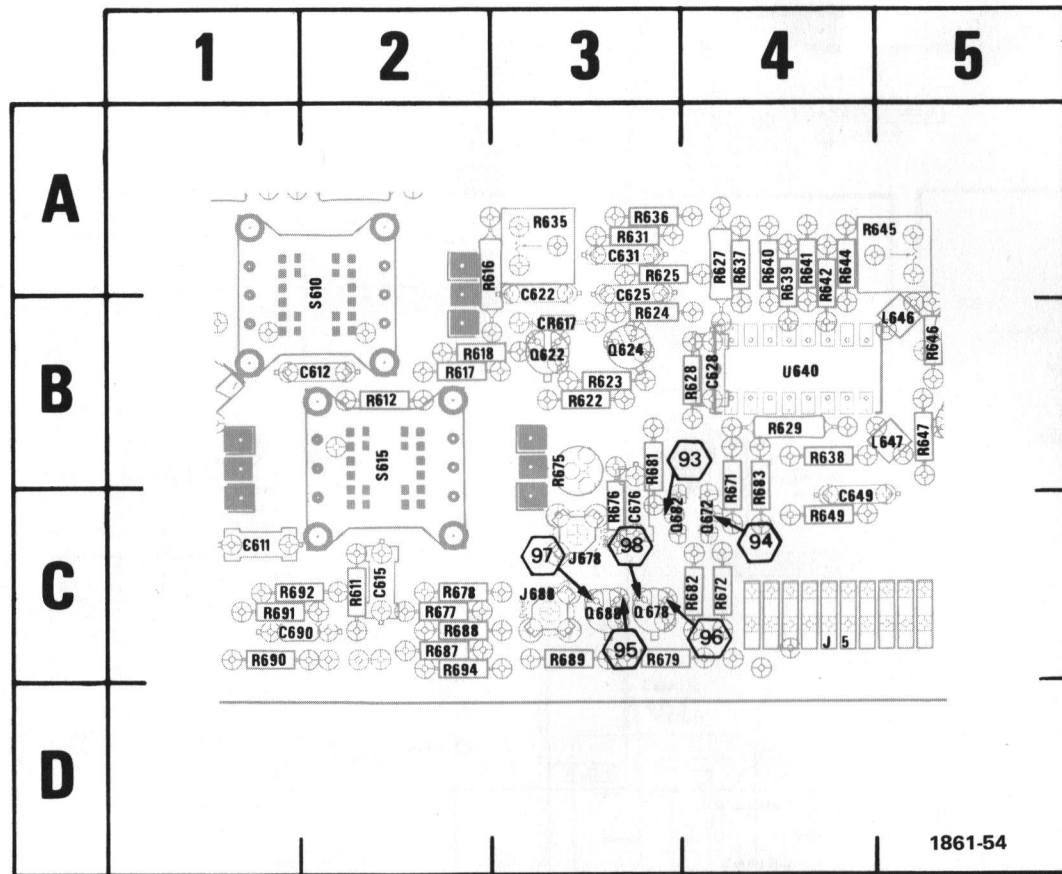

Fig. 8-10. Partial A8—Trigger Generator and Sweep Logic circuit board.

CKT NO	GRID LOC	CKT NO	GRID LOC	CKT NO	GRID LOC	CKT NO	GRID LOC
C611	1C	Q622	3B	R631	3A	R678	2C
C612	2B	Q624	3B	R635	3A	R679	3C
C615	2C	Q672	4C	R636	3A	R681	3B
C622	3A	Q678	3C	R637	4A	R682	4C
C625	3A	Q682	3C	R638	4B	R683	4C
C628	4B	Q688	3C	R639	4A	R687	2C
C631	3A			R640	4A	R688	2C
C649	4C	R611	2C	R641	4A	R689	3C
C676	3C	R612	2B	R642	4A	R690	1C
C690	1C	R616	2A	R644	4A	R691	1C
		R617	2B	R645	5A	R692	1C
CR617	3B	R618	2B	R646	5B	R694	2C
		R622	3B	R647	5B		
J5	4C	R623	3B	R649	4C	S610	2A
J678	3C	R624	3B	R671	4C	S615	2B
J688	3C	R625	3A	R672	4C		
		R627	4A	R675	3B	U640	4B
L646	5B	R628	4B	R676	3C		
L647	5B	R629	4B	R677	2C		

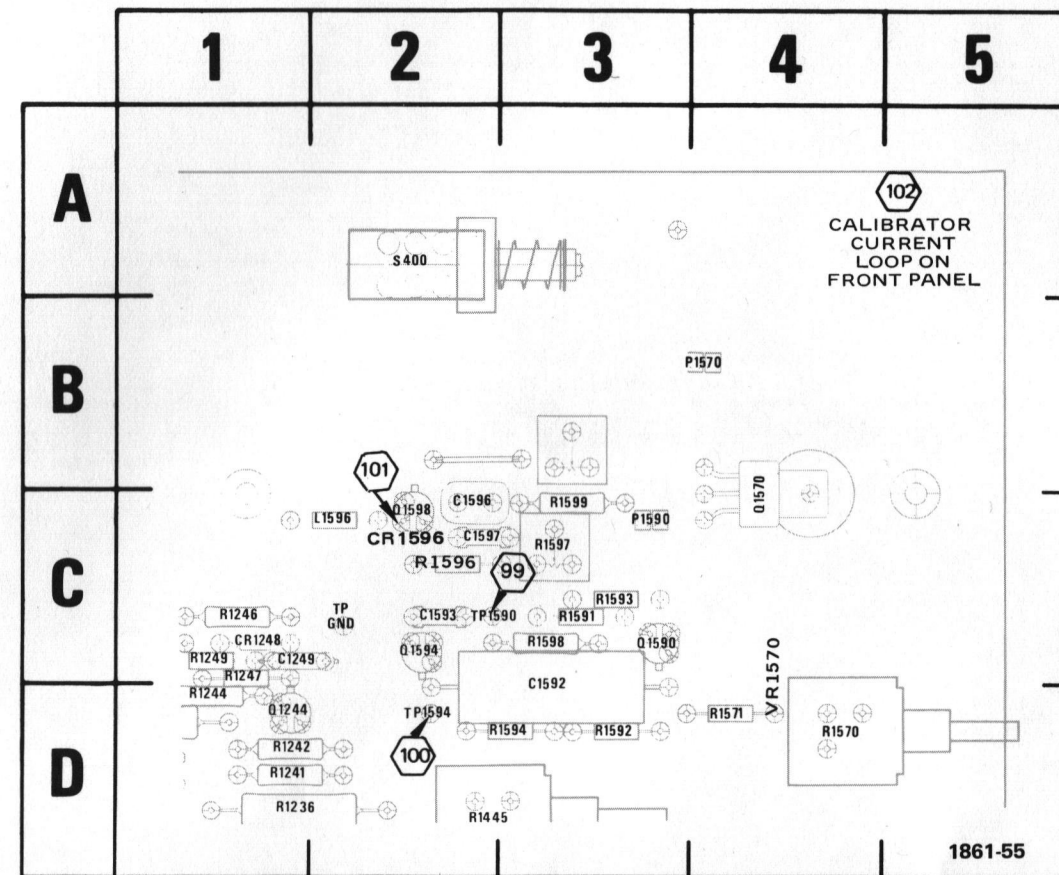
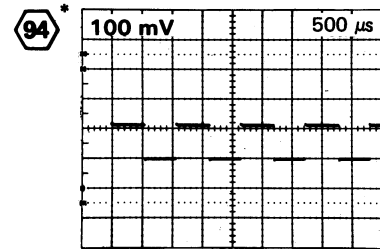
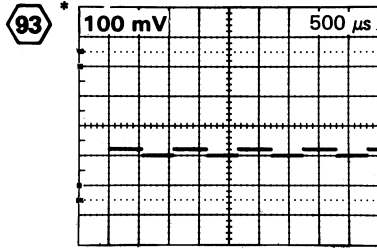

Fig. 8-11. Partial A9—Interface circuit board. (Calibrator Components)

CKT NO	GRID LOC	CKT NO	GRID LOC	CKT NO	GRID LOC
C1249	1C	Q1570	4C	R1571	4D
C1592	3C	Q1590	3C	R1591	3C
C1593	2C	Q1594	2C	R1592	3D
C1596	2C	Q1598	2C	R1593	3C
C1597	2C			R1594	3D
		R1236	1D	R1596	2C
CR1248	1C	R1241	1D	R1597	3C
CR1596	2C	R1242	1D	R1598	3C
L1596	2C	R1244	1D	R1599	3C
		R1246	1C		
P1570	4B	R1247	1C	S400	2A
P1590	3C	R1249	1C	TP1590	2C
		R1445	2D	TP1594	2D
Q1244	1D	R1570	4D	TP GND	2C
				VR1570	4C

For Waveforms 93 through 98: 465 trigger-view button pushed in and held.



*Waveform amplitudes are approximate and may vary from instrument to instrument.

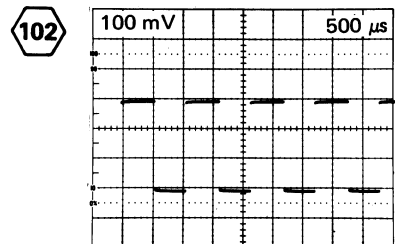
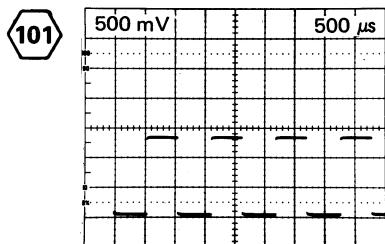
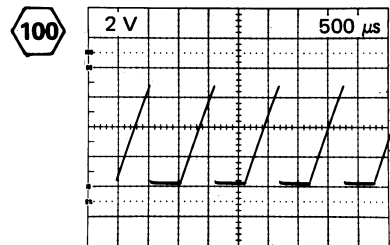
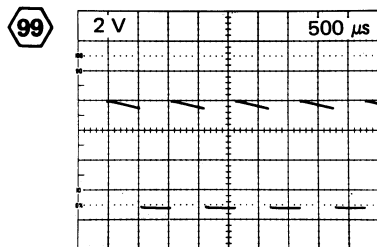
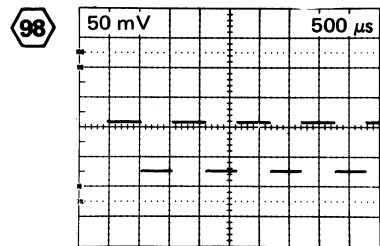
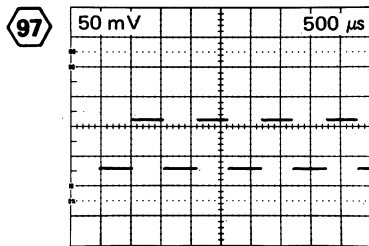
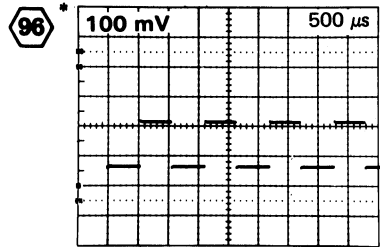
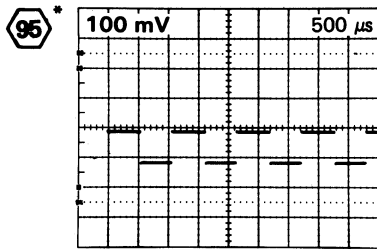

VOLTAGE & WAVEFORM CONDITIONS

PARTIAL A9 INTERFACE BOARD

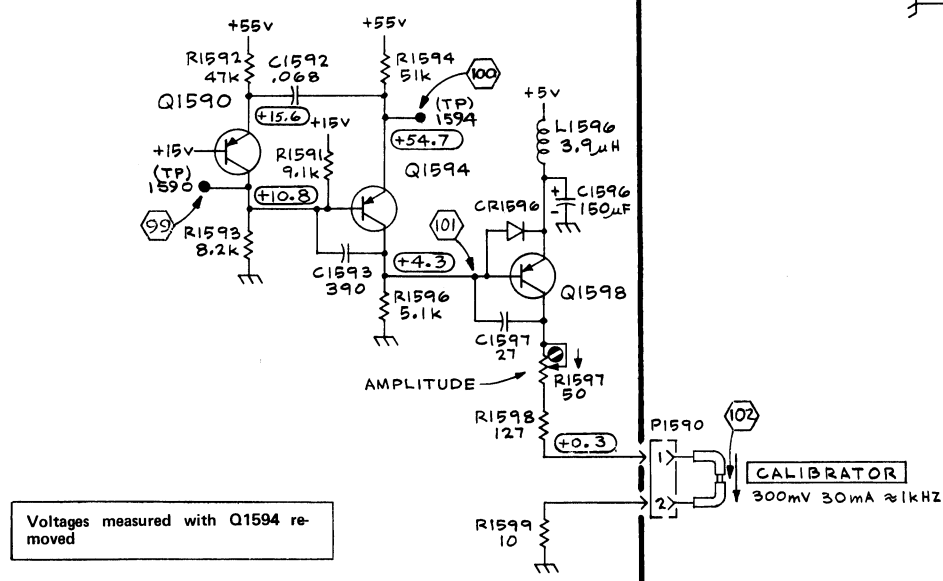

A6 FAN MOTOR BOARD

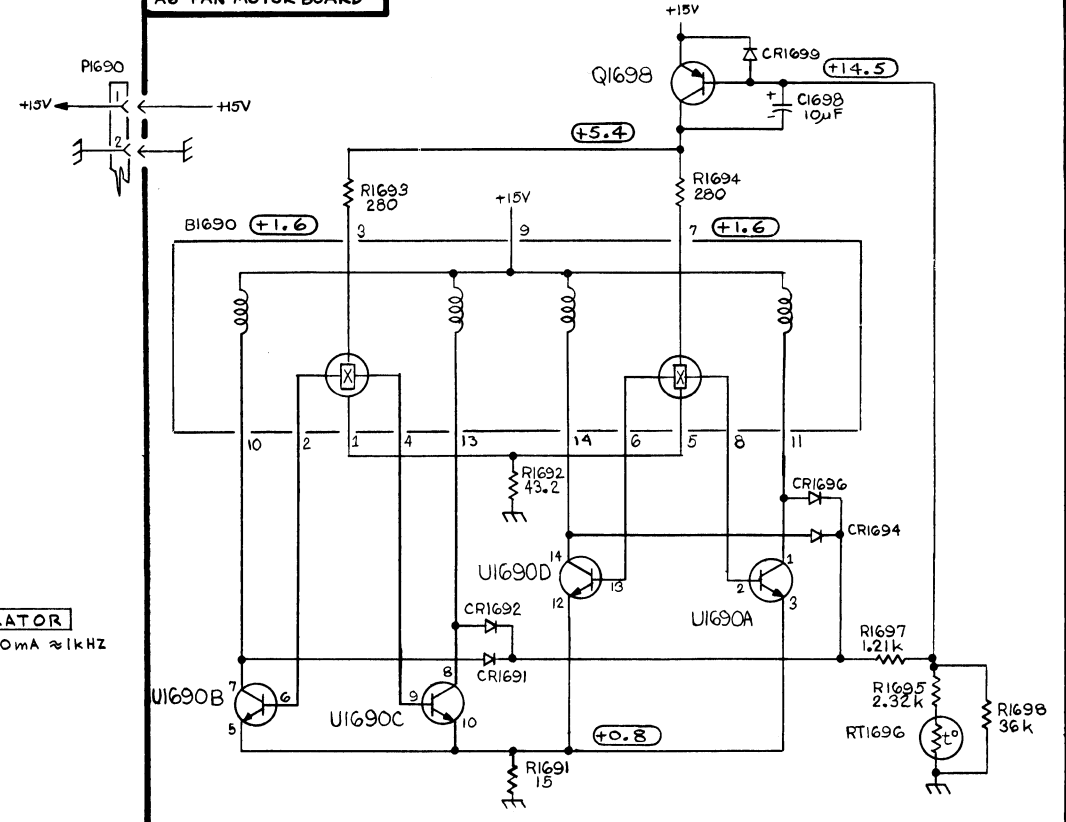

PARTIAL A3 PREAMP BRD

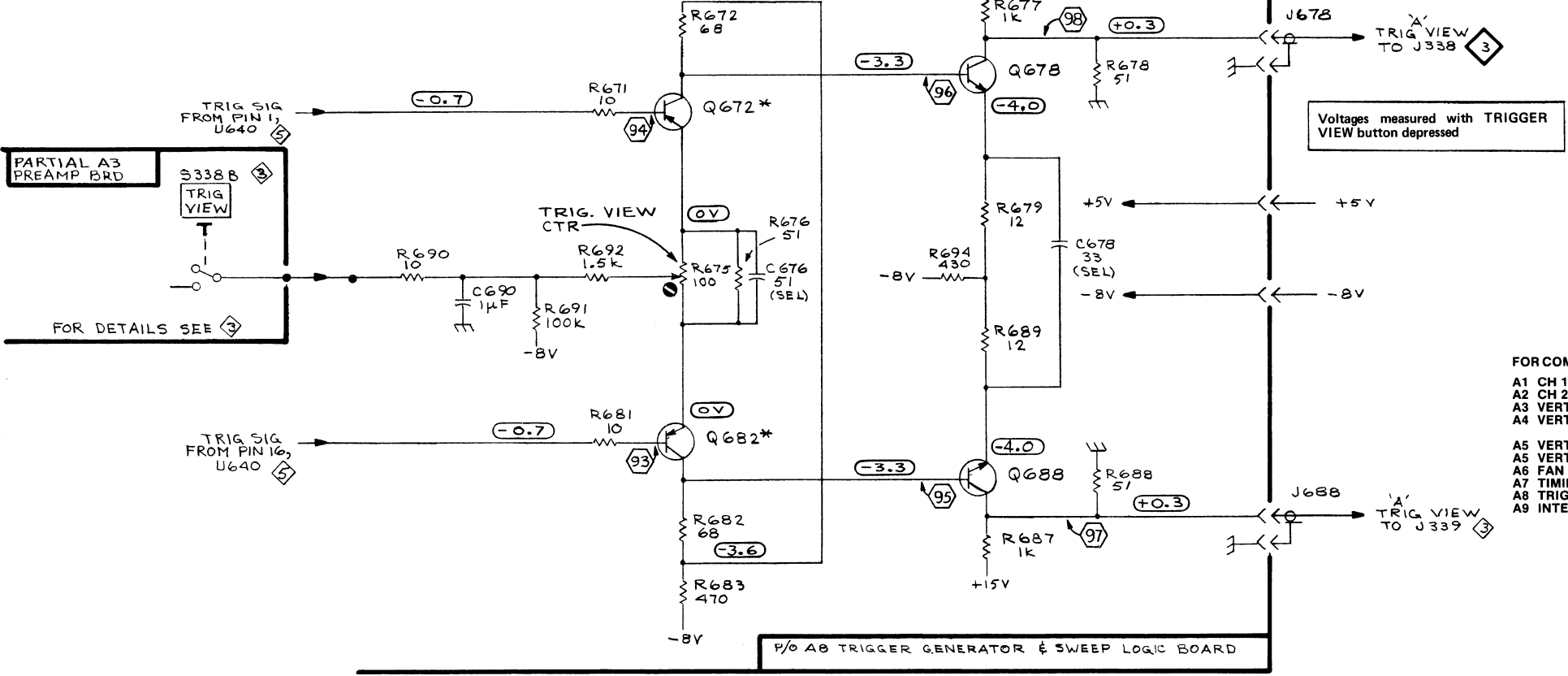

- SEE PARTS LIST FOR SEMICONDUCTOR TYPES.
- FOR COMPONENT LOCATION ILLUSTRATIONS:
- A1 CH 1 ATTEN BD BACK OF BLOCK DIAG
 - A2 CH 2 ATTEN BD BACK OF BLOCK DIAG
 - A3 VERTICAL PREAMP BD BACK OF BLOCK DIAG
 - A4 VERTICAL MODE SWITCH BD BACK OF FIRST TAB
 - A5 VERTICAL OUT BD (DISCRETE) PULLOUT PAGE
 - A5 VERTICAL OUT BD (I.C.) BACK OF DIAG 4
 - A6 FAN MOTOR BD BACK OF DIAG 10
 - A7 TIMING BD BACK OF DIAG 6
 - A8 TRIG GEN & SWP LOGIC BD BACK OF DIAG 4b
 - A9 INTERFACE BD BACK OF DIAG 5

* THERMAL COUPLED

'A' TRIGGER VIEW, CALIBRATOR AND FAN

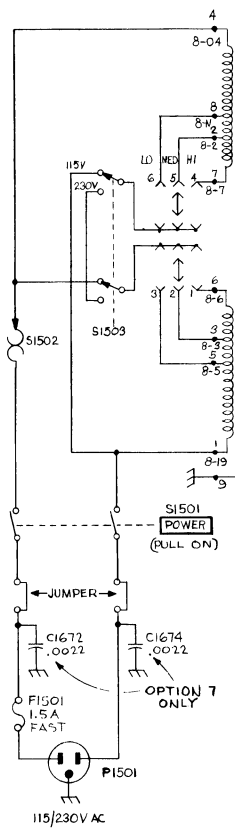
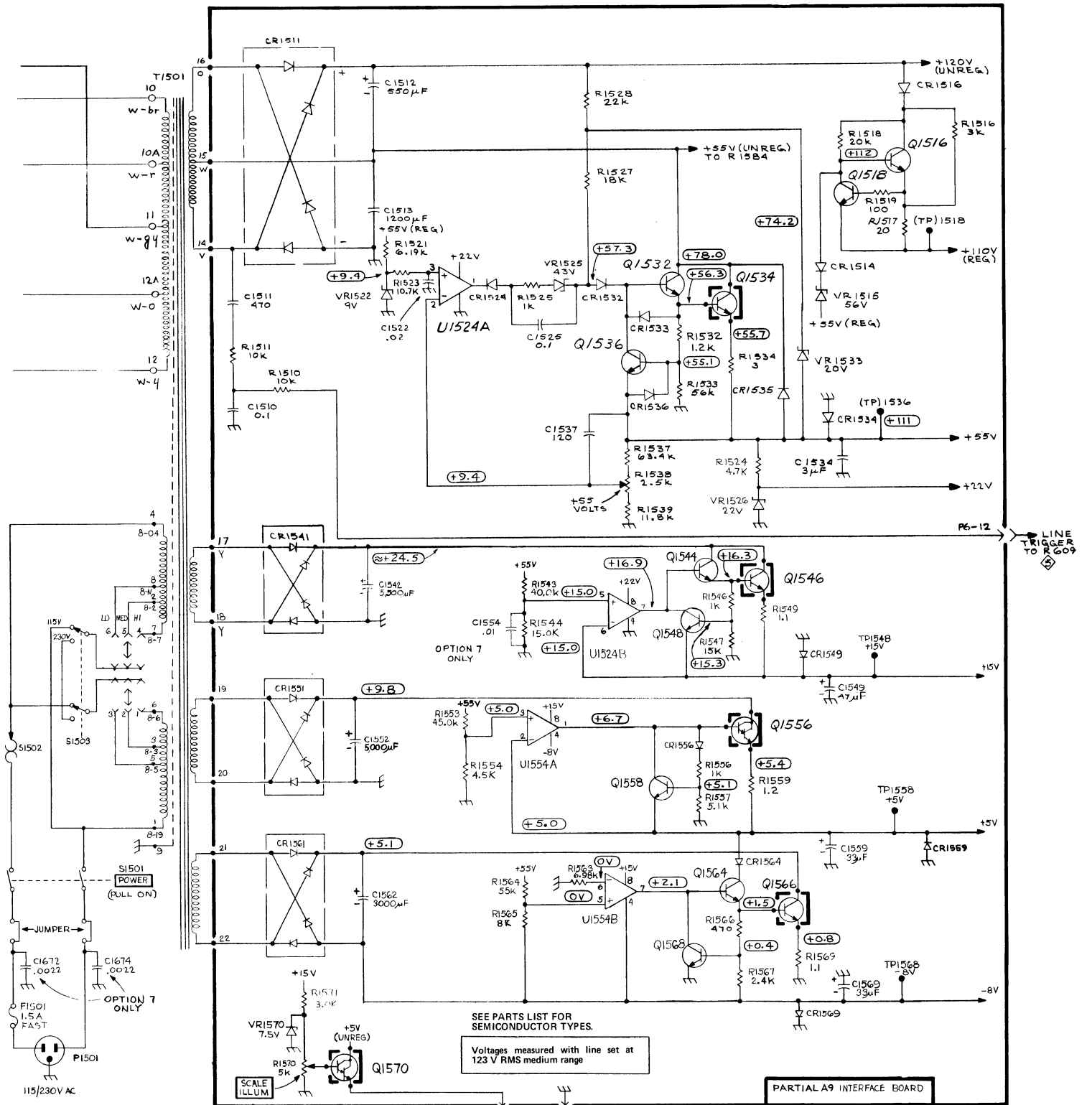

- FOR COMPONENT LOCATION ILLUSTRATIONS:
- A1 CH 1 ATTEN BD BACK OF BLOCK DIAG
 - A2 CH 2 ATTEN BD BACK OF BLOCK DIAG
 - A3 VERTICAL PREAMP BD BACK OF BLOCK DIAG
 - A4 VERTICAL MODE SWITCH BD BACK OF FIRST TAB
 - A5 VERTICAL OUT BD (DISCRETE) BACK OF DIAG 3
 - A5 VERTICAL OUT BD (I.C.) BACK OF DIAG 4
 - A6 FAN MOTOR BD BACK OF DIAG 10
 - A7 TIMING BD BACK OF DIAG 6
 - A8 TRIG GEN & SWP LOGIC BD BACK OF DIAG 4b
 - A9 INTERFACE BD BACK OF DIAG 5

SEE PARTS LIST FOR SEMICONDUCTOR TYPES.
 Voltages measured with line set at 123 V RMS medium range

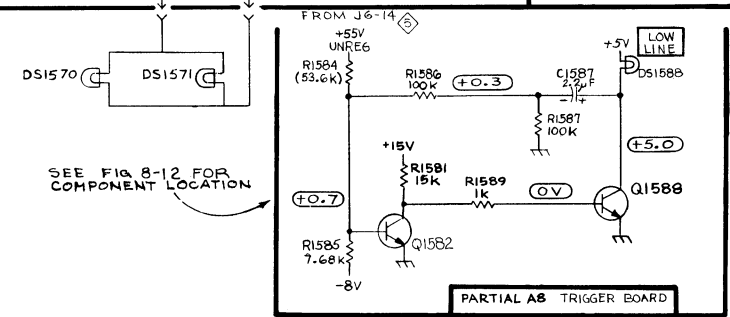

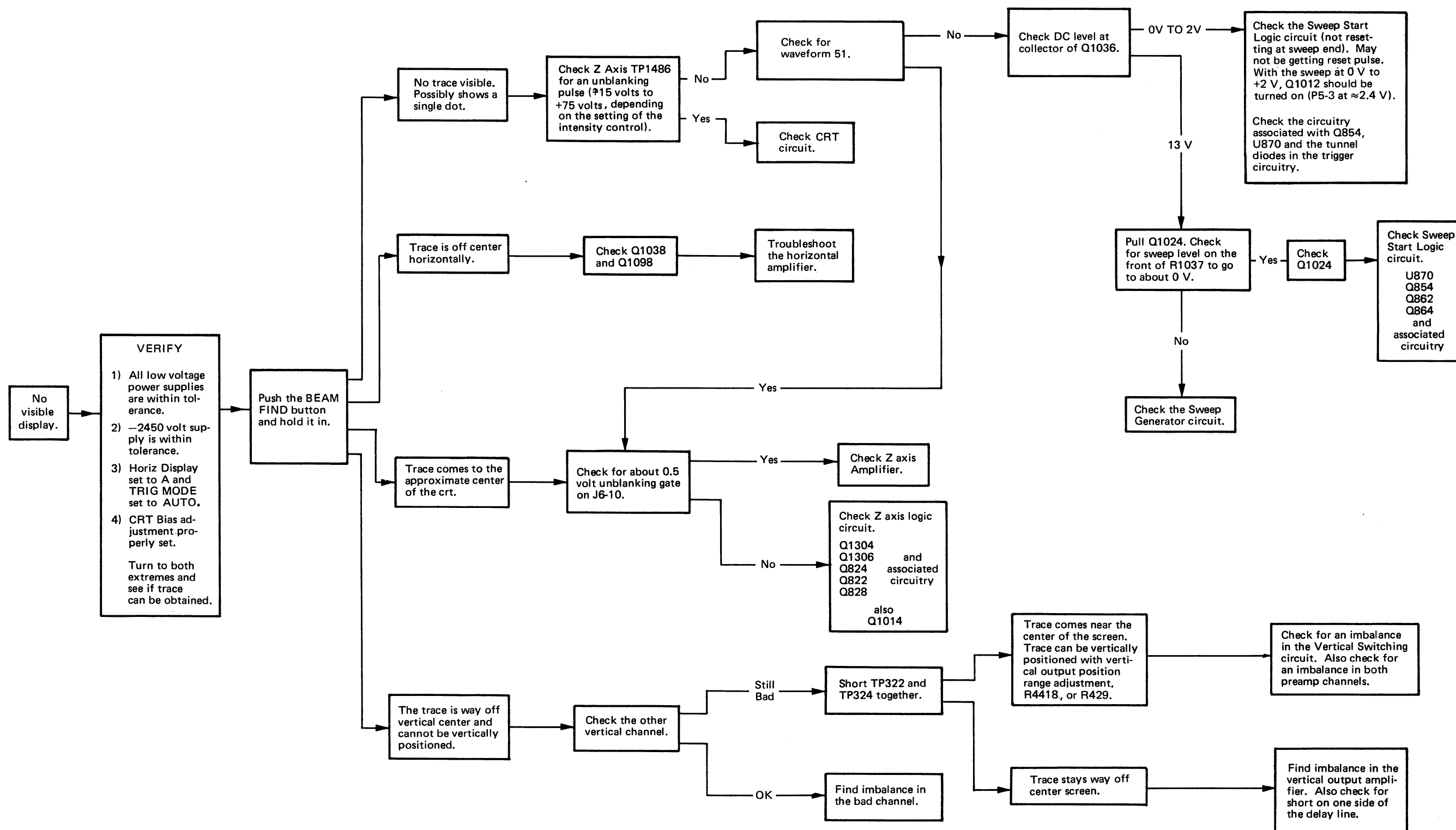

POWER SUPPLY ISOLATION PROCEDURE

The following procedure is used as an aid in localizing the area in which loading of a power supply occurs. If the power supply comes up after isolating a circuit, it is very probable the problem is in that circuit. This can sometimes, however, lead to erroneous conclusions as a supply may pass through one circuit to another circuit. For instance, the +5 volt supply enters the timing board through P2-4. It then passes through the timing switch (in the X-Y position only) and P1-10 to CR1202 in the horizontal amplifier circuit. From P1-10 it also passes through P5-4 to the sweep control IC on the trigger board. Watch for these types of conditions when trying to localize a loading problem.

+55 Volt Supply

1. Pull P300 from the Interface board. This isolates the Vertical Preamp board.
2. Unsolder the dummy resistor near J-1. See adjustment locations 1 . This isolates the Timing board.
3. Pull P1155 from the front of the Interface board. This isolates the holdoff circuit.
4. To isolate the Trigger board from the +55 volt supply, it is necessary to remove the Trigger board from the instrument. The +55 volt supply connects to the Trigger board through P5-9. The +55 volt unregulated supply connects to the Trigger board through P6-14.



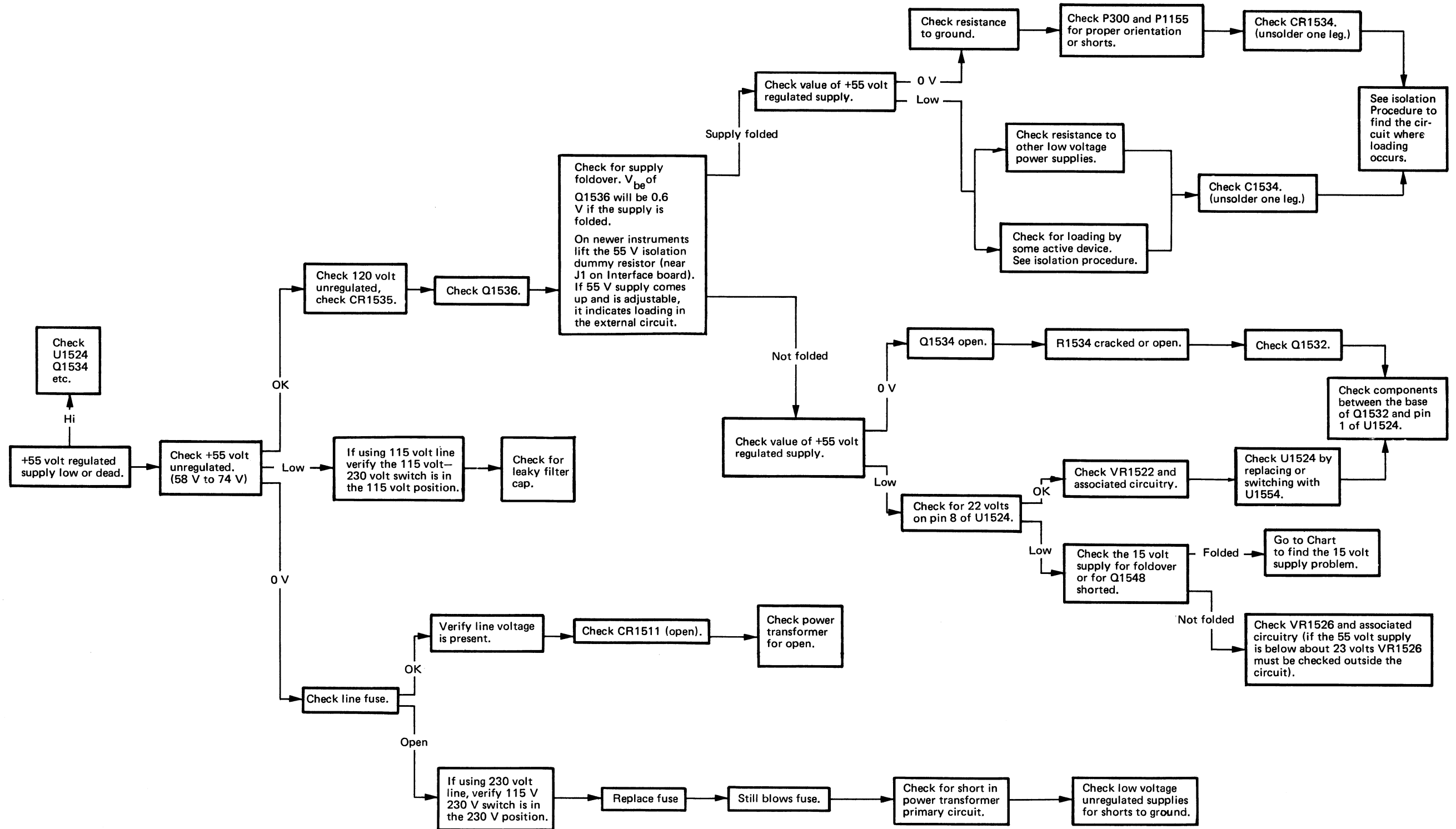

POWER SUPPLY ISOLATION PROCEDURE

The following procedure is used as an aid in localizing the area in which loading of a power supply occurs. If the power supply comes up after isolating a circuit, it is very probable the problem is in that circuit. This can sometimes, however, lead to erroneous conclusions as a supply may pass through one circuit to another circuit. For instance, the +5 volt supply enters the timing board through P2-4. It then passes through the timing switch (in the X-Y position only) and P1-10 to CR1202 in the horizontal amplifier circuit. From P1-10 it also passes through P5-4 to the sweep control IC on the trigger board. Watch for these types of conditions when trying to localize a loading problem.

+15 Volt Supply

1. Pull P300 from the Interface board. This isolates the Vertical Preamp board.
2. Unsolder the dummy resistor near J2. See adjustment locations 1. This isolates the Timing board.
3. Unsolder L891 on the Trigger board (see Fig. 8-6). This isolates most of the Trigger board. Also unsolder VR896 from the rear of the Trigger board (see Fig. 8-6). This isolates the +8 volt supply.
4. Pull P1690 from the Fan Motor board. This isolates the fan motor circuit.
5. Pull P4400 (P400 on IC version) from the Vertical Output Amplifier board. This isolates the Vertical Output Amplifier board.
6. Pull P1200 from the Interface board (see Fig. 8-7). This isolates the Horizontal Position and Fine controls.

+5 Volt Supply

1. Pull P300 from the Interface board. This isolates the Vertical Preamp board.
2. Unsolder the dummy resistor near J-2. See adjustment locations 1. This isolates the Timing board.
3. Unsolder L893 from the rear of the Trigger board (see Fig. 8-6). This isolates the Trigger board.
4. Pull P1155 from the Interface board (see Fig. 8-7). This isolates the holdoff circuitry.
5. Unsolder L1596 from the Interface board (see Fig. 8-11). This isolates the calibrator circuitry.

-8 Volt Supply

1. Pull P300 from the Interface board. This isolates the Vertical Preamp board.
2. Unsolder the dummy resistor near J-2. See adjustment locations 1. This isolates the Timing board.
3. Unsolder L897 from rear of Trigger board (see Fig. 8-6). This isolates the Trigger board.
4. Pull P4400 from the Vertical Output Amplifier board. This isolates the Vertical Output Amplifier board.
5. Pull P1200 from the Interface board (see Fig. 8-7). This isolates the Horizontal Position and Fine controls.
6. Check C1220 for a short or leakage.



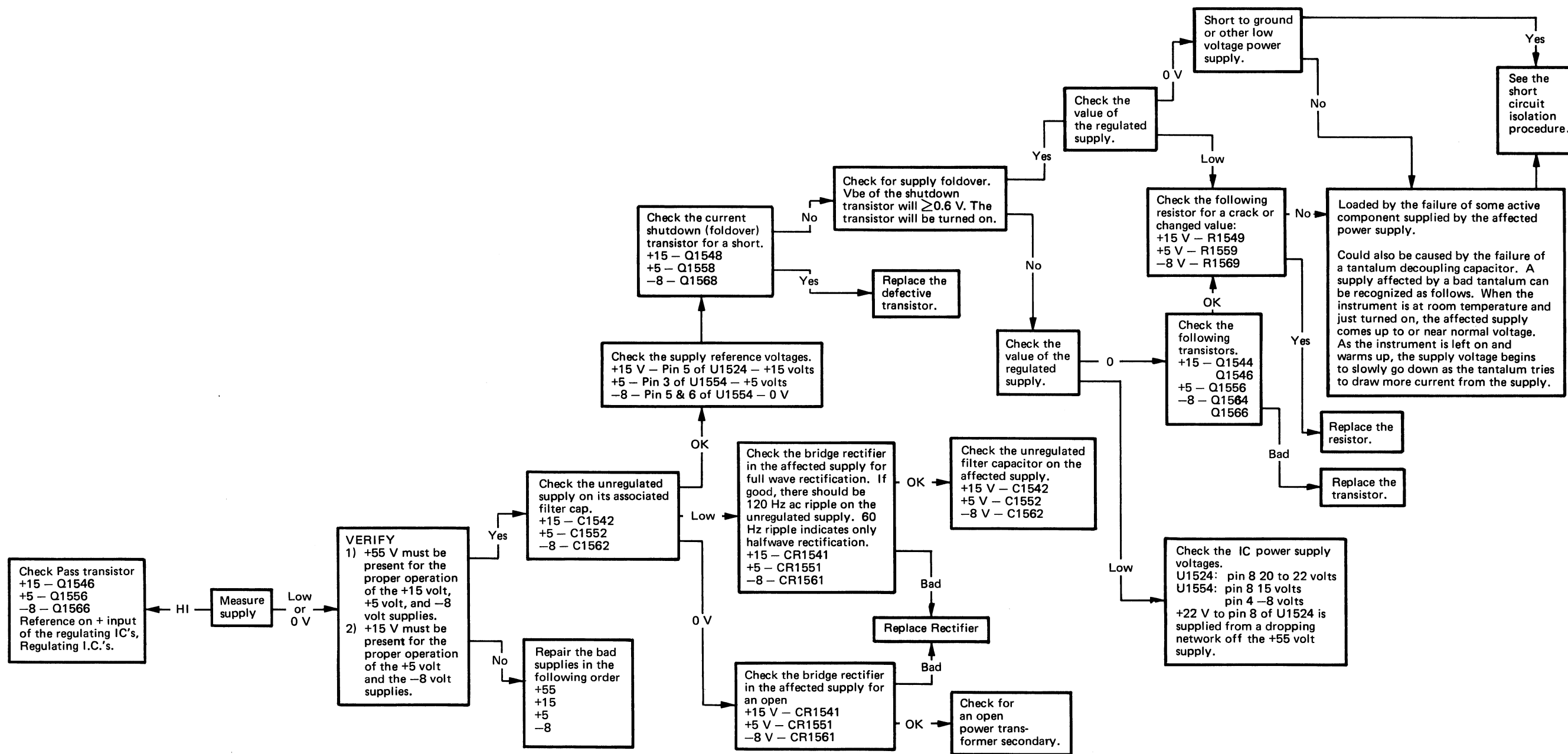

110 VOLT SUPPLY ISOLATION PROCEDURE

The following procedure is used as an aid in localizing the area in which loading of a power supply occurs. If the power supply comes up after isolating a circuit, it is very probable the problem is in that circuit. This can sometimes, however, lead to erroneous conclusions as a supply may pass through one circuit to another circuit. For instance, the +5 volt supply enters the timing board through P2-4. It then passes through the timing switch (in the X-Y position only) and P1-10 to CR1202 in the horizontal amplifier circuit. From P1-10 it also passes through P5-4 to the sweep control IC on the trigger board. Watch for these types of conditions when trying to localize a loading problem.

1. Unsolder one end of VR1289, R1282, R1262, R1229 (see Fig. 8-7). This isolates the horizontal amplifier circuit.
2. Unsolder one end of R1476 and CR1476 (see Fig. 8-7). If loading still exists, check adjustment of R1442 and R1445. If either does not adjust and an internal short is suspected, it will be necessary to remove the Interface board from the instrument before removing R1442 or R1445 from the board. This isolates the CRT circuit (Z-Axis amplifier).



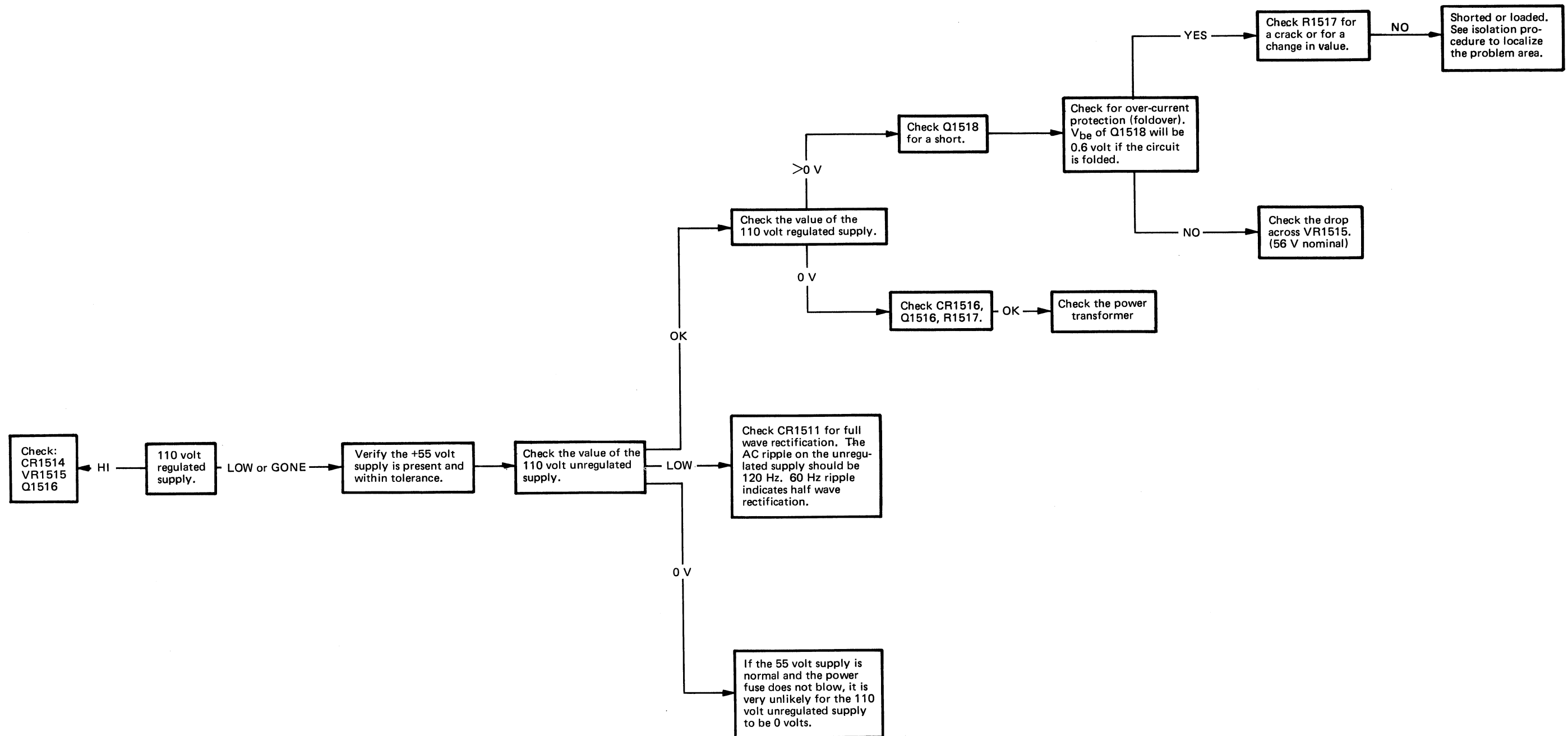

+110 VOLT SUPPLY TROUBLESHOOTING

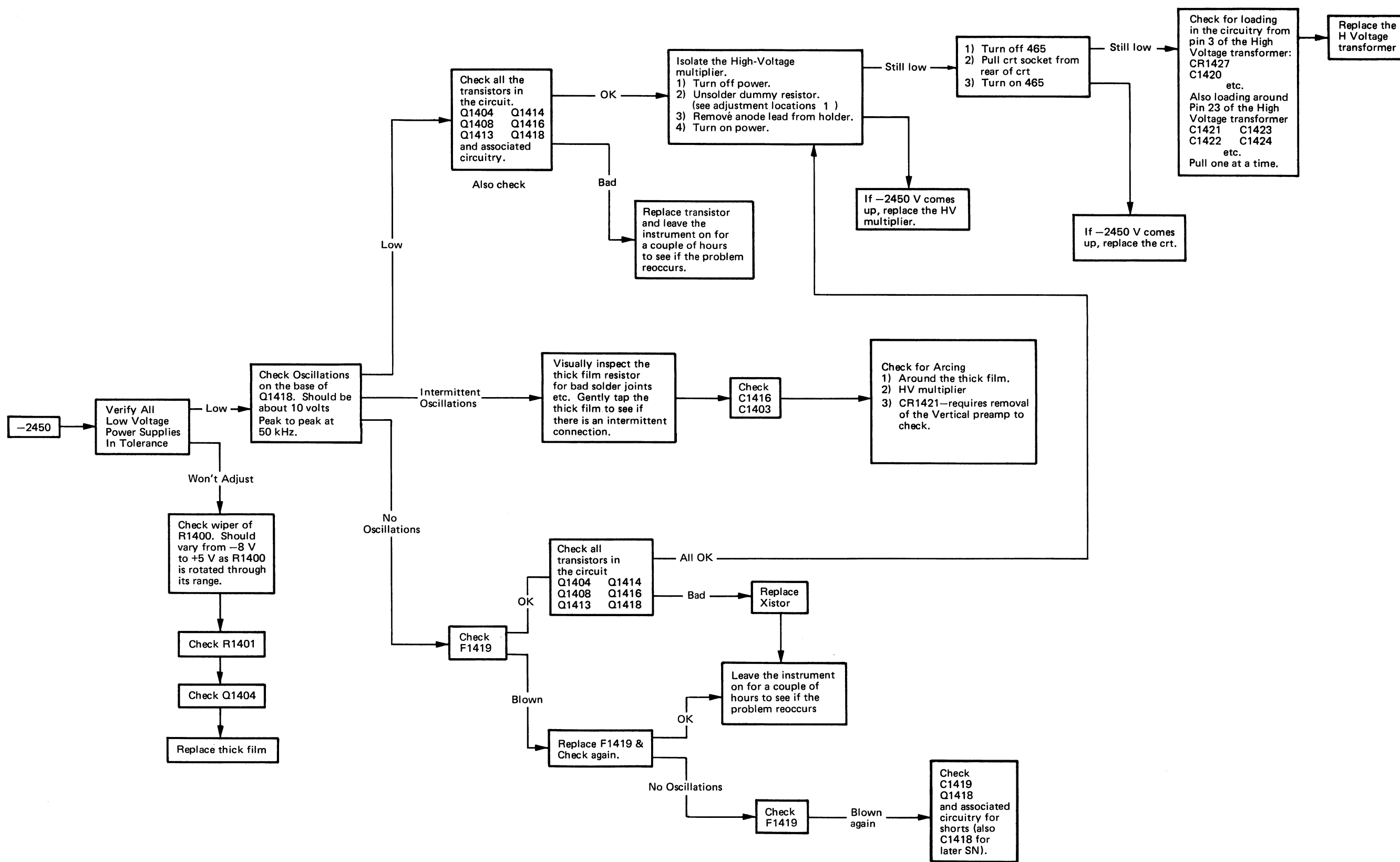

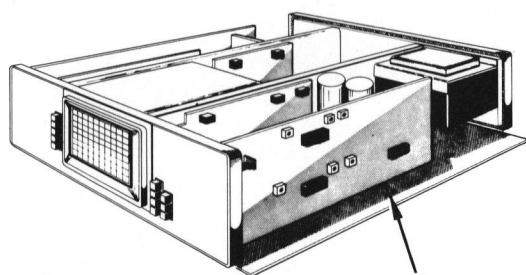

A9
INTERFACE
CIRCUIT BOARD



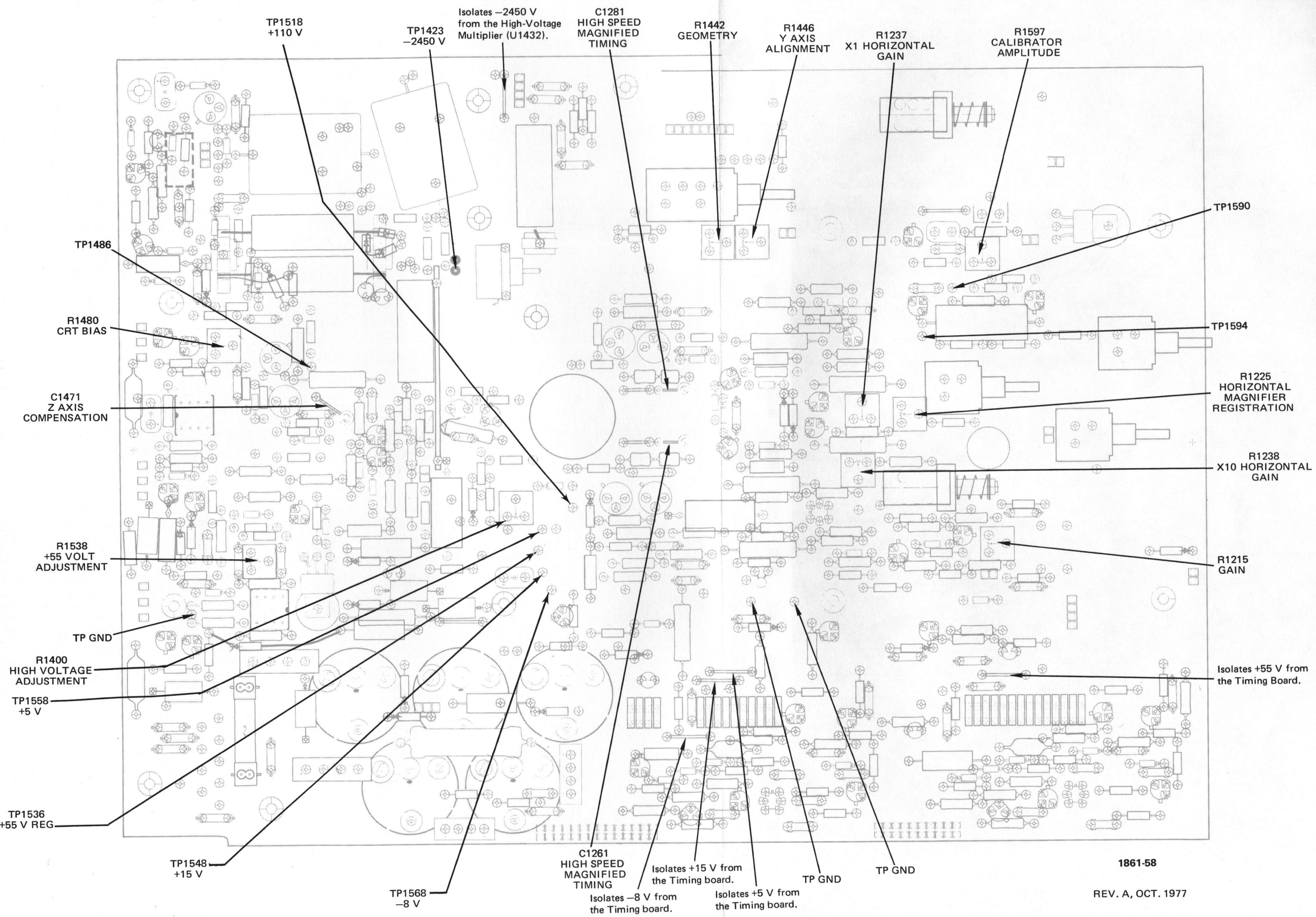

1861-58
REV. A, OCT. 1977

Fig. 8-12. Interface circuit board adjustment locations.

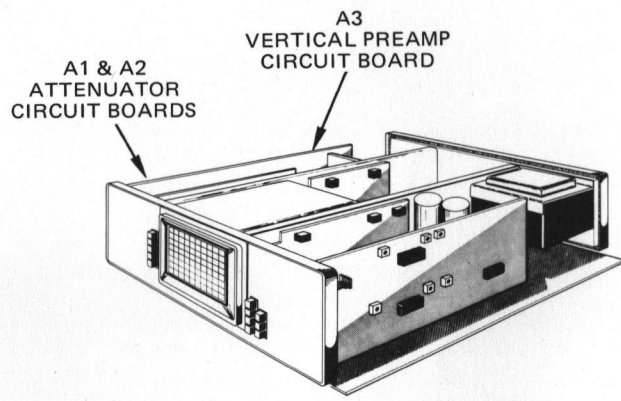

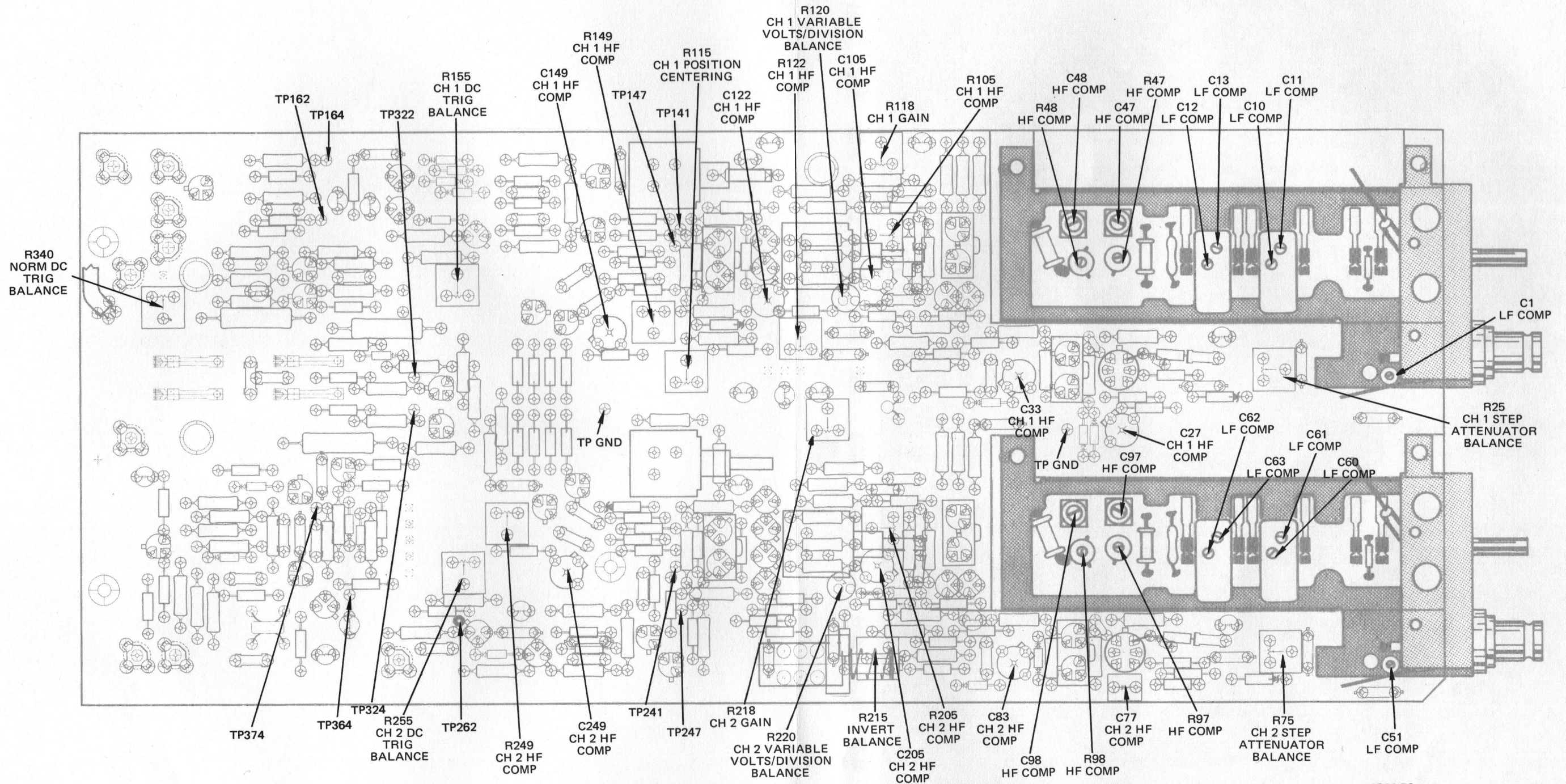

Fig. 8-13. Vertical Preamplifier and Attenuator circuit board adjustment locations.

1861-59

ADJUSTMENT LOCATIONS 2

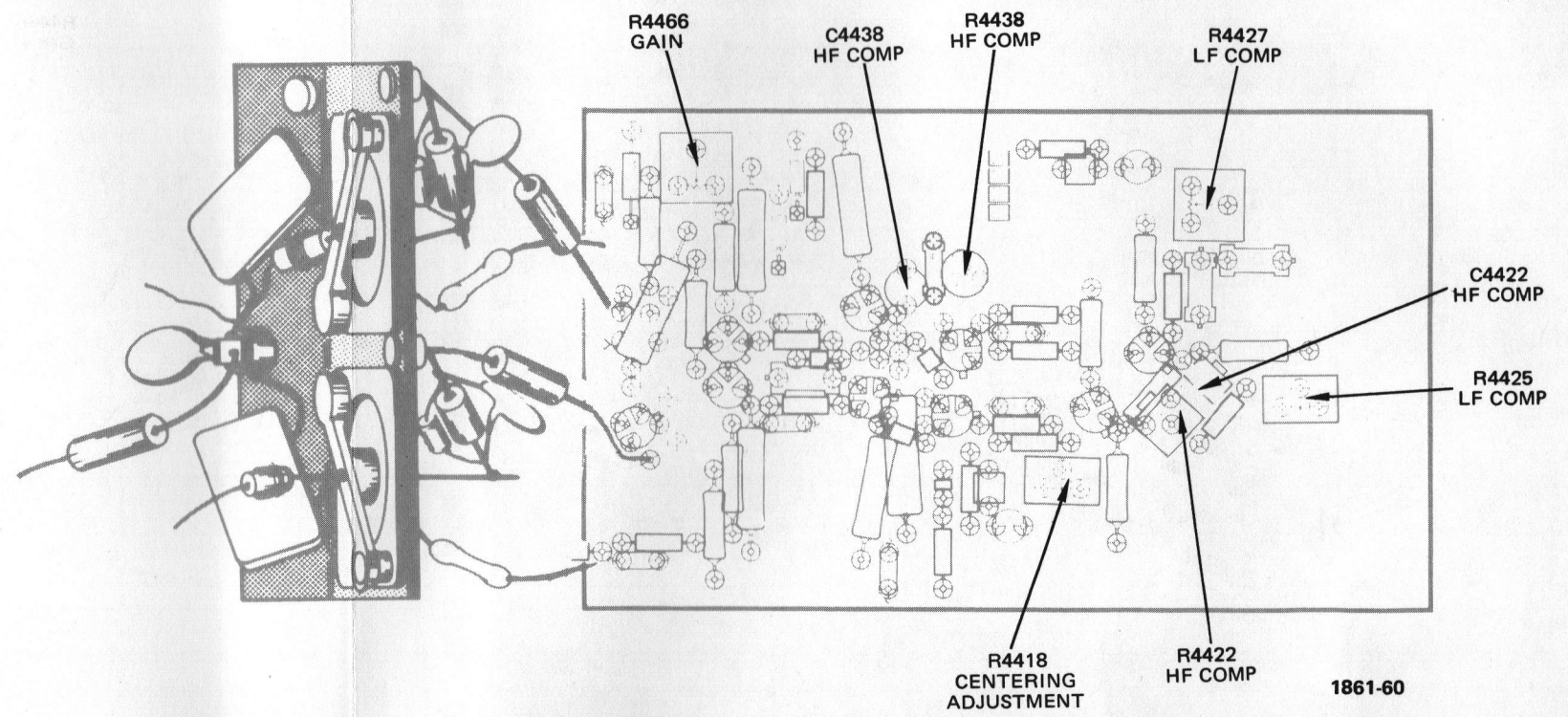
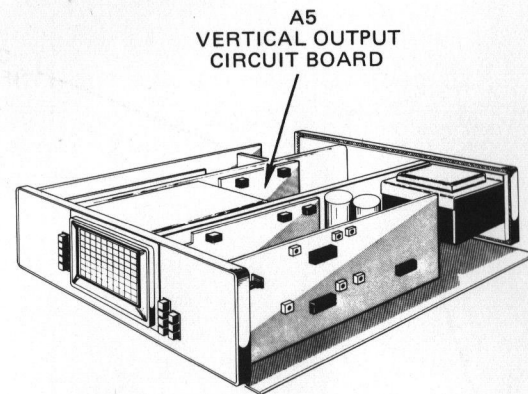

Fig. 8-14. Vertical Output Amplifier circuit board adjustment locations (discrete version).

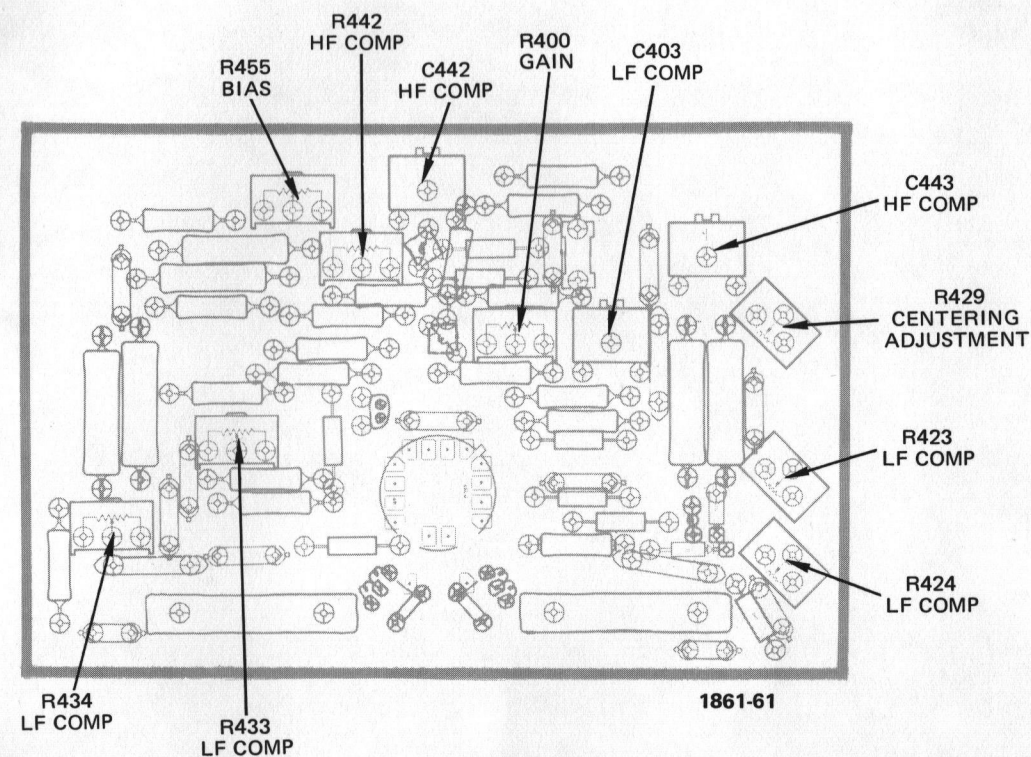
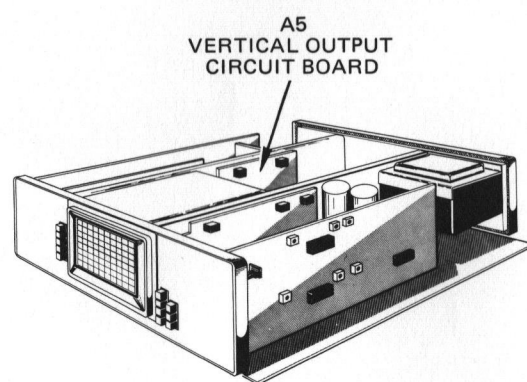
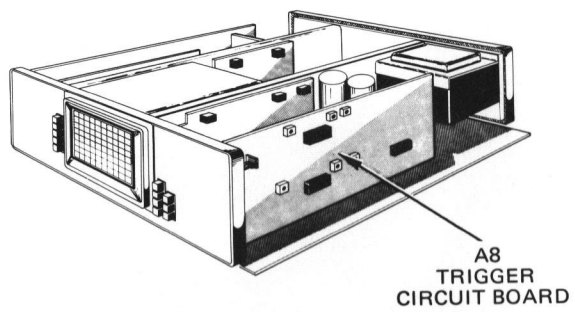

Fig. 8-15. Vertical Output Amplifier circuit board adjustment locations (IC version).



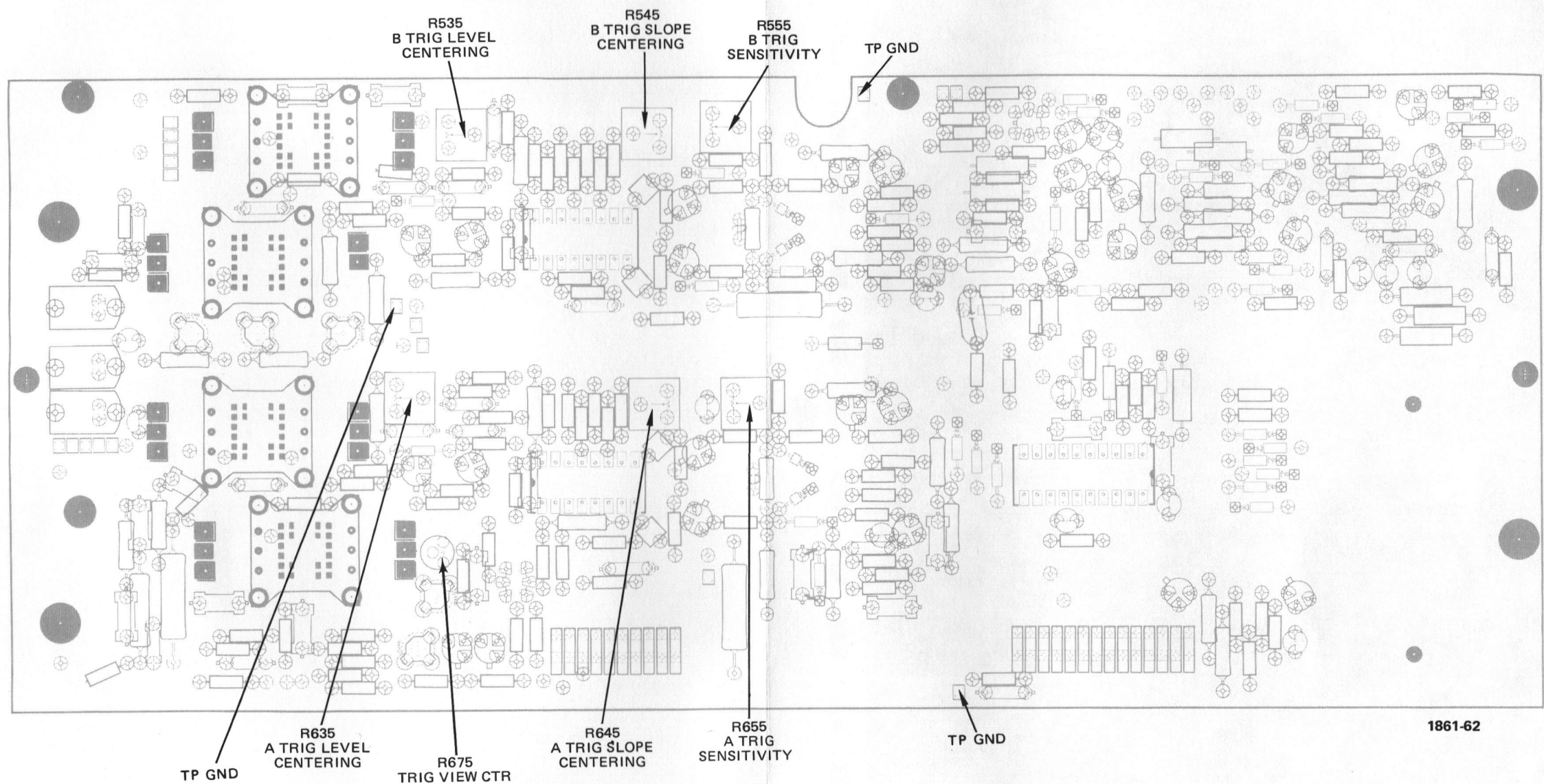

Fig. 8-16. Trigger Generator and Sweep Logic circuit board adjustment locations.

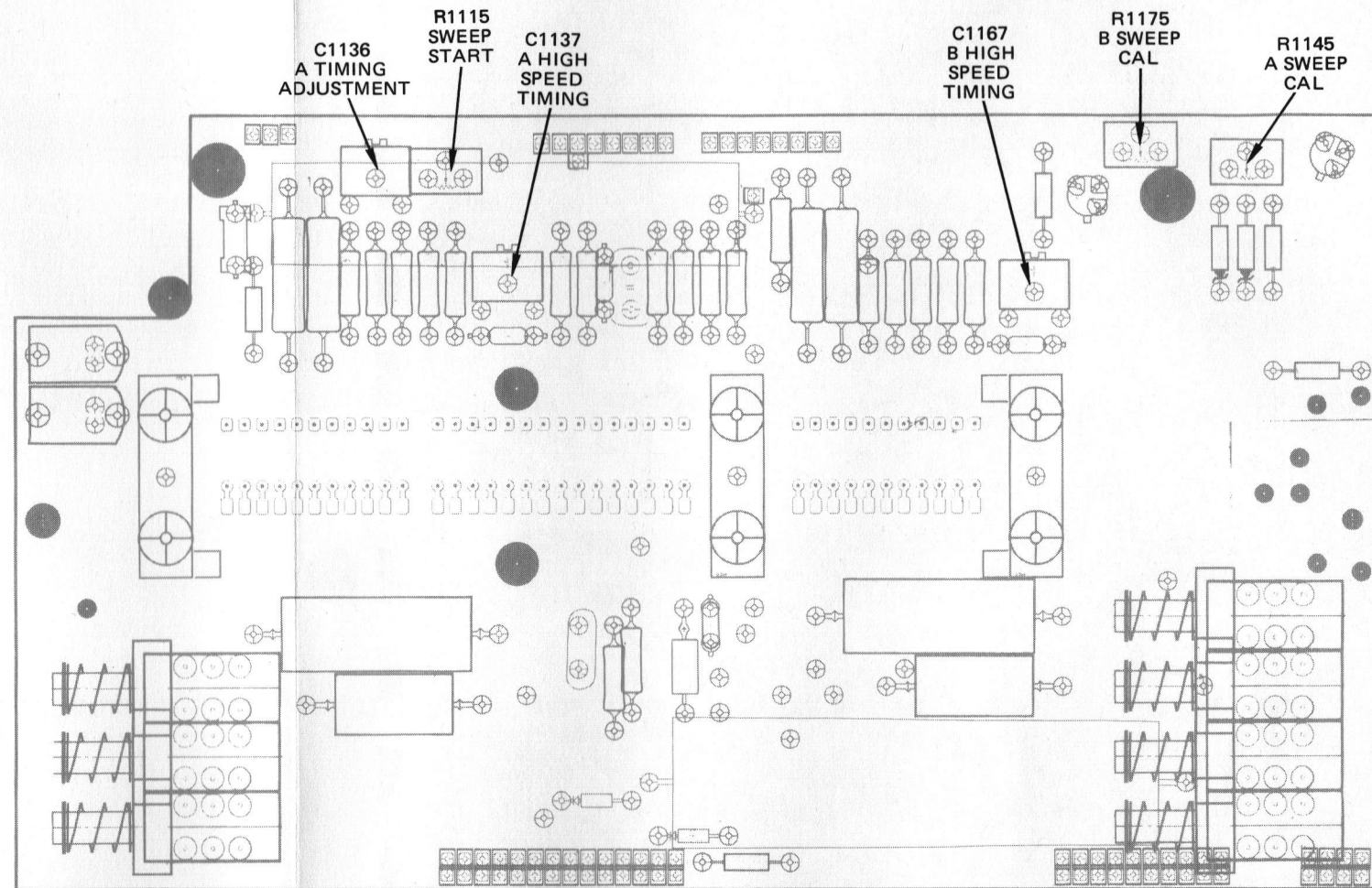
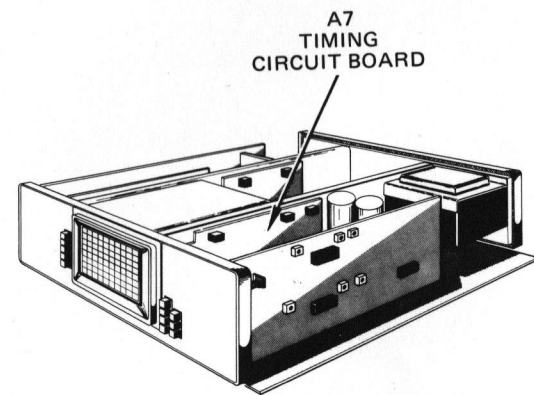

Fig. 8-17. Timing circuit board adjustment locations.

1861-63

ADJUSTMENT LOCATIONS 5

REPLACEABLE MECHANICAL PARTS

PARTS ORDERING INFORMATION

Replacement parts are available from or through your local Tektronix, Inc. Field Office or representative.

Changes to Tektronix instruments are sometimes made to accommodate improved components as they become available, and to give you the benefit of the latest circuit improvements developed in our engineering department. It is therefore important, when ordering parts, to include the following information in your order: Part number, instrument type or number, serial number, and modification number if applicable.

If a part you have ordered has been replaced with a new or improved part, your local Tektronix, Inc. Field Office or representative will contact you concerning any change in part number.

Change information, if any, is located at the rear of this manual.

SPECIAL NOTES AND SYMBOLS

- X000 Part first added at this serial number
- 00X Part removed after this serial number

FIGURE AND INDEX NUMBERS

Items in this section are referenced by figure and index numbers to the illustrations.

INDENTATION SYSTEM

This mechanical parts list is indented to indicate item relationships. Following is an example of the indentation system used in the description column.

- ```

1 2 3 4 5 Name & Description
Assembly and/or Component
Attaching parts for Assembly and/or Component
 ---*---
Detail Part of Assembly and/or Component
Attaching parts for Detail Part
 ---*---
Parts of Detail Part
Attaching parts for Parts of Detail Part
 ---*---

```

Attaching Parts always appear in the same indentation as the item it mounts, while the detail parts are indented to the right. Indented items are part of, and included with, the next higher indentation. The separation symbol ---\*--- indicates the end of attaching parts.

**Attaching parts must be purchased separately, unless otherwise specified.**

## ITEM NAME

In the Parts List, an Item Name is separated from the description by a colon (:). Because of space limitations, an Item Name may sometimes appear as incomplete. For further Item Name identification, the U.S. Federal Cataloging Handbook H6-1 can be utilized where possible.

## ABBREVIATIONS

|       |                    |         |                       |          |                      |         |                 |
|-------|--------------------|---------|-----------------------|----------|----------------------|---------|-----------------|
| #     | INCH NUMBER SIZE   | ELCTRN  | ELECTRON              | IN       | INCH                 | SE      | SINGLE END      |
| ACTR  | ACTUATOR           | ELEC    | ELECTRICAL            | INCAND   | INCANDESCENT         | SECT    | SECTION         |
| ADPTR | ADAPTER            | ELCTLT  | ELECTROLYTIC          | INSUL    | INSULATOR            | SEMICON | SEMICONDUCTOR   |
| ALIGN | ALIGNMENT          | ELEM    | ELEMENT               | INTL     | INTERNAL             | SHLD    | SHIELD          |
| AL    | ALUMINUM           | EPL     | ELECTRICAL PARTS LIST | LPHLDR   | LAMPHOLDER           | SHLDR   | SHOULDERED      |
| ASSEM | ASSEMBLED          | EQPT    | EQUIPMENT             | MACH     | MACHINE              | SKT     | SOCKET          |
| ASSY  | ASSEMBLY           | EXT     | EXTERNAL              | MECH     | MECHANICAL           | SL      | SLIDE           |
| ATTEN | ATTENUATOR         | FIL     | FILLISTER HEAD        | MTG      | MOUNTING             | SLFLKG  | SELF-LOCKING    |
| AWG   | AMERICAN WIRE GAGE | FLEX    | FLEXIBLE              | NIP      | NIPPLE               | SLVG    | SLEEVEING       |
| BD    | BOARD              | FLH     | FLAT HEAD             | NON WIRE | NOT WIRE WOUND       | SPR     | SPRING          |
| BRKT  | BRACKET            | FLTR    | FILTER                | OBD      | ORDER BY DESCRIPTION | SQ      | SQUARE          |
| BRS   | BRASS              | FR      | FRAME or FRONT        | OD       | OUTSIDE DIAMETER     | SST     | STAINLESS STEEL |
| BRZ   | BRONZE             | FSTNR   | FASTENER              | OVH      | OVAL HEAD            | STL     | STEEL           |
| BSHG  | BUSHING            | FT      | FOOT                  | PH BRZ   | PHOSPHOR BRONZE      | SW      | SWITCH          |
| CAB   | CABINET            | FXD     | FIXED                 | PL       | PLAIN or PLATE       | T       | TUBE            |
| CAP   | CAPACITOR          | GSKT    | GASKET                | PLSTC    | PLASTIC              | TERM    | TERMINAL        |
| CER   | CERAMIC            | HDL     | HANDLE                | PN       | PART NUMBER          | THD     | THREAD          |
| CHAS  | CHASSIS            | HEX     | HEXAGON               | PNH      | PAN HEAD             | THK     | THICK           |
| CKT   | CIRCUIT            | HEX HD  | HEXAGONAL HEAD        | PWR      | POWER                | TNSN    | TENSION         |
| COMP  | COMPOSITION        | HEX SOC | HEXAGONAL SOCKET      | RCPT     | RECEPTACLE           | TPG     | TAPPING         |
| CONN  | CONNECTOR          | HLCPS   | HELICAL COMPRESSION   | RES      | RESISTOR             | TRH     | TRUSS HEAD      |
| COV   | COVER              | HLEXT   | HELICAL EXTENSION     | RGD      | RIGID                | V       | VOLTAGE         |
| CPLG  | COUPLING           | HV      | HIGH VOLTAGE          | RLF      | RELIEF               | VAR     | VARIABLE        |
| CRT   | CATHODE RAY TUBE   | IC      | INTEGRATED CIRCUIT    | RTNR     | RETAINER             | W/      | WITH            |
| DEG   | DEGREE             | ID      | INSIDE DIAMETER       | SCH      | SOCKET HEAD          | WSHR    | WASHER          |
| DWR   | DRAWER             | IDENT   | IDENTIFICATION        | SCOPE    | OSCILLOSCOPE         | XFMR    | TRANSFORMER     |
|       |                    | IMPLR   | IMPELLER              | SCR      | SCREW                | XSTR    | TRANSISTOR      |



CROSS INDEX—MFR. CODE NUMBER TO MANUFACTURER

| Mfr. Code | Manufacturer                                                | Address                                  | City, State, Zip            |
|-----------|-------------------------------------------------------------|------------------------------------------|-----------------------------|
| 00779     | AMP, INC.                                                   | P O BOX 3608                             | HARRISBURG, PA 17105        |
| 01295     | TEXAS INSTRUMENTS, INC., SEMICONDUCTOR GROUP                | P O BOX 5012, 13500 N CENTRAL EXPRESSWAY | DALLAS, TX 75222            |
| 01963     | CHERRY ELECTRICAL PRODUCTS CORPORATION                      | 3600 SUNSET AVENUE                       | WAUKEGAN, IL 60085          |
| 05006     | TWENTIETH CENTURY PLASTICS, INC.                            | 415 E WASHINGTON BLVD.                   | LOS ANGELES, CA 90015       |
| 05129     | KILO ENGINEERING COMPANY                                    | 2015 D                                   | LA VERNE, CA 91750          |
| 06540     | AMATOM ELECTRONIC HARDWARE, DIV. OF MITE CORP.              | 446 BLAKE ST.                            | NEW HAVEN, CT 06515         |
| 06666     | GENERAL DEVICES CO., INC.                                   | 525 S. WEBSTER AVE.                      | INDIANAPOLIS, IN 46219      |
| 07700     | TECHNICAL WIRE AND PRODUCTS, INC.                           | 129 DERMODY ST.                          | CRANFORD, NJ 07016          |
| 08261     | SPECTRA-STRIP CORP.                                         | 7100 LAMPSON AVE.                        | GARDEN GROVE, CA 92642      |
| 08530     | RELIANCE MICA CORP.                                         | 342-39TH ST.                             | BROOKLYN, NY 11232          |
| 09353     | C AND K COMPONENTS, INC.                                    | 103 MORSE STREET                         | WATERTOWN, MA 02172         |
| 12327     | FREEWAY CORPORATION                                         | 9301 ALLEN DRIVE                         | CLEVELAND, OH 44125         |
| 12360     | ALBANY PRODUCTS CO., DIV. OF PNEUMO DYNAMICS CORPORATION    | 145 WOODWARD AVENUE                      | SOUTH NORWALK, CT 06586     |
| 14438     | USM CORP., NYLOK FASTENER DIV.                              | 3730 W. MORSE                            | LINCOLNWOOD, IL 60645       |
| 22526     | BERG ELECTRONICS, INC.                                      | YOUK EXPRESSWAY                          | NEW CUMBERLAND, PA 17070    |
| 23050     | PRODUCT COMPONENTS CORP                                     | 30 LORRAINE AVE.                         | MT VERNON, NY 10553         |
| 24011     | ELECTRONIZED CHEMICALS CORPORATION                          | S BEDFORD STREET                         | BURLINGTON, MA 01803        |
| 24931     | SPECIALTY CONNECTOR CO., INC.                               | 3560 MADISON AVE.                        | INDIANAPOLIS, IN 46227      |
| 28817     | CAL-METEX CORP., SUBSIDIARY OF METEX CORP.                  | 509 HINDRY AVE.                          | INGLEWOOD, CA 90301         |
| 42838     | NATIONAL RIVET AND MFG. CO.                                 | 1-21 EAST JEFFERSON ST.                  | WAUPUN, WI 53963            |
| 51316     | ANGELUS WASHER AND STAMPING CO.                             | 1411 ESPERANZA ST.                       | LOS ANGELES, CA 90023       |
| 55210     | GETTIG ENG. AND MFG. COMPANY                                | PO BOX 85, OFF ROUTE 45                  | SPRING MILLS, PA 16875      |
| 56878     | STANDARD PRESSED STEEL COMPANY                              | BENSON EAST                              | JENKINTOWN, PA 19046        |
| 63743     | WARD LEONARD ELECTRIC CO., INC.                             | 31 SOUTH ST.                             | MOUNT VERNON, NY 10550      |
| 70276     | ALLEN MFG. CO.                                              | P. O. DRAWER 570                         | HARTFORD, CT 06101          |
| 70278     | ALLIED STEEL AND CONVEYORS, DIV. OF SPARTON CORP.           | 17333 HEALY                              | DETROIT, MI 48212           |
| 70485     | ATLANTIC INDIA RUBBER WORKS, INC.                           | 571 W. POLK ST.                          | CHICAGO, IL 60607           |
| 71279     | CAMBRIDGE THERMIONIC CORP.                                  | 445 CONCORD AVE.                         | CAMBRIDGE, MA 02138         |
| 71400     | BUSSMAN MFG., DIVISION OF MCGRAW-EDISON CO.                 | 2536 W. UNIVERSITY ST.                   | ST. LOUIS, MO 63107         |
| 71590     | CENTRALAB ELECTRONICS, DIV. OF GLOBE-UNION, INC.            | P O BOX 858                              | FORT DODGE, IA 50501        |
| 71785     | TRW, CINCH CONNECTORS                                       | 1501 MORSE AVENUE                        | ELK GROVE VILLAGE, IL 60007 |
| 72228     | CONTINENTAL SCREW CO., DIV. OF AMTEL, INC.                  | 459 MT. PLEASANT                         | NEW BEDFORD, MA 02742       |
| 73743     | FISCHER SPECIAL MFG. CO.                                    | 446 MORGAN ST.                           | CINCINNATI, OH 45206        |
| 73803     | TEXAS INSTRUMENTS, INC., METALLURGICAL MATERIALS DIV.       | 34 FOREST STREET                         | ATTLEBORO, MA 02703         |
| 74445     | HOLO-KROME CO.                                              | 31 BROOK ST. WEST                        | HARTFORD, CT 06110          |
| 75497     | LAMSON AND SESSIONS CO., THE                                | 5000 TIEDEMAN ROAD                       | CLEVELAND, OH 44144         |
| 75915     | LITTELFUSE, INC.                                            | 800 E. NORTHWEST HWY                     | DES PLAINES, IL 60016       |
| 77250     | PHEOLL MANUFACTURING CO., DIVISION OF ALLIED PRODUCTS CORP. | 5700 W. ROOSEVELT RD.                    | CHICAGO, IL 60650           |
| 78189     | ILLINOIS TOOL WORKS, INC. SHAKEPROOF DIVISION               | ST. CHARLES ROAD                         | ELGIN, IL 60120             |
| 79136     | WALDES, KOHINOOR, INC.                                      | 47-16 AUSTEL PLACE                       | LONG ISLAND CITY, NY 11101  |
| 79807     | WROUGHT WASHER MFG. CO.                                     | 2100 S. O BAY ST.                        | MILWAUKEE, WI 53207         |
| 80009     | TEKTRONIX, INC.                                             | P O BOX 500                              | BEAVERTON, OR 97077         |
| 83385     | CENTRAL SCREW CO.                                           | 2530 CRESCENT DR.                        | BROADVIEW, IL 60153         |
| 86445     | PENN FIBRE AND SPECIALTY CO., INC.                          | 2032 E. WESTMORELAND ST.                 | PHILADELPHIA, PA 19134      |
| 86928     | SEASTROM MFG. COMPANY, INC.                                 | 701 SONORA AVENUE                        | GLENDALE, CA 91201          |
| 88245     | LITTON SYSTEMS, INC., USECO DIV.                            | 13536 SATICOY ST.                        | VAN NUYS, CA 91409          |
| 93410     | ESSEX INTERNATIONAL, INC., CONTROLS DIV. LEXINGTON PLANT    | P. O. BOX 1007                           | MANSFIELD, OH 44903         |
| 97464     | INDUSTRIAL RETAINING RING CO.                               | 57 CORDIER ST.                           | IRVINGTON, NJ 07111         |
| 98278     | MALCO A MICRODOT COMPANY, INC. CONNECTOR AND CABLE DIVISION | 220 PASADENA AVE.                        | SOUTH PASADENA, CA 91030    |

Replaceable Mechanical Parts—465 Service (SN B250000-up)

| Fig. & Index No. | Tektronix Part No. | Serial/Model No. Eff | Dscont  | Qty | 1 | 2 | 3 | 4 | 5 | Name & Description                                                         | Mfr Code | Mfr Part Number |
|------------------|--------------------|----------------------|---------|-----|---|---|---|---|---|----------------------------------------------------------------------------|----------|-----------------|
| 1-1              | 200-1411-00        |                      |         | 1   |   |   |   |   |   | BEZEL,CRT:                                                                 | 80009    | 200-1411-00     |
| -2               | 213-0313-00        |                      |         | 4   |   |   |   |   |   | . THUMBSCREW:4-40 X 0.45 INCH,KNURLED                                      | 80009    | 213-0313-00     |
| -3               | 337-1674-00        |                      |         | 1   |   |   |   |   |   | SHLD,ELCTR N TUB:CRT                                                       | 80009    | 337-1674-00     |
| -4               | 366-0494-00        |                      |         | 2   |   |   |   |   |   | KNOB:GRAY                                                                  | 80009    | 366-0494-00     |
|                  | 213-0153-00        |                      |         | 1   |   |   |   |   |   | . SETSCREW:5-40 X 0.125 INCH,HEX SOC STL                                   | 74445    | OBD             |
| -5               | 366-1031-02        |                      |         | 2   |   |   |   |   |   | KNOB:RED-VAR                                                               | 80009    | 366-1031-02     |
|                  | 213-0153-00        |                      |         | 1   |   |   |   |   |   | . SETSCREW:5-40 X 0.125 INCH,HEX SOC STL                                   | 74445    | OBD             |
| -6               | 366-1426-00        |                      |         | 2   |   |   |   |   |   | KNOB:GRAY                                                                  | 80009    | 366-1426-00     |
|                  | 213-0153-00        |                      |         | 1   |   |   |   |   |   | . SETSCREW:5-40 X 0.125 INCH,HEX SOC STL                                   | 74445    | OBD             |
| -7               | 366-0215-02        |                      |         | 2   |   |   |   |   |   | KNOB:LEVER SWITCH                                                          | 80009    | 366-0215-02     |
| -8               | 366-1402-31        |                      |         | 1   |   |   |   |   |   | PUSH BUTTON:GRAY--INVERT                                                   | 80009    | 366-1402-31     |
| -9               | 366-1402-42        |                      |         | 1   |   |   |   |   |   | PUSH BUTTON:--BEAM FINDER                                                  | 80009    | 366-1402-42     |
| -10              | 366-1257-20        |                      |         | 1   |   |   |   |   |   | PUSH BUTTON:GRAY--CH2                                                      | 80009    | 366-1257-20     |
| -11              | 366-1402-37        |                      |         | 1   |   |   |   |   |   | PUSH BUTTON:GRAY--CHOP                                                     | 80009    | 366-1402-37     |
| -12              | 366-1257-16        |                      |         | 1   |   |   |   |   |   | PUSH BUTTON:GRAY--ADD                                                      | 80009    | 366-1257-16     |
| -13              | 366-1402-36        |                      |         | 1   |   |   |   |   |   | PUSH BUTTON:GRAY--ALT                                                      | 80009    | 366-1402-36     |
| -14              | 366-1257-19        |                      |         | 1   |   |   |   |   |   | PUSH BUTTON:GRAY--CH1                                                      | 80009    | 366-1257-19     |
| -15              | 366-1023-01        |                      |         | 3   |   |   |   |   |   | KNOB:GRAY                                                                  | 80009    | 366-1023-01     |
|                  | 213-0153-00        |                      |         | 1   |   |   |   |   |   | . SETSCREW:5-40 X 0.125 INCH,HEX SOC STL                                   | 74445    | OBD             |
| -16              | 366-1402-33        |                      |         | 1   |   |   |   |   |   | PUSH BUTTON:GRAY--X10                                                      | 80009    | 366-1402-33     |
| -17              | 366-1327-00        |                      |         | 1   |   |   |   |   |   | KNOB:GRAY                                                                  | 80009    | 366-1327-00     |
|                  | 213-0153-00        |                      |         | 1   |   |   |   |   |   | . SETSCREW:5-40 X 0.125 INCH,HEX SOC STL                                   | 74445    | OBD             |
| -18              | 366-1280-00        |                      |         | 1   |   |   |   |   |   | KNOB:GRAY                                                                  | 80009    | 366-1278-00     |
|                  | 213-0153-00        |                      |         | 1   |   |   |   |   |   | . SETSCREW:5-40 X 0.125 INCH,HEX SOC STL                                   | 74445    | OBD             |
| -19              | 366-1402-35        |                      |         | 1   |   |   |   |   |   | PUSH BUTTON:GRAY--B DLY'D                                                  | 80009    | 366-1402-35     |
| -20              | 366-1402-44        |                      |         | 1   |   |   |   |   |   | PUSH BUTTON:GRAY--A INTEN                                                  | 80009    | 366-1402-44     |
| -21              | 366-1402-29        |                      |         | 1   |   |   |   |   |   | PUSH BUTTON:GRAY--MIX                                                      | 80009    | 366-1402-29     |
| -22              | 366-1489-36        |                      |         | 1   |   |   |   |   |   | PUSH BUTTON:GRAY--A LOCK KNOBS                                             | 80009    | 366-1489-36     |
| -23              | 366-1257-29        |                      |         | 1   |   |   |   |   |   | PUSH BUTTON:GRAY--SNGL SWP                                                 | 80009    | 366-1257-29     |
| -24              | 366-1402-39        |                      |         | 1   |   |   |   |   |   | PUSH BUTTON:GRAY--NORM                                                     | 80009    | 366-1402-39     |
| -25              | 366-1402-38        |                      |         | 1   |   |   |   |   |   | PUSH BUTTON:GRAY--AUTO                                                     | 80009    | 366-1402-38     |
| -26              | 331-0328-00        |                      |         | 1   |   |   |   |   |   | DIAL,CONTROL:10 TURN FOR 0.25 DIA SHAFT                                    | 05129    | 461-S-70        |
|                  | 213-0048-00        |                      |         | 1   |   |   |   |   |   | . SETSCREW:4-40 X 0.125 INCH,HEX SOC STL                                   | 74445    | OBD             |
| -27              | 366-1346-02        |                      |         | 1   |   |   |   |   |   | KNOB:RED                                                                   | 80009    | 366-1346-00     |
|                  | 213-0153-00        |                      |         | 1   |   |   |   |   |   | . SETSCREW:5-40 X 0.125 INCH,HEX SOC STL                                   | 74445    | OBD             |
| -28              | 366-1219-01        |                      |         | 1   |   |   |   |   |   | KNOB:GRAY--DLYD SWP                                                        | 80009    | 366-1219-01     |
|                  | 213-0153-00        |                      |         | 2   |   |   |   |   |   | . SETSCREW:5-40 X 0.125 INCH,HEX SOC STL                                   | 74445    | OBD             |
| -29              | 354-0442-01        |                      |         | 1   |   |   |   |   |   | RING,KNOB SKIRT:PLASTIC,1.45 INCH DIA                                      | 80009    | 354-0442-01     |
|                  | 213-0005-00        |                      |         | 1   |   |   |   |   |   | . SETSCREW:8-32 X 1.25 INCH,HEX SOC STL                                    | 74445    | OBD             |
| -30              | 401-0080-00        |                      |         | 1   |   |   |   |   |   | BRG,KNOB SKIRT:0.789 ID X 0.866"OD PLASTIC                                 | 80009    | 401-0080-00     |
| -31              | 366-0494-00        |                      |         | 1   |   |   |   |   |   | KNOB:GRAY                                                                  | 80009    | 366-0494-00     |
|                  | 213-0153-00        |                      |         | 1   |   |   |   |   |   | . SETSCREW:5-40 X 0.125 INCH,HEX SOC STL                                   | 74445    | OBD             |
| -32              | 366-1278-00        |                      |         | 2   |   |   |   |   |   | KNOB:GRAY                                                                  | 80009    | 366-1278-00     |
|                  | 213-0153-00        |                      |         | 1   |   |   |   |   |   | . SETSCREW:5-40 X 0.125 INCH,HEX SOC STL                                   | 74445    | OBD             |
| -33              | 366-1280-00        |                      |         | 2   |   |   |   |   |   | KNOB:GRAY                                                                  | 80009    | 366-1278-00     |
|                  | 213-0153-00        |                      |         | 1   |   |   |   |   |   | . SETSCREW:5-40 X 0.125 INCH,HEX SOC STL                                   | 74445    | OBD             |
| -34              | 358-0378-01        | B250000              | B252904 | 14  |   |   |   |   |   | BUSHING,SLEEVE:0.250 OD X 0.131 ID,PRESS MT                                | 80009    | 358-0378-01     |
|                  | 358-0378-01        | B252905              |         | 12  |   |   |   |   |   | BUSHING,SLEEVE:0.250 OD X 0.131 ID,PRESS MT                                | 80009    | 358-0378-01     |
|                  | 358-0540-00        | B252905              |         | 2   |   |   |   |   |   | BSHG,MACH.THD:0.25-32 X 0.128 ID X 0.24" L<br>(ATTACHING PARTS FOR EACH)   | 80009    | 358-0540-00     |
|                  | 210-0583-00        | B252905              |         | 1   |   |   |   |   |   | NUT,PLAIN,HEX.:0.25-32 X 0.312 INCH,BRS                                    | 73743    | 2X20224-402     |
|                  | 210-0940-00        | B252905              |         | 1   |   |   |   |   |   | WASHER,FLAT:0.25 ID X 0.375 INCH OD,STL                                    | 79807    | OBD             |
|                  |                    |                      |         |     |   |   |   |   |   | - - - * - - -                                                              |          |                 |
| -35              | 358-0216-01        |                      |         | 2   |   |   |   |   |   | BUSHING,PLASTIC:0.257 ID X 0.412 INCH OD                                   | 80009    | 358-0216-01     |
| -36              | 426-0681-01        |                      |         | 16  |   |   |   |   |   | FR,PUSH BUTTON:GRAY PLASTIC                                                | 80009    | 426-0681-01     |
| -37              | 378-0803-01        |                      |         | 2   |   |   |   |   |   | LENS,LIGHT:CLEAR,ATTENUATOR                                                | 80009    | 378-0803-01     |
| -38              | 378-0803-00        |                      |         | 5   |   |   |   |   |   | LENS,LIGHT:CLEAR                                                           | 80009    | 378-0803-00     |
| -39              | 358-0216-00        |                      |         | 1   |   |   |   |   |   | BUSHING,PLASTIC:0.257 ID X 0.412 INCH OD                                   | 80009    | 358-0216-00     |
| -40              | -----              |                      |         | 4   |   |   |   |   |   | RES.,VAR,NONWIR:(SEE R530,630,1155,1205 EPL)<br>(ATTACHING PARTS FOR EACH) |          |                 |
| -41              | 210-0583-00        |                      |         | 1   |   |   |   |   |   | NUT,PLAIN,HEX.:0.25-32 X 0.312 INCH,BRS                                    | 73743    | 2X20224-402     |
| -42              | 210-0940-00        |                      |         | 1   |   |   |   |   |   | WASHER,FLAT:0.25 ID X 0.375 INCH OD,STL                                    | 79807    | OBD             |
|                  |                    |                      |         |     |   |   |   |   |   | - - - * - - -                                                              |          |                 |

Replaceable Mechanical Parts—465 Service (SN B250000-up)

| Fig. & Index No. | Tektronix Part No.       | Serial/Model No. Eff | Discont  | Qty | 1 | 2 | 3 | 4 | 5 | Name & Description                                                      | Mfr Code | Mfr Part Number  |
|------------------|--------------------------|----------------------|----------|-----|---|---|---|---|---|-------------------------------------------------------------------------|----------|------------------|
| 1-43             | -----                    |                      |          | 1   |   |   |   |   |   | RES.,VAR,WW:(SEE R1110 EPL)                                             |          |                  |
| -44              | -----                    |                      |          | 2   |   |   |   |   |   | CONN,RCPT,ELEC:W/HDWR(SEE J500,600 EPL)                                 |          |                  |
| -45              | 119-0373-00              |                      |          | 1   |   |   |   |   |   | COIL,CALIBRATIO:<br>(ATTACHING PARTS)                                   | 80009    | 119-0373-00      |
| -46              | 210-0586-00              |                      |          | 2   |   |   |   |   |   | NUT,PLAIN,EXT W:4-40 X 0.25 INCH,STL                                    | 78189    | OBD              |
| -47              | 210-0851-00              |                      |          | 2   |   |   |   |   |   | WASHER,FLAT:0.119 ID X 0.375 INCH OD,STL                                | 12327    | OBD              |
| -48              | 210-0811-00              |                      |          | 2   |   |   |   |   |   | WSHR,SHOULDERED:0.125 ID X 0.50 INCH OD                                 | 86928    | 5604-47          |
| -49              | 361-0059-01              |                      |          | 1   |   |   |   |   |   | SPACER,CUR LOOP:1.094 X 0.344 X 0.125 INCH                              | 80009    | 361-0059-01      |
| -50              | 210-0593-00              |                      |          | 2   |   |   |   |   |   | NUT,FINISHING:0.25 HEX X 0.312" LONG,BRS<br>-----*                      | 80009    | 210-0593-00      |
| -51              | 378-0635-00              |                      |          | 4   |   |   |   |   |   | LENS,LIGHT:WHITE                                                        | 80009    | 378-0635-00      |
| -52              | 333-1635-00              |                      |          | 1   |   |   |   |   |   | PANEL,FRONT:                                                            | 80009    | 333-1635-00      |
| -53              | 352-0340-00              |                      |          | 2   |   |   |   |   |   | LAMPHOLDER:SCALE FACTOR<br>(ATTACHING PARTS)                            | 80009    | 352-0340-00      |
| -54              | 211-0001-00              |                      |          | 1   |   |   |   |   |   | SCREW,MACHINE:2-56 X 0.25 INCH,PNH STL<br>-----*                        | 83385    | OBD              |
|                  | 386-2330-00              | B250000              | B258809X | 1   |   |   |   |   |   | SUBPANEL,FRONT:<br>(ATTACHING PARTS)                                    | 80009    | 386-2330-00      |
|                  | 213-0101-00              | B250000              | B258809X | 11  |   |   |   |   |   | SCR,TPG,THD FOR:4-40 X 0.25 INCH,FLH STL<br>-----*                      | 72228    | OBD              |
| -55              | -----                    |                      |          | 1   |   |   |   |   |   | CKT BOARD ASSY:GRATICULE ILLUM(SEE A10 EPL)                             |          |                  |
| -56              | 378-0728-00              |                      |          | 1   |   |   |   |   |   | . REFLECTOR,LIGHT:SCALE ILLUMINATION                                    | 80009    | 378-0728-00      |
| -57              | 352-0329-00              |                      |          | 1   |   |   |   |   |   | . LAMPHOLDER:SCALE ILLUMINATION                                         | 80009    | 352-0329-00      |
| -58              | 175-0825-00              |                      |          | FT  |   |   |   |   |   | . WIRE,ELECTRICAL:2 WIRE RIBBON                                         | 08261    | OBD              |
| -59              | 131-0707-00              |                      |          | 2   |   |   |   |   |   | . CONTACT,ELEC:0.48"L,22-26 AWG WIRE                                    | 22526    | 75691-005        |
| -60              | 352-0169-02              |                      |          | 1   |   |   |   |   |   | . CONN BODY,PL,EL:2 WIRE RED                                            | 80009    | 352-0169-00      |
| -61              | 386-2340-00              |                      |          | 4   |   |   |   |   |   | SUPPORT,CRT:FRONT                                                       | 80009    | 386-2340-00      |
| -62              | 348-0276-00              |                      |          | FT  |   |   |   |   |   | SHLD GSKT,ELEC:0.026 OD NPRNW/WIRE NET CO                               | 28817    | 01-0404-3719     |
|                  | 426-0926-01              | B250000              | B258809  | 1   |   |   |   |   |   | FRAME,CABINET:FRONT                                                     | 80009    | 426-0926-01      |
| -63              | 426-1108-01              | B258810              |          | 1   |   |   |   |   |   | FRAME,CABINET:FRONT<br>(ATTACHING PARTS)                                | 80009    | 426-1108-01      |
| -64              | 213-0183-00              |                      |          | 4   |   |   |   |   |   | SCR,TPG,THD FOR:6-32 X 0.25 INCH,PNH STL<br>-----*                      | 83385    | OBD              |
| -65              | 129-0388-00              |                      |          | 2   |   |   |   |   |   | POST,ELEC-MECH:1.673 INCH LONG                                          | 80009    | 129-0388-00      |
| -66              | 348-0115-00              |                      |          | 1   |   |   |   |   |   | GROMMET,PLASTIC:U-SHP,0.548 X0.462 INCH                                 | 80009    | 348-0115-00      |
| -67              | 337-1688-00              |                      |          | 1   |   |   |   |   |   | SHLD,ELECTRICAL:HIGH VOLTAGE<br>(ATTACHING PARTS)                       | 80009    | 337-1688-00      |
| -68              | 211-0065-00              |                      |          | 3   |   |   |   |   |   | SCREW,MACHINE:4-40 X 0.188 INCH,PNH STL<br>-----*                       | 77250    | OBD              |
| -69              | -----                    |                      |          | 1   |   |   |   |   |   | CKT BOARD ASSY:FAN MOTOR(SEE A6 EPL)<br>(ATTACHING PARTS)               |          |                  |
| -70              | 213-0088-00              |                      |          | 2   |   |   |   |   |   | SCR,TPG,THD CTG:4-24 X 0.25 INCH,PNH STL<br>-----*                      | 83385    | OBD              |
| -71              | 136-0269-02              |                      |          | 1   |   |   |   |   |   | . CKT BOARD ASSY INCLUDES:<br>. SOCKET,PLUG-IN:14 CONTACT,LOW CLEARANCE | 01295    | C931402          |
| -72              | 131-0608-00              |                      |          | 2   |   |   |   |   |   | . CONTACT,ELEC:0.365 INCH LONG                                          | 22526    | 47357            |
| -73              | 136-0220-00 <sup>1</sup> |                      |          | -   |   |   |   |   |   | . SOCKET,PLUG-IN:3 PIN,SQUARE                                           | 71785    | 133-23-11-034    |
|                  | 136-0252-04              | B010100              | B292379  | 20  |   |   |   |   |   | . SOCKET,PIN TERM:0.188 INCH LONG                                       | 22526    | 75060            |
|                  | 136-0634-00              | B292380              |          | 1   |   |   |   |   |   | SOCKET,PLUG-IN:20 LEAD DIP,CKT BD MTG                                   | 73803    | C932002          |
| -74              | -----                    |                      |          | 1   |   |   |   |   |   | . MOTOR,DC:(SEE B1690 EPL)                                              |          |                  |
| -75              | 426-0781-00              |                      |          | 1   |   |   |   |   |   | . MOUNT,MOTOR:                                                          | 80009    | 426-0781-00      |
| -76              | 337-1762-00              |                      |          | 1   |   |   |   |   |   | SHLD,ELECTRICAL:FAN MOTOR                                               | 80009    | 337-1762-00      |
| -77              | 426-0781-00              |                      |          | 1   |   |   |   |   |   | MOUNT,MOTOR:<br>(ATTACHING PARTS)                                       | 80009    | 426-0781-00      |
| -78              | 213-0088-00              |                      |          | 2   |   |   |   |   |   | SCR,TPG,THD CTG:4-24 X 0.25 INCH,PNH STL<br>-----*                      | 83385    | OBD              |
| -79              | -----                    |                      |          | 1   |   |   |   |   |   | TRANSISTOR:CHAS MTG(SEE Q1418 EPL)<br>(ATTACHING PARTS)                 |          |                  |
| -80              | 211-0012-00              |                      |          | 2   |   |   |   |   |   | SCREW,MACHINE:4-40 X 0.375 INCH,PNH STL                                 | 83385    | OBD              |
| -81              | 358-0214-00              |                      |          | 2   |   |   |   |   |   | INSULATOR,BSHG:0.25 DIA X 0.188 INCH L                                  | 24011    | OBD              |
| -82              | 210-0205-00              |                      |          | 1   |   |   |   |   |   | TERMINAL,LUG:SE #8<br>-----*                                            | 78189    | 2104-08-00-2520N |
| -83              | 214-1610-00              |                      |          | 1   |   |   |   |   |   | HEAT SINK,ELEC:TRANSISTOR                                               | 80009    | 214-1610-00      |

<sup>1</sup>Replace with appropriate part and quantity that is in your instrument.

Replaceable Mechanical Parts—465 Service (SN B250000-up)

| Fig. & Index No. | Tektronix Part No. | Serial/Model No. Eff | Dscont | Qty | 1                                            | 2 | 3 | 4 | 5 | Name & Description         | Mfr Code | Mfr Part Number  |
|------------------|--------------------|----------------------|--------|-----|----------------------------------------------|---|---|---|---|----------------------------|----------|------------------|
| 1-84             | 407-1153-00        |                      |        | 1   | BRKT,XSTR MTG:                               |   |   |   |   | (ATTACHING PARTS)          | 80009    | 407-1153-00      |
| -85              | 210-0586-00        |                      |        | 2   | NUT,PLAIN,EXT W:4-40 X 0.25 INCH,STL         |   |   |   |   | -----*                     | 78189    | OBD              |
| -86              | 348-0253-00        |                      |        | 1   | GROMMET,PLASTIC:1.24 X 0.739 X 0.108" OA     |   |   |   |   |                            | 80009    | 348-0253-00      |
| -87              | 348-0064-00        |                      |        | 2   | GROMMET,PLASTIC:0.625 INCH DIA               |   |   |   |   |                            | 80009    | 348-0064-00      |
|                  | 348-0063-00        |                      |        | 1   | GROMMET,PLASTIC:0.50 INCH DIA                |   |   |   |   |                            | 80009    | 348-0063-00      |
| -88              | 348-0056-00        |                      |        | 4   | GROMMET,PLASTIC:0.375 INCH DIA               |   |   |   |   |                            | 80009    | 348-0056-00      |
| -89              | -----              |                      |        | 1   | DELAY LINE,ELEC:(SEE DL339 EPL)              |   |   |   |   | (ATTACHING PARTS)          |          |                  |
| -90              | 407-1137-00        |                      |        | 1   | BRKT,DELAY LINE:                             |   |   |   |   |                            | 80009    | 407-1137-00      |
| -91              | 210-0457-00        |                      |        | 1   | NUT,PLAIN,EXT W:6-32 X 0.312 INCH,STL        |   |   |   |   | -----*                     | 83385    | OBD              |
|                  | -----              |                      |        | -   | . DELAY LINE INCLUDES:                       |   |   |   |   |                            |          |                  |
|                  | 131-1002-02        |                      |        | 1   | . RETAINER,WIRE,E:                           |   |   |   |   |                            | 80009    | 131-1002-02      |
| -92              | 348-0349-00        |                      |        | FT  | SHLD GSKT,ELEC:0.187 INCH DIA,2.75 FT L      |   |   |   |   |                            | 07700    | 2143951          |
| -93              | 348-0339-00        |                      |        | 4   | FOOT,CABINET:W/CORD WRAP                     |   |   |   |   | (ATTACHING PARTS FOR EACH) | 80009    | 348-0339-00      |
| -94              | 212-0020-00        |                      |        | 1   | SCREW,MACHINE:8-32 X 1.0 INCH,PNH STL        |   |   |   |   | -----*                     | 83385    | OBD              |
| -95              | 426-0970-00        |                      |        | 1   | FR SECT.,CAB.:REAR                           |   |   |   |   | (ATTACHING PARTS)          | 80009    | 426-0970-00      |
| -96              | 211-0516-00        |                      |        | 2   | SCREW,MACHINE:6-32 X 0.875 INCH,PNH STL      |   |   |   |   | -----*                     | 83385    | OBD              |
| -97              | 378-0044-01        |                      |        | 1   | FIL ELEM,AIR CO:                             |   |   |   |   |                            | 80009    | 378-0044-01      |
| -98              | -----              |                      |        | 4   | CONN,RCPT,ELEC:(SEE J165,1318,1338,1450 EPL) |   |   |   |   | (ATTACHING PARTS FOR EACH) |          |                  |
| -99              | 210-0255-00        |                      |        | 1   | TERMINAL,LUG:0.391" ID INT TOOTH             |   |   |   |   | -----*                     | 80009    | 210-0255-00      |
| -100             | 386-2408-00        |                      |        | 1   | PLATE,CONN MTG:BNC CONNECTORS                |   |   |   |   |                            | 80009    | 386-2408-00      |
|                  | 200-1414-05        |                      |        | 1   | COVER,OSCP,REAR:ASSEMBLY                     |   |   |   |   | (ATTACHING PARTS)          | 80009    | 200-1414-05      |
| -101             | 211-0101-00        |                      |        | 2   | SCREW,MACHINE:4-40 X 0.25" 100 DEG,FLH STL   |   |   |   |   | -----*                     | 83385    | OBD              |
|                  | -----              |                      |        | -   | . COVER INCLUDES:                            |   |   |   |   |                            |          |                  |
| -102             | -----              |                      |        | 1   | . COVER,SCOPE:REAR(REPLACEABLE AS ASSY ONLY) |   |   |   |   |                            |          |                  |
| -103             | 378-0807-01        |                      |        | 1   | . METAL,EXPANDED:                            |   |   |   |   |                            | 80009    | 378-0807-01      |
| -104             | 200-1399-01        |                      |        | 1   | . COVER,FAN IMPLR:                           |   |   |   |   |                            | 80009    | 200-1399-01      |
| -105             | 369-0031-01        | B010100 B0261315     |        | 1   | IMP,FAN,AXIAL:                               |   |   |   |   |                            | 80009    | 369-0031-01      |
|                  | 369-0031-00        | B0261316             |        | 1   | IMPLR,FAN,AXIAL:2.60 INCH OD,PLASTIC         |   |   |   |   |                            | 80009    | 369-0031-00      |
| -106             | 105-0507-00        | B010100 B0261315X    |        | 1   | . STOP,SFT END PL:PLASTIC                    |   |   |   |   |                            | 80009    | 105-0507-00      |
|                  | 213-0022-00        | B010100 B0261315X    |        | 1   | . SETSCREW:4-40 X 0.188 INCH,HEX SOC STL     |   |   |   |   |                            | 74445    | OBD              |
| -107             | 200-1445-01        |                      |        | 1   | COV ASSY,LINE V:                             |   |   |   |   |                            | 80009    | 200-1445-01      |
| -108             | 352-0102-00        |                      |        | 1   | . FUSEHOLDER:0.262"ID TUBE FOR CRTG FUSE     |   |   |   |   | (ATTACHING PARTS)          | 80009    | 352-0102-00      |
| -109             | 213-0717-00        |                      |        | 2   | . SCR,TPG,THD CTG:4-40 X 0.312 INCH,PNH STL  |   |   |   |   | -----*                     | 83385    | OBD              |
| -110             | 204-0549-01        |                      |        | 1   | BODY ASSY,LINE:                              |   |   |   |   | (ATTACHING PARTS)          | 80009    | 204-0549-01      |
| -111             | 210-0407-00        |                      |        | 2   | NUT,PLAIN,HEX.:6-32 X 0.25 INCH,BRS          |   |   |   |   |                            | 73743    | 3038-0228-402    |
| -112             | 210-0006-00        |                      |        | 2   | WASHER,LOCK:INTL,0.146 IDX 0.288 OD,STL      |   |   |   |   | -----*                     | 78189    | 1206-00-00-0541C |
|                  | -----              |                      |        | -   | . BODY ASSY INCLUDES:                        |   |   |   |   |                            |          |                  |
|                  | 214-0778-00        |                      |        | 1   | . CONTACT ASSY,EL:SELECTOR BLOCK             |   |   |   |   |                            | 80009    | 214-0778-00      |
|                  | 131-1318-01        |                      |        | 1   | . CONTACT ASSY,EL:SHORTING BAR               |   |   |   |   |                            | 80009    | 131-1318-01      |
| -113             | 161-0033-07        |                      |        | 1   | CABLE ASSY,PWR,:3 WIRE,92 INCH LONG          |   |   |   |   | (ATTACHING PARTS)          | 80009    | 161-0033-07      |
| -114             | 358-0371-00        |                      |        | 1   | BSHG,STRAIN RLF:90 DEG,0.25 INCH DIA HOLE    |   |   |   |   |                            | 80009    | 358-0371-00      |
| -115             | 200-1004-00        |                      |        | 1   | CABLE,NIP.,ELEC:0.265 ID X 0.38"OD W/FLG     |   |   |   |   |                            | 80009    | 200-1004-00      |
| -116             | 358-0372-00        |                      |        | 1   | BSHG,STRAIN RLF:180 DEG,0.156" DIA HOLE      |   |   |   |   | -----*                     | 80009    | 358-0372-00      |



Replaceable Mechanical Parts—465 Service (SN B250000-up)

| Fig. & Index No. | Tektronix Part No. | Serial/Model No. Eff | Dscont | Qty | 1 2 3 4 5 | Name & Description                                                      | Mfr Code | Mfr Part Number  |
|------------------|--------------------|----------------------|--------|-----|-----------|-------------------------------------------------------------------------|----------|------------------|
| 1-117            | 386-2332-00        |                      |        | 1   |           | PANEL, REAR:<br>(ATTACHING PARTS)                                       | 80009    | 386-2332-00      |
| -118             | 211-0105-00        |                      |        | 1   |           | SCREW, MACHINE: 4-40 X 0.188" 100 DEG, FLH STL                          | 83385    | OBD              |
| -119             | 211-0138-00        |                      |        | 1   |           | SCREW, MACHINE: 5-40 X 2.562 INCH, PNH STL                              | 83385    | OBD              |
| -120             | 210-0201-00        |                      |        | 1   |           | TERMINAL, LUG: SE #4                                                    | 78189    | 2104-04-00-2520N |
| -121             | 210-0586-00        |                      |        | 1   |           | NUT, PLAIN, EXT W: 4-40 X 0.25 INCH, STL                                | 78189    | OBD              |
| -122             | 260-0638-00        |                      |        | 1   |           | SW, THERMOSTATIC: 10A, 240V, OPEN 75 DEG C<br>(ATTACHING PARTS)         | 93410    | 110-364          |
| -123             | 213-0044-00        |                      |        | 2   |           | SCR, TPG, THD FOR: 5-32 X 0.188 INCH, PNH STL                           | 83385    | OBD              |
| -124             | -----              |                      |        | 1   |           | XFMR, PWR, STPDN: (SEE T1501 EPL)<br>(ATTACHING PARTS)                  |          |                  |
| -125             | 211-0538-00        |                      |        | 2   |           | SCREW, MACHINE: 6-32 X 0.312" 100 DEG, FLH STL                          | 83385    | OBD              |
| -126             | 210-0457-00        |                      |        | 4   |           | NUT, PLAIN, EXT W: 6-32 X 0.312 INCH, STL                               | 83385    | OBD              |
| -127             | 407-1066-00        |                      |        | 1   |           | . TRANSFORMER INCLUDES:<br>. BRKT, XFMR MTG:                            | 80009    | 407-1066-00      |
| -128             | 212-0522-00        |                      |        | 4   |           | . SCREW, MACHINE: 10-32 X 2.50", HEX HD STL                             | 83385    | OBD              |
| -129             | 210-0812-00        |                      |        | 4   |           | . WASHER, NONMETAL: #10, FIBER                                          | 86445    | OBD              |
| -130             | 166-0457-00        |                      |        | 4   |           | . INSUL SLVG, ELEC: 0.19 ID X 1.875" LONG MYLAR                         | 80009    | 166-0457-00      |
| -131             | 200-1544-01        |                      |        | 1   |           | . COVER, XFMR: 3 L X 2.5 W X 0.65 INCH H                                | 80009    | 200-1544-01      |
| -132             | 210-0056-00        |                      |        | 4   |           | . WASHER, LOCK: SPLIT, 0.195 ID X 0.32" OD, P BRZ                       | 83385    | OBD              |
| -133             | 220-0561-00        |                      |        | 4   |           | . NUT, PLAIN, HEX: 10-32 X 0.25 INCH, BRS                               | 80009    | 220-0561-00      |
| -134             | 337-1763-01        |                      |        | 1   |           | SHIELD, ELEC: TRANSFORMER                                               | 80009    | 337-1763-01      |
| -135             | 210-0201-00        |                      |        | 1   |           | TERMINAL, LUG: SE #4<br>(ATTACHING PARTS)                               | 78189    | 2104-04-00-2520N |
| -136             | 210-0586-00        |                      |        | 1   |           | NUT, PLAIN, EXT W: 4-40 X 0.25 INCH, STL                                | 78189    | OBD              |
| -137             | -----              |                      |        | 3   |           | TRANSISTOR: (SEE Q1566, Q1534, Q1546 EPL)<br>(ATTACHING PARTS FOR EACH) |          |                  |
| -138             | 211-0012-00        |                      |        | 1   |           | . SCREW, MACHINE: 4-40 X 0.375 INCH, PNH STL                            | 83385    | OBD              |
| -139             | 210-0071-00        |                      |        | 1   |           | WASHER, SPR TNSN: 0.146 ID X 0.323" OD, STL                             | 78189    | 4706-05-01-0531  |
| -140             | 342-0163-00        |                      |        | 3   |           | INSULATOR, PLATE: XSTR, 0.675 X 0.625 X 0.001"                          | 80009    | 342-0163-00      |
| -141             | 348-0064-00        |                      |        | 2   |           | GROMMET, PLASTIC: 0.625 INCH DIA                                        | 80009    | 348-0064-00      |
| -142             | 344-0250-00        |                      |        | 1   |           | CLIP, ELECTRICAL: COMPONENT MOUNTING<br>(ATTACHING PARTS)               | 86928    | 4522-5050-2C     |
| -143             | 211-0008-00        |                      |        | 1   |           | SCREW, MACHINE: 4-40 X 0.25 INCH, PNH STL                               | 83385    | OBD              |
| -144             | 210-0586-00        |                      |        | 1   |           | NUT, PLAIN, EXT W: 4-40 X 0.25 INCH, STL                                | 78189    | OBD              |
| -145             | -----              |                      |        | 1   |           | COIL, TUBE DEFLE: (SEE L1440 EPL)                                       |          |                  |
| -146             | 441-1084-03        |                      |        | 1   |           | CHAS, ELEC EQPT: MAIN                                                   | 80009    | 441-1084-03      |
|                  | 214-0291-00        |                      |        | 1   |           | . CONTACT, SPRING: 1.188 X 0.375 X 0.25 INCH<br>(ATTACHING PARTS)       | 80009    | 214-0291-00      |
|                  | 210-0633-01        |                      |        | 1   |           | . EYELET, METALLIC: 0.20 DIA X 0.093 INCH LONG                          | 80009    | 210-0633-01      |
|                  | 136-0515-01        |                      |        | 1   |           | SKT, ELCTRN TUBE: CRT                                                   | 80009    | 136-0515-01      |
| -147             | 136-0202-01        |                      |        | 1   |           | . SOCKET, PLUG-IN: 14 PIN                                               | 80009    | 136-0202-01      |
| -148             | 131-0707-00        |                      |        | 4   |           | . CONTACT, ELEC: 0.48"L, 22-26 AWG WIRE                                 | 22526    | 75691-005        |
| -149             | 352-0162-00        |                      |        | 1   |           | . CONN BODY, PL, EL: 4 WIRE BLACK                                       | 80009    | 352-0162-00      |
| -150             | 179-1873-00        |                      |        | 1   |           | WIRING HARNESS, : TRIGGER                                               | 80009    | 179-1873-00      |
| -151             | 210-0774-00        |                      |        | 8   |           | . EYELET, METALLIC: 0.152 OD X 0.245 INCH L, BRS                        | 80009    | 210-0774-00      |
| -152             | 210-0775-00        |                      |        | 8   |           | . EYELET, METALLIC: 0.126 OD X 0.23 INCH L, BRS                         | 80009    | 210-0775-00      |
| -153             | 352-0169-00        |                      |        | 2   |           | . CONN BODY, PL, EL: 2 WIRE BLACK                                       | 80009    | 352-0169-00      |
|                  | 131-0707-00        |                      |        | 4   |           | . CONTACT, ELEC: 0.48"L, 22-26 AWG WIRE                                 | 22526    | 75691-005        |

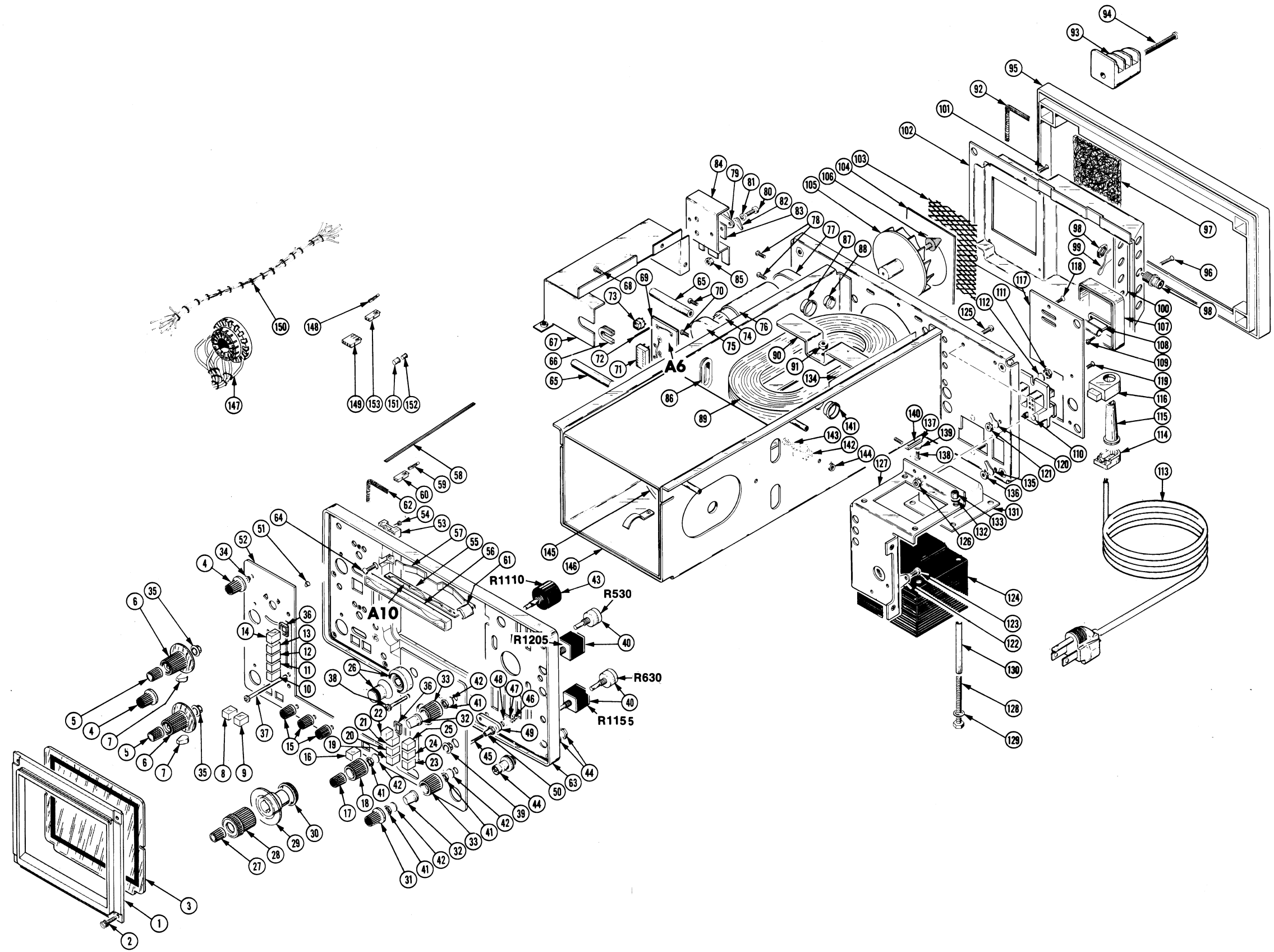

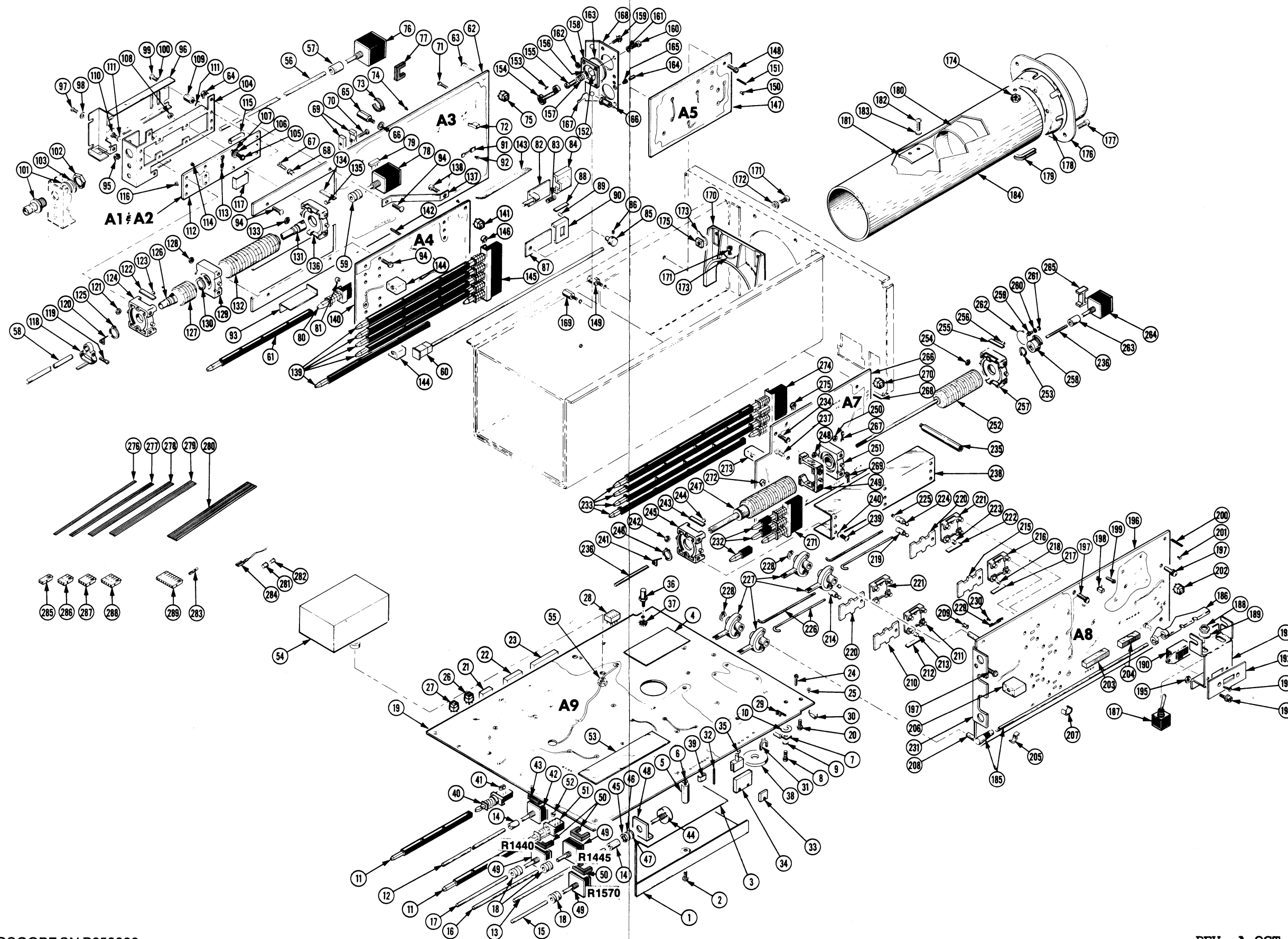

Replaceable Mechanical Parts—465 Service (SN B250000-up)

| Fig. & Index No. | Tektronix Part No. | Serial/Model No. Eff Dscont | Qty | 1 2 3 4 5 | Name & Description                                            | Mfr Code | Mfr Part Number  |
|------------------|--------------------|-----------------------------|-----|-----------|---------------------------------------------------------------|----------|------------------|
| 2-1              | 337-1711-01        |                             | 1   |           | SHLD,ELECTRICAL:HIGH VOLTAGE<br>(ATTACHING PARTS)             | 80009    | 337-1711-01      |
| -2               | 211-0008-00        |                             | 4   |           | SCREW,MACHINE:4-40 X 0.25 INCH,PNH STL                        | 83385    | OBD              |
|                  | 131-1428-00        |                             | 1   |           | CONTACT,ELEC:GROUNDING CLIP                                   | 80009    | 131-1428-00      |
| -3               | 342-0175-00        |                             | 1   |           | INSULATOR,FILM:3.65 X 4.70 INCH                               | 80009    | 342-0175-00      |
| -4               | 342-0159-00        |                             | 1   |           | INSULATOR,FILM:5.10 X 12.4 INCH                               | 80009    | 342-0159-00      |
| -5               | 129-0413-00        |                             | 4   |           | POST,ELEC-MECH:0.538 INCH L                                   | 80009    | 129-0413-00      |
| -6               | 210-0994-00        |                             | 4   |           | WASHER,FLAT:0.125 ID X 0.25" OD,STL                           | 83385    | OBD              |
| -7               | -----              |                             | 2   |           | TRANSISTOR:(SEE Q1556,1570 EPL)<br>(ATTACHING PARTS FOR EACH) |          |                  |
| -8               | 211-0182-00        |                             | 1   |           | SCR,ASSEM WSHR:2-56 X 0.312 INCH,PNH,STL                      | 12360    | OBD              |
| -9               | 210-1156-00        |                             | 1   |           | WASHER,NONMETAL:0.09 ID X 0.121" OD,NYLON                     | 80009    | 210-1156-00      |
| -10              | 342-0166-00        |                             | 1   |           | INSULATOR,PLATE:TRANSISTOR                                    | 80009    | 342-0166-00      |
| -11              | 384-1101-00        |                             | 2   |           | EXTENSION SHAFT:4.14 INCH LONG                                | 80009    | 384-1101-00      |
| -12              | 384-0457-00        |                             | 1   |           | EXTENSION SHAFT:6.7 INCH LONG                                 | 80009    | 384-0457-00      |
| -13              | 384-1179-00        |                             | 1   |           | EXTENSION SHAFT:3.40 INCH LONG                                | 80009    | 384-1179-00      |
| -14              | 376-0029-00        |                             | 2   |           | CPLG,SHAFT,RGD:0.128 ID X 0.312 OD X 0.5"L                    | 80009    | 376-0029-00      |
|                  | 213-0075-00        |                             | 2   |           | . SETSCREW:4-40 X 0.094 INCH,HEX SOC STL                      | 70276    | OBD              |
| -15              | 384-1174-00        |                             | 1   |           | EXTENSION SHAFT:1.80 INCH LONG                                | 80009    | 384-1174-00      |
| -16              | 384-1187-00        |                             | 1   |           | EXTENSION SHAFT:3.40 INCH LONG                                | 80009    | 384-1187-00      |
| -17              | 384-1173-00        |                             | 1   |           | EXTENSION SHAFT:1.90 INCH LONG                                | 80009    | 384-1173-00      |
| -18              | 376-0051-00        |                             | 3   |           | CPLG,SHAFT,FLEX:FOR 0.125 INCH DIA SHAFTS                     | 80009    | 376-0051-00      |
|                  | 213-0022-00        |                             | 4   |           | . SETSCREW:4-40 X 0.188 INCH,HEX SOC STL                      | 74445    | OBD              |
| -19              | -----              |                             | 1   |           | CKT BOARD ASSY:INTERFACE(SEE A9 EPL)<br>(ATTACHING PARTS)     |          |                  |
| -20              | 211-0207-00        |                             | 8   |           | SCR,ASSEM WSHR:4-40 X 0.312 INCH,PNH STL                      | 83385    | OBD              |
|                  | -----              |                             | -   |           | . CKT BOARD ASSY INCLUDES:                                    |          |                  |
| -21              | 136-0499-04        |                             | 1   |           | . CONNECTOR,RCPT,:4 CONTACT                                   | 00779    | 3-380949-4       |
| -22              | 136-0499-10        |                             | 1   |           | . CONNECTOR,RCPT,:10 CONTACT                                  | 00779    | 4-380949-0       |
| -23              | 136-0499-14        |                             | 1   |           | . CONNECTOR,RCPT,:14 CONTACT                                  | 00779    | 4-380949-4       |
| -24              | 214-0579-00        |                             | 8   |           | TERM.,TEST PT:0.40 INCH LONG                                  | 80009    | 214-0579-00      |
| -25              | 136-0252-04        |                             | -   |           | . SOCKET,PIN TERM:0.188 INCH LONG                             | 22526    | 75060            |
| -26              | 136-0219-00        |                             | -   |           | . SOCKET,PLUG-IN:4 PIN                                        | 80009    | 136-0219-00      |
| -27              | 136-0220-00        |                             | -   |           | . SOCKET,PLUG-IN:3 PIN,SQUARE                                 | 71785    | 133-23-11-034    |
| -28              | 136-0514-00        |                             | -   |           | . SOCKET,PLUG IN:MICROCIRCUIT,8 CONTACT                       | 73803    | C9308-02         |
| -29              | 131-1261-00        |                             | 24  |           | . CONTACT,ELEC:F-SHAPED                                       | 00779    | 1-380953-0       |
| -30              | 131-0566-00        |                             | 8   |           | . LINK,TERM.CONNE:0.086 DIA X 2.375 INCH L                    | 55210    | ERD-18T0         |
| -31              | 344-0154-00        |                             | 2   |           | . CLIP,ELECTRICAL:FOR 0.25 INCH DIA FUSE                      | 80009    | 344-0154-00      |
| -32              | 131-0608-00        |                             | 33  |           | . CONTACT,ELEC:0.365 INCH LONG                                | 22526    | 47357            |
| -33              | 124-0118-00        |                             | 1   |           | . TERMINAL BOARD:1 NOTCH                                      | 80009    | 124-0118-00      |
| -34              | 124-0092-00        |                             | 2   |           | . TERMINAL BOARD:3 NOTCH                                      | 80009    | 124-0092-00      |
| -35              | 358-0214-00        |                             | 10  |           | . INSULATOR,BSHG:0.25 DIA X 0.188 INCH L                      | 24011    | OBD              |
| -36              | 131-0382-00        |                             | 1   |           | . TERMINAL,STUD:<br>(ATTACHING PARTS)                         | 71279    | 4822-1-0516      |
| -37              | 210-0586-00        |                             | 1   |           | . NUT,PLAIN,EXT W:4-40 X 0.25 INCH,STL                        | 78189    | OBD              |
| -38              | 210-0966-00        |                             | 1   |           | . WASHER,NONMETAL:0.312 ID X 0.875" OD,RBR                    | 80009    | 210-0966-00      |
| -39              | 214-0973-00        |                             | 1   |           | . HEAT SINK,ELEC:0.28 X 0.18 OVAL X 0.187"H                   | 80009    | 214-0973-00      |
| -40              | -----              |                             | 1   |           | . SW,PUSH BUTTON:BEAMFINDER(SEE S400 EPL)                     |          |                  |
| -41              | 361-0385-00        |                             | 2   |           | . SPACER,PB SW:0.164 INCH LONG                                | 80009    | 361-0385-00      |
| -42              | -----              |                             | 1   |           | . RES.,VAR,NONWIR:INTENSITY(SEE R1460 EPL)                    |          |                  |
| -43              | 361-0607-00        |                             | 1   |           | . SPACER,SWITCH:PLASTIC                                       | 80009    | 361-0607-00      |
| -44              | -----              |                             | 1   |           | . RES.,VAR,NONWIR:FOCUS(SEE R1430 EPL)<br>(ATTACHING PARTS)   |          |                  |
| -45              | 210-0583-00        |                             | 1   |           | . NUT,PLAIN,HEX.:0.25-32 X 0.312 INCH,BRS                     | 73743    | 2X20224-402      |
| -46              | 210-0046-00        |                             | 1   |           | . WASHER,LOCK:INTL:0.26 ID X 0.40" OD,STL                     | 78189    | 1214-05-00-0541C |
| -47              | 210-0940-00        |                             | 1   |           | . WASHER,FLAT:0.25 ID X 0.375 INCH OD,STL                     | 79807    | OBD              |
| -48              | 386-2433-00        |                             | 1   |           | . SUPPORT,VAR RES:CIRCUIT BOARD MOUNTING                      | 80009    | 386-2433-00      |
| -49              | -----              |                             | 3   |           | . RES.,VAR,NONWIR:(SEE R1440,1445,1570 EPL)                   |          |                  |

<sup>1</sup>Replace with appropriate part and quantity that is in your instrument.

Replaceable Mechanical Parts—465 Service (SN B250000-up)

| Fig. & Index No. | Tektronix Part No. | Serial/Model No. Eff Dscnt | Qty | 1 2 3 4 5 | Name & Description                                                            | Mfr Code | Mfr Part Number |
|------------------|--------------------|----------------------------|-----|-----------|-------------------------------------------------------------------------------|----------|-----------------|
| 2-50             | 361-0607-00        |                            | 3   |           | . SPACER, SWITCH: PLASTIC                                                     | 80009    | 361-0607-00     |
| -51              | -----              |                            | 1   |           | . SW, PUSH BUTTON: X10 MAG (SEE S1239 EPL)                                    |          |                 |
| -52              | 361-0385-00        |                            | 2   |           | . SPACER, PB SW: 0.164 INCH LONG                                              | 80009    | 361-0385-00     |
| -53              | 337-1759-00        |                            | 1   |           | . SHLD, ELECTRICAL: SWEEP                                                     | 80009    | 337-1759-00     |
| -54              | -----              |                            | 1   |           | . SEMICOND DEVICE: VOLTAGE MULTR (SEE U1432 EPL)<br>(ATTACHING PARTS)         |          |                 |
| -55              | 220-0661-00        | B250000 B252904            | 2   |           | . NUT, SLFLKG, HEX: 8-32 X 0.344 X 0.215", NYLON                              | 23050    | OBD             |
|                  | 220-0736-00        | B252905                    | 2   |           | . NUT, PL, EXT WSHR: 8-32 X 0.343 X 0.437", NYL                               | 23050    | OBD             |
|                  |                    |                            |     |           | -----*                                                                        |          |                 |
| -56              | 384-1149-00        |                            | 2   |           | EXTENSION SHAFT: 7.0 INCH LONG                                                | 80009    | 384-1149-00     |
| -57              | 376-0029-00        |                            | 2   |           | CPLG, SHAFT, RGD: 0.128 ID X 0.312 OD X 0.5"L                                 | 80009    | 376-0029-00     |
|                  | 213-0075-00        |                            | 2   |           | . SETSCREW: 4-40 X 0.094 INCH, HEX SOC STL                                    | 70276    | OBD             |
| -58              | 384-1180-00        |                            | 2   |           | EXTENSION SHAFT: 6.40 INCH LONG                                               | 80009    | 384-1180-00     |
| -59              | 376-0051-00        |                            | 2   |           | CPLG, SHAFT, FLEX: FOR 0.125 INCH DIA SHAFTS                                  | 80009    | 376-0051-00     |
|                  | 213-0022-00        |                            | 4   |           | . SETSCREW: 4-40 X 0.188 INCH, HEX SOC STL                                    | 74445    | OBD             |
| -60              | 384-1162-00        |                            | 1   |           | EXTENSION SHAFT: 11.42 INCH LONG, W/KNOB                                      | 80009    | 384-1162-00     |
| -61              | 384-1129-00        |                            | 1   |           | EXTENSION SHAFT: 5.607 INCH LONG                                              | 80009    | 384-1129-00     |
|                  | 672-0620-00        |                            | 1   |           | CKT BOARD ASSY: VERTICAL                                                      | 80009    | 672-0620-00     |
| -62              | -----              |                            | 1   |           | CKT BOARD ASSY: VERTICAL PREAMP (SEE A3 EPL)<br>(ATTACHING PARTS)             |          |                 |
| -63              | 211-0207-00        |                            | 7   |           | SCR, ASSEM WSHR: 4-40 X 0.312 INCH, PNH STL                                   | 83385    | OBD             |
| -64              | 210-0586-00        |                            | 5   |           | NUT, PLAIN, EXT W: 4-40 X 0.25 INCH, STL                                      | 78189    | OBD             |
| -65              | 129-0413-00        |                            | 1   |           | POST, ELEC-MECH: 0.538 INCH L                                                 | 80009    | 129-0413-00     |
| -66              | 210-0994-00        |                            | 1   |           | WASHER, FLAT: 0.125 ID X 0.25" OD, STL                                        | 83385    | OBD             |
|                  |                    |                            |     |           | -----*                                                                        |          |                 |
|                  | 131-1428-00        |                            | 1   |           | CONTACT, ELEC: GROUNDING CLIP                                                 | 80009    | 131-1428-00     |
|                  | -----              |                            | -   |           | . CKT BOARD ASSY INCLUDES:                                                    |          |                 |
| -67              | 131-0344-00        |                            | 2   |           | . TERMINAL, STUD: BIFURCATED<br>(ATTACHING PARTS FOR EACH)                    | 88245    | 421837-9        |
| -68              | 358-0176-00        |                            | 1   |           | . INSULATOR, BSHG:                                                            | 88245    | 421472          |
|                  |                    |                            |     |           | -----*                                                                        |          |                 |
| -69              | 200-0945-00        |                            | 6   |           | . COVER, HALF XSTR: FOR DUAL TO-18 CASE                                       | 80009    | 200-0945-00     |
|                  | 200-0945-01        |                            | 6   |           | . COVER, HALF XSTR: FOR DUAL TO-18 CS, 2-56 THD<br>(ATTACHING PARTS FOR EACH) | 80009    | 200-0945-01     |
| -70              | 211-0062-00        |                            | 1   |           | . SCREW, MACHINE: 2-56 X 0.312 INCH, RDH STL                                  | 83385    | OBD             |
|                  |                    |                            |     |           | -----*                                                                        |          |                 |
| -71              | 214-0579-00        |                            | 12  |           | . TERM., TEST PT: 0.40 INCH LONG                                              | 80009    | 214-0579-00     |
| -72              | 131-1003-00        |                            | 9   |           | . CONNECTOR BODY: CKT CD MT, 3 PRONG                                          | 80009    | 131-1003-00     |
| -73              | 352-0086-00        |                            | 1   |           | . HOLDER, TOROID: 0.50 INCH DIA                                               | 80009    | 352-0086-00     |
| -74              | 136-0252-01        |                            | 2   |           | . CONTACT, ELEC: 0.178 INCH LONG                                              | 00779    | 1-332095-2      |
|                  | 136-0252-04        |                            | 129 |           | . SOCKET, PIN TERM: 0.188 INCH LONG                                           | 22526    | 75060           |
| -75              | 136-0220-00        |                            | 8   |           | . SOCKET, PLUG-IN: 3 PIN, SQUARE                                              | 71785    | 133-23-11-034   |
| -76              | -----              |                            | 2   |           | . RES., VAR, NONWIR: (SEE R311, 381 EPL)                                      |          |                 |
| -77              | 361-0607-00        |                            | 2   |           | . SPACER, SWITCH: PLASTIC                                                     | 80009    | 361-0607-00     |
| -78              | -----              |                            | 2   |           | . RES., VAR, NONWIR: (SEE R112, 212 EPL)                                      |          |                 |
| -79              | 361-0515-00        |                            | 2   |           | . SPACER, SWITCH: PLASTIC                                                     | 80009    | 361-0515-00     |
| -80              | -----              |                            | 1   |           | . SW, PUSH BUTTON: INVERT (SEE S225 EPL)                                      |          |                 |
| -81              | 361-0411-00        |                            | 2   |           | . SPACER, PUSH SW: 0.13 W X 0.375 INCH L, PLSTC                               | 71590    | J64285-00       |
|                  | 105-0421-00        |                            | 1   |           | . ACTUATOR, SWITCH:                                                           | 80009    | 105-0421-00     |
| -82              | 105-0420-00        |                            | 1   |           | . . ACTUATOR, SWITCH:                                                         | 80009    | 105-0420-00     |
| -83              | 214-1779-00        |                            | 1   |           | . . SPRING, HLCPS: 0.156 OD X 0.844 INCH LONG                                 | 80009    | 214-1779-00     |
| -84              | 351-0359-00        |                            | 1   |           | . . GUIDE, SW SLIDE:                                                          | 80009    | 351-0359-00     |
|                  | 105-0423-00        |                            | 1   |           | . ACTUATOR, SWITCH:                                                           | 80009    | 105-0423-00     |
| -85              | 376-0146-00        |                            | 1   |           | . . CPLG, SHAFT, RGD: FOR 0.125 INCH DIA SHAFT                                | 80009    | 376-0146-00     |
| -86              | 213-0048-00        |                            | 1   |           | . . SETSCREW: 4-40 X 0.125 INCH, HEX SOC STL                                  | 74445    | OBD             |
| -87              | 105-0422-00        |                            | 1   |           | . ACTUATOR, SWITCH:                                                           | 80009    | 105-0422-00     |
| -88              | 214-1126-01        |                            | 2   |           | . . SPRING, FLAT: GREEN COLORED                                               | 80009    | 214-1126-01     |
| -89              | 214-1127-00        |                            | 2   |           | . . ROLLER, DETENT: 0.125 DIA X 0.125 INCH L                                  | 80009    | 214-1127-00     |
| -90              | 351-0355-00        |                            | 1   |           | . . GUIDE, SLIDE SW:                                                          | 80009    | 351-0355-00     |
| -91              | 131-1030-00        |                            | 4   |           | . CONTACT ASSY, EL: CAM SWITCH, BOTTOM                                        | 80009    | 131-1030-00     |
|                  | 131-1031-00        |                            | 5   |           | . CONTACT ASSY, EL: CAM SWITCH, TOP<br>(ATTACHING PARTS)                      | 80009    | 131-1031-00     |
| -92              | 210-0779-00        |                            | 6   |           | . RIVET, TUBULAR: 0.051 OD X 0.115 INCH LONG                                  | 42838    | RA-29952715     |
|                  |                    |                            |     |           | -----*                                                                        |          |                 |

Replaceable Mechanical Parts—465 Service (SN B250000-up)

| Fig. & Index No. | Tektronix Part No.                        | Serial/Model No. Eff Dscont | Qty | 1 2 3 4 5 | Name & Description                                                 | Mfr Code | Mfr Part Number  |
|------------------|-------------------------------------------|-----------------------------|-----|-----------|--------------------------------------------------------------------|----------|------------------|
| 2-93             | 337-1804-00<br>672-0416-00                |                             | 2   |           | SHLD,ELECTRICAL:ATTENUATOR                                         | 80009    | 337-1804-00      |
|                  |                                           |                             | 2   |           | CKT BOARD ASSY:CH1 & CH2 ATTENUATORS<br>(ATTACHING PARTS FOR EACH) | 80009    | 672-0416-00      |
| -94              | 211-0207-00                               |                             | 6   |           | SCR,ASSEM WSHR:4-40 X 0.312 INCH,PNH STL                           | 83385    | OBD              |
| -95              | 210-0586-00                               |                             | 2   |           | NUT,PLAIN,EXT W:4-40 X 0.25 INCH,STL                               | 78189    | OBD              |
|                  | -----                                     |                             | -   |           | . EACH ASSY INCLUDES:                                              |          |                  |
| -96              | 200-1438-00                               |                             | 1   |           | . COVER,CHASSIS:ATTENUATOR<br>(ATTACHING PARTS)                    | 80009    | 200-1438-00      |
| -97              | 213-0176-00                               |                             | 3   |           | . SCR,TPG,THD FOR:2-32 X 0.156 INCH,PNH,STL                        | 83385    | OBD              |
| -98              | 210-0938-00                               |                             | 3   |           | . WASHER,FLAT:0.109 ID X 0.25 INCH OD,STL                          | 75497    | AN960-3          |
| -99              | 211-0008-00                               |                             | 4   |           | . SCREW,MACHINE:4-40 X 0.25 INCH,PNH STL                           | 83385    | OBD              |
| -100             | 210-0851-00                               |                             | 4   |           | . WASHER,FLAT:0.119 ID X 0.375 INCH OD,STL                         | 12327    | OBD              |
|                  |                                           |                             | -   |           | . . . . .                                                          |          |                  |
| -101             | 131-0679-02                               |                             | 1   |           | . CONNECTOR,RCPT,:BNC W/HARDWARE<br>(ATTACHING PARTS)              | 24931    | 28JR270-1        |
| -102             | 220-0695-00                               |                             | 1   |           | . NUT,PLAIN,DODEC:0.500-28 X 0.90 INCH,BRS                         | 73743    | OBD              |
| -103             | 210-1039-00                               |                             | 1   |           | . WASHER,LOCK:INT,0.521 ID X 0.625 INCH OD<br>(ATTACHING PARTS)    | 24931    | OBD              |
|                  |                                           |                             | -   |           | . . . . .                                                          |          |                  |
| -104             | 441-1095-00                               |                             | 1   |           | . CHAS,ELEC EQPT:ATTENUATOR<br>(ATTACHING PARTS)                   | 80009    | 441-1095-00      |
| -105             | 211-0001-00                               |                             | 2   |           | . SCREW,MACHINE:2-56 X 0.25 INCH,PNH STL                           | 83385    | OBD              |
| -106             | 210-1008-00                               |                             | 2   |           | . WASHER,FLAT:0.09 ID X 0.188" OD,BRS                              | 12360    | OBD              |
| -107             | 210-0053-00                               |                             | 2   |           | . WASHER,LOCK:INTL,0.092 ID X 0.175"OD,STL                         | 83385    | OBD              |
| -108             | 210-0405-00                               |                             | 2   |           | . NUT,PLAIN,HEX.:2-56 X 0.188 INCH,BRS                             | 73743    | 2X12157-402      |
| -109             | 129-0299-00                               |                             | 4   |           | . POST,ELEC-MECH:HEX,0.333 INCH LONG                               | 80009    | 129-0299-00      |
| -110             | 211-0097-00                               |                             | 2   |           | . SCREW,MACHINE:4-40 X 0.312 INCH,PNH STL                          | 83385    | OBD              |
| -111             | 210-0004-00                               |                             | 6   |           | . WASHER,LOCK:INTL,0.12 ID X 0.26"OD,STL<br>(ATTACHING PARTS)      | 78189    | 1204-00-00-0541C |
|                  |                                           |                             | -   |           | . . . . .                                                          |          |                  |
| -112             | -----                                     |                             | 1   |           | . CKT BOARD ASSY:ATTENUATOR(SEE A1 OR A2 EPL)                      | 80009    | 131-1030-00      |
| -113             | 131-1030-00<br>131-1031-00                |                             | 6   |           | . . CONTACT ASSY,EL:CAM SWITCH,BOTTOM                              | 80009    | 131-1030-00      |
|                  |                                           |                             | 8   |           | . . CONTACT ASSY,EL:CAM SWITCH,TOP<br>(ATTACHING PARTS)            | 80009    | 131-1031-00      |
| -114             | 210-0779-00                               |                             | 8   |           | . . RIVET,TUBULAR:0.051 OD X 0.115 INCH LONG<br>(ATTACHING PARTS)  | 42838    | RA-29952715      |
|                  |                                           |                             | -   |           | . . . . .                                                          |          |                  |
| -115             | 131-1354-00                               |                             | 2   |           | . . LINK,TERM.CONN:                                                | 80009    | 131-1354-00      |
| -116             | 136-0252-01<br>136-0333-00                |                             | 4   |           | . . CONTACT,ELEC:0.178 INCH LONG                                   | 00779    | 1-332095-2       |
|                  |                                           |                             | 1   |           | . . SOCKET,PIN TERM:0.138 INCH LONG                                | 00779    | 1-331677-4       |
| -117             | 337-1406-00<br>263-1012-00                |                             | 1   |           | . . SHLD,ELECTRICAL:CAM CONTACTS                                   | 80009    | 337-1406-00      |
|                  |                                           |                             | 1   |           | . ACTUATOR ASSY:ATTENUATOR                                         | 80009    | 263-1012-00      |
| -118             | 105-0243-00                               |                             | 1   |           | . . ACTUATOR,SWITCH:<br>(ATTACHING PARTS)                          | 80009    | 105-0243-00      |
| -119             | 213-0214-00                               |                             | 1   |           | . . SCREW,CAP SCH:2-56 X 0.375"HEX HD STL<br>(ATTACHING PARTS)     | 70278    | OBD              |
|                  |                                           |                             | -   |           | . . . . .                                                          |          |                  |
| -120             | 131-0963-00                               |                             | 2   |           | . . CONTACT,ELEC:GROUNDING                                         | 80009    | 131-0963-00      |
| -121             | 210-0406-00                               |                             | 2   |           | . . NUT,PLAIN,HEX.:4-40 X 0.188 INCH,BRS                           | 73743    | 2X12161-402      |
| -122             | 214-1139-03                               |                             | 2   |           | . . SPRING,FLAT:RED COLORED                                        | 80009    | 214-1139-03      |
| -123             | 214-1752-00                               |                             | 2   |           | . . ROLLER,DETENT:0.125 OD X 0.16 INCH L                           | 80009    | 214-1752-00      |
| -124             | 401-0180-00                               |                             | 1   |           | . . BEARING,CAM SW:FRONT<br>(ATTACHING PARTS)                      | 80009    | 401-0180-00      |
| -125             | 354-0390-00                               |                             | 1   |           | . . RING,RETAINING:0.338 ID X 0.025" THK,STL<br>(ATTACHING PARTS)  | 79136    | 5100-37MD        |
|                  |                                           |                             | -   |           | . . . . .                                                          |          |                  |
| -126             | 384-0878-02                               |                             | 1   |           | . . SHAFT,CAM SW:W/DRIVER                                          | 80009    | 384-0878-02      |
| -127             | 105-0282-01<br>210-1189-00<br>214-2043-00 |                             | 1   |           | . . DRUM,CAM SWITCH:DC,GND,AC                                      | 80009    | 105-0282-01      |
|                  |                                           |                             | 1   |           | . . WASHER,FLAT:0.195 ID X 0.367 INCH OD,BRS                       | 51316    | OBD              |
|                  |                                           |                             | 1   |           | . . SPRING,HLCPS:CONICAL,0.20 INCH LONG                            | 80009    | 214-2043-00      |
| -128             | 210-0406-00                               |                             | 4   |           | . . NUT,PLAIN,HEX.:4-40 X 0.188 INCH,BRS                           | 73743    | 2X12161-402      |
| -129             | 401-0178-00                               |                             | 1   |           | . . BEARING,CAM SW:CENTER/REAR<br>(ATTACHING PARTS)                | 80009    | 401-0178-00      |
| -130             | 354-0443-00                               |                             | 1   |           | . . RING,RETAINING:0.328 FREE IDX 0.448 OD<br>(ATTACHING PARTS)    | 97464    | 200-37           |
|                  |                                           |                             | -   |           | . . . . .                                                          |          |                  |
| -131             | 384-0880-00                               |                             | 1   |           | . . SHAFT,CAM SW:REAR,W/DRIVER                                     | 80009    | 384-0880-00      |
| -132             | 105-0342-01                               |                             | 1   |           | . . ACTUATOR CAM:VOLTS/DIV                                         | 80009    | 105-0342-01      |

Replaceable Mechanical Parts—465 Service (SN B250000-up)

| Fig. & Index No. | Tektronix Part No. | Serial/Model No. Eff | Dscont | Qty | 1                                            | 2 | 3 | 4 | 5 | Name & Description                   | Mfr Code | Mfr Part Number  |  |
|------------------|--------------------|----------------------|--------|-----|----------------------------------------------|---|---|---|---|--------------------------------------|----------|------------------|--|
| 2-133            | 210-0406-00        |                      |        | 4   | .                                            | . | . | . | . | NUT,PLAIN,HEX.:4-40 X 0.188 INCH,BRS | 73743    | 2X12161-402      |  |
| -134             | 214-1139-02        |                      |        | 1   | .                                            | . | . | . | . | SPRING,FLAT:GREEN COLORED            | 80009    | 214-1139-02      |  |
|                  | 214-1139-03        |                      |        | 1   | .                                            | . | . | . | . | SPRING,FLAT:RED COLORED              | 80009    | 214-1139-03      |  |
| -135             | 214-1752-00        |                      |        | 2   | .                                            | . | . | . | . | ROLLER,DETENT:0.125 OD X 0.16 INCH   | 80009    | 214-1752-00      |  |
| -136             | 401-0180-00        |                      |        | 1   | .                                            | . | . | . | . | BEARING,CAM SW:FRONT                 | 80009    | 401-0180-00      |  |
| -137             | 346-0102-00        |                      |        | 1   | STRAP,GROUNDING:                             |   |   |   |   |                                      | 80009    | 346-0102-00      |  |
|                  |                    |                      |        |     | (ATTACHING PARTS)                            |   |   |   |   |                                      |          |                  |  |
| -138             | 211-0207-00        |                      |        | 1   | SCR,ASSEM WSHR:4-40 X 0.312 INCH,PNH STL     |   |   |   |   |                                      | 83385    | OBD              |  |
|                  |                    |                      |        |     | - - - * - - - -                              |   |   |   |   |                                      |          |                  |  |
| -139             | 384-1129-00        |                      |        | 5   | EXTENSION SHAFT:5.607 INCH LONG              |   |   |   |   |                                      | 80009    | 384-1129-00      |  |
| -140             | -----              |                      |        | 1   | CKT BOARD ASSY:VERTICAL MODE(SEE A4 EPL)     |   |   |   |   |                                      |          |                  |  |
| -141             | 136-0220-00        |                      |        | 4   | . SOCKET,PLUG-IN:3 PIN,SQUARE                |   |   |   |   |                                      | 71785    | 133-23-11-034    |  |
| -142             | 131-0608-00        |                      |        | 8   | . CONTACT,ELEC:0.365 INCH LONG               |   |   |   |   |                                      | 22526    | 47357            |  |
| -143             | 175-0828-00        |                      |        | FT  | . WIRE,ELECTRICAL:5 WIRE RIBBON              |   |   |   |   |                                      | 08261    | OBD              |  |
| -144             | 352-0331-00        |                      |        | 2   | . LAMPHOLDER:                                |   |   |   |   |                                      | 80009    | 352-0331-00      |  |
| -145             | -----              |                      |        | 1   | . SW,PUSH BUTTON:VERT MODE(SEE S350 EPL)     |   |   |   |   |                                      |          |                  |  |
| -146             | 361-0411-00        |                      |        | 4   | . SPACER,PUSH SW:0.13 W X 0.375 INCH L,PLSTC |   |   |   |   |                                      | 71590    | J64285-00        |  |
| -147             | -----              |                      |        | 1   | CKT BOARD ASSY:VERT OUTPUT(SEE A5 EPL)       |   |   |   |   |                                      |          |                  |  |
|                  |                    |                      |        |     | (ATTACHING PARTS)                            |   |   |   |   |                                      |          |                  |  |
| -148             | 211-0207-00        |                      |        | 2   | SCR,ASSEM WSHR:4-40 X 0.312 INCH,PNH STL     |   |   |   |   |                                      | 83385    | OBD              |  |
| -149             | 129-0450-00        |                      |        | 1   | POST,ELEC-MECH:0.656 LG X 0.250"HEX,STUDED   |   |   |   |   |                                      | 80009    | 129-0450-00      |  |
|                  |                    |                      |        |     | - - - * - - - -                              |   |   |   |   |                                      |          |                  |  |
|                  |                    |                      |        | -   | . CKT BOARD ASSY INCLUDES:                   |   |   |   |   |                                      |          |                  |  |
| -150             | 136-0252-04        |                      |        | 32  | . SOCKET,PIN TERM:0.188 INCH LONG            |   |   |   |   |                                      | 22526    | 75060            |  |
|                  | 136-0252-01        |                      |        | 2   | . CONTACT,ELEC:0.178 INCH LONG               |   |   |   |   |                                      | 00779    | 1-332095-2       |  |
| -151             | 131-0608-00        |                      |        | 5   | . CONTACT,ELEC:0.365 INCH LONG               |   |   |   |   |                                      | 22526    | 47357            |  |
| -152             | -----              |                      |        | 2   | TRANSISTOR:(SEE Q482,492 EPL)                |   |   |   |   |                                      |          |                  |  |
| -153             | 210-0627-00        |                      |        | 2   | RIVET,SOLID:0.042 DIA X 0.25 INCH,RDH        |   |   |   |   |                                      | 80009    | 210-0627-00      |  |
| -154             | 343-0097-00        |                      |        | 2   | RTNR,TRANSISTOR:HEAT SINK                    |   |   |   |   |                                      | 80009    | 343-0097-00      |  |
|                  |                    |                      |        |     | (ATTACHING PARTS FOR EACH)                   |   |   |   |   |                                      |          |                  |  |
| -155             | 210-0599-00        |                      |        | 2   | NUT,SLEEVE:4-40 X 0.391 INCH LONG            |   |   |   |   |                                      | 80009    | 210-0599-00      |  |
| -156             | 210-0004-00        |                      |        | 2   | WASHER,LOCK:INTL,0.12 ID X 0.26"OD,STL       |   |   |   |   |                                      | 78189    | 1204-00-00-0541C |  |
| -157             | 214-0368-00        |                      |        | 1   | SPRING,HLCPS:0.24 DIA X 0.438 INCH LONG      |   |   |   |   |                                      | 80009    | 214-0368-00      |  |
|                  |                    |                      |        |     | - - - * - - - -                              |   |   |   |   |                                      |          |                  |  |
| -158             | 352-0062-00        |                      |        | 2   | HOLDER,HEAT SK:1.187 X 1.187 INCHES,PLSTC    |   |   |   |   |                                      | 80009    | 352-0062-00      |  |
|                  |                    |                      |        |     | (ATTACHING PARTS FOR EACH)                   |   |   |   |   |                                      |          |                  |  |
| -159             | 211-0033-00        |                      |        | 2   | SCR,ASSEM WSHR:4-40 X 0.312 INCH,PNH STL     |   |   |   |   |                                      | 83385    | OBD              |  |
| -160             | 211-0012-00        |                      |        | 2   | . SCREW,MACHINE:4-40 X 0.375 INCH,PNH STL    |   |   |   |   |                                      | 83385    | OBD              |  |
| -161             | 210-0004-00        |                      |        | 2   | WASHER,LOCK:INTL,0.12 ID X 0.26"OD,STL       |   |   |   |   |                                      | 78189    | 1204-00-00-0541C |  |
| -162             | 210-0406-00        |                      |        | 4   | NUT,PLAIN,HEX.:4-40 X 0.188 INCH,BRS         |   |   |   |   |                                      | 73743    | 2X12161-402      |  |
|                  |                    |                      |        |     | - - - * - - - -                              |   |   |   |   |                                      |          |                  |  |
| -163             | 214-1138-00        |                      |        | 2   | HEAT SINK,ELEC:TRANSISTOR,1 INCH OD,AL       |   |   |   |   |                                      | 80009    | 214-1138-00      |  |
| -164             | 131-0235-00        |                      |        | 2   | TERMINAL,STUD:0.213 DIA X 0.455 INCH L       |   |   |   |   |                                      | 88245    | 420977-9         |  |
|                  |                    |                      |        |     | (ATTACHING PARTS FOR EACH)                   |   |   |   |   |                                      |          |                  |  |
| -165             | 358-0136-00        |                      |        | 1   | INSULATOR,BSHG:                              |   |   |   |   |                                      | 88245    | 420971           |  |
|                  |                    |                      |        |     | - - - * - - - -                              |   |   |   |   |                                      |          |                  |  |
| -166             | 131-0761-00        |                      |        | 1   | TERMINAL STUD:SCREW MTG,FLAT TAB             |   |   |   |   |                                      | 71279    | 572-4897-01-0516 |  |
|                  |                    |                      |        |     | (ATTACHING PARTS)                            |   |   |   |   |                                      |          |                  |  |
| -167             | 210-0202-00        |                      |        | 1   | TERMINAL,LUG:SE #6                           |   |   |   |   |                                      | 78189    | 2104-06-00-2520N |  |
|                  |                    |                      |        |     | - - - * - - - -                              |   |   |   |   |                                      |          |                  |  |
| -168             | 407-1389-00        |                      |        | 1   | BRKT,HEAT SINK:                              |   |   |   |   |                                      | 80009    | 407-1389-00      |  |
|                  |                    |                      |        |     | (ATTACHING PARTS)                            |   |   |   |   |                                      |          |                  |  |
| -169             | 129-0450-00        |                      |        | 2   | POST,ELEC-MECH:0.656 LG X 0.250"HEX,STUDED   |   |   |   |   |                                      | 80009    | 129-0450-00      |  |
|                  |                    |                      |        |     | - - - * - - - -                              |   |   |   |   |                                      |          |                  |  |
| -170             | 407-1128-00        |                      |        | 1   | BRKT,CRT SHIELD:REAR                         |   |   |   |   |                                      | 80009    | 407-1128-00      |  |
|                  |                    |                      |        |     | (ATTACHING PARTS)                            |   |   |   |   |                                      |          |                  |  |
| -171             | 211-0507-00        |                      |        | 3   | SCREW,MACHINE:6-32 X 0.312 INCH,PNH STL      |   |   |   |   |                                      | 83385    | OBD              |  |
| -172             | 210-0803-00        |                      |        | 2   | WASHER,FLAT:0.15 ID X 0.375 INCH OD,STL      |   |   |   |   |                                      | 12327    | OBD              |  |
| -173             | 210-0202-00        |                      |        | 2   | TERMINAL,LUG:SE #6                           |   |   |   |   |                                      | 78189    | 2104-06-00-2520N |  |
| -174             | 210-0457-00        |                      |        | 1   | NUT,PLAIN,EXT W:6-32 X 0.312 INCH,STL        |   |   |   |   |                                      | 83385    | OBD              |  |
| -175             | 220-0419-00        |                      |        | 2   | NUT,PLAIN,SQ:6-32 X 0.312 INCH,STL           |   |   |   |   |                                      | 83385    | OBD              |  |
|                  |                    |                      |        |     | - - - * - - - -                              |   |   |   |   |                                      |          |                  |  |



Replaceable Mechanical Parts—465 Service (SN B250000-up)

| Fig. & Index No. | Tektronix Part No.       | Serial/Model No. Eff | Discont | Qty | 1 2 3 4 5 | Name & Description                                                 | Mfr Code | Mfr Part Number  |
|------------------|--------------------------|----------------------|---------|-----|-----------|--------------------------------------------------------------------|----------|------------------|
| 2-176            | 200-1459-00              |                      |         | 1   |           | COVER,CRT:REAR<br>(ATTACHING PARTS)                                | 80009    | 200-1459-00      |
| -177             | 211-0008-00              |                      |         | 2   |           | SCREW,MACHINE:4-40 X 0.25 INCH,PNH STL<br>- - - * - - -            | 83385    | OBD              |
| -178             | 386-2246-00              |                      |         | 1   |           | SUPPORT,CRT:REAR                                                   | 80009    | 386-2246-00      |
| -179             | 348-0145-00              |                      |         | 1   |           | GROMMET,PLASTIC:U-SHP,1.0 X 0.42 INCH                              | 80009    | 348-0145-00      |
| -180             | -----                    |                      |         | 1   |           | COIL,TUBE DEFLE:Y-AXIS(SEE L1446 EPL)<br>(ATTACHING PARTS)         |          |                  |
| -181             | 343-0217-00              |                      |         | 1   |           | CLAMP,COIL:Y-AXIS                                                  | 80009    | 343-0217-00      |
| -182             | 211-0147-00              |                      |         | 2   |           | SCREW,MACHINE:4-40 X 0.25 INCH,PNH STL                             | 83385    | OBD              |
| -183             | 210-0994-00              |                      |         | 2   |           | WASHER,FLAT:0.125 ID X 0.25" OD,STL<br>- - - * - - -               | 83385    | OBD              |
| -184             | 337-1644-00              |                      |         | 1   |           | SHLD,ELECTRICAL:CRT NECK                                           | 80009    | 337-1644-00      |
| -185             | 384-1159-00              |                      |         | 1   |           | EXTENSION SHAFT:10.384 INCH LONG,W/KNOB                            | 80009    | 384-1159-00      |
| -186             | 214-1756-00              |                      |         | 1   |           | ACTUATOR,SWITCH:POWER                                              | 80009    | 214-1756-00      |
| -187             | -----                    |                      |         | 1   |           | SWITCH,TOGGLE:POWER ON(SEE S1501 EPL)<br>(ATTACHING PARTS)         |          |                  |
| -188             | 210-0562-00              |                      |         | 1   |           | NUT,PLAIN,HEX.:0.25-40 X 0.312 INCH,BBS                            | 73743    | 2X20224-402      |
| -189             | 210-0046-00              |                      |         | 1   |           | WASHER,LOCK:INTL,0.26 ID X 0.40" OD,STL<br>- - - * - - -           | 78189    | 1214-05-00-0541C |
| -190             | -----                    |                      |         | 1   |           | SWITCH,SLIDE:LINE SELECT(SEE S1503 EPL)<br>(ATTACHING PARTS)       |          |                  |
| -191             | 211-0101-00              |                      |         | 2   |           | SCREW,MACHINE:4-40 X 0.25" 100 DEG,FLH STL<br>- - - * - - -        | 83385    | OBD              |
| -192             | 200-1526-00              |                      |         | 1   |           | COV,INV SW HOLE:                                                   | 80009    | 200-1526-00      |
| -193             | 407-1133-00              |                      |         | 1   |           | BRACKET,SW MTG:POWER SWITCH<br>(ATTACHING PARTS)                   | 80009    | 407-1133-00      |
| -194             | 211-0116-00              |                      |         | 1   |           | SCR,ASSEM WSHR:4-40 X 0.312 INCH,PNH BRS                           | 83385    | OBD              |
| -195             | 210-0551-00              |                      |         | 1   |           | NUT,PLAIN,HEX.:4-40 X 0.25 INCH,STL                                | 83385    | OBD              |
|                  | 210-0406-00              |                      |         | 1   |           | NUT,PLAIN,HEX.:4-40 X 0.188 INCH,BRS                               | 73743    | 2X12161-402      |
|                  | 210-0994-00              |                      |         | 2   |           | WASHER,FLAT:0.125 ID X 0.25" OD,STL                                | 83385    | OBD              |
|                  | 386-2660-00              |                      |         | 1   |           | SUPPORT,CKT CD:PLASTIC<br>- - - * - - -                            | 80009    | 386-2660-00      |
| -196             | -----                    |                      |         | 1   |           | CKT BOARD ASSY:TRIG GEN,SWP LOGIC(SEE A8 EPL)<br>(ATTACHING PARTS) |          |                  |
| -197             | 211-0207-00              |                      |         | 5   |           | SCR,ASSEM WSHR:4-40 X 0.312 INCH,PNH STL<br>- - - * - - -          | 83385    | OBD              |
|                  | -----                    |                      |         | -   |           | CKT BOARD ASSY INCLUDES:                                           |          |                  |
| -198             | 131-1003-00              |                      |         | 8   |           | CONNECTOR BODY,:CKT CD MT,3 PRONG                                  | 80009    | 131-1003-00      |
| -199             | 214-0579-00              |                      |         | 3   |           | TERM.,TEST PT:0.40 INCH LONG                                       | 80009    | 214-0579-00      |
| -200             | 131-0608-00              |                      |         | 10  |           | CONTACT,ELEC:0.365 INCH LONG                                       | 22526    | 47357            |
| -201             | 136-0252-04 <sup>1</sup> |                      |         | -   |           | SOCKET,PIN TERM:0.188 INCH LONG                                    | 22526    | 75060            |
| -202             | 136-0220-00 <sup>1</sup> |                      |         | -   |           | SOCKET,PLUG-IN:3 PIN,SQUARE                                        | 71785    | 133-23-11-034    |
|                  | 136-0260-02 <sup>1</sup> |                      |         | -   |           | SOCKET,PLUG-IN:16 CONTACT,LOW CLEARANCE                            | 01295    | C931602          |
| -203             | 136-0499-14              |                      |         | 1   |           | CONNECTOR,RCPT,:14 CONTACT                                         | 00779    | 4-380949-4       |
| -204             | 136-0499-10              |                      |         | 1   |           | CONNECTOR,RCPT,:10 CONTACT                                         | 00779    | 4-380949-0       |
| -205             | 200-1167-00              |                      |         | 2   |           | COVER,XSTR:TEMP STAB FOR 2 TO-18 CS STYLE                          | 80009    | 200-1167-00      |
| -206             | 352-0331-00              |                      |         | 3   |           | LAMPHOLDER:                                                        | 80009    | 352-0331-00      |
| -207             | 214-0973-00              |                      |         | 1   |           | HEAT SINK,ELEC:0.28 X 0.18 OVAL X 0.187"H                          | 80009    | 214-0973-00      |
| -208             | 386-2376-00              |                      |         | 1   |           | PLATE,LEVER MTG:SLIDE SWITCH<br>(ATTACHING PARTS)                  | 80009    | 386-2376-00      |
| -209             | 210-0657-01              |                      |         | 2   |           | EYELET,METALLIC:0.089 OD X 0.218 INCH LONG<br>- - - * - - -        | 80009    | 210-0657-01      |
|                  | 105-0401-00              |                      |         | 1   |           | ACTUATOR,SWITCH:B(DLY'D) SOURCE                                    | 80009    | 105-0401-00      |
| -210             | 105-0417-00              |                      |         | 1   |           | ACTUATOR,SWITCH:                                                   | 80009    | 105-0417-00      |
| -211             | 351-0355-00              |                      |         | 1   |           | GUIDE,SLIDE SW:                                                    | 80009    | 351-0355-00      |
| -212             | 214-1126-01              |                      |         | 2   |           | SPRING,FLAT:GREEN COLORED                                          | 80009    | 214-1126-01      |
| -213             | 214-1127-00              |                      |         | 2   |           | ROLLER,DETENT:0.125 DIA X 0.125 INCH L                             | 80009    | 214-1127-00      |
| -214             | 376-0142-00              |                      |         | 1   |           | ADPT,SHAFT,CPLG:SLIDE TO SHAFT                                     | 80009    | 376-0142-00      |
|                  | 213-0048-00              |                      |         | 1   |           | SETScrew:4-40 X 0.125 INCH,HEX SOC STL                             | 74445    | OBD              |
|                  | 105-0400-00              |                      |         | 1   |           | ACTUATOR,SWITCH:A SOURCE                                           | 80009    | 105-0400-00      |
| -215             | 105-0418-00              |                      |         | 1   |           | ACTUATOR,SWITCH:                                                   | 80009    | 105-0418-00      |
| -216             | 351-0355-00              |                      |         | 1   |           | GUIDE,SLIDE SW:                                                    | 80009    | 351-0355-00      |

<sup>1</sup>Replace with appropriate part and quantity that is in your instrument.

Replaceable Mechanical Parts—465 Service (SN B250000-up)

| Fig. & Index No. | Tektronix Part No. | Serial/Model No. Eff | Dscont | Qty | 1 | 2 | 3 | 4 | 5 | Name & Description                        | Mfr Code | Mfr Part Number  |
|------------------|--------------------|----------------------|--------|-----|---|---|---|---|---|-------------------------------------------|----------|------------------|
| 2-217            | 214-1126-01        |                      |        | 2   | . | . | . | . | . | SPRING,FLAT:GREEN COLORED                 | 80009    | 214-1126-01      |
| -218             | 214-1127-00        |                      |        | 2   | . | . | . | . | . | ROLLER,DETENT:0.125 DIA X 0.125 INCH L    | 80009    | 214-1127-00      |
| -219             | 376-0142-00        |                      |        | 1   | . | . | . | . | . | ADPT,SHAFT,CPLG:SLIDE TO SHAFT            | 80009    | 376-0142-00      |
|                  | 213-0048-00        |                      |        | 1   | . | . | . | . | . | SETScrew:4-40 X 0.125 INCH,HEX SOC STL    | 74445    | OBD              |
|                  | 105-0399-00        |                      |        | 2   | . | . | . | . | . | ACTUATOR,SWITCH:A & B COUPLING            | 80009    | 105-0399-00      |
| -220             | 105-0419-00        |                      |        | 1   | . | . | . | . | . | ACTUATOR,SWITCH:                          | 80009    | 105-0419-00      |
| -221             | 351-0355-00        |                      |        | 1   | . | . | . | . | . | GUIDE,SLIDE SW:                           | 80009    | 351-0355-00      |
| -222             | 214-1126-00        |                      |        | 2   | . | . | . | . | . | SPRING,FLAT:GOLD COLORED                  | 80009    | 214-1126-00      |
| -223             | 214-1127-00        |                      |        | 2   | . | . | . | . | . | ROLLER,DETENT:0.125 DIA X 0.125 INCH L    | 80009    | 214-1127-00      |
| -224             | 376-0142-00        |                      |        | 1   | . | . | . | . | . | ADPT,SHAFT,CPLG:SLIDE TO SHAFT            | 80009    | 376-0142-00      |
| -225             | 213-0048-00        |                      |        | 1   | . | . | . | . | . | SETScrew:4-40 X 0.125 INCH,HEX SOC STL    | 74445    | OBD              |
| -226             | 384-1160-00        |                      |        | 4   | . | . | . | . | . | EXTENSION SHAFT:3.05 INCH LONG            | 80009    | 384-1160-00      |
| -227             | 214-1770-00        |                      |        | 4   | . | . | . | . | . | LEVER,SLIDE SW:                           | 80009    | 214-1770-00      |
|                  |                    |                      |        |     |   |   |   |   |   | (ATTACHING PARTS)                         |          |                  |
| -228             | 354-0165-00        |                      |        | 2   | . | . | . | . | . | RING,RETAINING:0.114 FREE IDX 0.025 INCH  | 97464    | 1000-15          |
|                  |                    |                      |        |     |   |   |   |   |   | - - - * - - -                             |          |                  |
| -229             | 131-1031-00        |                      |        | 23  | . | . | . | . | . | CONTACT ASSY,EL:CAM SWITCH,TOP            | 80009    | 131-1031-00      |
|                  |                    |                      |        |     |   |   |   |   |   | (ATTACHING PARTS FOR EACH)                |          |                  |
| -230             | 210-0779-00        |                      |        | 1   | . | . | . | . | . | RIVET,TUBULAR:0.051 OD X 0.115 INCH LONG  | 42838    | RA-29952715      |
|                  |                    |                      |        |     |   |   |   |   |   | - - - * - - -                             |          |                  |
| -231             | 407-1157-00        |                      |        | 1   | . | . | . | . | . | BRACKET,SWITCH:TRIGGER BOARD              | 80009    | 407-1157-00      |
| -232             | 384-1136-00        |                      |        | 3   | . | . | . | . | . | EXTENSION SHAFT:0.95 INCH LONG            | 80009    | 384-1136-00      |
| -233             | 384-1059-00        |                      |        | 4   | . | . | . | . | . | EXTENSION SHAFT:6.58 INCH LONG            | 80009    | 384-1059-00      |
|                  | 672-0451-00        |                      |        | 1   | . | . | . | . | . | CKT BOARD ASSY:TIMING                     | 80009    | 672-0451-00      |
|                  |                    |                      |        |     |   |   |   |   |   | (ATTACHING PARTS)                         |          |                  |
| -234             | 211-0207-00        |                      |        | 1   | . | . | . | . | . | SCR,ASSEM WSHR:4-40 X 0.312 INCH,PNH STL  | 83385    | OBD              |
| -235             | 129-0386-00        |                      |        | 1   | . | . | . | . | . | POST,ELEC-MECH:HEX,1.593 INCH LONG        | 80009    | 129-0386-00      |
|                  |                    |                      |        |     |   |   |   |   |   | - - - * - - -                             |          |                  |
|                  |                    |                      |        |     |   |   |   |   |   | . TIMING ASSY INCLUDES:                   |          |                  |
| -236             | 384-1277-00        |                      |        | 1   | . | . | . | . | . | EXTENSION SHAFT:8.23 INCH LONG            | 80009    | 384-1277-00      |
|                  | 263-1086-00        |                      |        | 1   | . | . | . | . | . | DRUM ASSY,CAM S:TIME/CM                   | 80009    | 263-1086-00      |
|                  |                    |                      |        |     |   |   |   |   |   | (ATTACHING PARTS)                         |          |                  |
| -237             | 211-0207-00        |                      |        | 8   | . | . | . | . | . | SCR,ASSEM WSHR:4-40 X 0.312 INCH,PNH STL  | 83385    | OBD              |
|                  |                    |                      |        |     |   |   |   |   |   | - - - * - - -                             |          |                  |
|                  |                    |                      |        |     |   |   |   |   |   | . . . ACTUATOR ASSY INCLUDES:             |          |                  |
| -238             | 200-1707-00        |                      |        | 1   | . | . | . | . | . | COVER,CAM SW:                             | 80009    | 200-1707-00      |
|                  |                    |                      |        |     |   |   |   |   |   | (ATTACHING PARTS)                         |          |                  |
| -239             | 211-0008-00        |                      |        | 8   | . | . | . | . | . | SCREW,MACHINE:4-40 X 0.25 INCH,PNH STL    | 83385    | OBD              |
| -240             | 210-0004-00        |                      |        | 8   | . | . | . | . | . | WASHER,LOCK:INTL,0.12 ID X 0.26"OD,STL    | 78189    | 1204-00-00-0541C |
|                  |                    |                      |        |     |   |   |   |   |   | - - - * - - -                             |          |                  |
| -241             | 131-0963-00        |                      |        | 2   | . | . | . | . | . | CONTACT,ELEC:GROUNDING                    | 80009    | 131-0963-00      |
| -242             | 210-0406-00        |                      |        | 2   | . | . | . | . | . | NUT,PLAIN,HEX.:4-40 X 0.188 INCH,BRS      | 73743    | 2X12161-402      |
| -243             | 214-1139-02        |                      |        | 1   | . | . | . | . | . | SPRING,FLAT:GREEN COLORED                 | 80009    | 214-1139-02      |
|                  | 214-1139-03        |                      |        | 1   | . | . | . | . | . | SPRING,FLAT:RED COLORED                   | 80009    | 214-1139-03      |
| -244             | 214-1127-00        |                      |        | 2   | . | . | . | . | . | ROLLER,DETENT:0.125 DIA X 0.125 INCH L    | 80009    | 214-1127-00      |
| -245             | 401-0081-02        |                      |        | 1   | . | . | . | . | . | BEARING,CAM SW:FRONT                      | 80009    | 401-0081-02      |
|                  |                    |                      |        |     |   |   |   |   |   | (ATTACHING PARTS)                         |          |                  |
| -246             | 354-0391-00        |                      |        | 1   | . | . | . | . | . | RING,RETAINING:0.395"FREE ID X 0.025" STL | 97464    | 3100-43-CD       |
|                  |                    |                      |        |     |   |   |   |   |   | - - - * - - -                             |          |                  |
| -247             | 105-0615-00        |                      |        | 1   | . | . | . | . | . | DRUM,CAM SWITCH:TIME/CM,FRONT             | 80009    | 105-0615-00      |
| -248             | 210-0406-00        |                      |        | 4   | . | . | . | . | . | NUT,PLAIN,HEX.:4-40 X 0.188 INCH,BRS      | 73743    | 2X12161-402      |
| -249             | 407-1199-00        |                      |        | 1   | . | . | . | . | . | BRACKET,COVER:CAM SWITCH                  | 80009    | 407-1199-00      |
| -250             | 210-0406-00        |                      |        | 4   | . | . | . | . | . | NUT,PLAIN,HEX.:4-40 X 0.188 INCH,BRS      | 73743    | 2X12161-402      |
| -251             | 401-0115-00        |                      |        | 1   | . | . | . | . | . | BEARING,CAM SW:CENTER                     | 80009    | 401-0115-00      |
| -252             | 105-0614-00        |                      |        | 1   | . | . | . | . | . | DRUM,CAM SWITCH:TIME/CM REAR              | 80009    | 105-0614-00      |
|                  |                    |                      |        |     |   |   |   |   |   | (ATTACHING PARTS)                         |          |                  |
| -253             | 354-0391-00        |                      |        | 1   | . | . | . | . | . | RING,RETAINING:0.395"FREE ID X 0.025" STL | 97464    | 3100-43-CD       |
|                  |                    |                      |        |     |   |   |   |   |   | - - - * - - -                             |          |                  |
| -254             | 210-0406-00        |                      |        | 4   | . | . | . | . | . | NUT,PLAIN,HEX.:4-40 X 0.188 INCH,BRS      | 73743    | 2X12161-402      |
| -255             | 214-1139-02        |                      |        | 1   | . | . | . | . | . | SPRING,FLAT:GREEN COLORED                 | 80009    | 214-1139-02      |
|                  | 214-1139-03        |                      |        | 1   | . | . | . | . | . | SPRING,FLAT:RED COLORED                   | 80009    | 214-1139-03      |
| -256             | 214-1127-00        |                      |        | 2   | . | . | . | . | . | ROLLER,DETENT:0.125 DIA X 0.125 INCH L    | 80009    | 214-1127-00      |

| Fig. & Index No. | Tektronix Part No. | Serial/Model No. Eff | Dscont | Qty | 1 | 2 | 3 | 4 | 5 | Name & Description                          | Mfr Code | Mfr Part Number |
|------------------|--------------------|----------------------|--------|-----|---|---|---|---|---|---------------------------------------------|----------|-----------------|
| 2-257            | 401-0081-04        |                      |        | 1   | . | . | . | . | . | BEARING,CAM SW:W/INSERT,REAR                | 80009    | 401-0081-04     |
|                  | 351-0366-00        |                      |        | 1   | . | . | . | . | . | SLIDE,STOP:ACTUATOR                         | 80009    | 351-0366-00     |
|                  | 105-0410-00        |                      |        | 1   | . | . | . | . | . | STOP,ROT.SHAFT:CAM SWITCH                   | 80009    | 105-0410-00     |
| -258             | 352-0350-00        |                      |        | 1   | . | . | . | . | . | HOLDER,STOP PIN:                            | 80009    | 352-0350-00     |
|                  | 213-0048-00        |                      |        | 1   | . | . | . | . | . | SETSCREW:4-40 X 0.125 INCH,HEX SOC STL      | 74445    | OBD             |
| -259             | 105-0409-00        |                      |        | 1   | . | . | . | . | . | STOP,SHAFT:ACTUATOR                         | 80009    | 105-0409-00     |
| -260             | 361-0535-00        |                      |        | 1   | . | . | . | . | . | SPACER,RING:0.130 ID X 0.18 INCH OD         | 80009    | 361-0535-00     |
| -261             | 354-0291-00        |                      |        | 1   | . | . | . | . | . | RING,RETAINING:TRUARC                       | 97464    | 2000-12-CD      |
| -262             | 214-1812-00        |                      |        | 1   | . | . | . | . | . | SPG,HLCCL,TRSN:CAM SWITCH                   | 80009    | 214-1812-00     |
| -263             | 376-0039-00        |                      |        | 1   | . | . | . | . | . | ADPT,SHAFT,CPLG:0.128 AND 0.082"DIA SHAFT   | 80009    | 376-0039-00     |
|                  | 213-0022-00        |                      |        | 2   | . | . | . | . | . | SETSCREW:4-40 X 0.188 INCH,HEX SOC STL      | 74445    | OBD             |
| -264             | -----              |                      |        | 1   | . | . | . | . | . | RES.,VAR,NONWIR:(SEE R1140/S1140 EPL)       |          |                 |
| -265             | 361-0515-00        |                      |        | 1   | . | . | . | . | . | SPACER,SWITCH:PLASTIC                       | 80009    | 361-0515-00     |
| -266             | -----              |                      |        | 1   | . | . | . | . | . | CKT BOARD ASSY:TIMING(SEE A7 EPL)           |          |                 |
| -267             | 131-0604-00        |                      |        | 37  | . | . | . | . | . | CONTACT,ELEC:0.025 SQ X 0.365 INCH LONG     | 80009    | 131-0604-00     |
| -268             | 131-0608-00        |                      |        | 19  | . | . | . | . | . | CONTACT,ELEC:0.365 INCH LONG                | 22526    | 47357           |
| -269             | 131-1261-00        |                      |        | 28  | . | . | . | . | . | CONTACT,ELEC:F-SHAPED                       | 00779    | 1-380953-0      |
| -270             | 136-0220-00        |                      |        | 2   | . | . | . | . | . | SOCKET,PLUG-IN:3 PIN,SQUARE                 | 71785    | 133-23-11-034   |
| -271             | -----              |                      |        | 1   | . | . | . | . | . | SW,PUSH BUTTON:TRIG MODE(SEE S1100 EPL)     |          |                 |
| -272             | 361-0542-00        |                      |        | 4   | . | . | . | . | . | SPACER,SWITCH:PLASTIC                       | 71590    | J-64281         |
| -273             | 352-0331-00        |                      |        | 2   | . | . | . | . | . | LAMPHOLDER:                                 | 80009    | 352-0331-00     |
| -274             | -----              |                      |        | 1   | . | . | . | . | . | SW,PUSH BUTTON:HORIZ DISPLAY(SEE S1120 EPL) |          |                 |
| -275             | 361-0385-00        |                      |        | 4   | . | . | . | . | . | SPACER,PB SW:0.164 INCH LONG                | 80009    | 361-0385-00     |
| -276             | 175-0825-00        |                      |        | FT  | . | . | . | . | . | WIRE,ELECTRICAL:2 WIRE RIBBON,29.5 INCHES   | 08261    | OBD             |
| -277             | 175-0826-00        |                      |        | FT  | . | . | . | . | . | WIRE,ELECTRICAL:3 WIRE RIBBON,3.5 INCHES    | 80009    | 175-0826-00     |
| -278             | 175-0827-00        |                      |        | FT  | . | . | . | . | . | WIRE,ELECTRICAL:4 WIRE RIBBON,4 INCHES      | 08261    | TEK-175-0827-00 |
| -279             | 175-0828-00        |                      |        | FT  | . | . | . | . | . | WIRE,ELECTRICAL:5 WIRE RIBBON,13 INCHES     | 08261    | OBD             |
| -280             | 175-0831-00        |                      |        | FT  | . | . | . | . | . | WIRE,ELECTRICAL:8 WIRE RIBBON,10.25 INCHES  | 08261    | OBD             |
| -281             | 210-0774-00        |                      |        | 3   | . | . | . | . | . | EYELET,METALLIC:0.152 OD X 0.245 INCH L,BRS | 80009    | 210-0774-00     |
| -282             | 210-0775-00        |                      |        | 3   | . | . | . | . | . | EYELET,METALLIC:0.126 OD X 0.23 INCH L,BRS  | 80009    | 210-0775-00     |
| -283             | 131-0707-00        |                      |        | 46  | . | . | . | . | . | CONTACT,ELEC:0.48"L,22-26 AWG WIRE          | 22526    | 75691-005       |
|                  | 131-0371-00        |                      |        | 2   | . | . | . | . | . | CONTACT,ELEC:FOR NO.26 AWG WIRE             | 98278    | 122-0182-019    |
| -284             | 131-0472-01        |                      |        | 4   | . | . | . | . | . | CONTACT,ELEC:FEMALE                         | 80009    | 131-0472-01     |
| -285             | 352-0169-00        |                      |        | 4   | . | . | . | . | . | CONN BODY,PL,EL:2 WIRE BLACK                | 80009    | 352-0169-00     |
| -286             | 352-0161-00        |                      |        | 1   | . | . | . | . | . | CONN BODY,PL,EL:3 WIRE BLACK                | 80009    | 352-0161-00     |
| -287             | 352-0162-00        |                      |        | 1   | . | . | . | . | . | CONN BODY,PL,EL:4 WIRE BLACK                | 80009    | 352-0162-00     |
| -288             | 352-0163-00        |                      |        | 3   | . | . | . | . | . | CONN BODY,PL,EL:5 WIRE BLACK                | 80009    | 352-0163-00     |
| -289             | 352-0166-00        |                      |        | 2   | . | . | . | . | . | CONN BODY,PL,EL:8 WIRE BLACK                | 80009    | 352-0166-00     |



CABINET

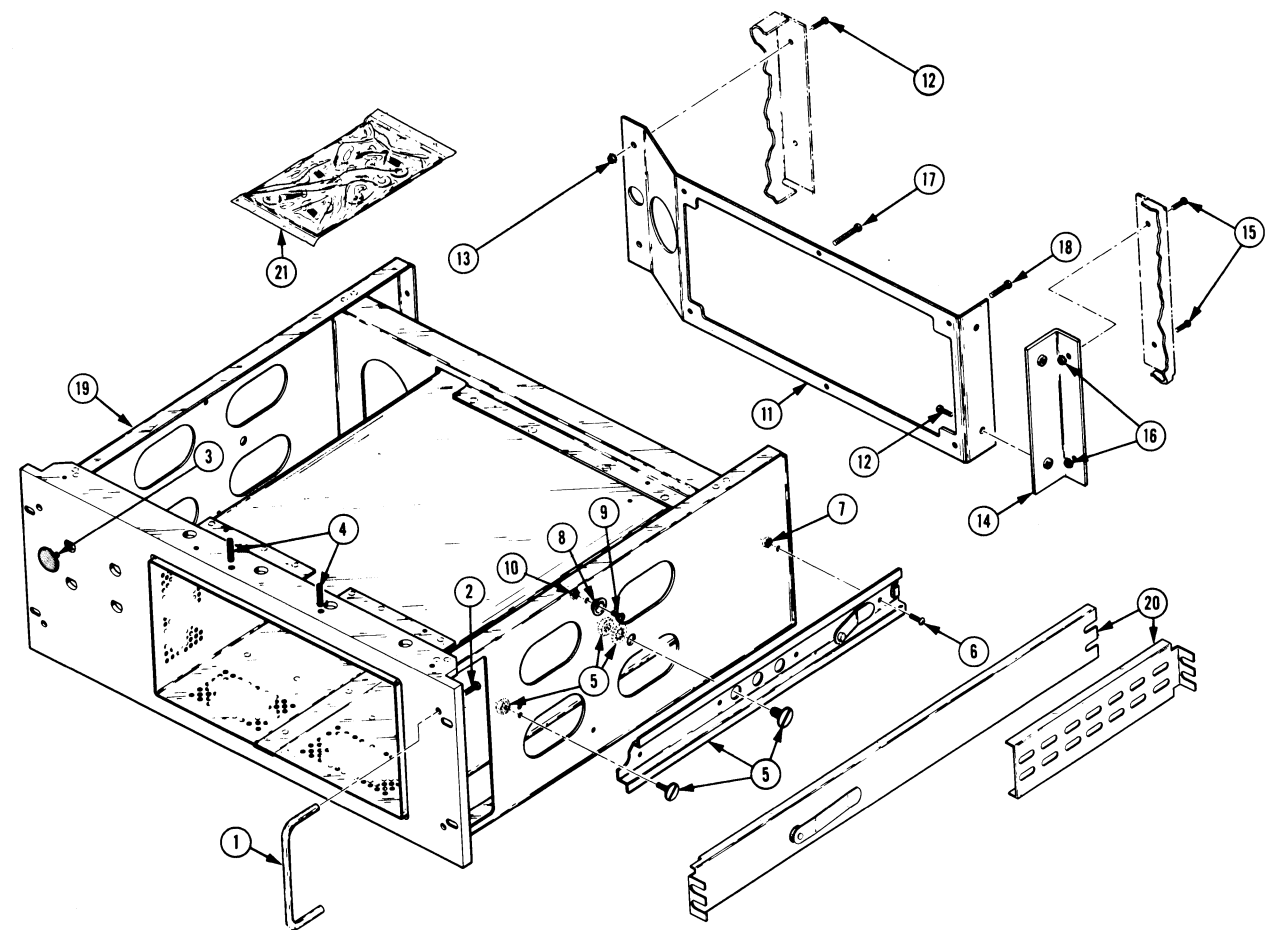
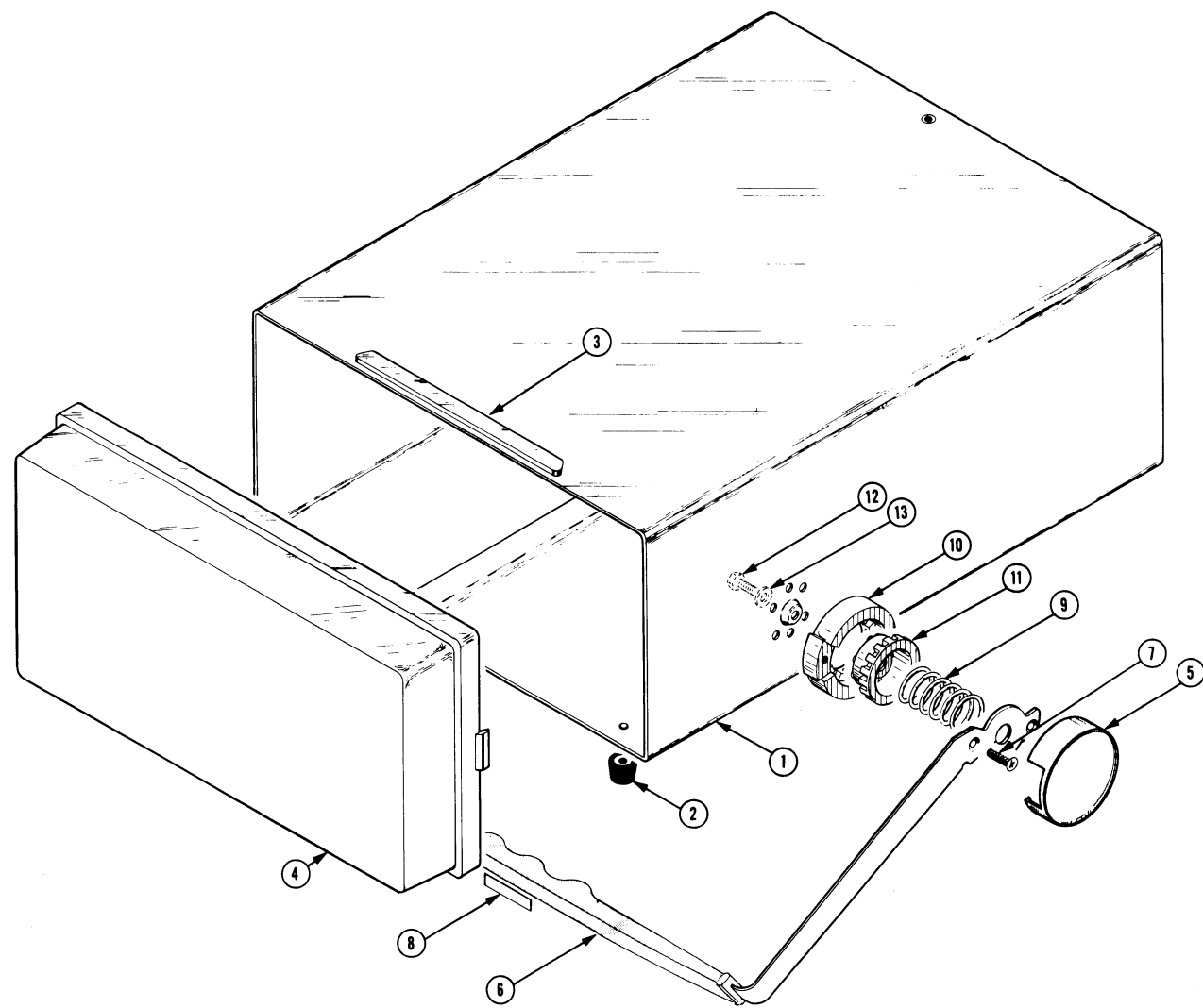

| Fig. & Index No. | Tektronix Part No. | Serial/Model No. Eff | Dscont  | Qty | 1 2 3 4 5 | Name & Description                         | Mfr Code | Mfr Part Number |
|------------------|--------------------|----------------------|---------|-----|-----------|--------------------------------------------|----------|-----------------|
| 3-1              | 437-0141-00        |                      |         | 1   |           | CAB,ELEC EQUIP:STANDARD                    | 80009    | 437-0141-00     |
|                  | 437-0174-00        |                      |         | 1   |           | CAB,ELEC EQUIP:WITH DM43/DM40              | 80009    | 437-0174-00     |
| -2               | 348-0080-01        |                      |         | 4   |           | . FOOT,CABINET:BOTTOM                      | 80009    | 348-0080-01     |
| -3               | 352-0263-00        |                      |         | 1   |           | . HLDR,POUCH ASSY:5.5 INCH LONG,PLASTIC    | 80009    | 352-0263-0      |
| -4               | 200-1412-00        |                      |         | 1   |           | COVER,SCOPE:FRONT                          | 80009    | 200-1412-00     |
|                  | 200-1723-00        |                      |         | 1   |           | COVER,SCOPE:FRONT,W/DM43/DM40              | 80009    | 200-1723-00     |
| -5               | 200-0602-00        |                      |         | 2   |           | COVER,HINGE:                               | 80009    | 200-0602-00     |
| -6               | 367-0140-03        | B250000              | B256499 | 1   |           | HANDLE,CARRYING:                           | 80009    | 367-0140-03     |
|                  | 367-0195-00        | B256500              |         | 1   |           | HANDLE,CARRYING:                           | 80009    | 367-0195-00     |
|                  |                    |                      |         |     |           | (ATTACHING PARTS)                          |          |                 |
| -7               | 211-0512-00        | B250000              | B246599 | 4   |           | SCREW,MACHINE:6-32 X 0.50" 100 DEG,FLH STL | 83385    | OBD             |
|                  | 213-0227-00        | B256500              |         | 4   |           | SCR,TPG,THD FOR:6-32 X 0.50 DEG,FLH ST     | 83385    | OBD             |
|                  |                    |                      |         |     |           | -----*                                     |          |                 |
| -8               | 334-1998-00        |                      |         | 1   |           | PLATE,IDENT:                               | 80009    | 334-1998-00     |
| -9               | 214-0516-00        |                      |         | 2   |           | SPRING,HLCPS:0.959 DIA X 1.250 INCH LONG   | 80009    | 214-0516-00     |
| -10              | 214-0513-04        | B250000              | B256499 | 2   |           | HUB,HDL INDEX:                             | 80009    | 214-0513-01     |
|                  | 214-1987-00        | B256500              |         | 2   |           | INDEX,HDL RING:                            | 80009    | 214-1987-00     |
| -11              | 214-0515-02        |                      |         | 2   |           | GEAR,HDL INDEX:                            | 80009    | 214-0515-02     |
|                  |                    |                      |         |     |           | (ATTACHING PARTS FOR EACH)                 |          |                 |
| -12              | 213-0139-00        |                      |         | 1   |           | SCR,CAP,HEX HD:10-24 X 0.375 INCH LONG     | 14438    | OBD             |
| -13              | 210-1182-00        |                      |         | 1   |           | WSHR,SPR TNSN:0.218 ID X 0.69 INCH OD      | 80009    | 210-1182-00     |
|                  |                    |                      |         |     |           | -----*                                     |          |                 |

| Fig. & Index No. | Tektronix Part No. | Serial/Model No. Eff | Dscont | Qty | 1 2 3 4 5 | Name & Description                                        | Mfr Code | Mfr Part Number  |
|------------------|--------------------|----------------------|--------|-----|-----------|-----------------------------------------------------------|----------|------------------|
| 4-               | 016-0556-00        |                      |        | 1   |           | ADPTR,RACK MTG:KIT                                        | 80009    | 016-0556-00      |
| -1               | 367-0022-00        |                      |        | 2   |           | . HANDLE,BOW:1.5 X 4.5 INCH<br>(ATTACHING PARTS FOR EACH) | 06540    | 10353-B-1032-25A |
| -2               | 213-0090-00        |                      |        | 2   |           | . SCREW,MACHINE:10-32 X 0.50 INCH,HEX<br>-----*           | 83385    | OBD              |
| -3               | 134-0067-00        |                      |        | 4   |           | . BUTTON,PLUG:GRAY PLASTIC                                | 80009    | 134-0067-00      |
| -4               | 213-0334-00        |                      |        | 2   |           | . SETSCREW:0.250-28 X 0.750 INCH,SOC STL                  | 56878    | OBD              |
| -5               | 351-0104-00        |                      |        | 1   |           | . SLIDE SECT.,DWR:PAIR<br>(ATTACHING PARTS)               | 06666    | C-720-2          |
| -6               | 212-0023-00        |                      |        | 2   |           | . SCREW,MACHINE:8-32 X 0.375 INCH,PNH STL                 | 83385    | OBD              |
| -7               | 210-0458-00        |                      |        | 2   |           | . NUT,PLAIN,EXT W:8-32 X 0.344 INCH,STL<br>-----*         | 83385    | OBD              |
| -8               | 210-0808-00        |                      |        | 2   |           | . EYELET,METALLIC:CENTERING<br>(ATTACHING PARTS FOR EACH) | 63743    | 2515113-3TP-909  |
| -9               | 211-0507-00        |                      |        | 1   |           | . SCREW,MACHINE:6-32 X 0.312 INCH,PNH STL                 | 83385    | OBD              |
| -10              | 210-0457-00        |                      |        | 1   |           | . NUT,PLAIN,EXT W:6-32 X 0.312 INCH,STL<br>-----*         | 83385    | OBD              |
| -11              | 386-2669-00        |                      |        | 1   |           | . SUPPORT,CABINET:REAR<br>(ATTACHING PARTS)               | 80009    | 386-2669-00      |
| -12              | 212-0023-00        |                      |        | 4   |           | . SCREW,MACHINE:8-32 X 0.375 INCH,PNH STL                 | 83385    | OBD              |
| -13              | 210-0458-00        |                      |        | 2   |           | . NUT,PLAIN,EXT W:8-32 X 0.344 INCH,STL<br>-----*         | 83385    | OBD              |
| -14              | 407-1350-00        |                      |        | 1   |           | . BRACKET,ANGLE:REAR<br>(ATTACHING PARTS)                 | 80009    | 407-1350-00      |
| -15              | 212-0023-00        |                      |        | 2   |           | . SCREW,MACHINE:8-32 X 0.375 INCH,PNH STL                 | 83385    | OBD              |
| -16              | 210-0458-00        |                      |        | 2   |           | . NUT,PLAIN,EXT W:8-32 X 0.344 INCH,STL<br>-----*         | 83385    | OBD              |
| -17              | 211-0517-00        |                      |        | 2   |           | . SCREW,MACHINE:6-32 X 1 INCH,PNH,STL                     | 83385    | OBD              |
| -18              | 212-0033-00        |                      |        | 4   |           | . SCREW,MACHINE:8-32 X 0.750 INCH,PNH STL                 | 83385    | OBD              |
| -19              | 437-0154-01        |                      |        | 1   |           | . CABINET,SCOPE:                                          | 80009    | 437-0154-01      |
| -20              | 351-0101-00        |                      |        | 1   |           | . SLIDE,DWR,EXT:PAIR                                      | 80009    | 351-0101-00      |
| -21              | 016-0099-00        |                      |        | 1   |           | . HDW KIT,ELEK EQ:                                        | 80009    | 016-0099-00      |

<sup>1</sup>Subpart on Standard Cabinet, 437-0141-00 only.

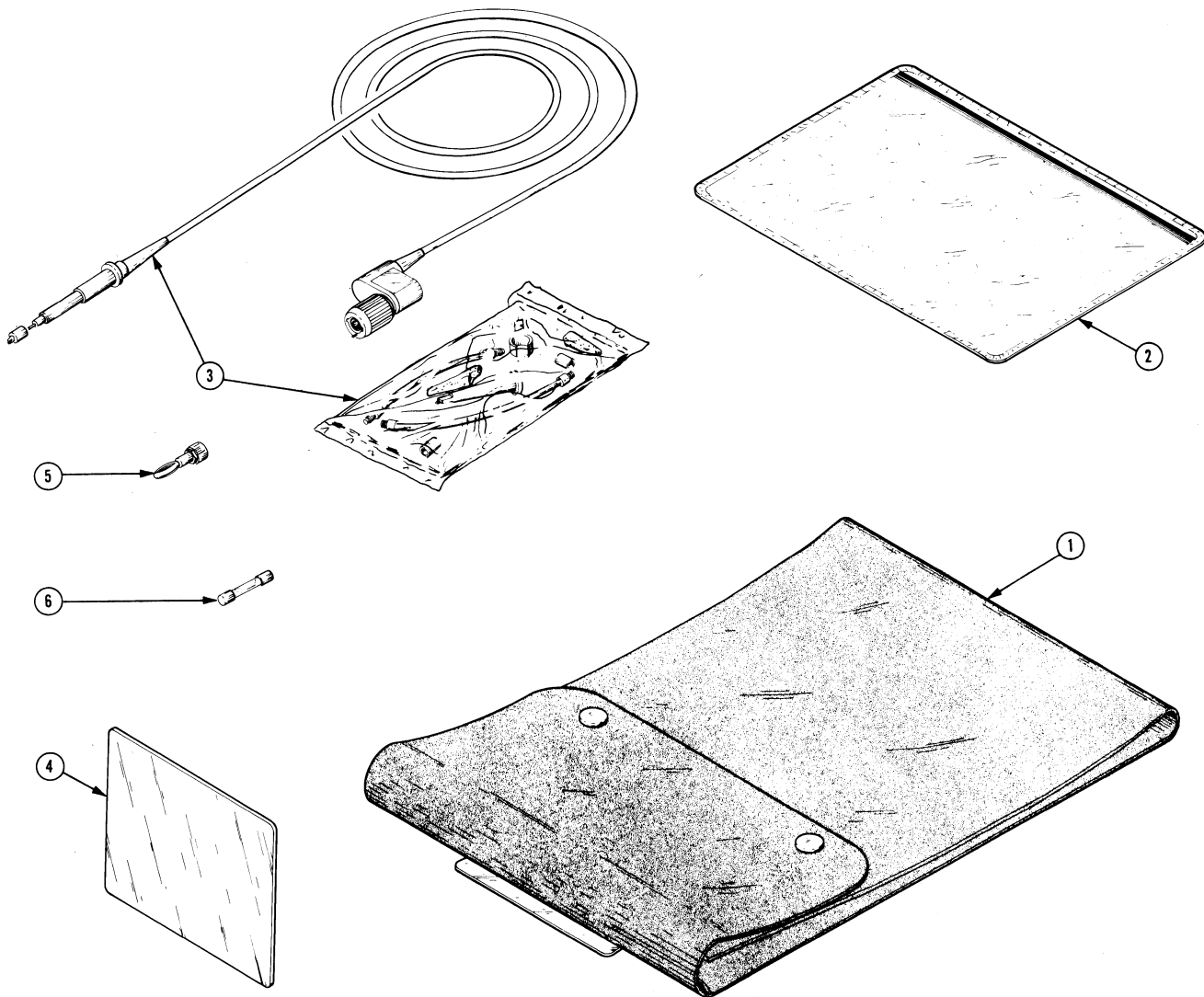

| Fig. & Index No. | Tektronix Part No. | Serial/Model No. Eff | Dscont  | Qty | 1 | 2 | 3 | 4 | 5 | Name & Description                             | Mfr Code | Mfr Part Number |
|------------------|--------------------|----------------------|---------|-----|---|---|---|---|---|------------------------------------------------|----------|-----------------|
| 4-1              | 016-0535-02        |                      |         | 1   |   |   |   |   |   | POUCH, ACCESSORY: W/HARDWARE, STANDARD         | 80009    | 016-0535-02     |
|                  | 016-0594-00        |                      |         | 1   |   |   |   |   |   | POUCH, ACCESSORY: W/HARDWARE, (WITH DM)        | 80009    | 016-0594-00     |
| -2               | 016-0537-00        |                      |         | 1   |   |   |   |   |   | POUCH, ACCESSORY: VINYL, W/ZIPPER              | 05006    | OBD             |
| -3               | 010-6065-13        | B250000              | B274999 | 2   |   |   |   |   |   | LEAD, TEST:                                    | 80009    | 010-6065-13     |
|                  | 010-6105-03        | B275000              |         | 2   |   |   |   |   |   | PROBE, VOLTAGE: P6105, 2 METER, 10X, W/ACCESS  | 80009    | 010-6105-03     |
|                  | 010-6430-00        |                      |         | 1   |   |   |   |   |   | LEAD, TEST: 1.5 METERS LONG, W/DM43 OR DM44    | 80009    | 010-6430-00     |
| -4               | 337-1674-01        |                      |         | 1   |   |   |   |   |   | SHLD, IMPLOSION: CLEAR                         | 80009    | 337-1674-01     |
| -5               | 134-0016-01        |                      |         | 1   |   |   |   |   |   | PLUG, TIP: W/BINDING POST                      | 80009    | 134-0016-01     |
| -6               | 159-0016-00        |                      |         | 2   |   |   |   |   |   | FUSE, CARTRIDGE: 3AG, 1.5A, 250V, FAST-BLOW    | 71400    | AGC 1 1/2       |
|                  | 159-0042-00        |                      |         | 2   |   |   |   |   |   | FUSE, CARTRIDGE: 3AG, 0.75A, 250V, FAST-BLOW   | 71400    | AGC 3/4         |
|                  | 003-0120-00        |                      |         | 1   |   |   |   |   |   | LEAD, TEST: PAIR (WITH DM)                     | 80009    | 003-0120-00     |
|                  | 070-1861-01        |                      |         | 1   |   |   |   |   |   | MANUAL, TECH: INSTRUCTION                      | 80009    | 070-1861-01     |
|                  | 070-1738-01        |                      |         | 1   |   |   |   |   |   | MANUAL, TECH: OPERATORS, W/DM43/DM40           | 80009    | 070-1738-01     |
|                  | 070-1779-00        |                      |         | 1   |   |   |   |   |   | MANUAL, TECH: SERVICE, DM43/DM40 (W/DM43/DM40) | 80009    | 070-1779-00     |
|                  | 070-2036-00        |                      |         | 1   |   |   |   |   |   | MANUAL, TECH: SERVICE, DM44                    | 80009    | 070-2036-00     |
|                  | 070-2038-00        |                      |         | 1   |   |   |   |   |   | MANUAL, TECH: OPERATORS W/DM44                 | 80009    | 070-2038-00     |

