

TEKTRONIX®

465 OSCILLOSCOPE

SERVICE

INSTRUCTION MANUAL

Tektronix, Inc.
P.O. Box 500
Beaverton, Oregon 97005

Serial Number _____

070-1330-00

1272



WARRANTY

All TEKTRONIX instruments are warranted against defective materials and workmanship for one year. Any questions with respect to the warranty should be taken up with your TEKTRONIX Field Engineer or representative.

All requests for repairs and replacement parts should be directed to the TEKTRONIX Field Office or representative in your area. This will assure you the fastest possible service. Please include the instrument Type Number or Part Number and Serial Number with all requests for parts or service.

Specifications and price change privileges reserved.

Copyright © 1972 by Tektronix, Inc., Beaverton, Oregon.
Printed in the United States of America. All rights reserved.
Contents of this publication may not be reproduced in any form without permission of Tektronix, Inc.

U.S.A. and foreign TEKTRONIX products covered by U.S. and foreign patents and/or patents pending.

TEKTRONIX is a registered trademark of Tektronix, Inc.

TABLE OF CONTENTS

SECTION 1	465 SPECIFICATIONS	Page
	Introduction	1-1
	Vertical Deflection System	1-1
	Triggering	1-1
	Horizontal Deflection System	1-2
	X-Y Operation	1-3
	Calibrator	1-3
	Z Axis Input	1-3
	Signal Outputs	1-3
	Power Source	1-3
	Cathode-Ray Tube	1-3
	Supplemental Information	
	General	1-3
	Vertical Deflection System	1-3
	Triggering	1-4
	Horizontal Deflection System	1-4
	Calibrator	1-4
	External Z Axis Input	1-4
	Output Signals	1-4
	Cathode-Ray Tube	1-4
SECTION 2	OPERATING INFORMATION	
	Introduction	2-1
	Instrument Repackaging	2-1
	Operating Voltage	2-1
	Controls And Connectors	
	General	2-2
	Cathode-Ray Tube (CRT) and Display	2-2
	Vertical Deflection System	2-2
	A and B Triggering	2-4
	A and B Sweep	2-5
	Calibrator and Power	2-6
	Rear Panel	2-6
	Obtaining Basic Displays	
	Introduction	2-6
	Normal Sweep Display	2-6
	Magnified Sweep Display	2-7
	Delayed Sweep Display	2-7
	Mixed Sweep Display	2-7
	X-Y Display	2-7
SECTION 3	CIRCUIT DESCRIPTION	
	Introduction	3-1
	Digital Logic	3-1
	Block Diagram	
	General	3-1
	Channel 1 Preamp	
	General	3-3
	Input Coupling	3-3
	Input Attenuator	3-4
	Scale-Factor Switching Circuit	3-4
	Source Follower Stage	3-4
	First Cascode Amplifier Stage	3-4
	Second Cascode Amplifier Stage	3-4
	Third Cascode Amplifier Stage	3-5
	Channel 2 Preamp	
	General	3-5
	Second Cascode Amplifier	3-5
	Third Cascode Amplifier	3-6

TABLE OF CONTENTS (cont)

SECTION 3	CIRCUIT DESCRIPTION (cont)	Page
	Vertical Switching Circuit	
	General	3-6
	Diode Gates	3-6
	Switching Multivibrator	3-7
	Delay-Line Driver	3-8
	Reference Feedback Amplifier	3-8
	Normal Trigger Pickoff Amplifier	3-8
	Vertical Output Amplifier	
	General	3-8
	Delay Line	3-9
	Output Amplifier	3-9
	A and B Trigger Generators	
	General	3-9
	Trigger Source	3-9
	Trigger Coupling	3-9
	Input Source Follower	3-9
	Paraphase Amplifier	3-9
	Tunnel Diode Driver	3-10
	A And B Sweep Generators	
	General	3-10
	Disconnect Amplifier	3-10
	Sawtooth Sweep Generator	3-11
	Output Buffer Amplifier	3-11
	Sweep Start Amplifier	3-11
	Logic Multivibrator	3-11
	B Sweep Generator Differences	3-11
	Sweep And Z Axis Logic Circuit	
	General	3-11
	A Sweep Gate	3-11
	B Sweep Gate	3-12
	Sweep Control Integrated Circuit	3-12
	A Sweep Holdoff Amplifier	3-13
	B Sweep Holdoff Amplifier	3-13
	A Sweep Z-Axis Gate	3-13
	B Sweep Z-Axis Gate	3-13
	+A GATE And +B GATE Emitter Followers	3-13
	B Sweep Latch	3-14
	Horizontal Amplifier	
	General	3-14
	X-Axis Amplifier	3-14
	Input Paraphase Amplifier	3-15
	Gain Setting Amplifier	3-15
	Output Amplifier	3-15
	CRT Circuit	
	General	3-15
	High-Voltage Oscillator	3-16
	High-Voltage Regulator	3-16
	High-Voltage Rectifiers and Output	3-17
	CRT Control Circuits	3-17
	Z-Axis Amplifier	3-17
	DC Restorer Circuit	3-17
	Calibrator	
	General	3-18
	Multivibrator	3-18
	Output Amplifier	3-18
	A Trigger View Amplifier	
	General	3-18
	Amplifier	3-18

TABLE OF CONTENTS (cont)

SECTION 3	CIRCUIT DESCRIPTION (cont)	Page
	Low-Voltage Power Supply	
	General	3-19
	Power Input	3-20
	Secondary Circuit	3-20
	Fan Motor Circuit	
	General	3-20
SECTION 4	MAINTENANCE	
	Cabinet Removal	4-1
	Preventive Maintenance	
	General	4-1
	Cleaning	4-1
	Lubrication	4-2
	Transistors Checks	4-2
	Recalibration	4-2
	Corrective Maintenance	
	General	4-2
	Obtaining Replacement Parts	4-2
	Soldering Techniques	4-3
	Component Replacement	4-3
	Recalibration After Repair	4-5
	Instrument Repackaging	4-6
SECTION 5	CALIBRATION	
	Calibration Interval	5-1
	TEKTRONIX Field Service	5-1
	Using This Procedure	5-1
	Test Equipment Required	5-1
	Performance Check	
	Vertical System Check	5-6
	Trigger System Check	5-11
	Horizontal System Check	5-13
	Short-Form Calibration	
	Power Supplies And Display	5-16
	Vertical System	5-17
	Trigger System	5-19
	Horizontal System	5-21
	Detailed Calibration	
	Power Supply	5-27
	Display & Z-Axis	5-28
	Vertical System	5-30
	Trigger System	5-43
	Horizontal System	5-53
	Calibrator, Gates, & Ext Z-Axis	5-60
SECTION 6	ELECTRICAL PARTS LIST	
SECTION 7	DIAGRAMS & CIRCUIT BOARD ILLUSTRATIONS	
SECTION 8	MECHANICAL PARTS LIST, ACCESSORIES AND PACKAGING	
	CHANGE INFORMATION	

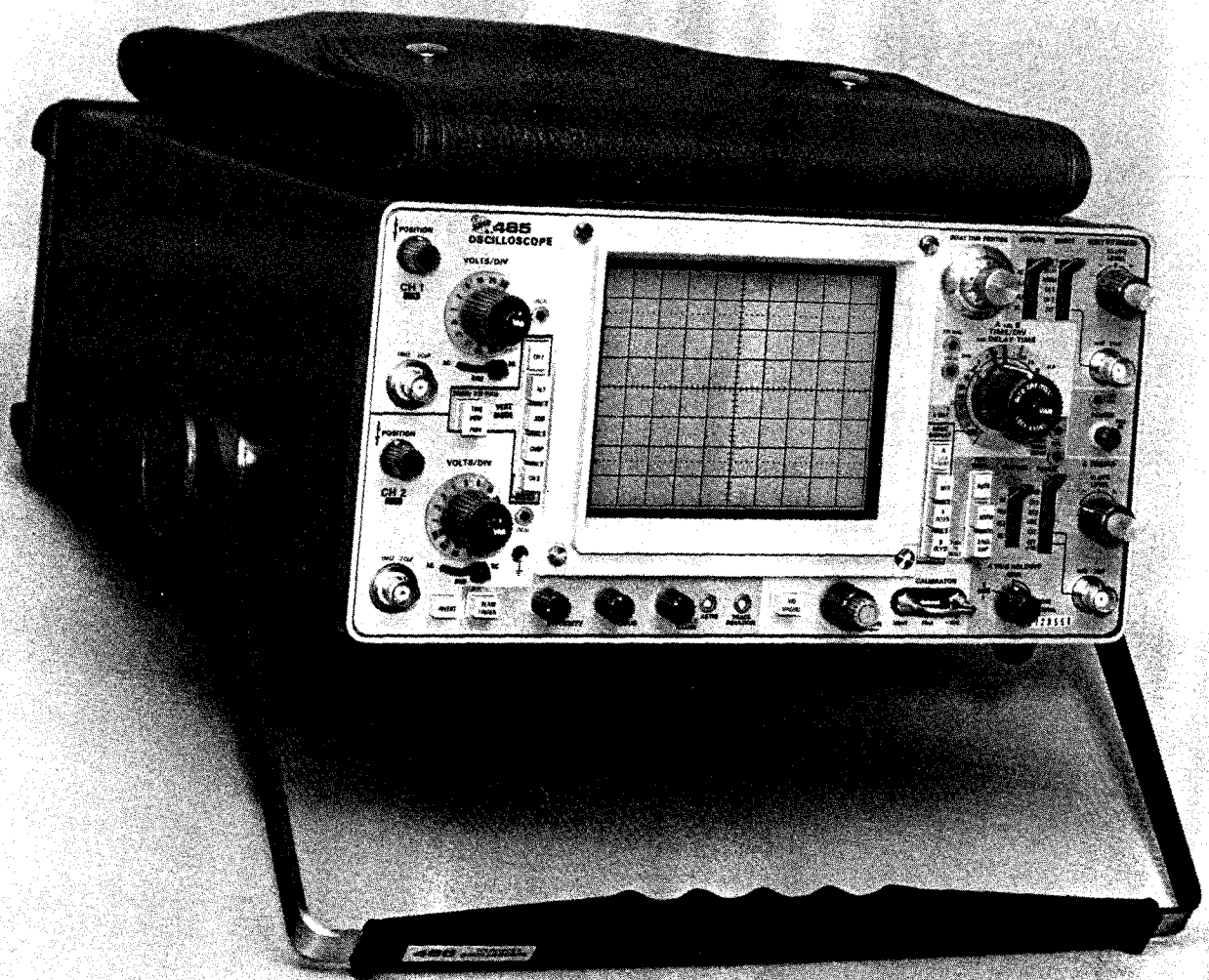

Fig. 1-1. 465 Oscilloscope.

465 SPECIFICATIONS

Introduction

The 465 Oscilloscope is a wide-band, portable oscilloscope designed to operate in a wide range of environmental conditions. The instrument is light in weight and compact of design for ease of transportation, yet capable of performance necessary for accurate high-frequency measurements. The dual-channel, DC-to-100 megahertz vertical deflection system provides calibrated deflection factors from 5 millivolts to 5 volts/division. The bandwidth limiting switch reduces interference from signals above about 20 megahertz for viewing low-frequency, low-level signals.

The trigger circuits provide stable sweep triggering to beyond the bandwidth of the vertical deflection system. Separate controls are provided to select the desired mode of triggering for the A and B sweeps. The A sweep can be operated in one of three modes: automatic triggering, normal triggering, or single sweep. A variable trigger holdoff control provides the ability for A sweep to trigger stably on aperiodic signals or complex digital words. The horizontal deflection system has calibrated sweep rates from 0.5

second to 0.05 microsecond/division. A X10 magnifier increases each sweep rate by a factor of 10 to provide a maximum sweep rate of 5 nanoseconds/division in the 0.05 μ s position. The delayed and mixed sweep features allow the start of the B sweep to be delayed a selected amount from the start of A sweep to provide accurate relative-time measurements. Calibrated X-Y measurements can be made with Channel 2 providing the vertical deflection and Channel 1 providing the horizontal deflection (TIME/DIV switch fully counterclockwise and VERT MODE switch to CH 2). The regulated DC power supplies ensure that instrument performance is not affected by variations in line voltage and frequency. Maximum power consumption of the instrument is approximately 75 watts.

The following instrument specifications apply over an ambient temperature range of -15°C to $+55^{\circ}\text{C}$ unless otherwise specified. Warm-up time for specified accuracies is 20 minutes. The calibration procedure given in section 5, if performed completely, will allow an instrument to meet the electrical characteristics listed below.

VERTICAL DEFLECTION SYSTEM

Deflection Factor

Calibrated range is from 5 millivolts to 5 volts per division in 10 steps in a 1-2-5 sequence. Accuracy is within 3%. Uncalibrated VAR control provides deflection factors continuously variable between the calibrated settings, and extends deflection factor to at least 12.5 volts per division in the 5 volts/div position.

Frequency Response

Bandwidth in both Channel 1 and Channel 2 is DC to at least 100 megahertz. Risetime is 3.5 nanoseconds or less. The AC-coupled lower -3 dB point is 10 hertz or less (1 hertz or less when using a 10X probe). Vertical system bandwidth with the BW LIMIT pushbutton pulled is approximately 20 megahertz.

Chopped Mode Repetition Rate

Approximately 250 kilohertz.

Input Resistance And Capacitance

One megohm within 2% paralleled by approximately 20 picofarads.

Maximum Input Voltage

DC coupled: 250 V (DC + Peak AC) or 500 V P-P AC at 1 kHz or less.

AC coupled: 500 V (DC + Peak AC) or 500 V P-P AC at 1 kHz or less.

Cascaded Operation (CH 1 VERT SIGNAL OUT Connected to CH 2 OR Y)

Bandwidth is DC to at least 50 MHz with a sensitivity of at least 1 mV/division.

TRIGGERING

Sensitivity

DC Coupled: 0.3 division internal or 50 millivolts external from DC to 25 megahertz, increasing to 1.5 divisions internal or 150 millivolts external at 100 megahertz.

AC Coupled: 0.3 division internal or 50 millivolts external from 60 hertz to 25 megahertz, increasing to 1.5 divisions internal or 150 millivolts external at 100 megahertz. Attenuates all signals below about 60 hertz.

Specifications—465

LF REJ Coupled: 0.5 division internal or 100 millivolts external from 50 kilohertz to 25 megahertz, increasing to 1.5 divisions internal or 300 millivolts external at 100 megahertz. Blocks DC and attenuates all signals below about 50 kilohertz.

HF REJ Coupled: 0.5 division internal or 100 millivolts external from 60 hertz to 50 kilohertz. Blocks DC and attenuates all signals below about 60 hertz and above about 50 kilohertz.

Trigger Jitter

0.5 nanosecond or less at 5 nanoseconds/division with 100 megahertz applied (X10 MAG on).

External Trigger Input

Maximum input voltage is 250 V DC + peak AC or 250 V P-P AC (1 kilohertz or less). Input resistance is 1 megohm within 10%.

LEVEL Control Range

EXT: At least + and - 2 volts, 4 volts peak to peak.

EXT ÷10: At least + and - 20 volts, 40 volts peak to peak.

HORIZONTAL DEFLECTION SYSTEM

Calibrated Sweep Range

A Sweep: from 0.5 second/division to 0.05 microsecond/division in 22 steps in a 1-2-5 sequence. X10 MAG extends maximum sweep rate to 5 nanoseconds/division.

B Sweep: from 50 milliseconds/division to 0.05 microsecond/division in 19 steps in a 1-2-5 sequence. X10 MAG extends maximum sweep rate to 5 nanoseconds/division.

Calibrated Sweep Accuracy

Unmagnified sweep accuracy is ±2% from +20°C to +30°C (+68°F to +86°F) and ±3% from -15°C to +20°C and +30°C to +55°C (+5°F to +68°F and +86°F to +131°F). For the same temperature ranges, magnified sweep accuracy is ±3% and ±4% respectively. Exclude the first and last 50 ns of the 5 ns, 10 ns, and 20 ns magnified sweep rates. Accuracy specifications apply over full ten divisions unless otherwise specified.

Sweep accuracy, over any two or less division portion of the sweep, is ±5%. Exclude the first and last magnified divisions of the 5 ns and 10 ns/div magnified sweep rates. Also exclude the first and last 50 ns of the 5, 10, and 20 ns/div magnified sweep rates.

Mixed sweep accuracy is 2% plus the measured A sweep error when viewing the A sweep portion only. The B sweep portion retains its normal accuracy.

A Time/Division Variable Range

Provides continuously variable (uncalibrated) sweep rates between the calibrated settings of the A TIME/DIV switch. Extends the slowest A sweep rate to at least 1.25 seconds/division.

A Trigger Holdoff

Increases A sweep holdoff time by at least a factor of 10.

Delay Time And Differential Time Measurement Accuracy

	+15°C to +35°C (+60°F to +95°F)	-15°C to +55°C (+5°F to +131°F)
Over One Or More Major Dial Division	±1%	±2.5%
Over Less Than One Major Dial Division	±0.01 Major Dial Division	±0.03 Major Dial Division

Delay Time Jitter

Within 0.002% (less than one part in 50,000) of the maximum available delay time when operating on power line frequencies other than 50 Hz.

Within 0.005% (less than one part in 20,000) of the maximum available delay time when operating on 50 Hz power line frequency.

Maximum available delay time is ten times the setting of the A TIME/DIV switch.

Calibrated Delay Time (A VAR set to calibrated position)

Continuous from 5 seconds to 0.2 microsecond.

X-Y OPERATION**Sensitivity**

Same as vertical deflection system.

X Axis deflection accuracy within 4%.

Variable Range

Same as vertical deflection system.

X-Axis Bandwidth

DC to at least 4 megahertz.

Y-Axis Bandwidth

Same as vertical deflection system.

Input Resistance

Same as vertical deflection system.

Input Capacitance

Same as vertical deflection system.

Maximum Usable Input Voltage

Same as vertical deflection system.

CALIBRATOR**Output**

An approximate 1 kilohertz frequency 30 milliampere ($\pm 2\%$), 300 millivolt ($\pm 1\%$) square-wave signal.

Z AXIS INPUT**Sensitivity**

A 5-volt peak to peak signal causes noticeable modulation at normal intensity.

Usable Frequency Range

From DC to 50 megahertz.

SIGNAL OUTPUTS**CH 1 VERT SIGNAL OUT**

Output voltage is at least 50 millivolts/division into a 1 megohm load (at least 25 millivolts/division into a 50 ohm load).

Bandwidth is from DC to at least 50 megahertz into a 50 ohm load.

Output DC level is approximately zero volts.

A and B +GATE Outputs

Output voltage is approximately 5.5 volts, positive-going.

POWER SOURCE**Line Voltages**

110, 115, 120, 220, 230, or 240 VAC (all $\pm 10\%$), depending on the settings of the Line Voltage Selector switch and the Regulating Range Selector assembly, with a line frequency of 48 to 440 hertz. Maximum power consumption is 75 watts at 115 VAC, 60 hertz.

CATHODE-RAY TUBE**Graticule Area**

Eight by ten centimeters.

Phosphor

P31 is the standard phosphor with P11 offered as an option.

SUPPLEMENTAL INFORMATION**General**

The supplemental information listed here represents limits that, when met, ensure optimum instrument operation. They are, however, not instrument specifications but are intended to be used only as maintenance or operational aids.

VERTICAL DEFLECTION SYSTEM**Low-Frequency Linearity**

There should be no more than 0.1 division of compression or expansion of a two-division signal at center screen when the signal is positioned to the upper and lower extremes of the CRT graticule area.

Bandwidth Limiter Bandwidth

The -3 dB point should be between 15 and 25 megahertz.

Step Response Aberrations

At 5 V/DIV there should be no more than +4%, -4%, 4% P-P. For all other ranges there should be no more than +3%, -3%, or a total of 3% peak to peak aberration on a positive-going step. Position-effect should not cause total aberrations to be more than +5%, -5%, or a total of 5% peak to peak.

Common-Mode Rejection Ratio

At least 10:1 at 20 megahertz for common mode signals of 6 divisions or less with vertical gain adjusted for best CMRR at 50 kilohertz.

Step Attenuator Balance

Adjustable to 0.2 division or less of trace shift when switching between adjacent deflection factors.

Trace Shift As Variable Is Rotated

Adjustable to one division or less.

INVERT Trace Shift

Two divisions or less when switching from normal to inverted.

Input Gate Current

0.5 nanoampere or less (0.1 division of deflection at 5 mV/div) from +20°C to +30°C. Four nanoamperes or less (0.8 division of deflection at 5 mV/div) from -15°C to +55°C.

Channel Isolation

At least 100:1 at 25 megahertz.

Position Control Range

Twelve divisions up and twelve divisions down from graticule center.

TRIGGERING

External Trigger Input Capacitance

Twenty picofarads within 30%.

HORIZONTAL DEFLECTION SYSTEM

A Sweep Length

10.5 to 11.5 divisions.

Magnifier Registration

There should be 0.2 division or less difference at graticule center when switching from MAG on to MAG off.

Position Control Range

Should be able to position the start of the sweep to the right of graticule center, and the end of the sweep to the left of graticule center.

Phase Difference Between X And Y Axes Amplifiers

Typically 3° or less from DC to 50 kilohertz.

CALIBRATOR

Repetition Rate

Repetition rate accuracy is typically within 25%.

Output Resistance

Approximately 9.4 ohms.

EXTERNAL Z AXIS INPUT

Maximum Input Voltage

Voltages applied to the EXT Z AXIS INPUT connector should be limited to less than 100 volts DC plus peak AC or 100 volts peak to peak AC at 1 kilohertz or less.

OUTPUT SIGNALS

Output Resistance

Output resistance of the CH 1 VERT SIG OUT connector is $\approx 50 \Omega$.

Output resistance of +A and +B GATE outputs is $\approx 500 \Omega$.

CATHODE-RAY TUBE

Resolution

Typically at least 15 lines per division horizontally and vertically.

Geometry

0.1 division or less of tilt or bowing.

Raster Distortion

0.1 division or less.

Nominal Accelerating Potential

Approximately 18,500 volts.

OPERATING INFORMATION

Introduction

This section of the manual is intended to allow the operator to become familiar with the instrument power requirements, functions of controls and connectors, and how to obtain a few basic displays. For more complete operating information, refer to the 465 Operators Handbook.

Instrument Repackaging

If this instrument is to be shipped for long distances by commercial means of transportation, it is recommended that it be repackaged in the original manner for maximum protection. The original shipping carton can be saved and used for this purpose. Fig. 5 in the Mechanical Parts List illustrates how to repackage the 465 and gives the part number for the packaging components. New shipping cartons can be obtained from Tektronix, Inc. Contact your local TEKTRONIX Field Office or representative.

Operating Voltage

CAUTION

This instrument is designed for operation from a power source with its neutral at or near earth (ground) potential with a separate safety-earth conductor. It is not intended for operation from two phases of a multi-phase system, or across the legs of a single-phase three-wire system.

This instrument can be operated from either a 115-volt or 230-volt nominal line voltage source, 48 to 440 hertz. The Line Voltage Selector switch in the instrument converts the instrument from one nominal operating voltage to the other. The Regulating Range Selector assembly on the instrument rear panel selects one of three regulating ranges for each nominal line voltage; it also contains the line fuse for overload protection. To select the correct nominal line voltage and regulating range, proceed as follows:

1. Disconnect the instrument from the power source.

2. To convert from 115-volts nominal to 230-volts nominal line voltage, set the selector switch to the 230 volts position (toward the rear of the instrument). Change the line-cord plug to match the power source or use a 115-to-230 volt adapter.

NOTE

Color-coding of the cord conductors is as follows (in accordance with National Electrical Code):

<i>Line</i>	<i>Black</i>
<i>Neutral</i>	<i>White</i>
<i>Safety earth (ground)</i>	<i>Green (or green with yellow tracer)</i>

3. To change regulating ranges, loosen the two captive screws which hold the cover onto the Regulating Range Selector assembly, then pull to remove the cover.

4. Pull out the range selector switch bar (see Fig. 2-1). Slide the bar to the desired position and plug it back in. Select a range which is centered about the average line voltage to which the instrument is to be connected (see Table 2-1).

TABLE 2-1

Regulating Ranges

Range Selector Switch Position	Regulating Range	
	115-Volts Nominal	230-Volts Nominal
Lo (switch bar in bottom holes)	99 to 121 volts	198 to 242 volts
M (switch bar in middle holes)	104 to 126 volts	208 to 252 volts
HI (switch bar in top holes)	108 to 132 volts	216 to 264 volts

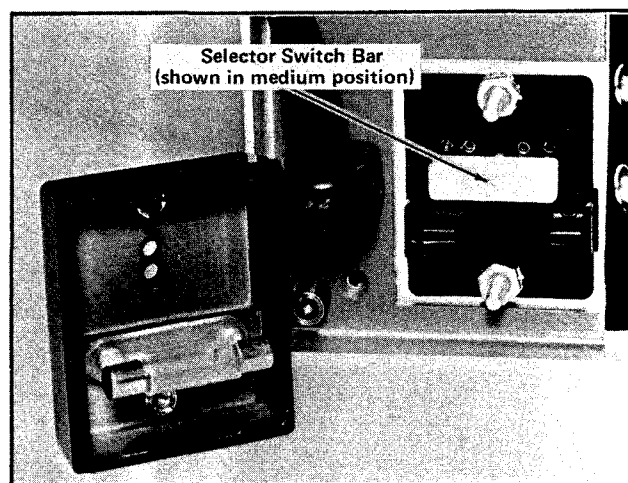

Fig. 2-1. Power supply regulating range selector.

Operating Information—465

5. Re-install the cover and tighten the two captive screws.

6. Before applying power to the instrument, check that the line voltage selector switch and the indicating tab on the Regulating Range Selector assembly are in the correct position for the desired nominal line voltage and regulating range.

CAUTION

This instrument may be damaged if operated with the line voltage selector switch or the Regulating Range Selector assembly set to incorrect positions for the line voltage applied.

The 465 is designed to be used with a three-wire AC power system. If a three-to two-wire adapter is used to connect this instrument to a two-wire AC power system, be sure to connect the ground lead of the adapter to earth (ground). Failure to complete the ground system may allow the chassis of this instrument to be elevated above ground potential and pose a shock hazard.

The feet on the rear panel provide a convenient cord wrap to store the power cord when not in use.

CONTROLS AND CONNECTORS

General

The major controls and connectors for operation of the 465 are located on the front panel of the instrument. A few auxiliary functions are provided on the rear panel. Fig. 2-2 shows the front and rear panels of the 465. A brief description of each control and connector is given here. More detailed operating information is given in the 465 Oscilloscope Operators Handbook.

Cathode-Ray Tube (CRT) and Display

BEAM FIND	Compresses the display to within the graticule area, independently of display position or applied signals.
INTENSITY	Controls brightness of the display.
FOCUS	Provides adjustment for optimum display definition.
SCALE ILLUM	Controls graticule brightness.

ASTIG Screwdriver adjustment used in conjunction with the FOCUS control to obtain a well-defined display. Does not require readjustment in normal use.

TRACE ROTATION Screwdriver adjustment to align the trace with the horizontal graticule lines.

Vertical Deflection System (Channel 1 & Channel 2)

POSITION Controls the vertical position of the trace. In the X-Y mode of operation, the CH 2 control positions on the Y-axis (vertically) and the Horizontal POSITION control positions on the X-axis (horizontally).

CH 1 OR X Input connector for Channel 1 deflection signals or X-axis deflection in the X-Y mode of operation.

CH 2 OR Y Input connector for Channel 2 deflection signals or Y-axis deflection in the X-Y mode of operation.

GAIN (Side Panel) Screwdriver adjustment to set the gain of the Vertical Preamp.

VOLTS/DIV Selects vertical deflection factor in a 1-2-5 sequence (VAR control must be in the calibrated detent for the indicated deflection factor).

VAR Provides continuously variable uncalibrated deflection factors between the calibrated settings of the VOLTS/DIV switch.

UNCAL Light indicates that the VAR control is not in the calibrated position.

Input Coupling (AC-GND-DC) Selects the method of coupling signal to the input of the Vertical Amplifier.

AC: Signal is capacitively coupled to the Vertical Amplifier. DC component of signal is blocked. Low-frequency limit (lower -3 dB point) is about 10 hertz.

GND: Input signal is removed and the input circuit is grounded. Does not ground the input signal.

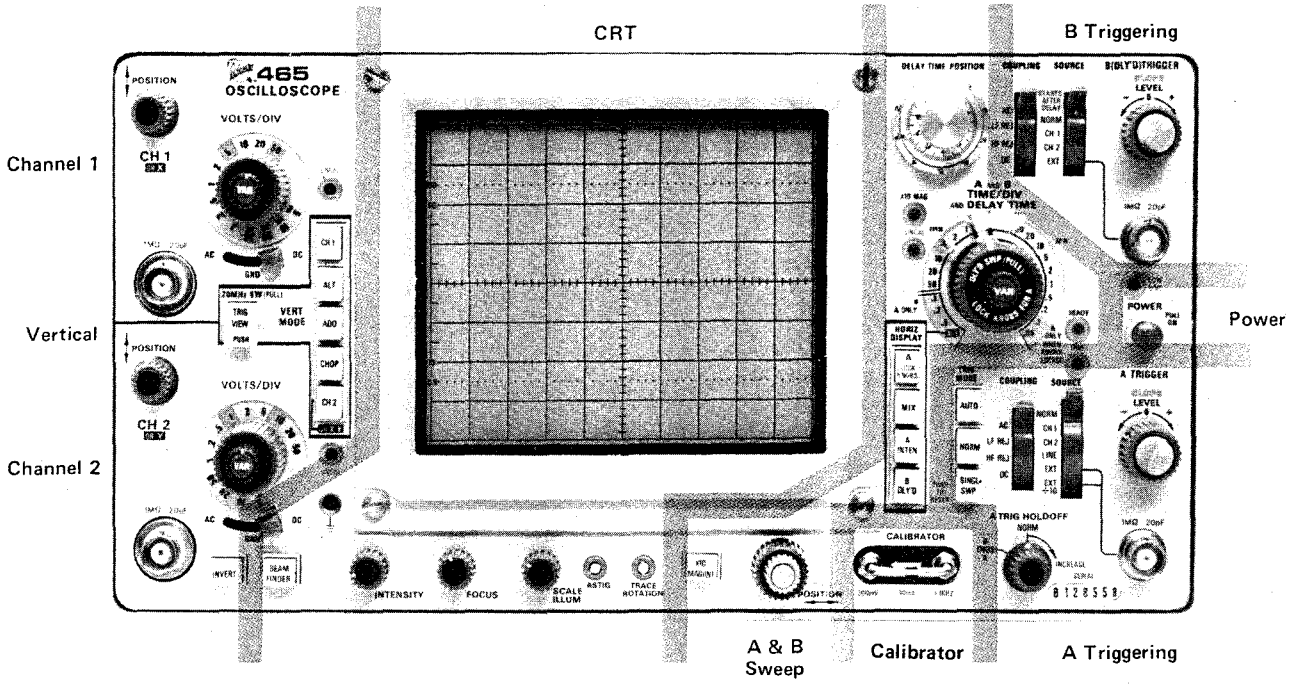

A. Front panel.

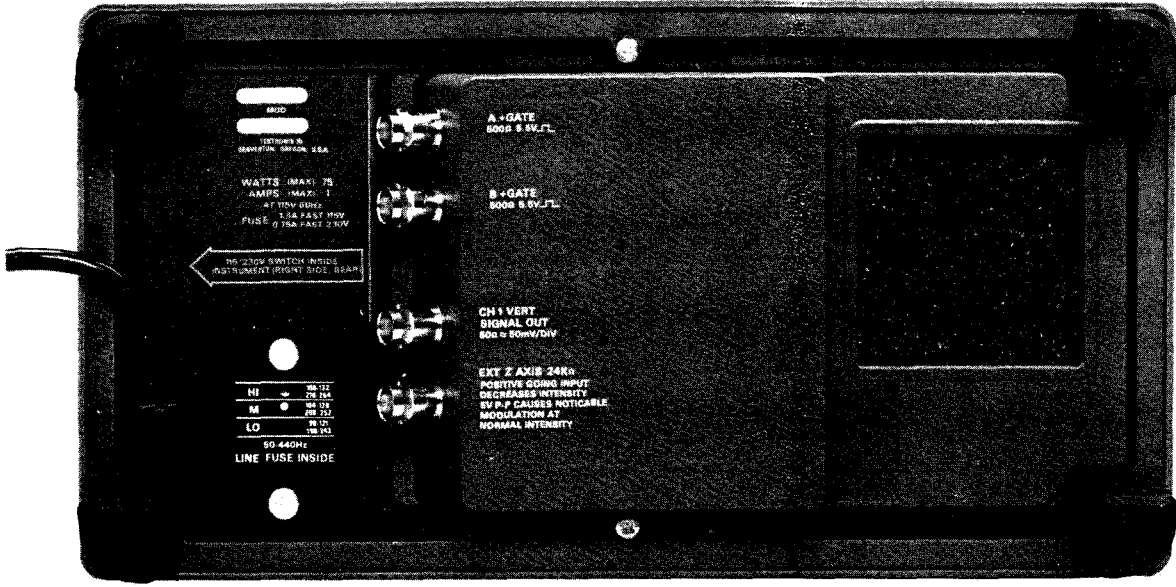

B. Rear panel.

Fig. 2-2. Front- and rear-panel controls and connectors.

	DC: All components of the input signal are passed to the Vertical Amplifier.		HF REJ: Accepts signals between 60 Hz and 50 kHz. Rejects DC and attenuates all signals outside the above range.
20 MHz BW/TRIG VIEW	Dual-purpose switch that, when pulled out, limits the bandwidth of the complete Vertical Deflection System to approximately 20 MHz, or when pressed causes signal present in A Trigger Generator circuit to be displayed on the CRT.	SOURCE	DC: Accepts all trigger signals from DC to 100 MHz or greater. Selects source of trigger signal. NORM: Internal trigger signal obtained from Vertical Deflection System. Actual source is signal(s) displayed on CRT. CH 1: A sample of the signal connected to the CH 1 OR X input connector is used as a trigger signal. CH 2: A sample of the signal connected to the CH 2 OR Y input connector is used as a trigger signal. EXT: Trigger signal is obtained from signal connected to the External Trigger Input connector. EXT ÷10 (A trigger circuit only): External trigger signal is attenuated by a factor of 10. STARTS AFTER DELAY (B trigger circuit only): B sweep starts immediately after the delay time selected by the DELAY-TIME POSITION dial and the DELAY-TIME switch. LINE (A trigger circuit only): Trigger signal is obtained from a sample of the line voltage applied to the instrument.
INVERT	Pushbutton switch that inverts the Channel 2 display.		
VERT MODE	Selects the vertical mode of operation. CH 1: Displays Channel 1 only. ALT: Dual-trace display of signals on both channels. Display is switched between channels at the end of each sweep. ADD: Signals applied to the CH 1 OR X and CH 2 OR Y connectors are algebraically added and the sum is displayed on the CRT. The INVERT switch in Channel 2 allows the display to be CH 1 + CH 2 or CH 1 - CH 2. CHOP: Dual-trace display of signals on both channels. Display is switched between channels at an approximate repetition rate of 250 kHz. CH 2 OR X-Y: Displays Channel 2 only. Must be pushed when operating in X-Y mode.		
A and B Triggering (both where applicable)		SLOPE	Selects the slope of the trigger signal which starts the sweep. +: Sweep can be triggered from the positive-going portion of the trigger signal. -: Sweep can be triggered from the negative-going portion of the trigger signal.
COUPLING	Determines the method used to couple signal to input of trigger circuits. AC: Rejects DC and attenuates signals below about 60 Hz. Accepts signals above about 60 Hz. LF REJ: Rejects DC and attenuates signals below about 50 kHz. Accepts signals above about 50 kHz.	LEVEL	Selects the amplitude point on the trigger signal at which the sweep is triggered.

A TRIG MODE

Determines the operating mode for the A Trigger Circuit.

AUTO: With the proper trigger control settings, A Sweep can be initiated by signals that have repetition rates above about 20 hertz and are within the frequency range selected by the COUPLING switch. In the absence of an adequate trigger signal or when the trigger controls are misadjusted, the sweep free-runs to produce a reference trace.

NORM: With the proper trigger control settings, A Sweep can be initiated by signals that are within the frequency range selected by the COUPLING switch. In the absence of an adequate trigger signal or when the trigger controls are misadjusted, there is no trace.

SING SWP: After a sweep is displayed, further sweeps cannot be presented until the SING SWP pushbutton is pressed again. The display is triggered the same as for NORM operation using the A Triggering controls.

A TRIG HOLDOFF

Provides control of holdoff time between sweeps to obtain stable displays when triggering on aperiodic signals (such as complex digital words). Variable can increase holdoff time up to at least 10 times the holdoff time of the NORM position. In the B ENDS A position (fully clockwise), the A sweep is reset at the end of the B sweep to provide the fastest possible sweep repetition rate for delayed sweep presentations.

External Trigger Input (not labeled)

Input connectors for external trigger signals.

A and B Sweep

DELAY-TIME POSITION

Provides variable sweep delay between 0.20 and 10.20 times the delay time indicated by the DELAY TIME switch.

A AND B TIME/DIV AND DELAY TIME

A TIME/DIV switch (clear plastic outer flange) selects the sweep rate of the A sweep circuit and selects the basic delay time (to be multiplied by DELAY-TIME POSITION dial setting) for delayed-sweep operation. B TIME/DIV switch (inner dark knob) selects sweep rate of the B sweep circuit for delayed sweep operation only. VAR control must be in calibrated detent for calibrated A sweep rates.

VAR

Provides continuously variable A sweep rates between the calibrated settings of the A TIME/DIV switch. The A sweep rate is calibrated when the VAR control is fully clockwise into the calibrated detent.

UNCAL

Light that indicates when the VAR TIME/DIV control is out of the calibrated detent and the horizontal sweep rate is uncalibrated.

X10 MAG Indicator

Light that indicates when the X10 MAG is turned on.

READY

Light that indicates that A Sweep has been prepared to present a single sweep upon receipt of an adequate trigger signal.

HORIZ DISPLAY

Selects the horizontal mode of operation.

A: Horizontal deflection provided by A Sweep. B Sweep inoperative.

MIX: The first part of the horizontal sweep is displayed at a rate set by the A TIME/DIV switch and the latter part of the sweep at a rate set by the B TIME/DIV switch. Relative amounts of the display allocated to each of the two rates are determined by the setting of the DELAY-TIME POSITION dial.

A INT: Displayed sweep rate determined by the A TIME/DIV switch. An intensified portion appears on the display during the B sweep time. This switch position provides a check of the duration and position of the B sweep (delayed sweep) with respect to the delaying sweep (A).

B DLYD: Sweep rate determined by the B TIME/DIV switch with the delay time determined by the setting of the DELAY TIME (A TIME/DIV) switch and the DELAY-TIME POSITION dial.

Horizontal POSITION Positions the display horizontally.
 X10 MAG Increases the displayed sweep rate by a factor of 10.

Calibrator and Power

CALIBRATOR A combination current loop and square-wave voltage output device. Provides a 30 mA square-wave current, 300 mV square-wave voltage signal with a repetition rate of approximately 1 kHz.
 POWER Turns instrument power on and off.
 LOW LINE Light that indicates the applied line voltage is below the lower limit of the regulating range selected by the Regulating Range Selector assembly.

Rear Panel

A +GATE Output connector providing a positive-going rectangular pulse coincident with the A sweep time.
 B +GATE Output connector providing a positive-going rectangular pulse coincident with the B sweep time.
 CH 1 VERT SIGNAL OUT Output connector providing a sample of the signal applied to the CH 1 input connector.
 EXT Z AXIS INPUT Input connector for intensity modulation of the CRT display.
 Regulating Range Selector Selects the regulating range of the internal power supplies (low, medium, high; determined by specific line voltage applied to instrument).

OBTAINING BASIC DISPLAYS

Introduction

The following instructions will allow the operator who is unfamiliar with the operation of the 465 to obtain the basic

displays commonly used. Before proceeding with these instructions, preset the instrument controls as follows:

Vertical Controls

VERT MODE Switch	CH 1
VOLTS/DIV Switches	Proper position determined by amplitude of signal to be applied.
VOLTS/DIV VAR Controls	Calibrated detent
Input Coupling Switches	AC
Vertical POSITION Controls	Midrange
20 MHz BW Switch	Not limited
INVERT Switch	Button out
INTENSITY Control	Fully counterclockwise
FOCUS Control	Midrange
SCALE ILLUM Control	Midrange

Trigger Controls (both A and B if applicable)

SLOPE Switch	+
LEVEL Control	0
SOURCE Switch	NORM
COUPLING Switch	AC
TRIG MODE Switch	AUTO
A TRIG HOLDOFF Control	NORM

Horizontal Sweep Controls

TIME/DIV Switches	Locked together at 1 ms
A TIME/DIV VAR	Calibrated detent
HORIZ DISPLAY Switch	A
X10 MAG Switch	Off (button out)
POSITION Control	Midrange

Normal Sweep Display

1. Set the POWER switch to on (button out). Allow several minutes for instrument warmup.
2. Connect the external signal to the CH 1 input connector.
3. Advance the INTENSITY control until the display is visible. If the display is not visible with the INTENSITY control at midrange, press the BEAM FIND pushbutton and adjust the CH 1 VOLTS/DIV switch until the display is reduced in size vertically. Then, center the compressed display with the vertical and horizontal POSITION controls, and release the BEAM FIND pushbutton. Adjust the FOCUS control for a well-defined display.
4. Set the CH 1 VOLTS/DIV switch and CH 1 POSITION control for a display which remains in the display area vertically.

5. Adjust the A Trigger LEVEL control for a stable display.

6. Set the A TIME/DIV switch and the horizontal POSITION control for a display which remains in the display area horizontally.

Magnified Sweep Display

1. Preset the instrument controls and follow steps 1 through 6 for obtaining a Normal Sweep Display.

2. Adjust the horizontal POSITION control to move the area to be magnified to within the center graticule division of the CRT. If necessary, change the TIME/DIV switch setting so the complete area to be magnified is within the center division.

3. Set the X10 MAG switch to the on position (button in) and adjust the horizontal POSITION control for precise positioning of the magnified display.

Delayed Sweep Displays

1. Preset the instrument controls and follow steps 1 through 6 for obtaining a Normal Sweep Display.

2. Set the HORIZ DISPLAY switch to A INT and the B Trigger SOURCE switch to STARTS AFTER DELAY.

3. Pull out the B TIME/DIV switch knob and turn clockwise so the intensified zone on the display is the desired length. Adjust the INTENSITY control to achieve the desired display brightness.

4. Adjust the DELAY-TIME POSITION dial to position the intensified zone to the portion of the display to be delayed.

5. Set the HORIZ DISPLAY switch to B DLYD. The intensified zone on the display noted in step 3 is now being displayed in delay form. The delayed sweep rate is indicated by the dot on the B TIME/DIV switch knob.

6. For a delayed sweep display that will exhibit less jitter, set the B Trigger SOURCE switch to the same position as the A Trigger SOURCE switch and adjust the B Trigger LEVEL control for a stable display. If the A Trigger SOURCE switch is in the LINE position, a sample of the line voltage will have to be supplied to the B Trigger circuit externally.

Mixed Sweep Display

1. Preset the instrument controls and follow steps 1 through 6 for obtaining a Normal Sweep Display.

2. Pull out on the B TIME/DIV switch knob and turn clockwise to the desired sweep rate. Adjust the INTENSITY control to achieve the desired display brightness.

3. Set the HORIZ DISPLAY switch to MIX. The CRT display now contains more than one time factor on the horizontal axis. The first portion of the display is at the A Time Base sweep rate and the latter part is at the B Time Base sweep rate. The start of the B Time Base portion of the display can be changed by adjusting the DELAY-TIME POSITION control.

X-Y Display

1. Preset the instrument controls and turn the instrument power on. Allow several minutes for instrument warm-up.

2. Set the TIME/DIV switch to X-Y and the VERT MODE to CH 2. Apply the vertical signal to the CH 2 or Y input connector and the horizontal signal to the CH 1 or X input connector. The CH 2 POSITION control will provide vertical positioning and the Horizontal POSITION control will provide horizontal positioning.

3. Advance the INTENSITY control until the display is visible. If the display is not visible with the INTENSITY control at midrange, press the BEAM FIND pushbutton and adjust the CH 1 and CH 2 VOLTS/DIV switches until the display is reduced in size both vertically and horizontally. Then, center the compressed display with the vertical POSITION controls, and release the BEAM FIND pushbutton. Adjust the FOCUS control for a well-defined display.

CIRCUIT DESCRIPTION

Introduction

This section of the manual contains a description of the circuitry used in the 465 Oscilloscope. The description begins with a discussion of the instrument, using the basic block diagram shown in Fig. 3-1. Then, each circuit is described in detail using detailed block diagrams to show the interconnections between the stages in each major circuit and the relationship of the front panel controls to the individual stages.

A complete block diagram is located in the Diagrams Section at the back of this manual. This block diagram shows the overall relationship between all of the circuits. Complete schematics of each circuit are also given in the Diagrams Section. Refer to these diagrams throughout the following circuit description for electrical values and relationships.

Digital Logic

Digital logic techniques are used to perform many functions within this instrument. The function and operation of the logic circuits are described using logic symbology and terminology. All logic functions are described using the positive logic convention. Positive logic is a system of notation where the more positive of two levels (HI) is called the true or 1 state; the more negative level (LO) is called the false or 0 state. The HI-LO method of notation is used in this logic description. The specific voltages which constitute a HI or LO state vary between individual devices. Typical HI and LO logic levels are shown on the diagrams at the rear of this manual.

It should be noted that not all of the integrated circuit devices in this instrument are digital logic devices. The function of non-digital devices will be described individually using operating waveforms or other techniques to illustrate their function.

BLOCK DIAGRAM

General

The following discussion is provided to aid in understanding the overall concept of the 465 Oscilloscope before

the individual circuits are discussed in detail. A basic block diagram of the 465 Oscilloscope is shown in Fig. 3-1. Only the basic interconnections between the individual blocks are shown on this diagram. Each block represents a major circuit within the instrument. The number on each block refers to the complete circuit diagram which is located at the rear of this manual.

Signals to be displayed on the CRT are applied to the CH 1 OR X and/or CH 2 OR Y connectors. The input signals are then amplified by the Preamp circuits. Each Preamp circuit includes separate vertical deflection factor, input coupling, balance, gain, and variable attenuation controls. A trigger pickoff stage in each Vertical Preamp circuit supplies a sample of the channel signals to the Trigger Generator circuit. A sample of the Channel 1 signal is also supplied to the CH 1 VERT SIGNAL OUT BNC connector on the instrument rear panel. In the X-Y mode of operation the Channel 1 signal is connected to the input of the Horizontal Amplifier circuit to provide the X-Axis deflection. The Channel 2 Vertical Preamp circuit contains an invert feature to invert the Channel 2 signal as displayed on the CRT. The output of both Vertical Preamp circuits is connected to the Vertical Switching circuit. This circuit selects the channel(s) to be displayed. An output signal from this circuit is connected to the Z Axis Amplifier circuit to blank out the switching transients between channels when in the chopped mode of operation. A trigger pickoff stage at the output of the Vertical Switching circuit provides a sample of the displayed signal(s) to the Trigger Generator circuit.

The output of the Vertical Switching circuit is connected to the Vertical Output Amplifier through the Delay Line. The Vertical Output Amplifier circuit provides the final amplification for the signal before it is connected to the vertical deflection plates of the CRT. This circuit includes the BEAM FIND switch which compresses the vertical and horizontal deflection to within the viewing area to aid in locating an off-screen display.

The A and B Trigger Generator circuits produce an output pulse which initiates the sweep signal produced by the A or B Sweep Generator circuits. The input signal to the A and B Trigger Generator circuits can be individually selected from the Channel 1 signal, Channel 2 signal, the signal(s) displayed on the CRT, a signal connected to the external trigger input connectors, or a sample of the line

Circuit Description—465

voltage applied to the instrument. Each trigger circuit contains level, slope, coupling, and source controls.

The A Sweep Generator circuit, when initiated by the A Trigger Generator circuit, produces a linear sawtooth output signal, the slope of which is controlled by the A TIME/DIV switch. The TRIG MODE switch controls the operating mode of the A Sweep Generator circuit. In the AUTO position, the absence of an adequate trigger signal causes the sweep to free run. In the NORM position, a horizontal sweep is presented only when correctly triggered by an adequate trigger signal. Pushing the SING SWP pushbutton allows one (and only one) sweep to be initiated. The Z Axis Logic circuit produces an unblanking gate signal to unblank the CRT so that the display can be presented. This gate signal is coincident with the sawtooth produced by the A Sweep Generator circuit. A gate signal, which is also coincident with the sawtooth, is available at the A + GATE connector on the instrument rear panel. The Z Axis Logic circuit also produces an alternate sync pulse which is connected to the Vertical Switching circuit. This pulse switches the display between channels at the end of each sweep when the VERT MODE switch is in the ALT position.

The B Sweep Generator circuit is basically the same as the A Sweep Generator circuit. However, this circuit only produces a sawtooth output signal after a delay time determined by the A TIME/DIV switch and the DELAY TIME POSITION dial. If the B Triggering SOURCE switch is set to the STARTS AFTER DELAY position, the B Sweep Generator begins to produce the sweep immediately following the selected delay time. If this switch is in one of the remaining positions, the B Sweep Generator circuit does not produce a sweep until it receives a trigger pulse occurring after the selected delay time.

The output of either the A or B Sweep Generator is amplified by the Horizontal Amplifier circuit to produce horizontal deflection for the CRT except in the fully counterclockwise (X-Y) position of the TIME/DIV switch. This circuit contains a 10X magnifier to increase the sweep rate 10 times in any A or B TIME/DIV switch position. Other horizontal deflection signals can be connected to the horizontal amplifier by using the X-Y mode of operation. When the TIME/DIV switch is set to X-Y, the X signal is connected to the Horizontal Amplifier circuit through the Channel 1 Vertical Preamp circuit.

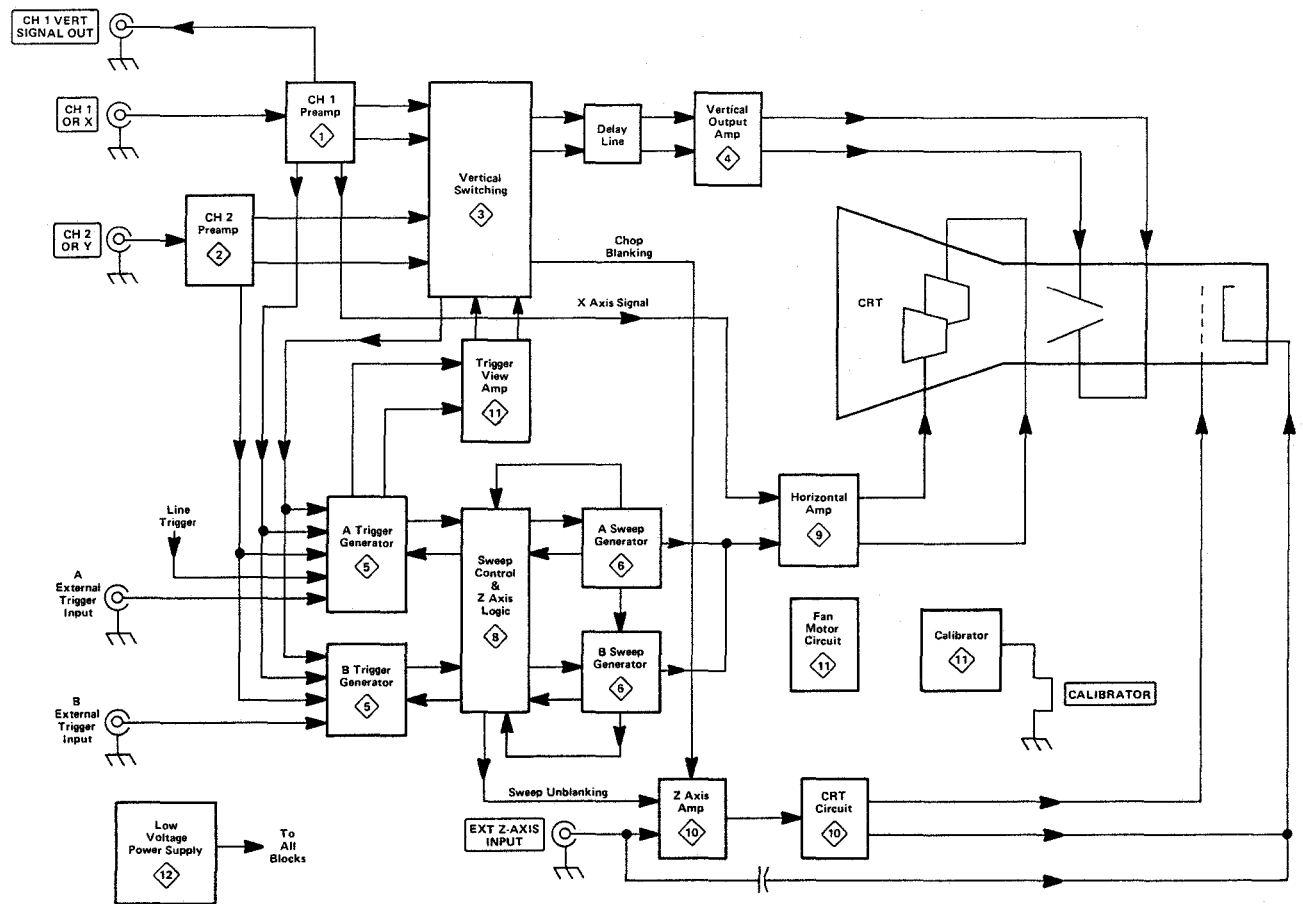

Fig. 3-1. Basic block diagram of the 465.

CHANNEL 1 PREAMP

The Z Axis Amplifier circuit determines the CRT intensity and blanking. The Z Axis Amplifier circuit sums the current inputs from the INTENSITY control, Vertical Switching circuit (chopped blanking), Z Axis Logic circuit (unblanking), and the external Z AXIS INPUT connector. The output level of the Z Axis Amplifier circuit controls the trace intensity through the CRT Circuit. The CRT circuit provides the voltages and contains the controls necessary for operation of the cathode-ray tube.

The Power Supply circuit provides the low voltage power necessary for operation of this instrument. This voltage is distributed to all of the circuits in the instrument as shown by the Power Distribution Diagram. The Calibrator circuit produces a square-wave output with accurate voltage and current amplitudes which can be used to check the calibration of the instrument and the compensation of probes. The CALIBRATOR current loop provides an accurate current source for calibration of current measuring probe systems.

General

Input signals for vertical deflection on the CRT can be connected to the CH 1 OR X input connector. In the X-Y mode of operation the input signal connected to the CH 1 OR X connector provides the horizontal (X axis) deflection (TIME/DIV switch set to X-Y, VERT MODE switch set to CH 2 OR X-Y). The Channel 1 Preamp circuit provides control of input coupling, vertical deflection factor, gain, and DC balance. Fig. 3-2 shows a detailed block diagram of the Channel 1 Preamp circuit. A schematic of this circuit is shown on Diagram 1 at the rear of the manual.

Input Coupling

Signals applied to the input connector can be AC coupled, DC coupled, or internally disconnected from the input to the Vertical Input Amplifier circuits. When the Input Coupling switch S5 is set for DC coupling, the input signal is coupled directly to the Input Attenuator stage. When AC coupled, the input signal passes through capacitor C3. This capacitor prevents the DC component of the signal

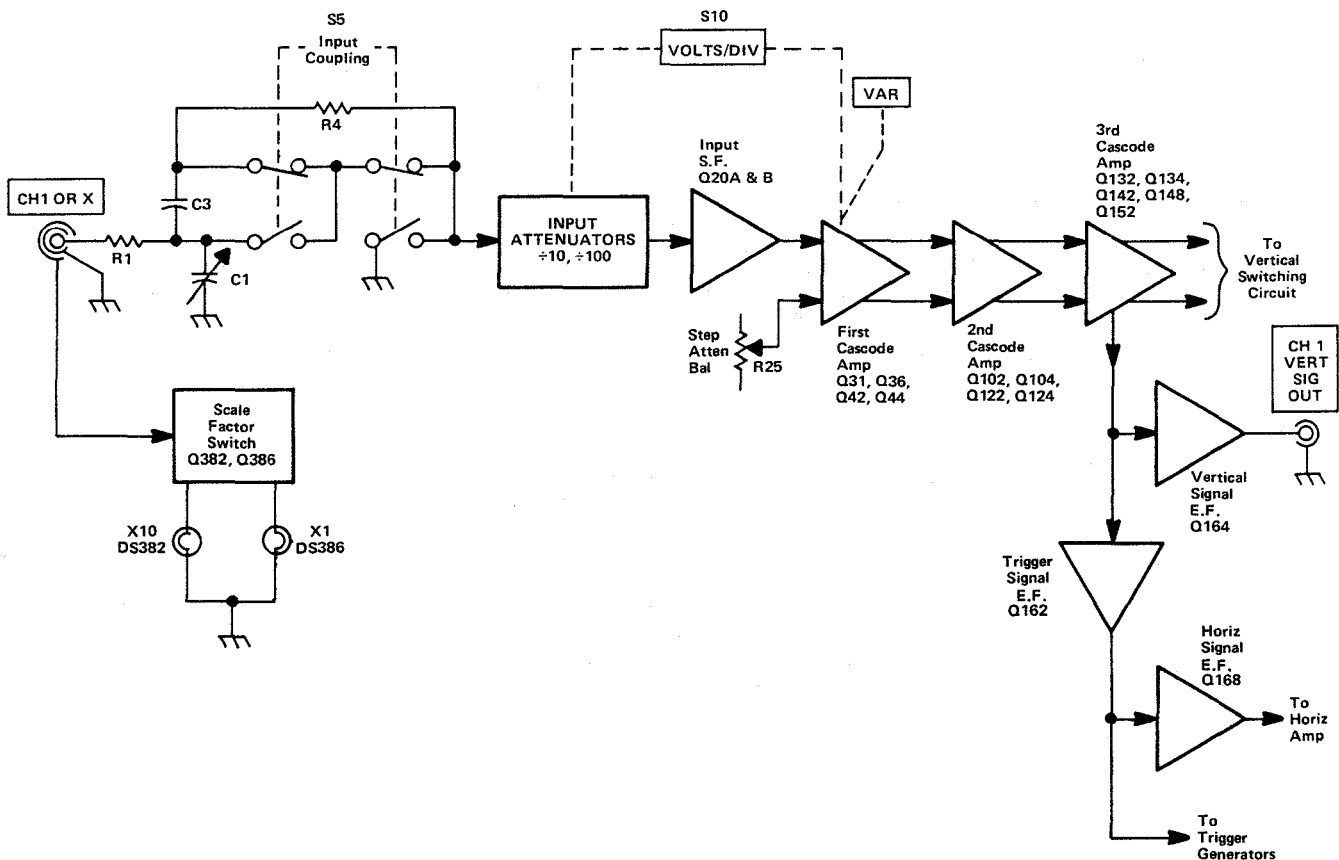

Fig. 3-2. Detailed block diagram of the Channel 1 Preamplifier.

Circuit Description—465

from passing to the amplifier. In the GND position, S5 opens the signal path and connects the input of the amplifier to ground. This provides a ground reference without the need to disconnect the applied signal from the input connector. Resistor R4, connected across the input coupling switch, allows C3 to be pre-charged in the ground position so that the trace remains on screen when switched to the AC position.

Input Attenuator

The effective overall deflection factor of each channel of the 465 is determined by the appropriate VOLT/DIV switch. The basic deflection factor of the Vertical Deflection System is 5 mV/division of CRT deflection. To achieve the deflection factor values indicated on the front panel, precision attenuators are switched in to the circuit and the gain of the First Cascode Amplifier stage is changed.

For the VOLT/DIV switch positions above 5 mV, attenuators are switched in to the circuit, singly or in pairs, to help produce the vertical deflection factors indicated on the front panel. These attenuators are frequency-compensated voltage dividers. In addition to providing constant attenuation at all frequencies within the bandwidth of the instrument, the Input Attenuators are designed to maintain the same input RC characteristics (1 M Ω times approximately 20 pF) for each setting of the VOLT/DIV switch. Each attenuator contains an adjustable series capacitor to provide correct attenuation at high frequencies and an adjustable shunt capacitor to provide correct input capacitance.

NOTE

Each attenuator is a hybrid encapsulated plug-in assembly; therefore, replacement of individual components within the attenuator is not possible. Should defects occur, the attenuator must be replaced as a unit.

Scale-Factor Switching Circuit

The vertical deflection factor for each channel is indicated by back-lighting the appropriate figures imprinted on the flange of the VOLTS/DIV knob. When a X1 probe is connected to the CH 1 OR X input connector, the base level of transistor Q386 is determined by the voltage divider composed of R384, R383 and X10 display factor bulb DS382. Q386 is biased into saturation and conducts current through the X1 indicator DS386. When Q386 conducts, the voltage level at its collector is very close to +5 volts. Therefore, there is insufficient bias at the base of Q382 to cause Q382 to conduct, and the X10 indicator DS382 remains dark.

When a X10 probe with a scale factor switching connector is attached to the CH 1 OR X input connector, the base of Q382 is returned to ground through R381. Q382 is now biased into saturation and conducts current through X10 indicator DS382. The collector level of Q382 is very close to +5 volts; therefore, there is insufficient bias at the base of Q386 to cause it to conduct and X1 indicator DS386 remains dark.

Source Follower Stage

The Channel 1 signal from the Input Attenuator is connected to the Source Follower Stage through R16 and C16. R15 provides the input resistance for this stage. R16 limits the current drive to the gate of Q20A. Diode CR18 protects the circuit by clamping the gate of Q20A at about -8.7 volts if a high amplitude negative-going signal is applied to the CH 1 OR X input connector. Q20B is a relatively constant current source for Q20A.

First Cascode Amplifier Stage

The Paraphase Amplifier Stage composed of Q32 and Q36 converts the single-ended input signal into a push-pull output signal. C33, C34 and CR34 optimize high frequency response through the amplifier stage. R37 and R38 provide thermal balance for the amplifier. C37 and C38 minimize Miller effect through Q32 and Q36. Step Atten Bal adjustment R25 adjusts for no baseline shift of a CRT display when switching between adjacent positions of the VOLTS/DIV switch.

The Common Base Amplifier stage composed of Q42 & Q44 converts the input signal currents into output voltage signals across load resistors R44 and R45. Correct vertical deflection factors are obtained by using a combination of attenuation in the Input Attenuator Stage and changing the gain of the first Cascode Amplifier Stage. For example, when switching from 50 mV/division to 100 mV/division, the input attenuator remains the same but R46 is switched in parallel with R44 and R45. This divides the output load resistance of the Common Base Amplifier Stage by two, thereby reducing the gain of the stage by two. C46, C47, C48, C49, R47 and R48 provide optimum high frequency response through the channel amplifier when operating with reduced gain.

Second Cascode Amplifier

Transistors Q102-Q122 and Q104-Q124 constitute the Second Cascode Amplifier stage of the Channel 1 vertical preamplifier. Gain adjust R118 sets the overall gain of the Channel 1 vertical preamplifier by adjusting the signal current into the emitters of Q122 and Q124. The VAR control R112, when rotated out of the calibrated detent

CHANNEL 2 PREAMP

position, also adjusts the signal currents into Q122 and Q124 to provide uncalibrated deflection factors between the calibrated settings of the VOLTS/DIV switch. Variable balance adjustment R120 adjusts for no baseline shift of a CRT display when rotating the VAR control. Position Centering adjustment R115 centers the range of control of the Channel 1 POSITION control.

General

The Channel 2 Preamp circuit is basically the same as the Channel 1 Preamp. Only the specific differences between the two circuits are described here. Portions of this circuit not described in the following description operate in the same manner as for the Channel 1 Preamp. Fig. 3-3 shows a detailed block diagram of the Channel 2 Preamp circuit. A schematic of this circuit is shown on diagram 2 at the rear of this manual.

Third Cascode Amplifier

Q132 and Q134, in conjunction with Q304 and Q308 in the Vertical Switching Circuit, form the Third Cascode Amplifier stage. Thermistor RT131 (between the emitters of Q132 and Q134) changes in value with changes in temperature. This varies the gain of the Third Cascode Amplifier stage to compensate for changes in total amplifier gain that occur with variations in operating temperature. The push-pull signals picked off in the emitters of Q132 and Q134 are converted to a single-ended signal by Q142 and Q148. This signal is amplified by common-base amplifier stage Q152 and applied to the bases of emitter followers Q162 and Q164. Q164 provides the output signal to the CH 1 VERT SIGNAL OUT connector located on the instrument rear panel. The output signal at the emitter of Q162 is used as the trigger signal source in the CH 1 positions of the Trigger SOURCE switches and as the signal source for emitter follower Q168. Q168 provides the X-axis signal from the Channel 1 Preamplifier to the Horizontal Amplifier in the X-Y mode of operation. CR164, CR165, CR166, and CR167 protect the emitter circuit of Q164 in the event large voltage levels are accidentally connected to the CH 1 VERT SIGNAL OUT connector. R155 adjusts the DC level of the CH 1 trigger source signal.

Second Cascode Amplifier

The Second Cascode Amplifier in Channel 2 is basically the same as the Second Cascode Amplifier in Channel 1 except that the Channel 2 INVERT switching takes place here. For a normal (non-inverted) display, +5 volts is connected to the bases of transistors Q222 and Q224 by INVERT switch S225. The voltage divider comprised of R225 and R226 applies approximately +2.5 volts to the base of Q226 and Q228. Q222 and Q224 are biased on and Q226 and Q228 are biased off, and the signal passes on to the output cascode amplifier stage normally. With the INVERT switch in the INVERT (button in) position, +5 volts is applied to the bases of Q226 and Q228. The voltage divider composed of R225 and R224 applies approximately +2.5 volts to the bases of Q222 and Q224. Q226 and Q228 are now biased on and Q222 and Q224 are biased off. The signal that was normally applied to the base of Q232 is now applied to the base of Q234 through transistor Q228 and the signal that was normally applied to the base of Q234 is now applied to the base of Q232 through transistor Q226.

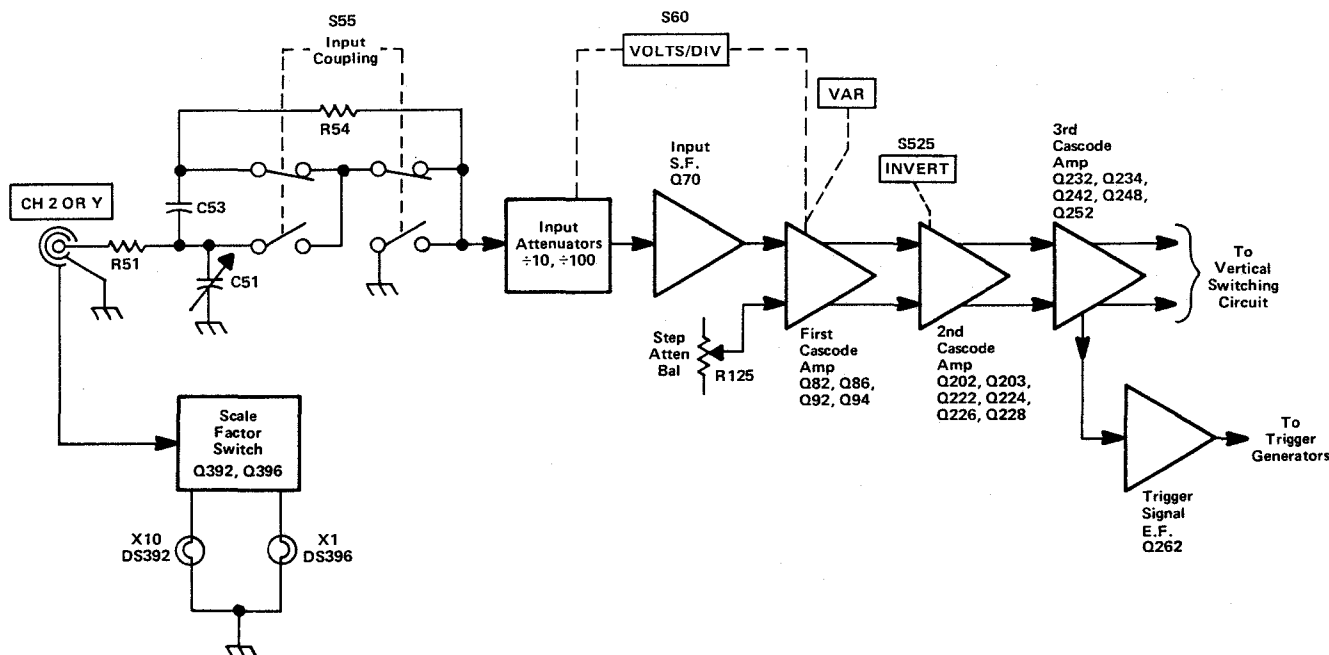

Fig. 3-3. Detailed block diagram of the Channel 2 Preamp.

Third Cascode Amplifier

The trigger pickoff circuit only provides a signal to one emitter follower. This emitter follower (Q262) in turn provides the trigger signal to the Trigger Generator circuits in the CH 2 positions of the SOURCE switches.

Preamp output signals to be coupled to the Vertical Output Amplifier. CR304, CR305, CR307 and CR308 control the Channel 1 output and CR314, CR315, CR317 and CR318 control the Channel 2 output. These diodes are in turn controlled by the Switching Multivibrator for dual trace displays, or by the VERT MODE switch for single trace displays.

VERTICAL SWITCHING CIRCUIT

General

The Vertical Switching Circuit determines whether the Channel 1 or Channel 2 or both signals are connected to the Vertical Output Amplifier Circuit. In the alternate and chopped modes of operation both channels are alternately displayed on a shared time basis. Fig. 3-4 shows a detailed block diagram of the Vertical Switching Circuit. A schematic of this circuit is shown on diagram 3 at the rear of this manual.

Diode Gates

The Diode Gates, consisting of four diodes each, can be thought of as switches which allow either of the Vertical

Channel 1 Only Display. When the CH 1 pushbutton is pressed, -8 volts is applied to the junction of CR315-CR317 in the Channel 2 Diode Gate through R367 (see simplified diagram in Fig. 3-5). This forward biases CR315 and CR317 and reverse biases CR314 and CR318. CR314 and CR318 block the Channel 2 signal so it cannot pass to the Delay Line Driver stage. At the same time in the Channel 1 Diode Gate, CR305 and CR307 are connected to $+5$ volts through R371. CR305 and CR307 are held reverse-biased while CR304 and CR308 are forward biased. Therefore, the Channel 1 signal passes to the Delay Line Driver stage.

Channel 2 Display Only. When the CH 2 pushbutton is pressed, the above conditions are reversed. The junction of CR305-CR307 is connected to -8 volts through R376 and

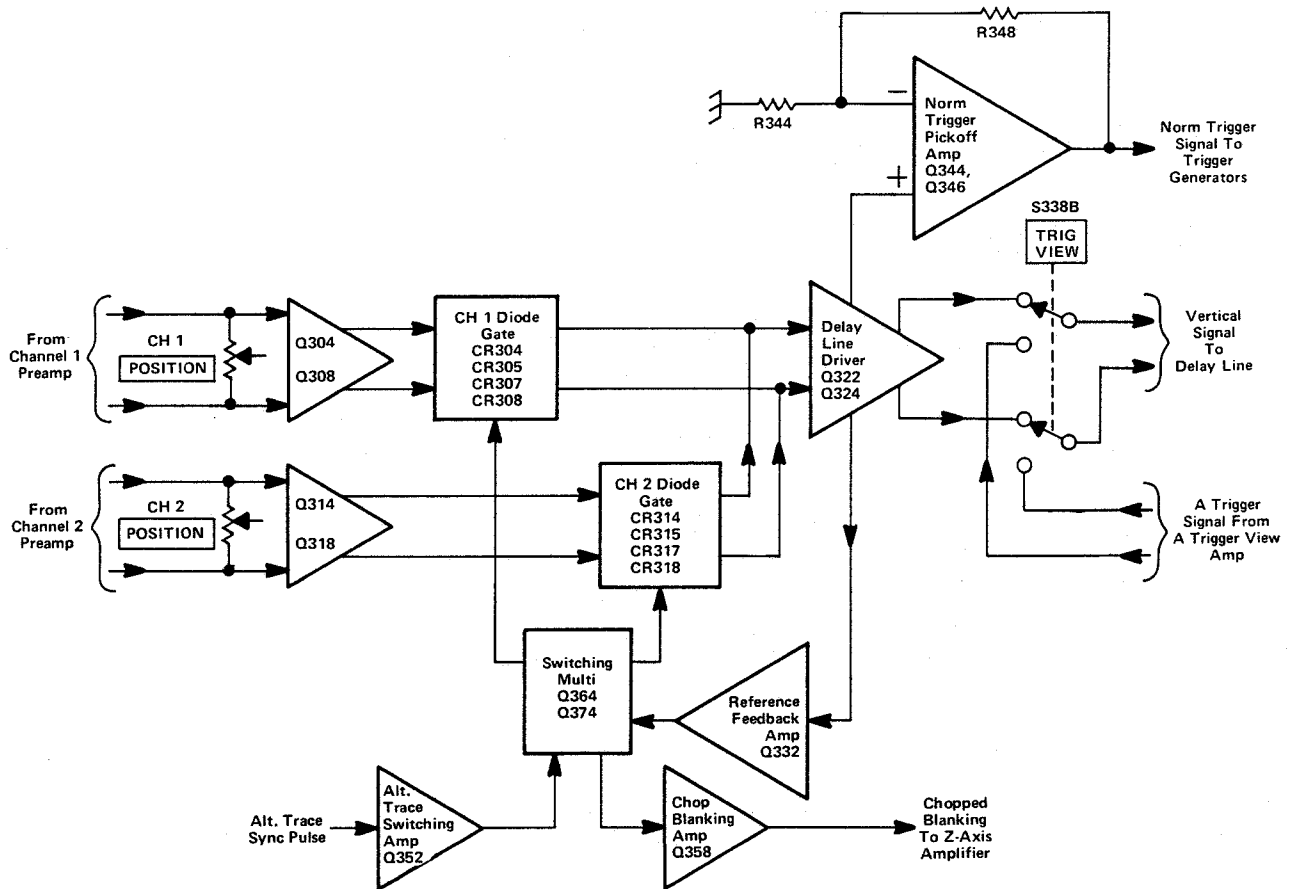

Fig. 3-4. Detailed block diagram of the Vertical Switching Circuit.

the junction of CR315-CR317 is connected to +5 volts through R361. The Channel 1 Diode Gate blocks the Channel 1 signal and the Channel 2 Diode Gate allows the Channel 2 signal to pass to the Delay Line Driver stage.

Switching Multivibrator

Alternate Trace Display. In this mode of operation, the Switching Multivibrator operates as a bistable multivibrator. When the ALT pushbutton is pressed, -8 volts is applied to the emitter of Alternate Trace Switching Amplifier stage Q352 by the VERT MODE switch. Q352 is forward biased to supply current to the "on" Switching-Multivibrator transistor through R352 and CR368 or CR378. For example, if Q374 is conducting, current is supplied to Q374 through R352 and CR378. The current flow through collector resistor R371 drops the CR305-CR307 cathode level negative so that the Channel 1 Diode Gate is blocked as for Channel 2 Only Operation. The signal passes through the Channel 2 Diode Gate to the Delay-Line Driver stage.

The alternate trace sync pulse is applied to the base of Q352 through C351 at the end of each sweep. This

negative-going sync pulse momentarily interrupts the current through Q352 and both Q364 and Q374 are turned off. When Q352 turns on again after the alternate trace sync pulse, the charge on C368 determines whether Q364 or Q374 conducts. For example, when Q374 was conducting, C368 was charged positive on the CR378 side to the emitter level of Q374 and negatively on the CR368 side toward the negative level at the junction of CR368 and CR378. This charge is stored while Q352 is off and holds the emitter of Q364 more negative than the emitter of Q374. During the time Q364 and Q374 are turned off, the voltages at their bases become approximately equal. Now, when Q352 comes back on, the transistor with the most negative emitter conducts first, the resulting negative movement at its collector holds the other transistor off. The conditions described previously are now reversed: now, the Channel 2 Diode Gate is reverse-biased and the Channel 1 signal passes through the Channel 1 Diode Gate.

Chopped Mode Operation. When the CHOP pushbutton is pressed, the Switching Multivibrator stage free-runs at about a 250 kHz rate. The emitters of Q364 and Q374 are connected to -8 volts through R368, R378, and the primary of transformer T354. At the time of turn-on, one

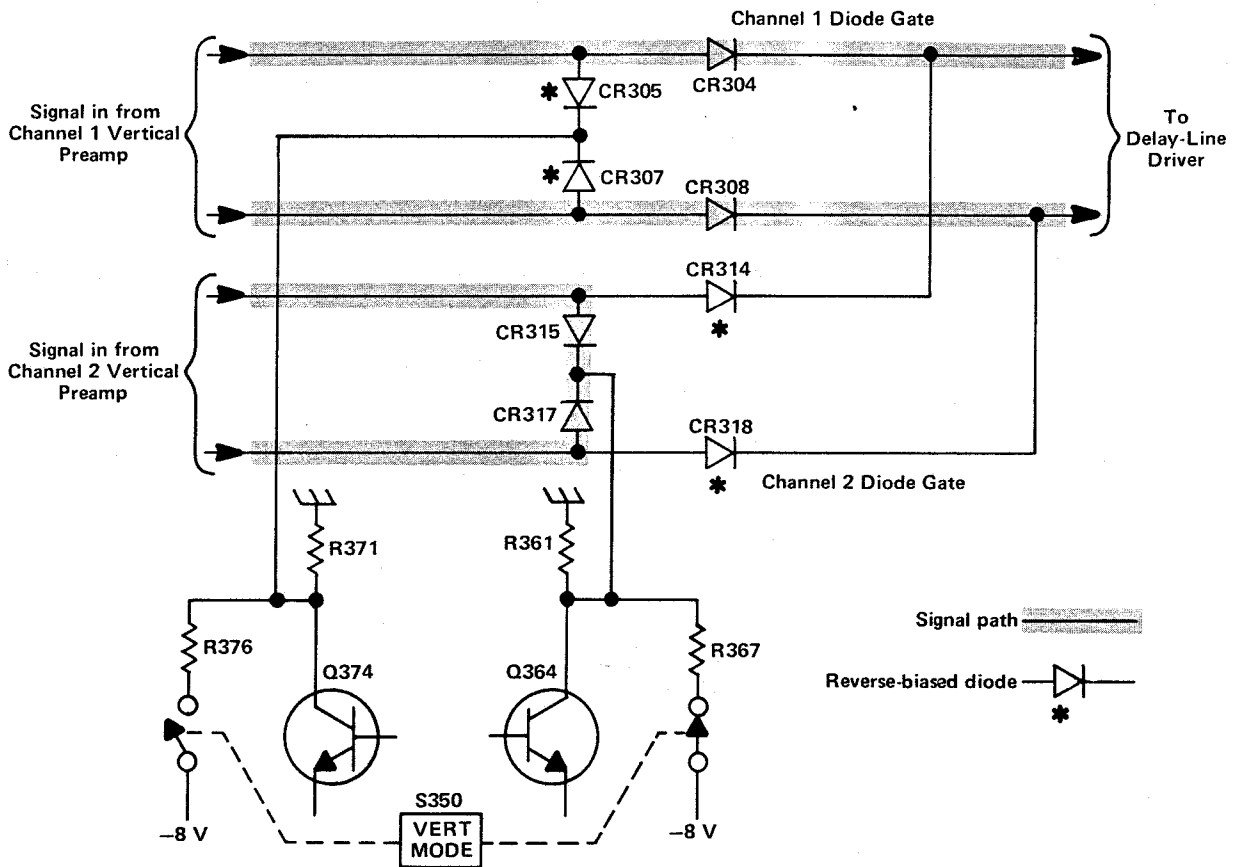

Fig. 3-5. Effect of Diode Gates on signal path (simplified Vertical Switching diagram). Conditions shown for CH 1 position of VERT MODE switch.

of the transistors begins to conduct; for example, Q374. The negative level at the collector of Q374 forward-biases CR305 and CR307 and back-biases CR304 and CR308 preventing the Channel 1 signal from reaching the Delay-Line Driver stage. Meanwhile, the Channel 2 Diode Gate passes the Channel 2 signal to the Delay-Line Driver stage.

The frequency-determining components in the CHOP mode are C368, R368, R370, and R378. The switching action occurs as follows: when Q374 is on, C368 attempts to charge to -8 volts through R368. The emitter of Q364 slowly goes toward -8 volts as C368 charges. The base of Q364 is held at a point determined by the voltage divider R365 and R374 between -8 volts and the collector level of Q374. When the emitter voltage of Q364 reaches a level slightly more negative than its base, Q364 conducts. Its collector level goes negative and pulls the base of Q374 negative through divider R364-R375 to cut Q374 off. This switches the Diode Gate stages to connect the opposite channel to the Delay-Line Driver stage. Again, C368 begins to charge towards -8 volts but this time through R378. The emitter of Q374 slowly goes negative as C368 charges until Q374 turns on. Q364 is shut off and the cycle begins again.

The Chop Blanking Amplifier stage, Q358, provides an output pulse to the Z Axis Amplifier circuit which blanks out the transition between the Channel 1 and the Channel 2 traces. When the Switching Multivibrator stage changes states, the voltage across T354 momentarily increases. A negative pulse is applied to the base of Q358 to turn it off. The width of the pulse at the base of Q358 is determined by R356 and C356. Q358 is quickly driven in to cutoff and the positive going output pulse, which is coincident with trace switching, is connected to the Z Axis Amplifier circuit through R359.

Added Mode Operation. When the ADD pushbutton is pressed, the following occurs:

1. +5 volts is applied to the cathodes of CR305 and CR307 through R371.
2. +5 volts is applied to the cathodes of CR315 and CR317 through R361.
3. -8 volts is applied to the junction of R321 and R322.

The first two actions enable both of the Channel Diode Gates so that the signal applied to the Delay Line Driver stage is the algebraic sum of the Channel 1 and Channel 2 signals. The -8 volts applied to R321 and R322 provides sufficient current to keep both diode gates turned on without altering the DC levels associated with the Delay Line Driver stage.

Delay-Line Driver

The outputs from the Diode Gate stages are applied to the Delay-Line Driver stage composed of Q322 and Q324.

Q322 and Q324 are connected as feedback amplifiers with R325 and R327 providing feedback from the collector to the base of their respective transistors. A sample of the signal in the collector circuit of Q322 is used for triggering in the NORM mode of trigger operation. The BW LIMIT switch S338A connects a pi filter composed of C338, C339, L338, and L339 between the output signal lines of the Delay-Line Driver stage to reduce the upper -3 dB bandwidth limit of the Vertical Amplifier system to approximately 20 MHz. R335 and R336 provide reverse termination for the delay line. The TRIG VIEW switch S338B connects the output of the Trigger View Amplifier to the input of the Delay Line in place of the Delay Driver Stage. This allows viewing the trigger signal present in the A Trigger Generator Circuit.

Reference Feedback Amplifier

Reference Feedback stage Q332 provides common mode voltage feedback from the Delay-Line Driver stage to allow the diode gates to be switched with a minimum amplitude switching signal. The emitter level of Q332 is connected to the junction of the Switching Multivibrator collector resistors, R371 and R361 through CR372 or CR362. The collector level of the "on" Switching Multivibrator transistor is negative and either CR362 or CR372 is forward biased. This clamps the cathode level of the forward biased shunt diodes in the applicable Diode Gate about 0.5 volt more negative than the emitter level of Q332. The level at the emitter of Q332 follows the average voltage level at the emitters of the Delay-Line Driver stage. The shunt diodes are clamped near their switching level and therefore, can be switched very fast with a minimum amplitude switching signal. This maintains about the same current through the Diode Gate shunt diodes so they can be switched with a minimum amplitude switching signal regardless of the deflection signal at the anodes of the shunt diodes.

Normal Trigger Pickoff Amplifier

The trigger signal for NORM trigger operation is obtained from the collector of Q322. Normal Trigger DC Adjustment R340 sets the DC level of the normal trigger output signal so the sweep is triggered at the 0 level of the displayed signal when the Triggering LEVEL control is set to 0. Q344 and Q346 are connected as a feedback amplifier with the signal applied to the non-inverting input and the feedback connected between the output and the inverting input. Gain of the stage is approximately:

$$\frac{R348 + R344}{R344}$$

VERTICAL OUTPUT AMPLIFIER

General

The Vertical Output Amplifier circuit provides the final amplification for the vertical deflection signal. This circuit includes the Delay Line and the BEAM FIND pushbutton. The BEAM FIND pushbutton compresses an overscan

display to within the viewing area when pressed. A schematic of the Vertical Output Amplifier circuit is shown on diagram 4 at the rear of this manual.

Delay Line

Delay Line DL400 provides approximately 120 ns delay for the vertical signal to allow the Sweep Generator circuits time to initiate a sweep before the vertical signal reaches the vertical deflection plates of the CRT. This allows the instrument to display the leading edge of the signal originating the trigger pulse when using internal triggering.

Output Amplifier

U440 is an integrated circuit amplifier stage that provides the final amplification for the vertical signal. R401 and R411 provide forward termination for the delay line. The components connected between pins 2 and 4 of U440 provide delay-line compensation. Components connected between pins 14 and 15 and pins 7 and 8 of U440 provide thermal compensation for the stage. The BEAM FIND switch, when pressed, reduces the dynamic swing capabilities of the stage, thereby limiting the display to within the display area of the CRT.

A AND B TRIGGER GENERATORS

General

The Trigger Generator circuits produce trigger pulses to start the Sweep Generator circuits. These trigger pulses are derived either from the internal trigger signal from the vertical deflection system, an external signal connected to the external trigger input connectors, or a sample of the line voltage applied to the instrument. Controls are provided in each circuit to select trigger level, slope, coupling, and source. Since the A and B Trigger Generator circuits are virtually the same, only the A Trigger Generator circuit action and the differences between the A and B Trigger Generator circuits are explained. A schematic of these circuits is shown on diagram 5 at the back of this manual.

Trigger Source

The Trigger SOURCE switch S610 selects the source of the trigger signal. The sources available to the A Trigger Generator circuit are the signal(s) being displayed (NORM), Channel 1 (CH 1), Channel 2 (CH 2), LINE, and EXT. The EXT \div 10 (A trigger circuit only) position provides 10 times attenuation for the external trigger signal. The B Trigger SOURCE switch does not have a LINE or an EXT \div 10 position, but has a STARTS AFTER DELAY position.

In the LINE mode of triggering, a sample of the power line frequency is obtained from the secondary of power transformer T1501 in the Low Voltage Power Supply circuit. To prevent unwanted attenuation of the trigger signal by the LF REJ circuit, the Trigger COUPLING switches should not be in the LF REJ mode when using line voltage as a trigger source.

Trigger Coupling

The Trigger COUPLING switches offer a means of accepting or rejecting certain components of the trigger signal. In the AC, LF REJ, and HF REJ mode of trigger coupling, the DC component of the trigger signal is blocked by coupling capacitors C612 or C611. Frequency components below about 60 Hz are attenuated when using AC or HF REJ coupling and below about 15 kHz when using LF REJ coupling. The higher frequency components of the trigger signal are passed without attenuation. In the HF REJ mode of trigger coupling, the high frequency components of the trigger signal (above about 50 kHz) are attenuated, while the lower frequency components are passed without attenuation. The DC mode of trigger coupling passes unattenuated all signals from DC to 100 MHz and above.

Input Source Follower

Transistor Q622 is an FET source follower. It provides a high input impedance (set primarily by R616) for the trigger signal and also provides isolation between the Trigger Generator circuit and the trigger signal source. Diode CR617 provides input protection for Q622 if excessively high amplitude negative-going input signals are present. Q624 is a high-impedance, relatively constant, current source for Q622, and provides a measure of temperature compensation for Q622.

Paraphase Amplifier

U640 is a paraphase amplifier stage that converts the single-ended input from Source Follower Q622 into a push-pull output applied to the tunnel diode driver stage. Trigger Level Centering adjustment R635 sets the level at pins 14 and 15 of U640 so that the display is correctly triggered when the LEVEL control is centered. The LEVEL control varies the level at pins 14 and 15 of U640 to select the point on a trigger signal where triggering occurs.

The slope of the input signal that triggers the Sweep Generator circuit is determined by the setting of the SLOPE switch S630. When the SLOPE switch is set to the + position, the output signal present at pin 8 of U640 is in phase with the input signal and the output signal at pin 9 is

inverted with respect to the input signal. When the SLOPE switch is set to the — position, the output signal at pin 8 is inverted with respect to the input signal and the output signal at pin 9 is in phase with the input signal.

thereby resetting both CR650 and CR652 to their low voltage states. The reset level remains during holdoff time to ensure that a sweep gating signal will not be generated until the sweep circuit has returned to its quiescent state.

Tunnel Diode Driver

Q650 and Q652 are common-emitter amplifier stages that provide the signal currents necessary to switch the triggering tunnel diodes. CR650 and CR652 are 4.7 mA tunnel diodes. Quiescently (i.e., after the sweep holdoff period has passed, but before triggering), CR650 and CR652 are biased into their low voltage states. Q650 cannot provide sufficient current to switch CR650 to its high voltage state. Q652, however, can provide sufficient current to bias CR652 into its high voltage state; when Q652 next conducts triggering signal current, the anode of CR652 steps positive to an approximate +0.5 volt level. Since only approximately 1 mA of current is required to maintain CR652 in its high voltage state, this makes approximately 3 mA of current additionally available with which to switch CR650 to its high voltage state. Thus, the next time Q650 conducts signal current, CR650 steps to its high voltage state, sending a positive pulse to the logic circuit to initiate sweep action. A Trigger Sensitivity adjustment R655 adjusts the tunnel diode bias to the proper level that will not allow CR650 to be switched to its high voltage state until CR652 has been switched to its high voltage state. At the end of the sweep time and during holdoff, a negative level is applied to the anode of CR652,

A AND B SWEEP GENERATORS

General

The A and B Sweep Generators produce sawtooth voltages which are amplified by the Horizontal Amplifier circuit to provide horizontal deflection on the CRT. These sawtooth voltages are produced on command (trigger pulses) from the Trigger Generator circuits. The Sweep Generator circuits also produce gate waveforms that are used by the Z Axis Logic circuit to unblank the CRT during sweep time, and by the Sweep Logic circuit to terminate sweep generation. Fig. 3-6 shows a detailed block diagram of the A Sweep Generator circuit. The B Sweep Generator circuit is very similar to the A Sweep Generator; therefore only the differences in operation associated with the B Sweep Generator will be discussed. A schematic of both circuits is shown on diagram 6 at the rear of this manual.

Disconnect Amplifier

After holdoff but before the next sweep, Disconnect Amplifier Q1024 conducts current through R1024 and the timing resistor R_t . This prevents timing current from

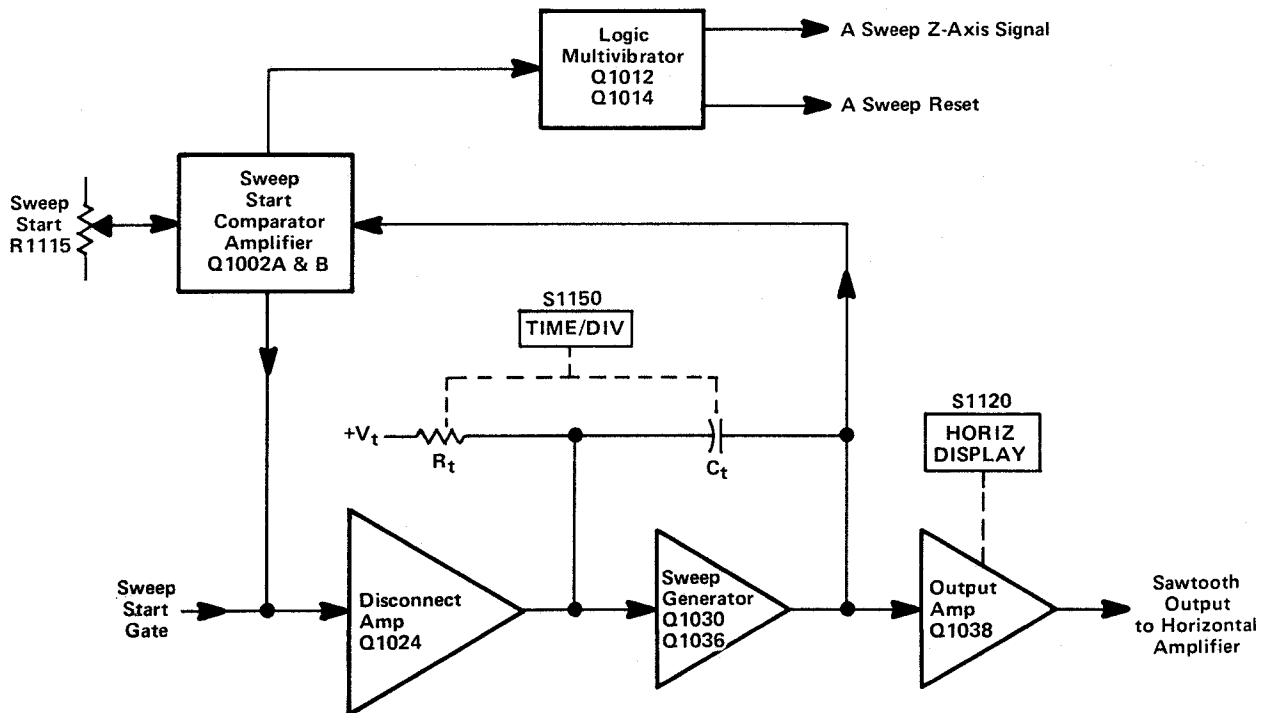

Fig. 3-6. Detailed block diagram of the A Sweep Generator.

charging the timing capacitance C_t . The positive-going sweep start gate from Q864 turns off Q1024 and the timing current now begins to charge the timing capacitance.

Sawtooth Sweep Generator

Q1030 and Q1036 compose a Miller Integrator circuit. When the current flow through the Disconnect Amplifier is interrupted, the timing capacitance begins to charge through the timing resistor. The timing resistor and capacitance are selected by the A TIME/DIV switch to provide the various sweep rates listed on the instrument front panel. The output signal at the collector of Q1036 is a negative-going sawtooth waveform.

Output Buffer Amplifier

The Output Buffer Amplifier stage is a common-base amplifier with the signal current-driven into the emitter. It provides the output sawtooth current signal to the Horizontal Amplifier and provides a measure of isolation between the Sawtooth Generator and the Horizontal Amplifier. The HORIZ DISPLAY switch connects to this stage to control the A sawtooth output in the various horizontal modes of operation. In the A and A INTEN modes of operation, the A sweep signal passes through Q1038 to the Horizontal Amplifier. However, in the MIX and B DLY'D modes, -8 volts is connected to zener diode VR1039 which sets the emitter of Q1038 at about -1.8 volts. This biases Q1038 off, preventing the A sawtooth signal from passing to the Horizontal Amplifier.

Sweep Start Amplifier

Just before the sweep starts to run down, the levels at the bases of Q1002 A and B are approximately equal. When the sweep starts to run down, the base of Q1002B goes negative, which increases the forward bias on CR1004. This in turn decreases the forward bias on CR1001, which, very shortly after the start of the sweep, becomes reverse biased to interrupt the current through Q1002A. The circuit remains in this condition until after the sweep retrace is complete. When the circuit returns to quiescence, Q1002A again begins to conduct through R1024. This sets the current through Q1024, which establishes the starting point for the sweep. The Sweep Start adjustment sets the base level of Q1002A. This level is also connected to the base of Q1062A in the B Sweep Generator except in the MIX mode of operation. This ensures that B Sweep starts at the same level as A Sweep.

Logic Multivibrator

Q1012 and Q1014 compose a multivibrator. At quiescence, Q1014 is conducting and Q1012 is turned off. When

the sweep starts to run, the negative-going ramp is coupled through the base of Q1002B and CR1004 to the cathode of CR1011. CR1011 becomes forward biased and when the level at the anode of CR1011 falls to about $+4$ volts Q1012 conducts and Q1014 turns off. The multivibrator remains in this state until the sweep starts to retrace and the voltage level at the anode of CR1011 rises above about $+4.5$ volts. The resultant pulse at the collector of Q1012 is applied to Sweep Control IC U870 to terminate the sweep. The pulse at the collector of Q1014 is applied to the A Sweep Z Axis Logic Gate to blank the CRT at the end of the sweep.

B Sweep Generator Differences

There are three prime differences between the A and B Sweep Generators. The B Sweep Output Buffer Amplifier is prevented from passing the B Sweep signal to the Horizontal Amplifier in the A and A INTEN positions of the HORIZ DISPLAY switch. There is a transistor stage connected as a constant current source in the emitter circuit of Q1062A and B (corrects for current imbalances side-to-side in Q1062 during MIX mode operation). The Sweep Start Level connected to the base of Q1062A is not always a fixed DC level. During MIX mode operation the A Sweep Sawtooth signal is applied to the base of the amplifier. Now, the DC level at which the B Sweep Generator will start generating its sawtooth waveform is constantly being changed by the A Sweep sawtooth. The output waveform from the B Sweep Generator takes the form of a composite sawtooth waveform, with the first and last parts occurring at a rate determined by the A Sweep Generator and the middle part occurring at a rate determined by the B Sweep Generator.

SWEEP AND Z AXIS LOGIC CIRCUIT

General

The Sweep And Z Axis Logic Circuit derives the logic levels necessary to control the sequence of events associated with sweep generation and CRT unblanking. The +A and +B GATE signals are also generated in this circuit. Positive logic terminologies and symbologies will be used in the following explanation of circuit operation. A schematic of this circuit is shown on diagram 8 at the rear of this manual.

A Sweep Gate

Q862 and Q864 compose the A Sweep Gate Circuit. They form an emitter coupled stage where only one transistor can be conducting at any time. The input signal to the stage is the positive-going trigger signal from the A Fire Trigger TD in the A Trigger Generator Circuit. The

Circuit Description—465

signal at the collector of Q862 is connected to the A Z Axis Gate Circuit to control CRT blanking and to generate the + A GATE signal. The signal at the collector of Q864 is connected to the emitter of the Sweep Disconnect Amplifier stage (Q1024) in the A Sweep Generator Circuit to initiate A Sweep generation.

B Sweep Gate

Q812 and Q814 compose the B Sweep Gate Circuit. They also form an emitter-coupled stage where only one transistor can be conducting at any time. The input signal to the stage is the positive-going trigger signal from the B Fire Trigger TD in the B Trigger Generator Circuit. The signal at the collector of Q812 is connected to the B Z Axis Gate Circuit to control CRT blanking and to generate the + B GATE signal. The signal at the collector of Q814 is connected to the emitter of the Sweep Disconnect Amplifier stage (Q1084) in the B Sweep Generator Circuit to initiate B Sweep generation.

Sweep Control Integrated Circuit

U870 is the Sweep Control Integrated Circuit. Several functions are performed in this stage, depending on the mode of operation of the instrument sweep generators. The following is a brief explanation of the function associated with each pin of the IC.

Pin 1. This is the positive Auto Sense input. The signal connected here comes from the A Fire Trigger TD.

Pin 2. This is the negative Auto Sense input. A fixed DC level established by R871 and R872 is connected here.

Pin 3. This is the + auto gate terminal. In the AUTO mode of operation, if no trigger signals are applied to pin 1 of U870 during the ≈ 100 ms following the end of holdoff the gate level at pin 3 steps LO to turn Q864 on which initiates a sweep.

Pin 4. Not used in this application.

Pin 5. Input terminal for negative voltage supply.

Pin 6. This is the auto gate timing terminal. R879 and C879 determine the amount of time between the end of holdoff and the generation of the auto gate.

Pin 7. This terminal lights the TRIG'D light when a triggered gate has occurred.

Pin 8. This is the holdoff timing terminal. The R/C connected to this terminal (selected by the TIME/DIV switch) determines the length of holdoff time.

Pin 9. Ground terminal.

Pin 10. This is the Holdoff output terminal. The gate level present here is LO during sweep holdoff time and HI otherwise.

Pin 11. This terminal lights the READY light when operating in the single sweep mode.

Pin 12. This is the single sweep mode terminal. When +5 volts is applied to this terminal the sweep operates in the single sweep mode; when the terminal is left open or grounded the sweep operates in the repetitive mode.

Pin 13. Not used in this application.

Pins 14 & 15. Single sweep reset terminals. Pushing the PUSH TO RESET button prepares the single sweep circuitry to respond to the next one triggering event. Also causes the READY light to be lit.

Pin 16. This is the holdoff start input terminal. The HI sweep reset gate pulse from the sweep generators is applied here to initiate sweep holdoff.

Pin 17. This is the sweep disable output terminal. The gate level at this terminal is HI during holdoff and LO otherwise.

Pin 18. Sweep lockout input. +5 volts applied to this terminal disables all sweep action.

Pin 19. Auto mode terminal. Grounding this terminal enables auto sweep operation.

Pin 20. Input terminal for positive voltage supply.

A Sweep Holdoff Amplifier

Q854 is the A Sweep Holdoff Amplifier. The holdoff gate waveform is applied to the base of Q854 through R858 and C858 from pin 17 of U870. When Q854 is turned off (during holdoff time), its collector is LO and CR851 is forward biased, which resets both the Arm and Fire trigger TD's in the A Trigger Generator. When Q854 is turned on (any time other than holdoff time), its collector level is HI and CR851 is reversed biased. This allows the trigger TD's in the A Trigger Generator to respond to the next adequate triggering signal.

B Sweep Holdoff Amplifier

Q804 is the B Sweep Holdoff Amplifier. Its circuit action is identical to that described for the A Sweep Holdoff Amplifier except that there are three gate signal sources that control the state of the stage. The three sources are the holdoff gate from pin 17 of U870 (through CR859), the collector of Q1052 in the Delay Pickoff Comparator, and the collector of Q822 in the B Latch Multivibrator (through CR809). All three gate sources must be in their LO state for B Sweep to be triggerable; any one of the sources in its HI state will disable the B Trigger Generator TD's.

A Sweep Z-Axis Gate

Q1304 and Q1306 comprise the A Sweep Z-Axis Gate. They form an emitter-coupled stage where only one transistor can be conducting at any time. The controlling signal inputs come from the collector of Q862 in the A Sweep Gate, the blanking signal from Q1014 in the A Sweep Generator, and Q824 in the B Latch Multivibrator (only in the MIX mode of operation). The blanking signal for use in the Z-Axis Amplifier is taken from the collector of Q1306 (through CR1342). The collector signal of Q1304 is applied to the +A GATE Emitter Follower.

In all positions of the HORIZ DISPLAY switch except for B DLY'D, -8 volts is connected to the cathode of CR1341. This pulls the anode of CR1306 down very close to -8 volts, causing CR1306 to be reverse biased, which in turn allows the gate signal at the collector of Q1306 to pass through CR1342. In the B DLY'D position of the HORIZ DISPLAY switch, -8 volts is no longer connected to CR1341. This allows CR1306 to be forward biased, which pulls up on the cathode of CR1342. This reverse-biases CR1342, which blocks the A blanking signal from reaching the Z-Axis Amplifier.

In all positions of the HORIZ DISPLAY switch except MIX, -8 volts is connected to the cathode of CR832. This keeps CR831 reverse biased and prevents the collector signal of Q824 from affecting the A Z-Axis Gate. However,

in the MIX position of the HORIZ DISPLAY switch, -8 volts is no longer connected to CR832. Now, when the B Sweep ends and sets the B Sweep Latch circuit, the collector signal of Q824 (through CR831) switches the A Sweep Z-Axis Gate causing the CRT display to be completely blanked. This prevents any further display of A Sweep in the MIX mode even though A Sweep may still be running.

B Sweep Z-Axis Gate

Q1324 and Q1326 compose the B Sweep Z-Axis Gate. They form an emitter-coupled stage where normally one transistor is on and the other is off. The controlling signal inputs come from the collector of Q812 in the B Sweep Gate and the blanking signal from Q1074 in the B Sweep Generator. The blanking signal for use in the Z-Axis Amplifier is taken from the collector of Q1326 (through CR1344). The collector signal of Q1324 is applied to the +B GATE Emitter Follower.

In the A position of the HORIZ DISPLAY switch, -8 volts is applied to the cathode of CR1347, which causes CR1345 to be back biased. The collector of Q1326 is pulled positive through R1326 and CR1326, which in turn back biases CR1344, preventing the B Sweep Z-Axis Gate from affecting CRT unblanking. In the MIX and A INTEN positions of the HORIZ DISPLAY switch, -8 volts is removed from the cathode of CR1347 and applied to the cathode of CR1327. This forward biases CR1345 and reverse biases CR1326. CR1344 is still reverse biased, but when B Sweep starts, the collector of Q1326 steps negative enough to forward bias CR1344 and add a slight amount of unblanking to the A Sweep unblanking already present. This provides a measure of intensification for the B Sweep portion of an A INTEN or MIX display. In the B DLY'D position of the HORIZ DISPLAY switch, -8 volts is applied to the cathodes of CR1327 and CR1347. This reverse biases both CR1345 and CR1326, which allows the full B Sweep unblanking signal to pass through CR1344. Since the A Sweep Z-Axis Gate output diode CR1342 is held reverse biased, the only unblanking signal present at the input to the Z-Axis Amplifier will be the B Sweep signal.

+A GATE And +B GATE Emitter Followers

Q1314 and Q1334 are emitter followers providing the +A GATE and +B GATE output signals available at the instrument rear panel. The output signals are positive-going rectangular waveforms, approximately 5.5 volts in amplitude. The amplitude is set in the collectors of Q1304 and Q1324. For example, when Q1304 is conducting the base of Q1314 can go no more negative than approximately -0.7 volt (limited by CR1304). When Q1304 is not conducting, the base of Q1314 rises to the decoupled +5 volts power supply level through R1304. CR1315, CR1316,

CR1335, and CR1336 provide protection against accidental application of damaging voltage levels to the +A GATE and +B GATE output connectors.

B Sweep Latch

Q822 and Q828 compose the B Sweep Latch. Quiescently, (before either the A or B Sweeps have reached their maximum amplitudes) both transistors are off. Then, the sweep reset pulse from whichever sweep terminates first will be applied to the base of Q828 (A Sweep reset through CR826; B Sweep reset through CR825). The positive-going reset pulse turns on Q828 and the negative-going movement at its collector turns on Q822. The collector of Q822 in turn pulls up on the base of Q828, holding Q828 on, which causes the circuit to stay in its on or latched state. The HI at the collector of Q822 is applied to the base of the B Sweep Holdoff Amplifier (through CR809) to disable the B Trigger Tunnel Diodes. In the B ENDS A position of the A TRIG HOLDOFF control the HI is also applied to the holdoff start input terminal of the Sweep Control IC through C286. Thus, when B Sweep ends A Sweep ends also.

The B Latch Multivibrator is reset to its quiescent state by the LO Holdoff level Present at pin 10 of the Sweep Control IC during A Sweep holdoff.

HORIZONTAL AMPLIFIER

General

The Horizontal Amplifier circuit provides the output signals to the CRT horizontal deflection plates. The signal applied to the input of the Horizontal Amplifier is determined by the TIME/DIV switch. The signal can be a sawtooth waveform generated within the instrument, or some external signal applied to the CH 1 OR X input connector (X-Y mode of operation). The Horizontal Amplifier also contains the X10 magnifier, horizontal positioning, and some beam finder circuitry. Fig. 3-7 shows a detailed block diagram of the Horizontal Amplifier circuit. A schematic of this circuit is shown on diagram 9 at the rear of this manual.

X-Axis Amplifier

In all positions of the TIME/DIV switches except X-Y, the input signal to the base of Q1224 will be the sawtooth waveforms from the sweep generators. In the X-Y mode however, the sweeps are disabled and the signal applied to Q1224 comes from the Channel 1 Preamp via the X-Axis Amplifier stage. This stage includes Q1214, Q1218, and their associated circuitry.

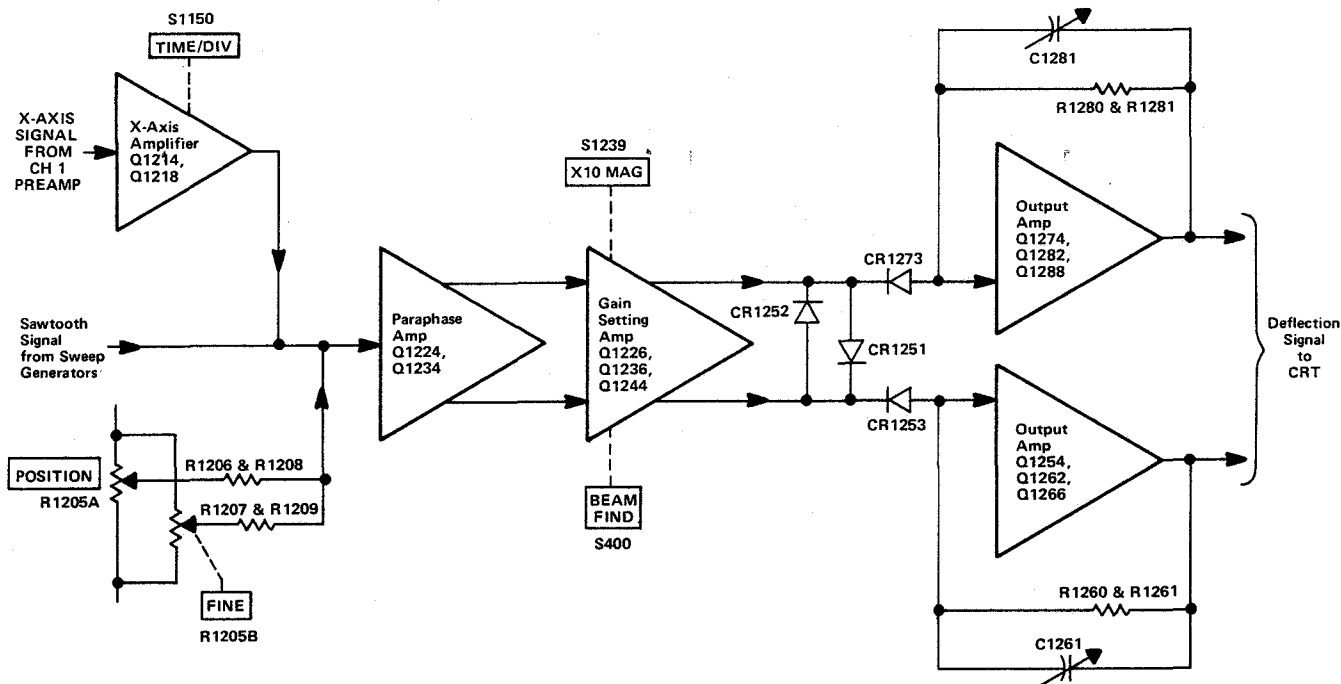

Fig. 3-7. Detailed block diagram of the Horizontal Amplifier.

Q1214 is connected as a feedback amplifier with R1214 as the feedback element. The input resistance is made up of R1211 and the gain-setting adjustment R1215. When not operating in the X-Y mode, the base of Q1214 rises toward the +15 volt supply but is clamped at approximately +5.7 volts by CR1216. This reverse biases the base-emitter junction of Q1214. The base of Q1218 also rises to approximately +5.7 volts. With the junction of R1202-R1219 sitting at approximately 0 volts, Q1218 is also biased off.

When the TIME/DIV switches are set to the X-Y position (fully counterclockwise), -8 volts is applied to the junction of R1212 and R1217. Also, +5 volts is applied to the emitter circuit of Q1218 through CR1202. This biases the Z-Axis Amplifier circuit into conduction. At the same time, +5 volts is applied to the Channel 1 Scale-Factor Switching Amplifier circuit (through CR1201) and to pin 18 of the Sweep Control Integrated Circuit U870. This enables both scale-factor indicating circuits at the same time and disables sweep generation.

Input Paraphase Amplifier

Q1224 and Q1234 compose the Input Paraphase Amplifier. This is an emitter-coupled amplifier stage that converts the single-ended input signal to a push-pull output signal. The signal at the collector of Q1224 is opposite in phase to the input signal. The signal at the collector of Q1234 is in phase with the input signal. Thermistor resistor RT1230 reduces in value with increases in ambient temperature to increase the gain of the stage. This compensates for changes in amplifier gain that occur as operating temperatures vary. R1205A and R1205B are the Horizontal POSITION and FINE controls, respectively. The FINE control has approximately one tenth the range of the POSITION control and provides fine adjustment of a magnified display.

Gain Setting Amplifier

Q1226 and Q1236 are an emitter coupled push-pull amplifier stage. Q1244 is a constant current supply for the stage. The gain of the Horizontal Amplifier is controlled by adjusting the resistance connected between the emitters of this stage. The X1 Gain adjustment R1237 adjusts unmagnified horizontal gain and the X10 Gain adjustment R1238 adjusts magnified horizontal gain. Magnifier Registration adjustment R1225 balances quiescent DC current in Q1226 and Q1236 so that a center screen display does not change position when the X10 Magnifier is turned on.

When the BEAM FIND pushbutton is pressed, R1249 is connected to ground. This reduces the current supplied through Q1244, which has the effect of shifting the operating level at the collector of Q1244 in the positive direction. This causes the Horizontal Amplifier to operate closer to the point where signal limiting occurs, thereby ensuring that an overscanned display will remain within the viewing area of the CRT.

Output Amplifier

The push-pull signal from the Gain Setting Amplifier is connected to the Output Amplifier through CR1253 and CR1273. Each half of the Output Amplifier can be considered as a single-ended feedback amplifier, which amplifies the signal current at the input to produce a voltage output to drive the horizontal deflection plates of the CRT. The amplifiers have a low input impedance and require very little voltage change at the input to produce the desired output change. The Output Amplifiers are limited from overdrive by CR1251, CR1252, CR1253, and CR1273. The input diodes CR1253 and CR1273 become back-biased when the signal level at either input becomes too positive, and the diodes connected back to back between the two signal paths ensure that the signal amplitude side to side will be limited to a maximum of about 0.7 volt.

Transistors Q1254 and Q1274 are inverting amplifier stages whose collector signals drive the emitters of complementary amplifiers Q1262-Q1266 and Q1282-Q1288 respectively. C1256, C1262, and C1282 provide a signal path for fast AC signal currents from one side of the amplifier to the other. R1260-R1261 and R1280-R1281 are the feedback elements in the amplifier with C1261 and C1281 providing high-frequency compensation. The output signal from Q1262-Q1266 drives the right CRT deflection plate, while the signal from Q1282-Q1288 drives the left.

CRT CIRCUIT

General

The CRT Circuit provides the voltage levels and control circuits necessary for operation of the cathode-ray tube (CRT). Fig. 3-8 shows a detailed block diagram of the CRT Circuit. A schematic of this circuit is shown on diagram 10 at the rear of this manual.

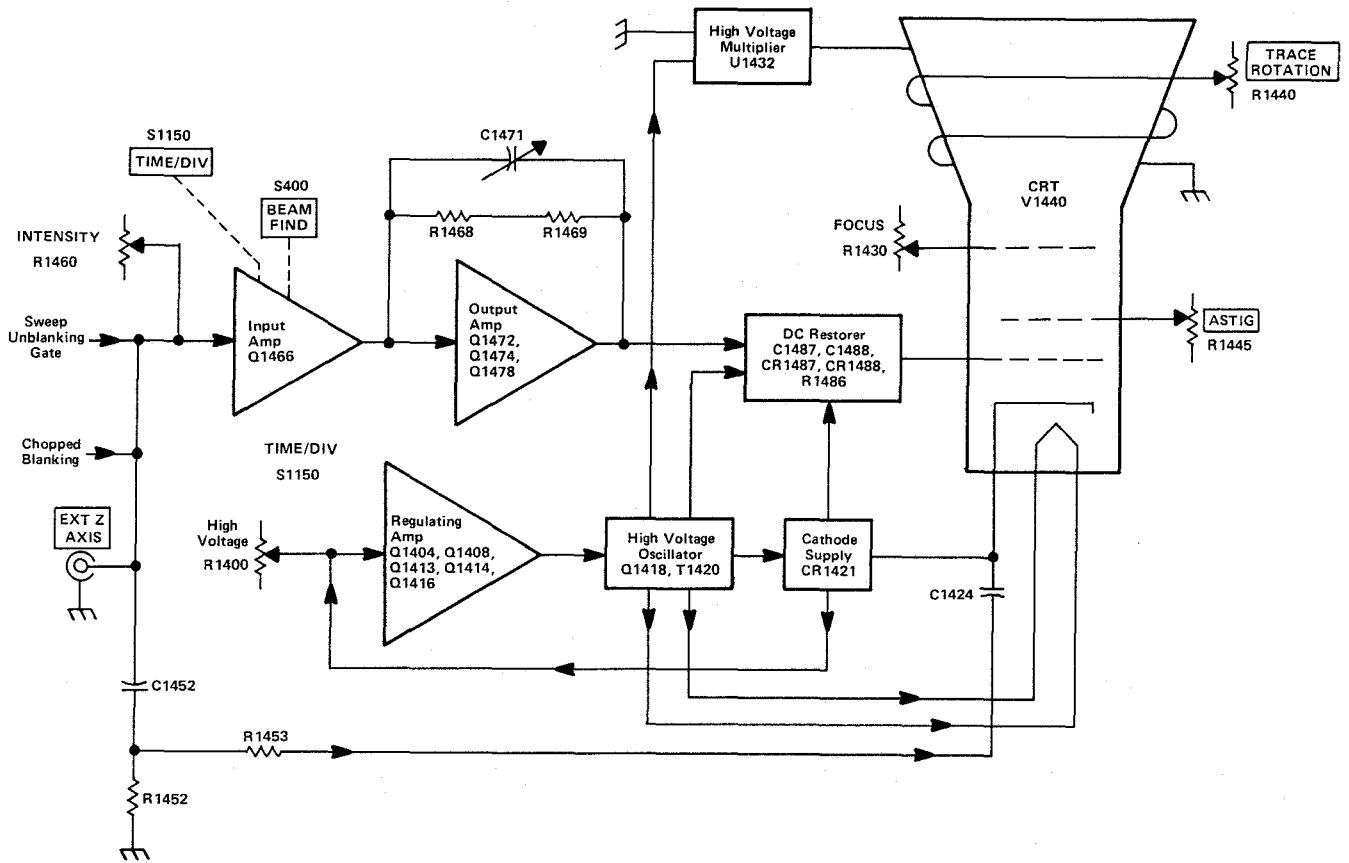

Fig. 3-8. Detailed block diagram of the CRT & Z-AXIS Circuits.

High-Voltage Oscillator

Q1418 and associated circuitry compose the high-voltage oscillator that produces the drive for high-voltage transformer T1420. When the instrument is turned on, current through Q1416 provides forward bias for Q1418. Q1418 conducts and the collector current increases, which develops a voltage across the collector winding of T1420. This produces a corresponding voltage increase in the feedback winding of T1420, which is connected to the base of Q1418, and Q1418 conducts even harder. Eventually the rate of collector current increase in Q1418 becomes less than that required to maintain the voltage across the collector winding, and the output voltage drops. This turns off Q1418 by way of the feedback voltage to the base. The voltage waveform at the collector of Q1418 is a sine wave at the resonant frequency of T1420. Q1418 remains off during the negative half cycle while the field collapses in the primary of T1420. When the field is collapsed sufficiently, the base of Q1418 becomes forward biased into conduction again and the cycle begins anew. The amplitude of sustained oscillation depends upon the average current delivered to the base of Q1418. The frequency of oscillation is approximately 50 kilohertz. Fuse F1419 protects the +15 volt supply in the event the High-Voltage Oscillator stage becomes shorted. C1419 and L1419 decouple the +15

volt supply line and prevent the current changes present in the circuit from affecting the +15 volt regulator.

High-Voltage Regulator

Feedback from the CRT cathode -2450 volt supply is applied to the base of Q1404 through R1431D. Any change in the level at the base of Q1404 produces an error signal at the collector of Q1404, which is amplified by Q1408 and Q1416 and applied to the base of Q1418 through the feedback winding of T1420. Regulation occurs as follows.

If the output voltage at the -2450 volt test point starts to go positive (less negative), this positive-going change is applied to the base of Q1404. Q1404 conducts harder, which in turn causes Q1408 and Q1416 to conduct harder. This results in greater bias current to the base of Q1418 through the feedback winding of T1420. Now, Q1418 is biased closer to its conduction level so that it comes into conduction sooner to produce a larger induced voltage in the secondary of T1420. This increased voltage appears as a more negative voltage at the -2450 volt test point to correct the original positive-going change. By sampling the

output from the CRT cathode supply in this manner, the total output of the High-Voltage Supply is held relatively constant.

The output voltage levels of the High-Voltage Supply are controlled by the High Voltage Adjustment R1400 in the base circuit of Q1404. This adjustment sets the conduction of Q1404 to a level that establishes a -2450 volt operating potential at the CRT cathode.

Q1413 and Q1414 compose an overvoltage protection circuit. In the event the regulating action of the circuit should cause the CRT cathode supply to approach approximately -3000 volts, the voltage level at the emitter of Q1416 will be very close to -6 volts. Normally Q1413 and Q1414 are biased off and do not conduct. When the voltage level at the emitter of Q1416 reaches approximately -6 volts, Q1413 is biased into conduction which in turn biases Q1414 on. Q1414 now starts to reduce the base drive applied to Q1418 and prevents the amplitude of oscillations from increasing. This prevents the CRT cathode supply from going more negative than approximately -3000 volts.

High-Voltage Rectifiers and Output

The high-voltage transformer T1420 has two output windings. One winding provides filament voltage for the cathode-ray tube. The filament voltage can be supplied from the High-Voltage Supply, since the cathode-ray tube has a very low filament current drain. The cathode and filament of the CRT are connected together to elevate the filament and prevent cathode-to-filament breakdown. One high-voltage winding provides both the negative cathode potential and the positive anode accelerating voltage. The CRT grid bias voltage is derived by a DC restorer circuit that uses a sample of the signal in the high-voltage winding in conjunction with DC levels supplied by the Z-Axis Amplifier and the negative cathode potential.

The positive accelerating potential is supplied by High Voltage Multiplier U1432. Regulated output voltage is approximately +15,500 volts. The negative cathode potential is supplied by half-wave rectifier CR1241. Voltage output is -2450 volts. Voltage variations in this supply are monitored by the High-Voltage Regulator circuit to provide a regulated high-voltage output.

CRT Control Circuits

Focus of the CRT display is controlled by FOCUS control R1430. ASTIG adjustment R1445, which is used in conjunction with the FOCUS control to provide a well-defined display, varies the positive level on the astigmatism grid. Geometry adjustment R1442 varies the positive level

on the horizontal deflection plate shields to control the overall geometry of the display.

Two adjustments control the trace alignment by varying the magnetic field around the CRT. Y Axis adjustment R1446 controls the current through L1446, which affects the CRT beam after vertical deflection, but before horizontal deflection. Therefore, it affects only the vertical (Y) components of the display. TRACE ROTATION adjustment R1440 controls the current through L1440 and affects both vertical and horizontal rotation of the beam.

Z-Axis Amplifier

The Z-Axis Amplifier circuit controls the CRT intensity level from several inputs. The effect of these input signals is to either increase or decrease the trace intensity, or to completely blank portions of the display. The input transistor Q1466 is a current-driven, low input impedance amplifier. It provides termination for the input signals as well as isolation between the input signals and the following stages. The current signals from the various control sources are connected to the emitter of Q1466 and the algebraic sum of the signals determines the collector conduction level.

Q1472, Q1474, and Q1478 compose a feedback amplifier stage; R1468 and R1469 are the feedback elements. C1469 and C1471 provide high frequency compensation. Q1472 is an emitter follower providing drive to complementary amplifier Q1474-Q1478. CR1468, CR1472, and CR1476 provide protection in the event of high-voltage arcing.

In the .1 s, .2 s, .5 s, and X-Y positions of the TIME/DIV switch, +5 volts is connected to the anode of CR1463. This limits the effective range of the INTENSITY control to reduce the unblanking capabilities of the amplifier, thereby reducing the possibility of inadvertently burning the CRT phosphor. When the BEAM FIND pushbutton is pressed, two things occur: First, +15 volts is applied to the anode of CR1465 which lifts the emitter of Q1466 sufficiently positive to ensure there will be no conduction through Q1466. Secondly, R1470 becomes connected to -8 volts through R1477 which establishes a fixed predetermined unblanking level at the output of the amplifier. Thus, the INTENSITY control and all of the input unblanking signals have no control over the intensity level of the CRT display when the BEAM FIND pushbutton is pressed.

DC Restorer Circuit

C1488, C1487, CR1487, CR1488, and R1486 form a DC restorer circuit. All DC levels in this circuit are

referenced to the negative potential of the CRT cathode. The voltage difference across R1486 approximately equals the voltage swing present at the junction of CR1482 and CR1483. The control grid end of R1486 is more negative than the end connected to CR1488. The amplitude of the voltage swings present at the junction of CR1482 and CR1483 is determined by the voltage levels established by the Z-Axis Amplifier and the CRT Bias adjust circuit. CR1483 sets the limit of the positive excursion and CR1482 sets the limit of the negative excursion.

CALIBRATOR

General

The Calibrator circuit produces a square-wave output signal with accurate voltage and current amplitudes. This output is available as a voltage or current at the CALIBRATOR current loop on the instrument front panel. Fig. 3-9 shows a detailed block diagram of the Calibrator circuit. A schematic of this circuit is shown on diagram 11 at the back of this manual.

Multivibrator

Q1590 and Q1594 along with their associated circuitry compose an astable multivibrator. The basic frequency of the multivibrator is approximately one kilohertz and is essentially determined by the RC combination of C1592, R1591, and R1593. Q1590 and Q1594 alternately conduct, producing a square-wave output signal, which is taken from the collector of Q1594. The amplitude of the square wave is limited in the negative direction by the base-emitter junction of Q1598 and in the positive direction by CR1596.

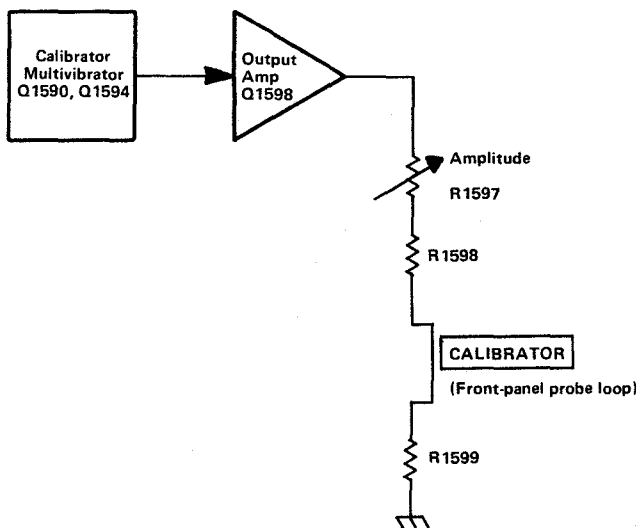

Fig. 3-9. Detailed block diagram of the Calibrator circuit.

Output Amplifier

The output signal from the Multivibrator overdrives Output Amplifier Q1598 to produce an accurate square wave at the output. When the base of Q1598 goes positive Q1598 is cut off and the collector level drops down to ground. When the base goes negative Q1598 is biased into saturation and the collector of Q1598 rises positive to about +5 volts. Amplitude adjustment R1597 adjusts the resistance between the collector of Q1598 and ground to determine the amount of current allowed to flow, which in turn determines the voltage developed across R1599.

A TRIGGER VIEW AMPLIFIER

General

The A Trigger View Amplifier circuit amplifies a sample of the signal present in the A Trigger Generator circuit and passes it on to the Vertical Output Amplifier for display on the CRT when the TRIG VIEW pushbutton is pressed. This provides a method of making a quick and convenient check of the signal being used to trigger the A Sweep Generator and is intended primarily to be used to check the signal applied to the A External Trigger Input connector. Fig. 3-10 shows a detailed block diagram of the A Trigger View Amplifier circuit. A schematic of this circuit is shown on diagram 11 at the back of this manual.

Amplifier

The amplifier consists of two emitter-coupled push-pull amplifier stages. The emitter source voltage for Q672 and Q682 is switched on and off by the TRIG VIEW pushbutton. With the TRIG VIEW pushbutton not pressed, the emitters of Q672 and Q682 are returned to -8 volts through R691. This reverse-biases the base-emitter junctions of the transistors, preventing any loading of the A Trigger Generator circuit. When the TRIG VIEW pushbutton is pressed, the emitters of Q672 and Q682 are returned to +15 volts through R690. This forward biases

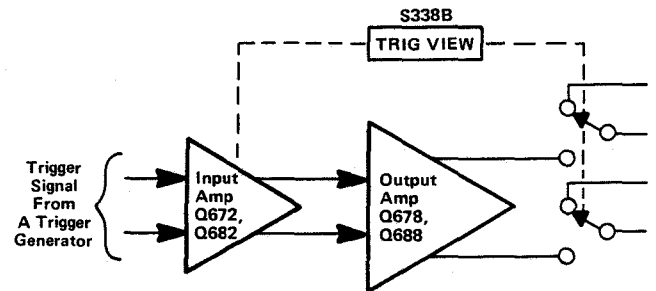

Fig. 3-10. Detailed block diagram of the Trigger View Amplifier.

Q672 and Q682 to allow signal amplification. R675 adjusts for correct DC balance in the circuit.

Normally, the output of the Vertical Switching Amplifier is applied to the input of the Delay Line. When the TRIG VIEW pushbutton is pressed, the signal from the Vertical Switching Amplifier is removed and the output from the A Trigger View Amplifier is applied in its place.

LOW-VOLTAGE POWER SUPPLY

General

The Low-Voltage Power Supply circuit provides the operating power for this instrument from four regulated supplies and one unregulated supply. Electronic regulation is used to provide stable, low-ripple output voltages. Fig. 3-11 shows a detailed block diagram of the Power Supply circuit. A schematic of this circuit is shown at the back of this manual.

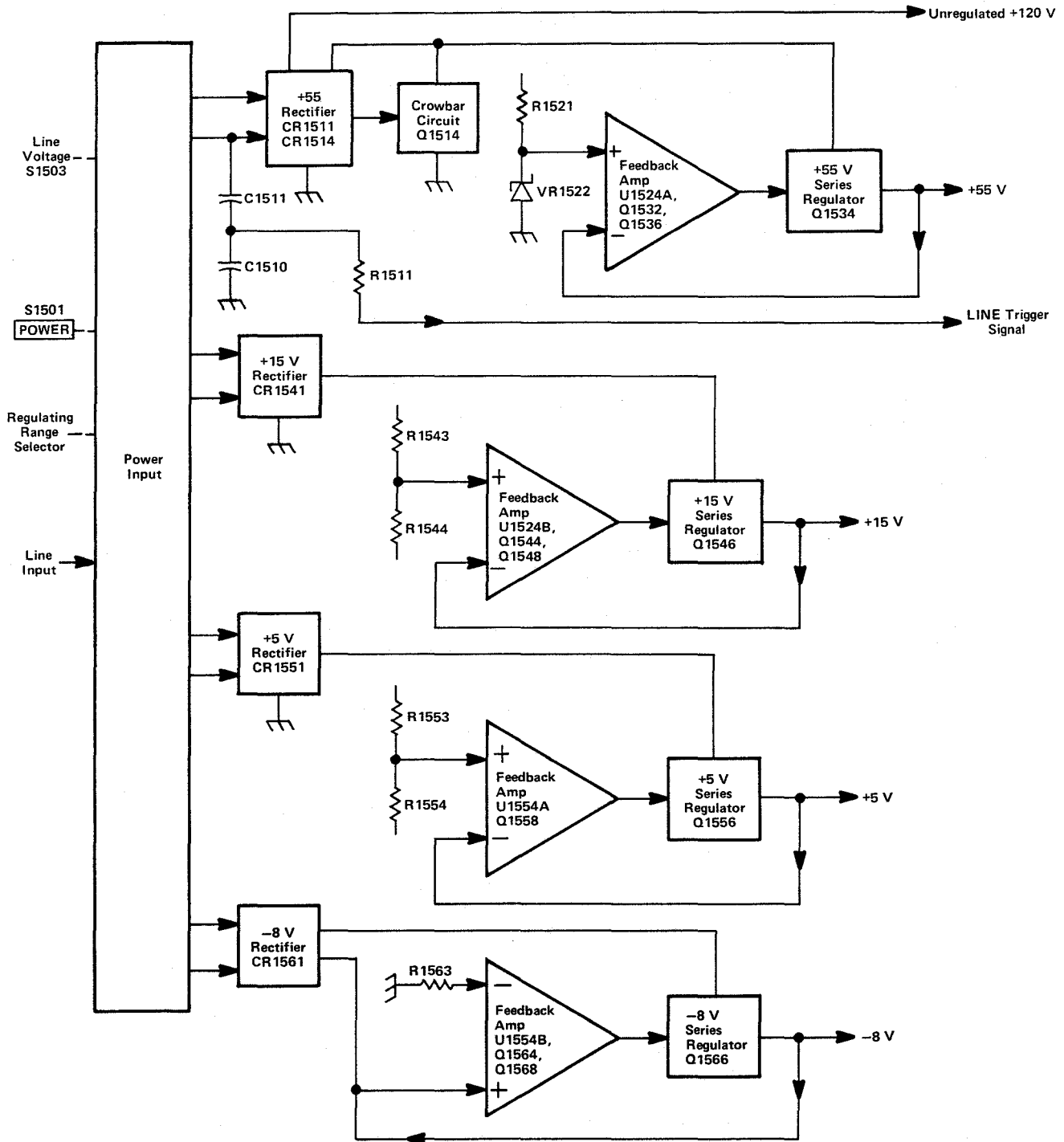

Fig. 3-11. Detailed block diagram of the Low Voltage Power Supply.

Power Input

Power is applied to the primary of transformer T1501 through Line Fuse F1501, POWER switch S1501, Thermal Cutout S1502, Line Voltage Selector switch S1503, and the Regulating Range Selector Assembly. Line Voltage Selector switch S1503 connects the split primaries of T1501 in parallel for 115-volt nominal operation, or in series for 230-volt nominal operation. Line Fuse F1501 should be changed to the correct value to provide the correct protection for each nominal line voltage (current rating of fuse for 230-volt operation is one-half the current rating of fuse for 115-volts).

The vacant windings between pins 10, 11, and 12 of T1501 are intended for use with the optional Inverter Circuit Board (Option 7). This allows the instrument to be operated from an external DC power source or an 1106 Power Supply.

Secondary Circuit

The -8 volt, +5 volt, +15 volt, and +55 volt supplies are series-regulated supplies. U1524A and B and U1554A and B are high-gain amplifier cells with differential inputs. These amplifiers monitor voltage variations in the output voltages.

For SN B080000 and up, a regulated +110 V supply is provided in addition to the unregulated +120 V supply. Both are derived from the terminal 14, 15, and 16 winding of T1501 and the full wave bridge rectifier CR1511. The +110 V regulated supply is referenced to the +55 V regulated supply via 56 V zener diode VR1515 and CR1514 to the base of series regulator transistor Q1516. Q1516 collector is fed from the +120 V supply through CR1516. R1516 shunts Q1516 to provide additional +110 V supply current. Q1518 provides short circuit protection by limiting the current through Q1516 during overload conditions.

Below SN B080000, the +120 V unregulated supply functions in place of the +110 V and +120 V supplies of later production. This +120 V supply includes SCR Q1514 to provide over-voltage protection for the various +120 V loads in the event of higher than specified line voltage levels. This Q1514 "Crowbar" circuit places a short across the T1501 secondary winding which will cause fuse F1501 to blow within 40 milliseconds if the line voltage exceeds the range selected on the T1501 primary taps. Fuse F1501 should always be replaced with the specified value to protect Q1514. If Q1514 is destroyed due to too high F1501 value, the +120 V supply can rise to about 160 V and possibly damage components in the +120 V load circuitry.

C1510, C1511, and R1511 compose a wave-shaping circuit that provides a sample of the AC voltage present in the secondary of T1501 to the trigger circuitry for use in the LINE positions of the Trigger SOURCE switches. CR1512 provides a relatively fast discharge path for C1542 when instrument power is turned off.

FAN MOTOR CIRCUIT

General

The fan motor used in the 465 is a brushless DC fan motor using Hall Effect devices. The fan motor circuitry varies the rotational speed of the fan with variations in operating temperature. When the ambient temperature increases, the value of thermistor RT1696 reduces. This biases Q1698 on harder to conduct more current through the Hall devices. Higher currents through the Hall devices causes the potential difference across them (for instance, between pins 6 and 8 of the fan) to increase. This potential difference biases one of a pair of transistors on and the other off. For instance, if pin 8 is more positive than pin 6 of the fan, Q1690A will be on and Q1690D will be off. The higher the potential difference between pin 8 and pin 6 the harder the on transistor will be conducting. The harder the transistor is conducting, the faster the fan rotates.

MAINTENANCE

Cabinet Removal

WARNING

Dangerous potentials exist at several points throughout this instrument. When the instrument is operated with the cover removed, do not touch exposed connections or components. Some transistors may have elevated cases. Disconnect power before cleaning the instrument or replacing parts.

The instrument wrap-around cabinet can be removed in the following manner:

1. Unwrap the power cord from the instrument feet.
2. Remove the six screws indicated in Fig. 4-1 and remove the instrument feet and rear ring assembly from the instrument.
3. Slide the wrap-around cabinet to the rear and remove the oscilloscope.

To replace the instrument in its wrap-around cabinet, reverse the removal procedure. The portable wrap-around cabinet should be installed with the carrying handle pivot points positioned toward the bottom of the instrument.

PREVENTIVE MAINTENANCE

General

Preventive maintenance consists primarily of cleaning and visual inspection. When performed on a regular basis, preventive maintenance can prevent instrument breakdown and will improve the reliability of this instrument. The severity of the environment to which the 465 is subjected will determine the frequency of maintenance. A convenient time to perform preventive maintenance is just prior to recalibration of the instrument.

Cleaning

General. The 465 should be cleaned as often as operating conditions require. Accumulation of dirt in the instrument can cause overheating and component breakdown. Dirt on

components acts as an insulating blanket and prevents efficient heat dissipation. It also provides an electrical conduction path which can result in instrument failure.

The cabinet provides protection against dust in the interior of the instrument. Operation without the cabinet in place necessitates more frequent cleaning. The front cover provides a measure of dust protection for the front panel and the CRT face. The front cover should be installed when storing or transporting the instrument.

CAUTION

Avoid the use of chemical cleaning agents which might damage the plastics used in this instrument. Avoid chemicals which contain benzene, toluene, xylene, acetone or similar solvents. Recommended cleaning agents are isopropyl alcohol or Kelite (1 part Kelite, 20 parts water).

Switch Contacts. Most of the switching in the 465 is accomplished with circuit-board mounted, cam-actuated contacts. Care must be exercised to preserve the high-frequency characteristics of these switches. Seldom is switch maintenance necessary, but if it is required, observe the following precautions.

Cleaning the switch contacts should only be done using isopropyl alcohol or a solution of one part Kelite to 20 parts water. In the absence of these three cleaners it is safe to use petroleum ether, white kerosene, or a solution of 1% Joy detergent and 99% water. Do not use acetone, MEK, MIBK, benzol, toluol, carbon tetrachloride,

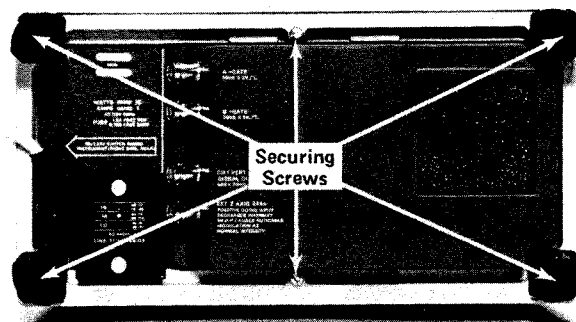

Fig. 4-1. Removing wrap-around cabinet.

trichlor, trichlene, methyl alcohol, methylene chloride, sulfuric acid, or Freon TC-TE-TF-22-TA-12.

Most spray circuit coolants and contact cleaners contain Freon 12 as a propellant. Because many Freons adversely affect the contacts, check the contents before using a spray cleaner or coolant. An acceptable contact cleaner-restorer is No Noise (Electronic Chemical). The only recommended circuit coolants are dry ice or isopropyl alcohol. There are three recommended switch lubricants. They are Silicone Versilube (General Electric Co.), Rykon R (Standard Oil, and WD-40 (Rocket Chemical Co.).

Exterior. Loose dust accumulated on the outside of the 465 can be removed with a soft cloth or small paint brush. The paint brush is particularly useful for dislodging dirt on and around the front-panel controls. Dirt which remains can be removed with a soft cloth dampened in a mild detergent and water solution. Abrasive cleaners should not be used.

CRT. Clean the blue and clear plastic light filters and the CRT face with a soft, lint-free cloth dampened with denatured alcohol or a mild detergent and water solution. The optional CRT mesh filter can be cleaned in the following manner.

1. Hold the filter in a vertical position and brush lightly with a soft No. 7 watercolor brush to remove light coatings of dust and lint.
2. Greasy residues or dried-on dirt can be removed with a solution of warm water and a neutral pH liquid detergent. Use the brush to lightly scrub the filter.
3. Rinse the filter thoroughly in clean water and allow to air dry.
4. If any lint or dirt remains, use clean low-pressure air to remove. Do not use tweezers or other hard cleaning tools on the filter as the special finish may be damaged.
5. When not in use, store the mesh filter in a lint-free dust-proof container such as a plastic bag.

Interior. Dust in the interior of the instrument should be removed occasionally due to its electrical conductivity under high-humidity conditions. The best way to clean the interior is to blow off the accumulated dust with dry,

low-pressure air. Remove any dirt that remains with a soft paint brush or a cloth dampened with a mild detergent and water solution. A cotton-tipped applicator is useful for cleaning in narrow spaces or for cleaning circuit boards.

Lubrication

The fan motor and most of the potentiometers used in the 465 are permanently sealed and generally do not require periodic lubrication. The switches used in the 465, both cam- and lever-type, are installed with proper lubrication applied where necessary and will only rarely require any additional lubrication. It is recommended that a regular periodic lubrication program not be performed on any of the components used in the 465.

Transistor Checks

Periodic checks of the transistors and other semiconductors in the 465 are not recommended. The best check of semiconductor performance is actual operation in the instrument.

Recalibration

To assure accurate measurements, check the calibration of this instrument after each 1000 hours of operation or every six months if used infrequently. In addition, replacement of components may necessitate recalibration of the affected circuits. Complete calibration instructions are given in the Calibration section.

The calibration procedure can also be helpful in localizing certain troubles in the instrument. In some cases, minor troubles may be revealed or corrected by recalibration.

CORRECTIVE MAINTENANCE

General

Corrective maintenance consists of component replacement and instrument repair. Special techniques required to replace components in this instrument are given here.

Obtaining Replacement Parts

Standard Parts. All electrical and mechanical part replacements for the 465 can be obtained through your local TEKTRONIX Field Office or representative. However, many of the standard electronic components can be obtained locally in less time than is required to order them

from Tektronix, Inc. Before purchasing or ordering replacement parts, check the parts list for value, tolerance, rating, and description.

NOTE

When selecting replacement parts, it is important to remember that the physical size and shape of a component may affect its performance in the instrument, particularly at high frequencies. All replacement parts should be direct replacements unless it is known that a different component will not adversely affect instrument performance.

Special Parts. In addition to the standard electronic components, some special components are used in the 465. These components are manufactured or selected by Tektronix, Inc. to meet specific performance requirements, or are manufactured for Tektronix, Inc. in accordance with our specifications. These special components are indicated in the Electrical Parts List by an asterisk preceding the part number. Most of the mechanical parts used in this instrument have been manufactured by Tektronix, Inc. Order all special parts directly from your local TEKTRONIX Field Office or representative.

Ordering Parts. When ordering replacement parts from Tektronix, Inc., it is imperative that all of the following information be included in the order to ensure receiving the proper parts.

1. Instrument type.
2. Instrument serial number.
3. A description of the part (if electrical, include the circuit number).
4. TEKTRONIX Part number.

Soldering Techniques

WARNING

Always disconnect the instrument from the power source before attempting to solder in the instrument.

Ordinary 60/40 solder and a 35- to 40-watt pencil-type soldering iron can be used to accomplish the majority of the soldering to be done in the 465. If a higher wattage-rated soldering iron is used on the etched circuit boards, excessive heat can cause the etched circuit wiring to separate from the board base material.

CAUTION

The Vertical Preamplifier Attenuator circuit boards are made of material easily damaged by excessive heat. When soldering to these boards, do not use a

soldering iron with a rating of more than approximately 15 watts. Avoid prolonged applications of heat to circuit-board connections. Use only isopropyl alcohol when cleaning this circuit board.

When soldering to the ceramic strips in the instrument a slightly larger soldering iron can be used. It is recommended that a solder containing about 3% silver be used when soldering to these strips to avoid destroying the bond to the ceramic material. This bond can be broken by repeated use of ordinary tin-lead solder or by the application of too much heat; however, occasional use of ordinary solder will not break the bond if excessive heat is not applied.

If it becomes necessary to solder in the general area of any of the high-frequency contacts in the instrument, clean the contacts immediately upon completion of the soldering. Refer to the section entitled Switch Contacts under PREVENTIVE MAINTENANCE for recommended cleaners and procedures.

Component Replacement

WARNING

Always disconnect the instrument from the power source before attempting to replace components.

Circuit Board Replacement. Occasionally it may be necessary to gain access to the reverse side of a circuit board or to remove one circuit board to gain access to another. The following procedures outline the necessary steps to facilitate instrument disassembly. Most of the connections to the circuit boards in the instrument are made with pin connectors. However, some connections are soldered to the board. Observe the soldering precautions given under Soldering Techniques in this section.

Vertical Preamp Assembly Removal.

1. Remove the instrument wrap-around cabinet in the manner given under Cabinet Removal earlier in this section.
2. Remove the knobs from the VOLTS/DIV switches and from the Input Coupling Switches. The knobs on the VOLTS/DIV switches must have a setscrew in each one loosened (using a 1/16" Allen wrench) before they can be removed, while the knobs on the Input Coupling switches can be pulled off by hand.
3. Disconnect the vertical POSITION control shaft couplers from the vertical POSITION potentiometers (.050" Allen wrench required).

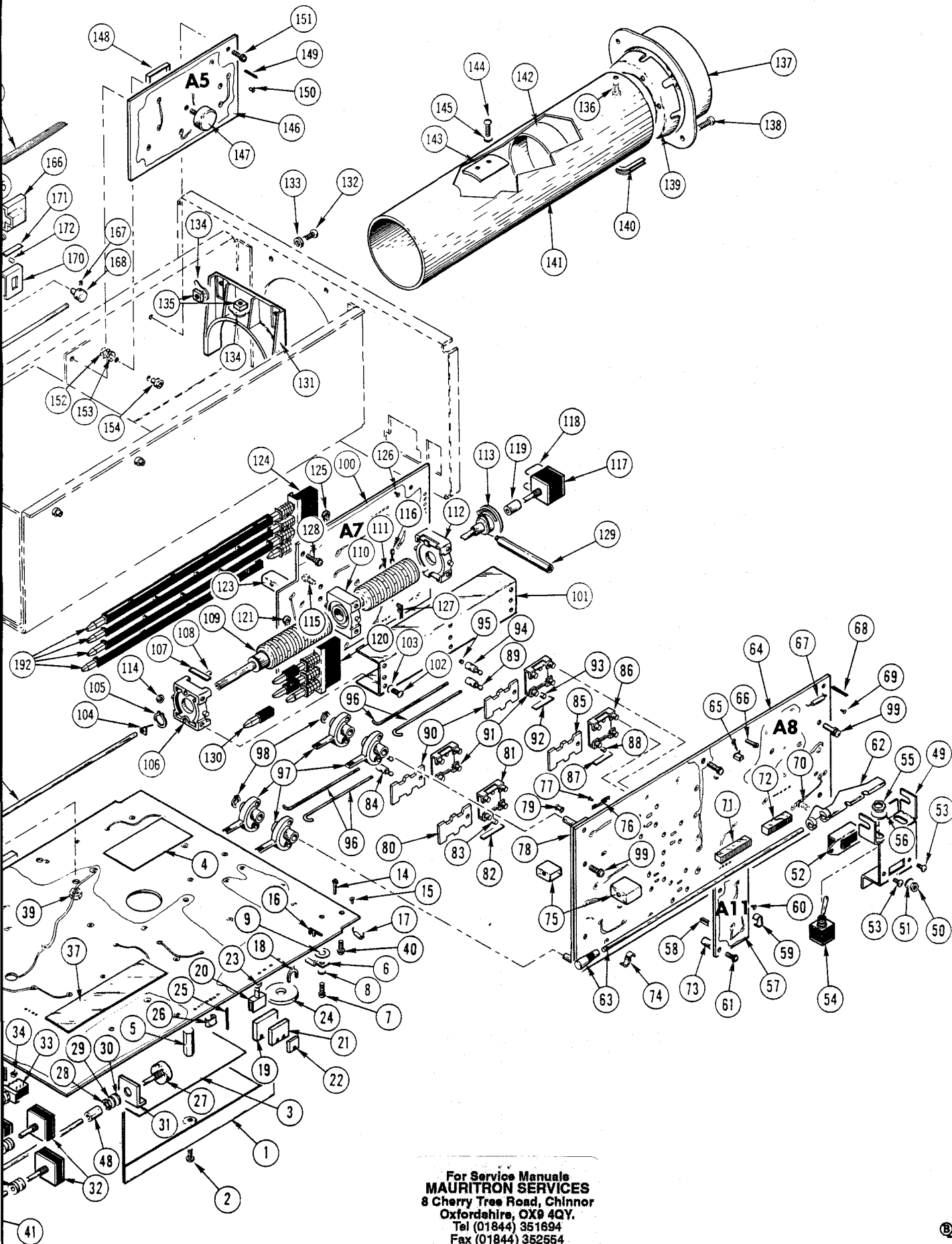

For Service Manuals
MAURITRON SERVICES
 8 Cherry Tree Road, Chinnor
 Oxfordshire, OX9 4QY.
 Tel (01844) 351694
 Fax (01844) 352554
 email: mauritron@dial.pipex.com

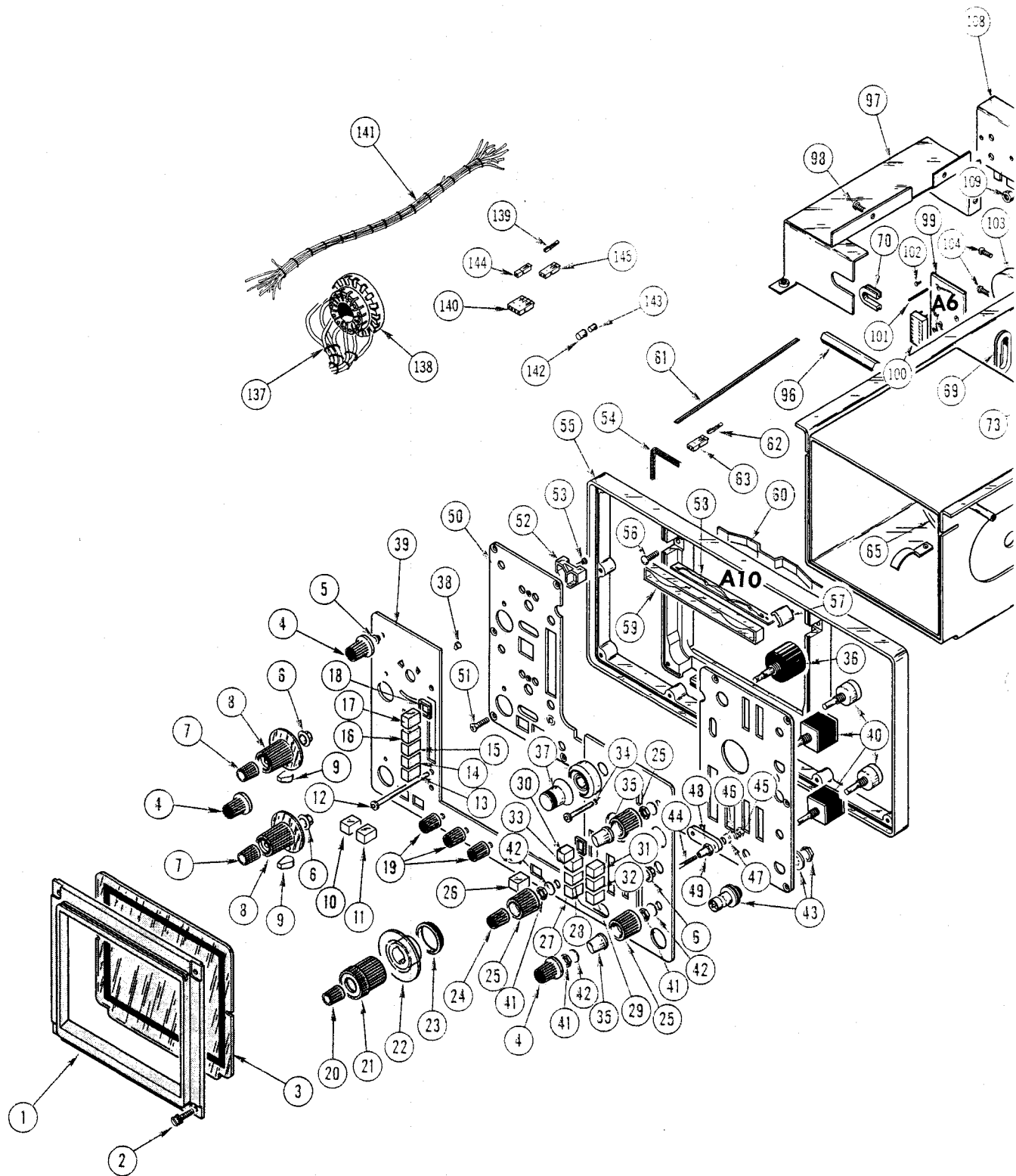

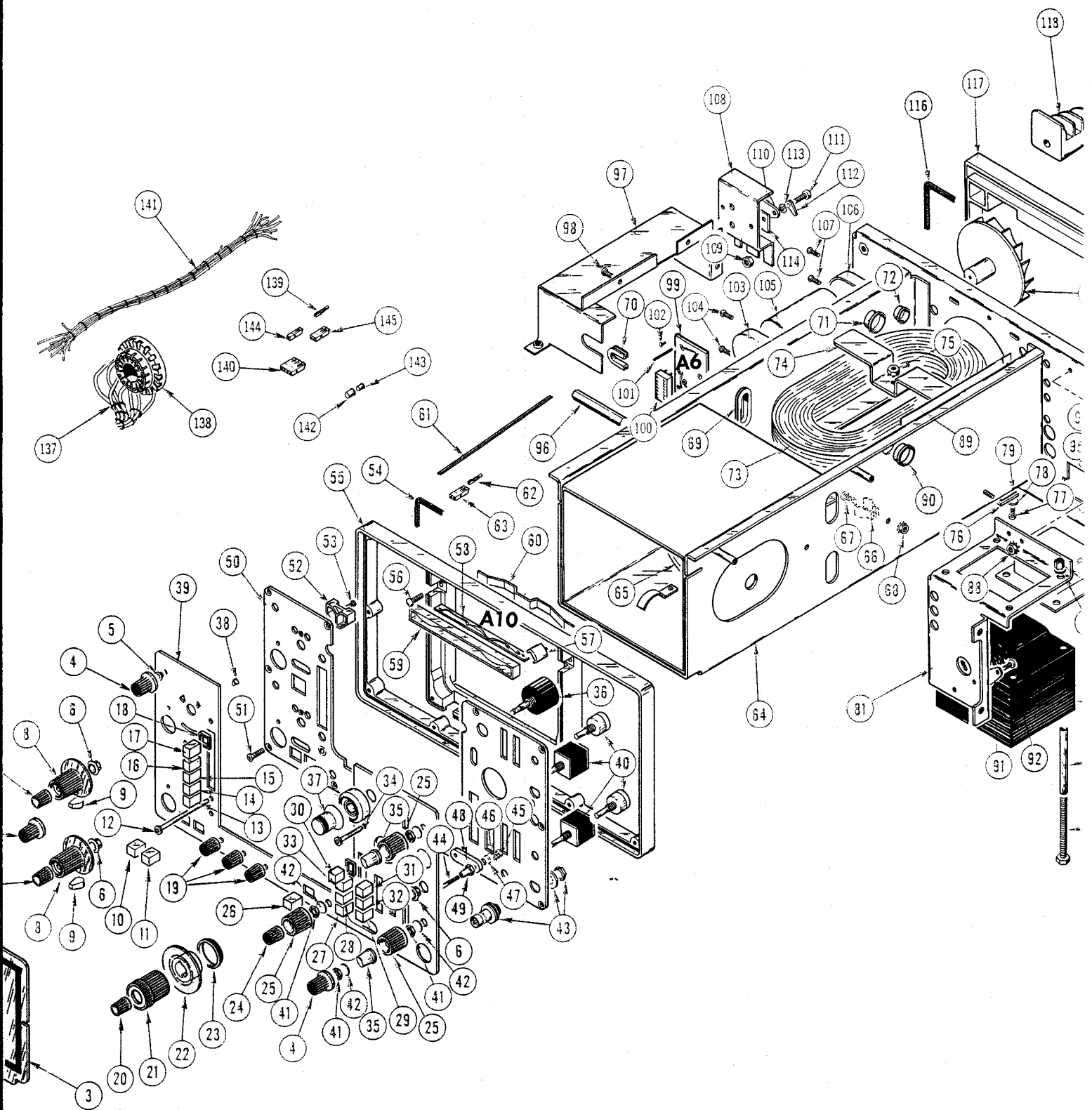

CABINET

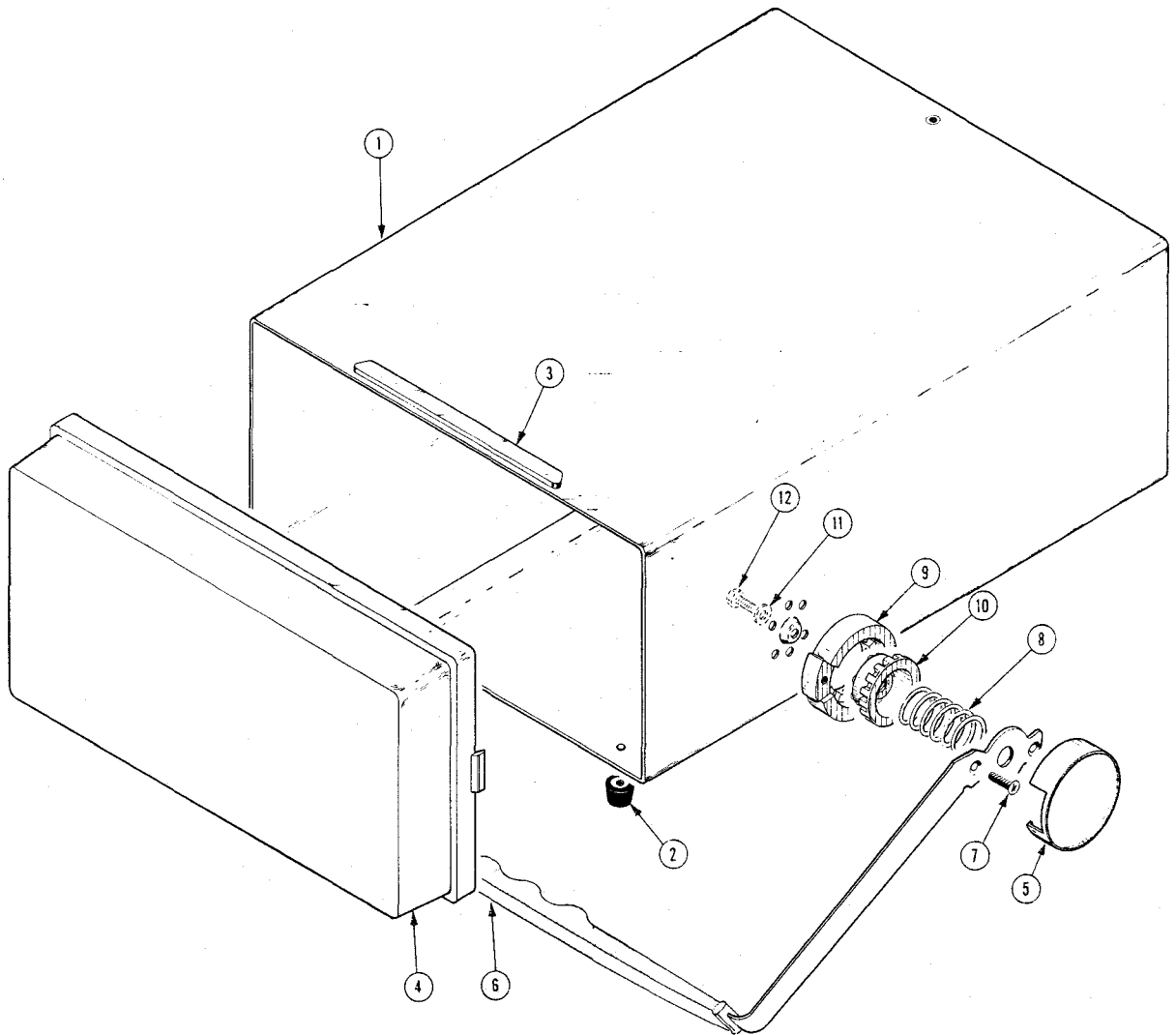

Fig. & Index No.	Tektronix Part No.	Serial/Model No. Eff	Dscnt	Qty	1 2 3 4 5					Name & Description	Mfr	
											Code	Mfr Part Numl
-1	437-0141-00			1						CABINET, SCOPE:	80009	437-0141-00
-2	348-0080-01			4						FOOT, CABINET:	80009	348-0080-01
-3	352-0263-00			1						HLDR, POUCH ASSY:	80009	352-0263-00
-4	200-1412-00			1						COVER, SCOPE: FRONT	80009	200-1412-00
-5	200-0602-00			2						COVER, HINGE:	80009	200-0602-00
-6	367-0140-03			1						HANDLE, CARRYING:	80009	367-0140-03
										(ATTACHING PARTS)		
-7	211-0512-00			4						SCREW, MACHINE: 6-32 X 0.50" 100 DEG, FLH STL	83385	OBD
										-----*		
	334-1998-00			1						PLATE, IDENT:	80009	334-1998-00
-8	214-0516-00			2						SPRING, HLCPS: 0.959 DIA X 1.250 INCH LONG	80009	214-0516-00
-9	214-0513-00	B010100	B130599	2						INDEX, HDL RING:	80009	214-0513-00
	214-0513-04	B130600		2						INDEX, HDL RING:	80009	214-0513-04
-10	214-0515-00	B010100	B130599	2						GEAR, HDL INDEX:	80009	214-0515-00
	214-0515-02	B130600		2						GEAR, HDL INDEX:	80009	214-0515-02
										(ATTACHING PARTS FOR EACH)		
-11	210-0805-00	B010100	B099999	1						WASHER, FLAT: 0.204 ID X 0.438 INCH OD, STL	12327	OBD
	210-1182-00	B100000		1						WSHR, SPR TNSN: 0.218 ID X 0.69 INCH OD	80009	210-1182-00
-12	213-0139-00			1						SCR, CAP, HEX HD: 10-24 X 0.375 INCH LONG	14438	OBD
										-----*		

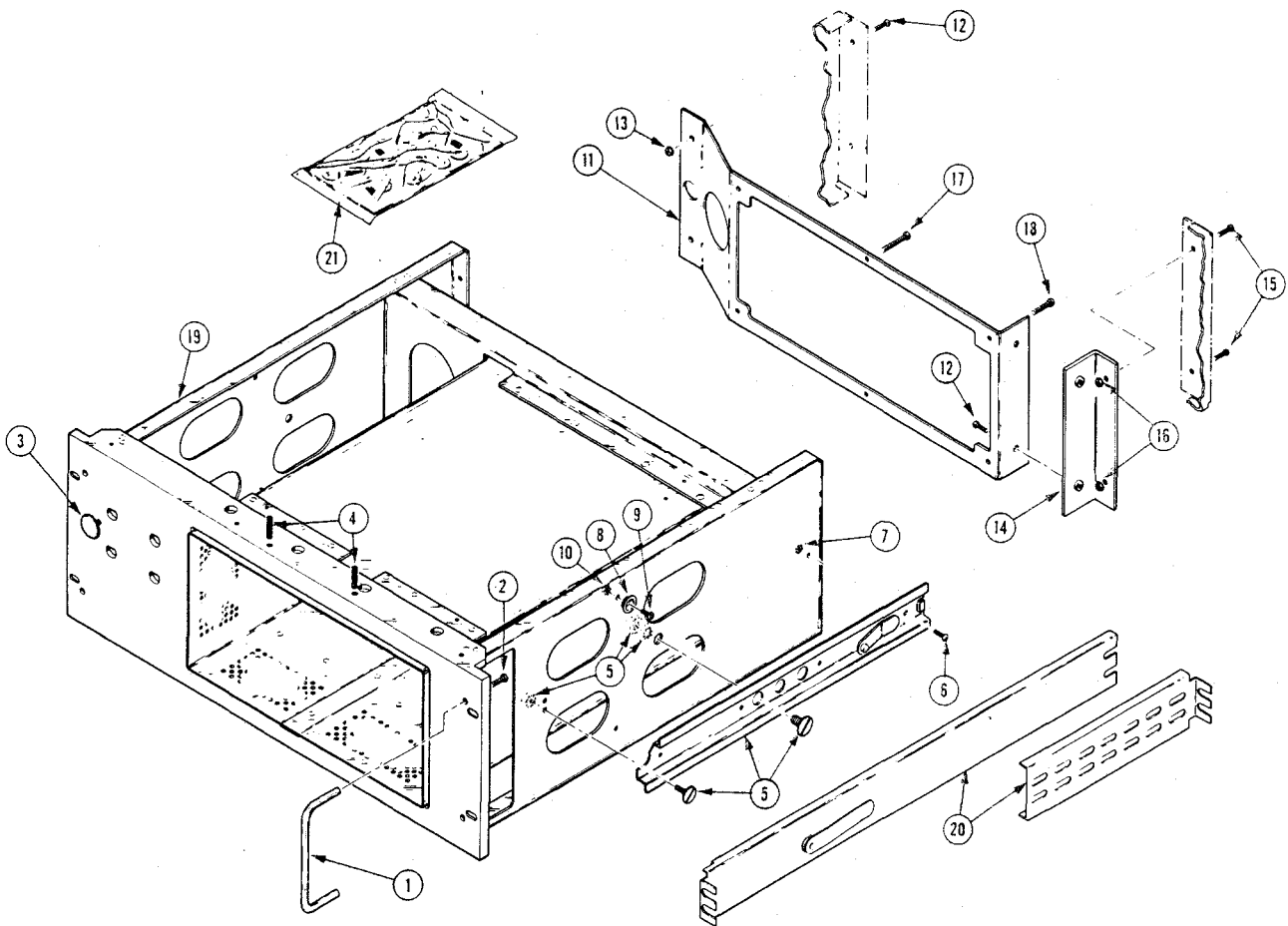
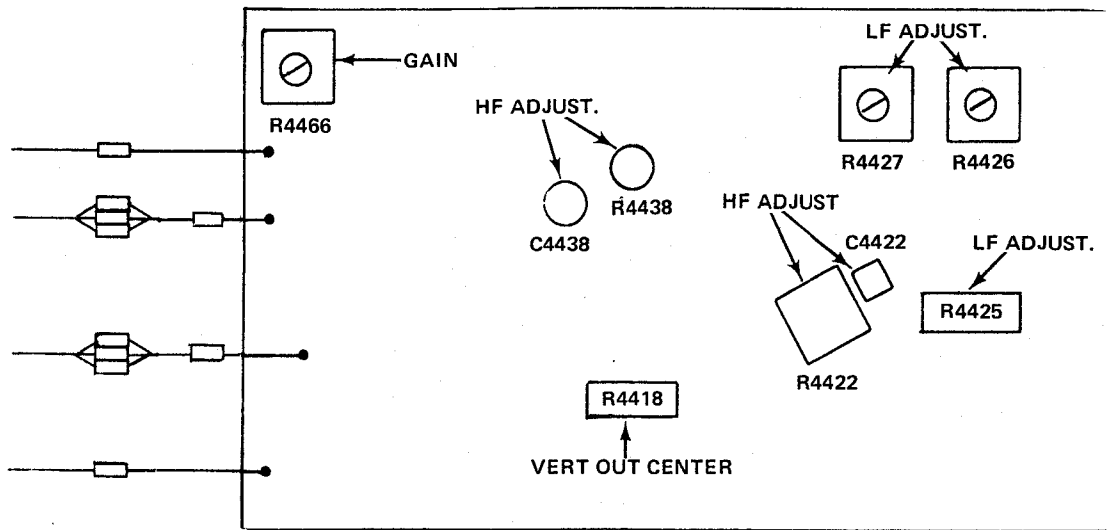

Fig. &
Index
No.

Index No.	Tektronix Part No.	Serial/Model No. Eff	Dscnt	Qty	Name & Description					Mfr Code	Mfr Part Number
					1	2	3	4	5		
4-	016-0556-00			1	ADPTR, RACK MTG:KIT					80009	016-0556-00
-1	367-0022-00			2	. HANDLE, BOW:1.5 X 4.5 INCH (ATTACHING PARTS FOR EACH)					06540	10353-B-1032-25A
-2	213-0090-00			2	. SCREW, MACHINE:10-32 X 0.50 INCH, HEX - - - * - - -					83385	OBD
-3	134-0067-00			4	. BUTTON, PLUG:GRAY PLASTIC					80009	134-0067-00
-4	213-0334-00			2	. SETSCREW:0.250-28 X 0.750 INCH, SOC STL					56878	OBD
-5	351-0104-00			1	. SLIDE SECT., DWR:PAIR (ATTACHING PARTS)					80009	351-0104-00
-6	212-0023-00			2	. SCREW, MACHINE:8-32 X 0.375 INCH, PNH STL					83385	OBD
-7	210-0458-00			2	. NUT, PLAIN, EXT W:8-32 X 0.344 INCH, STL - - - * - - -					83385	OBD
-8	210-0808-00			2	. EYELET, METALLIC:CENTERING (ATTACHING PARTS FOR EACH)					63743	2515113-3TP-909
-9	211-0507-00			1	. SCREW, MACHINE:6-32 X 0.312 INCH, PNH STL					83385	OBD
-10	210-0457-00			1	. NUT, PLAIN, EXT W:6-32 X 0.312 INCH, STL - - - * - - -					83385	OBD
-11	386-2669-00			1	. SUPPORT, CABINET:REAR (ATTACHING PARTS)					80009	386-2669-00
-12	212-0023-00			4	. SCREW, MACHINE:8-32 X 0.375 INCH, PNH STL					83385	OBD
-13	210-0458-00			2	. NUT, PLAIN, EXT W:8-32 X 0.344 INCH, STL - - - * - - -					83385	OBD
-14	407-1350-00			1	. BRACKET, ANGLE:REAR (ATTACHING PARTS)					80009	407-1350-00
-15	212-0023-00			2	. SCREW, MACHINE:8-32 X 0.375 INCH, PNH STL					83385	OBD
-16	210-0458-00			2	. NUT, PLAIN, EXT W:8-32 X 0.344 INCH, STL - - - * - - -					83385	OBD
-17	211-0517-00			2	. SCREW, MACHINE:6-32 X 1 INCH, PNH, STL					83385	OBD
-18	212-0033-00			4	. SCREW, MACHINE:8-32 X 0.750 INCH, PNH STL					83385	OBD
-19	437-0154-01			1	. CABINET, SCOPE:					80009	437-0154-01
-20	351-0101-00			1	. SLIDE, DWR, EXT:PAIR					80009	351-0101-00
-21	016-0099-00			1	. HDW KIT, ELEK EQ:					80009	016-0099-00



(A)

REV. JUNE 1974

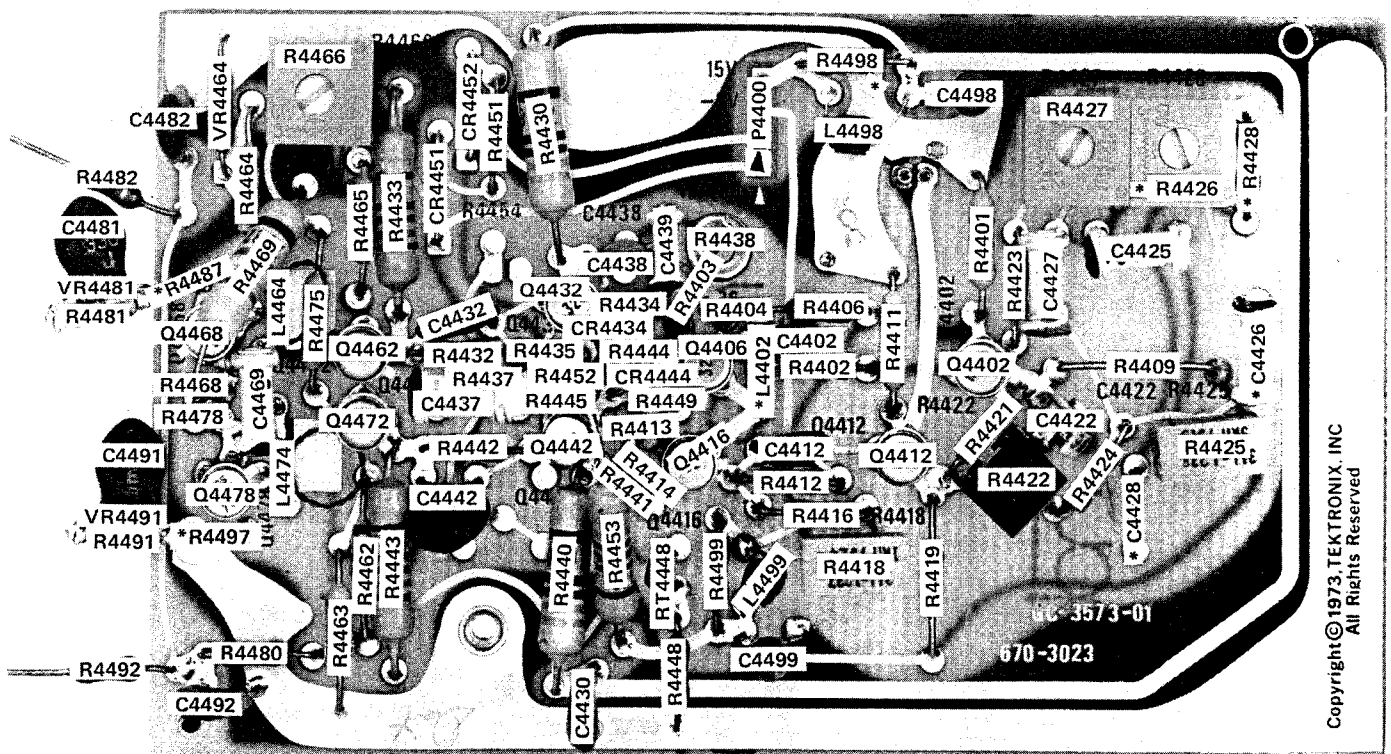

*See Parts List for serial number ranges.

REV. JUNE 1974

Located on back of board
 R4474
 R4431
 R4436
 R4408
 M20,159

Copyright © 1973, TEKTRONIX, INC
 All Rights Reserved

(D)

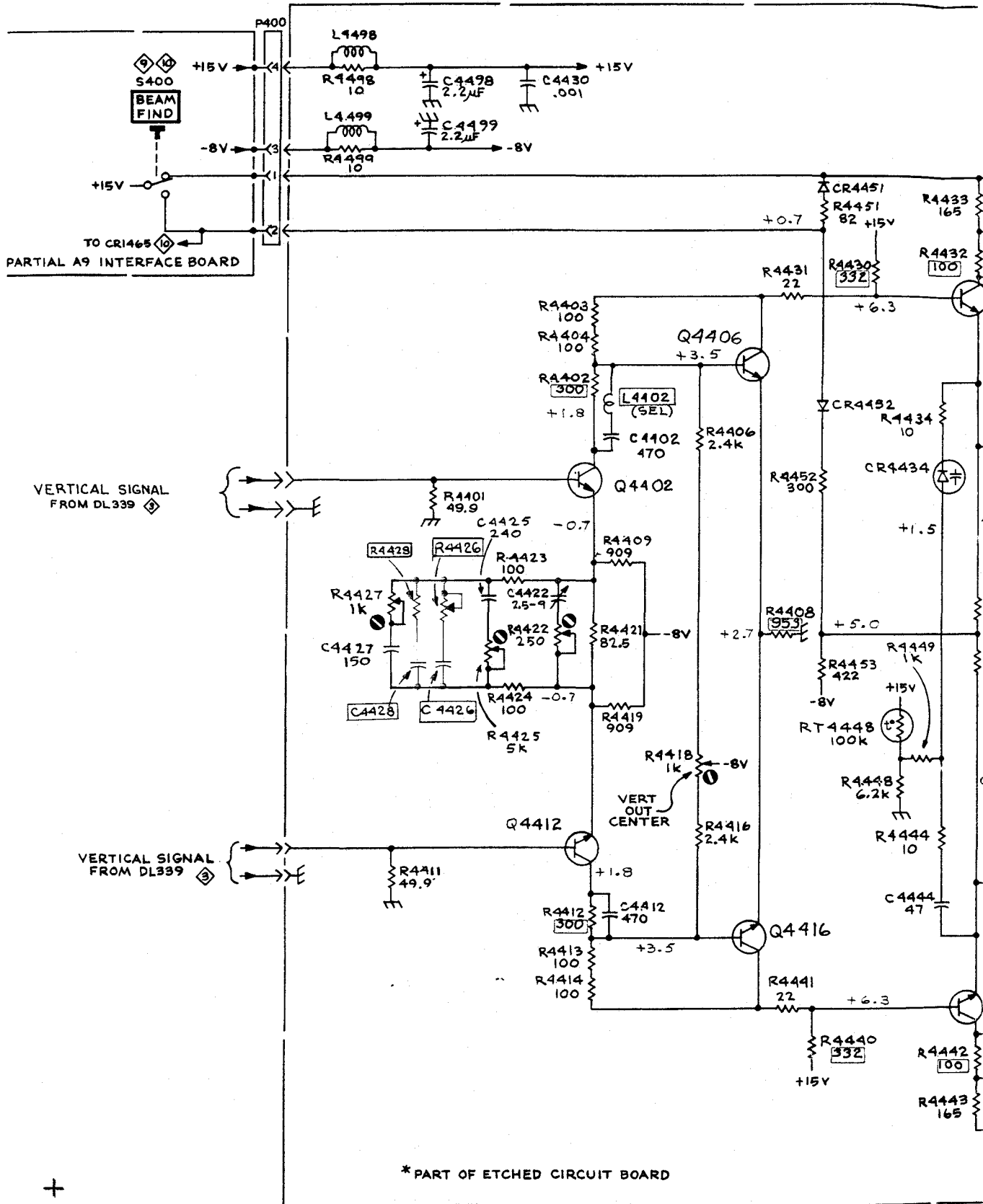

465 OSCILLOSCOPE

(E)

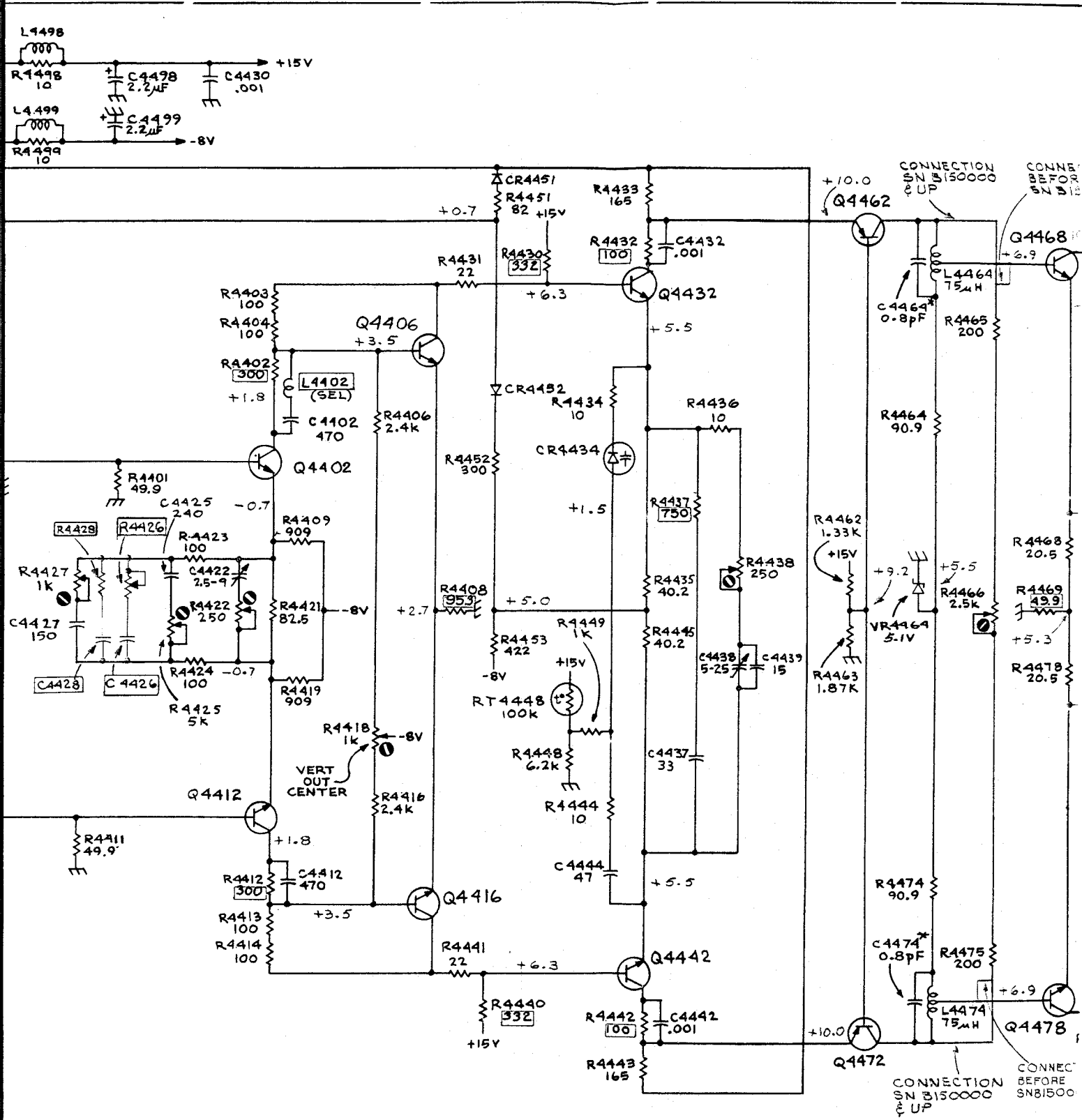

*PART OF ETCHED CIRCUIT BOARD

A5 VERTICAL OUTPUT BOARD

(E)

REV. JUNE 7
VERTICAL OUTPUT
 (B040000 AND UP)
 M 20159

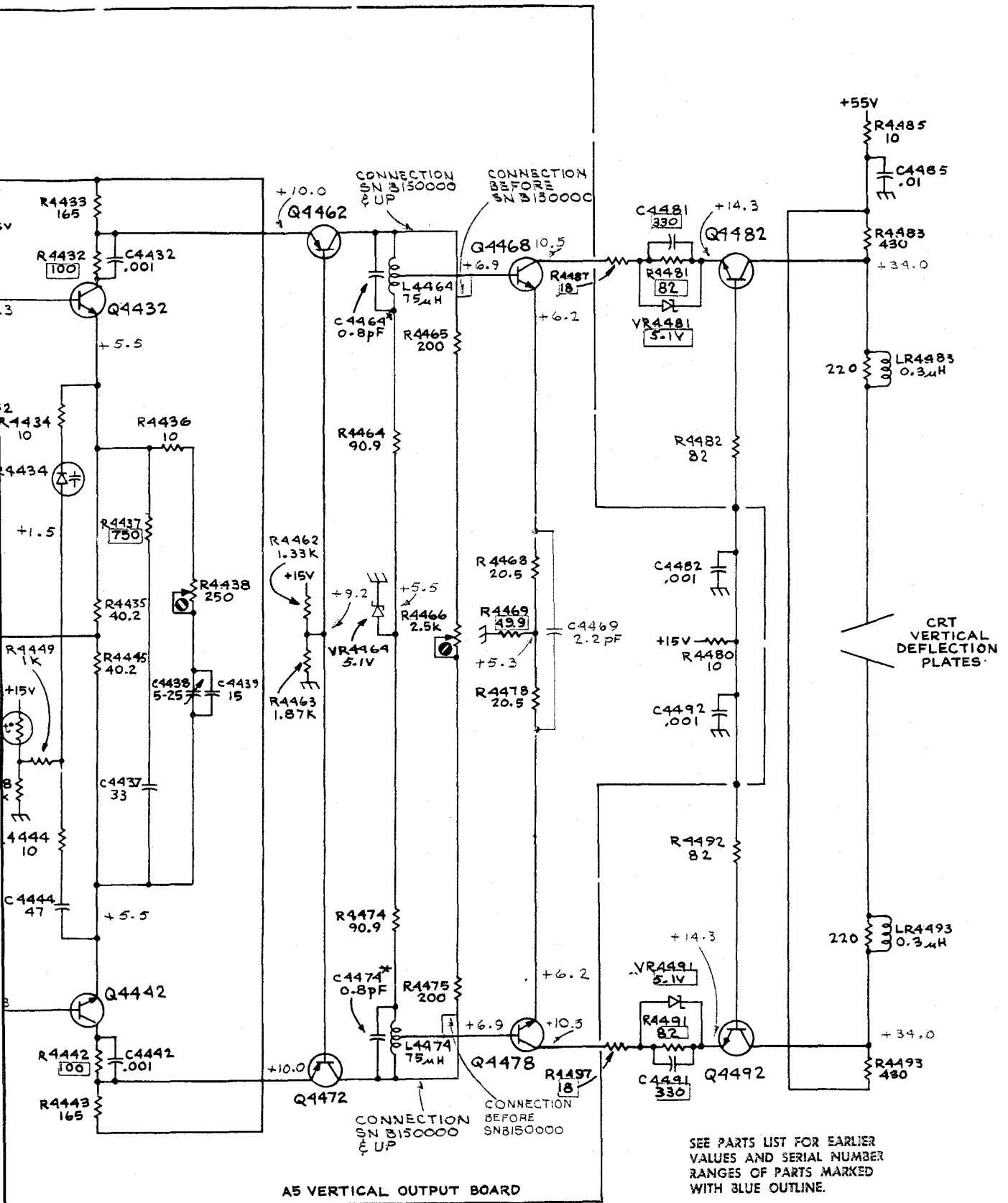

M20159 (670-3023)

REV. JUNE 74
VERTICAL OUTPUT AMPLIFIER 4
 (B040000 AND UP) 670-3023
 M20159

Ⓔ