

INSTRUCTION MANUAL



**TYPE
PLUG-IN**

Tektronix, Inc.

S.W. Millikan Way ● P. O. Box 500 ● Beaverton, Oregon ● Phone MI 4-0161 ● Cables: Tektronix

Tektronix International A.G.

Terrassenweg 1A ● Zug, Switzerland ● PH. 042-49192 ● Cable: Tekintag, Zug Switzerland ● Telex 53.574

070-230



WARRANTY

All Tektronix instruments are warranted against defective materials and workmanship for one year. Tektronix transformers, manufactured in our own plant, are warranted for the life of the instrument.

Any questions with respect to the warranty mentioned above should be taken up with your Tektronix Field Engineer.

Tektronix repair and replacement-part service is geared directly to the field, therefore all requests for repairs and replacement parts should be directed to the Tektronix Field Office or Representative in your area. This procedure will assure you the fastest possible service. Please include the instrument Type and Serial number with all requests for parts or service.

Specifications and price change privileges reserved.

Copyright © 1960 by Tektronix, Inc., Beaverton, Oregon. Printed in the United States of America. All rights reserved. Contents of this publication may not be reproduced in any form without permission of the copyright owner.



CONTENTS

- Section 1 Specifications
- Section 2 Operating Instructions
- Section 3 Circuit Description
- Section 4 Maintenance
- Section 5 Calibration Procedure
- Section 6 Parts List and Schematic

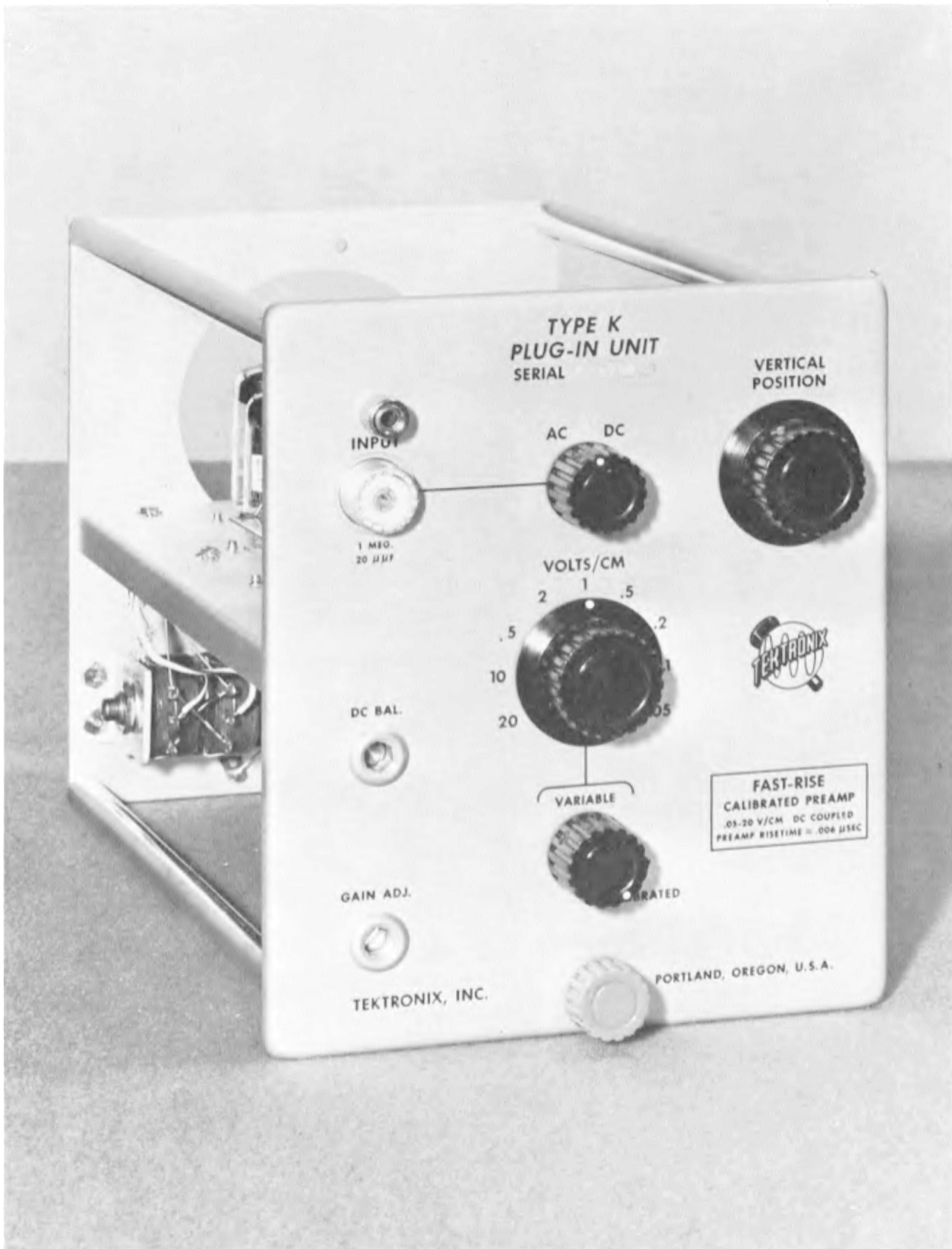

Type K

SPECIFICATIONS

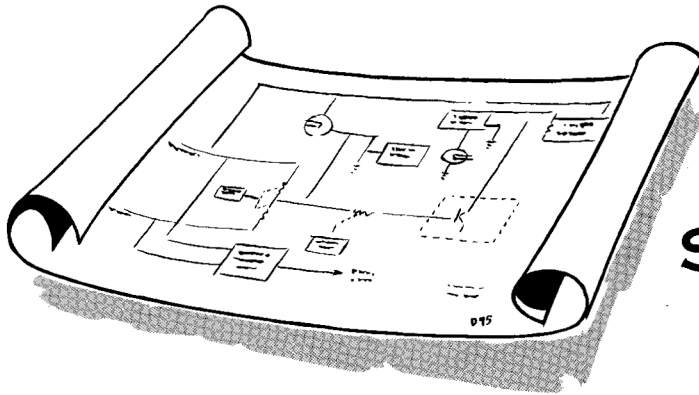

NOTE

At earlier serial number ranges, the Type K was described as Type 53/54K. The designation was later changed to Type K. For purposes of this manual, all serial ranges will be referred to as Type K.

GENERAL DESCRIPTION

The Type K Plug-In Unit is a fast rise calibrated preamp, designed to be used as a preamplifier for Tektronix Type 530-, 540- and 550-Series Oscilloscopes.

TYPE K SPECIFICATIONS

Transient Response

- Preamp Alone—6 nanoseconds.
- With Type 541, 541A, 543, 545, 545A and 555—12 nanoseconds.
- With Type 531, 531A, 533, 535 and 535A—.031 microseconds.
- With Type 551 — .014 microseconds.

Frequency Response

- With Type 541, 541A, 543, 545, 545A and 555.
- Passband-DC to 30 mc, 2 cps to 30 mc ac. Down 3 db $\pm 1/2$ db at 30 mc, 6 db at approximately 41 megacycles, 12 db at approximately 55 megacycles.

- With Type 531, 531A, 533, 535 and 535A.
- Passband—DC to 15 mc.
- With Type 551.
- Passband — DC to 25 mc.
- Deflection Factor—DC to 25 mc.
- Step Attenuator
- Nine positions, calibrated, from .05 v/cm to 20 v/cm, accurate within 3 percent when set on any one step.
- Maximum Allowable Combined dc and peak ac Voltage Input—600 v.
- Input Impedance—1 megohm, 20 $\mu\mu\text{f}$.
- With P410 probe—10 megohms, 7.5 $\mu\mu\text{f}$.
- With P6000 probe—10 megohms, 11.5 $\mu\mu\text{f}$.

Mechanical Specifications

- Construction—Aluminum-alloy chassis.
- Finish—Photo-etched anodized panel.
- Weight—3 $\frac{1}{2}$ pounds.

Accessories

- 2—Instruction Manuals

FUNCTIONS OF CONTROLS AND CONNECTORS

- INPUT UHF coaxial connector to preamp.
- AC, DC Switch to insert or remove coupling capacitor for ac or dc operation.
- VERTICAL POSITION Control to position the oscilloscope trace vertically.
- VOLTS/CM Switch to select accurate, frequency-compensated attenuators which provide the sensitivity indicated, when the VARIABLE control is in the CALIBRATED position.
- VARIABLE Variable gain control over a ratio of about 2 to 1.
- DC BAL. Screwdriver front-panel control to set the dc levels so the trace will not shift vertically when the VARIABLE control is rotated.
- GAIN ADJ. Screwdriver front-panel control adjusts amplifier gain to calibrate VOLTS/CM control.

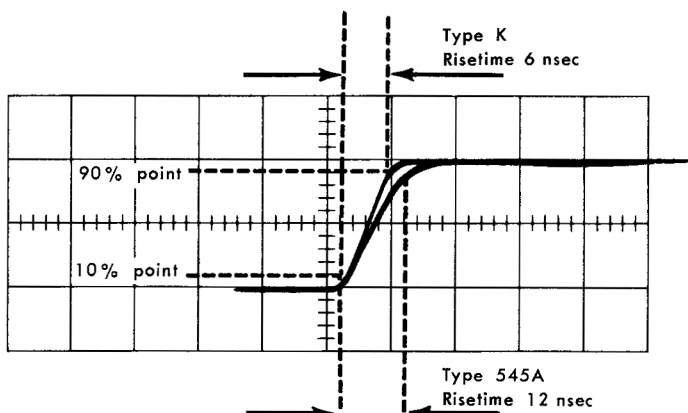
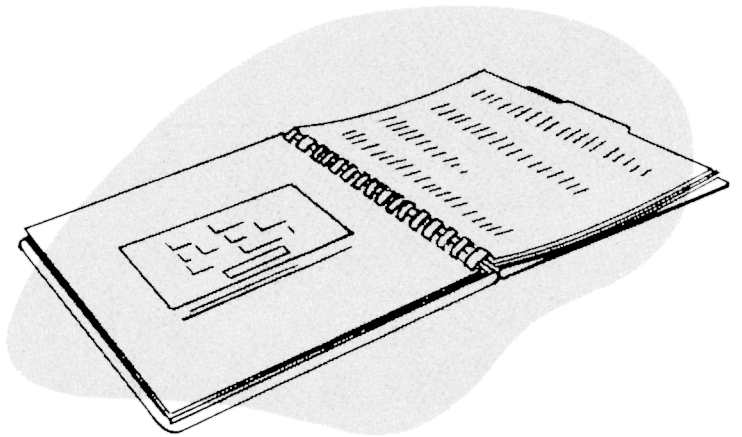

Fig. 1-1. Comparison of risetimes of the Type K Preamp and a Type 545A Oscilloscope.

SECTION 2

OPERATING INSTRUCTIONS



General

The Type K Preamp is designed to operate as the pre-amplifier for a Tektronix 530-Series, 540-Series or 550-Series Oscilloscope. We assume that it will be operated in that manner in the following instructions.

Input Connections

In making connections for signal sources to the INPUT connector of the Type K Preamp, it is important that interconnecting cables be properly terminated to avoid loss of frequency response. Fig. 2-1 shows how a square wave

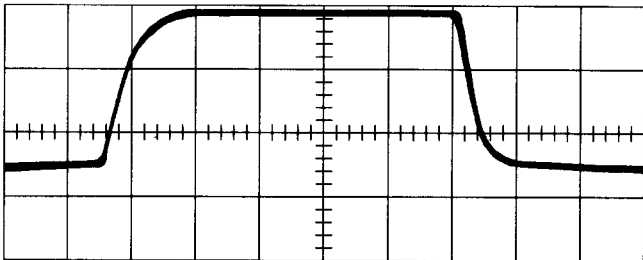

Fig. 2-1. A 450-kc square wave from a Type 105 Square Wave Generator, displayed on a Type 545A Oscilloscope. Interconnecting cable is a 52-ohm unterminated coaxial line.

signal from a Type 105 Square Wave Generator is deteriorated by improper termination. The forward corner of the waveform shows severe rolloff, and the trailing edge of the square-wave is also severely deteriorated. Also noticeable on close observation are the small aberrations on the "rise" and "fall" portions of the waveform produced by standing waves generated along the improperly terminated line. Fig. 2-2 shows the effect of properly terminating the same waveform between the Type 105 and the Type K.

Probe Information

Early Type K Units were furnished with P500-Series or P400-Series probes. P500-Series probes are usable in the range from DC to 10 megacycles. P400-Series probes should be used with 540-Series and 550-Series oscilloscopes where

frequencies in excess of 10 MC are likely to be encountered.

P400-Series probe bodies are $\frac{3}{4}$ -inch in diameter. They are molded of fiberglass-reinforced alkyd and have an internal brass shield. Noses are color-coded to indicate attenuation ratios. Length is $3\frac{3}{4}$ inches without tip. Two Tek-tips were furnished with each probe—a straight tip and freely-rotating hooked tip. The tips increase probe length by about one inch, adding less than $0.5 \mu\mu\text{f}$ to the input capacitance. P400-Series probes have a 42-inch coaxial cable with uhf connector.

The Type P6000 probe may be used with either the 530-Series or 540-Series Oscilloscopes. Be sure to check the adjustment of the probe when you first connect it to the plug-in. Touch the probe tip to the calibrator output connector and display several cycles of the calibrator waveform. If the top and bottom of the displayed waveform is not flat, loosen the locking ring by turning it in a counterclockwise direction. Rotate the barrel of the probe as necessary to compensate the probe. Tighten the locking ring carefully after compensating the probe, being careful not to disturb the probe adjustment.

P400-Series and P500-Series Probe Adjustment

An adjustable capacitor compensates for slight variations in input capacitance from one instrument to another. This capacitor is located in the probe body in the P405, P410, P420, and in the termination block at the instrument end of the cable in the P450, P450-L and P4100. It takes only a few seconds to check this adjustment, and it is a good practice to make this check each time the probe is to be used. Simply touch the probe to the oscilloscope calibrator-output

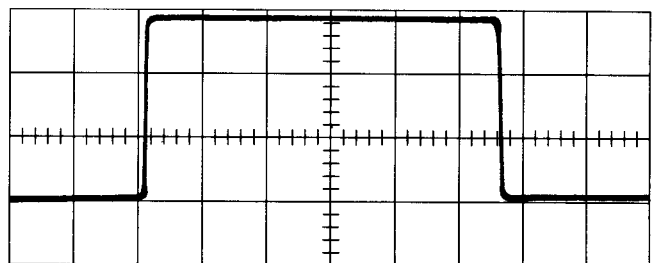

Fig. 2-2. A 450-kc square wave from Type 105 Type K—545A combination, connected by 52-ohm cable, terminated at both ends.

PROBE CHARACTERISTICS

Probe	Color Code	Attenuation Ratio	INPUT IMPEDANCE			Insertion Loss at 30 mc (db)	Voltage Rating (Peak-to-Peak)
			Resistance (Megohms)	Typical Capacitance			
				Minimum*	Maximum*		
P405	Green	5:1	5	12 $\mu\mu\text{f}$	19 $\mu\mu\text{f}$	1 to 2	600
P410	Brown	10:1	10	8 $\mu\mu\text{f}$	11 $\mu\mu\text{f}$	1	600
P420	Red	20:1	10	5.5 $\mu\mu\text{f}$	7 $\mu\mu\text{f}$	1	600
P450	Clear-Green	50:1	10	3.5 $\mu\mu\text{f}$	3.5 $\mu\mu\text{f}$	1	1000
P450L †	Clear-Green	50:1	10	2.5 $\mu\mu\text{f}$		1	1000
P4100	Clear	100:1	10	2.5 $\mu\mu\text{f}$	2.5 $\mu\mu\text{f}$	1	1000
P6000	Black	10:1	10	11.5 $\mu\mu\text{f}$	14.5 $\mu\mu\text{f}$	1.2	600
P6017	None	10:1	10	14.0 $\mu\mu\text{f}$	14.0 $\mu\mu\text{f}$	1	600

* When connected to instruments having 20 $\mu\mu\text{f}$ input capacitance.
 ** When connected to instruments having 50 $\mu\mu\text{f}$ input capacitance.
 † Will not adjust to instrument having over 25 $\mu\mu\text{f}$ input capacitance.

terminal and observe the calibrator waveform on the screen. If necessary, adjust the trimmer for a flat top on the calibrator square wave. For critical adjustment of the P400, a faster-rising square wave, such as the output of the Tektronix Type 104A or Type 105 should be used.

Probe Preventive Maintenance

Regular inspection of the probe nose and cable fastening screws will help prevent possible mechanical damage due to twisting. A small nylon screw holds the nose in place, and an allen setscrew grips the cable firmly. Tighten these screws if they work loose.

Probe Repair

To disassemble P400- and P500-Series probes, remove the nylon screw and loosen the allen setscrew. Slide the probe body back over the cable. Examine the layout carefully before proceeding. The center conductor of the cable is extremely fragile; be careful not to break it when removing a probe part. Replacement parts can be obtained through field offices or directly from the factory. When resoldering, it is important to get a good connection between the probe resistor and the center conductor of the cable. Reassemble the probe and tighten the screws.

Coupling

It is sometimes unnecessary or undesirable to display the dc level of the waveform. In the AC position of the AC-DC switch, a capacitor in series with the input blocks the dc component of the waveform so that only the ac component is displayed.

Deflection Sensitivity

The VOLTS/CM switch inserts frequency-compensated attenuators ahead of the amplifier. The VARIABLE control

provides continuous adjustment of the deflection sensitivity between the values indicated by the VOLTS/CM switch.

NOTE

The VARIABLE control must be clockwise to CALIBRATED position for the sensitivity to be as indicated by the VOLTS/CM control.

Gain Adjustment

Aging of tubes will affect the gain of the plug-in unit. After the plug-in unit has been in use for a period of time the gain adjustment should be checked. Display a calibrator waveform of 0.2 volts peak to peak with the VOLTS/CM switch in the .05 position. Adjust the GAIN ADJ. control until the displayed waveform is four graticule divisions in amplitude. Be sure the VARIABLE control is turned clockwise to the CALIBRATED position before making this adjustment.

DC Balance Adjustment

The need for adjustment of the DC BAL control is indicated by a shift in the position of the trace as the VARIABLE control is rotated. This is caused by tube aging and the resulting shift in operating potentials. This adjustment should be made after the GAIN ADJ. control is set. Rotate the VARIABLE control back and forth and adjust the DC BAL. control until the trace position is no longer affected by rotation of the VARIABLE control.

Positioning Adjustment

The VERT POS RANGE control balances the dc output level so the full range of the front-panel positioning control can be utilized. The VERT POS RANGE control is located at the left to the rear of the plug-in unit and is accessible when the left side panel of the oscilloscope is removed. Center the VERTICAL POSITION control. Adjust the VERT POS RANGE control to center the trace on the screen.

SECTION 3

CIRCUIT DESCRIPTION

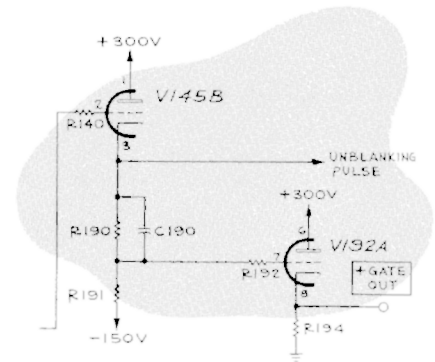

General

The Type K Preamp has a maximum sensitivity of .05 volts per centimeter and a rise time of approximately .006 microseconds. The circuit consists of one stage of amplification preceded and followed by cathode followers.

Input Attenuators

The VOLTS/CM switch inserts frequency-compensated attenuators into the input circuit. When properly adjusted, the input resistance and capacitance of the unit remains unchanged as the attenuators are inserted. The AC-DC switch inserts or removes a blocking capacitor in the input circuit. In serial numbers 101-352, C5611 compensates for the high-frequency characteristics of the larger capacitor.

Input Cathode Follower

The input cathode follower, V5701, reduces to a minimum the input capacitance presented by the amplifier and isolates the input circuits from changes in capacitance as the VARIABLE gain control is varied. R5661 is a current-limiting resistor to limit the grid current in the event an excess voltage is applied to the input.

The DC BAL. control, R6731, (R5511 serial numbers 101-352) provides a means of setting the two cathodes of the amplifier stage to the same dc level so that there will be no shift of the trace as the VARIABLE control is rotated. In serial numbers 101-352 Cathode Follower V5701A reduces amplifier drift caused by V5701B since the two cathode followers tend to drift in the same direction.

Amplifier

The amplifier stage V6111 and V6101, is a common-

cathode phase-splitter amplifier. Coils L6101A and L6101B (L6201 and L6211 serial numbers 101-352) form peaking networks in the plate circuits. R6261 provides the current for the amplifier plates, and a tap to the heater string provides a low impedance at this point.

The VARIABLE VOLTS/CM control, R6101, varies the gain over a 2-to-1 ratio by varying the degeneration in the cathode circuit. The GAIN ADJ. control sets the gain to agree with the front-panel calibration when the VARIABLE control is completely clockwise to the CALIBRATED position.

Vertical positioning is produced by two dual potentiometers connected to the plates of the amplifier so that current through one plate load is increased when the potentiometer is adjusted to reduce the current through the other plate load. The VERT. POS. RANGE control has about twice the range of the VERTICAL POSITION control and allows the positioning to be set so the trace is centered when the VERTICAL POSITION control is centered.

Output Cathode Follower

Two sets of cathode followers follow the amplifier stage in order to provide minimum capacitance to the amplifier and drive the capacitance of the interconnecting plug and main-amplifier input circuit. The second cathode follower is modified by the addition of resistors in the plate circuits and by capacitors cross-connected from each plate to the opposite cathode, to improve the high-frequency balance of the unit.

H.F. Peaking (S/N 353 and up)

The H.F. PEAKING control, R6541, varies the current in the output cathode followers. This changes the impedance at the cathodes and changes the effect of the series peaking coils, L6601 and L6611, tied to these cathodes.

MAINTENANCE

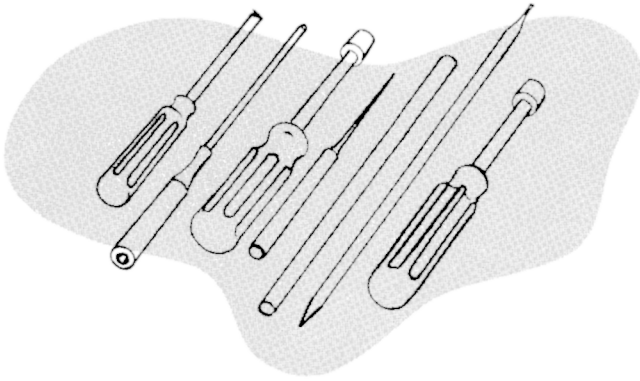

Replacement of Components

Tektronix will supply replacement components at current net prices. However, since most of the components are standard electronic and radio parts we suggest you get them from your local dealer if you can. Be sure to consult your instruction manual first to see what tolerances are required.

We specially select some of the components, whose values must fall within prescribed limits, by sorting through our regular stocks. The components so selected will have standard RETMA color-code marks showing the values and tolerances of the stock they were selected from, but they will not in general be replaceable from dealer stocks.

Such selected parts, as well as the parts we manufacture at Tektronix, are identified in the parts lists either by notes or by our own stock numbers. Order these parts from the Tektronix factory in Beaverton, Oregon.

Parts-Ordering Information

You will find a serial number on the frontispiece of this manual. This is the serial number of the instrument the manual was prepared for. Be sure the manual number matches the number of the instrument when you order parts.

A Tektronix instruction manual usually contains hand-made changes to diagrams and parts list, and sometimes text. These changes are in general only appropriate to the instrument the manual was prepared for, the instrument whose serial number appears on the manual frontispiece. The hand-made changes show changes to the instrument that have been made after the printing of the manual.

We make some of the instrument changes during the factory test procedure. Our technicians hand-tailor the circuits, if it seems appropriate, to provide the widest possible latitude of operation. Other changes are made to include the latest circuit improvements as they are developed in our engineering department, or when improved components become available. In any event, the changes are to your benefit. We have tried to give you the best instrument we can.

Soldering and Ceramic Strips

Many of the components in your Tektronix instrument are mounted on ceramic terminal strips. The notches in these strips are lined with a silver alloy. Repeated use of excessive heat, or use of ordinary tin-lead solder will break down the

silver-to-ceramic bond. Occasional use of tin-lead solder will not break the bond if excessive heat is not applied.

If you are responsible for the maintenance of a large number of Tektronix instruments, or if you contemplate frequent parts changes, we recommend that you keep on hand a stock of solder containing about 3% silver. This type of solder is used frequently in printed circuitry and should be readily available from radio-supply houses. If you prefer, you can order the solder directly from Tektronix in one-pound rolls. Order by Tektronix part number 251-514.

Because of the shape of the terminals on the ceramic strips it is advisable to use a wedge-shaped tip on your soldering iron when you are installing or removing parts from the strips. Fig. 4-1 will show you the correct shape for the tip of the soldering iron. Be sure and file smooth all surfaces of the iron which will be tinned. This prevents solder from building up on rough spots where it will quickly oxidize.

When removing or replacing components mounted on the ceramic strips you will find that satisfactory results are obtained if you proceed in the manner outlined below.

1. Use a soldering iron of about 75-watt rating.
2. Prepare the tip of the iron as shown in Fig. 4-1.
3. Tin only the first 1/16 to 1/8 inch of the tip. For soldering to ceramic terminal strips tin the iron with solder containing about 3% silver.

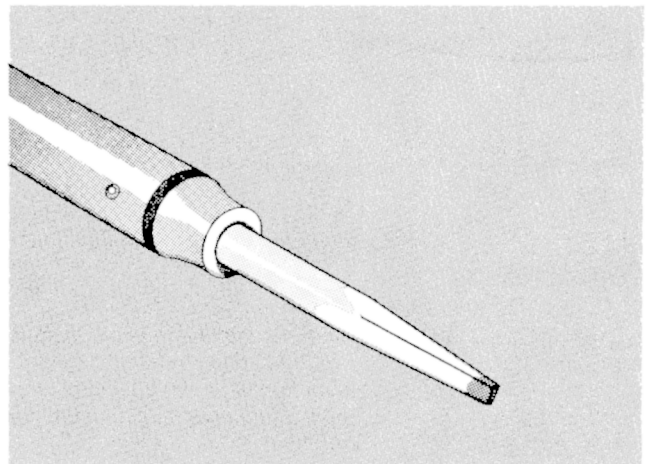

Fig. 4-1. Soldering iron tip properly shaped and tinned.

Maintenance — Type K

4. Apply one corner of the tip to the notch where you wish to solder (see Fig. 4-2).
5. Apply only enough heat to make the solder flow freely.
6. Do not attempt to fill the notch on the strip with solder; instead, apply only enough solder to cover the wires adequately, and to form a slight fillet on the wire as shown in Fig. 4-3.

In soldering to metal terminals (for example, pins on a tube socket) a slightly different technique should be employed. Prepare the iron as outlined above, but tin with ordinary tin-lead solder. Apply the iron to the part to be soldered as shown in Fig. 4-4. Use only enough heat to allow the solder to flow freely along the wire so that a slight fillet will be formed as shown in Fig. 4-3.

General Soldering Considerations

When replacing wires in terminal slots clip the ends neatly as close to the solder joint as possible. In clipping ends or wires take care the end removed does not fly across the room as it is clipped.

Occasionally you will wish to hold a bare wire in place as it is being soldered. A handy device for this purpose is a short length of wooden dowel, with one end shaped as shown in Fig 4-5. In soldering to terminal pins mounted in plastic rods it is necessary to use some form of "heat sink" to avoid melting the plastic. A pair of long-nosed pliers (see Fig. 4-6) makes a convenient tool for this purpose.

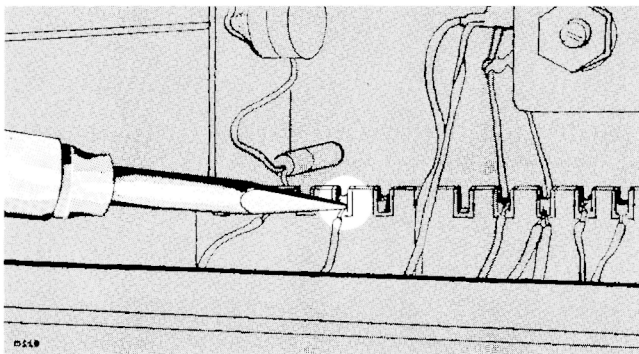

Fig. 4-2. Correct method of applying heat in soldering to a ceramic strip.

Ceramic Strips

Two distinct types of ceramic strips have been used in Tektronix instruments. The earlier type mounted on the chassis by means of #4-40 bolts and nuts. The later type is mounted with snap-in, plastic fittings. Both styles are shown in Fig. 4-7.

To replace ceramic strips which bolt to the chassis, screw a #4-40 nut onto each mounting bolt, positioning the bolt so that the distance between the bottom of the bolt and

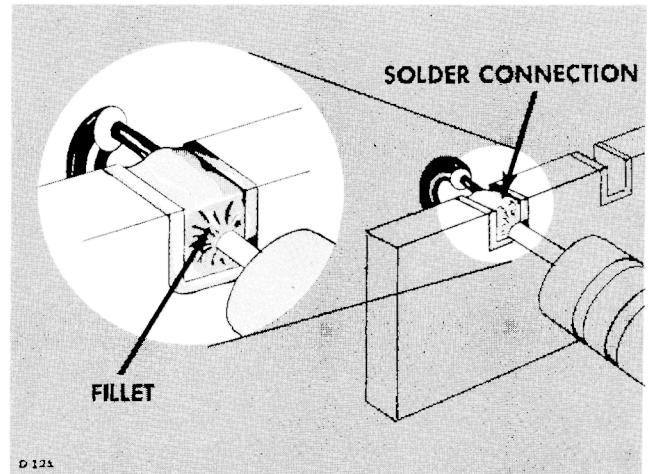

Fig. 4-3. A slight fillet of solder is formed around the wire when heat is applied correctly.

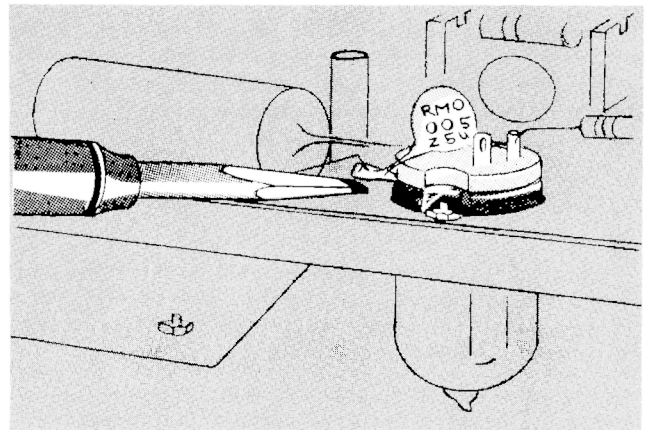

Fig. 4-4. Soldering to a terminal. Note the slight fillet of solder-exaggerated for clarity-formed around the wire.

the bottom of the ceramic strips equals the height at which you wish to mount the strip above the chassis. Secure the nuts to the bolts with a drop of red glyptal. Insert the bolts through the holes in the chassis where the original strip was mounted, placing a #4-40 lockwasher between each nut and the chassis. Place a second set of #4-40 lockwashers on the protruding ends of the bolts, and fasten them firmly with another set #4-40 nuts. Place a drop of red glyptal over each of the second set of nuts after fastening.

Mounting Later Ceramic Strips

To replace strips which mount with snap-in plastic fittings, first remove the original fittings from the chassis. Assemble

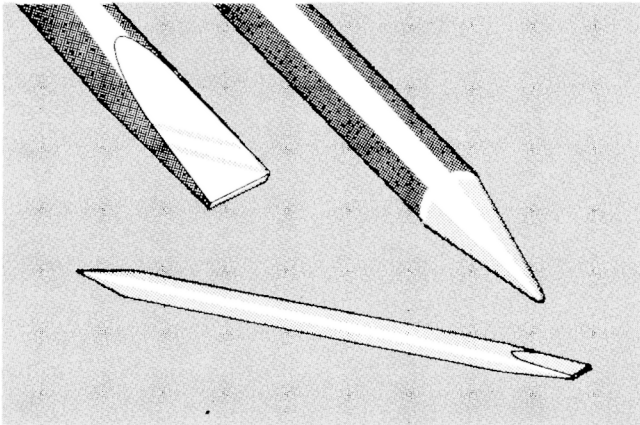

Fig. 4-5. A soldering aid constructed from a 1/4 inch wooden dowel.

the mounting post on the ceramic strip. Insert the nylon collar into the mounting holes in the chassis. Carefully force the mounting post into the nylon collars. Snip off the portion of the mounting post which protrudes below the nylon collar on the reverse side of the chassis.

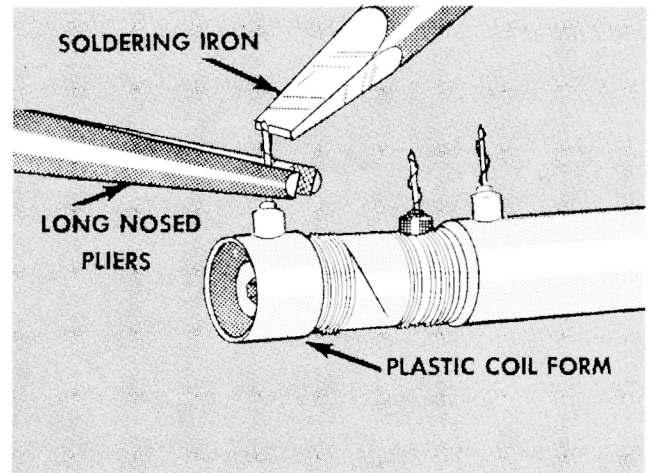

Fig. 4-6. Soldering to a terminal mounted in plastic. Note the use of the long-nosed pliers between the iron and the coil form to absorb the heat.

NOTE

Considerable force may be necessary to push the mounting rods into the nylon collars. Be sure that you apply this force to the upper ends of the mounting rods rather than to the ceramic strip.

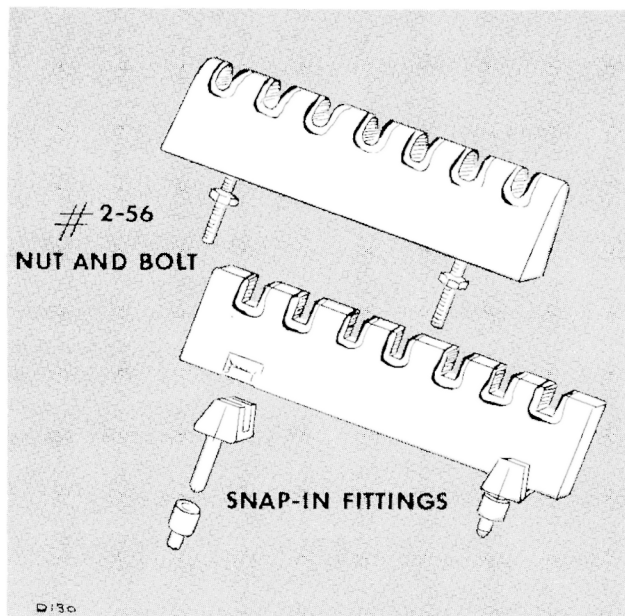
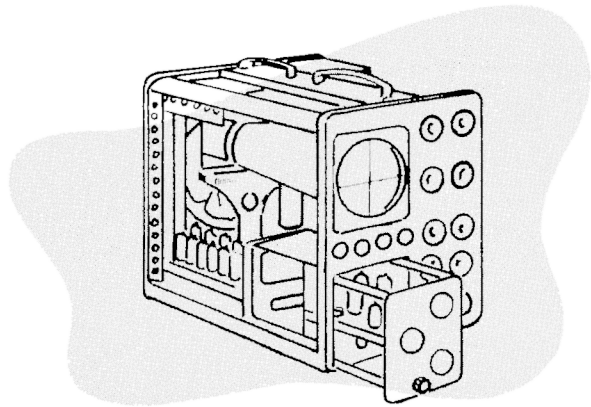

Fig. 4-7. Two types of ceramic strip mountings.

SECTION 5

CALIBRATION PROCEDURE



General

The following outline is based on the procedure used in our test department at the factory. Ordinarily, adjustment in the field will consist of merely touching up some of the potentiometer adjustments, most of which are accessible when the unit is plugged into an oscilloscope. However, to adjust the attenuators the unit must be partially out of the oscilloscope. For this reason we make the Type EP53 Plug-in Extension which permits the unit to be operated partially out of the oscilloscope.

Plug the unit into an oscilloscope and turn the power on. Wait about five minutes for the initial warm-up drift to cease. Free run the oscilloscope sweep at some convenient rate so a trace is visible on the crt face.

DC Balance

Rotate the VARIABLE VOLTS/CM control back and forth while watching the trace for a vertical shift. Slowly turn the DC BAL. adjustment until the trace remains steady as the variable attenuator is rotated.

Gain Adjustment

Connect a .2-volt signal from the oscilloscope calibrator to the INPUT connector. Set the VOLTS/CM switch to .05 and turn the VARIABLE control clockwise to the CALIBRATED position. Adjust the GAIN ADJ. potentiometer to obtain four centimeters of deflection. The attenuator uses 1% tolerance resistors, so this one adjustment should calibrate all ranges.

Positioning Adjustment

Center the VERTICAL POSITION control and adjust the VERT. POS. RANGE control until the trace is centered vertically.

Attenuator Adjustments

For best results, the attenuator adjustments should be made with a square-wave generator having a short rise time, such as the Tektronix Type 105. An approximate ad-

justment can be made by using the calibrator waveform, but it is easy to overcompensate the attenuator when using this waveform because of its long risetime.

There is an input capacitance adjustment in each position of the VOLTS/CM switch. All Type K Plug-in Units are adjusted to have an input capacitance of $20\mu\mu\text{f}$. To obtain this value of input capacitance, a probe can first be standardized by adjusting it to a unit known to be in adjustment. This standardized probe can then be used to adjust the input capacitance of the unit to be adjusted. Another method of obtaining the standard input capacitance is to use a Tektronix Type 130 L,C Meter to set the input capacitance in the .05 position of the VOLTS/CM switch. Then adjust the probe in this position to standardize the probe. The input capacitance measurement must be made with the oscilloscope turned on.

1. Input Capacitance Adjustment

The input capacitance of the preamp in the unattenuated position is adjusted first.

- Connect the standardized probe to the INPUT connector.
- Connect the output of the square-wave generator to the probe.
- Set the VOLTS/CM switch to .05.
- Set the square-wave generator to 1 kc and view five or six cycles on the screen.
- If necessary, adjust C5671 for a flat top on the square wave.

2. Attenuator Compensation

The attenuator is compensated to make the ac attenuation equal to the dc attenuation.

- Remove the probe and connect the square-wave generator to the INPUT connector.
- Adjust each capacitor in the following table for a square corner on the square wave in the positions indicated.

VOLTS/CM	CAPACITOR
.1	C5061
.2	C5111
.5	C5161
1	C5211
2	C5261
5	C5311
10	C5361
20	C5911

3. Attenuator Input Capacitance

The input capacitance of the attenuators is adjusted to match the standardized probe in all positions.

- a. Reconnect the standardized probe to the INPUT connector.
- b. Connect the output of the square-wave generator to the probe.
- c. Adjust the capacitors listed in the following table for a flat top on the square wave.

VOLTS/CM	CAPACITOR
.05	C5671
.1	C5051
.2	C5101
.5	C5151

1	C5201
2	C5251
5	C5301
10	C5351
20	C5401

H.F. Peaking Adjustment (SN/353 up)

For best results this adjustment should be made with a pulser having a risetime of five millimicroseconds or less. Plug the Type K Plug-In Unit into a 540-Series Oscilloscope which has its bottom panel removed. The oscilloscope should be in good adjustment. Observe a pulse from the pulser using a sweep speed of .02 μ sec/cm. Set the VOLTS/CM controls to .05. Adjust the H. F. Peaking control to obtain a square corner with no overshoot on the waveform.

Calibration Procedure — Type K

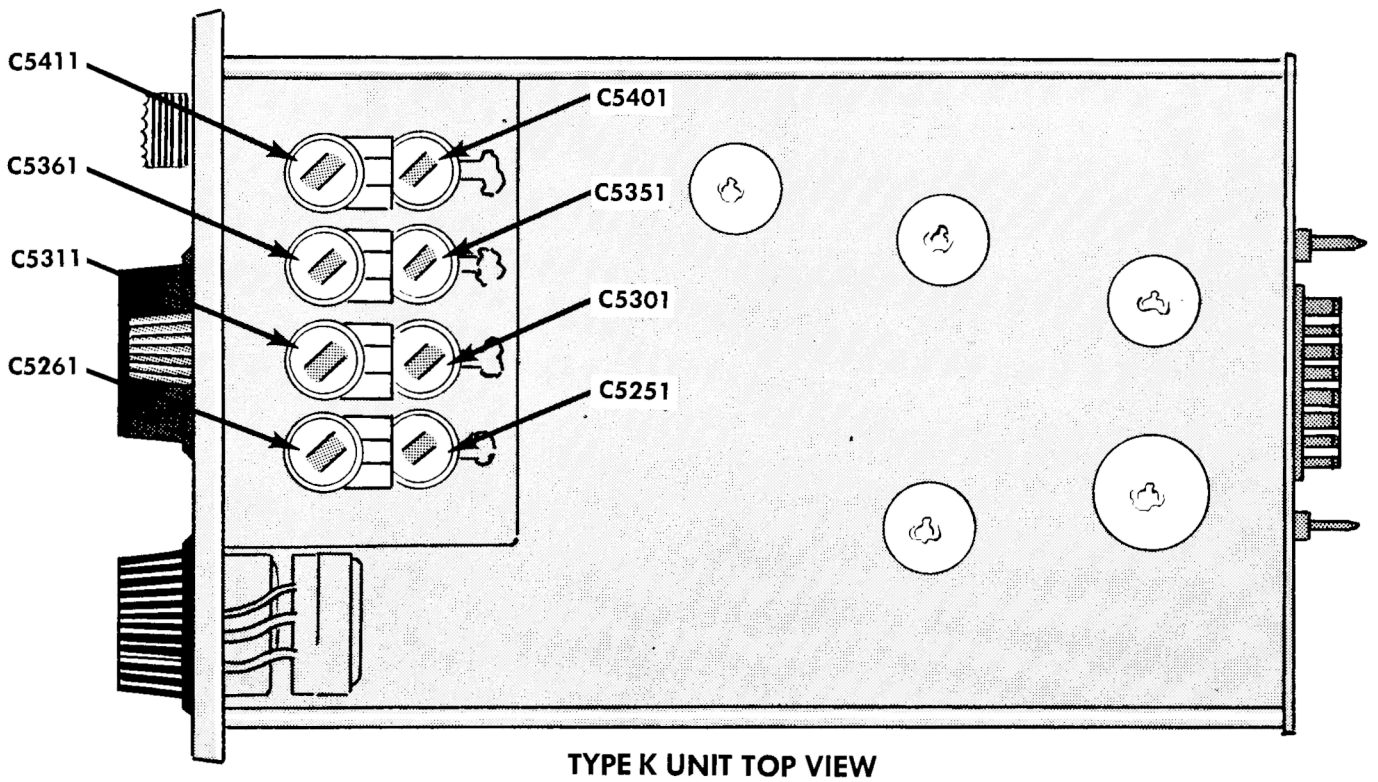
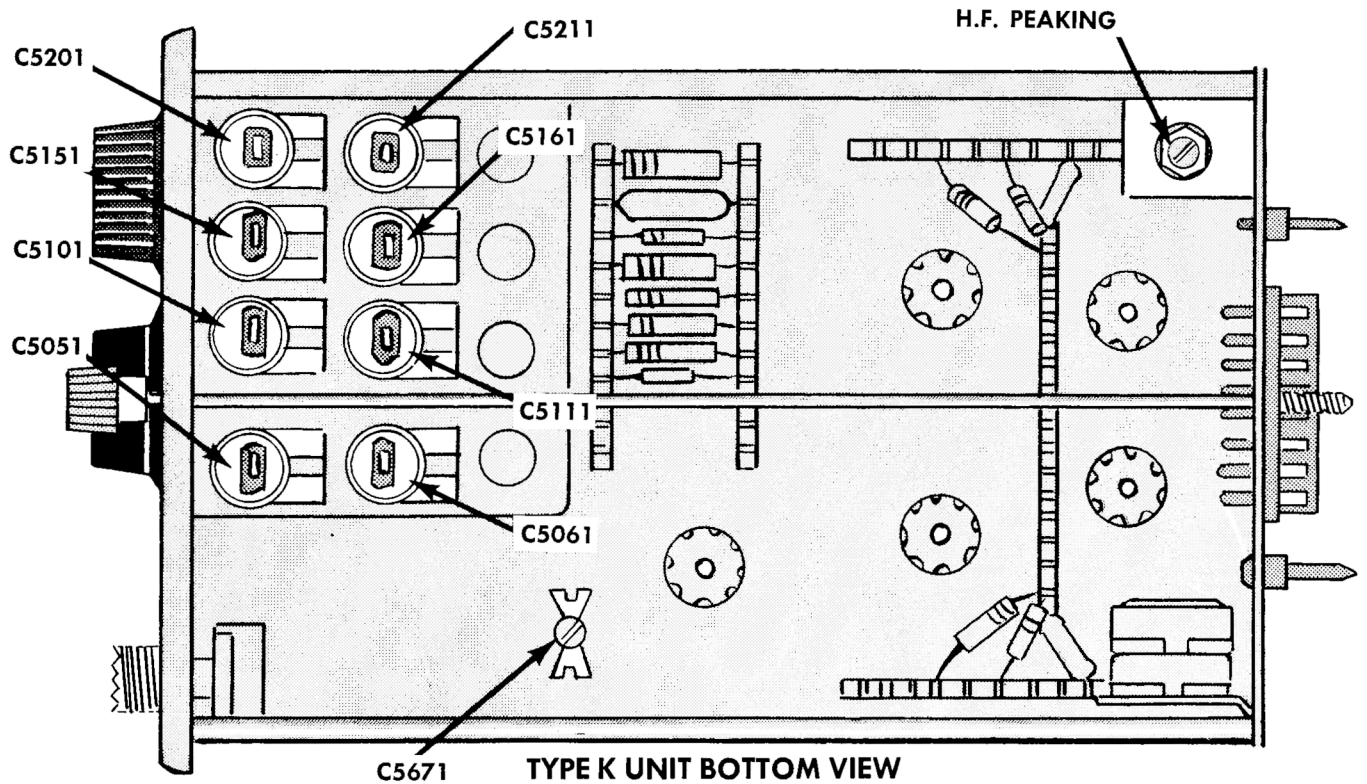
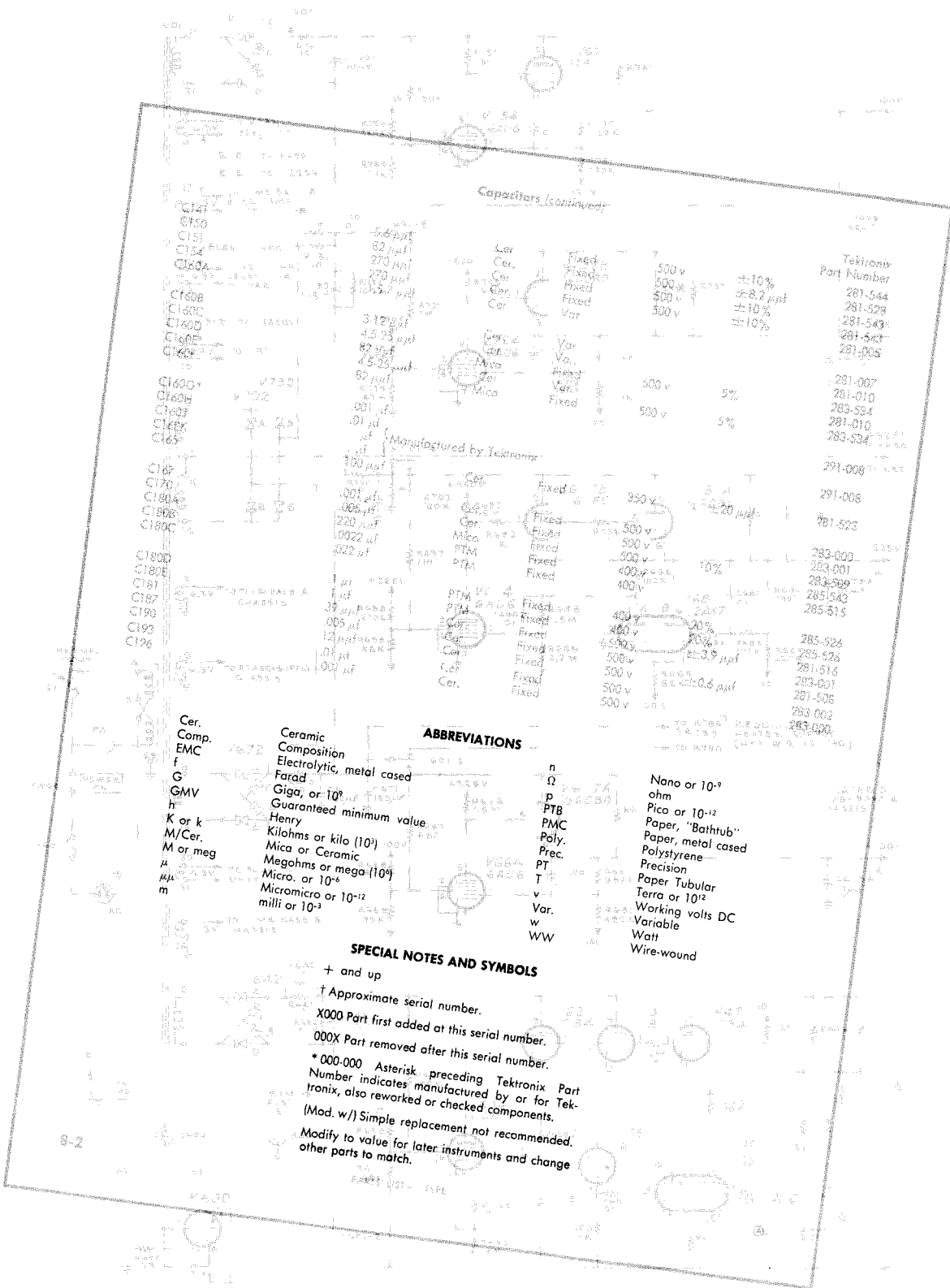

Fig. 5-1. Type K Unit, Top and Bottom Views.



PARTS LIST *and* DIAGRAMS



- ABBREVIATIONS**
- Cer. Ceramic
 - Comp. Composition
 - EMC Electrolytic, metal cased
 - f Farad
 - G Giga, or 10^9
 - h Guaranteed minimum value
 - K or k Henry
 - M/Cer. Kilohms or kilo (10^3)
 - M or meg Mica or Ceramic
 - μ Megohms or mega (10^6)
 - m Micro, or 10^{-6}
 - mm Micromicro or 10^{-12}
 - n milli or 10^{-3}
 - Ω ohm
 - p Pico or 10^{-12}
 - PTB Paper, "Bathtub"
 - PMC Paper, metal cased
 - Poly. Polystyrene
 - Prec. Precision
 - PT Paper Tubular
 - T Terra or 10^{12}
 - v Working volts DC
 - Var. Variable
 - w Watt
 - WW Wire-wound

- SPECIAL NOTES AND SYMBOLS**
- + and up
 - † Approximate serial number.
 - X000 Part first added at this serial number.
 - 000X Part removed after this serial number.
 - * 000-000 Asterisk preceding Tektronix Part Number indicates manufactured by or for Tektronix, also reworked or checked components.
 - (Mod. w/) Simple replacement not recommended.
 - Modify to value for later instruments and change other parts to match.



MANUFACTURERS OF CATHODE-RAY OSCILLOSCOPES

HOW TO ORDER PARTS

Replacement parts are available through your local Tektronix Field Office.

Improvements in Tektronix instruments are incorporated as soon as available. Therefore, when ordering a replacement part it is important to supply the part number including any suffix, instrument type, serial number, plus a modification number where applicable.

If the part you have ordered has been improved or replaced, your local Field Office will contact you if there is a change in part number.

PARTS LIST

Capacitors

Values fixed unless marked Variable.

Tolerance $\pm 20\%$ unless otherwise indicated.

						Tektronix Part Number
C5001	X353-2050	150 $\mu\mu\text{f}$	Cer.		500 v	281-524
	2051-6025	82 $\mu\mu\text{f}$	Cer.		500 v	281-528
	6026-6650	100 $\mu\mu\text{f}$	Cer.		500 v	Use 281-523
	6651-up	100 $\mu\mu\text{f}$	Cer.		350 v	281-523
C5051		1.5-7 $\mu\mu\text{f}$	Cer.	Var.	500 v	281-005
C5061		3-12 $\mu\mu\text{f}$	Cer.	Var.	500 v	281-007
C5101		1.5-7 $\mu\mu\text{f}$	Cer.	Var.	500 v	281-005
C5111		1.5-7 $\mu\mu\text{f}$	Cer.	Var.	500 v	281-005
C5121		4.7 $\mu\mu\text{f}$	Cer.		500 v	$\pm 1.0 \mu\mu\text{f}$ 281-501
C5151		1.5-7 $\mu\mu\text{f}$	Cer.	Var.	500 v	281-005
C5161		1.5-7 $\mu\mu\text{f}$	Cer.	Var.	500 v	281-005
C5171		22 $\mu\mu\text{f}$	Cer.		500 v	10% 281-511
C5201		1.5-7 $\mu\mu\text{f}$	Cer.	Var.	500 v	281-005
C5211		1.5-7 $\mu\mu\text{f}$	Cer.	Var.	500 v	281-005
C5221		47 $\mu\mu\text{f}$	Cer.		500 v	10% 281-519
C5251		1.5-7 $\mu\mu\text{f}$	Cer.	Var.	500 v	281-005
C5261		1.5-7 $\mu\mu\text{f}$	Cer.	Var.	500 v	281-005
C5271		100 $\mu\mu\text{f}$	Cer.		500 v	10% 281-530
C5301		1.5-7 $\mu\mu\text{f}$	Cer.	Var.	500 v	281-005
C5311		1.5-7 $\mu\mu\text{f}$	Cer.	Var.	500 v	281-005
C5321		250 $\mu\mu\text{f}$	Mica.		500 v	10% 283-539
C5351		1.5-7 $\mu\mu\text{f}$	Cer.	Var.	500 v	281-005
C5361		1.5-7 $\mu\mu\text{f}$	Cer.	Var.	500 v	281-005
C5371		500 $\mu\mu\text{f}$	Mica		500 v	10% 283-541
C5401		1.5-7 $\mu\mu\text{f}$	Cer.	Var.	500 v	281-005
C5411		1.5-7 $\mu\mu\text{f}$	Cer.	Var.	500 v	281-005
C5421		750 $\mu\mu\text{f}$	Mica		500 v	10% 283-540
C5521	101-352X	.001 μf	Cer.		500 v	GMV 283-000
C5601	101-10899	.1 μf	PT		600 v	285-547
	10900-up	.1 μf	PTM		600 v	Use *285-603
C5611	101-707X	.001 μf	Cer.		500 v	GMV 283-000
C5661		.005 μf	Cer.		500 v	GMV 283-001
C5671		.5-5 $\mu\mu\text{f}$	Poly	Var.	500 v	281-001
C5701	X353-up	.005 μf	Cer.		500 v	GMV 283-001
C5721	101-352X	.001 μf	Cer.		500 v	GMV 283-000
C5741	101-352X	.001 μf	Cer.		500 v	GMV 283-000
C6111	X353-1122	.001 μf	Cer.		500 v	GMV Use 283-001
	1123-up	.005 μf	Cer.		500 v	GMV 283-001
C6221	X353-up	.047 μf	PTM		400 v	285-519
C6261	101-352X	.005 μf	Cer.		500 v	GMV 283-001

Capacitors (continued)

						Tektronix Part Number
C6601	X110-up	.001 μ f	Cer.	500 v	GMV	283-000
C6611	X110-up	.001 μ f	Cer.	500 v	GMV	283-000
C6701	101-352	.001 μ f	Cer.	500 v	GMV	283-000
	353-2340	.01 μ f	PTM	400 v		285-510
	2341-up	.01 μ f	Cer.	500 v	GMV	283-002
C6721		.01 μ f	Cer.	500 v	GMV	283-002
C6731	X353-up	.005 μ f	Cer.	500 v	GMV	283-001
C6741	X2341-up	.005 μ f	Cer.	500 v	GMV	283-001

Inductors

L6101A,B	X353-6552X	4-Section Plate Peaking Network				(2) *108-097
L6101A,B	X6779-up	4-Section Plate Peaking Network				(2) *108-097
L6101	X6553-6778X	1.5-2.5 μ h		Var.		*114-089
L6121	X6553-6778X	1.5-2.5 μ h		Var.		*114-089
L6201	101-352X	1.4 μ h				*108-095
L6211	101-352X	1.4 μ h				*108-095
L6221	101-352X	.3-.5 μ h		Var.	core 276-032	*114-037
L6231	101-352X	.3-.5 μ h		Var.	core 276-032	*114-037
L6561		.45 μ h				*108-062
L6571		.45 μ h				*108-062
L6601	X353-up	.18 μ h				*108-009
L6611	X353-up	.18 μ h				*108-009

Resistors

Resistors are fixed, composition, $\pm 10\%$ unless otherwise indicated.

R5001	X353-2050	33 Ω	$\frac{1}{2}$ w			302-330
	2051-6025	56 Ω	$\frac{1}{2}$ w			302-560
	6026-up	62 Ω	$\frac{1}{2}$ w		5%	301-620
R5011	X353-up	47 Ω	$\frac{1}{2}$ w			302-470
R5061		500 k	$\frac{1}{2}$ w	Prec.	1%	309-140
R5071		1 meg	$\frac{1}{2}$ w	Prec.	1%	309-148
R5111		750 k	$\frac{1}{2}$ w	Prec.	1%	309-141
R5121		333 k	$\frac{1}{2}$ w	Prec.	1%	309-139
R5161		900 k	$\frac{1}{2}$ w	Prec.	1%	309-142
R5171		111 k	$\frac{1}{2}$ w	Prec.	1%	309-138
R5211		950 k	$\frac{1}{2}$ w	Prec.	1%	309-143
R5221		52.6 k	$\frac{1}{2}$ w	Prec.	1%	309-137
R5261		975 k	$\frac{1}{2}$ w	Prec.	1%	309-144
R5271		25.6 k	$\frac{1}{2}$ w	Prec.	1%	309-136
R5281		100 Ω	$\frac{1}{2}$ w			302-101
R5311		990 k	$\frac{1}{2}$ w	Prec.	1%	309-145
R5321		10.1 k	$\frac{1}{2}$ w	Prec.	1%	309-135
R5331		100 Ω	$\frac{1}{2}$ w			302-101
R5341		10 Ω	$\frac{1}{2}$ w			302-100
R5361		995 k	$\frac{1}{2}$ w	Prec.	1%	309-146

Resistors (continued)

							Tektronix Part Number
R5371	101-352	5.025 k	1/2 w				Use 309-134
	353-up	5.03 k	1/2 w			Prec.	309-134
R5381		100 Ω	1/2 w				302-101
R5391		10 Ω	1/2 w				302-100
R5401		82 Ω	1/2 w				302-820
R5411		997.5 k	1/2 w			Prec.	309-147
R5421	101-352	2.506 k	1/2 w				Use 309-133
	353-up	2.51 k	1/2 w			Prec.	309-133
R5431		330 Ω	1/2 w				302-331
R5441		10 Ω	1/2 w				302-100
R5511	101-352X	100 k	2 w	Var.		DC BAL.	311-026
R5521	101-352X	390 k	1/2 w				302-394
R5551	101-352X	3.9 meg	1/2 w				302-395
R5561	101-352X	27 Ω	1/2 w				302-270
R5571	101-352X	3.9 k	1/2 w				302-392
R5601	X353-up	33 Ω	1/2 w				302-330
R5651		1 meg	1/2 w			Prec.	309-148
R5661		1 meg	1/2 w				302-105
R5671	101-352	220 Ω	1/2 w				302-221
	353-up	47 Ω	1/2 w				302-470
R5701	101-352	22 k	2 w				306-223
	353-up	47 Ω	1/2 w				302-470
R5711		22 k	2 w				306-223
R5721	101-352X	47 Ω	1/2 w				302-470
R5741	101-352X	47 Ω	1/2 w				302-470
R6021	101-109	220 Ω	1/2 w				302-221
	110-352X	27 Ω	1/2 w				302-270
R6031		27 Ω	1/2 w				302-270
R6041	101-352	5.6 k	2 w				306-562
	353-up	1.5 k	1 w				304-152
R6051	101-352	5.6 k	2 w				306-562
	353-up	1.5 k	1 w				304-152
R6061		4.5 k	5 w			WW	308-066
R6081		5 k		Var.		WW	311-012
R6101	101-11870	360 Ω		Var.		WW	Use *050-033
	11871-up	680 Ω		Var.		WW	Use *311-291
R6111	X353-up	27 Ω	1/2 w				302-270
R6121	101-352	22 k	1 w				304-223
	353-up	5.6 k	2 w				306-562
R6131	X353-up	10 k	1/2 w				302-103
R6201	101-352X	120 Ω	1/2 w				302-121
R6211	101-352X	120 Ω	1/2 w				302-121
R6221	101-6778	500 Ω	1/2 w	Mica Plate		2%	Use *310-551
	6779-up	515 Ω	1/2 w	Mica Plate			*310-551
R6231	101-6778	500 Ω	1/2 w	Mica Plate			Use *310-551
	6779-up	515 Ω	1/2 w	Mica Plate		2%	*310-551
R6241	101-352X	10 Ω	1/2 w				302-100
R6261	101-352X	2 k	5 w			WW	308-003
R6261A	X353-up	1.5 k	5 w			WW	308-061
R6261B	X353-up	470 Ω	2 w				306-471

Resistors (continued)

						Tektronix Part Number
R6281	101-109	27 Ω	1/2 w			302-270
	110-352X	10 Ω	1/2 w			302-100
R6301	101-352	68 k	1/10 w			307-006
	353-up	100 k	1/2 w			302-104
R6311	101-352	68 k	1/10 w			307-006
	353-up	100 k	1/2 w			302-104
R6321		2 x 100 k	2 w	Var.	Vert. Pos.	311-028
R6341	101-352X	22 k	1/2 w			302-223
R6381		82 k	1/2 w			302-823
R6391		82 k	1/2 w			302-823
R6401		2 x 100 k	2 w	Var.	Vert. Pos. Range	311-051
R6421	101-352X	10 k	1 w			304-103
R6481		27 Ω	1/2 w			302-270
R6491		27 Ω	1/2 w			302-270
R6501	101-3975	8.2 k	1 w			Use 303-822
	3976-up	8.2 k	1 w	Comp.	5%	303-822
R6511	101-3975	8.2 k	1 w			Use 303-822
	3976-up	8.2 k	1 w	Comp.	5%	303-822
R6521	X353-up	47 Ω	1/2 w			302-470
R6531	X353-up	47 Ω	1/2 w			302-470
R6541	X353-up	2 k	2 w	Var.	H.F. PEAKING	311-008
R6601	101-109	27 Ω	1/2 w			302-270
	110-352	10 k	1 w			304-103
	353-3101	8.2 k	1 w			Use 303-822
	3102-up	8.2 k	1 w	Comp.	5%	303-822
R6611	101-109	27 Ω	1/2 w			302-270
	110-352	10 k	1 w			304-103
	353-3101	8.2 k	1 w			Use 303-822
	3102-up	8.2 k	1 w	Comp.	5%	303-822
R6621	101-109	6.8 k	2 w			306-682
	110-352	10 k	1 w			304-103
	353-3101	8.2 k	1 w			Use 303-822
	3102-up	8.2 k	1 w	Comp.	5%	303-822
R6631	101-109	6.8 k	2 w			306-682
	110-352	10 k	1 w			304-103
	353-3101	8.2 k	1 w			Use 303-822
	3102-up	8.2 k	1 w	Comp.	5%	303-822
R6651	X110-up	3.9 k	2 w			306-392
R6701		47 Ω	1/2 w			302-470
R6721	X353-up	47 Ω	1/2 w			302-470
R6731	X353-up	100 Ω	2 w	Var.	DC BAL.	311-003
R6741	X353-up	12 Ω	1 w			304-120
R6751	X353-up	4.7 Ω	1 w			307-009
R6801	X353-up	33 Ω	2 w			306-330
R6811	X353-up	27 Ω	2 w			306-270
R6821	X353-up	39 Ω	2 w			306-390

Switches

			Tektronix Part Number	
			Wired	Unwired
SW5601		Rotary	AC/DC	
SW5651		Rotary	VOLTS/CM	
			*262-157	*260-122 *260-118

Electron Tubes

V5701	101-352	12AT7		
	353-up	6AK5		Use 154-039D
V6101 †	101-352	19X8		154-014
	353-up	12AU6	Selected	154-100
				Use *157-038
V6111 †	101-352	19X8		154-100
	353-up	12AU6	Selected	Use *157-038
V6501	101-4091	12AT7		Use 154-039D
	4092-up	12AT7		154-039D
V6551	101-4091	12AT7		Use 154-039D
	4092-up	12AT7		154-039D

† S/N 353-up, V6101 & V6111 are a matched pair furnished as a unit.

Type K Mechanical Parts List

	Tektronix Part Number
BRACKET, ALUM., VERT. POS. RANGE MTG. POT	406-127
BRACKET, ALUM., .063 x 1 ³ / ₈ x 1 ⁵ / ₁₆ x 1/2 Var. Gain Pot	406-161
BRACKET, HF PEAKING	406-186
BUSHING, ALUM., ³ / ₈ -32 x ⁹ / ₁₆ x .412 BP 18-18 anodized	358-010
CABLE, HARNESS	179-088
CAP, BINDING POST, BRASS ³ / ₈ OD x 1 ¹ / ₃₂ x 1/4-28 thread	200-103
CHASSIS, MAIN HORIZ.	441-120
CLAMP, CABLE 1/2" plastic	343-006
CLAMP, CABLE ³ / ₈ "	343-013
CONNECTOR, CHASSIS MT.	131-017
CONNECTOR, TERMINAL FEED THRU, 1 pt.	131-025
CONNECTOR, CHASSIS MT. UHF Receptacle, teflon center	131-051
GROMMET, RUBBER ³ / ₈ "	348-004
KNOB, LARGE BLACK 1/4 hole part way	366-042
KNOB, SMALL BLACK 1/4 hole part way	366-044
KNOB, SMALL BLACK 1/8 hole part way	366-045
KNOB, ALUM.	366-125
LOCKWASHER, STEEL EXT #2	210-002
LOCKWASHER, STEEL EXT #4	210-003
LOCKWASHER, STEEL INT #4	210-004
LOCKWASHER, STEEL INT #6	210-006
LOCKWASHER, STEEL INT #8	210-008
LOCKWASHER, STEEL INT 1/4	210-011
LOCKWASHER, STEEL POT INT ³ / ₈ x 1/2	210-012
LOCKWASHER, STEEL INT ³ / ₈ x 1 ¹ / ₁₆	210-013
LUG, SOLDER SE4	210-201
LUG, SOLDER Pot Plain ³ / ₈	210-207
NUT, HEX, BRASS 2-56 x ³ / ₁₆	210-405
NUT, HEX, BRASS 4-40 x ³ / ₁₆	210-406
NUT, HEX, BRASS 6-32 x 1/4	210-407
NUT, HEX, BRASS ³ / ₈ -32 x 1/2	210-413
NUT, HEX, STEEL 1/4-28 x ³ / ₈ x ³ / ₃₂	210-455
NUT, KEPS, STEEL 6-32 x ⁵ / ₁₆	210-457
NUT, HEX, ALUM. 6-32 x ⁵ / ₁₆	210-478
NUT, HEX, ALUM., ³ / ₈ -32 x 1/2 x 1 ¹ / ₁₆	210-494
PANEL, FRONT SN 101-3851	333-145
PANEL, FRONT SN 3852-up	Use 333-516

Mechanical Parts List (continued)

	Tektronix Part Number
PLATE, SUBPANEL	386-399
PLATE, ATTENUATOR BOTTOM 2 ³ / ₁₆ x 3 ¹ / ₂ x 1 ¹ / ₄	386-419
PLATE, ATTENUATOR TOP 2 ³ / ₁₆ x 3 ¹ / ₂ x 1 ¹ / ₄	386-420
POST, BINDING GROUND	129-035
PLATE 5 ¹ / ₃₂ x 6 ¹ / ₃₂	387-529
PLATE, SUBPANEL	386-399
RING, RETAINING #18 Securing Steel, free ID x .180	354-025
ROD, ALUM., 3/8 x 1 ¹ / ₁₆ tapped 8-32, thru SP502	385-011
ROD, NYLON 5/16 x 1 tapped 6-32 (15095-up)	385-016
ROD, NYLON 5/16 x 3/16 tapped 4-40	385-012
ROD, NYLON 5/16 x 1/2 tapped 6-32 (15095-up)	385-100
ROD, MISC., FRAME 3/8 x 8 ⁷ / ₈ tapped 8-32 both ends	384-508
ROD, MISC., SECURING 3/16 OD x 1 ¹ / ₂ -10-24 thread one end	384-510
SCREW, 4-40 x 1/4 BHS	211-008
SCREW 4-40 x 5/16 BHS	211-011
SCREW 4-40 x 3/8 BHS	211-012
SCREW 4-40 x 3/8 RHS	211-013
SCREW 4-40 x 7/8 RHS	211-018
SCREW 4-40 x 1 RHS	211-019
SCREW 4-40 x 1/4 FHS	211-023
SCREW 4-40 x 3/8 FHS	211-025
SCREW 4-40 x 5/16 Pan HS w/lockwasher	211-033
SCREW 6-32 x 1/4 BHS (15095-up)	211-504
SCREW 6-32 x 5/16 BHS	211-507
SCREW 6-32 x 3/8 FHS	211-509
SCREW 6-32 x 3/8 BHS	211-510
SCREW 6-32 x 5/16 FHS 100° CSK Phillips	211-538
SCREW 6-32 x 1/4 FHS (15095-up)	211-541
SCREW 6-32 x 3/4 THS	211-544
SCREW 6-32 x 3/8 FHS 100° CSK Phillips	211-559
SCREW 8-32 x 3/8 BHS	212-022
SCREW 8-32 x 1/2 FHS 100° Cad Plated Phillips	212-043
SCREW 8-32 x 1/2 RHS 100° Cad Plated Phillips	212-044
SCREW 5-32 x 3/16 Pan HS, thread cutting Phillips	213-044
SOCKET, STM7G	136-008
SOCKET, STM9G	136-015
STEM, BINDING POST ADAPTOR 3/8 x 1 ³ / ₁₆ brass, nickel plated	355-507
STRIP, CERAMIC CS 11-4	124-015
STRIP, CERAMIC 3/4 x 2 notches, clip-mounted	124-086
STRIP, CERAMIC 3/4 x 11 notches, clip-mounted	124-091

Mechanical Parts List (continued)

	Part Number Tektronix
TUBE, PLASTIC INSUL. #20 Black	162-504
TUBE, PLASTIC INSUL. #20 Red	162-510
TUBE, SPACING, ALUM. .089 ID x $\frac{3}{16}$ OD x $\frac{7}{16}$ lg.	166-085
WASHER, BRASS 5S	210-801
WASHER, STEEL 6L x $\frac{3}{8}$ x .032	210-803
WASHER, STEEL 8S x $\frac{3}{8}$ x .032	210-804
WASHER, FIBER #10	210-812
WASHER, FIBER $\frac{1}{8}$ ID x $\frac{1}{4}$ OD x .035	210-823
WASHER, STEEL .390 ID x $\frac{9}{16}$ OD x .020	210-840
WASHER, STEEL #2 flat .093 ID x $\frac{9}{32}$ OD x .020 thick	210-850
WASHER, POLYETHELENE .190 ID x $\frac{7}{16}$ OD x $\frac{1}{32}$ thick	210-894

V5701
INPUT C.F.

V6111
V6101
AMPLIFIERS

V6551
V6501
OUTPUT C.F.'S.

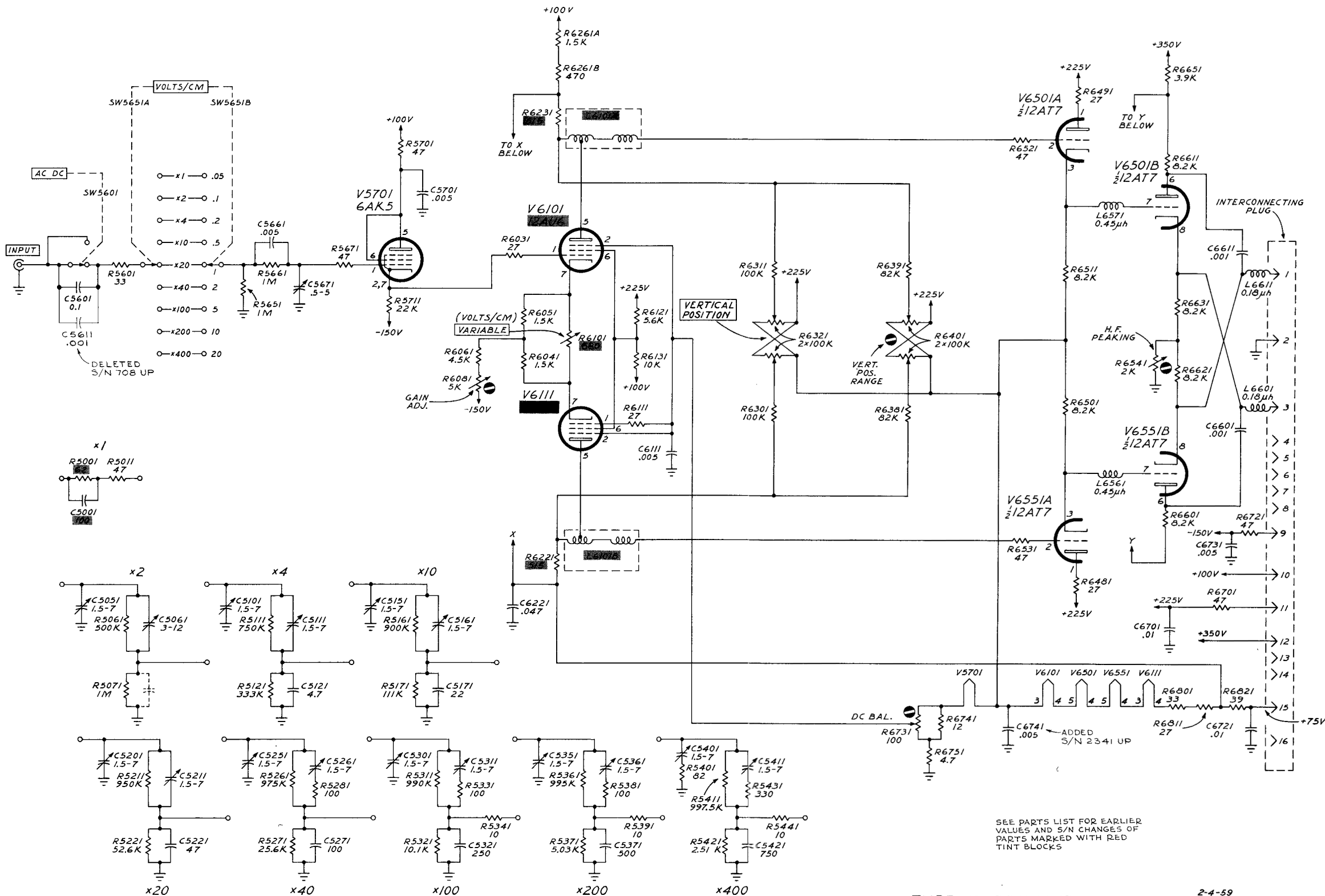

TYPE K PREAMP

2-4-59
KF

A B₂

MANUAL CHANGE INFORMATION

At Tektronix, we continually strive to keep up with latest electronic developments by adding circuit and component improvements to our instruments as soon as they are developed and tested.

Sometimes, due to printing and shipping requirements, we can't get these changes immediately into printed manuals. Hence, your manual may contain new change information on following pages. If it does not, your manual is correct as printed.

MOD 6860

Type B - Tent S/N 19130

Type D - Tent S/N 20560

Type G - Tent S/N 9480

Type K - Tent S/N 16210

Type L - Tent S/N 19090

Type CA - Tent S/N 56080

Connectors Change to Chassis Mtg.

BNC 131-277