

Bulk Metal® Foil Technology Dual-In-Line Hermetic Resistor Networks

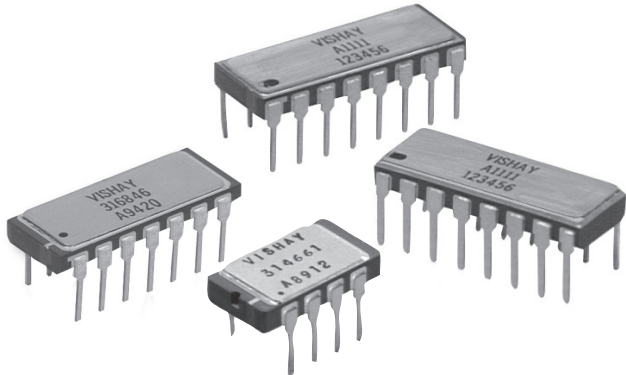

Product may not be to scale

Vishay Model 1442, 1445 and 1446 networks incorporate all the performance features of Vishay Bulk Metal® Foil technology. The 8, 14 and 16 pin side brazed DIPs are a ceramic package. Ceramic has the advantage of electrical isolation on the underside, and, in DIP form, a favorable pin arrangement when two networks are to be placed side by side and connected together.

Review data sheet "7 Technical Reasons to Specify Bulk Metal® Foil Resistor Networks."

Networks are built to your requirements. Send your schematic and electrical requirements to the Applications Engineering Department. (See data sheet "Network Worksheet.") A unique part number will be assigned which defines all aspects of your network.

FIGURE 1 - PACKAGE SIZES AND CHARACTERISTICS

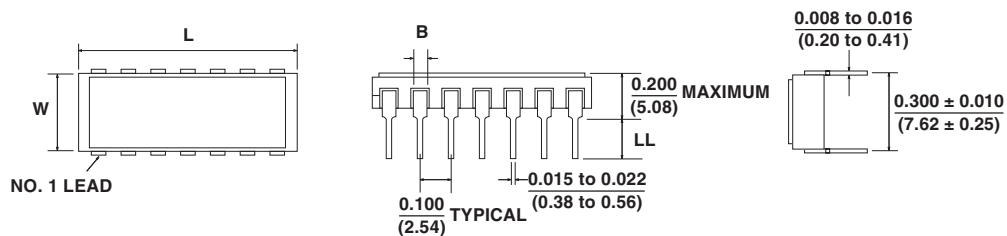

NOTE:

1. These networks utilize Vishay Bulk Metal® Foil resistor chips V5X5 and V15X5 or VTF15X5 Thin Film chips.
2. The V5X5 and V15X5 chips have maximum resistance values of 10K and 33K respectively in Bulk Metal® Foil and 500K in VTF15X5 Thin Film chips.
3. The V5X5 and V15X5 chip(s) can be intermixed in a package.

VISHAY MODEL	NO. OF PINS	MAXIMUM DIMENSIONS IN INCHES (MM)				CHIP CAPACITY		MAXIMUM POWER RATING (WATTS) AT + 70 °C
		L	W	H	LL	V5X5	V15X5	
1442	8	0.520 ± 0.020 (13.21 ± 0.51)	0.295 ± 0.010 (7.49 ± 0.025)	0.054 (1.37)	0.125 minimum (3.18)	12	4	0.4
1445	14	0.740 ± 0.045 (18.80 ± 1.14)	0.270 + 0.035/- 0.030 (6.86 + 0.89/- 0.76)	0.046 (1.17)	0.135 + 0.015/- 0.010 (3.43 + 0.38/- 0.25)	30	10	1.2
1446	16	0.780 ± 0.030 (19.81 ± 0.76)	0.290 ± 0.008 (7.37 ± 0.20)	0.040 to 0.070 (1.01 to 1.78)	0.135 + 0.015/- 0.010 (3.43 + 0.38/- 0.25)	36	12	1.4

FIGURE 2 - SAMPLE CIRCUIT DESIGN AND CHIP LAYOUT

NOTE:

Usable area is represented by the dotted lines - a rectangle 0.150 Inches x 0.200 Inches. Illustrations not to scale. Chips shown undersize for clarity. Drawing view is from the top looking down into the package.

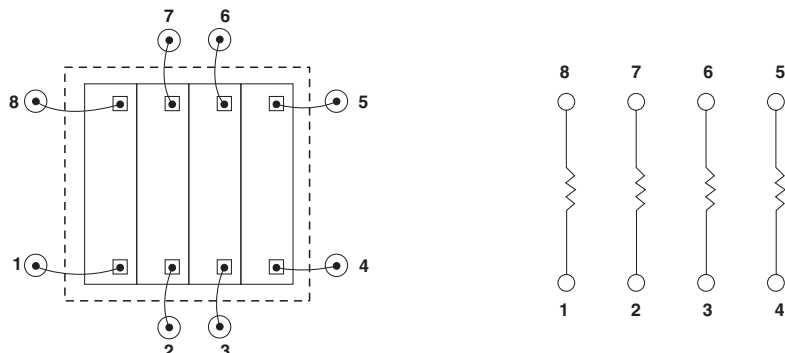

FIGURE 3 - SAMPLE CIRCUIT DESIGNS AND CHIP LAYOUTS

NOTE:

Usable area is represented by the dotted lines - a rectangle 0.150 Inches x 0.500 Inches. Illustrations not to scale.

Chips shown undersize for clarity. Drawing view is from the top looking down into the package.

TWO DECADES OF BCD LADDER PLUS TWO SCALING RESISTORS

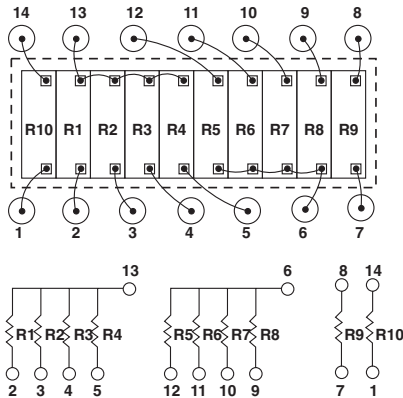

FOUR DIVIDERS PLUS APPLICATION RESISTOR

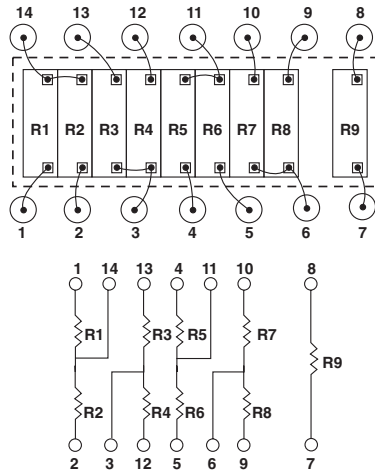

TEN RESISTOR DIVIDER

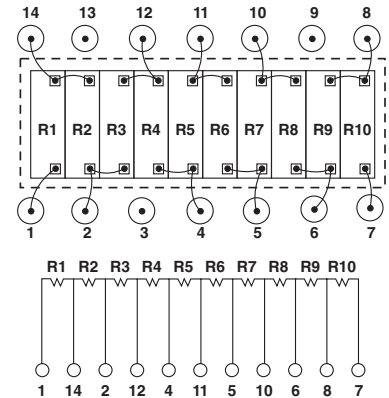
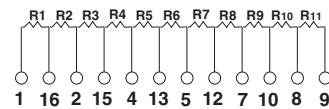
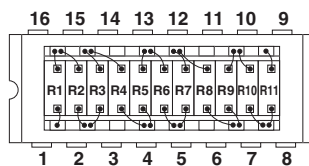

FIGURE 4 - SAMPLE CIRCUIT DESIGNS AND CHIP LAYOUTS

NOTE:

Usable area is represented by the dotted lines - a rectangle 0.150 Inches x 0.600 Inches. Illustrations not to scale. Chips shown undersize for clarity. Drawing view is from the top looking down into the package.

ELEVEN RESISTOR DIVIDER



EIGHT RESISTOR PACKAGE

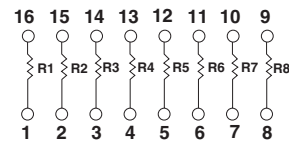
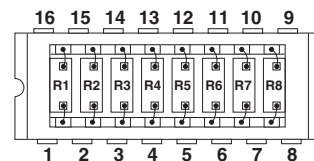

Disclaimer

ALL PRODUCTS, PRODUCT SPECIFICATIONS AND DATA ARE SUBJECT TO CHANGE WITHOUT NOTICE.

Vishay Precision Group, Inc., its affiliates, agents, and employees, and all persons acting on its or their behalf (collectively, "VPG"), disclaim any and all liability for any errors, inaccuracies or incompleteness contained herein or in any other disclosure relating to any product.

The product specifications do not expand or otherwise modify VPG's terms and conditions of purchase, including but not limited to, the warranty expressed therein.

VPG makes no warranty, representation or guarantee other than as set forth in the terms and conditions of purchase. **To the maximum extent permitted by applicable law, VPG disclaims (i) any and all liability arising out of the application or use of any product, (ii) any and all liability, including without limitation special, consequential or incidental damages, and (iii) any and all implied warranties, including warranties of fitness for particular purpose, non-infringement and merchantability.**

Information provided in datasheets and/or specifications may vary from actual results in different applications and performance may vary over time. Statements regarding the suitability of products for certain types of applications are based on VPG's knowledge of typical requirements that are often placed on VPG products. It is the customer's responsibility to validate that a particular product with the properties described in the product specification is suitable for use in a particular application. You should ensure you have the current version of the relevant information by contacting VPG prior to performing installation or use of the product, such as on our website at vpgsensors.com.

No license, express, implied, or otherwise, to any intellectual property rights is granted by this document, or by any conduct of VPG.

The products shown herein are not designed for use in life-saving or life-sustaining applications unless otherwise expressly indicated. Customers using or selling VPG products not expressly indicated for use in such applications do so entirely at their own risk and agree to fully indemnify VPG for any damages arising or resulting from such use or sale. Please contact authorized VPG personnel to obtain written terms and conditions regarding products designed for such applications.

Product names and markings noted herein may be trademarks of their respective owners.

Copyright Vishay Precision Group, Inc., 2014. All rights reserved.