

FEATURES

- Resistor Values over four Decades
- Kelvin Connection
- Resistance Tolerances to $\pm 0.1\%$
- TCR to $\pm 25\text{ppm/K}$
- Load Stability to 0.1%



RoHS*
COMPLIANT

TABLE 1 – SPECIFICATIONS				
TYPE		FPN	FHN 5426 / 6819 FHN 6426 / 7819	FHN 8526
Resistance Range		0.010 to 90 Ohms		
Power Rating	Free air 70°C	2 W	2 W	3 W
	With heatsink		20 W	30 W
Tolerances		0.1% / 0.25% / 0.5% / 1%		
Stability (1000h)		0.1% / 0.2% / 0.5% (depends on stress)		
Temperature Coefficient Standard (Q)		$\pm 25\text{ppm/K}$ (20 to 60°C) other specifications upon request		
Insulation Resistance		> 10 GOhm		
Voltage Proof		> 1 kVDC		
Maximum Current		25 A		
Thermal EMF		< 1 $\mu\text{V/K}$		
Operating Temperature Range		-40 to 130°C		
Resistor Material		CuNiMn-Foil		
Substrate		Anodized aluminium		
Housing		Epoxy / anodized aluminium		
Connector Material		Cu / tinned		
Contact		K - Standard		
Max. Torque			1 Nm	

ORDERING INFORMATION
Part Number - Type - Resistance - Contact - Tolerance - TCR
FHN 4-6426 C 0R100-0R900-9R00-90R000 K 0.5% Q

FIGURE 1 – TEMPERATURE COEFFICIENT

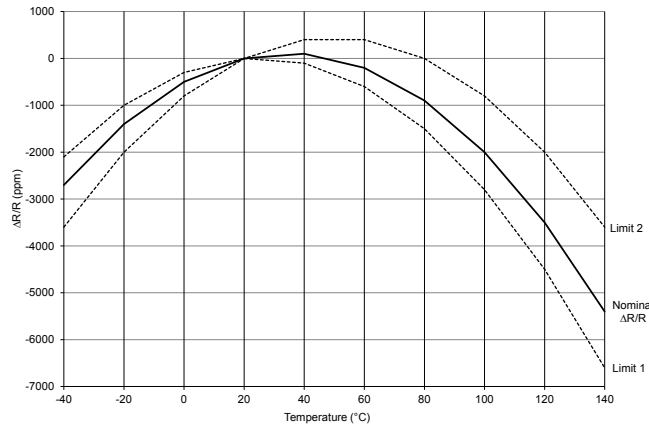

FIGURE 2 – DERATING

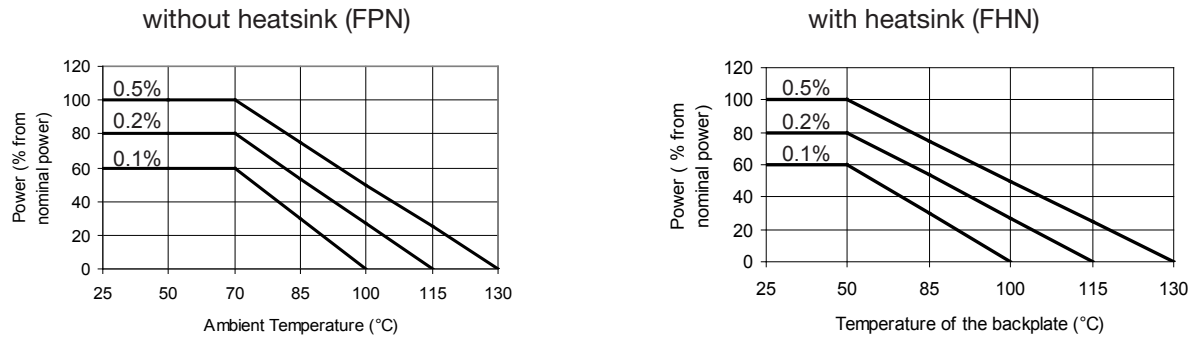

FIGURE 3 – RESISTANCE COMBINATIONS

Part	Type	Resistance Value Combination
FPN 3-4916 / FHN 3-5426 / FHN 3-6819	A	0.01 - 0.09 - 0.90 Ohms
	B	0.01 - 0.10 - 0.90 Ohms
	C	0.09 - 0.90 - 90.0 Ohms
	D	0.10 - 0.90 - 9.0 Ohms
	E	0.90 - 9.0 - 90.0 Ohms
	F	1.0 - 9.0 - 90.0 Ohms
	G	0.10 - 0.90 - 9.0 Ohms
FPN 4-5716 / FHN 4-6426 / FHN 4-7819	B	0.01 - 0.09 - 0.90 - 9.0 Ohms
	C	0.10 - 0.90 - 9.0 - 90.0 Ohms
	D	0.05 - 0.45 - 4.5 - 45.0 Ohms
	E	0.025 - 0.075 - 0.150 - 0.250 Ohms
FHN 4-8526	B	0.01 - 0.09 - 0.90 - 9.0 Ohms
FPN 5-4818	A	0.01 - 0.09 - 0.90 - 9.0 - 90.0 Ohms
	R	0.033 - 0.067 - 0.90 - 9.0 - 90.0 Ohms
FHN 6-8526	K	0.025 - 0.075 - 0.15 - 0.75 - 1.5 - 7.5 Ohms
FPN 7-6516	A	0.025 - 0.075 - 0.15 - 0.25 - 0.50 - 1.5 - 2.5 Ohms

FIGURE 4 – PATTERN

Pattern

The resistor networks can be configured upon request of the customer. The only restriction is the grid of 5.08mm between two contacts.

The point of the contact can be in a grid dimension of 2.54mm.

lead spacing : 0,1 inch = 2,54 mm

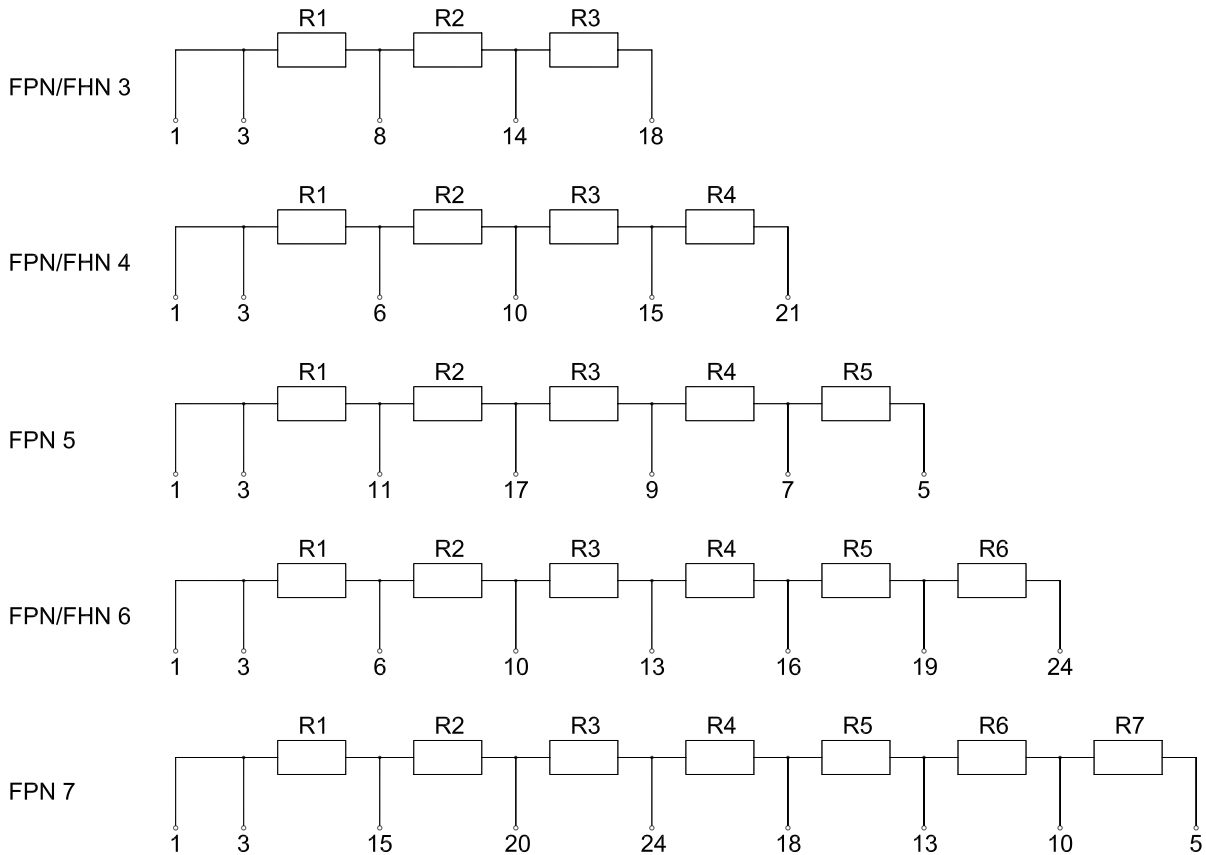
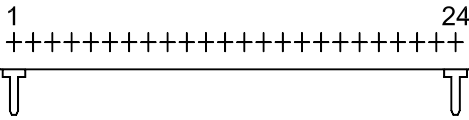
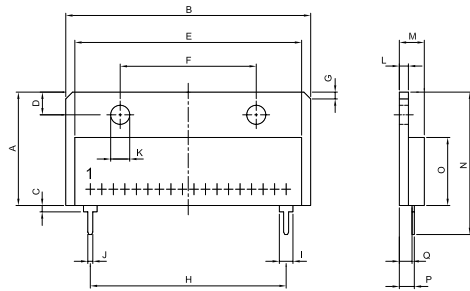
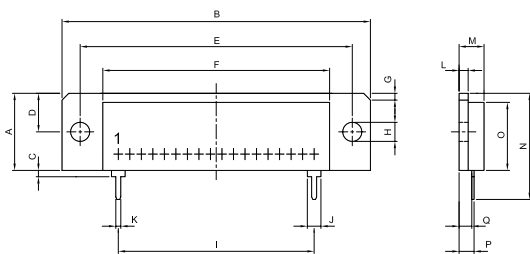

FIGURE 5 – DIMENSIONS in mm (inches)



Dimension	FHN 3-5426	FHN 4-6426
A ±0.2 (±0.008)	25.00 (0.98)	
B ±0.2 (±0.008)	54.00 (2.13)	64.00 (2.52)
C ±0.4 (±0.016)	1.40 (0.06)	
D ±0.1 (±0.004)	5.00 (0.20)	
E ±0.3 (±0.012)	50.00 (1.97)	60.00 (2.36)
F ±0.2 (±0.008)	30.00 (1.18)	35.00 (1.38)
G ±0.1 (±0.004)	1.5x45° (0.6x45°)	
H ±0.3 (±0.012)	43.18 (1.70)	50.80 (2.00)
I ±0.1 (±0.004)	3.00 (0.12)	
J ±0.1 (±0.004)	1.10 (0.04)	
K ±0.1 (±0.004)	4.20 (0.17)	
L ±0.1 (±0.004)	2.00 (0.08)	
M ±0.2 (±0.008)	max.5.5 (0.22)	
N ±0.3 (±0.012)	31.40 (1.24)	
O ±0.2 (±0.008)	15.00 (0.59)	
P ±0.1 (±0.004)	3.30 (0.13)	
Q ±0.1 (±0.004)	2.80 (0.11)	



Dimension	FHN 3-6819	FHN 4-7819
A ±0.2 (±0.008)	17.00 (0.67)	
B ±0.3 (±0.012)	68.00 (2.68)	78.00 (3.07)
C ±0.4 (±0.016)	1.40 (0.06)	
D ±0.2 (±0.008)	8.50 (0.33)	
E ±0.3 (±0.012)	60.00 (2.36)	70.00 (2.76)
F ±0.2 (±0.008)	50.00 (1.97)	60.00 (2.36)
G ±0.1 (±0.004)	1.5x45° (0.6x45°)	
H ±0.1 (±0.004)	4.20 (0.17)	
I ±0.3 (±0.012)	43.18 (1.70)	50.80 (2.00)
J ±0.1 (±0.004)	3.00 (0.12)	
K ±0.1 (±0.004)	1.10 (0.04)	
L ±0.1 (±0.004)	2.00 (0.08)	
M ±0.2 (±0.008)	max. 5.5 (0.22)	
N ±0.2 (±0.008)	23.40 (0.92)	
O ±0.2 (±0.008)	15.00 (0.59)	
P ±0.1 (±0.004)	3.30 (0.13)	
Q ±0.1 (±0.004)	2.80 (0.11)	

FIGURE 5 – DIMENSIONS in mm (inches)

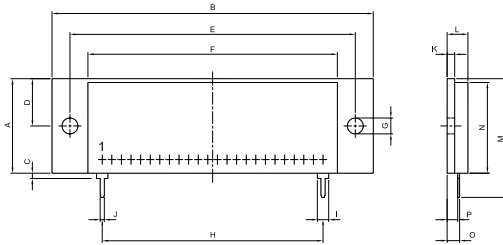

Dimension	FHN 4-8526	FHN 6-8526
A ±0.2 (±0.008)	25.00 (0.98)	
B ±0.3 (±0.012)	85.00 (3.35)	
C ±0.2 (±0.008)	1.00 (0.04)	
D ±0.2 (±0.008)	12.50 (0.49)	
E ±0.3 (±0.012)	75.50 (2.97)	
F ±0.3 (±0.012)	66.00 (2.60)	
G ±0.1 (±0.004)	4.20 (0.17)	
H ±0.3 (±0.012)	50.80 (2.00)	58.42 (2.30)
I ±0.1 (±0.004)	3.00 (0.12)	
J ±0.1 (±0.004)	1.10 (0.04)	
K ±0.1 (±0.004)	2.00 (0.08)	
L ±0.2 (±0.008)	max. 5.5 (0.22)	
M ±0.3 (±0.012)	31.00 (1.22)	
N ±0.2 (±0.008)	24.00 (0.94)	
O ±0.1 (±0.004)	3.30 (0.13)	
P ±0.1 (±0.004)	2.80 (0.11)	

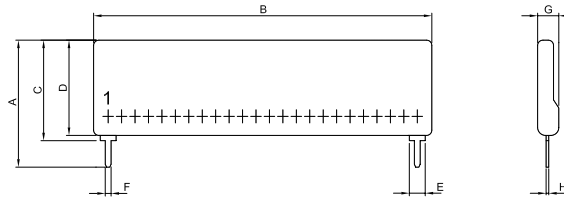

Dimension	FPN 3-4916	FPN 4-5716	FPN 5-4818	FPN 7-6516
A ±0.2 (±0.008)	21.50 (0.85)		23.50 (0.93)	21.50 (0.85)
B ±0.3 (±0.012)	49.00 (1.93)	57.00 (2.24)	48.00 (1.89)	65.00 (2.56)
C ±0.2 (±0.008)	16.50 (0.65)		18.50 (0.73)	16.50 (0.65)
D ±0.2 (±0.008)	15.50 (0.61)		17.50 (0.69)	15.50 (0.61)
E ±0.1 (±0.004)	3.00 (0.12)			
F ±0.1 (±0.004)	1.10 (0.04)			
G ±0.2 (±0.008)	2.80 - 3.20 (0.11 - 0.13)			
H ±0.1 (±0.004)	0.50 (0.02)			



Disclaimer

ALL PRODUCTS, PRODUCT SPECIFICATIONS AND DATA ARE SUBJECT TO CHANGE WITHOUT NOTICE.

Vishay Precision Group, Inc., its affiliates, agents, and employees, and all persons acting on its or their behalf (collectively, "VPG"), disclaim any and all liability for any errors, inaccuracies or incompleteness contained herein or in any other disclosure relating to any product.

The product specifications do not expand or otherwise modify VPG's terms and conditions of purchase, including but not limited to, the warranty expressed therein.

VPG makes no warranty, representation or guarantee other than as set forth in the terms and conditions of purchase. **To the maximum extent permitted by applicable law, VPG disclaims (i) any and all liability arising out of the application or use of any product, (ii) any and all liability, including without limitation special, consequential or incidental damages, and (iii) any and all implied warranties, including warranties of fitness for particular purpose, non-infringement and merchantability.**

Information provided in datasheets and/or specifications may vary from actual results in different applications and performance may vary over time. Statements regarding the suitability of products for certain types of applications are based on VPG's knowledge of typical requirements that are often placed on VPG products. It is the customer's responsibility to validate that a particular product with the properties described in the product specification is suitable for use in a particular application. You should ensure you have the current version of the relevant information by contacting VPG prior to performing installation or use of the product, such as on our website at vpgsensors.com.

No license, express, implied, or otherwise, to any intellectual property rights is granted by this document, or by any conduct of VPG.

The products shown herein are not designed for use in life-saving or life-sustaining applications unless otherwise expressly indicated. Customers using or selling VPG products not expressly indicated for use in such applications do so entirely at their own risk and agree to fully indemnify VPG for any damages arising or resulting from such use or sale. Please contact authorized VPG personnel to obtain written terms and conditions regarding products designed for such applications.

Product names and markings noted herein may be trademarks of their respective owners.

Copyright Vishay Precision Group, Inc., 2014. All rights reserved.