



# TruckWeigh™ Installation, Setup and Calibration Manual

## SI Onboard

A Brand of VPG On-Board Weighing

### **IMPORTANT INSTALLATION INFORMATION AND LIABILITY WAIVER**

*SI Onboard* designs and manufactures on-board vehicle weighing equipment. These installation guidelines are provided solely for the use of trained installers and represent the correct, safe and recommended method of installation. They must be followed fully to ensure proper, safe installation. Failure to do so may result in serious consequences including, but not limited to, failure of the system to function properly and damage to the weighing equipment that could jeopardize the stability and safety of the vehicle.

*SI Onboard* accepts no responsibility or liability for consequences arising from any improper installation of the weighing equipment including but not limited to, any misapplication or misinterpretation of the installation information contained herein.

Strict observance of these guidelines should help to ensure accurate weight measurement and enable safe operation of the vehicle. Failure of our on-board vehicle weighing equipment due to poor installation workmanship or incorrectly installed elements remains solely the responsibility of the installer.

*SI Onboard* does not accept responsibility for the structural integrity of the vehicle concerned, for any part thereof, and for its proper, safe operation.

The company also reserves the right to make any amendments and alterations to this document deemed necessary. You should ensure you have the current version of this information by contacting *SI Onboard* prior to performing installation, such as on our website at [www.obwvpg.com](http://www.obwvpg.com)

Installation.....	5
Introduction and Scope.....	6
Introduction.....	6
Scope.....	6
TruckWeigh™ Components.....	7
Tools required.....	8
Checklist.....	8
Typical System Schematics.....	9
Installation of Junction Box for TruckWeigh™ Axle Transducers.....	10
Installation of Air Transducer Interface Box.....	10
Installation of Air Pressure Transducer.....	11
Steel Axle Transducer Installation.....	12
Positioning of Transducers on Front Strut Type Suspension.....	13
Positioning of Steel Axle Transducers on Front Leaf Springs.....	13
Positioning of Transducers on Rear Single Axle Leaf Springs.....	14
Positioning of Transducers on Rear Steel Spring Bogie (Tandem Axle).....	15
Positioning of Transducers on Rear Hendrickson Rubber Bogie.....	15
Axle Transducer Mounting.....	16
Points to consider.....	16
Connect the Transducers to the Junction Box.....	17
Install the Chassis and Cab Cabling.....	18
Securing Excess Cable.....	18
Optional Jumper Settings.....	19
Power ON Jumper – JP1.....	19
Serial Power On Pin 9.....	19
Serial Power On Pin 9 – JP2.....	19
Install the Meter in the Cab.....	20
Installing the Meter.....	20
Install Truck to Trailer Cable – Truck Side.....	22
Install Truck to Trailer Cable – Trailer Side.....	22
Install 511 Transmitter (Optional).....	22
Install Printer (Optional).....	22

<b>Setup</b> .....	23
<b>Introduction and Scope</b> .....	24
<b>Introduction</b> .....	24
<b>Scope</b> .....	24
<b>Front Panel Functionality</b> .....	25
<b>Power Up the Meter for the First Time</b> .....	26
<b>Entering the Setup Menu</b> .....	26
<b>Changing a Parameter Value</b> .....	26
<b>How to change a parameter value</b> .....	26
<b>Obtain the Truck's GVWR and Axle Ratings</b> .....	27
<b>Junction Box Configuration - Overview</b> .....	27
<b>Junction Box Configuration – Examples</b> .....	28
<b>Junction Box Configuration</b> .....	28
<b>Set the Number of Axles and Check the Weigh Mode</b> .....	29
<b>Set the Meter's Time and Date</b> .....	29
<b>Set the Overload Alarm Set Points</b> .....	29
<b>Set the Slope Compensation</b> .....	30
<b>Configure Tandem Axle (Bogie) Mode</b> .....	31
<b>Tag Axle – Overview</b> .....	32
<b>Configure Tag Axle – if Required</b> .....	34
<b>Configure Optional 511 Transmitter</b> .....	34
<b>Configure Optional Printer</b> .....	35
<b>Record the Firmware Versions and Other Details</b> .....	35
<b>Set the Manager and User PINs</b> .....	35
<b>Calibration</b> .....	37
<b>TruckWeigh™ Calibration Process</b> .....	38
<b>Prerequisites</b> .....	38
<b>Weighing the Vehicle</b> .....	38
<b>Procedure</b> .....	39
<b>Appendices</b> .....	43
<b>Junction Box Configuration Diagrams</b> .....	44
<b>4x2 Rigid Chassis</b> .....	44
<b>6x4 Rigid Chassis</b> .....	45
<b>8x4 Rigid Chassis</b> .....	46
<b>4x2 Rigid Chassis</b> .....	47
<b>4x2 Tractor/Trailer</b> .....	48
<b>6x4 Tractor/Trailer</b> .....	49
<b>4x2 Tractor/Trailer</b> .....	50
<b>Summary of Settings/Parameters</b> .....	51
<b>Parts list</b> .....	57

# Installation

## Introduction and Scope

**Please read this installation guide completely before starting the installation so that all areas are fully understood.**

### Introduction

TruckWeigh™ is a vehicle payload optimization, overload monitoring and load distribution system for use on vehicles with steel spring or air suspension or a combination of the two.

### Scope

This document is intended as a guide to the installation of TruckWeigh™.

It is only concerned with the two currently supported transducer types for use in a TruckWeigh™ system:

- TruckWeigh™ axle transducers that measure suspension deflection for use on mechanically spring suspension systems.
- Air pressure transducers for use on air suspension systems.

In order to support known chassis types, various system options can be configured using either of the above transducers or certain combinations of the two.

Any display screenshots used in this document are intended as an illustration of the menu function being described; as such any specific detail or settings shown will differ from one installation to another.

#### **Attention:**

The TruckWeigh™ indicator has a certain amount of legacy functionality available through its menu structure which is not considered to be a part of the TruckWeigh™ program, hence is not supported and falls outside the scope of this guide.

#### **Important Notes:**

To ensure a reliable and properly functioning system particular importance should be paid to the following:

- TruckWeigh™ axle transducer installation and configuration – suitable location and orientation for the transducer should be carefully identified and that location should then be prepared for the transducer to be attached.
- Slope compensation should also be recorded correctly.

These are covered in detail in this installation guide.

### TruckWeigh™ Components

Before starting the installation check that you have the correct kit of parts for the truck. See Appendix C for a full parts list including part numbers.

#### Axle Transducer



Fig 1.01

Each steel suspension axle uses a pair of TruckWeigh™ axle transducers.

For example:

- 4x2 all steel suspension would require 4 axle transducers.
- 6x4 all steel suspension would require 6 axle transducers.
- 8x4 all steel suspension would require 8 etc.

#### CAN Junction Boxes



Fig 1.02

The axle transducers connect to the meter via junction boxes.

The 4 way junction box (used also as 2 way junction box).

- 1x4 way is used for 1 axle/2 transducers with unused ports blanked off with dust covers.
- 1x4 way is also used for 2 axle/4 transducer installations.
- 2x4 way is used for 4 axle/8 transducer installations.

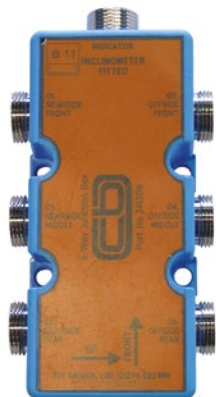

Fig 1.03

6-way junction box

- The 6 way junction box is only used for 3 axle/6 transducer installations.

#### Single Air Transducer and Interface



Fig 1.04

Air suspension groups will use an air transducer and interface unit for each group. An air group can be 1 or more axles connected to the same air circuit.

#### Dual Air Transducer and Interface



Fig 1.05

Where pressure is controlled independently on left and right hand sides a dual air transducer unit must be used.

#### TruckWeigh™ Meter



Fig 1.06

There is only one meter per system; this is where the weights are calculated.

The meter is used for all display, setup, calibration and diagnostic functions.

#### Power Cable



Fig 1.07

The power cable is used to connect the meter to the truck power. There is one per meter.

#### Signal Cable



Fig 1.08

The signal cable connects the meter to one or more junction boxes. There is one signal cable per junction box.

### Interlink Cable



Fig 1.09

The interlink cables are used to extend each transducer cable and connect it to the junction box. Normally one cable is used per transducer. In some cases the axle transducer may reach the junction box without the use of an interlink cable.

### Signal Y Splitter



Fig 1.10

The Signal Y Splitter cable is used when it is necessary to connect two signal cables to the meter, for example, on an 8x4 where two 4way junction boxes are used.

### Truck to Trailer Cable – Truck Part



Fig 1.11

This is used only on articulated vehicles, one per system.

### Truck to Trailer Cable – Trailer Part



Fig 1.12

This is used only on articulated vehicles, one per system.

#### Please note:

Some optional items are not shown here.

These are:

1. 511 hand held display transmitter
2. Thermal printer

They are shown along with their installation details at the rear of this section of the guide.

## Tools required

### Checklist

✓	7/16" wrench
✓	7/16" socket and ratchet wrench
✓	1/4" wrench (if installing a truck to trailer cable)
✓	1/4" socket and ratchet wrench (if installing a truck to trailer cable)
✓	Center punch
✓	Air or electric drill
✓	1/8" drill bit
✓	9/32" drill bit
✓	3/16" drill bit (if installing a truck to trailer cable)
✓	Wire cutters
✓	Red, yellow and blue crimping tool
✓	Wire strippers
✓	Clamps (to apply pressure to the axle transducers during installation)



### Typical System Schematics

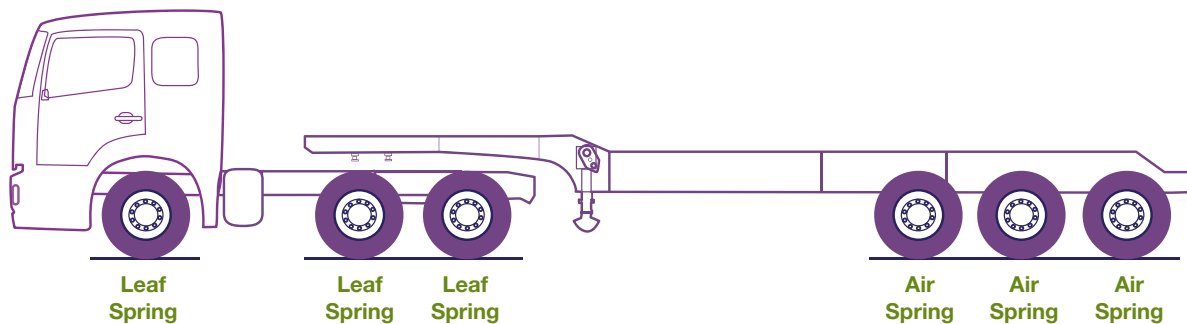

Fig 1.13

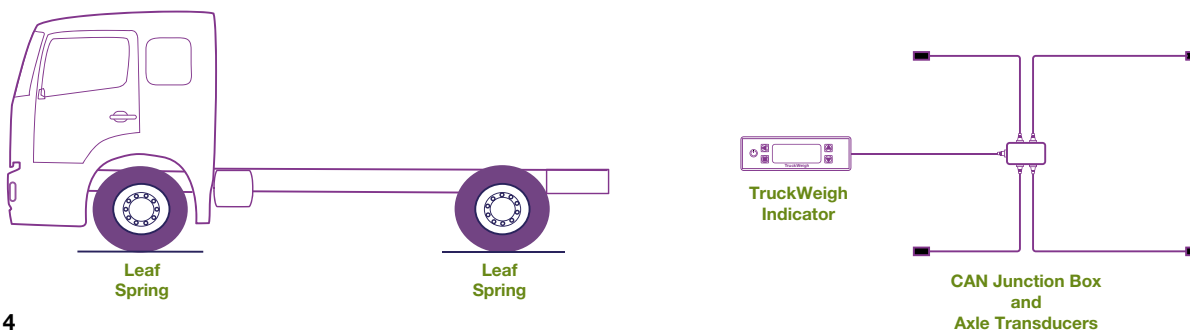
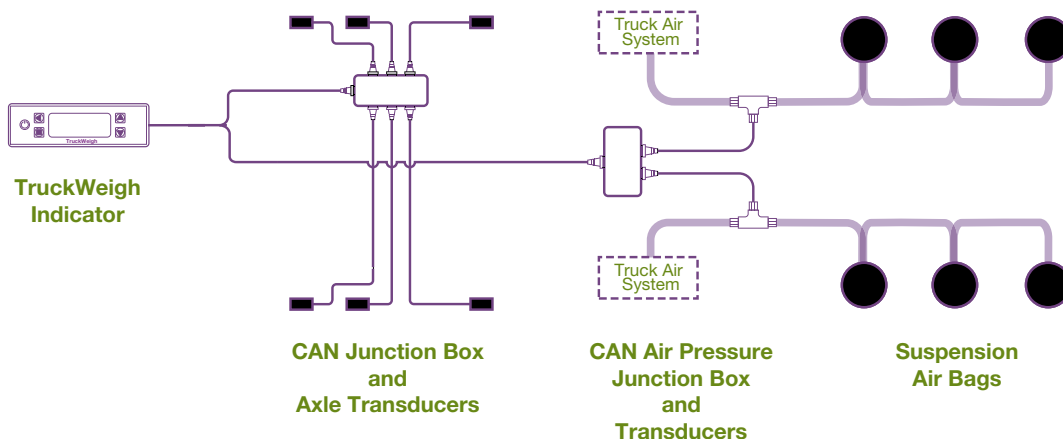

Fig 1.14

The above diagrams are examples only and show how systems on rigid and articulated vehicles might look.

### Installation of Junction Box for TruckWeigh™ Axle Transducers

For trucks with mechanical suspension, install one or more junction boxes.

Identify a suitable location for the junction box:

- Each junction box needs to be located close enough to the transducers so the cables reach it.
- Each junction box must be mounted on a vertical surface of the chassis or sub frame with the 'UP' arrow pointing straight up and the 'FORWARD' arrow pointing towards the front of the truck.
- Select a location that is relatively protected and easy to access.

**Fig. 1.15** is shown as an example only. It may be desirable to mount the junction box to the chassis via a separate mounting plate that picks up existing chassis holes. The junction boxes are mounted using 2 or 4 x ¼" x 1" screws and Nyloc nuts. Socket cap head or Phillips head machine screws should be used, do not use hex head bolts. Depending on where it is mounted, different length screws may be required.



**Fig 1.15**

### Installation of Air Transducer Interface Box



**Fig 1.16**

For trucks and trailers with air suspension, install one or more air transducer interface boxes.

Identify a suitable location for each junction box:

- Each junction box needs to be located close enough to the transducer positions for the cables to reach it.
- Choose a position that is protected and easy to access.

The air transducer interface box is mounted using 4 x ¼" x 1" screws and Nyloc nuts. Depending on where it is mounted, different length screws may be required.

If desired, drill 2 or 4 pilot holes with a ⅛" drill.

Drill 4 x ⅜" holes in an appropriate location and mount the air transducer interface box in a similar way to that shown in the photo above.

The air transducer interface box can be mounted in any orientation, ideally the cable glands to the air pressure transducers should point downwards.

### Installation of Air Pressure Transducer

Decide on where to position the air transducer in the suspension air circuit. The air transducer must be between the self-leveling valve and the air bellows, as shown below in figures 1.17 and 1.18).

**Circuit prior to installing the air transducer.**

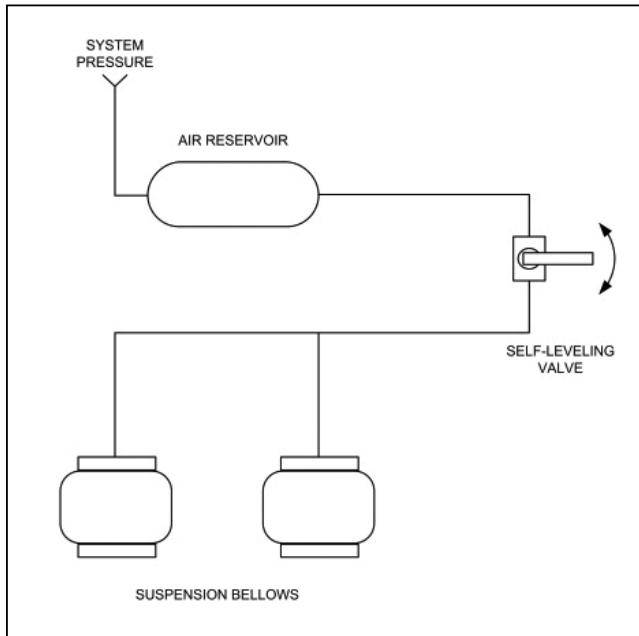

**Fig 1.17**



**Fig 1.18**

Find a location where the air pipe is well supported and there is space for the air transducer to be installed properly without fouling anything.

**Circuit with air transducer installed.**

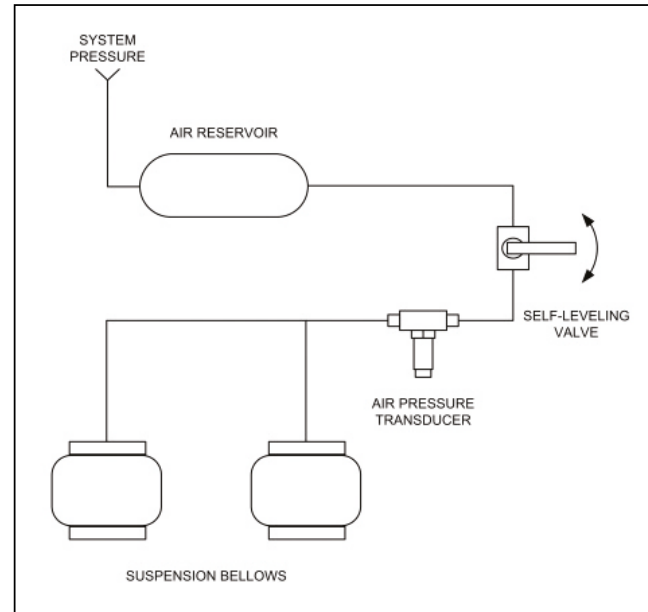

**Fig 1.19**

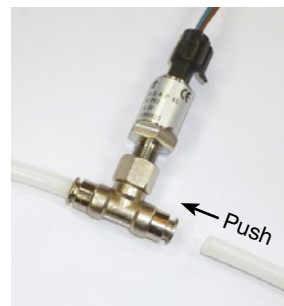

**Fig 1.20**

Cut the air pipe and insert the 2 ends into the air transducer push fit couplers as shown below.

Make the connection from the air transducer interface box to the air transducer, running and securing the cable following the usual precautions:

- Ensure that cable to cable connections are well supported.
- Avoid running cables on or near sharp objects.
- Keep cables away from hot components such as exhausts and engines.

It is recommended that self-amalgamating tape is wrapped around the air transducer connector and a little way up the cable.

### Steel Axle Transducer Installation

If the system uses steel axle transducers, you will need to firstly decide the correct location for the transducers. The transducers must be mounted on as flat a surface as possible to ensure a strong bond of the adhesive that retains the transducer.

There are some basic rules for transducer orientation:

- Each transducer must be mounted with the groove around the transducer on top, as shown below (in figure 1.21).
- Each transducer must always be mounted inline with the chassis (unless they are on struts) in such a way as to ensure the face adjacent to each groove is facing up (see figure 1.21).
- The cable from the transducer must always point from the transducer in the direction of the pivot point of the suspension component to which it is attached. See Fig 2.12 for more information.

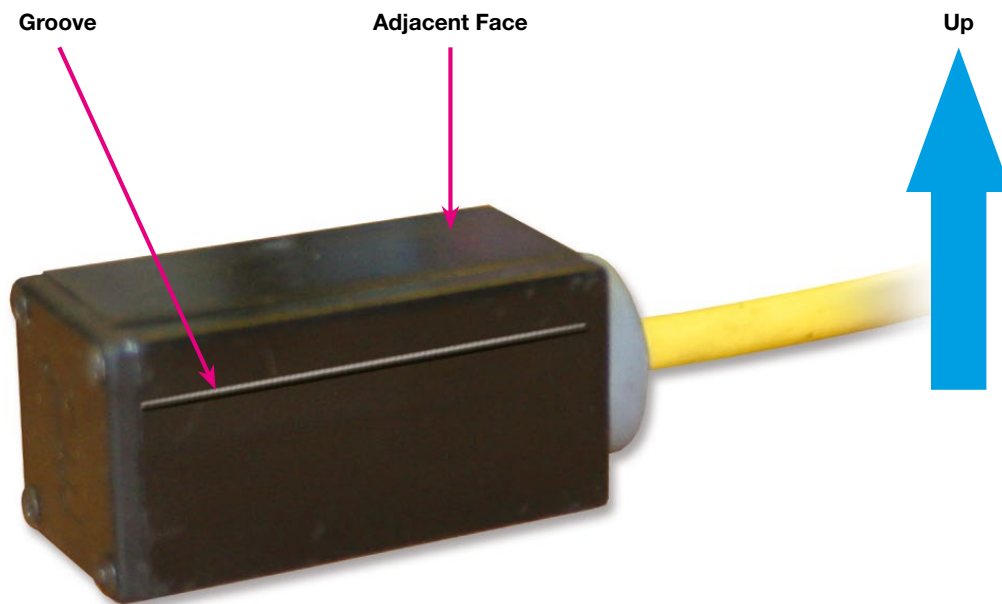

Fig 1.21

## Positioning of Transducers on Front Strut Type Suspension

With strut type front suspension mount the transducers as shown (see figure 1.22):

- When installing transducers to a strut type suspension they must be installed perpendicular to the truck chassis.
- When the transducers are installed to this type of suspension and in this orientation they are not subjected to the slope compensation correction, therefore the relevant axle would be configured in the meter as “Slope Compensation – none”. Record the transducer orientation into the *Installation & Calibration Record* for entry into the meter during its setup.



Fig 1.22

## Positioning of Steel Axle Transducers on Front Leaf Springs

The transducers can be mounted on either end of the leaf spring as shown in the diagrams below. Care should be taken to ensure the transducer cannot come into contact with any part of the vehicle during the full range of movement of the spring.

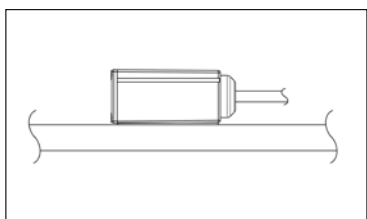

**Note:** Position of groove

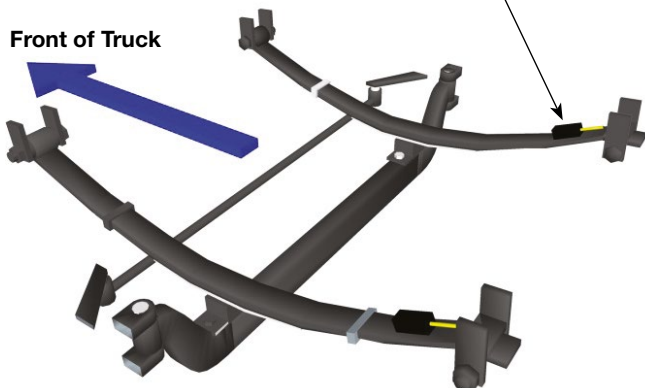

Fig 1.23

- When the transducers are mounted in this orientation they are referred to as “leading”. (see figure 1.23)
- Record the transducer orientation into the *Installation & Calibration Record* for entry into the meter during its setup.

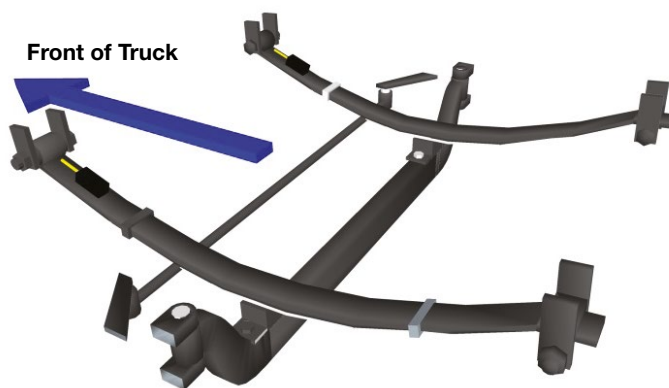

Fig 1.24

The transducers may also be mounted at the front of the leaf spring as shown above.

- When the transducers are mounted here they are referred to as “trailing” (see figure 1.24).
- Record the transducer orientation into the *Installation & Calibration Record* for entry into the meter during its setup.



Fig 1.25

Remember to leave only enough loose cable to allow the transducer to move with the spring without pulling the cable tight. Excessive loose cable may result in the cable being snagged (see figure 1.25).



### Positioning of Transducers on Rear Single Axle Leaf Springs

The transducers can be mounted on either side of the leaf spring as shown in the diagrams below. Care should be taken to ensure the transducer cannot come into contact with any part of the vehicle during the full range of movement of the spring.

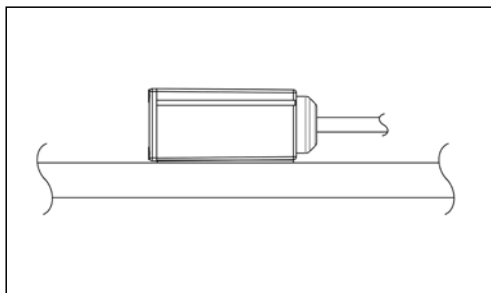

**Note:** Position of groove

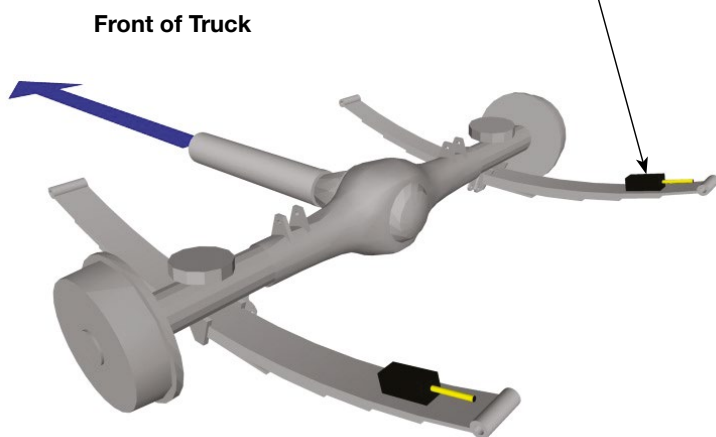

**Fig 1.26**

- When the transducers are installed on the rear of single axle leaf springs, as shown above (see figure 1.26), they are referred to as “leading”.
- Record the transducer orientation into the *Installation & Calibration Record* for entry into the meter during its setup.

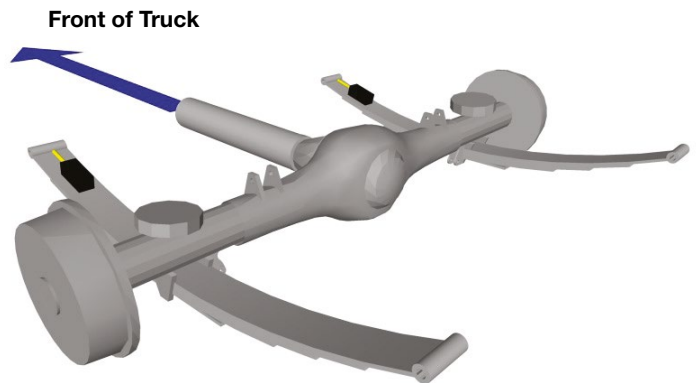
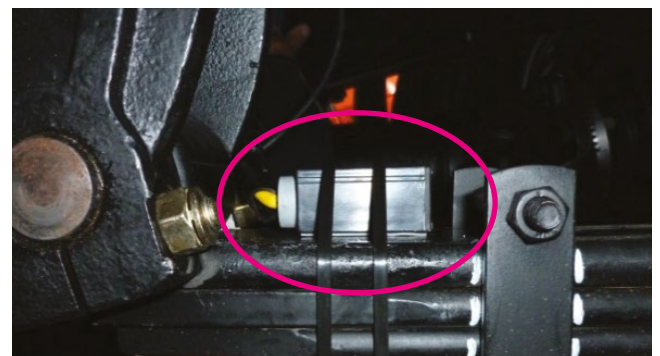

**Fig 1.27**

The TruckWeigh™ axle transducer may also be mounted at the front of the leaf spring as shown above.

- When the transducers are installed on the front of single axle leaf springs, as shown above (see figure 1.27), they are referred to as “trailing”.
- Record the transducer orientation into the *Installation & Calibration Record* for entry into the meter during its setup.

#### Transducer on a single axle spring (rear)



**Fig 1.28**

### Positioning of Transducers on Rear Steel Spring Bogie (Tandem Axle)

'Bogie' or 'tandem axle' (see figure 1.29)



Fig 1.29

Front of Truck

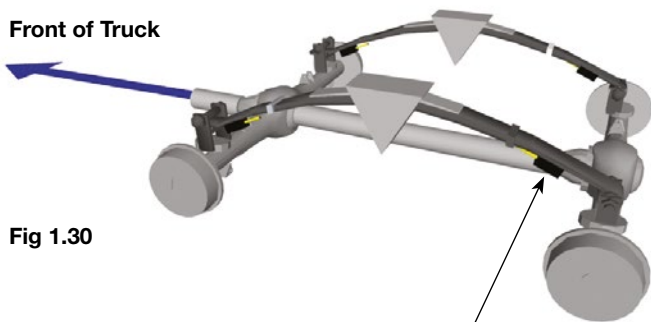
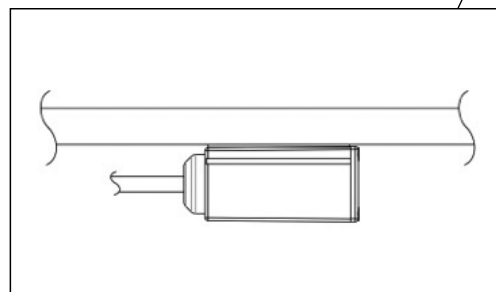

Fig 1.30



**Note:** Position of groove

The transducers are mounted on the underside of the leaf springs with the cables all facing the center of the bogie. In this example (see figure 1.30) the front transducers are referred to as 'leading'. The rear transducers are referred to as 'trailing'.

### Positioning of Transducers on Rear Hendrickson Rubber Bogie

'Bogie' or 'tandem axle' (see figure 1.31)



Fig 1.31

With Hendrickson rubber type rear suspension, mount the transducers on the torque arms.



Fig 1.32

The torque arms may be round or square.



Fig 1.33

The transducers are mounted with the cables all facing the center of the bogie (see figure 1.33).

You may mount the transducers under or on the sides of the torque arms (see figure 1.32) providing you observe that the groove indicating the top of the transducer is up and the transducers are as parallel with the chassis as possible.

### Axle Transducer Mounting

#### Points to consider

For effective adhesion of the transducer the following points need to be carefully considered:

- Location of the transducer site should be away from moving parts.
  - Mating faces need to be clean and dry.
  - The temperature of the surfaces should be above 60°F.
  - Pressure needs to be applied to bond the surfaces during initial installation.
1. The transducers need to be located sufficiently far away from any moving parts. The example below shows how much leaf springs and shackles move when a truck is full compared to when it is empty.

**Truck Empty**

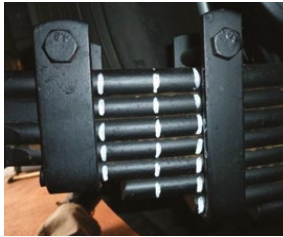

**Fig 1.34**

**Truck Full**

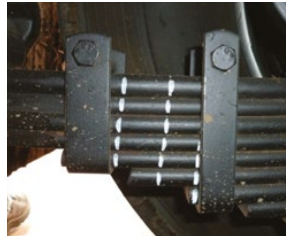

**Fig 1.35**

2. The transducer site must be thoroughly cleaned of all dirt and debris. If necessary any loose paint and rust must be cleaned down to bare metal. The site must be totally dry and the surface should be sanded prior to transducer installation. The following photos show each step of preparing the transducer site.



**Fig 1.36**

**Step 1**

Dirty and wet spring.



**Fig 1.37**

**Step 2**

Thoroughly clean the transducer site with a non-lubricant solvent cleaner.



**Fig 1.38**

**Step 3**

Clean off solvent and dry the transducer site.

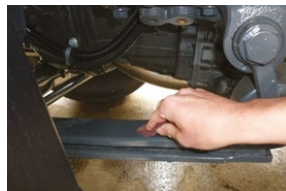

**Fig 1.39**

**Step 4**

Sand the area using maroon Scotchbrite.



**Fig 1.40**

**Step 5**

Clean the prepared area with the VHB surface cleaner, allowing the solvent to evaporate to leave a dry surface.



**Fig 1.41**

**Step 6**

Example of a properly prepared transducer site.

**3. Consider the temperature.**

- The ideal temperature for application is 70°F.
  - It is not recommended to fit the VHB tape at temperatures below 60°F.
  - Preferably fit the transducer to the springs in a workshop.
  - Where necessary, warm the spring with a hot air gun prior to bonding the transducer.
4. Pressure needs to be applied to make the adhesive contained in the VHB tape work.



**Fig 1.42**

After cleaning the transducer with VHB surface cleaner apply pressure to the tape using a roller.



**Fig 1.43**

Use a clamp to apply pressure to the assembly for 5 minutes.

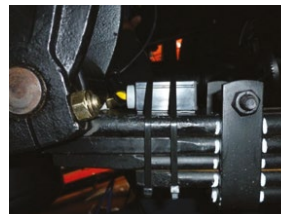

**Fig 1.44**

**And finally...**

Fit cable ties to provide mechanical support during the bonding time (100% bond in 72 hours). Cable ties can be left in place indefinitely. Movement of the vehicle during this time is acceptable.

**Tip:**

Identify the transducer's connector or its extension cable's connector with the location of the transducer so you can easily identify them when connecting to the junction box. The most commonly used method is to number them to match the numbers printed on the junction box label, i.e. 1 – Left front, 2 – Right front and so on. This could be done using an indelible marker or even a corresponding number of cable ties.



### Connect the Transducers to the Junction Box

When installing cables from TruckWeigh™ axle transducers to the junction box ensure you connect the transducers in the sequence as shown on the label of the junction box.



Mark each end of the interlink cable with the position of the transducer it connects to e.g.

- 1 = Axle 1 L/H Transducer
- 2 = Axle 1 R/H Transducer
- 3 = Axle 2 L/H Transducer
- 4 = Axle 2 R/H Transducer

Route the cables along the chassis with an existing cable run. Use cable ties to support the cabling.

- Ensure that cable to cable connections are well supported.
- Avoid running cables on or near sharp objects.
- Keep cables away from hot components such as exhausts and engines.

Connect each cable to its corresponding junction box and port number. Where a second junction box is used the port numbers are offset by 4.

- So...**
- Transducer 5 connects to port 1
  - Transducer 6 connects to port 2
  - Transducer 7 connects to port 3
  - Transducer 8 connects to port 4

As shown in the diagram below (figure 1.46).

Fig 1.45

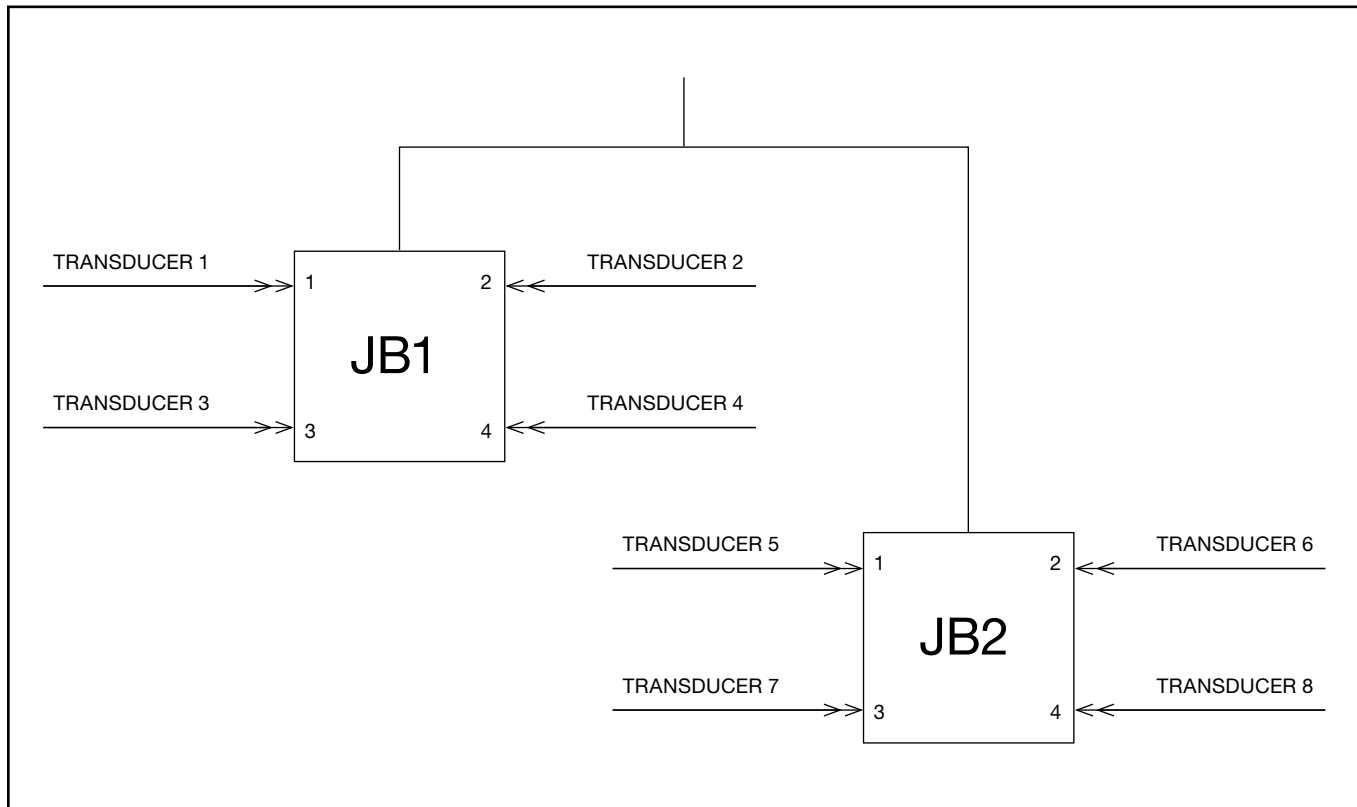

Fig 1.46

### Install the Chassis and Cab Cabling

Install the cabling to connect the junction boxes and air transducer interface boxes to the meter in the cab. When more than one junction box is used mark both ends of each signal cable so that each cable and therefore junction box can be identified at the meter. Use a Y Splitter Cable to connect each signal cable to the meter.

**Note:**

If you are installing a system on a semi-truck you will need to refer to the sections for installing the truck to trailer cable.



Fig 1.47

### Securing Excess Cable

For cables that are longer than they need to be you will need to loop them and retain them using cable ties.



Fig 1.48

**Step 1.**

If possible have the cable in a clear section of chassis.



Fig 1.49

**Step 2.**

Loop the excess cable back on itself to form a bundle and cable tie.



Fig 1.50

**Step 3.**

Add extra ties, tension and cut off excess.

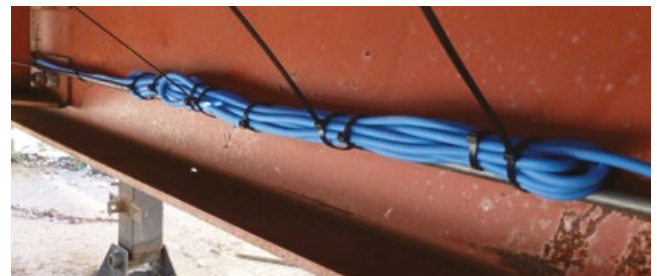

Fig 1.51

**Step 4.**

Now attach the cable bundle to a convenient support.



Fig 1.52

**Step 5.**

Tension the cable ties and cut off the excess.

## Optional Jumper Settings

### Power ON Jumper – JP1

If required by the customer, the meter can be made to power on when the ignition key is turned.

To open the meter and fit jumper JP1 on the PCB, remove the 4 Torx screws at the front of the meter and the 4 screws at the rear of the meter and slide out the PCB.

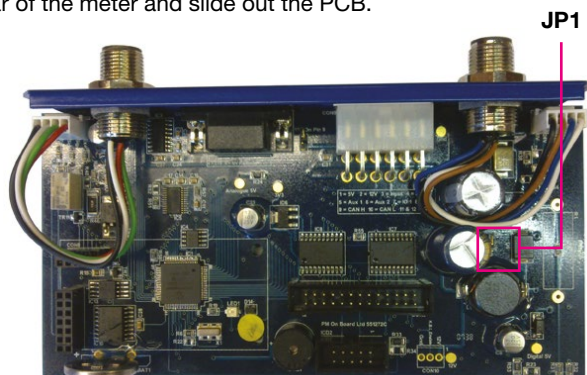

Fig 1.53

The location of “power on” jumper (JP1) is shown by the red box IN FIGURE 1.53.

Move the jumper so it will short the 2 pins of the header.

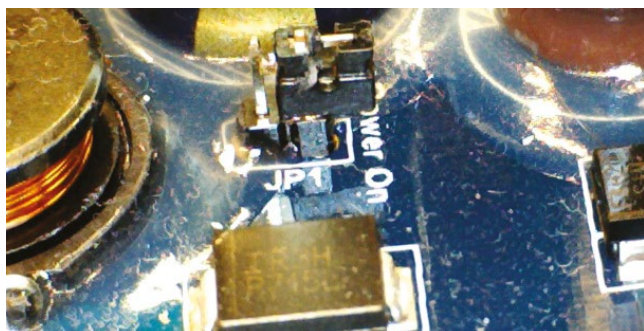

Fig 1.54

Header pins are open – meter power-up only after pressing the on button on the meter.

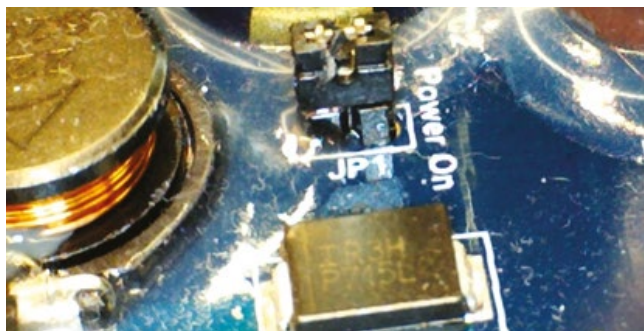

Fig 1.55

Header pins are shorted – meter will power up automatically with the ignition key.

Re-fit the PCB into the housing, re fit the rear screws and re-fit the front display panel.

## Serial Power On Pin 9

### Serial Power On Pin 9 – JP2

If required pin 9 of the D type connector can supply power to the peripheral device.

When jumper JP2 is closed power is available from pin 9 of the 9 way RS232 D type socket to drive a serial peripheral. This feature supplies a voltage of 12V DC with a current limit of approximately 150mA.

Follow the previous instructions to open the meter.

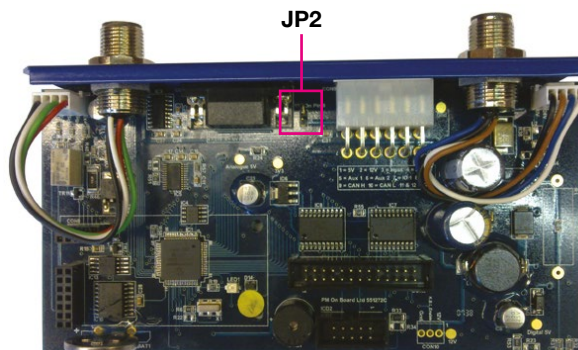

Fig 1.56

Figure 1.56 shows the location of jumpers JP2 (top center) on the PCB.

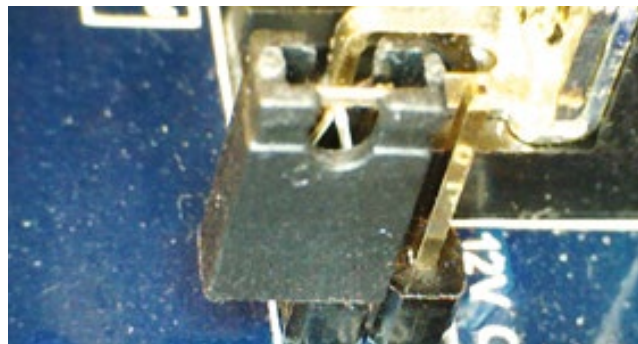

Fig 1.57

Figures 1.57 shows the jumper in the open position and located on one of the pins for storage – no power on pin 9.

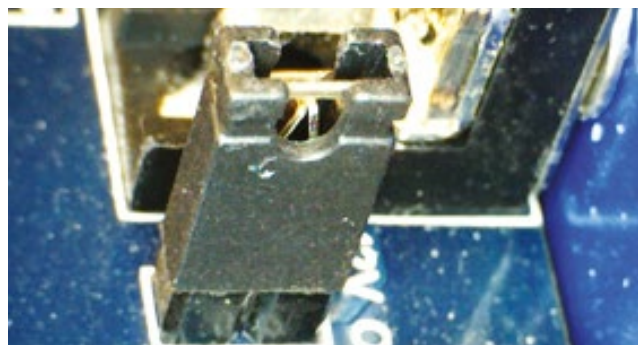

Fig 1.58

Move the JP2 onto both pins as shown in figure 1.58 -12V is now available on pin 9.



### Install the Meter in the Cab

#### Installing the Meter

There are two options for mounting the meter:

1. The meter is mounted in a standard single DIN/ISO radio slot in the dashboard.
2. Bracket mounted.

##### 1. DIN/ISO Slot Mounted.

With this method the display is mounted in a standard single DIN (Radio) slot in the dashboard.

All the connections are brought to the rear of the slot and connected to the display. The display is then pushed firmly into the slot, a click will be felt as the built-in security bracket engages.

##### To Remove

To remove the display from a DIN/ISO slot insert the two removal keys (notch facing downwards) into the two slots on either side of the display, just far enough to hook the notches over the fascia.

While pressing removal tools downwards pull the display free from the DIN slot.

##### Note:

These removal keys DO NOT work in the same manner as removal keys for the likes of car radios, which when pushed into their devices actually disengage the locking mechanism to allow the unit to be removed.

##### 2. Bracket Mounted.

This method uses a U-shaped mounting bracket to hold the meter to the dashboard or other suitable surface. Smaller brackets are also required to be installed to either side of the meter. The meter can be rotated to achieve the best viewing angle.

##### Note:

The meter should be located so it does not obscure the drivers view.

##### To Remove

Disconnect the connections, undo the two knobs holding the bracket to the meter and lift the display and small brackets clear.



DIN/ISO Radio slot

Fig 1.59

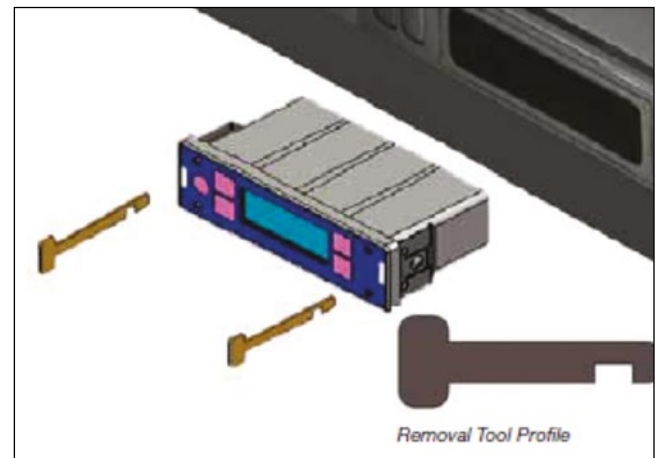

Fig 1.60

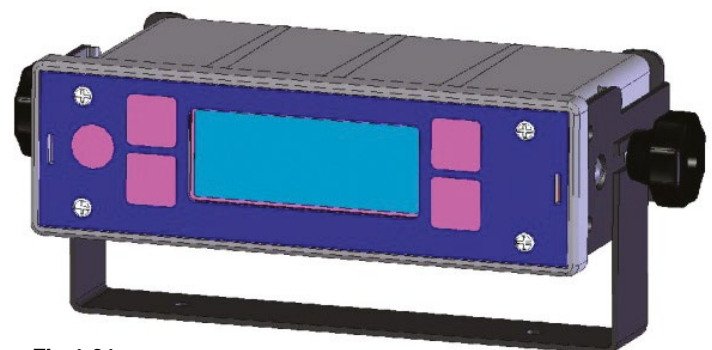

Fig 1.61

### Rear Connections

Various connectors are used on the back of the TruckWeigh™ meter. These are shown opposite:

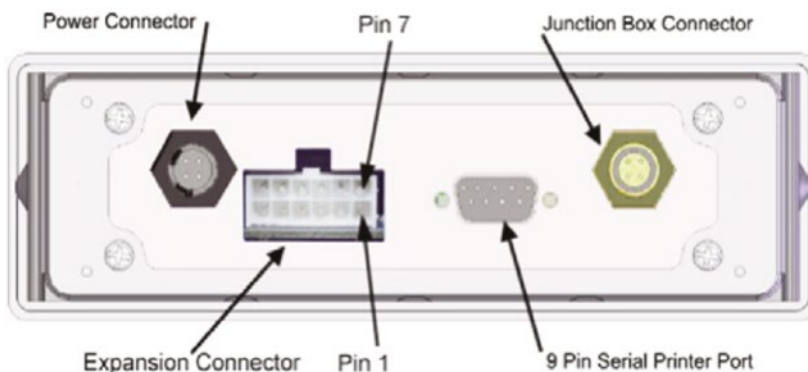

Fig 1.62

### Power Connection

Locate a suitable point to connect to the truck's 12V power supply. The meter would normally be powered from a power source that is on when the trucks ignition key is turned to the first position.

The power supplied to the meter must be protected by a 3A fuse.

#### Note:

The blue and white wires will be required if you are connecting the optional alarm, see below. If they are not used to feed an external alarm they must be terminated in such a way as to insulate them.

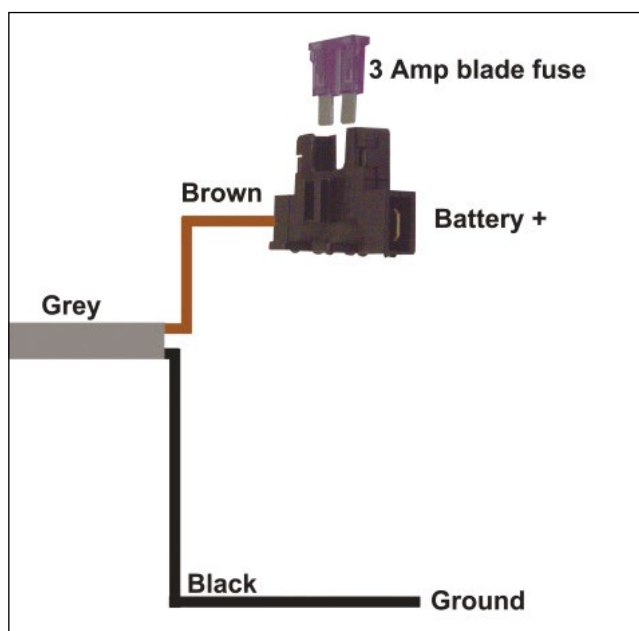

Fig 1.63

### Install External Alarm (Optional)

Fit the alarm in a location that provides some protection from dirt and rain but allows the alarm to be heard.

The alarm connects to the meter power cable as shown in figure 1.65.



Fig 1.64

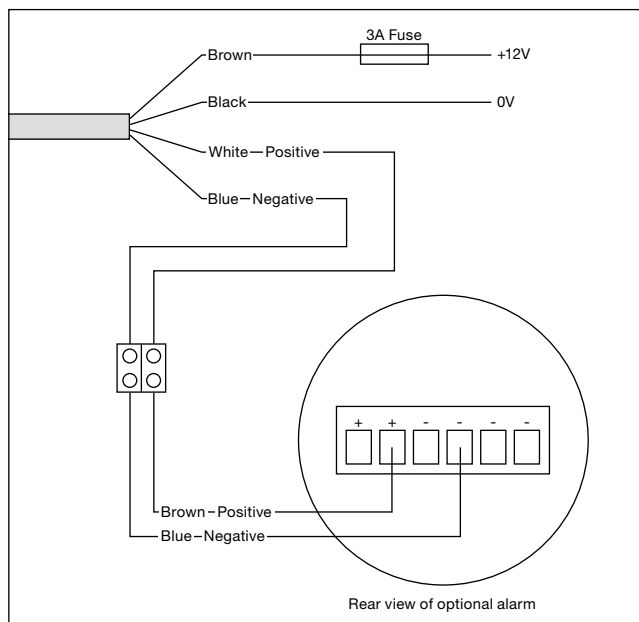

Fig 1.65

### Install Truck to Trailer Cable – Truck Side

Find a suitable location to fit the aluminum plate at the rear of the cab in the vicinity of the other truck to trailer cables and air pipes.



Fig 1.66

You will need to drill holes in the aluminum plate and use suitable screws and Nyloc nuts to attach it in the chosen location. It may be necessary to fabricate a bracket to mount the aluminum plate on to.

### Install Truck to Trailer Cable – Trailer Side

The trailer side of the truck to trailer will normally have its connector mounted in a similar location to the existing ones on the trailer and the cable route to the junction box or air transducer interface box will generally follow the existing lighting cabling along the trailers chassis rails.



Fig 1.67

Use 4 x 3/16" x 1" screws or longer if need be with 3/16" Nyloc nuts to mount the connector.

### Install 511 Transmitter (Optional)

The 511 is an optional hand held display that works using a radio link. The transmitter is normally located near the meter. The associated 511 receiver and its charge cable are also shown below.



Fig 1.68



Fig 1.69



Fig 1.70

The transmitter connects using a cable to the expansion port in the rear of the meter as shown in figure 1.70.

### Install Printer (Optional)



Fig 1.71

Connect the 9 way male D type connector of the printer cable into the rear of the display into the connector marked "RS232 port".



Fig 1.72

Plug the RJ11 into the printer.



Fig 1.73

Connect the power wires for the printer into the same connections as those that supply power to the meter – after the 3A fuse, red = +12V, blue = ground.

# Setup

### Introduction and Scope

Please read this setup manual completely before starting the meter setup so all areas are fully understood.

#### Introduction

TruckWeigh™ is a vehicle payload optimization, overload protection and load distribution system for use on vehicles with steel spring or air suspension, or a combination of the two.

#### Scope

This manual is intended as a guide to the setup of TruckWeigh™.

It is only concerned with the two currently supported sensor types for use in a TruckWeigh™ system:

- TruckWeigh™ axle transducers that measure suspension deflection for use on mechanically spring suspension systems.
- Air pressure transducers for use on air suspension systems.

In order to support known chassis configurations various system options can be configured using either of the above sensors, or combinations of the two.

Any display screenshots used in this document are intended as an illustration of the menu function being described, as such any specific detail or settings shown will differ from one installation to another.

#### Attention:

The TruckWeigh™ indicator has a certain amount of legacy functionality available through its menu structure which is not considered to be a part of the TruckWeigh™ program, hence is not supported and falls outside the scope of this manual.

#### Important Notes:

There are areas of this procedure that are of particular importance to ensure a reliable and properly functioning system and these are covered in detail in the manual:

- TruckWeigh™ axle transducer installation and configuration – suitable location and orientation for the transducer should be carefully identified and that location should then be prepared for the transducer to be attached. Slope compensation should also be set accordingly.
- Span calibration – it is important that this is carried out with each axle loaded as close as possible to its maximum rated weight. PI% values should also be verified.
- These are the sensors calibration values. They are only valid after span calibration and work in sensor pairs, i.e. both left and right sensor for each axle should have the same value. These figures should be checked on level ground.

The tables below show approximate example values for reference:

#### Axle Transducers

Angle – both axle sensors	PI value	PI % ratio	Axle net span weight lbs
2°	8192	50 %	3000
2°	16384	100 %	6000
2°	32768	200 %	12000
2°	40960	250 %	15500
3°	8192	50 %	2600
3°	16384	100 %	9200
3°	32768	200 %	18500
3°	40960	250 %	23100

#### Air Transducer

Air transducer output Volts (both left and right channels)	PI value	PI % ratio	Axle net span weight lbs
1.0 V	8192	50 %	5000
1.0 V	16384	100 %	10000
1.0 V	32768	200 %	20000
2.0 V	8192	50 %	16000
2.0 V	16384	100 %	32000
2.0 V	32768	200 %	64000
3.0 V	8192	50 %	23800
3.0 V	16384	100 %	47600
3.0 V	32768	200 %	95000

- Any meter setting not mentioned in this manual should be left at default unless another VPG On-Board weighing document or instructed by our service engineers.



## Front Panel Functionality

The various screens and menus are accessed by using the four buttons located around the LCD display, described briefly below:

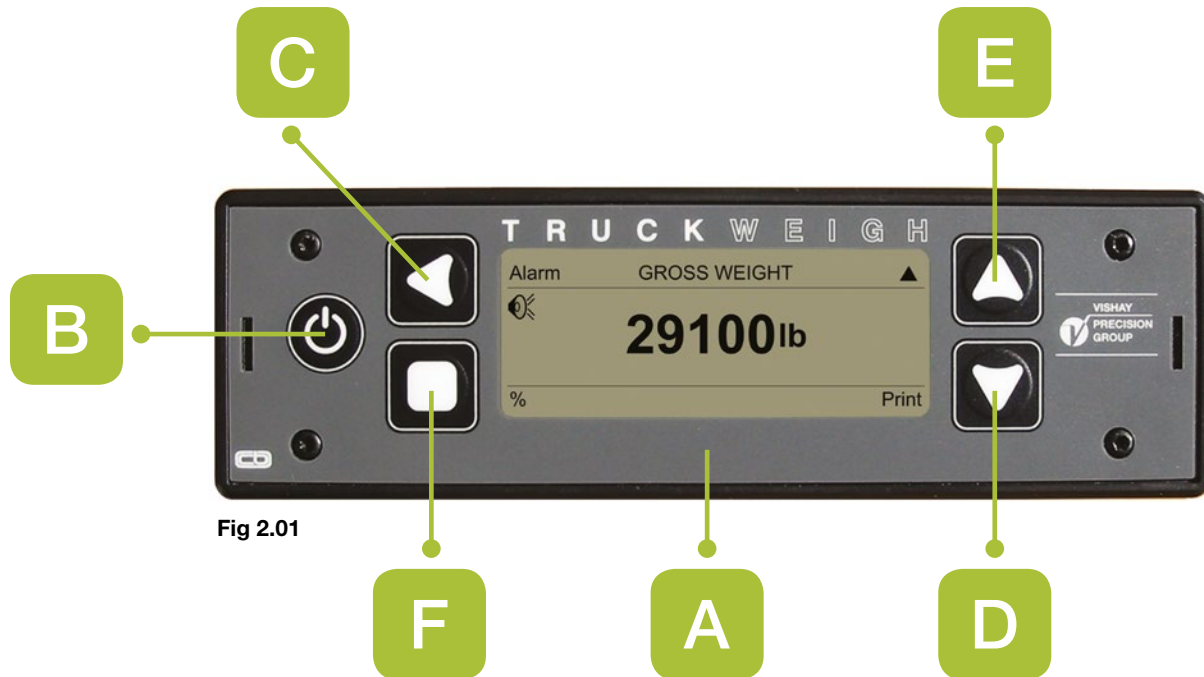

Fig 2.01

### A - LCD DISPLAY

Displays currently selected information, i.e. Gross Weight, Net Weight, Axles or menu.

The four buttons located around the LCD display each have their own functions that carry through most screens but there are some screens where they invoke different operations. In every screen there is an indication as to what each button does located in the adjacent corner of the screen, if there is nothing displayed then that button is not currently active.

### B - ON/OFF BUTTON

Located to the far left of the display with a circular symbol broken at the top by a vertical line, it is used to switch the display on and off. If the Power-On jumper option is enabled, this button will have no function.

### C - LEFT ARROW BUTTON

Located to the upper left hand side of the LCD display with a left facing arrow symbol, it is generally the alarm, select/accept and edit button.

### D & E - UP AND DOWN ARROWS

Located to the upper and lower right hand side of the LCD display with respective up and down facing arrow symbols, these are generally used to scroll the cursor up and down lists and screens, or increase and decrease numbers.

### F - EXIT BUTTON

Located to the lower left hand side of the LCD display with a square symbol, it is generally the exit button.

### Power Up the Meter for the First Time

Power the meter on. If the meter asks “New JBox/Trailer swap detected please confirm” press “No”.

### Entering the Setup Menu

Enter the setup menu by pressing the “up” button until you see “Menu” on the top left of the screen. Press the “Menu” key, then scroll the cursor down to “Setup” and select it.

You will most likely be asked to enter a PIN number. The default PIN is 7711, enter this number as explained on the previous page. Do not give the PIN to truck drivers. You can change the PIN if needed. This will be explained later.

### Changing a Parameter Value

Where an on-screen parameter has to be changed then a standard method can be used to make the required change. This method applies across all setup screens in the meter.

A typical example is shown below.

### How to change a parameter value

The selected parameter is shown by the long grey bar on the parameter and value.

The value shown in Fig.2.02 is 5500lb.



Fig 2.02







1. To change this press button  (edit). This will clear the long bar and highlight the first changeable value, as shown in figure. 2.03.
2. Use buttons  &  to alter the original value to the required value.
3. To move to the next value in line press  and repeat as for line 2.
4. Once the required value is fully changed press button , this will show the new value.
5. Press button  again to leave the screen.



Fig 2.03

**Note:**

After editing any parameter it is essential to exit back to the user screen as it saves the settings during exiting the menus.

### Obtain the Truck's GVWR and Axle Ratings

Locate the truck's rating plate and record the maximum gross axle weights and the truck's maximum Gross Vehicle Weight Rating (GVWR) and record these figures on the TruckWeigh™ Installation and calibration record sheet.

In the case of trailers the axle ratings are normally on a trailer chassis mounted plate.

Vehicle Specific Information	Axle	Plated Gross Weights (lbs)	Suspension Type	
			Air	Mech
Chassis Make/Model:	1			
Chassis Configuration:	2			
Body:	3			
Customer:	4			
Reg/Fleet No:	Vehicle			

Fig 2.04

### Junction Box Configuration - Overview

The system is designed to work in a variety of different system combinations and as such it may be necessary to configure the junction box(es) accordingly.

The sensor numbering assumes they are always in pairs. Single input air transducer interface boxes will report themselves as 2 sensors, giving the same reading for left and right.

Figure 2.05 would represent the top view of a 4 axle steel suspension straight truck and how the TruckWeigh™ axle transducers would be numbered:

This numbering convention can also be applied to any configuration.

Note: Where a group of axles share a common air suspension circuit, only one CAN Air junction box is required and TruckWeigh™ will treat these as one axle (referred to as an Axle Group).

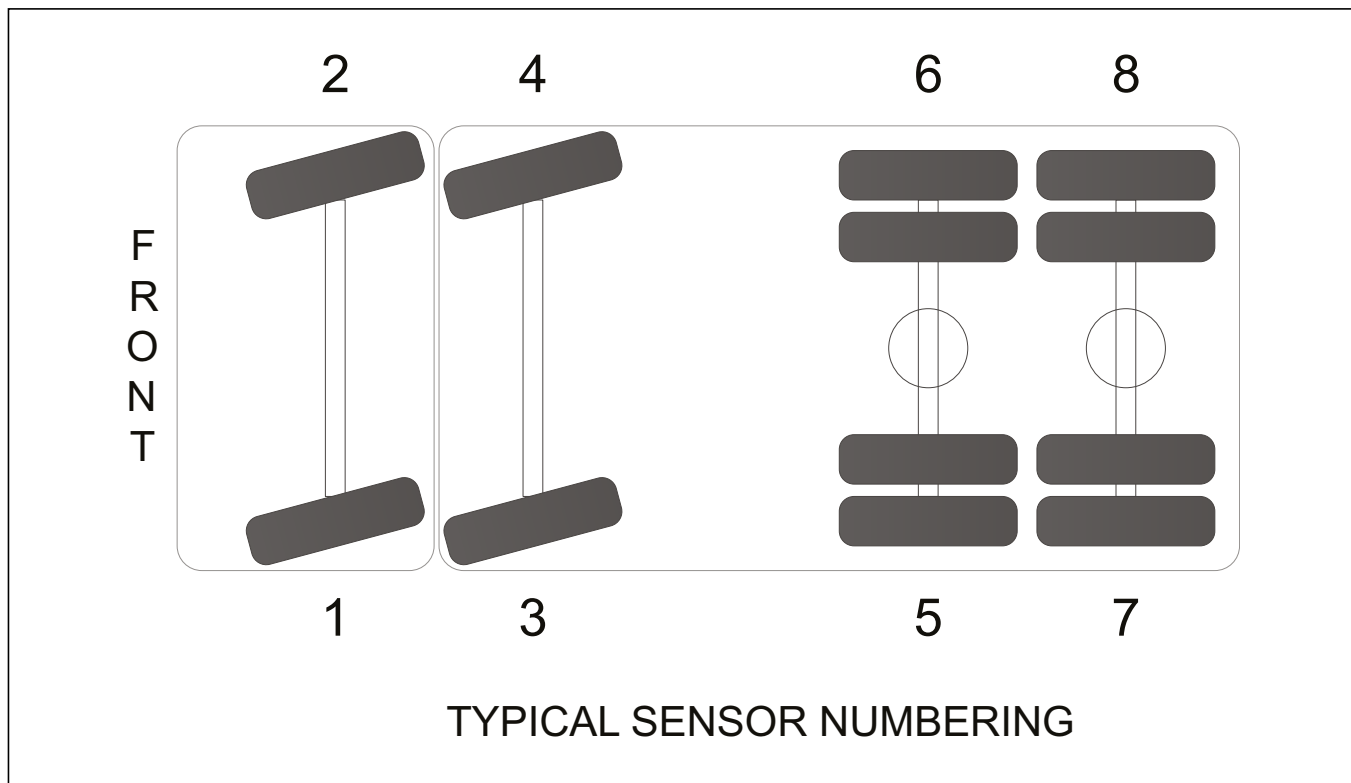

Fig 2.05

### Junction Box Configuration – Examples

Below is a summary of CAN junction box/air transducer interface box modes. Sensor numbers in brackets refer to additional sensors when a 6 way junction box is used. The sensor number refers to the orientation shown in figure 2.06.

Mode	Sensors	Junction box/air transducer
0	1,2,3,4,(5,6)	4 or 6 way CAN junction box
1	1,2	4 way CAN junction box or air transducer
2	3,4	4 way CAN junction box or air transducer
3	5,6	4 way CAN junction box or air transducer
4	7,8	4 way CAN junction box or air transducer
5	5,6,7,8	4 way CAN junction box
6	3,4,5,6,(7,8)	4 or 6 way CAN junction box
7	1,2,5,6	4 way CAN junction box

Fig 2.06

A 4 or 6 way CAN junction box will be set to mode 0 when new. An air transducer interface box will be set to mode 1 as supplied new.

Refer to Appendix A for examples of particular setups for various truck types.

### Junction Box Configuration

Turn the meter off.

Ensure that signal cables are NOT connected to any junction box or air transducer interface box.

Axle Transducers and Air Transducers may remain connected to their corresponding junction box.

Turn on the power to the TruckWeigh™ meter and enter the “Setup” menu as previously described.

Select “Vehicle Config.” Then scroll the cursor down to “JBox Config” and select it. You will see the screen shown below:

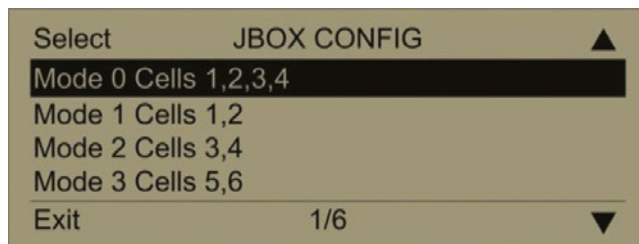

Fig 2.07

Plug in the first CAN junction box or air transducer interface box you wish to configure.

Scroll the cursor down to the mode you wish to configure the item to. Press the “Select” button.

You will be prompted “Are you sure? Yes/No”. Press “Yes”.

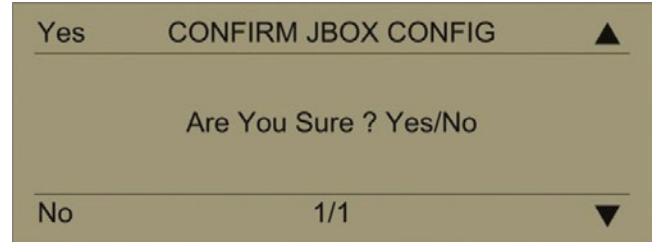

Fig 2.08

You should see the following screen to confirm it has configured OK:

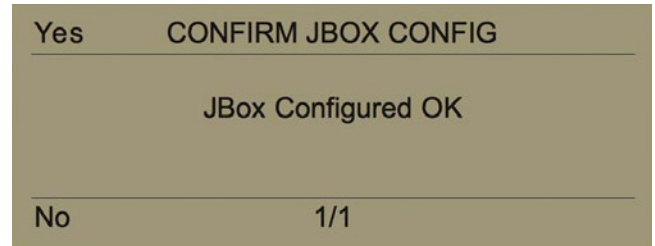

Fig 2.09

Un-plug that CAN junction box or air transducer interface box and if required connect the next one to be configured.

Repeat the above steps from the line “Scroll the cursor down” for all the remaining CAN junction boxes or air transducer interface boxes that need configuring.

Once you have configured the last CAN junction box or air transducer interface box, press “Exit” 4 times to return to the user weighing screen. At this point it will be normal to see a warning message “Error! CAN Bus Fault”. Turn the meter power off.

Re-connect all the CAN junction boxes and air transducer interface boxes.

Turn on the power to the meter and ensure all the junction boxes and transducers that are connected are reported during the power up sequence, similar to the screen below.

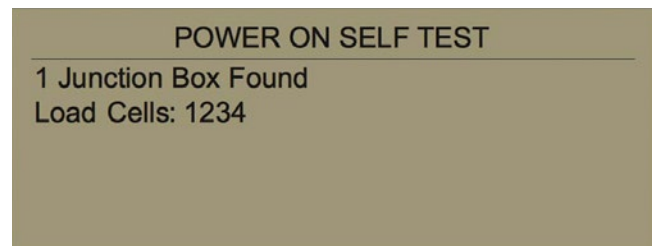

Fig 2.10

Record the junction box and air transducer interface settings you have just completed on the *Installation and Calibration record* sheet, in the System Configuration section as illustrated on page 29.

Vehicle Specific Information							Slope Compensation	
Junction Box	4 Way CAN	6 Way CAN	Dual CAN Air	Single CAN Air	Mode	Bogi Position	Trailing (T), Leading (L), Fixed (F) or None (N)	
1								
2								
3								
4								

Fig 2.11

## Set the Number of Axles and Check the Weigh Mode

Access the Setup menu as previously described and select the “Vehicle Config” option.

Check that “Weigh Mode” is set to “Multi axle”. If it requires changing scroll to Weigh Mode and press the Edit button to cycle through the available options until “Multi-Axle” is displayed.

Scroll the cursor down to select the “Number of Axles” item and using the Edit button, cycle through the available options of 2, 3 and 4 as required for the vehicle. Note: air axle groups count as 1 axle. An air group is two or more axles that share a common air circuit.

Press exit 3 times to return to the main weighing screen and cycle the meter power off and on.

## Set the Meter’s Time and Date

Access the Setup menu as previously described and select the “Set Time/Date” option. Use the edit keys to edit the values as previously described.

The “Select” button will change the item you are editing.

Press “Exit” and when prompted to confirm press “Yes” to confirm setting the time/date.

Press “Exit” twice to exit to the user weighing screen.

## Set the Overload Alarm Set Points

There are overload warning alarms for: Gross vehicle weight, Net weight and for individual axle gross weights.

The alarms are normally set to the GVWR figure on the trucks rating plate for both the overall truck gross weight and each individual axle gross weight.

Access the Setup menu as previously described and select the “Alarms” item.

In this screen you can edit each alarm set point individually. Use the edit keys to edit the values as previously described.

At the top of the Alarm menu there is a setting “Alarms” that can be set to Manual or Auto. In the event of any active alarm being silenced by the user, this setting dictates the method for resetting that alarm:

- Manual – alarm will need to be manually reset by the user before it becomes active again.
- Auto – alarm will automatically reset when the weight in question falls below 50% of the alarm set point.

At the bottom of the alarm menu there is a setting “Alarm filter”. The purpose of this is to prevent false alarm triggering. The weight must exceed the alarm set point for that number of seconds before the alarm actually sounds.

Press “Exit” three times to exit to the user weighing screen.

### Set the Slope Compensation

The correct setting of this parameter is critical for the reliable operation of the system.

Referring to the Installation and Calibration Record Sheet, the installer should have recorded “leading”, “trailing” or “none” for each relevant axle.

If for some reason the installer has not recorded the information, you should refer to the installation manual and check the mounting position of the TruckWeigh™ axle transducers so you can set the slope compensation correctly.

Figure 2.12 illustrates the basic difference between leading and trailing relative to the junction box position.

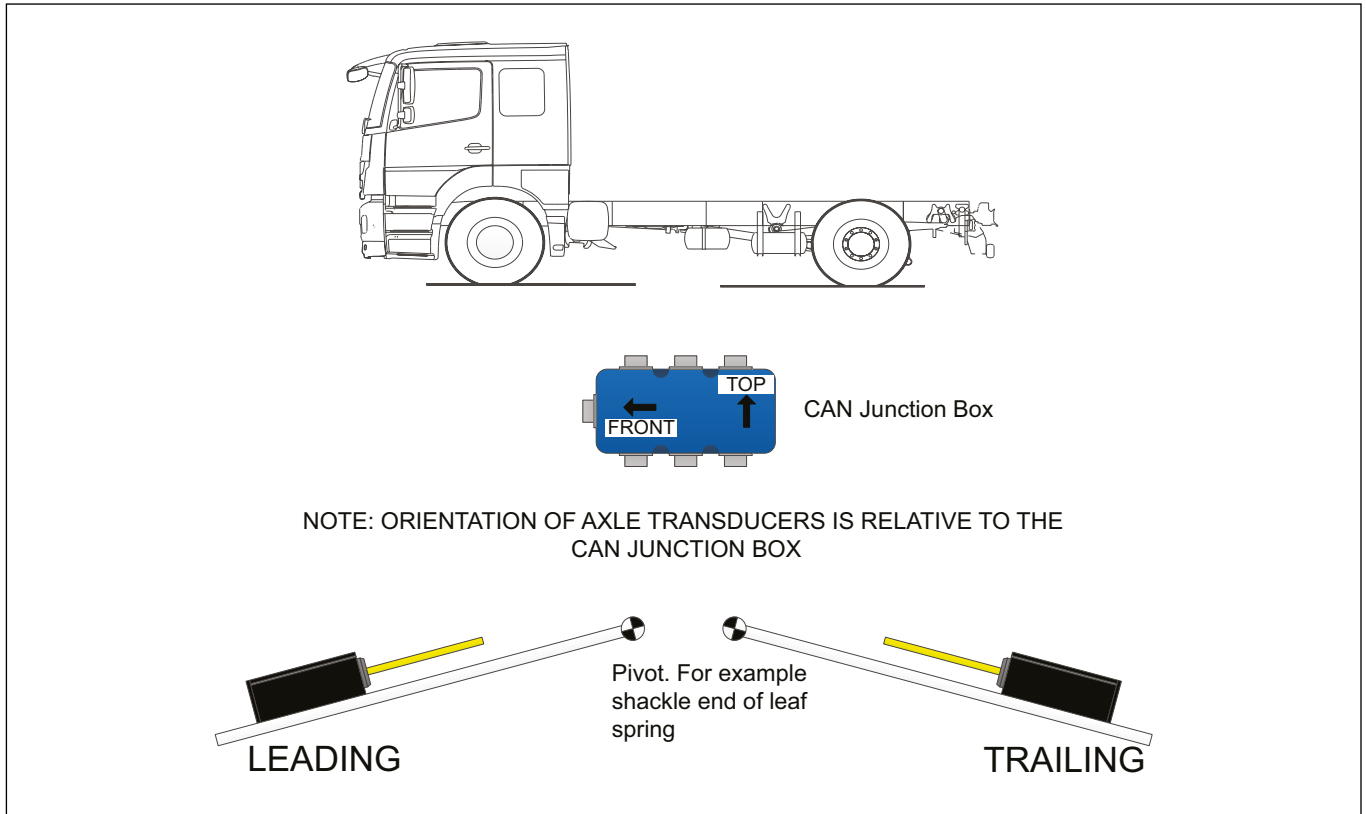

Fig 2.12

Enter these settings as described below.

Access the setup menu as previously described and select the “Vehicle config” option.

Scroll the cursor down to the “Slope Compensation” item and press “Edit” to select it.

Scroll to each relevant axle in turn and using the select button cycle through the options – Leading, Trailing, None – until the desired value is displayed.

Press “Exit” four times to return to the main user weighing screen.

**NOTE 1:** Any axles with Air transducers installed will default to “None” and are not configurable.

**NOTE 2:** Although uncommon, a setting of “None” may be applied to an axle when the transducers are mounted perpendicular to the vehicle chassis, for example on the wishbone of a McPherson strut type setup.

Select	GRADIENT COMP.	■
Axle 1	Leading	■
Axle 2	Leading	■
Axle 3	Leading	■
Axle 4	None	■
Exit	1/4	■

Fig 2.13



### Configure Tandem Axle (Bogie) Mode

Tandem axles must be configured when the truck has suspension similar to the two types shown in Figs. 2.14 and 2.15.



**Fig 2.14** Steel spring bogie



**Fig 2.15** Hendrikson rubber suspension

The two types of tandem axle suspension shown above are referred to in this manual and in the meter menus as “Bogie”. Access the setup menu as previously described and select the “Vehicle config” option.

Scroll the cursor down to the “Bogie Position” item and press “Edit” to change it.

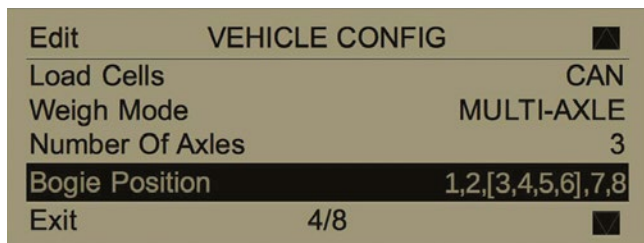

**Fig 2.16**

This works by putting square brackets around the TruckWeigh™ axle transducer numbers that are on the bogie.

Ref	Bogie on weighed axle #	Meter shows this as on the screen
1	1 and 2	[1,2,3,4],5,6,7,8
2	2 and 3	1,2,[3,4,5,6],7,8
3	3 and 4	1,2,3,4,[5,6,7,8]
4	1 and 2 also 3 and 4	[1,2,3,4],[5,6,7,8]

**Fig 2.17**

By axle number, this means the axles that have TruckWeigh™ axle sensors installed counted from the front of the truck.

**Example 1.** The truck in figure 2.18 has all 4 axles weighed using TruckWeigh™ axle transducers:



**Fig 2.18**

From the table above select Ref 3 – shown on the meter as “1,2,3,4,[5,6,7,8]” - meaning the bogie is on the 2 rear most weighed axles.

**Example 2.** The truck in figure 2.19 has the drive and trailer axles weighed using TruckWeigh™ axle transducers (no weighing on the steer axle). It has Hendrikson rubber suspension for the drive axles and steel spring bogie on the trailer:



**Fig 2.19**

From the table above select Ref 4 – shown on the meter as “[1,2,3,4],[5,6,7,8]” - meaning the bogies are on the drive axles and on the trailer axles.

When counting the axles the system is not aware of the steer axle as it has no weighing sensors, so as far as TruckWeigh™ is concerned axle 1 is the first drive axle as it is the furthest forward of the weighed axles.

### Tag Axle – Overview

If the truck has air suspension with a tag axle that can be raised or have the weight removed from it either manually or automatically the tag axle manager should be used.

The tag axle manager is used to manage a tag axle in an air group. It handles the correct weight display according to whether the tag axle is up or down. There is a difference made here between a single air tag axle and a tag axle in an air group.

Figure 2.20 is an example of a rear air group axle. Note that one air junction box is used for both rear axles. This is what forms the air group. One air junction box connected to more than one axle, one of which is also a tag axle.

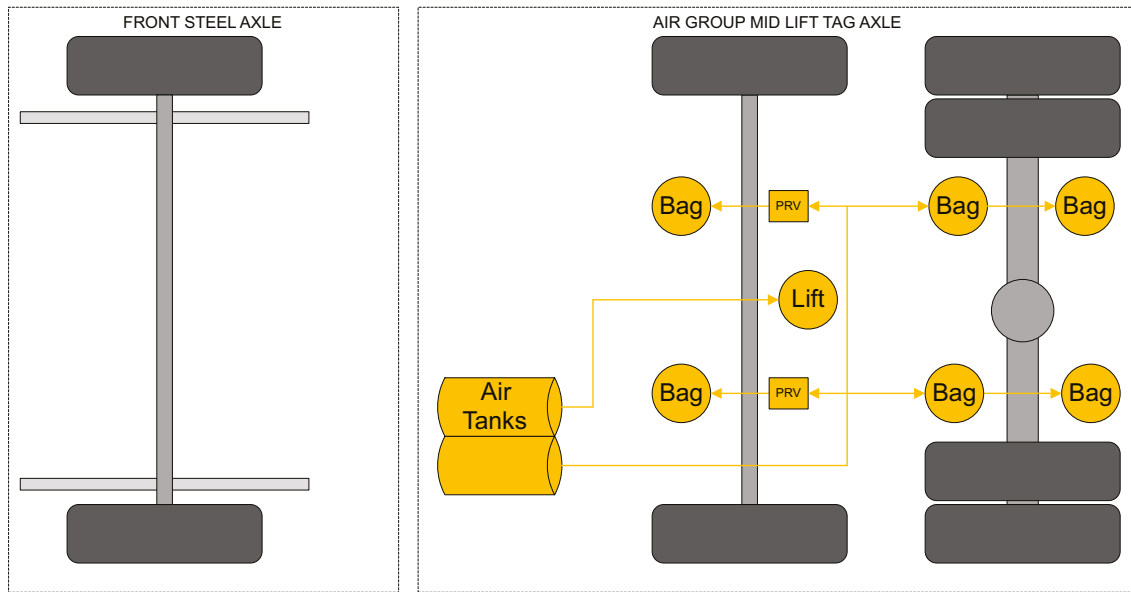

Fig 2.20

The air group manager should only be used in situations where a tag axle is a part of an air group. If the air junction box is only connected to a single tag axle then this does not require the tag axle group manager to be enabled. See figure 2.21.

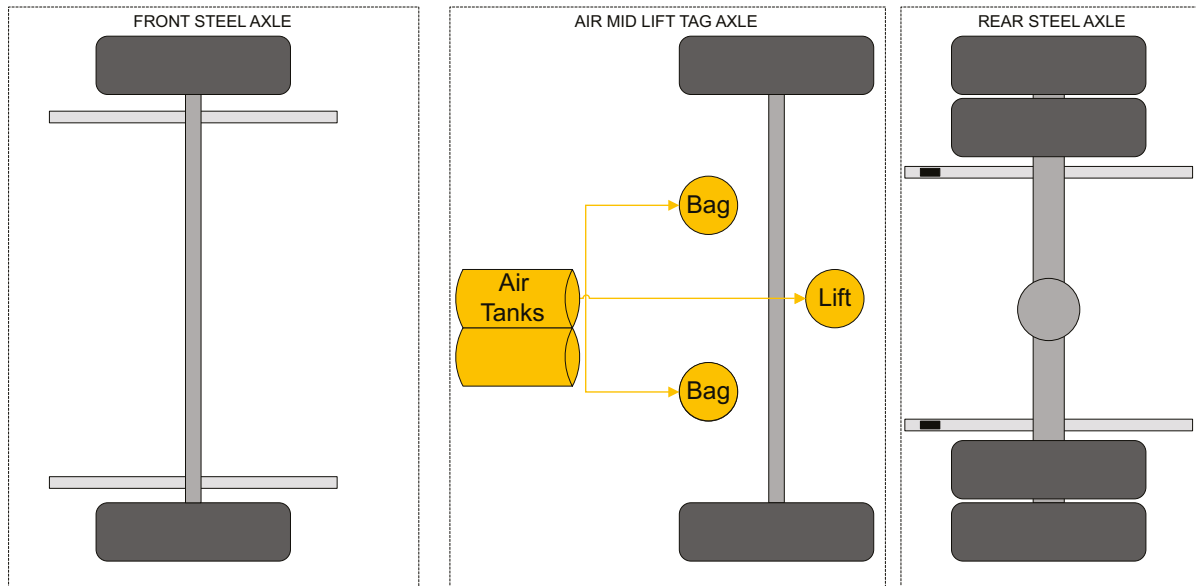
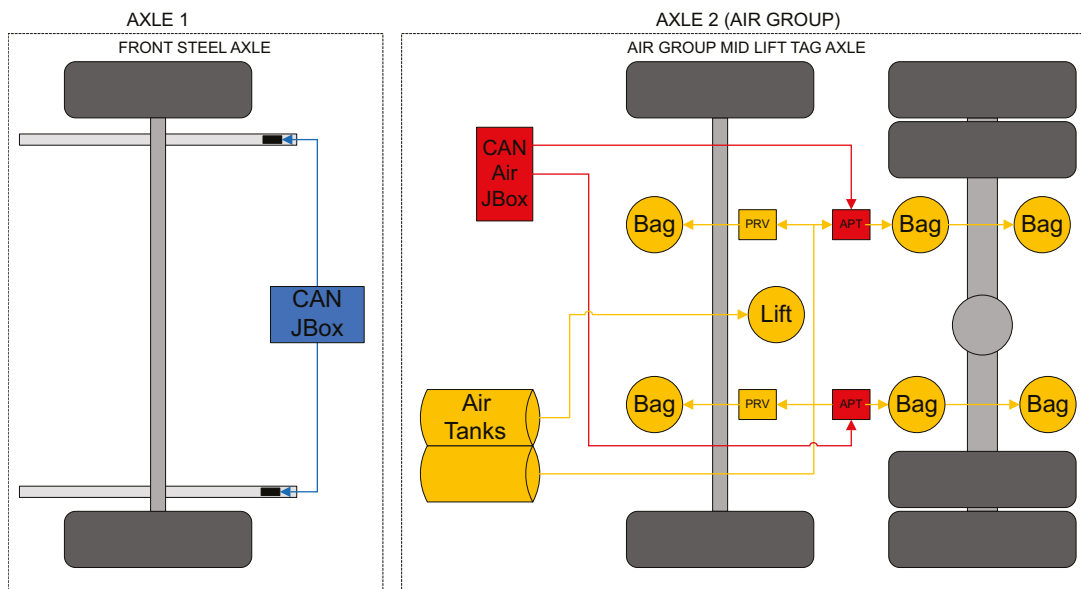

Fig 2.21



Tag axle group position means which air transducer group has the lift axle in it.

In the example below axle group 2 has the lift axle, so “Tag group position” would be set to 2.



**Fig 2.22**

Figure 2.23 and figure 2.24 show the options within the Tag Axle Config screen.

If you are required to setup the tag axle manager, it MUST be left OFF until after the truck has been calibrated.

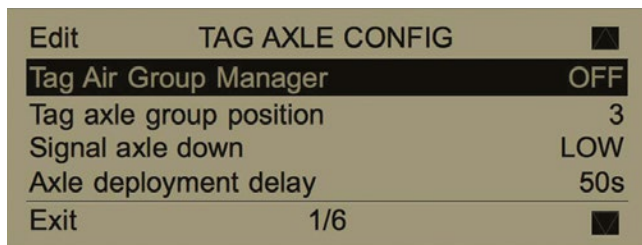

**Fig 2.23**

The actual configuration of the tag axle manager is explained fully in the next section.

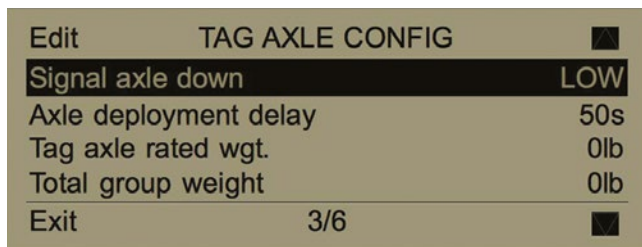

**Fig 2.24**

The signal into the rear of the meter should have been connected by the installer. The installer may have written on the *Installation and Calibration Record* which way the signal operates (axle down = 0V or axle down = +12V). If not or you need to verify they have done it correctly you can check this in the case by looking in the diagnostics menu.

Press “Up” until you see “Menu” on the top left. Select “Menu” then select “Diagnostics”.

Now press the down button 3 times. You should see the “External inputs” screen.

Make the tag axle raise and fall and you should see “Input 1” change. Record which axle position relates to what signal – for example axle lowered = signal low (0V) or axle lowered = signal high (+12V).

Axle position	Input 1 (Diagnostics)	
Raised	High	Low
Lowered/Signal Axle Down	Low	High

**Fig 2.25**

### Configure Tag Axle – if Required

Access the setup menu as previously described and select the “Vehicle config” option.

Scroll the cursor down to the “Tag Axle Group Config.” item and press “Edit” to enter the menu.

Leave the first item “Tag air group manager” set to off. Scroll the cursor down to the next item.

Set the “Tag axle group position” as per the explanation in the previous section. Scroll the cursor down to the next item.

Now set the “Signal axle down” setting based on the check explained in the previous section. As explained above the signal can be low (0V) or high (+12V) for axle down.

The “Axle deployment delay” defaults to 50 seconds. It delays the effect of the change of weight value that is brought about by the signal that means “axle down”. The purpose of it is to stop any transient signal “spikes” triggering the axle down detect.

It is recommended that you leave this setting at its default setting.

The “Tag axle rated wgt.” Is figure taken from the trucks rating plate for the tag axle.

The “Total group weight” is the rating of all the axles in the air group added together. In diagram fig 2.22 in the previous section this would be the figure of both axles in the dotted area “Axle group 2” added together.

Now press “Exit” 4 times to return to the main user screen.

### Configure Optional 511 transmitter



**Fig 2.26**

A 511 transmitter

If the truck has a 511 transmitter it will need to have the CAN output enabled and the 511 channel set

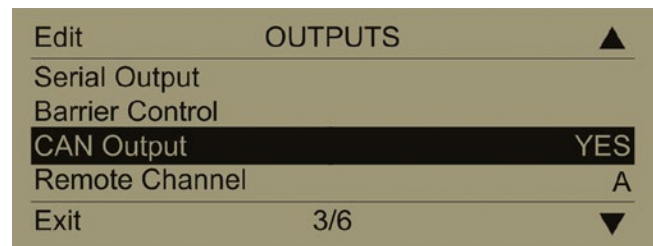

**Fig 2.27**

Access the setup menu as previously described and select the “Outputs” option.

Scroll down the cursor to the “CAN output” item and press “Edit” to change it to “Yes”.

If required, scroll the cursor down to ‘Remote Channel’ and change it. If a number of trucks operate in close proximity to one another, each truck will need to be set to a different channel. The same channel needs to be set on each truck and its corresponding 511 hand held remote.

Now press “Exit” 3 times to return to the main user screen.

## Configure Optional Printer

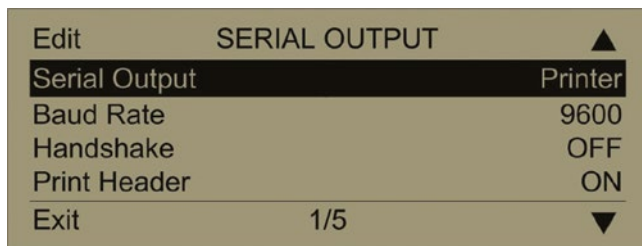

**Fig 2.28** Thermal printer

If a thermal printer is installed there is one setting that will need to be changed from default for it to operate correctly.

Access the setup menu as previously described and select the “Outputs” option.

Press “Edit” to select serial output.  
You should see the menu below:



**Fig 2.29**

Scroll down the cursor to the “Handshake” item and press “Edit” to turn it on.

Now press “Exit” 4 times to return to the main user screen.

## Record the Firmware Versions and Other Details

Complete the remaining items in the *Installation and Calibration Record* down as far as but not including the calibration data.

## Set the Manager and User PINs

Access the setup menu as previously described and select the “PIN Access” option.



**Fig 2.30**

Select the top option “Set Manager PIN” and change this to a number agreed with, or to be given to, the customer’s management or maintenance staff.

Scroll the cursor down to the “Set User PIN” item. Select it. Change this to a number agreed with, or to be given to, the customer’s management or maintenance staff. Make sure they are clear that the user one may be given to the driver if they are allowed to change alarm set points.

If the owner of the truck does not want the driver to be able to change anything they should not tell the driver any of the PIN numbers.

If a customer cannot remember their PIN number they can contact VPG On-Board Weighing who can provide a one-off emergency code to allow the manager or maintenance staff to access the menus and change it.

If the truck is driver-owned you should leave the PIN control set to OFF unless the driver wants it on to prevent un-authorised tampering.



# Calibration

### TruckWeigh™ Calibration Process

Please read and understand the entire calibration process before proceeding.

#### Prerequisites

Calibration should only be carried out after all previous steps of installation and setup have been successfully completed. It should ideally be done on flat, level ground on a calm day, even indoors if possible.

It is essential that the calibration process is carried out in a specific order that will be detailed in this manual, summarized as follows:

- 1. Zero Inclometers**  
Sets the reference point for the Junction Box and TruckWeigh™ Axle Transducers, completed with an empty payload.
- 2. Zero**  
Sets the tare point for the system, completed with an empty payload usually immediately after Zero Inclometers.
- 3. Axle Spans**  
Sets the Span point for the system, completed with a full payload, ideally as close to GVWR as is possible.

### Weighing the Vehicle

Calibration requires that each of the individual axles of the vehicle be weighed. The process is the same when empty or full. This can be achieved using either of two methods:

#### 1. Weigh Pads Method

Ideally 1 pair of weigh pads per axle is required, i.e. 2 axles: 4 weigh pads, 3 axles: 6 weigh pads, etc.

If only 1 pair of weigh pads is available leveling mats should be used under all other un-weighed axles in order to maintain the overall level of all axles.



Fig 3.01

#### Very Important:

If using weigh pads, the axle figure is calculated by adding together the readings from **both** weigh pads beneath that axle.

#### 2. Weighbridge Method

The measurement of each axle on a weighbridge can be done by driving the vehicle on or off the weighbridge one axle at a time and noting the readout in each case. The weight for each axle can then be calculated by simple subtraction of each previous figure as shown in the example below (this will vary depending upon the number of axles).

#### Note:

The Weighbridge must have a level approach. This would normally mean a pit type weighbridge as shown opposite:



Fig 3.02

	Payload								Axle Spans = Full - Empty
	Empty				Full				
	Weighbridge	Axle			Weighbridge	Axle			
Vehicle Weight	<b>W</b>	9000			<b>W<sup>2</sup></b>	18000			
Axle 1	<b>A</b>	7500	<b>E=W-A</b>	1500	<b>A<sup>2</sup></b>	15500	<b>E<sup>2</sup>=W<sup>2</sup>-A<sup>2</sup></b>	2500	1000
Axle 2	<b>B</b>	6000	<b>F=A-B</b>	1500	<b>B<sup>2</sup></b>	13000	<b>F<sup>2</sup>=A<sup>2</sup>-B<sup>2</sup></b>	2500	1000
Axle 3	<b>C</b>	3000	<b>G=B-C</b>	3000	<b>C<sup>2</sup></b>	6500	<b>G<sup>2</sup>=B<sup>2</sup>-C<sup>2</sup></b>	6500	3500
Axle 4		7500	C	3000			<b>C<sup>2</sup></b>	6500	3500
				9000			Total	18000	9000

Fig 3.03

### Procedure

1. With an empty payload weigh the vehicle using either of the previously outlined methods. Calculate the individual axle weights in each case.
2. With the vehicle positioned on flat, level ground, on the meter select:

#### a. Axle Tares

Menu > Setup > Vehicle Config > Axle Tares and edit each axle as required, entering the calculated tare weights.

Edit AXLE TARES	
Axle 1	11000lb
Axle 2	11000lb
Axle 3	11000lb
Exit	1/3

Fig 3.04

#### b. Zero Inclinometers

**Note:** This step **MUST** be completed for mechanical springs with Axle transducers attached. This step is **NOT** required for Air only systems.

Select CALIBRATE	
Zero Inclinometers	
Zero	
Axle Spans	
Exit	1/3

Fig 3.05 Menu > Setup > Calibrate > Zero Inclinometers

Yes CONFIRM ZERO INCL.	
Are You Sure ? Yes/No	
No	1/1

Fig 3.06 Select Yes to confirm.

Calibration Data - Tare				
Axle	Measured Gross Weights (lbs)	Measured Gross Weights (lbs)	Sensor Signal	J/Box Angle
1				
2				
3				
4				
Total				

Fig 3.11

Yes CONFIRM ZERO INCL.	
Zero OK	
No	1/1

Fig 3.07 Message shown for process complete.

#### c. Zero

Menu > Setup > Calibrate > Zero

Select CALIBRATE	
Zero Inclinometers	
Zero	
Axle Spans	
Exit	2/3

Fig 3.08

Yes CONFIRM ZERO	
Are You Sure ? Yes/No	
No	1/1

Fig 3.09 Select Yes to confirm.

Yes CONFIRM ZERO	
Zero OK	
No	1/1

Fig 3.10 Message shown for process complete.

- d. Press exit 3 times to return back to the main user screen. This ensures the settings are all saved correctly.
- e. Record diagnostics for vehicle Tare on the relevant section of the *Installation and Calibration Record* as shown in figure 3.11.



3. Load vehicle as close to GVWR as possible, ideally on all axles. +/- 10% of GVWR will give the best results.
4. It is essential to check the weight of all axles. The front axle is especially important, it must increase in weight after loading. Some truck types can have little or no change in front axle weight when they are loaded. If that is the case you will need to add weight in the cab, enough to give an increase in weight of at least 2000 lbs.
5. With a full payload weigh the vehicle using either of the previously outlined methods. Calculate the individual axle weights in each case.

### 6. Calculate Axle Spans

- a. The axle span figures you need to enter into the meter are the axle net weights. They are calculated as follows:
- b. Subtract each axle tare weight from the weight from the axle gross figure measured by weigh pads or weighbridge for each axle.  
For example, axle 1 tare weight = 6000 lbs, axle 1 gross weight from the weigh pads or weighbridge = 14000 lbs. So  $14000 - 6000 = 8000$  lbs. The 8000 lbs is the figure you would enter into the meter for axle 1 net span. Record the figures on the relevant section of the *Installation and Calibration Record* as shown in Fig. 3.12.

Calibration Data - Span								
Axle	Measured Gross Weights (lbs)	Measured Gross Weights (lbs)	Indicated Gross Weights (lbs)	Sensor Signal		J/Box Angle	PI Value	PI%
1								
2								
3								
4								
Total								

Fig 3.12

7. With the loaded vehicle positioned on flat, level ground, on the meter select:
  - a. Menu > Setup > Calibrate > **Axle Spans**

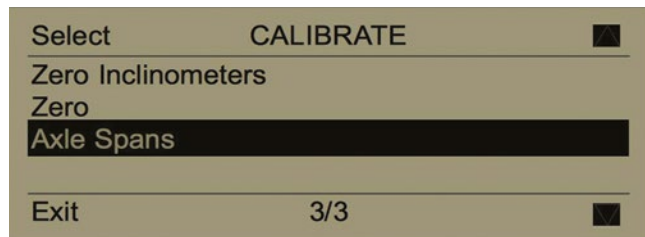

Fig 3.13

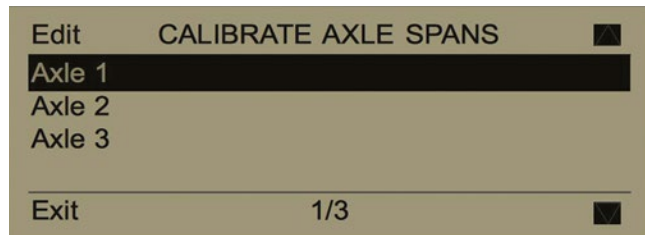

Fig 3.14 Select the first axle.



Fig 3.15 Press Select to edit the Axle Span as required.



Fig 3.16 Enter the calculated span weights. Press Exit once when the weight has been set.

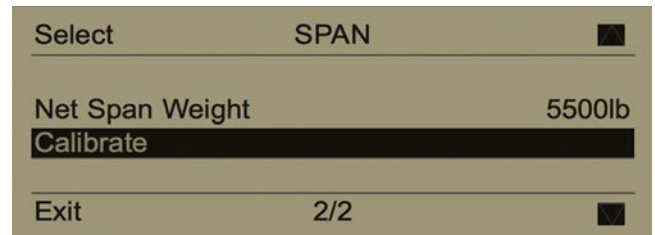

Fig 3.17 Select Calibrate.

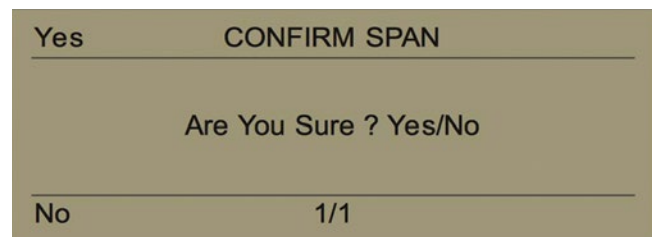
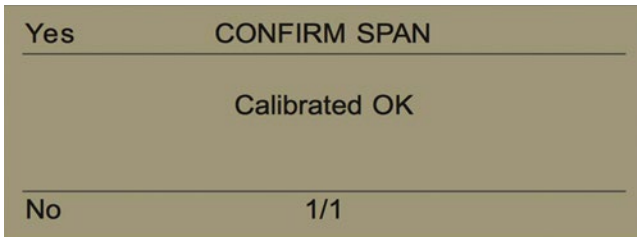

Fig 3.18 Select Yes to Confirm.





**Fig 3.19** Message shown for process complete.

Repeat for each axle.

- a. Press exit 3 times to return back to the main user screen. This ensures the settings are all saved correctly.
- b. Record diagnostics for vehicle Span on the *Installation and Calibration Record* record below.

8. Where required, enable any additional features such as Tag Axle Manager.
9. Complete loaded checks for slope compensation and zero return as detailed on the TruckWeigh™ Calibration & Zero Return Checks document.

Calibration Data - Span								
Axle	Measured Gross Weights (lbs)	Measured Gross Weights (lbs)	Indicated Gross Weights (lbs)	Sensor Signal		J/Box Angle	PI Value	PI%
1								
2								
3								
4								
Total								

**Fig 3.20**



# Appendices

### Junction Box Configuration Diagrams

The diagrams below show a selection of common applications in order to illustrate junction box mode settings for different axle configurations. Numerous other configurations are possible on condition that the limitations of the system are not exceeded, i.e. 8 sensors and/or 4 junction boxes.

#### 4x2 Rigid Chassis

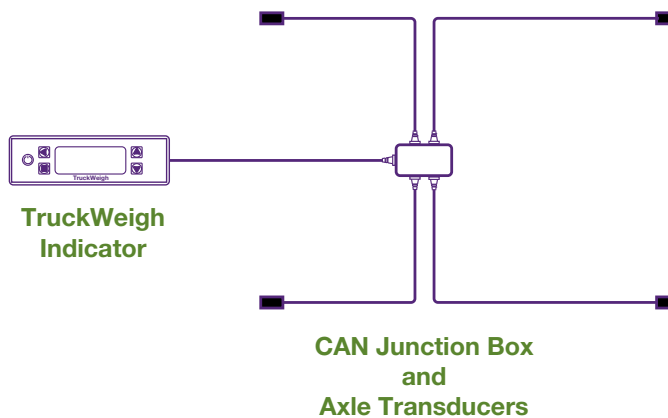
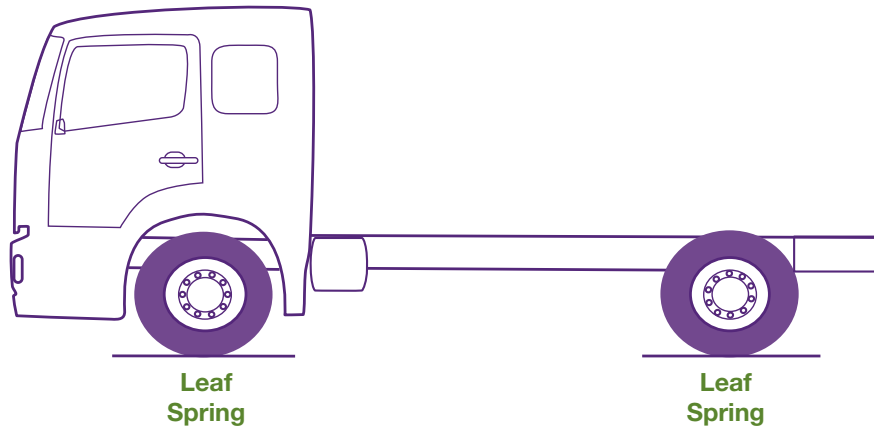

In the example above, the junction box can be left with its default factory setting as the TruckWeigh™ axle transducers will be numbered 1 – 4 using all the available sockets on the junction box.

## 6x4 Rigid Chassis

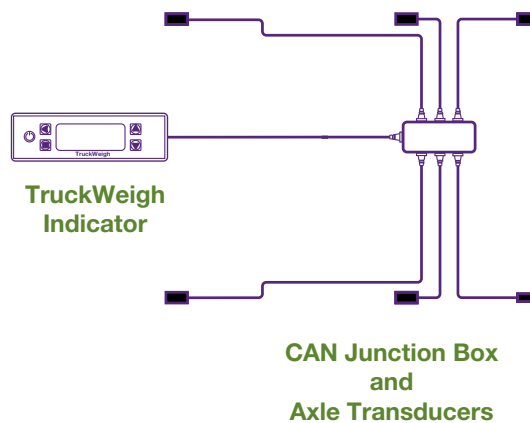
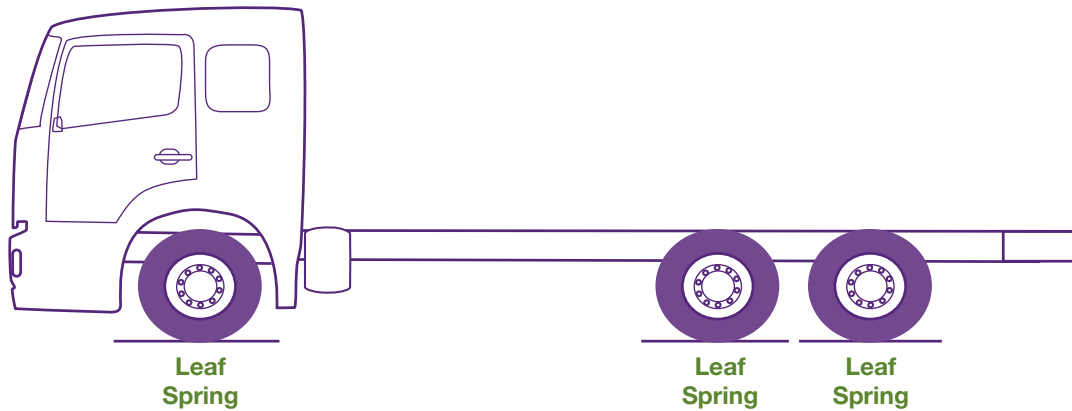

In the example above, the junction box can be left with its default factory setting as the TruckWeigh™ axle transducers will be numbered 1 – 6 using all the available sockets on the junction box.

Axes 2 and 3 are likely to be a tandem configuration. If this is the case the Bogie Mode setting should be configured accordingly – 1,2,[3,4,5,6],7,8

### 8x4 Rigid Chassis

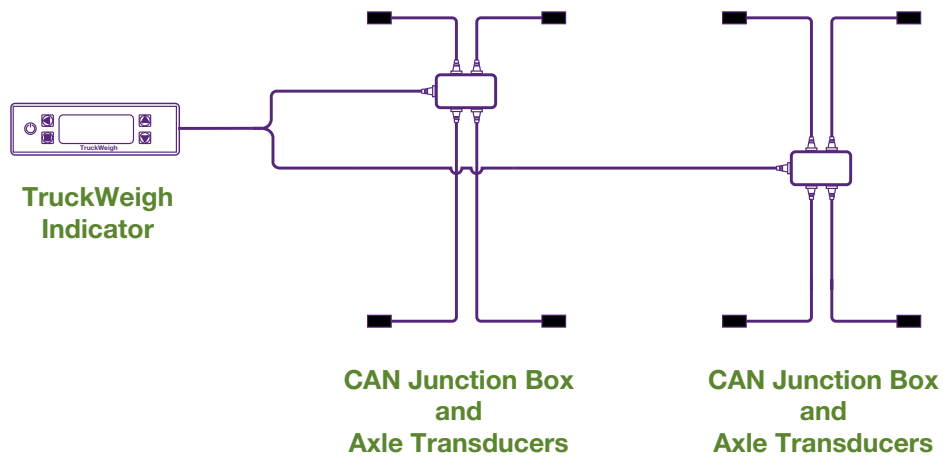
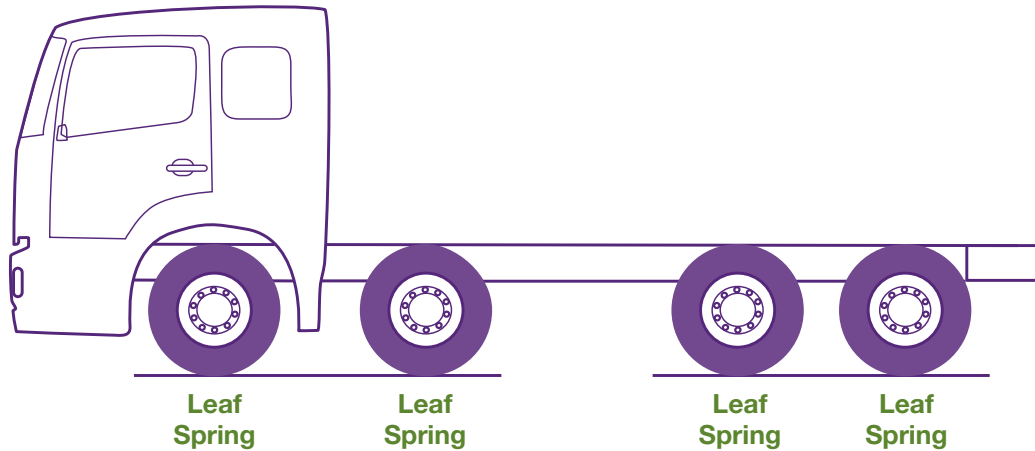

In the example above, the front junction box can be left with its default factory setting as the TruckWeigh™ axle transducers will be numbered 1 – 4 using all the available sockets on the front junction box.

The rear junction box will be using sensors numbered 5 – 8 which will mean it will need to be re-configured to mode 5. As with the front junction box all available sockets are used.

Axles 3 and 4 are likely to be a tandem configuration. If this is the case the Bogie Mode setting should be configured accordingly – 1,2,3,4,[5,6,7,8]

### 4x2 Rigid Chassis

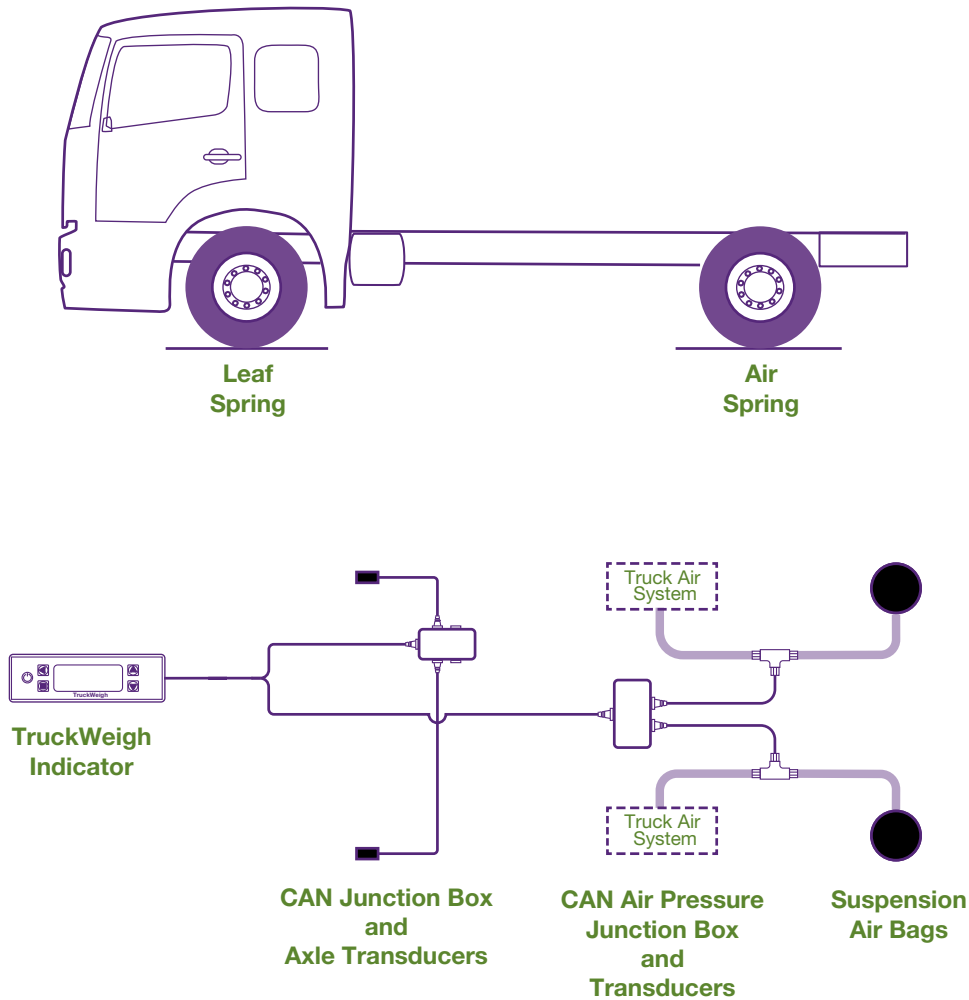

In the example above the front TruckWeigh™ axle transducers will be acting as transducers 1 and 2 and only occupying 2 of the 4 available sockets of the junction box. It will need to be re-configured to mode 1.

The rear air transducer interface box will be acting as transducers 3 and 4 (even if there is only 1 air transducer). It will need to be re-configured to mode 2.



### 4x2 Tractor/Trailer

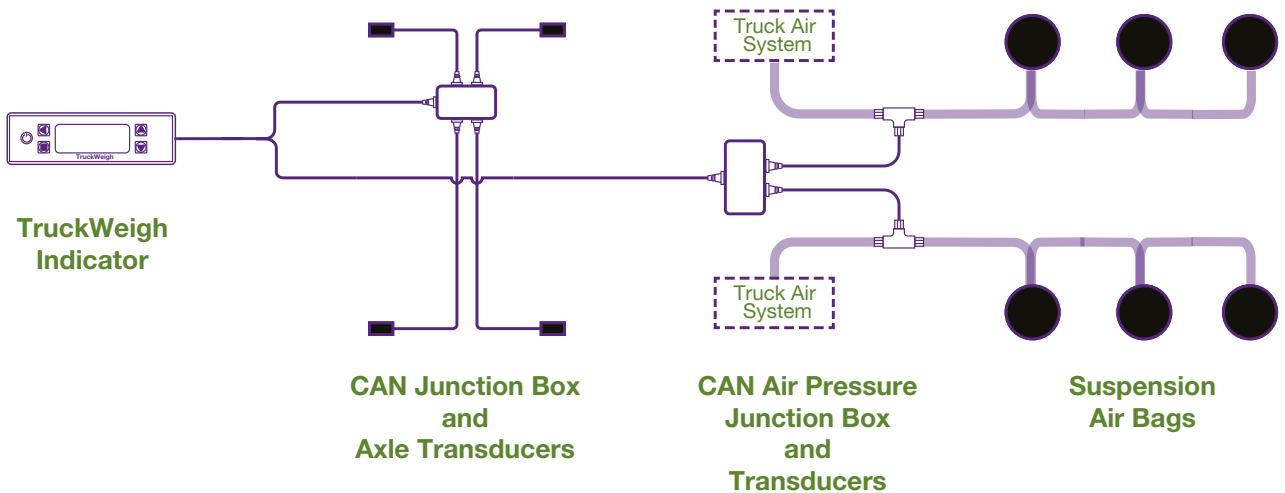
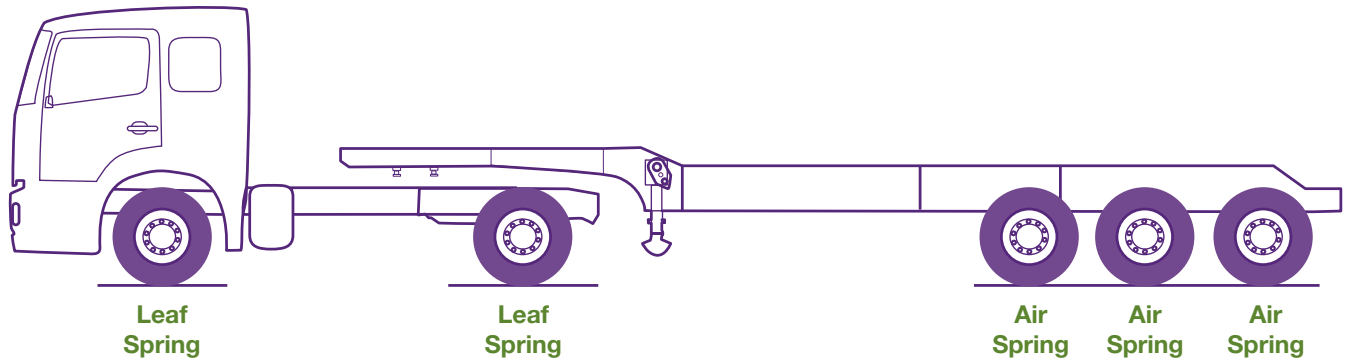

In the example above, the front junction box can be left with its default factory setting as the TruckWeigh™ axle transducers will be numbered 1 – 4 using all the available sockets on the front junction box.

The rear air transducer interface box will be acting as transducers 5 and 6 (even if there is only 1 air transducer). It will need to be re-configured to mode 3.

### 6x4 Tractor/Trailer

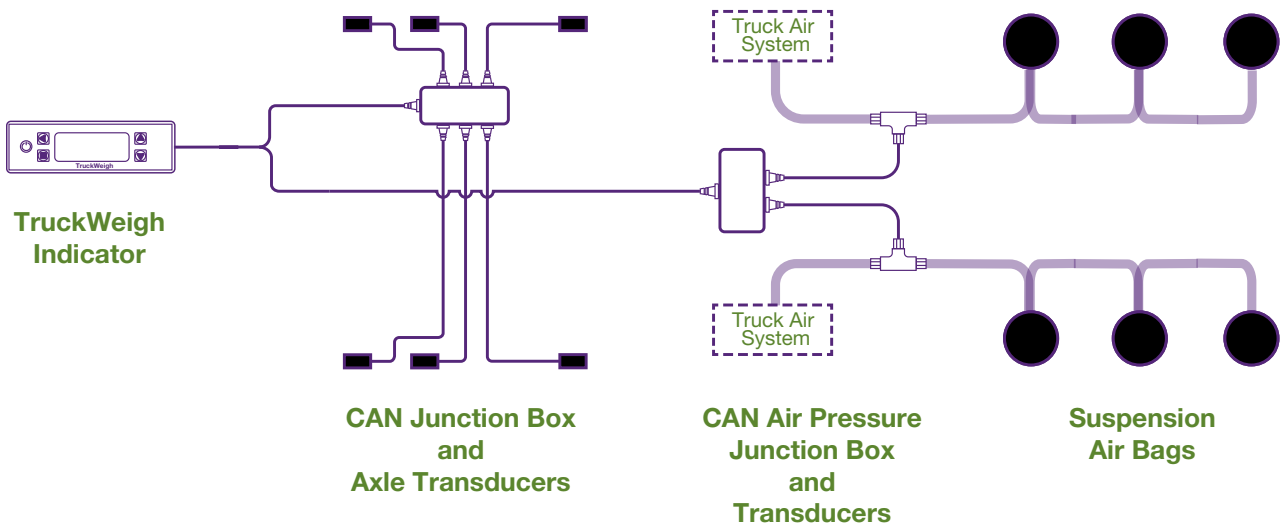
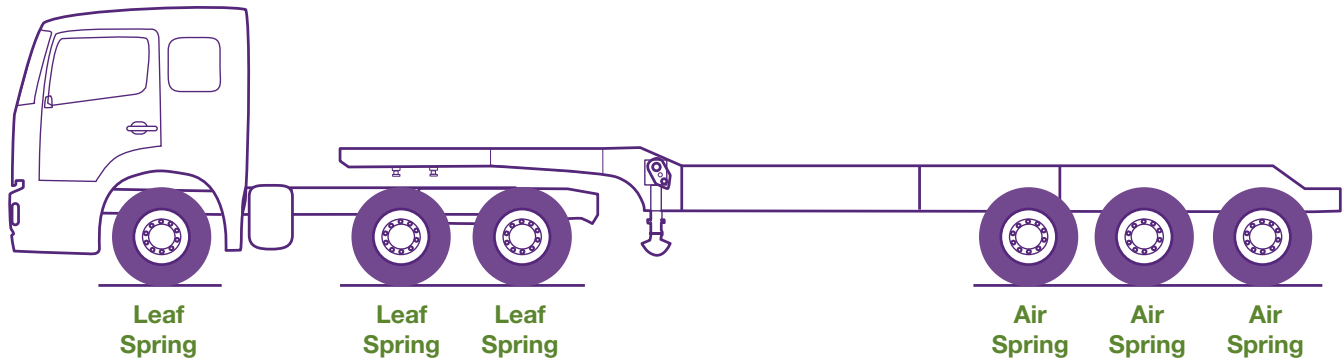

In the example above, the front junction box can be left with its default factory setting as the TruckWeigh™ axle transducers will be numbered 1 – 6 using all the available sockets on the front junction box.

The rear air transducer interface box will be acting as transducers 7 and 8 (even if there is only 1 air transducer). It will need to be re-configured to mode 4.

Axes 2 and 3 are likely to be a tandem configuration. If this is the case the Bogie Mode setting should be configured accordingly – 1,2,[3,4,5,6],7,8

### 4x2 Tractor/Trailer

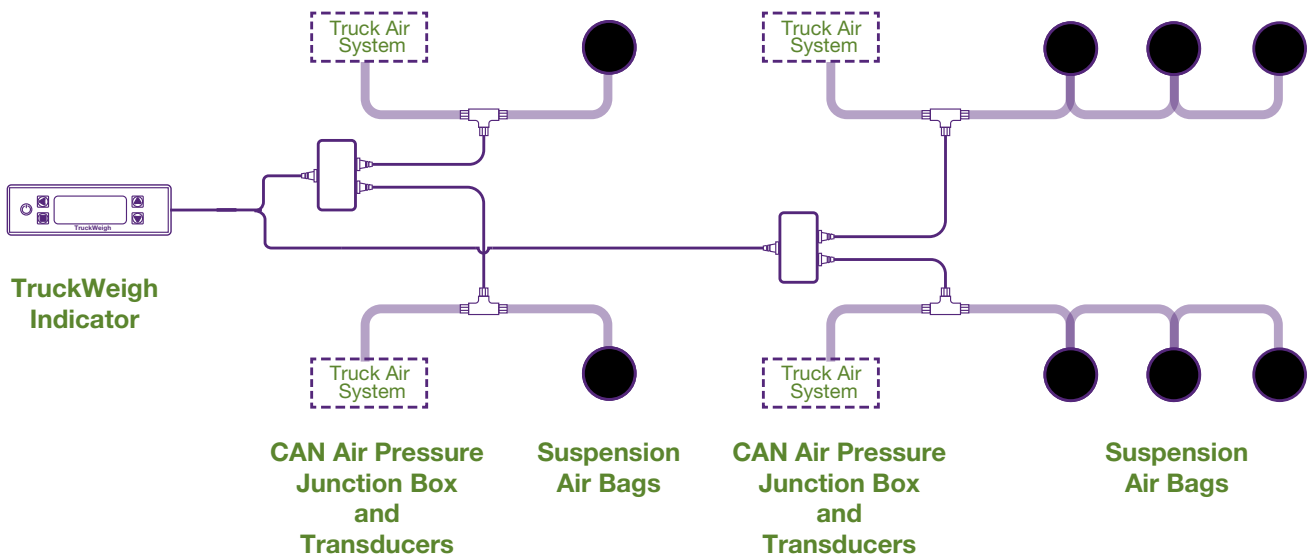
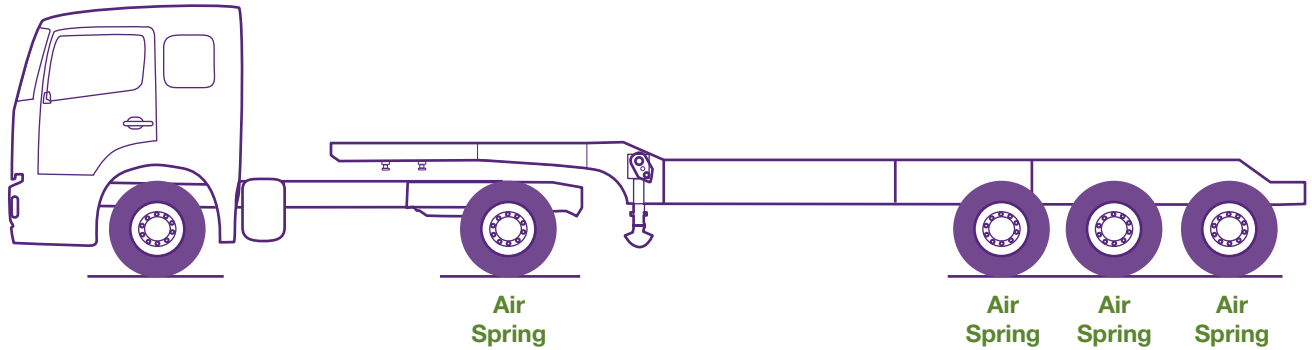

In the example above the front air transducer interface box will be acting as transducers 1 and 2 (even if there is only 1 air transducer). The front one can be left with its factory settings as it will default to mode 1

The rear air transducer interface box will be acting as transducers 3 and 4 (even if there is only 1 air transducer). It will need to be re-configured to mode 2.

### Summary of Settings/Parameters

The default values quoted assume the Weight Units setting has not been changed from its default configuration of “lbs (US)”.

					Default Value
<b>Display</b>	<b>Contrast</b>			Adjust the display contrast	3
	<b>Power on screen</b>			Choose which weight screen appears at power up	Axles
	<b>Key Bleep</b>			Enables/disables key beep	Off

<b>Setup</b>	<b>Alarms</b>	Mode		Auto mode re-arms the alarms when the truck is emptied	Manual
		Net		Alarm set point for the net alarm	80000 lbs
		Gross		Alarm set point for the gross alarm	80000 lbs
		Body up		Not used with TruckWeigh™ – for tippers with load cells	Off
		Stability		Not used with TruckWeigh™ – for tippers with load cells	Off
		Axle 1		Alarm set point for the axle 1 gross alarm	25000 lbs
		Axle 2		Alarm set point for the axle 2 gross alarm	25000 lbs
		Axle 3		Alarm set point for the axle 3 gross alarm	25000 lbs
		Axle 4		Alarm set point for the axle 4 gross alarm	25000 lbs
		Alarm filter		Filter to stop false alarm activation. Weights must be above the set point for this period before they trigger	7 seconds

	<b>Calibrate</b>	Zero inclinometers		Zeros off the sensors located in the junction box	
		Zero		Zeros the TruckWeigh™ axle transducers	
		Axle Spans	Axle 1	Sets the Span (full) point for axle 1	12000 lbs
			Axle 2	Sets the Span (full) point for axle 2	12000 lbs
			Axle 3	Sets the Span (full) point for axle 3	12000 lbs
			Axle 4	Sets the Span (full) point for axle 4	12000 lbs

					Default Value
	Vehicle config	Load cells		CAN – this cannot be changed	
		Weigh mode		Must be set to Multi axle. Standard, twin and draw bar are not valid for TruckWeigh™	Multi axle
		JBox config		This only appears when no J.Boxes are connected. Used to configure junction boxes identity	
		Number of axles		Configures the number of axles or axle groups	2
		Bogie position		Configures which axles have tandem (bogie) suspension	None
		Slope compensation	Axle 1	Configure the orientation of the TruckWeigh™ Axle Transducer with regard to the axle – axle 1	None
			Axle 2	Configure the orientation of the TruckWeigh™ Axle Transducer with regard to the axle – axle 2	None
			Axle 3	Configure the orientation of the TruckWeigh™ Axle Transducer with regard to the axle – axle 3	None
			Axle 4	Configure the orientation of the TruckWeigh™ Axle Transducer with regard to the axle – axle 4	None
		Tag axle group config	Tag axle group manager	On/off – this enables the tag axle function	Off
			Tag axle group position	Describes which axle group number the tag axle is in	3
			Signal axle down	Defines if the input signal is axle down = 0 volts (default) or if axle down = +12V	Low
			Axle deployment delay	This delay on acting upon seeing the axle down signal is to avoid false triggering due to transient spikes	50 seconds
			Tag axle rated wgt.	This is the rated weight of the tag axle. It will be on a rating plate in the truck's cab or for trailer on a chassis mounted plate.	0 lbs
			Total group weight	This is the rated weight of all the axles in the group in which the tag axle resides added together	0 lbs
		Axle tares	Axle 1	This is the empty axle weight of axle 1	12000 lbs
			Axle 2	This is the empty axle weight of axle 2	12000 lbs
			Axle 3	This is the empty axle weight of axle 3	12000 lbs
			Axle 4	This is the empty axle weight of axle 4	12000 lbs

					Default Value
		Cell PI values	Cell 1	This value is a calibration factor and should not be changed unless instructed to do so by a VPG engineer	16384 Note 1
			Cell 2	This value is a calibration factor and should not be changed unless instructed to do so by a VPG engineer	16384 Note 1
			Cell 3	This value is a calibration factor and should not be changed unless instructed to do so by a VPG engineer	16384 Note 1
			Cell 4	This value is a calibration factor and should not be changed unless instructed to do so by a VPG engineer	16384 Note 1
			Cell 5	This value is a calibration factor and should not be changed unless instructed to do so by a VPG engineer	16384 Note 1
			Cell 6	This value is a calibration factor and should not be changed unless instructed to do so by a VPG engineer	16384 Note 1
			Cell 7	This value is a calibration factor and should not be changed unless instructed to do so by a VPG engineer	16384 Note 1
			Cell 8	This value is a calibration factor and should not be changed unless instructed to do so by a VPG engineer	16384 Note 1

	<b>Settings</b>	Count by		This is the increments of weight the meter displays in.	100 lbs
		Filter		This is filtering that the sensors apply to the weight. Low changes faster but may be less stable and high is very stable but slower to change.	Medium
		Zero limit		This is the maximum net weight at which the tare function can be used. At net weight values above this setting the tare function will not operate.	2000 lbs
		Front panel tare		Tare is only visible to the user when “Display net” is enabled. tare can be used to zero the net weight on the screen.	On
		Display net		Net weight will be added to the user viewable screens by enabling this option	Off
		Load deliver		Load deliver is intended for load cell systems and is not relevant for TruckWeigh™ systems	Off
		Weight units		Weight units (kgs or lbs)	lbs



# SI Onboard TruckWeigh™ Manual

## Appendix B

					Default Value
	Outputs	Serial output - Printer	Baud rate	The data speed for the printer. It can be set to 1200, 2400, 9600, 19200, 57600 bits per second	9600
			Handshake	This is a signal that tells the meter to stop sending data until it has space in its buffer for more	Off
			Print header	The header is user configurable, this option turns it on or off	On
			Change print header	Edit the print header by scrolling through the words, changing the letters using the up and down buttons	
		Serial output - Scoreboard	Baud rate	The scoreboard output is a continuous stream of weight data. The data speed for the printer. It can be set to 1200, 2400, 9600, 19200, 57600 bits per second.	9600 Note 2
			Handshake	This is a signal that tells the meter to stop sending data until it has space in its buffer for more	
			Frequency	The time between data packet sets. This can be set to 0.5s, 1s, 2s,5s,10s	5 seconds
			Acknowledge required	This is where the device receiving the data acknowledges each bit of data before the meter sends the next one. It allows for data to be re-sent.	No
			Transmit retries	This is the number of times the data above is re-sent. It can be set to 1,2,3,4,5 or 6 times.	2
		Barrier control	Barrier	This feature is intended for load cell systems. It is used to request the barrier of a garbage truck moves forward when the rear axle weight(s) are close to maximum.	Off
		Barrier control	Barrier	This feature is intended for load cell systems. It is used to request the barrier of a garbage truck moves forward when the rear axle weight(s) are close to maximum.	Off
			Maximum incline	The operation of the barrier control feature is inhibited if the trucks pitch angle exceeds this	3.0
			Front axle(s) under load	If this feature is enabled and the front axle(s) weight(s) are less than 20% of trucks current GVW it will request the barrier to move forward	Off
			Axle 1 overload	Axle 1 overload is not currently used for anything	20900 lbs
			Axle 2 overload	If the truck has 2 or 3 axles and this figure is exceeded for longer than the filter time on level ground the move barrier forward signal is asserted	20900 lbs
			Axle 3 overload	If the truck has 3 or 4 axles and this figure is exceeded for longer than the filter time on level ground the move barrier forward signal is asserted	20900 lbs
			Axle 4 overload	If the truck has 4 axles and this figure is exceeded for longer than the filter time on level ground the move barrier forward signal is asserted	20900 lbs
			Filter weight	The weights from the axles triggering the barrier control need to be stable within this figure for the time below before the move barrier forward signal is asserted	200 lbs
			Filter time	See above	4 seconds

					Default Value
		CAN output		This is a data output for some VPM supplied add on options such as 511 hand held remote display	No
		Remote channel		You can choose the radio channel for a 511 hand held remote display, from channel A to O.	A
		Aux output 1		This output can operate giving +12V out of the expansion port on the rear panel of the meter when there is an alarm condition.	Off
		Aux output 2		This output can operate giving +12V out of the expansion port on the rear panel of the meter to request a garbage truck requests its barrier to move forward.	Off

	<b>Set time/date</b>			Set the time and date and enable daylight saving.	
--	----------------------	--	--	---	--

	<b>PIN access</b>	Set manager PIN		The manager PIN secures the setup menus from unauthorized tampering. The PIN can be set to whatever the customer wants	7711
		Set user PIN		The user PIN can only be enabled in addition to the manager PIN. It secures the alarm setting menus from unauthorized tampering. The PIN can be set to whatever the customer wants	0000
		PIN control		You can select from PIN – Off, PIN Manager and PIN User/Manager	Manager

	<b>Reset</b>	Re-learn		This option makes the meter “forget” extra devices it has previously had connected that are no longer connected.	
		Reset defaults		This re-loads the meters factory default values for all the items that can be set/configured.	

	<b>Diagnostics</b>	System		Shows battery and transducer excitation voltages and the firmware version	
		JBox config		Shows what the junction boxes are and what transducer numbers they are configured to be able to address	
		JBox software version		Shows the firmware versions in the attached junction boxes	
		External inputs		Shows the status of the external switch including axle down signal on input 1	
		Adjusted net		There are the net weights each sensor is actually measuring	
		Raw net		This figure is calculated from defined parameters and may be of use to a SI Onboard engineer	
		Signal		<p>Axle Transducers - represents the sensor angle and will have 2 decimal places (Horizontal = 90.00°)</p> <p>Air Transducers – represents the actual voltage from the air pressure transducer and will have 1 decimal place. Typically from 0.5V to 4.5V.</p> <p>These can be used to assist in diagnosing problems.</p>	

				Default Value
		PI value	This is an axle by axle calibration value that is set when each axle is calibrated	
		PI percent	This is another representation of the above item	
		Serial number	The transducer serial number. This is not currently used	
		Software ver	Transducer firmware version numbers are shown here	
		JBox inclinometers	This is for internal diagnostic use, showing junction box angles and an asterisk showing the angle currently being used	

**Note 1.** This default is stored in the Transducers, not the meter so defaulting the meter will not affect these figures.

**Note 2.** If you wish to decode the serial data from the scoreboard output you will need to sign an MNDAs (mutual non-disclosure agreement) with SI Onboard.

## Parts list

Item Number	Description
1400005	DUST COVER FOR TW J-BOX
1401155C	1155 MOUNT U-BRACKET
1401155D	1155 DIN MOUNT BRACKET
2500502	LABEL, SIGN, PM
2800514	CABLE TIE PACK
4300054	FUSE HOLDER, BLADE 220
4300055	FUSE BLADE, 3A
6000016	WIRE WRAP
6000102	ADHESIVE TAPE
6000103	TW SURFACE CLEAN SACHET
7100181-01	MOUNT KIT AIR TW
7100225	ADAPTER BLOCK FOR TW
8100024	CABLE, IND-JBOX 10 M
8100026	CABLE, CAN-BUS L/C 5MTR
8100027	CABLE, CAN-BUS L/C 10MTR
8100200	SIGNAL SPLITTER PM 1155
8100204	SUZI CABLE TRK
8100206	POWER CABLE PM1155
8100211	SUZI CABLE TRL, 15M
8100305	J-BOX, CANBUS TW 4 WAY
8100310	J-BOX, CANBUS TW 6 WAY
8100320	SINGLE CAN AIR TRANSDUCER
8100325	DUAL CAN AIR TRANSDUCER
8302210	TRANSDUCER TRUCKWEIGH
8501155-TW	METER TW 12V ONLY LB VER
8500655	PRINTER SPRINT 24 VDC
9500511	HAND HELD REMOTE 1155







## **SI Onboard**

**Post Office Box 1484 • Cumberland • MD 21502**

**Ph: +1-301-722-6000 • Fax: +1-301-722-7346**

**E-Mail: [obw.usa@vishaypg.com](mailto:obw.usa@vishaypg.com)**

**[www.obwvpg.com](http://www.obwvpg.com)**

---

For technical questions, contact:  
[obw.usa@vishaypg.com](mailto:obw.usa@vishaypg.com)