

## The Effects of Short-Time Overload on Resistive Elements in Precision Resistors

### Introduction

When designing any type of analog circuit, all possible causes of circuit instability or failure need to be taken into consideration, as do the consequences of these effects. Such considerations are particularly important when the long-term reliability, stability, and precision of the circuit are vital to the application.

One cause of failure in many applications is temporary exposure to unexpectedly high current spikes, or short-term overloads (STO). A component that is subjected to an STO will be required to dissipate more power than usual, causing extreme temperature rise that can lead to extensive component damage, and even catastrophic failure. However, designs that integrate overload protection can help prevent serious damage or component failure. Also, components can be pre-conditioned to eliminate or minimize STO damage by intentional pre-exposure to controlled STOs in an STO test performed by the manufacturer.

The STO test serves two purposes. In manufacturing, it is performed to burn out any residual conducting material that may bridge across random points along the resistance element. Such bridges would normally be relatively high resistance and burn out during the STO application. This assures a stable resistance value during actual use of the resistor. The second STO is normally performed on the completed ready-to-use resistor and is monitored to determine the amount of resistance shift experienced through the test. There is usually a specified limit on the amount of deviation allowed through the test. Since the resistor's change through load-life is a function of power, temperature, and time, the STO test stands as a figure of merit generally predictive of the long-term performance and reliability of the resistor.

### Bulk Metal Foil vs. Thin Film Resistors

The Bulk Metal<sup>®</sup> Foil (BMF) technology inherently has superior overload and pulse handling capabilities compared to other resistor technologies, such as thin film. It is characteristic of Foil resistors that they can withstand

prolonged periods of extreme overload conditions, without failure and without sustaining any serious internal or external damage.

The Vishay Foil Resistors (VFR) resistive element consists of a relatively thick, flat layer of conductive metal alloy, bonded to an inert alumina substrate, and photo etched into a matrix of resistance paths. This facilitates trimming to very tight tolerances. The resistor's design achieves almost zero reactance, allowing rapid rise times and excellent high-frequency performance.

Many of the advantages of the Foil resistors over thin film resistors are derived from the thickness of the resistive element, which is a dense monolithic alloy typically 100 times greater than that of thin film. This thickness provides a high heat capacity, which results in the low temperature rise of the resistive element under a short pulse. Thin film resistors, however, lack the pure mass, and therefore the heat capacity, to handle the heat generated in a short pulse, and will typically experience large resistance changes—often burning up in catastrophic failure.

Even under harsh environmental conditions, a Bulk Metal Foil resistor rated at a 0.01% purchased tolerance can retain most of this accuracy throughout its life, with only small predictable changes. Other precision resistors suffer greater drift with less predictability, and they may drift from their specifications by as much as several orders of magnitude.

VFR's Bulk Metal<sup>®</sup> Foil resistors are made to six-digit accuracy, exhibit one-tenth the thermal EMF of other resistor technologies, have better temperature stability and greater load life stability as well as enhanced reliability.

Though normally housed in moisture-resistant molded packages, the VFR line of foil resistors also includes surface-mount and hermetic packages for ultra stability.

### Short-Time Overload Test

VFR has developed a test that demonstrates the limited effect of STO on foil resistors when compared to competing technologies.

### The Effects of Short-Time Overload on Resistive Elements in Precision Resistors

The tested resistor (Rx) is connected to a precision digital multi-meter (DMM), which takes the initial resistance reading (see Figure 1). After the reading is taken, the resistor is switched over to a power supply that applies an overload voltage for five seconds. After a sufficient cool-down time, the subject resistor is then switched back to the DMM, and the resistance is read again. The deviation ( $\Delta R/R$ ) is displayed.

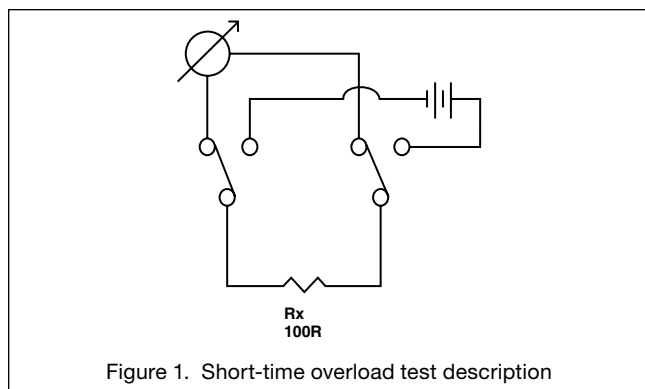

Figure 1. Short-time overload test description

The test measures the change in resistance of the subject resistor due to the applied overload. The screen displays the  $\Delta R/R$ , which is the variation of the resistance readings taken before and after the overload.

MIL-PRF-55342 defines the STO test as 2.5 times the rated continuous working voltage, but not exceeding twice the maximum voltage, applied for five seconds (see Figures 2 and 3). The resistors are then examined for evidence of arcing, burning, and charring.

This demonstration measures the  $\Delta R/R$  (measured in ppm) of a 100R resistor subjected to an overload of 7W for five seconds. This overload exceeds the power ratings of each device under test, specifically by a factor of nine for the VSMP2512 resistor, and a factor of seven for the thin film resistor.

Figure 2 shows the deviation of the foil resistors: 11 ppm (0.0011%) compared to Figure 3 which displays the deviation of the thin film resistors: 294,221 ppm (29.4%). As can be seen, the same test conditions were applied on both of the resistors.

```
POWER OVERLOAD TEST PARAMETERS .....
NOMINAL TEST VALUE ..... 100R
APPLIED WATTAGE ..... 7 W
ACTUAL APPLIED VOLTAGE ..... 26.5 VDC
TEST DURATION ..... 5 SEC.

PLACE TEST RESISTOR IN FIXTURE AND PRESS <T> TO TEST... <Q> TO QUIT PROGRAM

STAND BY ... TEST IN PROGRESS

** SYSTEM ZEROED **
READY FOR POWER SHOT

POWER SHOT ON !!! ** 26.5 VDC FOR 5 SECONDS **
** COOL DOWN CYCLE *** 5 SECONDS **

DELTA R (RC2-RC1).....11 PPM

ENTER <R> TO RESTART ..... <Q> TO QUIT PROGRAM .....
```

Figure 2. STO for Bulk Metal® Foil resistor

```
POWER OVERLOAD TEST PARAMETERS .....
NOMINAL TEST VALUE ..... 100R
APPLIED WATTAGE ..... 7 W
ACTUAL APPLIED VOLTAGE ..... 26.5 VDC
TEST DURATION ..... 5 SEC.

PLACE TEST RESISTOR IN FIXTURE AND PRESS <T> TO TEST... <Q> TO QUIT PROGRAM

STAND BY ... TEST IN PROGRESS

** SYSTEM ZEROED **
READY FOR POWER SHOT

POWER SHOT ON !!! ** 26.5 VDC FOR 5 SECONDS **
** COOL DOWN CYCLE *** 5 SECONDS **

DELTA R (RC2-RC1).....294221 PPM

ENTER <R> TO RESTART ..... <Q> TO QUIT PROGRAM .....
```

Figure 3. STO for thin film resistor

TECHNICAL NOTE

	Vishay Foil Resistors	Thin Film Resistor
Type	VSMP2512	Thin Film Chip 2512
Value	100Ω	100Ω
TCR	0.2 ppm/°C (MIL-RANGE)	25 ppm/°C (MIL-RANGE)
Rated Power	750 mW	1000 mW
$\Delta R$ Under Surge	<100 ppm	High (extremely high )

## The Effects of Short-Time Overload on Resistive Elements in Precision Resistors

The Bulk Metal<sup>®</sup> Foil resistors exhibit excellent stability and virtually no drift following the power spikes, demonstrating that the Bulk Metal<sup>®</sup> foil VSMP2512 chip resistor is capable of handling high power spikes well beyond common test limits.

The superior STOL capacity is also a function of its unique pattern design that prevents hot spots by means of a special trimming method.

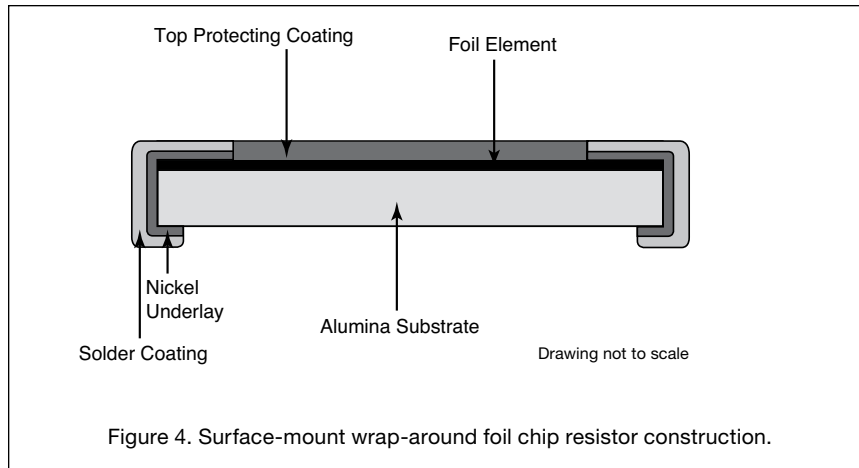

The following graph illustrates typical Foil resistor behavior after undergoing short-time overloads of 6.25 times rated power for five seconds:

