

## Ultra High-Precision Bulk Metal<sup>®</sup> Z-Foil Resistors with TCR as Low as $\pm 0.2$ ppm/ $^{\circ}$ C and Power Coefficient of $0 \pm 5$ ppm at Rated Power

### Prototype

There is more to resistor precision than meets the eye. The three basic types of resistors suitable for high-speed or surface-mount chip applications: Bulk Metal<sup>®</sup> Foil, Thin Film, and Thick Film are alike on the surface and may often have similar purchased specifications. However, beneath the surface, all three are different technologies and different constructions. Inherent design and processing will strongly influence electrical performances and all three behave differently after mounting. These differences will become apparent and vital as the external and internal temperature changes; also the effects of long-term stability, moisture and other environmental conditions take their additional toll with time. This should be taken into account particularly when the circuit requirements become stricter for Signal-to-Noise ratio (SNR) and pulse response. Thus, some so-called precision resistors turn out to be not quite as precise as you might expect after being used in the circuit. To produce a resistor with high precision and high stability characteristics, it is important to be able to control the influence of temperature and environmental conditions on the device's resistance. In precision circuits that require high stability it is essential to have a fundamentally low Temperature Coefficient of Resistance (TCR).

In precision resistor production, manufacturers document the resistor TCR in accordance with industry protocols that test the resistor after temperature stabilization in an oven with essentially zero power applied to the resistor. In actual use, the temperature of the resistor is comprised of both the ambient temperature (as in the oven) plus the temperature rise due to power dissipation (known as self-heating or Joule effect.) In very low TCR resistors, the change in resistance as a result of self-heating may be relatively high compared to the change due to ambient temperature. Therefore, Vishay Foil Resistors (VFR) defined a new concept known as Power Coefficient of Resistance (PCR) to give designers of high precision circuitry all the means of controlling — or at least, defining — the individual drivers of circuit precision. Even beyond the Foil resistor's industry-recognized standard of precision, VFR's Z-Foil technology reduces resistor sensitivity to both ambient temperature variations and changes in applied power to advanced levels of accuracy and precision.

Before selecting an appropriate precision resistor, take a hard look at how the three different types of precision resistors are made and test them to see how these will perform in service.

### Example of Power Coefficient Test on Surface-Mount Chip Resistors

In the test, we used three different surface-mount chip resistor technologies in the same size and same resistance value (1k). The TCR was measured in each of the resistors (MIL range:  $-55^{\circ}$ C to  $+125^{\circ}$ C,  $+25^{\circ}$ C Ref).

**The VSMP1206 (Foil) chip was randomly selected; and in contrast, we intentionally selected the thin film and thick film chips with screening to obtain the best TCR.**

During the PCR test, we applied power to the resistors in steps from 100 mW to 500 mW and measured the resistance change during the entire test run.

The test is completed in approximately 2 minutes, as opposed to long-term life tests that run for up to 10,000 hours. However, this short-term test is sufficient to indicate the stability of the resistor and serves as a reasonable predictor of long-term stability — a useful figure of merit that can be obtained in a very short time.

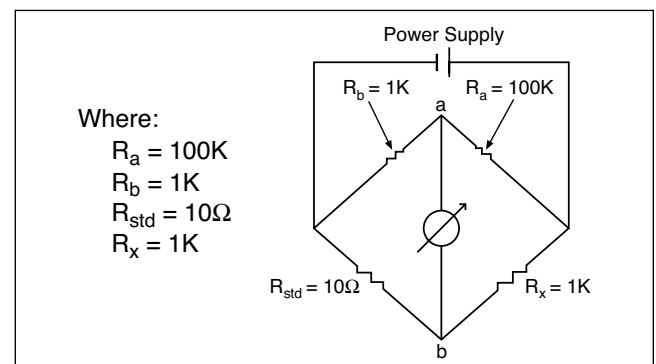

We used a basic Wheatstone bridge circuit. The resistance values of the arms of the bridge were selected to place a high power on the test resistor ( $R_x$ ), while ensuring a very low power on the three remaining legs. When the power is increased, any deflection in the null meter between points a and b is attributed to the self heating of  $R_x$ .

Formula:  $R_b \cdot R_x = R_{std} \cdot R_a$  or  $1k \cdot 1k = 10 \Omega \cdot 100k$

### Ultra High-Precision Bulk Metal<sup>®</sup> Z-Foil Resistors with TCR as Low as $\pm 0.2$ ppm/ $^{\circ}$ C and Power Coefficient of $0 \pm 5$ ppm at Rated Power

Resistor Technology	Maximum Measured TCR	Maximum PCR at 500 mW
Foil (Z-Foil technology) randomly selected	+1.29 ppm/ $^{\circ}$ C	$0 \pm 5$ ppm
Thin Film*	+4.18 ppm/ $^{\circ}$ C	>170 ppm
Thick Film*	+31.33 ppm/ $^{\circ}$ C	>1000 ppm

\*Chips with the lowest absolute TCR were selected for the thin film and thick film samples.

#### Behavior of Three Different Resistor Technologies Under Applied Power (Power Coefficient Test)

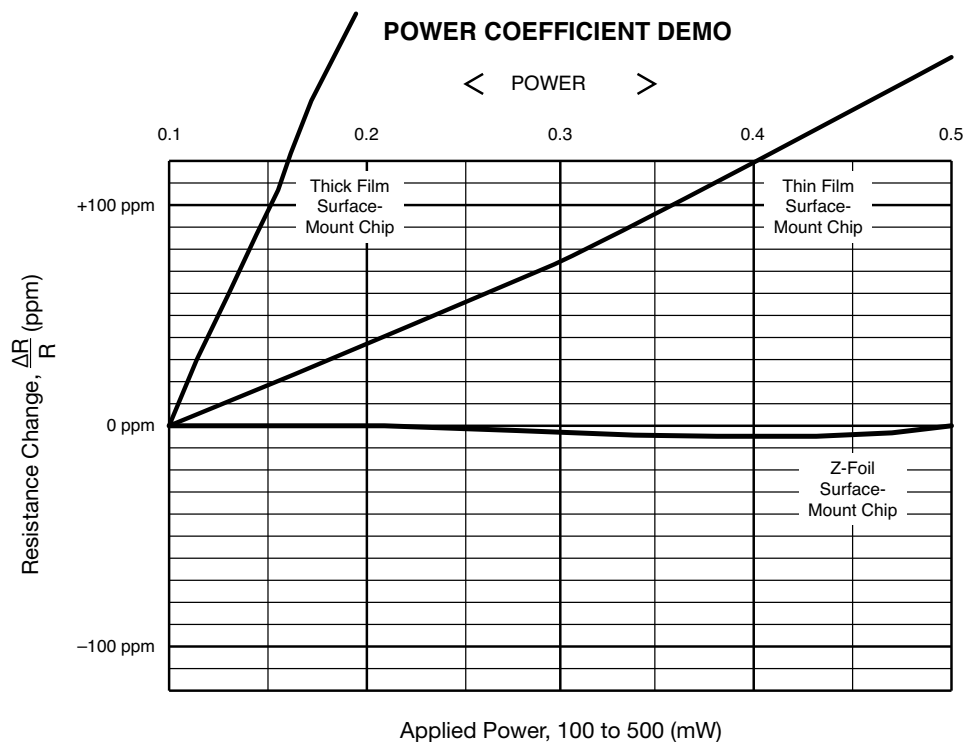

#### Conclusions

High precision Z-Foil resistors provide the best available stability during changes in resistor temperature induced by two effects:

- Change in ambient temperature and heat from surrounding components (TCR)
- Internal heating due to load changes (PCR)

It is necessary to take into account the differences in the resistor behavior for each of the above mentioned temperature factors.

Even a small difference in TCR such as 3 ppm/ $^{\circ}$ C (see table above) results in a very high shift of resistance due to applied power.