

Authors: Yuval Hernik

Tel: +972-54-3000191

E-mail: Yuval.Hernik@vishaypg.com

What Kind of Commercial-off-the-Shelf (COTS) Precision Resistor Should I Use for a 4–20 mA Current Loop?

The 4-20 mA circuit is widely used in many monitoring and control circuits. It is often used in many industrial applications where processes are remotely monitored and controlled from a central station upwards of 1000 feet from the processes themselves. But it is also used in applications where the monitors are very close to the process being monitored. This is accomplished with a closed loop circuit that includes a DC power supply to power the loop, a sensor/transducer/transmitter that inserts the sensor-related current into the loop, and a read-out or control device at the other end of the loop. Generally, analog sensors with just microvolt level outputs continuously detect changes in any significant stage in the process, e.g.: temperature in containment vessels, flow rate in pipes, positioning of control equipment, pressure in a boiler, etc. The analog sensor output is often amplified to a convenient working level, processed, converted to an output current and distributed over a long distance to a remote facility where a monitor or control circuit indicates a set of readable characters representative of the output of the sensor.

The low output voltage level of the analog sensor and the long distance to the control room together constitute significant system design challenges. To begin with, the processing of the microvolt level sensor output must be brought up to a suitable level for processing with minimal loss or distortion. This is generally accomplished by superimposing the low-level sensor output signal onto a higher-level carrier signal through a bridge network, with its output feeding directly into a differential amplifier to extract and amplify the lower signal while rejecting the common carrier signal completely. The differential amplifier requires a set of precision resistors for complete common mode rejection. The surviving amplified sensor output voltage is then converted to a current representative of the sensor output signal.

Then this current signal must be transmitted to a distant location with minimal distortion, suppression, interference, noise, or attenuation. Wireless transmission is subject to noise and interference so the transmission is accomplished via fixed wire connection to the monitoring station. The long transmission line and all the components along the circuit may change due to heat, cold, stress, and drift, but the sensor-related current injected into the loop must remain the same throughout the loop regardless of changes within the loop (Kirchoff's law.) The 4 mA minimum current provides a stable zero-signal base circulating current not influenced by any resistance changes in the circuit. The 4 mA is used as the zero-signal so that there can be a definitive differentiation between this zero-signal and an open circuit while the sensor-related current injected into the loop is added to the minimum 4 mA base current.

Finally, there must be an accurate and reliable means of pulling the actual sensor-related signal from the line, from the amount of current above the zero-base 4 mA current. The system's maximum signal is generally 20 mA because this amount of current conveniently converts to a 5 V level with the selection of a suitable sense resistor, with 4-20 mA producing the 1 V to 5 V commonly used for metering and control circuits.

A 250 Ω precision Bulk Metal[®] Foil resistor is often used as the sense resistor in the current loop. This is a critical resistor for system operation. Because the voltage across this resistor is fed directly to the meter, any error in this resistor would present a wrong voltage to the meter and the system would erroneously indicate that the sensor is reading a condition that it is not actually reading. The process control correction then made on this basis would then cause the system to operate at less than optimal conditions and reduce its process efficiency, which could result in increased operating costs, environmental pollution, hazardous spills, associated fines, and poor product quality.

Because the sensor output is often amplified from a microvolt level and converted to the current output of the transmitter, the transmitter output—while being representative of the sensor output—does not necessarily have a linear relationship to the sensor output. Therefore, a percentage error in the sense resistor may represent a much larger misrepresentation of the sensor output than that same percentage. So the stability of the sense resistor is a critical factor in the monitoring and control of the system.

Examples of common current loops circuits:

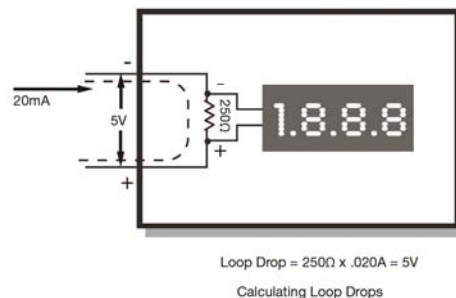
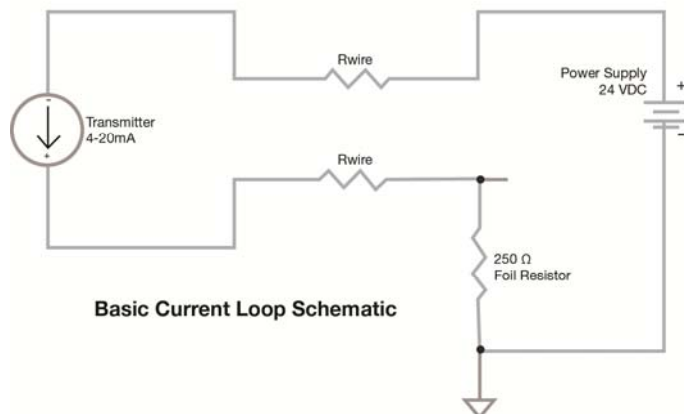
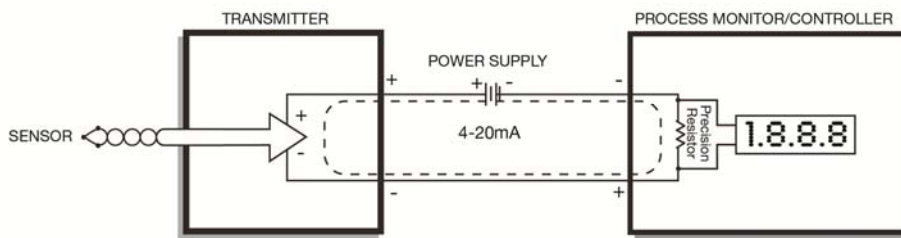

Critical Factors in the Stability of the Sense Resistor

Long-term stability

Some process controls are not very critical but many, many are—particularly when a process is operating near a tipping point where it could get out of control quickly if not well monitored. Entire production batches have been lost or suffered reduced reliability when critical parameters were not kept within narrow limits. One thing that can cause this to happen is changes in the precision sense resistor over time. Reference points in the control process thus become less and less reliable. Repeatability of the process from batch to batch begins to drift. The process is changing while the monitors appear to be holding it within specified limits because the sense resistor is producing a different output voltage than it was in previous runs for the same sensor output. So the process appears to be under control when, in reality, it is experiencing an undetected drift.

Long-term stability is thus one of the considerations that drive the selection of which resistor technology to use in the application. Wirewound resistors might be considered for leaded configurations, though they are much less often used in modern assembly practices. As for surface-mount chip resistors, the options are thin film versus foil. Thin film resistors, however, are more sensitive to ESD, have poor thermal stabilization, and have worse load life stability. But the typical permanent resistance drift of a Bulk Metal Foil resistor is less than 60 ppm (0.006%) after 10 years running at 0.1 W at 70°C.

Thermal EMF

In a resistor, the resistance is composed of a resistance element of one material and two terminations of a different material. When the junction of the element and the termination is heated in a closed circuit, there is a DC voltage generated in the circuit (see Seebeck and Peltier Effects). The polarity of the voltage is in one direction moving from material A to material B, but is the opposite polarity when moving from material B to material A. Hence, if both termination junctions of the resistor are at exactly the same temperature the voltages cancel each other out and there is no net thermal EMF voltage generated in the circuit due to thermal EMF error voltages in the resistor.

In fact, however, the terminals are very seldom at the same temperature because their temperatures are influenced by uneven power dissipation within the resistor, differential heating from other components on the board, and heat conducted along the board itself. Obviously, in a sense resistor that's supposed to accurately convert a current to a voltage, the presence of an extraneous thermal EMF voltage could constitute a significant error source in the system. That is why it's important that Bulk Metal Foil resistors have a thermal EMF voltage of less than 0.1 mV/°C difference across the element to termination junction.

ESD and Latent Defects

Handling and assembly practices at the equipment manufacturer generally include grounding of assemblers and other ESD protection procedures. However, resistors may already have latent ESD damage that cannot be observed because the damage is under the coating or encapsulation. Or, the hidden damage may occur at the end customer's facility, particularly when being installed at the end customer's plant. Latent damage occurs when an ESD event damages an element under its coating but doesn't totally open the element so that the damage could be detected and the resistor discarded. Resistors containing latent damage are subject to early life failure in application, thereby risking loss of entire processes in the monitoring and control applications. Thin film resistors are subject to significant resistance change with ESD exposures as low as 300 V up to 3,000 V, while Bulk Metal Foil resistors withstand ESD charges of at least 25,000 V.

Reliability

In addition to possible ESD damage, there are other reliability considerations. Since the 4-20 mA loop is a DC current, there is another, often overlooked reliability concern: moisture. All epoxy coatings and plastic encapsulants are hygroscopic; they absorb moisture from the air. Under the varying temperature, pressure, and humidity conditions of normal operations, moisture is drawn through the external coatings and elevates the humidity level of the inside of the resistor to a higher level than the unrestrained fluctuating conditions outside the resistor itself. If the resistor were to run at high power and generate a lot of heat, the moisture would be driven out of the resistor and there would be no humidity consequences. But the best conditions for long term load-life stability are the worst conditions for moisture damage in low DC power applications. When the moisture is drawn into the resistor it imports minute ions from the coating to the resistor element's surface where it adds to any residuals left during production. These materials form a mild etchant in the presence of the electric field established across the element by the DC voltage. This etchant then begins to remove resistance material from the resistance grid, transports it across the surface of the element and deposits it on another portion of the resistance grid. This process can open a thin film resistor in just a few hours of operation or effect a more gradual increase in resistance over a longer period of time, opening after months rather than hours.

The resistance grid of the Bulk Metal Foil resistor is hundreds of times thicker than an equivalent value thin film resistor so it would take hundreds of times more chemistry to do the same amount of damage as to the thin film resistor. In military-qualified chip resistors (Mil-PRF 55342) there is a moisture test but this test does not use any applied power during the moisture exposure so even mil-qualified thin film resistors are not tested for this condition.

Temperature Coefficient of Resistance (TCR)

TCR is more important in some applications than in others. Where the sense resistor is in an office control station environment the temperature is fairly well controlled over a narrow range but when the sense resistor is close to the processes the sense resistor may be exposed to a much higher range of temperatures.

Using a thin film resistor at ± 10 ppm/ $^{\circ}\text{C}$ would result in a 100 ppm (0.01%) error if the ambient changes by only 10°C . If the temperature of operation is not close to the midpoint of the temperature range used to quantify the TCR at ± 10 ppm/ $^{\circ}\text{C}$, it would result in a much larger error over higher temperature ranges. A Bulk Metal Foil resistor would only change 0.0002% to 0.002% over that same 10°C span, depending upon which model is used (0.2 ppm/ $^{\circ}\text{C}$ to 2 ppm/ $^{\circ}\text{C}$.) And for larger temperature spans, it would be even more important to use the Bulk Metal Foil resistor for its inherently low TCR.

Flower Of Sulfur (FOS) and Surface-Mount Foil Chip Resistors

ASTM B 809, also known as flower of sulfur (FOSO), is a test to determine the porosity of metallic coating using humid sulfur vapor. This vapor can penetrate conformal coatings and cause damage to the device when it reacts with lower layers of silver. Surface-mount Bulk Metal Foil chip resistors avoid this problem with a special coating that is proven to be reliable in extreme environments and even against sulfur. The flower of sulfur test is especially relevant to designers of circuits used in alternative energy and industrial applications, where environmental pollution is a constant concern. Analog circuitry in these applications almost always operates under severe environmental, thermal, and mechanical conditions, and must withstand frequent and extended service by professionals and novices alike. The picture is further complicated by tough regulatory restrictions and high consumer expectations. VFR received a steady stream of customer inquiries, which led to more focus on anti-sulfurated resistor research and development. As a result we have qualified our surface-mount foil chip resistors as "anti-sulfurated resistors." These are designed mainly for use in environments with high levels of contamination. Beyond alternative energy, applications include industrial control systems, sensors, RTDs, electric instrumentation, weather and communication base stations. These resistors are also suited for electronic appliances used in high concentrations of sulfur.

Harmonic Distortion

Harmonic distortion is an important consideration in the choice of precision resistors for sensitive applications. A significant signal voltage across the resistor may change the resistance value depending on the construction, material, and size. Under these conditions Bulk Metal Foil resistors behave more linearly than other resistor types.

In summary, prudent designers consider all of the possible problems that could affect the performance and reliability of their monitoring and control circuits and select the sense resistor that best protects the performance of their equipment, the security of their end customer's business, and their own company's reputation. To do this they must first thoroughly understand the differences among the resistor technologies available and select the best one for the application.

Further information about Vishay Foil Resistors products is available at:
www.vishayfoilresistors.com

Follow Vishay Foil Resistors at: <http://twitter.com/FoilResistor>

For more information about this product group, please contact us at: foil@vishaypg.com