

G4 PROGRAM DESCRIPTION

Program: G4MI_1.2.109.8



Special program for Crane Weighing

Content

Function	4
General	4
Operation	7
Calibration	9
Set-Up.....	12
Menu 'General'	12
Menu 'Calibration'	12
Menu 'Communication'	15
Menu 'Level supervision'	15
Menu 'Inputs'	16
Menu 'Analog outputs'	17
Menu 'Program options'	17
Program options.....	18
Communication	19
Command register	21
Channel X: Status.....	22
Life Cycle Measurement (Option 14)	23
Full load hours	27
File handling	28
Connections for service information.....	32
Mean value calculations (option 15)	33
Rope Weight Compensation (option 16).....	34
General.....	34
Required inputs	34
Set-Up and Calibration of rope weight	35
Operation with rope weight compensation activated.	36
Upgrading software	37

This description is valid for:

G4 Weighing Instrument with application program **1.2.109.8**

See also the following descriptions

G4 Weighing Instrument Program version 1.2.0.0

Technical Manual PM/DT/HE (www.vishaypg.com/doc?35160)

G4 Weighing Instrument Program version 1.2.0.0

Operating instructions, Quick installation PM/DT/HE (www.vishaypg.com/doc?35196)

or

G4 Weighing Instrument Program version 1.2.0.0

Technical Manual RM (www.vishaypg.com/doc?35131)

G4 Weighing Instrument Program version 1.2.0.0

Operating instructions, Quick installation RM (www.vishaypg.com/doc?35134)

If these descriptions in any case are contradictory, this description is valid.

Special Program options:

To get the functionality described below the following program options has to be activated.

Program Option 13: Crane weighing functions.

Program Option 14: Life cycle measurement.

Program Option 15: Mean value calculation.

Program Option 16: Rope weight compensation

See a detailed description of 'Program options' below.

Function

This special program has functions, special for crane weighing, overload supervising and life cycle measurement for SWP analysis. Statistical data over the use of the crane is gathered and can be written to file for further analysis.

For high accurate weighing applications, there is also an option (option15) with a mean value functionality that can be internally and externally turned on or off.

Where outrolled rope weight affects the weighing, a option (option 16) is added for rope weight compensation.

The program can be used in all versions of G4 weighing instrument (both with graphical display (PM/HE/DT) and with Viewpan service display (RM)).

General

Added functions in this program are

Crane weighing functions (option 13):

- Connect each load cell in the main hoist and auxiliary hoist's to a separate weighing channel in the G4, and supervise the load on each channel with one or more of the 32 available level functions.
- Configure a 'Main Hoist' by defining how many load cells (1 – 8) are used in the main hoist. The 'Main hoist' window displays the sum of these channels with gross and net weight, as well as indicators of the status for eight configured

level functions.

Level supervision can be configured for the sum of all channels in the 'Main hoist', as well as for the sum of each side of the 'Main hoist' and also for the difference between the sides of the 'Main hoist', using any of the 32 available level functions.

- The 'Total crane' window displays the sum of all configured channels (main hoist + all other channels) with gross and net weight, as well as indicators of the status for eight configured level functions.
Level supervision can be configured for the sum of all channels, using any of the 32 available level functions.
- Set a delay on any of the level functions between 0 - 10000 ms to allow for temporary dynamic overloads. Set also a 'Max load' on any of the level functions, where the delay is disabled and the level is acted on immediately.
- Level status and indicators now follow the status of a configured output for the level
- Allow for any channel to 'simulate' the weight from another channel (use for temporary disconnection of a channel, and still be operable).
- Communicate the four 'Main hoist' values (sum of all load cells in main hoist, left side, right side, and difference between left and right side) as well as the sum of all channels (main hoist + all other channels) via serial communication (modbus rtu, modbus tcp or fieldbus) or output them on any of the four possible analog outputs.
- If channel name is set, this name is displayed in the channel displays instead of only channel number (scale number). An arrow next to date and time shows if there are more channels to scroll to (upwards or downwards).

Life cycle measurement functions (option 14):

- Added functionality for gathering operational data over time, for SWP analysis. These data are displayed in a new menu called 'Service information'
- 'Full load hours' calculation is done on the sum for the 'Main hoist' and each channel (1 – 8) can be configured to do its own 'Full load hours' calculation.
- Statistical data is gathered and displayed in 41 windows under the menu 'Service information' (32 windows for the 32 level functions, 8 windows for the 8 separate channels, and one window for the 'Main hoist').
- All statistical data can be saved in a log file.
- All nine 'Full load hours' values can be read via serial communication (modbus rtu, modbus tcp, or fieldbus).

Mean value functionality (option 15):

- Function to get a rapid stable value (on all channels) even if load is swinging. This is only useful when weighing in crane, and requires that the change in load (due to swinging) is less than a configurable deviation from mean value.
- The function does not affect the level supervision functionality or the life cycle measurement functionality.

Rope Weight Compensation (option 16)

- Function to get the **Main hoist** weight compensated for the outrolled rope. In some applications the load cell(s) are located so that the outrolled rope affects the weighing (is normally added to the weight). To compensate for this and only show the lifted load, this option calculates the weight of the outrolled rope and subtracts this weight from the measured load so that the lifted load is shown. This is affecting the weight shown in the window for the main hoist. See separate chapter for a description of this function.

Operation

The G4 will start up showing the 'Main Hoist' window, where the sum of channels in the main hoist is displayed, with both gross and net value. Here is also displayed status for eight configured level functions, indicating the level number, and the status for the levels.

Main hoist window (for PM/HE/DT versions of G4)

Main hoist	2006-09-24 19:07			
Gross	102.8 t			
Net	Zero 000.0 t			
Levels	1: <input checked="" type="checkbox"/>	2: <input checked="" type="checkbox"/>	3: <input type="checkbox"/>	4: <input type="checkbox"/>
Levels	21: <input checked="" type="checkbox"/>	22: <input type="checkbox"/>	23: <input type="checkbox"/>	32: <input type="checkbox"/>
-----	-----	-----	Levels	Chan.1-8

For both weights, there are also indicators for 'Motion' and good 'Zero'.

Pressing the 'TARE' button in this window causes a tare command to all channels used for the main hoist. If all channels were able to perform a tare, the result of the command is indicated in the net value that should change to zero.

Pressing the 'ZERO' button in this window causes a zero command to all channels used for the main hoist. If all channels were able to zero (the gross weight) this is indicated in the gross value that should change to zero.

Note. The zero correction range is extended to -10% to 10% of capacity.

By pressing the soft key 'Levels' (F4) a window opens where all the configured levels are shown.

Separate channels window (for PM/HE/DT versions of G4)

By pressing the soft key 'Chan.1-8' (F5) a window opens where all the separate channels are shown in the same way as in a normal weight indicator. Here all channels that are used for the main hoist is shown, as well as other configured channels (e.g. auxiliary hoists etc.).

An arrow next to date and time shows if there are further channels to scroll to. The arrow points downwards, if there are channels 'below' the display window, and upwards if there are channels 'above' the display window, and both upwards and downwards if there are channel in both directions to scroll to.

Chan. 1-8		2006-09-24 19:07 ↓		
North side		052.8 t		
Gross				
South side		050.0 t		
Gross				
Aux 1		000.0 t		
Gross Zero				
Aux 2		004.9 t		
Gross				
M. hoist	Total w.	P.Tare	Levels	-----

Total weight window (for PM/HE/DT versions of G4)

In the opened window there is a soft key 'Main hoist' (F1) that return the display to the 'Main hoist' window. There is also a soft key 'Total w.' that opens a window similar to the 'Main hoist' window but instead displaying the sum of all channels configured for the crane (main hoist + all other channels).

Total crane		2006-09-24 19:07		
Gross		107.7 t		
Net		000.0 t		
Zero				
Levels	1: <input checked="" type="checkbox"/>	2: <input checked="" type="checkbox"/>	3: <input type="checkbox"/>	4: <input type="checkbox"/>
Levels	21: <input checked="" type="checkbox"/>	22: <input type="checkbox"/>	23: <input type="checkbox"/>	32: <input type="checkbox"/>
-----	-----	-----	Levels	Chan.1-8

For RM version of G4 the gross and net weight of the 'Main Hoist' can be displayed by selecting scale 9 (in the same way as for channels 1-8).

Calibration

The separate channels NOT used in the 'Main Hoist' should be calibrated as described in the standard manual for G4.

It is **important** that all channels used should be set up equally with regards to the common parameters (update rate, filter parameters), when synchronised weights are needed in order to correctly calculate 'Full load hours'.

Main Hoist calibration

The channels used for the 'Main Hoist' (1-X) should normally be set up equally with regards to the common parameters (unit, resolution, update rate, filter parameters, motion parameters...), when the 'Main Hoist' values (total, left, right and difference weights of main hoist) are calculated from the weights from the separate channels.

Each channel in the main hoist should then be calibrated using the '**Data sheet**' calibration method (recommended for most applications where the 'Load value' can be calculated, see below), or by the '**dead weight**' calibration method.

When each channel is calibrated and zero is set, the calibration for the main hoist can be adjusted if necessary in two points setting the correction parameters for the main hoist (see below).

If any load cell or channel used in the main hoist detects an error, the weight values (gross and net) in the main hoist window will be replaced with an error text 'Error', unless the parameter 'Replacement channel' is set to a valid channel (see below).

Data sheet calibration of the Main Hoist

Every channel used by the Main Hoist should normally be calibrated using the '**data sheet**' method. See the G4 standard manuals on how this is done.

If each separate load cell in the Main Hoist is connected to an own channel in G4, then some values has to be calculated, and the value for 'Rated load' be adjusted according to the formula below, in order to have a correct data sheet calibration.

The values that has to be calculated is as follows:

Display value: How much of the total load on the Main Hoist that should be displayed by the separate load cell/channel.

Load value: How much of the total load on the Main Hoist that acts on the separate load cell.

When these values are calculated, the value for 'Rated load' that is entered in the data sheet calibration, should be adjusted as follows

$$\text{Rated load} = \text{Display value} / \text{Load value} * \text{load cell capacity}$$

In the parameter 'Rated output 1' the value for rated output in the data sheet for the load cell should be entered.

Below are three examples on how these values are calculated and used.

Example 1.

A crane with one rope package and two pulley wheels. Load cell is mounted in fixed rope end. The load cell will take the load in one of the six ropes, and shall display the total load in the hoist.

Display value: 100 % (1/1) The load cell shall display the total load

Load value: 16.67% (1/6) The load cell takes the load in 1 of 6 ropes

Rated load that should be entered into the data sheet calibration:

$$\text{Rated load} = (1/1) / (1/6) * \text{Load cell capacity} \Rightarrow 6 * \text{Load cell capacity}$$

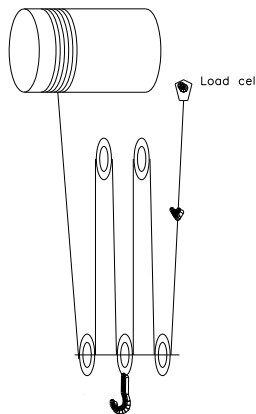

Figure 1

Example 2.

A crane with one rope package and two pulley wheels. The load cell is mounted in one of the pulley wheels. The load cell takes the load in two of the six ropes, and shall display the total load in the hoist.

Display value: 100 % (1/1) The load cell shall display the total load

Load value: 33,3 % (2/6) The load cell takes the load in 2 of 6 ropes

Rated load that should be entered into the data sheet calibration:

$$\text{Rated load} = (1/1) / (2/6) * \text{Load cell capacity} \Rightarrow 3 * \text{Load cell capacity}$$

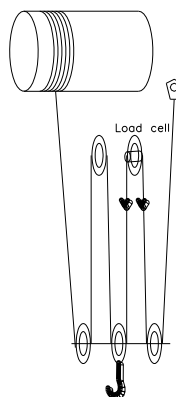

Figure 2

Example 3.

A crane with two rope packages with two pulley wheels each. Two load cells are mounted in one of the pulley wheels on each side. Each load cell is connected to its own channel in G4.

For each channel is:

Display value: 50 % (1/2) The load cell shall display half of the total load

Load value: 16.67% (2/12) The load cell takes the load in 2 of 12 ropes

Rated load that should be entered into the data sheet calibration:

Rated load = $(1/2) / (2/12) * \text{Load cell capacity} \Rightarrow 3 * \text{Load cell capacity}$

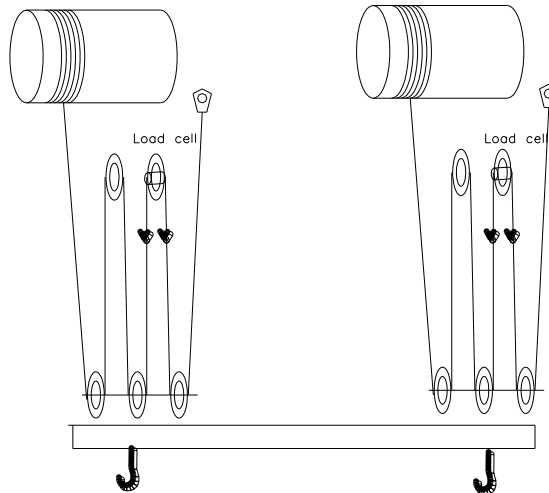

Figure 3

Dead weight calibration of the Main Hoist

In some cases a dead weight calibration is preferred instead of data sheet calibration. That is for example if all load cells in the Main Hoist is connected in parallel to one channel in G4, or if the 'Load value' is not possible to calculate.

If the Main Hoist has more than one load cell, each connected to its own channel in G4, a dead weight calibration of each channel can be done by lifting a known weight so that the load is spread equally over all load cells, e.g. if in figure 3 a 10 ton weight is lifted, it is important the each hook is loaded with 5 ton.

Then do a dead weight calibration on each channel in two points (0 and 5ton) by lifting the 10-ton weight in a similar way for the separate channels.

Adjusting the calibration for the Main Hoist

When each channel is calibrated and zero is set, the calibration for the Main Hoist can be adjusted in two points. See the parameters for the Main Hoist (menu 'Calibration' below).

Set-Up

Parameters

The menu system is reached with the 'Info' button when the indicator displays the separate channels (not in 'Main hoist' or 'Total Crane' window).
From 'Main hoist' window, press key 'Chan.1-8' and then key 'Info' (or key F11 on a connected USB keyboard).

Added or changed menus and parameters.

Menu 'General'

This menu has been extended with two new parameters. These are used only if option 15 'Mean value calculations' is activated

Mean Value Timeout

Range: 0 – 1200 s <120>	Defines the max time mean value calculations may be active. Default is 2 minutes.
-------------------------------	--

Mean Value Limits

Range: 0 – 100% <10>	Defines the limits as a percentage of the channels capacity. If current weight deviates more than this value from the mean value, the mean value calculations are automatically deactivated.
----------------------------	---

Menu 'Calibration'

This menu has been extended with a new sub menu '**Main hoist**'

Main Hoist

This sub menu consists of nine new parameters.

No of load cells in Main Hoist

Range: 0 – 8 <2>	Defines the number of channels that should be used for the Main Hoist. Channels that are used starts with channel no. 1 up to channel set in this parameter. When this is an even number, the first half of the channels are considered to be the 'left side' and the other half to be the 'right side' (when the number is odd, the last channel will be included in the right side).
------------------------	---

Capacity

Range: -999999 999999 <500>	Defines the capacity of the main hoist. This value is important when it is used for calculating the used 'Full Load Hours' (see 'Service information chapter')
--------------------------------------	---

The following three set-up parameters is used when option 16 'Rope weight compensation' is activated. They control whether rope weight compensation should be done, and in that case the factors for calculating the rope weight.

Rope Weight Compensation

Choices:: Off On <Off>	Defines whether 'Rope Weight Compensation' should be active for the main hoist.
---------------------------------	--

Rope Weight Factor 1

Range: -999999 999999 <0>	Defines number of pulses / scale division that is received from the incremental encoder counting the outrolled rope. This is the first factor, used when the input for factor selection (input 24) is inactive .
------------------------------------	--

Rope Weight Factor 2

Range: -999999 999999 <0>	Defines number of pulses / scale division that is received from the incremental encoder counting the outrolled rope. This is the second factor, used when the input for factor selection (input 24) is active .
------------------------------------	---

The following four set-up parameters, makes it possible to adjust the calibration for the main hoist. This is done by entering weight values in two different points.

Value in point 1 (normally 0)

Range: -999999 999999 <0>	Defines the actual load that is on the main hoist
------------------------------------	--

Read value in point 1

Range: -999999 999999 <0>	Defines the read value of the load that is on the main hoist. This parameter is automatically set by the system, when the value in the previous parameter 'Value in point 1' is entered. It may be changed manually.
------------------------------------	--

Value in point 2

Range: -999999 999999 <20>	Defines the actual load that is on the main hoist in the second point.
-------------------------------------	---

Read value in point 2

Range: -999999 999999 <20>	Defines the read value of the load that is on the main hoist in the second point. This parameter is automatically set by the system, when the value in the previous parameter 'Value in point 2' is entered. It may be changed manually.
-------------------------------------	--

Scale X

The configured channels (Scale 1 to Scale 8) in the menu 'Calibration' has been extended with two more parameter each.

Replacement channel

Choices:	Defines if the channel should use the weight of another channel.
Not in use	
1	Normally this parameter should be set in 'Not in use'.
2	It can be used if e.g. a load cell in the main hoist is broken and must temporary be removed. This channel
3	can then use the weight value from another channel by
4	setting this parameter to the channel that should be
5	used. If these channels normally had the same load, the
6	operation can continue until the load cell is replaced.
7	
8	The use of this is clearly indicated in the 'Main hoist'
<Not in use>	window, with the message 'WARNING, load cell simulated'

Full load hours

Choices::	Defines whether 'Full load hours' should be calculated
Off	for this channel or not.
On	
<Off>	

For the configured channels (Scale 1 to Scale 8) in the menu 'Calibration', the parameter 'Overload' has been removed (this parameter is not relevant in crane applications, when overload levels are controlled with the level functions, see 'Level supervision')

Note. The choices for 'WFIN Update rate' have been limited to 75 Hz and the choices for parameter 'HSWF Update rate' has been limited to 100 Hz.

Menu 'Communication'

The sub menu ('Serial Com.' has been extended with one new parameter.

Scale To Common Area

Choices:	To make it simpler to communicate for certain
Not in use	equipments e.g. radio equipments, a common area has
1	been created where any channels weight values can be
2	directed.
3	In this set-up parameter the channel that should be
4	directed to the common area is selected. See modbus
5	registers 40146-40160 and 44134- 44147 below.
6	
7	
8	
Main hoist (9)	
Left side (10)	
Right side (11)	
Left – Right (12)	
Sum all chan. (13)	
<1>	

Menu 'Level supervision'

The sub menus ('Level 1' to 'Level 32') have been extended with four new parameters each.

Level 'X' Level Value

Range:	Defines the level that is supervised. This level value can
-999999 - 999999	only be set in this set-up. It can be read by
<0>	communication and in other windows in G4.

Level 'X' Display Indicator

Range:	Defines if the level status indicator is displayed in 'Main
0 – 3	hoist' window, 'Total Crane' window or both.
<3>	0 = none, 1 = 'Main hoist' window
	2 = 'Total Crane' window, 3 = both

Level 'X' Delay

Range:	Defines the delay in ms before the level is activated
0 – 10000 ms	when the weight has gone above the set level value.
<0>	Allows for temporary dynamic overloads.
	Note. This parameter is only active if parameter 'Level X Max Value' is greater than parameter 'Level X Level Value'

Level 'X' Max Value

Range:	Defines the max value for the 'Level X Delay' parameter
-999999 - 999999	to be enabled. If the load exceeds the value, the delay is
<500>	disabled, and the level is acted on immediately.

The parameter 'Level X Scale' has been extended with five new choices.

Level 'X' Scale

Choices:	Five new choices:
Not in use	Main hoist: The level is compared with the main hoist weight value.
1	Left side: The level is compared with the left side weight value.
2	Right side: The level is compared with the right side weight value.
3	Left – Right: The level is compared with the difference between the left side and the right side.
4	Note. Use ' Abs.Gross Weight ' as choice in the 'Level X Source' parameter in order to always get a positive value.
5	Sum all chan.: The level is compared with the sum of all channels, that is 'Main hoist' + all other channels.
6	
7	
8	
Main hoist	
Left side	
Right side	
Left – Right	
Sum all chan.	
<1>	
	Remark: If any of above choices is selected, the parameter 'Level 'X' Source' must be set to 'Grossweight' or 'Netweight'

Note. Entering level value for the different levels is now done in this set-up menu, and under the 'set-up' password (if configured)

Menu 'Inputs'

The parameters for 'Inputs Slot 1' has been completely removed, when these inputs (input 11 to input 14) has been dedicated for 'Service Information' data for the 'Main hoist'. See chapter 'Service Information' below.

For all other inputs, the parameter 'Input XX Use' four new choices has been added

Input 'XX' Use

Choices:	Four new choices:
Not in use	Full load hours: This will cause 'Full load hours' to be calculated for the channel (configured in the following set-up parameter). Calculation is done when this input is active. The input 'active' time will also be gathered in the service information window for this channel.
Full load hours	Save statistic: This will cause all gathered statistic data to be saved to a file in the 'User' area of the file system.
Tare	Clear statistic: This will cause all gathered statistic data to be saved to a file (as above) and after that cleared.
Gross/Net	Calc Mean Value: When the input is activated (positive flank) the mean value calculations are started, and when the input goes from active to inactive (negative flank) the mean value calculations are stopped.
Gross	
Net	
Zero	
Flow/Weight	
Flow Rate	
Weight	
Save statistic	
Clear statistic	
Calc Mean Value	
<Not in use>	

Menu 'Analog outputs'

The sub menus ('Analog 1 Source' to 'Analog 4 Source') have a parameter 'AOUT 'X' Scale' that has been extended with four new choices.

AOUT 'X' Scale

Choices:	Five new choices:
Not in use	Main hoist: The analog output uses the main hoist weight value.
1	Left side: The analog output uses the left side weight value.
2	Right side: The analog output uses the right side weight value.
3	Left – Right: The analog output uses the difference between the left side and the right side.
4	Note. <i>The difference value might be either positive or negative.</i>
5	Sum all chan.: The analog output uses sum of all channels, that is 'Main hoist' + all other channels.
6	
7	
8	
Main hoist	
Left side	
Right side	
Left – Right	
Sum all chan.	
<1>	

Menu 'Program options'

This menu shows all available program options for this special program. In this program the options 'Crane weighing functions', 'Life cycle measurement' and 'Mean value calculations' are available as options.

Program options must be activated with an option code to be functional. The option code can be purchased from your instrument supplier.

13: Crane weighing functions

< - >	<p>The option code necessary to activate the 'Crane weighing functions'. The code always consists of 10 digits.</p> <p>To temporarily use the program option, enter the string 'Demo' (irrespective of upper/lower case). This will allow to use the option for 14 days e.g. for try out.</p> <p>Enter a '-' to turn off the program option.</p> <p>The program option can be used for several short periods but after a total use of 14 days it will be permanently turned off until a valid code is entered.</p>
-------	--

14: Life cycle measurement

< - >	The option code necessary to activate the 'Life cycle measurement functions' (similar to program option 13)
-------	---

15: Mean value calculations

< - >	The option code necessary to activate the 'Mean value calculations' functions' (similar to program option 13)
-------	---

Program options

A program option is a program functionality that must be purchased separately. It is not available until a valid option code is entered. An option code can be purchased at the same time as the instrument or separately at a later occasion. The program option code is directly related to the individual S/N of the CPU module. When ordering an option code it must be defined which CPU S/N it should apply to.

There is a possibility to use a program option for a limited time without an option code. This can be of use e.g. if the user would like to try out a program option, if a CPU is replaced and a new option code has not yet been acquired, etc.

Entering the text 'Demo' as the option code will give the user access to the program option during 14 days. After this period has expired a valid option code must be entered if the program option should be used. It is possible to disable demo mode if it is not used continuously. Entering a '-' instead of option code or 'Demo' will disable the program option. The 14-day period is only counted when demo mode is enabled. If the 14-day period has expired the text 'Demo Expired' is shown which indicates that the demo mode is no longer available.

In the sub menu 'Program Options' are all available program options shown.

In the special program described in this manual is 'Crane weighing' and 'Life cycle measurement' and 'Mean value calculations' are available as a program options.

In other standard programs and special program there might be other program options available.

If a program option is enabled in demo mode there will be an indication in the weight display. See below.

Chan. 1-8 *DEMO* 2006-09-24 19:07 ↓				
North side		052.8 t		
Gross				
South side		050.0 t		
Gross				
Aux 1		000.0 t		
Gross	Zero			
Aux 2		004.9 t		
Gross				
M. hoist	Total w.	P.Tare	Levels	-----

Demo mode indication

Communication

New Modbus Registers

Registers for the common area

Data type: Integer	Data type: float (2 reg./value)	Explanation	R/W
40146 (1 reg)	44134	Selected channel: Error	R
40147 (1 reg)	44136	Selected channel: Status	R
40148 (3 reg)	44138	Selected channel: Gross weight	R
40151 (3 reg)	44140	Selected channel: Net weight	R
40154 (3 reg)	44142	Selected channel: Flow	R
40157 (3 reg)	44144	Selected channel: In signal (mV/V)	R
40160 (1 reg)	44146	Selected channel: Scale number (1-13)	R

Registers for the hoist values

Data type: Integer	Data type: float (2 reg./value)	Explanation	R/W
41800 (1 reg)	45800	Main hoist: Error	R
41801 (1 reg)	45802	Main hoist: Status	R
41802 (3 reg)	45804	Main hoist: Gross weight	R
41805 (3 reg)	45806	Main hoist: Net weight	R
41808 (1 reg)	45808	Left side: Error	R
41809 (1 reg)	45810	Left side: Status	R
41810 (3 reg)	45812	Left side: Gross weight	R
41813 (3 reg)	45814	Left side: Net weight	R
41816 (1 reg)	45816	Right side: Error	R
41817 (1 reg)	45818	Right side: Status	R
41818 (3 reg)	45820	Right side: Gross weight	R
41821 (3 reg)	45822	Right side: Net weight	R
41824 (1 reg)	45824	Left side - Right side: Error	R
41825 (1 reg)	45826	Left side - Right side: Status	R
41826 (3 reg)	45828	Left side - Right side: Gross weight	R
41829 (3 reg)	45830	Left side - Right side: Net weight	R

Data type: Integer	Data type: float (2 reg./value)	Explanation	R/W
41832 (1 reg)	45832	Sum all channels: Error	R
41833 (1 reg)	45834	Sum all channels: Status	R
41834 (3 reg)	45836	Sum all channels: Gross weight	R
41837 (3 reg)	45838	Sum all channels: Net weight	R

Registers for 'Full Load Hours'

Data type: Integer	Data type: float (2 reg./value)	Explanation	R/W
41840 (3 reg)	45840	'Full Load Hours' Main hoist	R
41843 (3 reg)	45842	'Full Load Hours' Channel 1	R
41846 (3 reg)	45844	'Full Load Hours' Channel 2	R
41849 (3 reg)	45846	'Full Load Hours' Channel 3	R
41852 (3 reg)	45848	'Full Load Hours' Channel 4	R
41855 (3 reg)	45850	'Full Load Hours' Channel 5	R
41858 (3 reg)	45852	'Full Load Hours' Channel 6	R
41861 (3 reg)	45854	'Full Load Hours' Channel 7	R
41864 (3 reg)	45856	'Full Load Hours' Channel 8	R

Command register

28 new commands has been added to the command register (42000 or 46000)

Cmd	Action activated in instrument	Description
210	Start Timer 1	Same as input 11 activated
211	Stop Timer 1	Same as input 11 deactivated
212	Start Timer 2	Same as input 12 activated
213	Stop Timer 2	Same as input 12 deactivated
214	Start Timer 3	Same as input 13 activated
215	Stop Timer 3	Same as input 13 deactivated
216	Start 'Full Load Hours' Main hoist	Same as input 14 activated
217	Stop 'Full Load Hours' Main hoist	Same as input 14 deactivated
218	Start 'Full Load Hours' Chan. 1	Same as input for Chan. 1 activated
219	Stop 'Full Load Hours' Chan. 1	Same as input for Chan. 1 deactivated
220	Start 'Full Load Hours' Chan. 2	Same as input for Chan. 2 activated
221	Stop 'Full Load Hours' Chan. 2	Same as input for Chan. 2 deactivated
222	Start 'Full Load Hours' Chan. 3	Same as input for Chan. 3 activated
223	Stop 'Full Load Hours' Chan. 3	Same as input for Chan. 3 deactivated
224	Start 'Full Load Hours' Chan. 4	Same as input for Chan. 4 activated
225	Stop 'Full Load Hours' Chan. 4	Same as input for Chan. 4 deactivated
226	Start 'Full Load Hours' Chan. 5	Same as input for Chan. 5 activated
227	Stop 'Full Load Hours' Chan. 5	Same as input for Chan. 5 deactivated
228	Start 'Full Load Hours' Chan. 6	Same as input for Chan. 6 activated
229	Stop 'Full Load Hours' Chan. 6	Same as input for Chan. 6 deactivated
230	Start 'Full Load Hours' Chan. 7	Same as input for Chan. 7 activated
231	Stop 'Full Load Hours' Chan. 7	Same as input for Chan. 7 deactivated
232	Start 'Full Load Hours' Chan. 8	Same as input for Chan. 8 activated
233	Stop 'Full Load Hours' Chan. 8	Same as input for Chan. 8 deactivated
241	Clear statistic command	<i>Used to save and clear all gathered statistic data</i>
242	Start Mean value calculation	<i>If program option 15 is activated this command starts the 'Mean value calculations'</i>
243	Stop Mean value calculation	<i>If program option 15 is activated this command stops the 'Mean value calculations'</i>
244	Save statistic command	<i>Used to save all gathered statistic data to a file in the 'User' area in the file system</i>

Channel X: Status

Status for a channel.

Bits set to 1 in this register have the following meaning:

Bit 8, 9 and 10 has been added in this program.

Bit no	Function	Comment
0	Net weight > INT size	The net weight in 'scaled integer' format does not fit in one register. (See description of data representation.)
1	Gross weight > INT size	The gross weight in 'scaled integer' format does not fit in one register. (See description of data representation.)
2	Flow rate > INT size	The flow rate in 'scaled integer' format does not fit in one register. (See description of data representation.)
3	Good zero (disp. weight)	
4	Good zero Gross	
5	Good zero Net	
6	Net Mode	'1' = Net mode '0' = Gross mode
7	Motion	Unstable weight
8	Rope weight compensation	Rope weight compensation for main hoist is on
9	Weight simulated	One or more of the channels are using the function for simulated weight
10	Mean value calculation	Mean value calculations are running
11	Flow rate display	Flow rate is shown in the display.
12	Net weight > 6 digits	The net weight value is out of precision and should normally not be used.
13	Gross weight > 6 digits	The gross weight value is out of precision and should normally not be used.
14		
15		

Life Cycle Measurement (Option 14)

Service Information

General

This program adds functionality for gathering operational data. This includes supervising:

- Max. load on main hoist weights
 - max load on complete Main hoist
 - max load on left side of Main hoist
 - max load on right side of Main hoist
 - max difference in load between left and right side of Main hoist
 - Max. load on each separate channel
 - Max. load on sum of all channels (Main hoist + all other channels)
 - Total time activated for three different drives for the main hoist (digital input activated)
 - Total time activated for one drive (digital input activated) for each separate channel.
 - Number of activations (overload) for each of the 32 level functions
 - Total time activated (overloaded) for each of the 32 level functions
- Further to that also the 'Full Load Hours' are calculated, as described below.

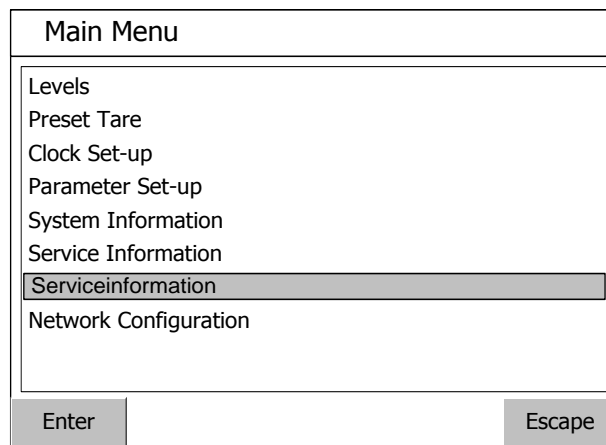

The 'Service information' menu is reached from the 'Main' menu (on PM/HE/DT versions only). The menu contains a number of windows containing the gathered data. Moving around the different windows is done with the buttons 'Next' and 'Previous' and escaping the 'Service information' menu is done with the 'Escape' button.

The information on each window can be resetted (zero'ed) with the 'Reset' button. A question will pop up asking if resetting is wanted. When resetted, the parameter 'Last resetted' will be updated with the current date and time.

In each window the button 'Save' will write all gathered data in all windows to a text file in the User area of the file system in G4. This file is named with the G4 instrument name and the current date and time.

For RM versions of G4 only the saved text file information is available. This file is created by activating a configured digital input or by sending a command via any serial communication.

‘General’ information window

Entering the ‘Service information’ menu will open the first window, where general data is shown.

Service Information				
General	Full Load Hours:	XXXXXX:XX (h:m)		
	Operating Time 1:	XXXXXX:XX (h:m)		
	Operating Time 2:	XXXXXX:XX (h:m)		
	Operating Time 3:	XXXXXX:XX (h:m)		
Max Load Main Hoist:	XXXXX,X	kg	YYYY-MM-DD	HH:MM
Max Load Left Side:	XXXXX,X	kg	YYYY-MM-DD	HH:MM
Max Load Right Side:	XXXXX,X	kg	YYYY-MM-DD	HH:MM
Max difference:	XXXXX,X	kg	YYYY-MM-DD	HH:MM
Max Load All Channels:	XXXXX,X	kg	YYYY-MM-DD	HH:MM
	Last Resetted:	YYYY-MM-DD HH:MM		
Prev.	Next	Save	Reset	Escape

In this window several data is displayed:

Full load hours:

This data is the accumulated calculated value of ‘Full load hours’. See the chapter ‘Full load hours’ below for a description on how this value is calculated and under what conditions. ‘Full load hours’ for main hoist are calculated when digital input 14 is activated

Operating Time X:

There are three digital inputs that can be used for measuring time purposes (e.g. measuring the time the hoisting motor is active or any of the other driving motors on a crane). The ‘Operating Time 1’, ‘Operating Time 2’, and ‘Operating Time 3’ timer is running when the corresponding digital input 11, 12, and 13 is active. The timer starts to run when the input gets activated, and the saved time is updated every minute until the input is deactivated.

Max load values:

There are four max weight values for the main hoist. This value is the maximum value that has been measured since this window was last resetted. Date and time when the max load occurred for each value is also shown. The values are:

- Max load total: Max load on the total main hoist
- Max load left side: Max load on the left side of the main hoist
- Max load right side: Max load on the right side of the main hoist
- Max difference (left-right): Max difference between left and right side

There is also a max weight value for all channels, that is Main hoist + all other channels.

- Max load all channels: Max load on Main hoist + all other channels.

'Channel X' information windows

On the next eight windows each separate channel info is displayed.

Service Information				
Channel X Information				
Channel Name : XXX...X				
Full Load Hours: XXXXXX:XX (h:m)				
Operating Time: XXXXXX:XX (h:m)				
Max Load: XXXXX,X kg YYYY-MM-DD HH:MM				
Last Resetted: YYYY-MM-DD HH:MM				
Prev.	Next	Save	Reset	Escape

For each of the possible 8 channels the following data is displayed.

Full load hours:

This data is the accumulated calculated value of 'Full load hours'. See the chapter 'Full load hours' below for a description on how this value is calculated. The 'Full load hours' are only calculated if the channel is configured for this and only when the configured input is activated.

Operating time:

This is the accumulated time the configured input has been activated.

Max load value:

This is the Max load value for this channel since last resetted. Date and time when the max load occurred is also shown.

'Level XX' information windows

For each of the available 32 levels, one window is showing information on respective level.

Service information				
Level XX				
Supervising Channel:	XXXXXX			
Current Level Value:	XXXXXX kg			
Number Of Times Activated:	XXXXX			
Total Time Activated:	XXXX:XX (h:m)			
Last resetted:	YY-MM-DD HH:MM			
Previous	Next	Save	Reset	Escape

The information shown is:

Supervising channel: This can be channel 1 – 8 or one of the main hoist channels ('Main hoist', 'Left side', 'Right side', or 'Difference')

Current level value: The current level value that is set for this level

Number of times activated: The no. of time this level has been above set level

Total time activated: The total time this level has been above set level

Full load hours

Full load hours are a calculated value that is calculated each weight sample and added to the corresponding value of 'full load hours'.

The 'Full load hours' value for the 'Main hoist' is calculated while the digital input 14 is activated, and the 'Full load hours' for the separate channels are calculated while the corresponding digital input configured for the channel is activated.

The formula for calculating the 'full load hours' is as follows

$$S = \sum k_m * t$$

Where:

S = 'full load hours'

$$k_m = \left(\frac{\text{current weight}}{\text{Capacity}} \right)^3$$

t = actual conversion time

current weight = actual current weight value

Capacity = Capacity for the actual channel (Main hoist or channel 1-8)
set as a set-up parameter

File handling

Two types of log files (text files) are created in the instrument.

The log files are stored in the instrument public memory (the "User" folder). This folder can hold roughly 5 Mbyte of data.

Every time the 'Save' button is pressed in 'Service Information' menu, or an instrument backup is taken, a new log file is created, and the available space for new data gets smaller.

The log files must be moved from the instrument memory to some external memory (e.g. a USB memory stick or an external PC memory), before the available space is too small. This is especially important when G4 type RM is used when log files can be lost if memory is overfilled.

For G4 type PM/HE/DT, the available space is checked on two levels by the program. If the available space is less than 1 Mbyte, a warning message is raised every 10th time a logging is done, telling the operator that the available space is small and he should consider moving files.

If the available space is less than 100 kByte, a warning message is raised every time a logging is activated, telling the operator the logging will not be done, since the available space is too small, and tells him to free up space by removing files.

Files can be handled either by the instrument internal file handling functions in menu 'Maintenance/file handling' where files can be copied, moved between folders or to a USB memory, or deleted

Files can also be handled with an ftp-session through the Ethernet port. Connect the ftp client (PC) to the IP-address of the G4 instrument and log in with user name 'G4User' and the password '1937' and you will open up the 'User' area of the memory in the instrument.

Backup files.

When a backup of the parameters in the instrument is done (in menu Maintenance/create backup), a text file is created together with the original xml file that is storing the parameters and used when restoring a complete setup. The new text file is named equal to the original file with an additional '.txt' extension. (Ex. Original backup name is 'G4_20090122_1545.bup' and the text file name 'G4_20090122_1545.bup.txt')

This text file lists all the set-up parameters and their values in the instrument in a more readable way than possible in the original xml file.

Service Information files.

These files contain all gathered statistical data from the 'Service Information' windows.

Example of a log file:

Crane 1067_20080211_081205.txt

```
Full Load Hours:      00006:29   (H:M)
Operating Time 1:     00001:01   (H:M)
Operating Time 2:     00000:00   (H:M)
Operating Time 3:     00000:00   (H:M)
Max Load Total:       1998.5    kg      2010-03-15 12:24
Max Load Left:        1095.0    kg      2010-03-15 12:24
Max Load Right:       903.5     kg      2010-03-15 12:24
Max Difference:       903.5     kg      2010-03-15 12:24
Max Load All Channels: 2008,5    kg      2010-03-15 12:24
Last resetted:        2008-02-08 08:45:53  □□
```

```
Channel No: 1
Channel Name:
Full Load Hours:      00000:00   (H:M)
Operating Time:       00000:00   (H:M)
Max Load:             0.0 kg      2010-03-15 12:24
Last resetted:        2008-12-11 13:46:21
```

Channel No: 2
Channel Name:
Full Load Hours: 0000:00 (H:M)
Operating Time: 0000:00 (H:M)
Max Load: 0.0 kg 2010-03-15 12:24
Last resetted: 2008-12-11 13:46:21

Channel No: 3
Channel Name:
Full Load Hours: 0000:00 (H:M)
Operating Time: 0000:00 (H:M)
Max Load: 0.0 kg
Last resetted: 2008-12-11 13:46:21

Channel No: 4
Channel Name:
Full Load Hours: 0000:00 (H:M)
Operating Time: 0000:00 (H:M)
Max Load: 0.0 kg
Last resetted: 2008-12-11 13:46:21

Channel No: 5
Channel Name:
Full Load Hours: 0000:00 (H:M)
Operating Time: 0000:00 (H:M)
Max Load: 0.0 kg
Last resetted: 2008-12-11 13:46:21

Channel No: 6
Channel Name:
Full Load Hours: 0000:00 (H:M)
Operating Time: 0000:00 (H:M)
Max Load: 0.0 kg
Last resetted: 2008-12-11 13:46:21

Channel No: 7
Channel Name:
Full Load Hours: 0000:00 (H:M)
Operating Time: 0000:00 (H:M)
Max Load: 0.0 kg
Last resetted: 2008-12-11 13:46:21

Channel No: 8
Channel Name:
Full Load Hours: 0000:00 (H:M)
Operating Time: 0000:00 (H:M)
Max Load: 0.0 kg
Last resetted: 2008-12-11 13:46:21

Level 1
Supervising Channel: 1
Current Level Value: 0 kg
Number Of Times Activated: 18
Total Time Activated: 00000:01 (H:M)
Last resetted: 2008-02-07 12:28:30

Level 2
Supervising Channel: 2
Current Level Value: 0 kg
Number Of Times Activated: 22
Total Time Activated: 00001:09 (H:M)
Last resetted: 2008-02-07 12:28:30

Level 3
Supervising Channel: 3
Current Level Value: 0 kg
Number Of Times Activated: 19
Total Time Activated: 00000:02 (H:M)
Last resetted: 2008-02-07 12:28:30

Level 4
Supervising Channel: 4
Current Level Value: 0 kg
Number Of Times Activated: 19
Total Time Activated: 00000:02 (H:M)
Last resetted: 2008-02-07 12:28:30

Level 5
Supervising Channel: Left side
Current Level Value: 0 kg
Number Of Times Activated: 21
Total Time Activated: 00001:05 (H:M)
Last resetted: 2008-02-07 12:28:30

Level 6
Supervising Channel: Right side
Current Level Value: 0 kg
Number Of Times Activated: 19
Total Time Activated: 00000:02 (H:M)
Last resetted: 2008-02-07 12:28:30

Level 7
Supervising Channel: Left-Right
Current Level Value: 0 kg
Number Of Times Activated: 21
Total Time Activated: 00001:07 (H:M)
Last resetted: 2008-02-07 12:28:30

Level 8
Supervising Channel: Main hoist
Current Level Value: 0 kg
Number Of Times Activated: 24
Total Time Activated: 00001:05 (H:M)
Last resetted: 2008-02-07 12:28:30

Level 9
Supervising Channel: 1
Current Level Value: 0 kg
Number Of Times Activated: 0
Total Time Activated: 00000:00 (H:M)
Last resetted: 2008-02-07 12:28:30

Level 10
Supervising Channel: 1
Current Level Value: 0 kg
Number Of Times Activated: 0
Total Time Activated: 00000:00 (H:M)
Last resetted: 2008-02-07 12:28:30

Level 11
Supervising Channel: 1
Current Level Value: 0 kg
Number Of Times Activated: 0
Total Time Activated: 00000:00 (H:M)
Last resetted: 2008-02-07 12:28:30

Level 12
Supervising Channel: 4
Current Level Value: 0 kg
Number Of Times Activated: 19
Total Time Activated: 00000:02 (H:M)
Last resetted: 2008-02-07 12:28:30

Level 13
Supervising Channel: 1
Current Level Value: 0 kg
Number Of Times Activated: 0
Total Time Activated: 00000:00 (H:M)
Last resetted: 2008-02-07 12:28:30

Level 14
Supervising Channel: 1
Current Level Value: 0 kg
Number Of Times Activated: 0
Total Time Activated: 00000:00 (H:M)
Last resetted: 2008-02-07 12:28:30

Level 15
Supervising Channel: 1
Current Level Value: 0 kg
Number Of Times Activated: 0
Total Time Activated: 00000:00 (H:M)
Last resetted: 2008-02-07 12:28:30

Level 16
Supervising Channel: 1
Current Level Value: 0 kg
Number Of Times Activated: 0
Total Time Activated: 00000:00 (H:M)
Last resetted: 2008-02-07 12:28:30

Level 17
Supervising Channel: 1
Current Level Value: 0 kg
Number Of Times Activated: 0
Total Time Activated: 00000:00 (H:M)
Last resetted: 2008-02-07 12:28:30

Level 18
Supervising Channel: 1
Current Level Value: 0 kg
Number Of Times Activated: 0
Total Time Activated: 00000:00 (H:M)
Last resetted: 2008-02-07 12:28:30

Level 19
Supervising Channel: 1
Current Level Value: 0 kg
Number Of Times Activated: 0
Total Time Activated: 00000:00 (H:M)
Last resetted: 2008-02-07 12:28:30

Level 20
Supervising Channel: 1
Current Level Value: 0 kg
Number Of Times Activated: 0
Total Time Activated: 00000:00 (H:M)
Last resetted: 2008-02-07 12:28:30

Level 21
Supervising Channel: 1
Current Level Value: 0 kg
Number Of Times Activated: 0
Total Time Activated: 00000:00 (H:M)
Last resetted: 2008-02-07 12:28:30

Level 22
Supervising Channel: 1
Current Level Value: 0 kg
Number Of Times Activated: 0
Total Time Activated: 00000:00 (H:M)
Last resetted: 2008-02-07 12:28:30

Level 23
Supervising Channel: 1
Current Level Value: 0 kg
Number Of Times Activated: 0
Total Time Activated: 00000:00 (H:M)
Last resetted: 2008-02-07 12:28:30

Level 24
Supervising Channel: 1
Current Level Value: 0 kg
Number Of Times Activated: 0
Total Time Activated: 00000:00 (H:M)
Last resetted: 2008-02-07 12:28:30

Level 25
Supervising Channel: 1
Current Level Value: 0 kg
Number Of Times Activated: 0
Total Time Activated: 00000:00 (H:M)
Last resetted: 2008-02-07 12:28:30

Level 26
Supervising Channel: 1
Current Level Value: 0 kg
Number Of Times Activated: 0
Total Time Activated: 00000:00 (H:M)
Last resetted: 2008-02-07 12:28:30

Level 27
Supervising Channel: 1
Current Level Value: 0 kg
Number Of Times Activated: 0
Total Time Activated: 00000:00 (H:M)
Last resetted: 2008-02-07 12:28:30

Level 28
Supervising Channel: 1
Current Level Value: 0 kg
Number Of Times Activated: 0
Total Time Activated: 00000:00 (H:M)
Last resetted: 2008-02-07 12:28:30

Level 29
Supervising Channel: 1
Current Level Value: 0 kg
Number Of Times Activated: 0
Total Time Activated: 00000:00 (H:M)
Last resetted: 2008-02-07 12:28:30

Level 30
Supervising Channel: 1
Current Level Value: 0 kg
Number Of Times Activated: 0
Total Time Activated: 00000:00 (H:M)
Last resetted: 2008-02-07 12:28:30

Level 31
Supervising Channel: 1
Current Level Value: 0 kg
Number Of Times Activated: 0
Total Time Activated: 00000:00 (H:M)
Last resetted: 2008-02-07 12:28:30

Level 32
Supervising Channel: 1
Current Level Value: 20 kg
Number Of Times Activated: 29
Total Time Activated: 00001:09 (H:M)
Last resetted: 2008-02-07 12:28:30

Connections for service information

Four digital inputs in slot 1 are dedicated for the three timers (drift1 to drift3) and for the full load hour calculations for the main hoist.

Drift1 accumulates time when digital input 11 is activated.

Drift2 accumulates time when digital input 12 is activated.

Drift3 accumulates time when digital input 13 is activated.

Full load hours for the main hoist are calculated when digital input 14 is activated.

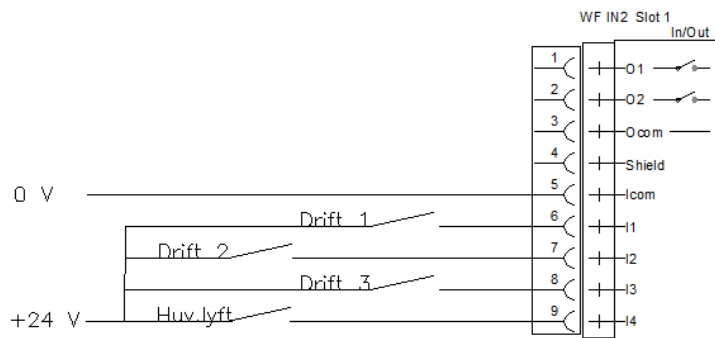
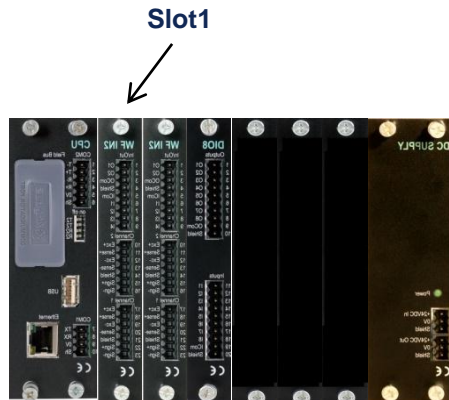

For the separate channels, any of the other inputs can be configured to accumulate time and calculate full load hours for resp. channel.

All timers and full load hour calculations can also be started and stopped by communication.

Mean value calculations (option 15)

When option 15 'Mean value calculations' is activated, a function is available that is especially useful when the crane is used for accurate weighing.

When the material that is going to be weighed has been lifted, you can start mean value calculation, which will rapidly give a stable weight value, even if the current value is varying around the correct value due to swinging load or other mechanical variations.

The mean value calculations can be started by pressing 'Start' button on front panel (or via a digital input, or via communication), and affects thereafter all weight values, that is the weight for the main hoist (also the different sides and the difference between the sides), all other channels weight values and the total weight in the crane (sum of all channels).

The calculated mean values are the weight values that are shown on the display, and the weight values that are communicated via communication or via analog outputs.

The mean value is calculated on the accumulated sum of all weight values from the time that the mean value calculation starts, until it stops. It is important that the mean value calculation is stopped before the weight in the crane is changed and then restarted when the new weight should be weighed, otherwise the new weight will have a very slow impact on the mean value.

Mean value calculation is stopped by pressing the 'Stop' button on the front panel (or via a digital input, or via communication). Mean value calculation is also stopped if the current load deviates more than the value set in parameter 'Mean value limits' as a percentage of the channel capacity (default value is 10%) from the mean value, or if it has been running more than the time set in parameter 'Mean value timeout' (default value is 120 s (or 2 minutes)).

The mean value is calculated on all channels, and it is therefore important that only one hoist is used when mean value is calculated, when a weight deviation above the limit in another hoist also will deactivate the calculations in all hoists (channels).

During the time mean value is calculated, this is indicated in the display by showing the weight value and unit in green color in PM,HE,DT versions of G4 and by displaying a 'L' next to the Gross/Net indicator ('G' or 'N') in the RM version of G4.

It is also indicated in the status register for each channel when communicating with the G4.

Remark. The calculated mean values does NOT affect the level supervision functions (overload indications), or the weight values used to collect data for the life cycle measurement. The current weight value is always used for these functions.

Rope Weight Compensation (option 16)

General

In a crane weighing application where the load cell is mounted so that the rolled out rope is affecting the weight, this option has functionality to compensate for the weight of the rolled out rope.

The effect on the weight of the rolled out rope is linear and can be compensated for if you know the length of the rolled out rope. Therefore an incremental encoder should be mounted on the crane that gives a pulse train to input I1 and I2 in Slot 2 in G4, as the rope rolls out or in. The encoder should be arranged so that the pulse train should give not more than 50 pulses/sec. In addition to that the G4 also needs a signal (digital input) when the rope is in a special calibration position (no rope rolled out). The option allows for two compensation factors, and which one is used is selected with a digital input.

Required inputs

The option requires the following inputs

Slot 2 Input I1 Pulse input 1 from incremental encoder

Slot 2 Input I2 Pulse input 2 from incremental encoder

Slot 2 Input I3 Active when in **rope calibration position** (no rope rolled out)

Slot 2 Input I4 If inactive, 'Rope weight factor 1' is used for compensation, and if active, 'Rope weight factor 2' is used.

Input connections

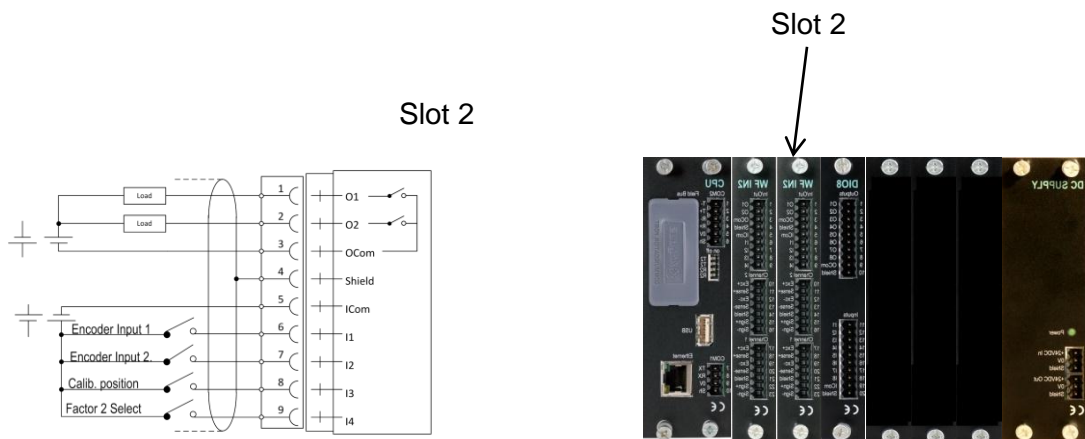

Input I1 Incremental encoder Input 1

Input I2 Incremental encoder Input 2

Input I3 Rope calibration position. Rope counter will be zeroed when this input is activated

Input I4 If not active, Rope Weight Factor 1 is used. If active, Rope Weight Factor 2 is used

Set-Up and Calibration of rope weight

The calibration of the weight should be done as described in the Crane weighing program manual. If dead-weight calibration method is used, the different known weights should be lifted to the same level in all calibration points used. After the weight calibration is ready, the zero should be set when the crane is in the rope calibration position (no rope rolled out). The 'set zero' function is only allowed in this position, while it is possible to tare the weight in all positions.

Two new set-up parameters for the rope weight compensation is added in menu 'Calibration/Main hoist' where the number of pulses/scale division is set. These parameters can be set manually by entering the value from the front panel, or it can be set automatically.

Automatic calculation of Rope weight factor (only in PM/HE/DT version)

Automatic setting of this parameter can be done when the window for entering the factor 'Edit: Rope Weight Factor X' is shown. This window has been extended to show also the current main hoist weight and the current value of the counter that counts the outrolled rope length.

1. Position the crane in the 'rope calibration position' (input I3 in Slot 2 activated).
Press the 'Start' key, (the key with the green start symbol)
It is essential that the weight is stable when this is done. The instrument records the weight and the counter value (green text at the right of the window),
2. Position the crane in another position (with much rope rolled out).
Press the 'Stop' Key(the key with the red stop symbol). Also at this time it is essential that the weight is stable. The instrument uses the current and saved weight values and counter values and calculates the Rope weight factor which is inserted into the edit field of the factor.
3. Press 'Enter' to save the new calculated parameter value 'pulses/scale division.

Manual calculation of Rope weight factor (used in RM versions)

In the RM version of G4 Rope weight factors must be calibrated manually.

1. Position the crane in the 'rope calibration position' (input I3 in Slot 2 activated).
With the '+' key select scale 9 to be shown on the lower row of the display.
The upper row shows normally the weight of the main hoist in this mode.
Pressing the '+' key again will force the display to show the rope counter in the upper row during 5 seconds in the format '* x..x *' (note the two stars around the counter value). Manually record the weight value (w1) and the counter value (c1).
2. Position the crane in another position (with much rope rolled out).
In the same way manually record the weight value (w2) and the counter value (c2).
3. Manually calculate the factor value that should be entered into the set-up parameter 'Rope We Fact X' with the formula

$$\text{RopeWeFactX} = (c2 - c1) / ((w2 - w1) / \text{scale division})$$

Enter the calculated 'RopeWeFactX' into the corresponding set-up parameter.

Operation with rope weight compensation activated.

The rope length is zeroed when the crane is positioned in the 'rope calibration position' (no rope rolled out). The G4 hereafter counts the pulses and compensates the Main hoist weight value with the calculated weight of the rolled out wire.

When normal operation and rope weight compensation is active a message is displayed in the 'Main hoist' window on the message line saying 'Rope weight active'.

After a power fail when the G4 is powered up and if the rope is not in the 'rope calibration position', the G4 remembers the last position of the rolled out rope and the compensation should still be correct, but in case the rope position has been changed during the power fail, a warning message will be displayed in the 'Main hoist' window displaying 'Note: Rope not zeroed after power on' until the rope comes to the 'rope calibration position', where the rope counter is zeroed.

Using keys 'F2' and 'F3' will display the calculated rope weight ('F2') or the current value of the rope counter ('F3') during 5 seconds.

In the RM version of G4 pressing the '+' key when main hoist weight (scale 9) is displayed will display the rope counter during 5 seconds.

Test

Test the rope compensation function by reading the weight value in any position, and then move to another position and read the weight value. If the rope weight parameter was set up correctly, then you should read the same weight value at different levels.

Upgrading software

This program is accumulating and saving data for 'Service Information' over long time. Data is saved in a power safe memory that keeps the data even if power to the G4 instrument is lost.

It is highly recommended to do a backup of the instrument and to save data in a file before starting the upgrade.

It might be of great importance that data is intact, even after a software upgrade. Because of that, the program is done in the way that when upgraded, a check is done to see if the structure of the saved data has been changed (the saved data cannot be used), and in that case a question is popped up asking the operator if saved data should be erased completely, or if he wants to try starting the instrument without erasing the data and eventually be able to use part of it (this is valid for G4 type PM/HE/DT). For G4 type RM, the memory is erased if the data structure has been changed.

Normally it is necessary to erase the memory when the data structure might have been changed.

After a software upgrade, it is necessary to do a 'default set-up' before setting up the instrument or restoring an earlier backup. This is done in the 'Maintenance' menu by selecting the 'Set default values' command.

Version history

This is a summary of function changes between the versions of this program. These changes are also all integrated in the manual text above.

G4MI_1.2.109.8

Option 16 'Rope weight compensation' has been added.

Added missed information in text file for parameter setup

If 'Replacement channel' used level functions on the faulty channel will still work with replacement channel value.

If 'Main hoist' only has one channel, don't calculate left, right and diff values.

G4MI_1.2.109.7

Not released version.

G4MI_1.2.109.6

Log and show date and time when max values occur (for all max values)

Add commands to command register to allow by communication start and stop timers and full load measurements.

Changed command 240 to 244 in order not to conflict with an error indication in field bus communication.

Corrected an error that could cause a lock up at an extreme (faulty) calibration and adjusting the main hoist cal.

G4MI_1.2.109.5

Option 15 has been added. Function for calculating mean value (when crane is used for weighing).

One new set-up parameter for each level function (32) that defines whether the level should be indicated in the Main hoist window, the Total weight window or in both

Program options (13,14,15) are named after functionality e.g. 'Crane weighing functions' instead of 'Special prog opt..X'

Preceding zeros in weight value on the display removed. Earlier min 3 digits before decimal point.

In the window where separate channel are displayed, an arrow next to date and time shows if there are more channels to scroll to (both upwards and downwards)

In the status register for each channel there is a bit indicating if the weight for the channel is simulated.

When creating a log file a check is done that the name only consists of allowed file name characters. If not allowed characters are found, they are replaced with an underscore '_' character.

Zeroing of 'Max load all channels' corrected.

Choice of time format is limited to 24 h mode.

Status indication of levels when weight error corrected.

G4MI_1.2.109.4

Program options code functionality has been included in order to activate the extra functions. Special Prog. Option 1, enables the functions for 'Crane weighing' and Special Prog. Option 2, enables the functions for 'Life cycle measurement.

Life cycle measurement for SWP analysis, can be done on each channel used (main hoist and also auxiliary hoists)

- New set-up parameter in 'Calibration' menu for each channel (1-8) 'Full load hours' can be set to 'On' if full load hours should be calculated for the channel (note that an input also has to be set for this channel)

- New choice 'Full Load Hours' for setting up parameter 'Input XX Use'. Setting this choice (and the channel no) defines the input, so full load hours for this channel is calculated when the input is active. The input is also used as a timer for selected channel.

- Eight new pages (one for each channel) in the 'Service information' menu are replacing the 'Max load channels' page in previous version. The new pages displays for each channel the channel name, the full load hours, operating time, and max load and last resetted date/time.
- All nine 'Full Load Hours' values (one for each channel + main hoist) are readable from any serial communication port as modbus registers.
- When in the 'standard' window where each separate channel is displayed, it is now possible to select to move to 'Main hoist' window or 'Total crane' weight window. Main hoist window shows the sum of the channel defined for the main hoist, while the 'Total crane' window shows the sum of all channels in the G4
- All timers are now updated roughly every minute (only when input deactivated in previous versions).
- In window for main hoist or total crane weight, when pressing button 'levels', all levels are displayed.
- When a backup is taken, a text file of all set-up parameters is also created (same name as backup file plus .txt at the end. A log file of all statistic data is also created.

G4MI_1.2.109.3

Editing the level values for the 32 level functions is moved in under the set-up menu Level Supervision\ Level X. The levels can still be read from comms and other windows in G4, but not edited.

A common modbus area has been created where any channels weight value can be directed.G4MI_1.2.109.2

Program made adaptable for use also in DIN rail mounted version of G4 (RM)

-It is possible to read the weight of the 'main hoist' in the Viewpan display:

The main hoist value is represented by scale 9 (S9:) Buttons 'Tare', 'Zero', and 'G/N' (gross/net) works as for the separate scales

-It is possible to give the commands 'Save statistic' and 'Clear statistic' via communication or via a configured digital input.

Level supervision functions improved.

-Added choice in 'scale' selection parameter 'sum of all channels' that makes it possible now to supervise the total load on all channels, that is the sum of the load in the main hoist and the additional auxiliary hoists.

-The level indicators now indicate the status of the relay connected to the level instead of whether the load is above or below the level.

-A new parameter has been added for each level. The parameter 'Max value' indicates the level where the set delay for that level is disconnected. That is if the load goes above 'max value' the relay is activated/deactivated immediately.

Some minor bugs corrected.

G4MI_1.2.109.1

Window header in window for chan. 1-8 added.

Bug in analogue output function corrected.

G4MI_1.2.109.0

Base version developed for G4 with graphical display (PM/HE/DT)

Document no. 35008
PG4MI_1_2_109_8_E1R0
© Vishay Nobel AB, 2011-12-28
Subject to changes without notice, set forth at www.vishaypg.com/doc?63999.

Vishay Nobel AB

Box 423, SE-691 27 Karlskoga, Sweden
Phone +46 586 63000 · Fax +46 586 63099
pw.eur@vishaypg.com
www.weighingsolutions.com