

G4 Multi Channel Weighing Instrument

Program version 1.2.0.0



Technical Manual

PM/DT/HE types

Contents

1. Introduction

General	1-1
Functions	1-2
Maintenance	1-3
Safety information	1-3
Technical data	1-4
Ordering information	1-12

2. Installation

Mechanical installation	2-1
Electrical installation	2-2
CPU unit	2-3
DC SUPPLY	2-5
AC SUPPLY	2-6
WF IN, WF IN2 and HS WF2	2-7
AOUT1 and AOUT4	2-10
DIO8	2-11
Profibus-DP Fieldbus Adaptor ..	2-12
DeviceNet Fieldbus Adaptor	2-14
Front panel	2-16

3. Set-up

General	3-1
Graphical touch display	3-2
Menu structure	3-6
Parameters	3-8

4. Calibration

General	4-1
Common parameters	4-2
Data sheet calibration	4-4
Table calibration	4-5
Deadweight calibration	4-5

5. Operation

General	5-1
Power supply	5-1
Power-up sequence	5-1
Display alt. by normal operation ..	5-2
Security locks	5-4
Taring	5-5
Gross/Net operation	5-6
Zero setting	5-6
Zero-track./Auto. zero setting	5-7
Motion	5-7
Main menu	5-8
Level supervision	5-10
Setpoint function	5-11
Use of inputs and outputs	5-12
Filter function	5-12
Flow rate	5-14

6. Communication

General	6-1
Serial interface	6-1
Modbus RTU Slave	6-1
Modbus TCP Slave	6-2
Modbus protocol	6-3
Fieldbus interface	6-29

7. Troubleshooting

General	7-1
Error codes	7-1

Appendix

Declaration of Conformity	App.1
---------------------------------	-------

PRECAUTIONS

READ this manual BEFORE operating or servicing this instrument.

FOLLOW these instructions carefully.

SAVE this manual for future reference.



WARNING

Only permit qualified personnel to install and service this instrument. Exercise care when making checks, tests and adjustments that must be made with power on. Failing to observe these precautions can result in bodily harm.

DO NOT allow untrained personnel to operate, clean, inspect, maintain, service, or tamper with this instrument.

1. Introduction

General

The G4 Instrument is a high performance multi channel weight indicator intended for industrial systems.

Its basic function is to convert the signals from strain gauge transducers to useful weight information. Transducer excitation is included as well as parameter controlled signal processing, indication of output levels, error supervision and operation of optional external equipment. The instrument can be equipped with up to 8 synchronized weighing channels.

The instrument is modular and can be equipped with different types of **I/O units** to match the demands in the specific applications. There are strain gauge transducer interface modules, a digital input/output module, and analog output modules. Internal solid-state outputs in the instrument can be used for output functions from level supervision, setpoints, etc. or 'In process' indication, reporting the operating status of the G4 Instrument.

The **CPU unit** in the instrument has several communication interfaces. It has two serial communication ports, an Ethernet port, an USB port and a fieldbus slot. Several G4 Instruments can be controlled from a master computer or PLC. Serial communication interfaces are RS-485 and RS-232 using Modbus RTU protocol. The Ethernet interface is using Modbus TCP and the optional fieldbus interface uses Profibus or DeviceNet.

It is possible to load new software into the instrument using the USB port.

All functions in the G4 Instrument are controlled by set-up parameters. Setting of parameter values can be performed with **keys** and/or **graphical touch display** on the front panel.

24 V DC or 110/230 V AC powers the G4 Instrument. All input and output signals are galvanically isolated from the power supply by operational insulation.

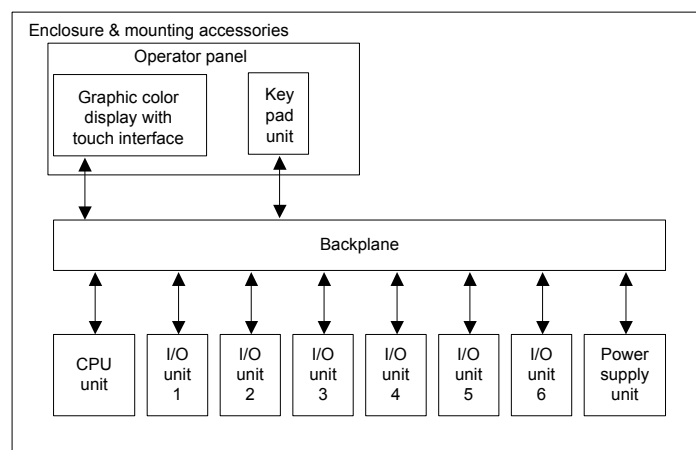

Block structure of a G4 Instrument

Functions

Measurement with strain gauge transducers.

Both excitation voltage and output signal are measured at the transducer to avoid influence from voltage drop in the connection cable. Excitation to the transducer, from the G4 Instrument is provided over separate wires. A shielded 6-wire cable must be used to connect a distant transducer to the instrument.

A/D conversion.

The analog signals from the transducer are converted to digital form and filtered to give an internal transducer signal with high resolution.

Calculation.

The transducer excitation and signal values are combined to form an internal transducer signal, representing the load on the transducer. Influenced by calibration data, this signal is converted to a digital measurement value, the weight value, which can be presented at the local display window and at external equipment.

Error supervision.

As long as the error supervision detects no error, the signal 'In process' is present but if an error is detected, 'In process' will be off and a specific error message will be displayed. 'In process' can be set to control any digital output. Note that there are weighing channel specific and instrument specific error detection.

Levels.

32 level comparators in the instrument can be set to switch at defined signal levels with any selected hystereses added, meaning that the switch level can be different for increasing and decreasing signal. Output signals from these comparators are available on the serial communication. The level comparator outputs can also be set to control digital outputs from the instrument.

Communication.

The G4 Instrument utilizes the serial interface, Ethernet and a fieldbus interface for communication with control computer. The serial interface consists of a RS-232 (COM1) connection and a RS-485/RS-422 (COM2) connection. COM2 can be used with 2- or 4-wire connection.

Weight values, level status, error status etc. can be collected and commands given through the communication interfaces. Modbus RTU protocol is used for the serial interfaces and Modbus TCP for the Ethernet connection. For the optional fieldbus interface Profibus or DeviceNet can be used.

Instrument modes.

In normal operation mode the G4 Instrument is presenting the measurement values on the front panel graphical display. One or more weighing channels can be shown simultaneously. The user can configure the display via set-up parameters. During parameter set-up the instrument will continue normal operation. However if hardware set-up parameters have been changed the instrument will be restarted. The operator will always be notified before the instrument is restarted.

Parameter setting.

In the instrument all operating functions are controlled by set-up parameters with numerical values, string values, or pre-selected values from a list of alternatives. Parameter set-up is performed by the keys at the front panel of the instrument and/or by using the buttons displayed on the touch display.

Presentation.

The instrument can present measured or calculated values, status of levels, parameter settings etc. at the front panel. An extensive system of menus gives the possibility to present various information about the instrument.

Measured or calculated values, status of levels and so on, can be transferred to external equipment via the different communication interfaces (some are optional).

Maintenance

The G4 instrument needs no maintenance, performed by the end-user. Any service or repair work must be performed by qualified personnel.

Contact your supplier.

Cleaning

Before cleaning the G4, break the power connection to the instrument.

Use a soft cloth to clean the exterior of the instrument. For cleaning the instrument front panel, a soft, damp, cloth may be used.

Safety information

Utilization.

Before connecting power to the instrument, check that all fixation screws at the modules are tightened so that the instruments functional grounding by the housing is maintained.

The instrument may only be utilized for the measurement and control functions, described in this Technical Manual. It is especially important to adhere to the load limits of the input/output connectors. We accept no responsibility for any damage arising from improper operation.

Any changes to the instrument, which causes any function changes, may only be carried out by the manufacturer, or after discussion with and permission by the manufacturer.

Meaning of symbols, used in this manual



Direct current.





Alternating current.



Caution, risk of danger. Documentation needs to be consulted.

Technical data

Enclosure types	PM - Panel mount	DT –Desktop	HE – Harsh Environment
			
Enclosure design	Aluminium housing, plastic panel	Aluminium housing, plastic panel	Stainless steel housing, plastic panel
Dimensions	See figure Panel thickness: 2 – 25 mm	See figure	See figure
Strain relief	—	6 pcs. for cable dia. 4.3 to 11.4 mm	6 pcs. for cable dia. 4.3 to 11.4 mm
Display	Color TFT LCD screen with backlighting, 5.7" 320x240 pixels		
Keyboard	Touch screen and 34 membrane keys		
<u>Environmental</u>			
Temperature range	Rated performance: -10 to +50 °C Storage: -25 to +85 °C		
Relative humidity	Max. 85% up to 40°C, decreasing linear to 50% at 50°C		
Rated pollution	Pollution degree 2	Pollution degree 3	Pollution degree 3
Protection	IP65 (panel), indoor use	IP65, indoor use. Rated for wet locations	IP65, indoor use. Rated for wet locations
Altitude	Up to 2000 m		
EMC, RF	CE (Industrial), OIML		

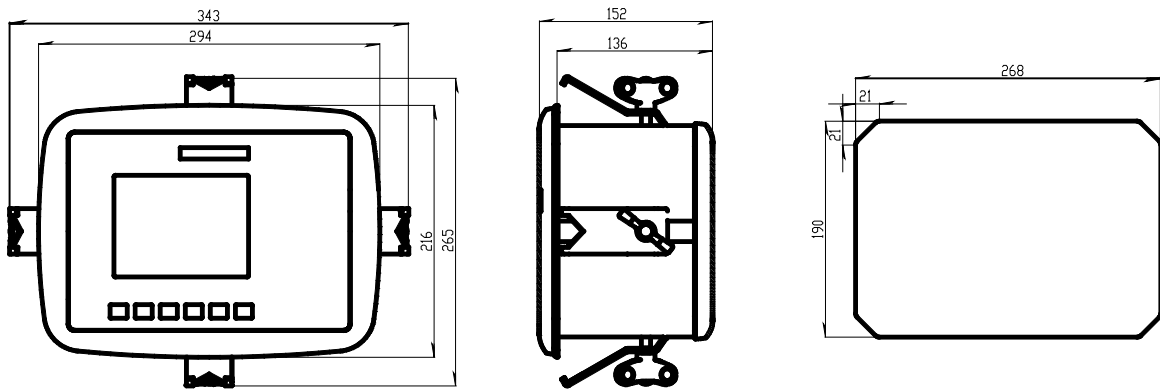

PM -Panel mount enclosure outlines and panel cutout.

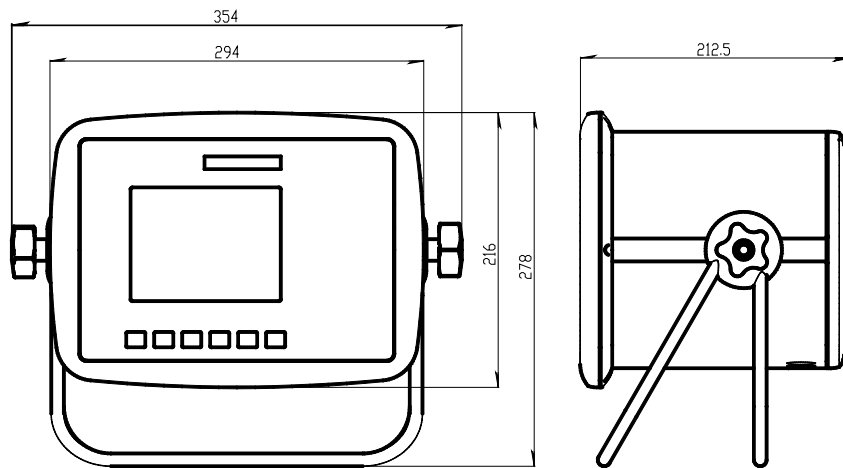

DT -Desktop enclosure outlines

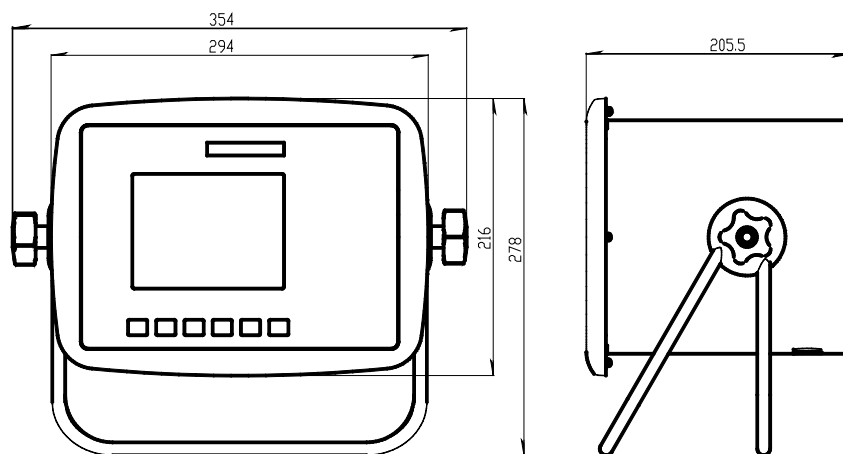

HE - Harsh environment enclosure outlines

CPU



Module type	CPU module		
RTC backup battery	Lithium battery CR2032 3V	<u>Manufacturer</u> Panasonic-BSG GP Batteries Varta	<u>Type</u> CR2032 CR2032 CR2032 (V)
COM1 (RS232) and COM2 (RS485)	For process data and control Isolated by operational insulation		
Protocol	Modbus RTU		
Baud rate	Up to 115 kbaud		
Fieldbus	For process data and control (optional)		
Types	Profibus or DeviceNet		
USB	Version 1		
Keyboard	USB keyboard for PC		
USB Memory	USB type for PC For backup and restore of set-up parameters For change to a new program version		
Ethernet	10/100BASE-T. For process data and control		
Protocol	Modbus TCP		

DC SUPPLY



Module type	Power supply module
Input	24 V _{DC} ±15% including fluctuations, 40W Impulse withstand (overvoltage) category I of IEC 60364-4-443
Output	24 V _{DC} output 0.1 A The same voltage as input voltage

AC SUPPLY

Module type	Power supply module
Input voltage	110-240 V~ +10% -15% including fluctuations, 50/60 Hz, 40W
Output voltage	24 V _{DC} output 0.1 A

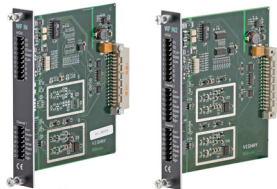
WF IN / WF IN2

Module type	Weight/Force input module
Max. # of transducers	8 (350 ohm) per channel Maximum 48 transducers per instrument
Excitation voltage:	5 VDC
A/D conversion:	3.9 kHz, 16 000000 units (24 bits)
Input range	+/- 7 mV/V
Update rate:	2.3 – 300 readings per second
No. of channels:	WF IN has 1 Weight/Force channel WF IN2 has 2 Weight/Force channels
Sensitivity:	0.1 μ V
Zero drift:	<10 nV/V/K
Span drift:	<2 ppm/K
Digital I/O	4 inputs, 24 V \pm 15%, 5 mA from external power supply, isolated by operational insulation and with common return 2 outputs, 24 V \pm 15%, max 100 mA from external power supply, isolated by operational insulation and with common return

HS WF2



Module type	High Speed Weight/Force input module
Max. # of transducers	4 (350 ohm) per channel
Excitation voltage:	10 VDC
A/D conversion:	20 kHz, 16 000000 units (24 bits)
Input range	+/- 4.5 mV/V
Update rate:	12.5 – 800 readings per second
No. of channels:	HS WF2 has 2 Weight/Force channels, separately isolated by operational insulation
Sensitivity:	0.1 μ V
Zero drift:	<10 nV/V/K
Span drift:	<2 ppm/K
Digital I/O	4 inputs, 24 V \pm 15%, 5 mA from external power supply, isolated by operational insulation and with common return 2 outputs, 24 V \pm 15%, max 100 mA from external power supply, isolated by operational insulation and with common return

DIO8



Module type	Digital input/output module
Separate I/O module	2 units can be used
Digital I/O	8 inputs, 24 V \pm 15%, 5 mA from external power supply, isolated by operational insulation and with common return 8 outputs, 24 V \pm 15%, max 100 mA from external power supply, isolated by operational insulation and with common return

AOUT1 / AOUT4



Module type	Analog output module
Number of channels	1 or 4 channels, separately isolated by operational insulation
Resolution	65000 units, 16 bits
Voltage output	0 – 10 V, -10 – 10 V, > 1 kohm load
Current output	4 – 20 mA, 0 – 20 mA, -12 – 20 mA, -20 – 20 mA, < 500 ohm load
Update rate	Scale update rate, adjustable smoothing filter

Profibus-DP



Module type	Profibus-DP fieldbus adaptor
Connector	Profibus 9-pin, female D-sub (DB9F)
Baudrate	Auto setting 9.6 kbps – 12 Mbps
Address	1 – 125, set by parameter
Fieldbus data	16 bytes from fieldbus to instrument. 32 – 244 bytes from instrument to fieldbus (may be limited by the master). See chapter '6 Communication' section 'Fieldbus communication interface' for details on fieldbus data mapping.
Mounting	The fieldbus adaptor is mounted through the front of the CPU module with LED's and connector accessible through the CPU front panel. Remove the plastic cover from the fieldbus slot in the CPU module front panel. Insert the adaptor very carefully and make absolutely sure that the adaptor slides correctly into the guides in the connector on the CPU PCB. Tighten the two fastening screws at the adaptor front and check that the two securing hooks locks into the CPU PCB.
Settings	All fieldbus settings are done with setup parameters in the instrument. No settings are done on the module itself.

DeviceNet



Module type	DeviceNet fieldbus adaptor
Connector	5 pin male connector.
Baudrate	125, 250, 500 kbps or Auto. Set by parameter.
Address	0 – 63, set by parameter
Fieldbus data	<p>16 bytes from fieldbus to instrument.</p> <p>32 – 244 bytes from instrument to fieldbus (may be limited by the master).</p> <p>See chapter '6 Communication' section 'Fieldbus communication interface' for details on fieldbus data mapping.</p>
Mounting	<p>The fieldbus adaptor is mounted through the front of the CPU module with LED's and connector accessible through the CPU front panel.</p> <p>Remove the plastic cover from the fieldbus slot in the CPU module front panel. Insert the adaptor very carefully and make absolutely sure that the adaptor slides correctly into the guides in the connector on the CPU PCB. Tighten the two fastening screws at the adaptor front and check that the two securing hooks locks into the CPU PCB.</p>
Settings	All fieldbus settings are done with setup parameters in the instrument. No settings are done on the module itself.
Bus Supply Voltage	According to the DeviceNet (Node) Specification: nominal 24 VDC, range 11 – 25 VDC.

Ordering information

For Panel mount (PM), Desktop (DT) and Harsh environment (HE) instruments

G4-PM-FB-S1-S2-S3-S4-S5-S6-P

	Instrument type		
PM	Enclosure type	PM DT HE	Panel mount Desktop Harsh environment
FB	Fieldbus interface	0 P D	None Profibus DeviceNet
Si	Slot 1 to 6 type	0 2 3 4 6 7 8	Blank HS WF2 High speed weight/force input module, 2 ch WF IN Weight/force input module, 1 channel WF IN2 Weight/force input module, 2 channels AOUT1 Analog Output module, 1 channel AOUT4 Analog Output module, 4 channels DIO8 Digital Input and Output module
P	Power supply	D A	DC power supply AC power supply (Not available at release of this manual)

Example: G4-PM-0-4-8-0-0-0-0-D

- G4 instrument (G4)
- Panel mount (PM)
- No fieldbus (0)
- Slot 1 = WF IN2 (4)
- Slot 2 = DIO8 (8)
- Slot 3 = Blank (0)
- Slot 4 = Blank (0)
- Slot 5 = Blank (0)
- Slot 6 = Blank (0)
- Power =DC supply (D)

Standard instruments:

Spec.no	G4 Type Code	Instrument configuration
110 563	G4-PM-0-4-0-0-0-0-0-D	G4 Panel mount, 1 WF IN2, DC Supply
110 564	G4-PM-0-3-0-0-0-0-0-D	G4 Panel mount, 1 WF IN, DC Supply
110 565	G4-PM-0-4-4-7-0-0-0-D	G4 Panel mount, 2 WF IN2, 1 AOUT4 DC Supply
110 566	G4-PM-0-2-2-8-0-0-0-D	G4 Panel mount, 2 HS WF2, 1 DIO8, DC Supply
110 567	G4-DT-0-4-0-0-0-0-0-D	G4 Desktop, 1 WF IN2, DC Supply
110 576	G4-DT-0-3-0-0-0-0-0-D	G4 Desktop, 1 WF IN, DC Supply
110 568	G4-HE-0-4-0-0-0-0-0-D	G4 Harsh environment, 1 WF IN2, DC Supply
110 577	G4-HE-0-3-0-0-0-0-0-D	G4 Harsh environment, 1 WF IN, DC Supply

Separate modules

Spec.no	Module type	Module name
110 544	CPU	CPU unit
110 546	HS WF2	High speed dual Weight/Force input module
110 547	WF IN	Single Weight/Force input module
110 548	WF IN2	Dual Weight/Force input module
110 549	AOUT1	Single channel analog output module
110 550	AOUT4	Four channel analog output module
110 551	DIO8	Digital input/output module
110 552	BLANK	Blank panel
110 553	DC SUPPLY	DC supply unit
110 559	PROFIBUS-DP	Profibus DP fieldbus adaptor
110 560	DEVICENET	DeviceNet fieldbus adaptor

Module selection rules

Every system needs 1 Power supply module and 1 CPU module (can be equipped with one fieldbus adaptor).

Limitations on number of I/O modules that can be used in one instrument:

- Maximum 6 modules.
- Maximum 4 WF IN / WF IN2 or 2 HS WF2 modules.
- HS WF2 and WF IN(2) cannot be mixed in the same system.
- Maximum 1 AOUT1 or 1 AOUT4 module.
- Maximum 2 DIO8 modules.

2. Installation

Mechanical installation

See section '1. Introduction – Technical data' for references to PM, DT and HE mechanical measures: outer extents, body extents and panel cutout (PM).

PM type instrument:

Make sure the panel thickness meets the specification and that there is room enough behind the panel for the instrument and the connected cables (minimum 200 mm).

Cut a panel opening according to the specification on page 1-5.

Insert the instrument through the opening. Hold it in place while attaching brackets and wing-headed bolts to the four nuts, sliding in grooves of the housing.

Tighten the bolts and make sure the integrated gasket of the instrument is compressed against the mounting panel, giving a sealed attachment.

DT and HE type instrument:

Arrange enough space for cables and strain reliefs behind or below the instrument.

DT instrument housings have 6 plugged openings facing downwards, intended for the cable strain reliefs. As an alternative, knock-out openings in the back panel can be knocked open for strain reliefs facing backwards.

HE instrument housings have 12 plugged openings for the cable strain reliefs, facing downwards and backwards.

Enclosed with each instrument is a set of 6 strain reliefs. For each cable one strain relief should be mounted with a sealing washer on the exterior and a locknut inside the housing.

Mounting legs are fitted to the instrument housings by knob-headed bolts and threaded holes or nuts. Use the enclosed fixing brackets to attach the legs to the table or a wall.

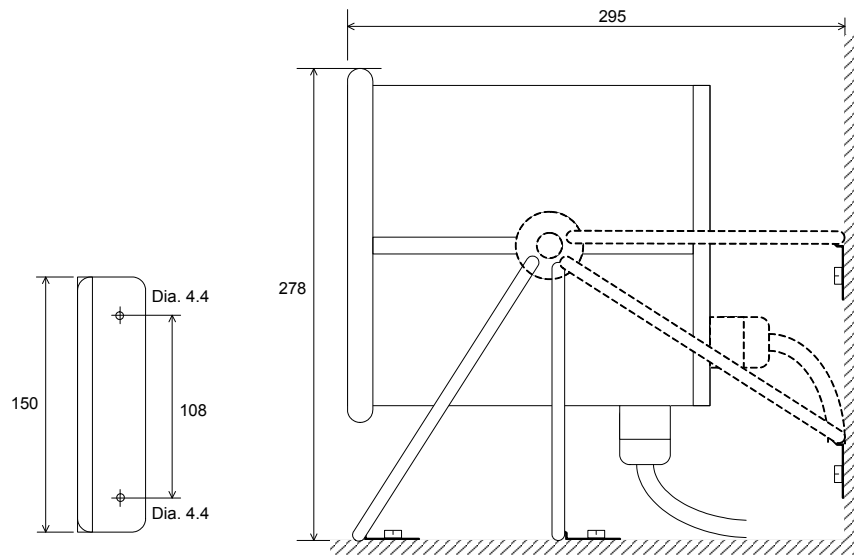

DT and HE instruments.

Fixing bracket, recommended distances to surrounding surfaces.

Electrical installation



The field wiring of the instrument shall be suitable to the environment (e.g. chemically) in the end-user application. Mains cables shall be separated and routed away from SELV or SELV-E field wiring.

For DT and HE instruments UL Listed and KAM cord type flexible cables shall be used. The cable diameters must be selected in accordance with the strain relief specification. See Technical Data.

Field wiring installation shall comply with any national regulations, hereunder National Electrical Code (NEC) for US and/or Canadian Electrical Code for Canada.

- A switch or circuit-breaker shall be included in the building installation.
- The switch shall be in close proximity to the equipment and within easy reach of the operator
- The switch shall be marked as the disconnecting device for the equipment.
- The equipment switch or circuit-breaker employed as disconnecting device shall comply with relevant requirements of IEC 60947-1 and IEC 60947-3.

The power supply for the instruments can be an external DC source and an internal DC SUPPLY unit or external AC mains and an internal AC SUPPLY unit.

For electrical installation with an internal DC SUPPLY unit, see page 2-5.

For electrical installation with an internal AC SUPPLY unit, see page 2-6.

WARNING

Make sure that the power to the instrument is turned off before:

- *any modules are removed from or inserted in the instrument.*
- *any connections are connected to or disconnected from the instrument.*

All modules should be regarded as ESD sensitive. Make sure that an ESD safe environment is maintained when inserting modules, removing modules and when handling modules separately from the instrument. Modules must be kept in metallised ESD bag when not mounted in the instrument.

CPU unit

External computing devices connected to the CPU communication interfaces of the instrument have to comply with the standard, UL 60950.

The internal battery in the CPU module is to be used only in the equipment where servicing of the battery circuit and replacement of the lithium battery will be done by a trained technician.



COM1

RS232 Serial communication.

This is a SELV/SELV-E circuit. COM1 can be used for serial communication with computer/PLC (Modbus RTU).

Point to point communication, only one G4 unit connected to the computer/PLC.

Connections are made to terminals 7 – 9. Shielded cable must be used. Connect shield to terminal 10.

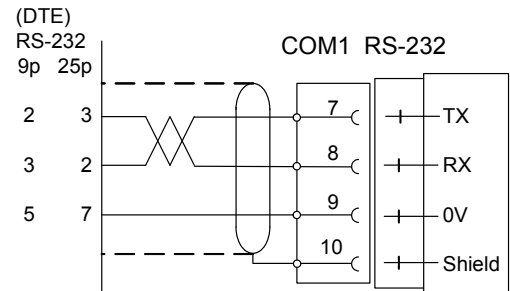

COM2

RS485 Serial communication for 2-wire or 4-wire with common 0 V.

This is a SELV/SELV-E circuit.

COM2 can be used for serial communication to computer/PLC (Modbus RTU).

Connections are made to terminals 1 – 5. Shielded cable must be used. Connect shield to terminal 6.

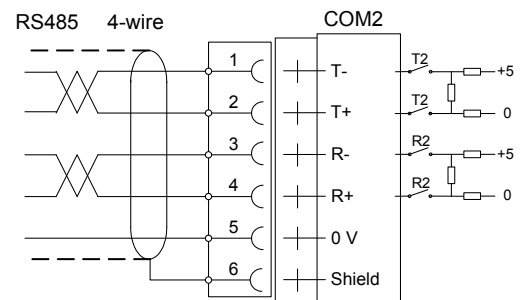
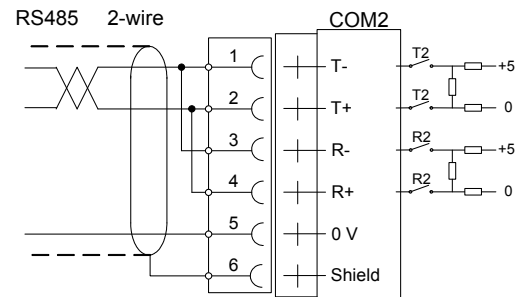

The communication lines must be terminated in both ends. If G4 is connected at the end of the communication line switches must be set as:

2-wire termination: Both T2 ON, both R2 OFF.

4-wire termination: Both T2 ON, both R2 ON.

Field Bus

Slot for optional Fieldbus interface

Profibus DP-V1 and DeviceNet are available.

See section Profibus-DP Fieldbus Adaptor or DeviceNet Fieldbus Adaptor later in this chapter for details.

USB

Connector for USB device(s).

This port has no operational insulation and should be considered as a SELV/SELV-E circuit.

Allows connection of following devices:

1 - USB Memory

2 - USB Keyboard

An USB Hub can be used to allow connection of more than one device.

Ethernet

This is a SELV circuit. Uses crossover category 5 cable from RJ-45 Ethernet port on the CPU front panel to PC (point to point connection) or standard cable to connect to other equipment through a switch, hub or router which is isolating the circuit from the public network.

DC SUPPLY 24 V_{DC} Power supply unit

The output of the external DC source must be rated 24 V_{DC}, ±15% including fluctuations, min. 40 W. The DC source must provide Double Insulation between Mains parts and 24 V SELV or SELV-E Circuit, and a limited-energy circuit (maximum available current of 8 A).

For the US market this energy limit can be achieved with an ANSI/UL248-14 fuse rated 5A.

For other markets an IEC 60127 T type fuse rated 4A may also be used.

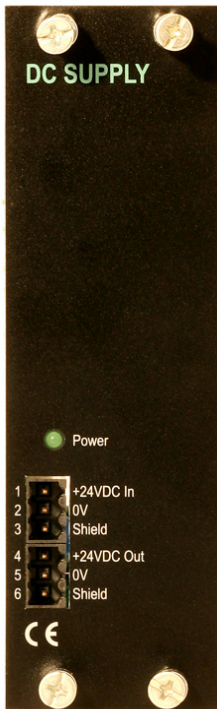

24 V_{DC} In

Terminals 1, 2 and 3.

The G4 instrument should be powered by 24 V_{DC}, connected according to the diagram below.

To achieve functional grounding, terminal 3 should be connected to ground.

See Technical data for input voltage ratings.

24 V_{DC} Out

Terminals 4 and 5 can be used to supply max. 100 mA to digital inputs and outputs.

Connection should be according to the diagram below.

See technical data for ratings.

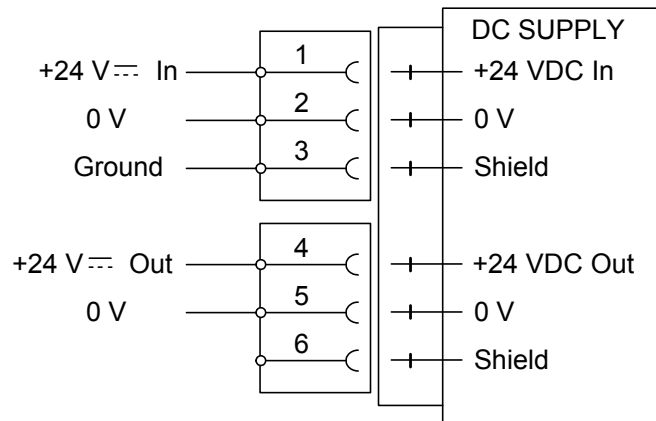

AC SUPPLY – 110-240 V~ Power supply unit



Mains supply cable shall be separated and routed away from SELV or SELV-E field wiring.

Remove power before removing the module from the instrument.

Make sure the fixation screws are well tightened during operation.



110-240 V~ In

Terminals 1, 2 and 3.

The AC SUPPLY gives the possibility to power the instrument from 110-240 VAC, connected according to the diagram below.

To achieve protective grounding, terminal 3 should be connected to protective earth.

See Technical data for input voltage ratings.

24 V \equiv Out

Terminals 4 and 5 can be used to supply max. 100 mA to digital inputs and outputs.

Connection should be according to the diagram below.

See technical data for ratings.

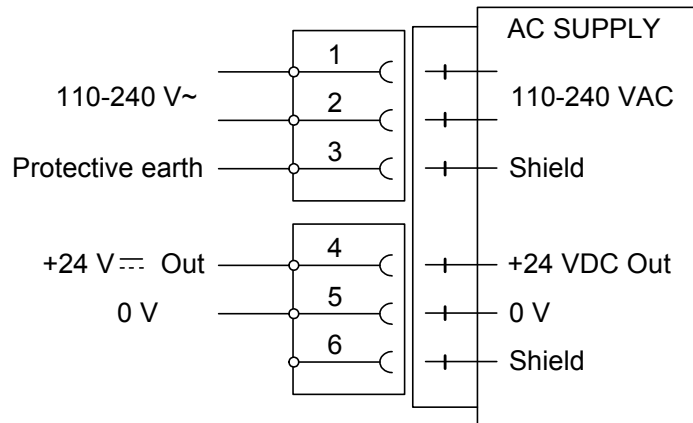

WF IN, WF IN2 and HS WF2

The voltage levels on connectors of I/O modules shall not exceed hazardous voltage levels of 30 Vrms, 42.4 Vpeak or 60 Vdc under normal conditions. In wet locations these voltage levels shall not exceed 16 Vrms, 22.6 Vpeak or 35 Vdc.

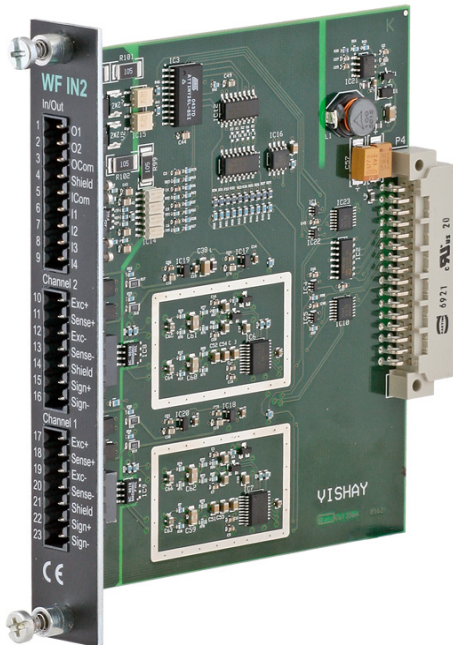

Transducer inputs

Terminals 17 – 23 (channel 1),
10 – 16 (channel 2).

Transducer connection should be handled with great care to achieve good measuring data. Transducer integrated cables may not be shortened.

NOTE! Transducer cables must be routed at least 200 mm away from 230/400 V, 50/60 Hz power cables. By cables with other frequencies or high power, an even wider distance is preferable.

4-wire connection can be used if the transducer integrated cable is long enough to be connected directly to a transducer input. At 4-wire connection, some terminals must be interconnected as shown in figure on next page.

6-wire connection should be used if the integrated cable must be lengthened or if several transducers should be connected to one transducer input.

The channel 1 cable shield must be connected to terminal 21 and the channel 2 cable shield must be connected to terminal 14.

In WF IN and WF IN2 the shield terminals are internally connected to the G4 housing, which is internally connected to earth via the power supply connector pin 3 (shield). The shield shall not be connected at any other point.

In HS WF2 the transducer input channels are separately insulated by operational insulation and the shields can be connected to the most convenient ground/earth point. This can be the junction box when using multiple transducers or at the barrier ground when using Ex zener barriers.

In the junction box SL-4 from Nobel Weighing Systems, see figure, all necessary terminals and interconnections are provided.

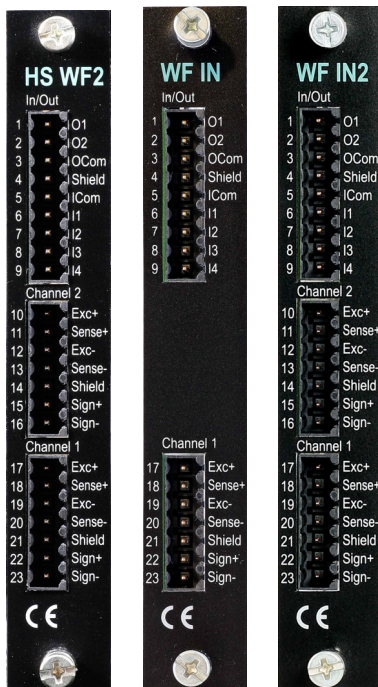

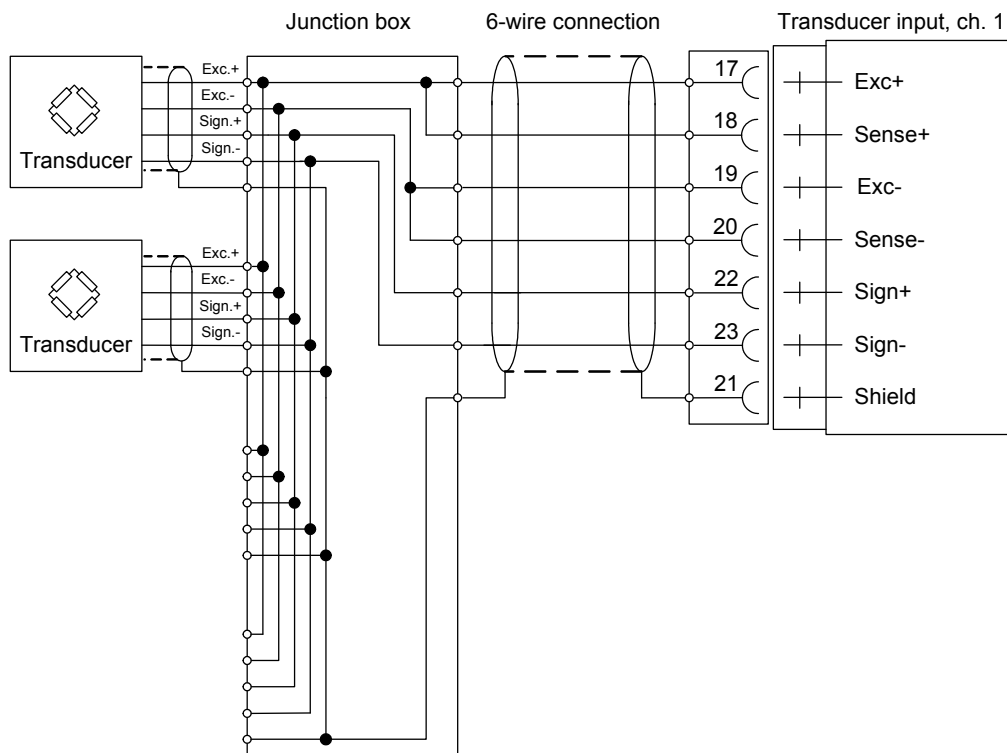
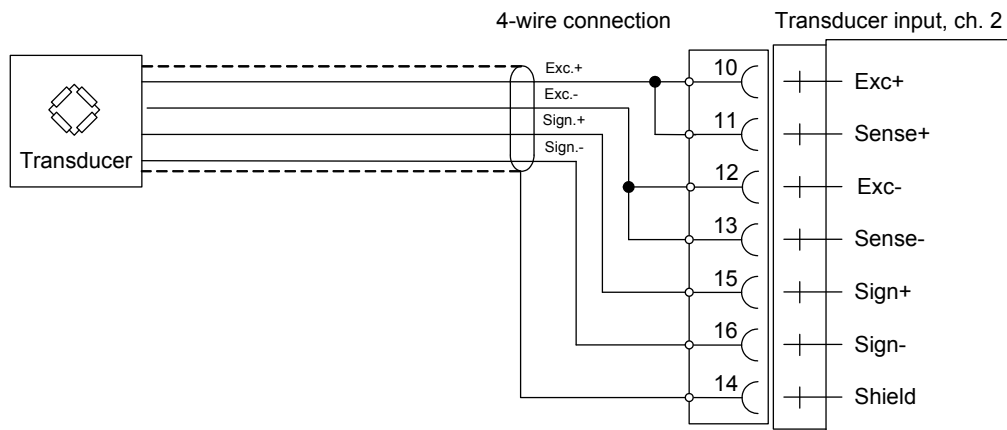

A transducer may be connected directly to terminals at the transducer input.

For several transducers or long distance, a junction box and lengthening cable is needed.

For a HS WF2 channel, the shield can be connected to ground/earth at any point

Digital inputs

Terminals 6 – 9 and terminal 5 (ICom) as a common connection.

Four digital inputs are provided, with functions that can be set in the G4 set-up. External sourcing (24 V $\overline{\text{---}}$) from the instrument power supply (max. 100 mA) or from a separate DC supply must be used. Note that either the positive or the negative pole of the voltage source (24 V $\overline{\text{---}}$) can be connected to ICom (5).

Shielded cable/cables must be used, with the shield connected to terminal 4.

Solid state relay outputs

Terminals 1 and 2 with terminal 3 (OCom) as a common connection.

Two digital (relay) outputs are provided with contact rating given in Technical data. External sourcing (24 V $\overline{\text{---}}$) from the instrument power supply (max. 100 mA) or from a separate DC supply should be used. Note that either the positive or the negative pole of the voltage source (24 V $\overline{\text{---}}$) can be connected to OCom (3).

Shielded cable/cables must be used, with the shield connected to terminal 4.

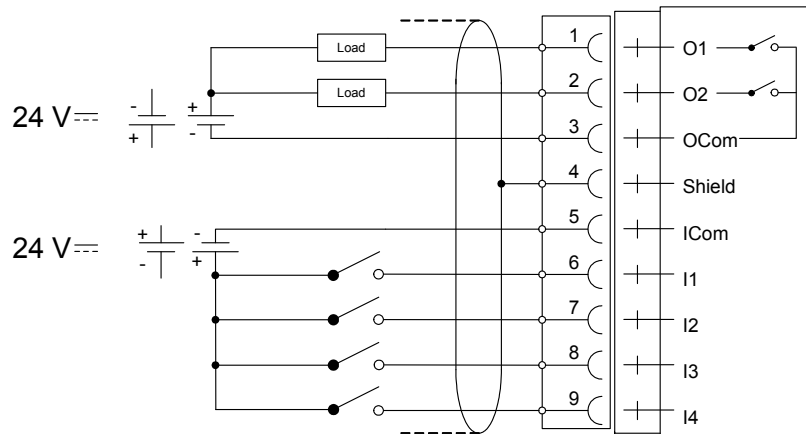

AOUT1 and AOUT4



The voltage levels on connectors of I/O modules shall not exceed hazardous voltage levels of 30 Vrms, 42.4 Vpeak or 60 Vdc under normal conditions. In wet locations these voltage levels shall not exceed 16 Vrms, 22.6 Vpeak or 35 Vdc.

Analog output unit

The AOUT4 unit has 4 analog output channels, independently isolated by operational insulation.

The AOUT1 has 1 output channel, isolated by operational insulation.

The analog output signal will be connected to terminals
 10, 11 (channel 1)
 7, 8 (channel 2)
 4, 5 (channel 3)
 1, 2 (channel 4).

Shielded cable/cables must be used and the shield(s) must be connected to the shield terminal(s) 12, 9, 6 and 3.

The shields can be connected to the most convenient ground/earth point

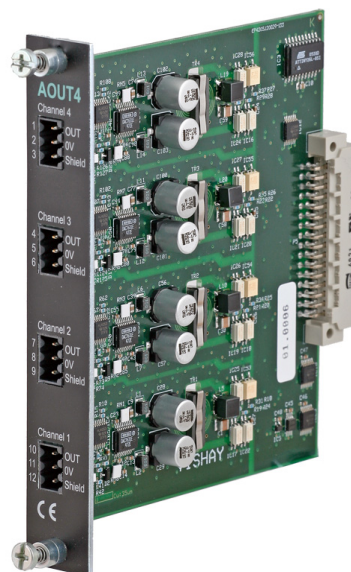
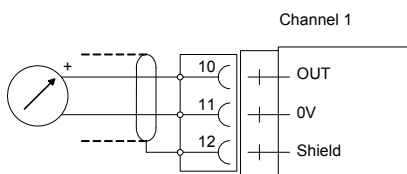
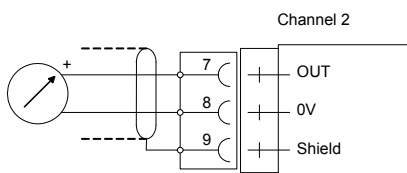
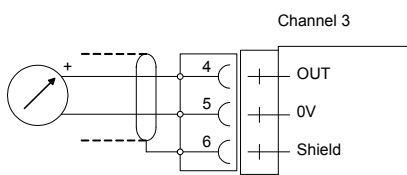
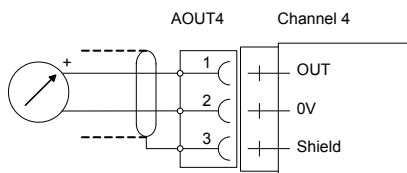
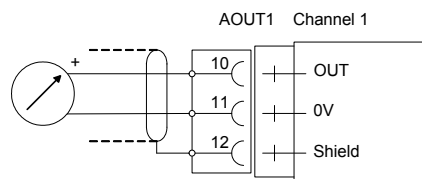

DIO8

The voltage levels on connectors of I/O modules shall not exceed hazardous voltage levels of 30 Vrms, 42.4 Vpeak or 60 Vdc under normal conditions. In wet locations these voltage levels shall not exceed 16 Vrms, 22.6 Vpeak or 35 Vdc.



Digital inputs

Terminals 11 – 18 and terminal 19 (ICom) as a common connection.

Eight digital inputs are provided, with functions that can be set in the G4 set-up.

External sourcing (24 V \equiv) from the instrument power supply (max. 100 mA) or from a separate DC supply must be used.

Note that either the positive or the negative pole of the voltage source (24 V \equiv) can be connected to ICom (19).

Shielded cable/cables must be used, with the shield connected to terminal 20.

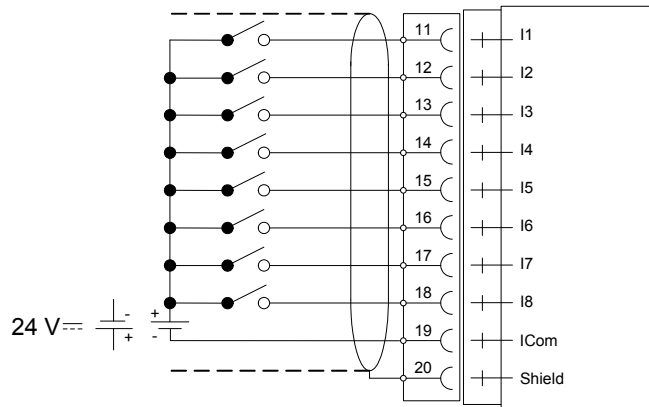

Solid state relay outputs

Terminals 1 - 8 with terminal 9 (OCom) as a common connection.

Eight digital (relay) outputs are provided with contact rating given in Technical data.

External sourcing (24 V \equiv) from the instrument power supply (max. 100 mA) or from a separate DC supply should be used. Note that either the positive or the negative pole of the voltage source (24 V \equiv) can be connected to OCom (9).

Shielded cable/cables must be used, with the shield connected to terminal 10.

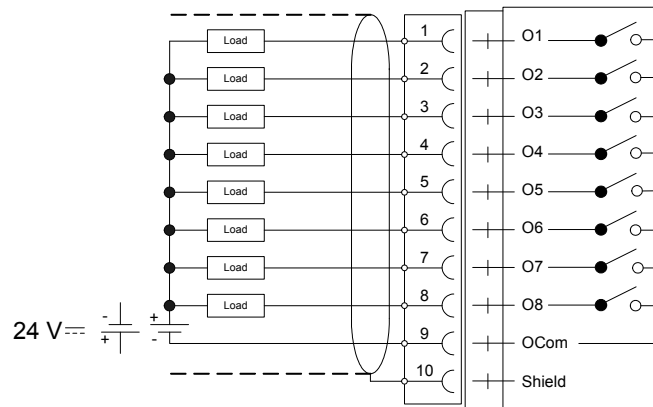

Profibus-DP Fieldbus Adaptor

Profibus module front view

- (1) Operation mode LED.
- (2) Status LED.
- (3) Profibus connector.

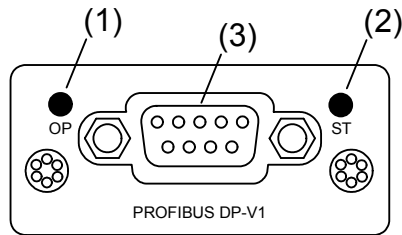

Operation mode LED

State	Indication
Off	Not online / No power
Green	On-line, data exchange
Flashing Green	On-line, clear
Flashing Red (1 flash)	Parameterization error
Flashing Red (2 flashes)	Profibus configuration error

Status LED

State	Indication
Off	No power or not initialised
Green	Initialised
Flashing Green	Initialised, diagnostic event(s) present
Red	Exception error

Profibus connector (DB9F)

Pin	Signal	Description
1	-	-
2	-	-
3	B line	Positive RxD/TxD, RS485 level
4	RTS	Request to send
5	GND Bus	Ground (isolated)
6	+ 5V Bus Output	+5V termination power (isolated)
7	-	-
8	A line	Negative RxD/TxD, RS485 level
9	-	-
Housing	Cable shield	Internally connected to the Anybus protective earth via cable shield filters according to the Profibus standard.

For connection of the adaptor to the Profibus master, use a Profibus standard cable and connector according to the diagram below.

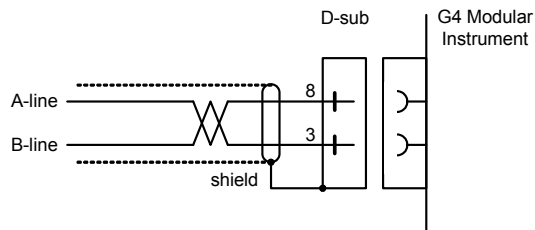

For reliable fieldbus function, line termination must be arranged in both ends of the transmission line. For a G4 instrument, at the end of the cable, a connector with line termination should be used. For all other G4 Instruments connection without line termination should be used.

For configuration of the adaptor, a GSD file (VISH0AB3.GSD) is available and should be installed in the master.

DeviceNet Fieldbus Adaptor

DeviceNet module front view

- (1) Network Status LED.
- (2) Module Status LED.
- (3) DeviceNet connector.

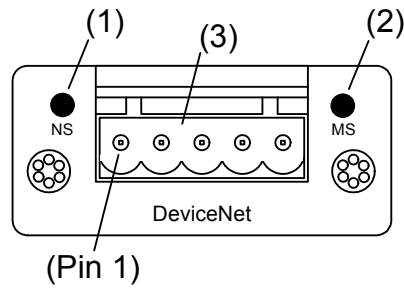

Network Status LED

State	Indication
Off	Not online / No power
Green	On-line, one or more connections are established
Flashing Green (1 Hz)	On-line, no connections established
Red	Critical link failure
Flashing Red (1 Hz)	One or more connections time out
Alternating Red/Green	Self test

Module Status LED

State	Indication
Off	No power
Green	Operating in normal condition
Flashing Green (1 Hz)	Missing or incomplete configuration
Red	Unrecoverable fault(s)
Flashing Red (1 Hz)	Recoverable fault(s)
Alternating Red/Green	Self test

DeviceNet connector

Pin	Signal	Description
1	V-	Negative bus supply voltage
2	CAN L	CAN low bus line
3	Shield	Cable shield
4	CAN H	CAN high bus line
5	V+	Positive bus supply voltage

For connection of the adaptor to the DeviceNet master, use a standard cable for DeviceNet, or similar shielded cable with twisted pairs and a connector according to the diagram below.

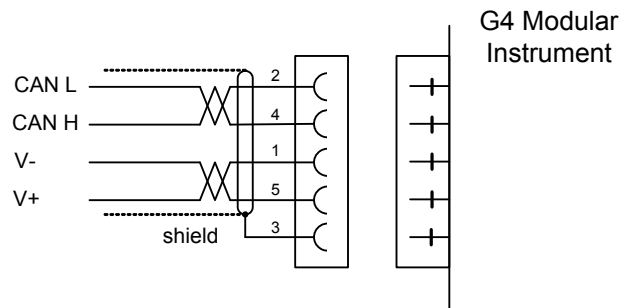

For reliable fieldbus function, line termination must be arranged in both ends of the transmission line. For a G4 Instrument placed at the end of the line, terminate line by placing a 121-ohm resistor between CAN L (pin 2) and CAN H (pin 4).

For configuration of the adaptor an EDS file is supplied with the instrument that should be installed in the master. Note that the EDS file is a generic type supplied by the module manufacturer. The file doesn't contain any reference to the G4 Instrument or to Nobel Weighing Systems.

Front panel

Display

At normal operation the instrument displays weight value(s) and, in some cases, the gross weight as a graphic bar.

Presentation, together with the weight value, of preset tare, status for the level supervision can also be selected in Parameter Set-Up.

If an instrument error occurs, the weighing function is stopped and the instrument switches over to Error mode, indicating a code for the error at the display window.

If there is a scale error this is indicated with error information that replace the weight information on the screen for that specific scale only, other scales are not affected.

The instrument can also display a Main menu with sub menus for display of actual data and entry of new data.

Function keys





Just below the display there are five function keys, F1 to F5, and with the actual key functions indicated at the lower line of the display. When there is no text above a key, that key has no function. To select a function, press the membrane panel button (F1 to F5) below the display or the button symbol on the touch display.

Symbol keys

At the bottom of the front panel there are four keys, marked with the weighing symbols for taring, gross/net, printing and zeroing plus two keys marked start and stop. A brief description of these keys is given in the table below.

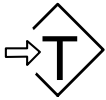

Front panel of the G4 instrument with color touch display, five function keys below the display, six application specific keys, numerical keypad, joystick keypad (arrow keys), Esc, Alt, Backspace, Delete, Tab and ENTER keys. In addition there is an Info key that is used to access the instruments menu system.

Key	Name	Function
	TARE	Taring, i.e. entry of the gross weight as auto tare value and display of net weight zero. Depending on actual setting taring may be prevented if 'Motion' is displayed. Note that a specific scale must be selected since the instrument can have multiple scales connected.
	GROSS/NET	Toggling between display of gross weight and net weight. Net weight can be displayed only if a tare weight has been entered. Note that a specific scale must be selected.
	PRINT	Printing of the displayed weight value on a connected printer according to parameter settings. Note that a specific scale must be selected.
	ZERO	Setting the gross weight value to zero (provided the value is in the zeroing range: -1 % to +3 % of the capacity) and setting the auto tare value to zero. Note that a specific scale must be selected.
	START	Starting batch activities.
	STOP	Stopping batch activities.

Digit keys

The digit keys, including keys with minus sign and decimal point, are used for entry and editing of numerical parameter values.

Miscellaneous keys

An ENTER key on the panel is used to open a selected menu, finish the entry of a value, etc.

The four arrow keys are used to navigate in the menu system and to toggle between selections.

The Esc, Alt, Del, Backspace and Tab keys are used for editing values, toggling between selections and so on.

The 'Info' key is used to enter the instrument menu system.

3. Set-up

General

All operating functions in the G4 Instrument are controlled by parameters. The parameter values are permanently stored in the instrument and will not be lost when the unit is switched off. At delivery the parameters are factory-set to default values, giving the instrument an initial standard function.

The actual setting of the parameter values can be read and edited during normal measuring operation in sub menu 'Parameter Set-up'.

Editing of parameter values can be performed using the color touch display and keys on the front panel of the instrument. After editing hardware parameters the instrument will be restarted.

In the instrument there are two levels of security locks provided to protect from unauthorized access to instrument functions and editing of parameters and values. The locks are opened by four-digit codes.

Warning: *Changes done during editing of set-up parameters will affect the behavior of the instrument immediately. The user must take all necessary precautions to prevent any undesired effects in the process monitored or controlled by the G4 instrument or a connected control system.*

It is strongly recommended to activate the set-up lock in the instrument to prevent any unauthorized changes of set-up parameters.

It's a good practice to make a backup of the set-up after changes have been done. See section '5. Operation – Main menu' for more information on backup and restore.

When the G4 Instrument is first taken into service, setting of a few parameters will quickly adapt the instrument to the transducers and give desired weighing function. The 'Quick Set-up' is described in a separate publication:

G4 Multi Channel Weighing Instrument Operating instructions, Quick installation PM/DT/HE Types

The 'Parameter Set-up' menu contain the following sub menus:

General: This parameter group controls the general functionality of the instrument. Such as display language, display mode, security, key functions and so on.

Hardware Configuration: Parameters used for configuring the instrument hardware. Note that when the instrument is starting up it will check that the installed hardware is compatible with the settings. If not an alarm will be issued.

Calibration: Parameters that affect the behavior of the eight possible weighing channels (scales) in the instrument. There are parameters for calibration type, calibration values, no of transducers, filter settings, motion detection, zero handling and so on. All weighing channels are individually settable.

Communication: Sub menus are Serial Com, Ethernet and Fieldbus. Serial Com sub menu content is parameters used to set-up COM1 (RS232) and COM2 (RS485) on the CPU module. Parameters are among others: com. port mode, baud

rate and data format. Ethernet sub menu content is parameters for Modbus TCP configuration. Fieldbus sub menu content is configuration parameters related to fieldbus communication such as address, baud rate and transmitted data setup.

Level Supervision: The instrument has 32 level supervisors that are configured from this sub menu. Settings for each level are which scale (measuring channel) that the individual level is to monitor, which signal that shall be monitored from the selected scale. Signals that can be monitored are gross weight, net weight, flow rate and so on. The output function e.g. if the output shall be active above or below the set level is configured here. The fourth parameter for each level is the hystereses setting.

Setpoints: The G4 instrument contains 16 setpoints that are individually configurable regarding which scale it shall be connected to and which signal it shall monitor.

Inputs: The use of the instruments digital inputs is set in this menu. Note that the inputs are numbered 11 to 68. Inputs 11 to 18 corresponds to inputs on slot 1 I/O module, 21 to 28 correspond to inputs on slot 2 I/O and so on. Note that the actual number of inputs depends on what type of I/O-module that is installed in the respective slots. A DIO8 module has 8 inputs a WF IN2 module has 4 inputs while an AOUT1 or AOUT4 has no inputs. Possible usage for an input is tare command, zero command, gross/net toggling and so on. Certain commands like taring is scale oriented and a second parameter for each input is used to set which scale it shall work with.

Outputs: The outputs menu contains the settings controlling the function of each output. Numbering is 11 to 68 for the I/O module outputs. See section 'Inputs' above on how individual output numbers correspond to each I/O slot. Each output can be assigned an output function: Level output status, setpoint output status, net mode, good zero, stable weight, flow rate displayed or In process status. All functions needs a second parameter that sets which level, setpoint or scale the output is supposed to work with.

Analog Outputs: This menu controls the behavior of an AOUT4 or an AOUT1 Analog output module. The output signal source (scale no and signal type) can be selected. Also output type and range high/low is settable.

Graphical touch display

To reach the main menu, press the 'Info' button on the instrument front panel.

Navigating in a menu is done with arrow keys or by tapping (touching) on the display on specific choices e.g. 'Parameter Set-up'.

To open a sub menu, e.g. Parameter Set-up, select the desired sub menu with arrow keys. The selected sub menu is highlighted. Then press 'Enter' to open the selected sub menu or just tap on the desired sub-menu to open it.

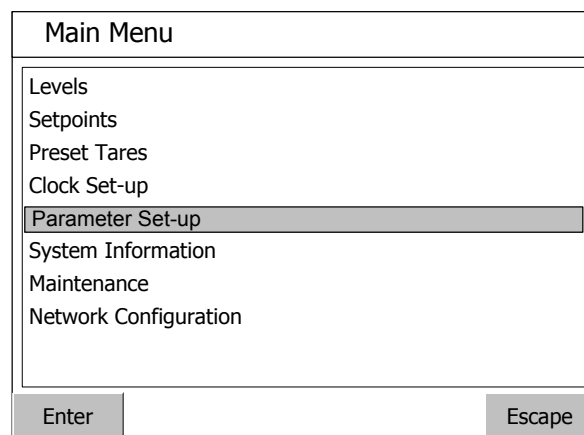

Main menu.

Parameter Set-up menu

To enter Parameter Set-up, select this sub menu with up/down arrow keys. The selected sub menu is then highlighted. Press 'Enter' to open the selected sub menu or just tap on the desired sub-menu to open it.

If there isn't room for all parameters on screen, it is possible to scroll through the list with the scroll bar at the right of the screen or by using up/down keys.

Press the 'Esc' key to return to the main menu. The 'Esc' key is always used to cancel editing or moving backwards in the menu structure.

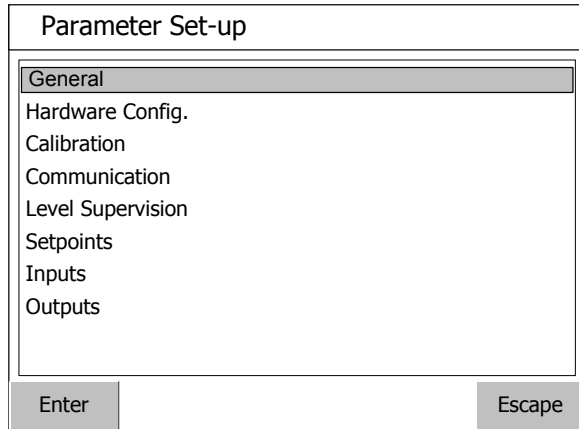

Parameter set-up menu.

Parameter editing

This example shows the 'General' parameter menu but editing is done similar throughout the menu system.

To edit a parameter, select it with the arrow keys to highlight it and then press the 'Enter' key on the screen or on the front panel keyboard. Alternatively tap on the desired parameter on the screen to begin editing.

If all items in the menu don't fit on the screen, it is possible to scroll through the list of parameters using the scroll bar at the right of the screen or by using the up/down keys.

Press the 'Esc' key to return to the Parameter set-up menu.

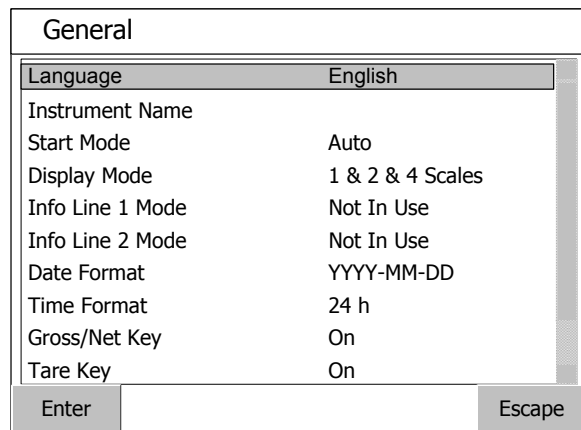

General parameters menu.

When editing a choice parameter e.g. language as in the figure, a list of available choices is shown on screen with the current selection highlighted. To change the selection the up/down arrow keys can be used. It is also possible to directly make a choice by tapping on the desired selection.

To confirm the new selection press the 'Enter' key.

To abort editing and keep the previous setting, press the 'Esc' key.

The screenshot shows a window titled "Edit: Language". Inside the window, there is a list of choices. "English" is highlighted with a grey background, and "Svenska" is listed below it. At the bottom of the window, there are two buttons: "Enter" on the left and "Escape" on the right.

Editing a choice parameter. Note that the languages mentioned are examples, not the actual implementation.

When editing a numerical parameter e.g. a level hystereses setting as in the figure, the new value should be typed with the numerical keys.

To confirm the new value press the 'Enter' key.

To abort editing and keep the previous setting, press the 'Esc' key.

The screenshot shows a window titled "Edit: Level 18 Hystereses". Inside the window, there is a text input field containing "23.200" followed by "kg". Below this, there are two lines of text: "Maximum value: 999999 kg" and "Minimum value: -999999 kg". At the bottom of the window, there are two buttons: "Enter" on the left and "Escape" on the right.

Editing a value parameter

Menu structure

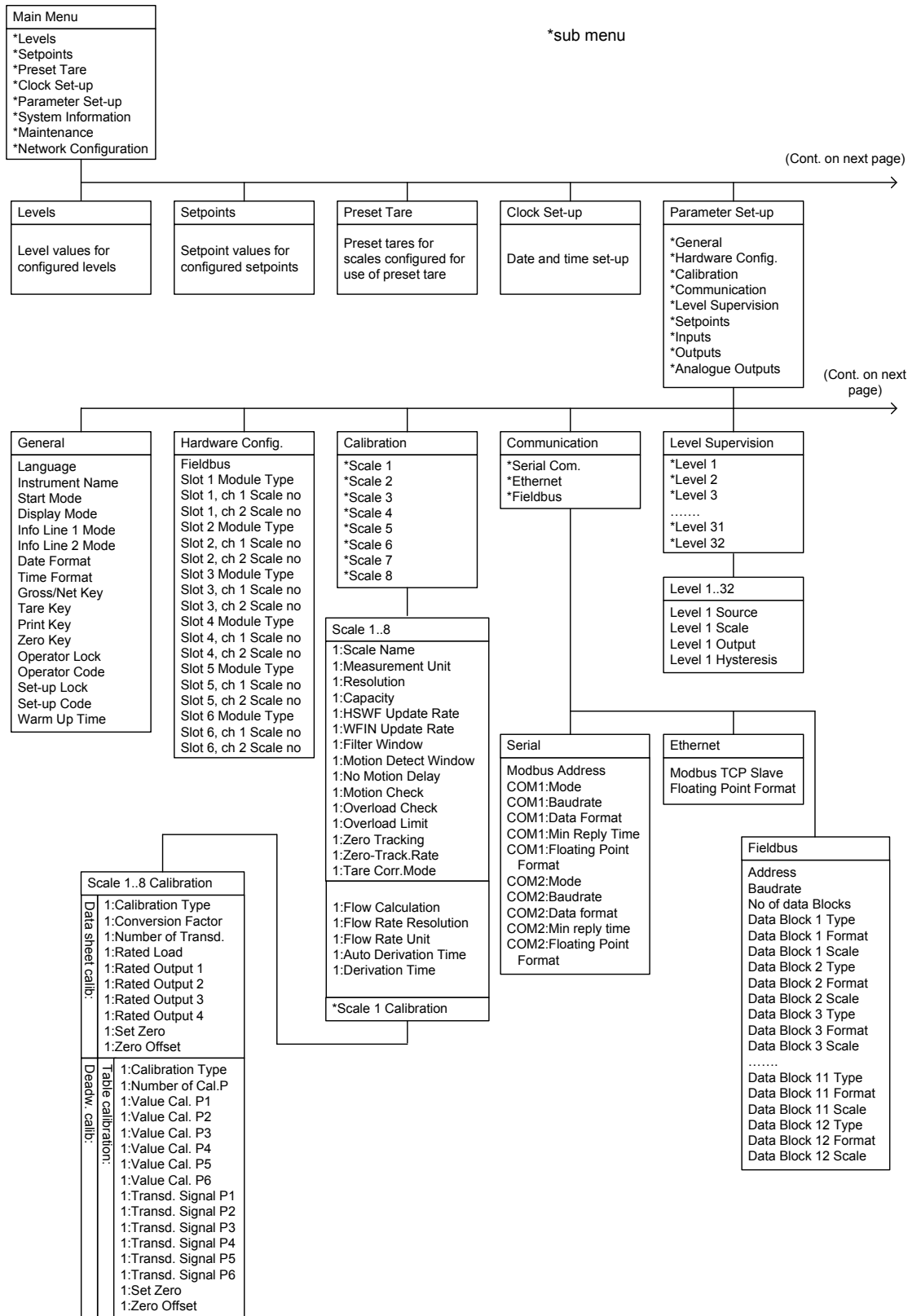

Menu structure (continued)

(from previous page)

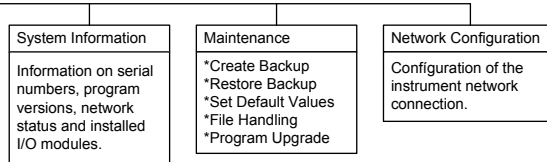

(from previous page)

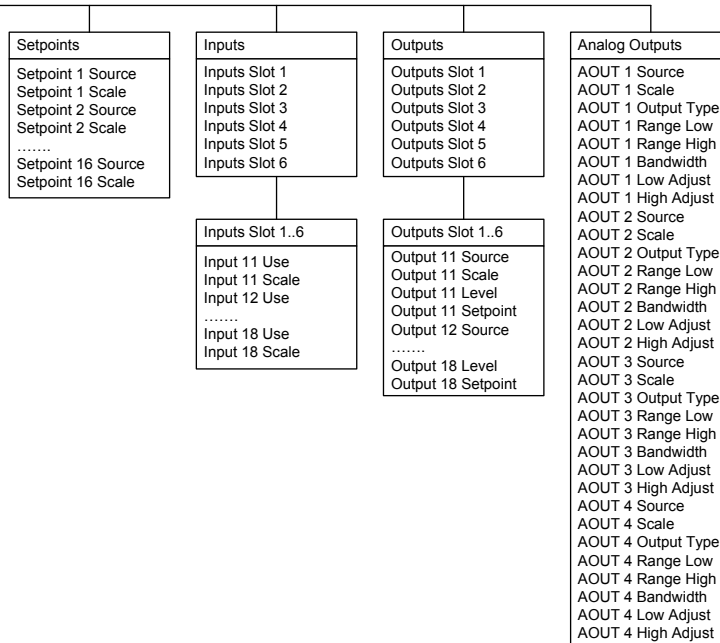

(Continued) Menu structure

Parameters

On the following pages a survey of all parameters is presented. The parameters are divided in groups following the menu they belong to. For choice parameters the available choices are given. For numerical parameters, a value range is given.

At the end of the table, the default value is given in < >.

To the right there is a short parameter explanation and, *in italic*, the results for the different alternatives.

Range/Alternatives <default value>	Explanation and result of alternatives.
---------------------------------------	--

Menu 'General'

Language

English	Defines the language to be used in menus and messages.
Svenska	
<English>	

Instrument Name

<>	A 16-character string that is used at printing in reports and so on.
----	--

Start Mode

Command	Defines the start mode after power-on or reset.
Auto	Command: A 'start operation' command from control computer or panel key is required for start up.
<Auto>	Auto: Automatic start up.

Range/Alternatives <default value>	Explanation and result of alternatives.
---------------------------------------	--

Display Mode

1 Scale	Defines the different operating mode screens that can be displayed on the graphical display.
2 Scales	
4 Scales	1 Scale: Only the 1 Scale display is shown. Operator can select which scale to display.
1 & 2 Scales	
1 & 4 Scales	2 Scales: Only the 2 Scales display is shown. Operator can select which scales (consecutive) to display.
2 & 4 Scales	
1 & 2 & 4 Scales	4 Scales: Only the 4 Scales display is shown. Operator can select which scales (consecutive) to display.
<1 & 2 & 4 Scales >	1 & 2 Scales: The operator can select between 1 and 2 Scales screens. Operator can select also which scale(s) to display. 1 & 4 Scales: The operator can select between 1 and 4 Scales screens. Operator can select also which scale(s) to display. 2 & 4 Scales: The operator can select between 2 and 4 Scales screens. Operator can select also which scale(s) to display. 1 & 2 & 4 Scales: The operator can select between all three different operating screen. Operator can select also which scale(s) to display.

Info Line 1 Mode

Not in use	Defines the mode of the first information line on the 1 scale screen on the graphical display.
Preset Tare	
Scale Name	Not in use: Info line 1 is not used.
< Not in use >	Preset Tare: The preset tare of the shown scale is presented on the first info. line Scale Name: The text entered in parameter Scale Name under Scale x Parameters menu of the shown scale is presented on the first info. line

Info Line 2 Mode

Not in use	Defines the mode of the second information line on the 1 scale screen on the graphical display.
Preset Tare	
Scale Name	See parameter 'Info Line 1 Mode' for details
< Not in use >	

Range/Alternatives <default value>	Explanation and result of alternatives.
Date Format	
YYYY-MM-DD	Defines the date format.
YYYY-DD-MM	YYYY: = year. MM: = month. DD: = day.
DD-MM-YYYY	
MM/DD/YYYY	
<YYYY-MM-DD>	
Time Format	
12 h	Defines the time format.
24 h	12 h: 12 hour time format.
	24 h: 24 hour time format.
<24h>	
Gross/Net key	
Off	Disables/enables front panel key Gross/Net
On	Off: The Gross/Net key is disabled.
<On>	On: The Gross/Net key is enabled
Tare key	
Off	Disables/enables front panel key Tare
On	Off: The Tare key is disabled.
<On>	On: The Tare key is enabled.
Print key	
Off	Disables/enables front panel key Print
On	Note that the print function is not implemented
<On>	in the current program version.
Zero key	
Off	Disables/enables front panel key Zero
On	Off: The Zero key is disabled.
<On>	On: The Zero key is enabled.

Range/Alternatives <default value>	Explanation and result of alternatives.
Operator Lock	
Off	Off: Operator lock is not activated.
On	On: Operator lock is activated, preventing unauthorized access to the instrument.
<Off>	See section '5. Operation – Security locks'.
Operator Code	
Range: 1 - 9999 <1937>	Defines the valid code for Operator lock. If 'Set-up lock' (see below) is 'On' this code will not give access to 'Parameter Set-up'. Note: this parameter is only shown if 'Operator Lock' is set to 'On'
Set-up Lock	
Off	Off: Set-up lock is not activated.
On	On: Set-up lock is activated, preventing unauthorized access to the instrument.
<Off>	See section '5. Operation – Security locks'.
Set-up Code	
Range: 1 - 9999 <1937>	Defines the valid code for Set-up lock. If 'Operator lock' (see above) is 'On' this code will still give access to all menus in the Main menu. Note: this parameter is only shown if 'Set-up Lock' is set to 'On'
Warm Up Time	
Range: 0 - 200 Unit: min <0>	Defines the delay time in minutes from power up until the weight presentation has full accuracy. Indicated in the display with the text 'Warming up!'.

Range/Alternatives <default value>	Explanation and result of alternatives.
---------------------------------------	--

Menu 'Hardware config.'

Fieldbus

Not In Use	This parameter defines what type of fieldbus that will be used in the CPU.
Profibus	
DeviceNet	
<Not In Use>	<p>Not In Use: The fieldbus is not used regardless of any installed module.</p> <p>Profibus: A Profibus type of fieldbus module is used.</p> <p>DeviceNet: A DeviceNet type of fieldbus module is used.</p>

Slot 1 Module Type

No module	This parameter defines what type of I/O-module that will be used in slot 1.
HSWF2	
WFIN	
WFIN2	
AOUT1	
AOUT4	
DIO8	
<WFIN2>	<p>No module: No module is used in this slot.</p> <p>HSWF2: A 2 channel high speed weight/force module.</p> <p>WFIN: A 1 channel, weight/force measuring module.</p> <p>WFIN2: A 2 channel, weight/force measuring module.</p> <p>AOUT1: A 1 channel analog output module.</p> <p>AOUT4: A 4 channel analog output module.</p> <p>DIO8: A 8/8 digital input/output module.</p>

Slot 1, ch 1 Scale no

Not in use	This parameter defines which scale (1 – 8) that channel 1 in slot 1 will be connected to. Each scale may only be assigned once.
1	
2	
3	
4	1: This slot and channel is assigned to scale no 1.
5	2: This slot and channel is assigned to scale no 2.
6
7	8: This slot and channel is assigned to scale no 8.
8	Not in use: This slot and channel is not assigned to any scale.
<1>	

Note: this parameter is only shown if 'Slot 1 Module type' is set to 'WFIN', 'WFIN2' or 'HSWF2'.

Slot 1, ch 2 Scale no

<2>	This parameter defines which scale (1 – 8) that channel 2 in slot 1 will be connected to. Each scale may only be assigned once.
	Note: this parameter is only shown if 'Slot 1 Module type' is set to 'WFIN2' or 'HSWF2'.

Range/Alternatives <default value>	Explanation and result of alternatives.
Slot 2 Module Type	
< No module >	This parameter defines what type of I/O- module is installed in slot 2. See 'Slot 1 Module type' for details on parameter values.
Slot 2, ch 1 Scale no	
<Not in use>	This parameter defines which scale (1 – 8) that channel 1 in slot 2 will be connected to. Each scale may only be assigned once. Note: this parameter is only shown if 'Slot 2 Module type' is set to 'WFIN', 'WFIN2' or 'HSWF2'.
Slot 2, ch 2 Scale no	
<Not in use>	This parameter defines which scale (1 – 8) that channel 2 in slot 2 will be connected to. Each scale may only be assigned once. Note: this parameter is only shown if 'Slot 2 Module type' is set to 'WFIN2' or 'HSWF2'.
Slot 3 Module Type	
< No module >	This parameter defines what type of I/O- module is installed in slot 3. See 'Slot 1 Module type' for details on parameter values.
Slot 3, ch 1 Scale no	
<Not in use>	This parameter defines which scale (1 – 8) that channel 1 in slot 3 will be connected to. Each scale may only be assigned once. Note: this parameter is only shown if 'Slot 3 Module type' is set to 'WFIN', 'WFIN2' or 'HSWF2'.
Slot 3, ch 2 Scale no	
<Not in use>	This parameter defines which scale (1 – 8) that channel 2 in slot 3 will be connected to. Each scale may only be assigned once. Note: this parameter is only shown if 'Slot 3 Module type' is set to 'WFIN2' or 'HSWF2'.
Slot 4 Module Type	
< No module >	This parameter defines what type of I/O- module is installed in slot 4. See 'Slot 1 Module type' for details on parameter values.
Slot 4, ch 1 Scale no	
<Not in use>	This parameter defines which scale (1 – 8) that channel 1 in slot 4 will be connected to. Each scale may only be assigned once. Note: this parameter is only shown if 'Slot 4 Module type' is set to 'WFIN', 'WFIN2' or 'HSWF2'.

Range/Alternatives <default value>	Explanation and result of alternatives.
Slot 4, ch 2 Scale no <Not in use>	This parameter defines which scale (1 – 8) that channel 2 in slot 4 will be connected to. Each scale may only be assigned once. Note: this parameter is only shown if 'Slot 4 Module type' is set to 'WFIN2' or 'HSWF2'
Slot 5 Module Type < No module >	This parameter defines what type of I/O- module is installed in slot 5. See 'Slot 1 Module type' for details on parameter values.
Slot 5, ch 1 Scale no <Not in use>	This parameter defines which scale (1 – 8) that channel 1 in slot 5 will be connected to. Each scale may only be assigned once. Note: this parameter is only shown if 'Slot 5 Module type' is set to 'WFIN', 'WFIN2' or 'HSWF2'.
Slot 5, ch 2 Scale no <Not in use>	This parameter defines which scale (1 – 8) that channel 2 in slot 5 will be connected to. Each scale may only be assigned once. Note: this parameter is only shown if 'Slot 5 Module type' is set to 'WFIN2' or 'HSWF2'.
Slot 6 Module Type < No module >	This parameter defines what type of I/O- module is installed in slot 6. See 'Slot 1 Module type' for details on parameter values.
Slot 6, ch 1 Scale no <Not in use>	This parameter defines which scale (1 – 8) that channel 1 in slot 6 will be connected to. Each scale may only be assigned once. Note: this parameter is only shown if 'Slot 6 Module type' is set to 'WFIN', 'WFIN2' or 'HSWF2'.
Slot 6, ch 2 Scale no <Not in use>	This parameter defines which scale (1 – 8) that channel 2 in slot 6 will be connected to. Each scale may only be assigned once. Note: this parameter is only shown if 'Slot 6 Module type' is set to 'WFIN2' or 'HSWF2'.

Range/Alternatives <default value>	Explanation and result of alternatives.
---------------------------------------	--

Menu 'Scale 1'

The Calibration menu contains up to 8 sub menus, one for each installed/used scale. The parameters are the same for all 8 scale menus. Here only scale 1 parameters are shown. Note that the scale number is shown as a prefix to the parameter name, here '1:.'

1:Scale Name

<>	A 16-character string that is used at printing in reports and so on.
----	--

1:Measurement Unit

NONE	Defines the engineering unit that should be used for the measured value and for related set-up parameters.
g	
kg	
t	
lb	
oz	
N	
daN	
kN	
psi	
kPa	
MPa	
bar	
lbf	
kgf	
Nm	
N/m	
kN/m	
PLI	
l	
mV/V	
pls	
<kg>	

1:Resolution

0.001	Defines the decimal point position and resolution format for the displayed value. All set-up parameters using the measurement unit will be written with the decimal point position selected in this menu. If the last digits of the weight value are not stable, a more coarse resolution can be selected to get a stable reading.
0.002	
0.005	
0.01	
0.02	
0.05	
0.1	
0.2	
0.5	
1	
2	
5	
10	
20	
50	
<0.1>	

Range/Alternatives <default value>	Explanation and result of alternatives.
---------------------------------------	--

1:Capacity

Range:	Nominal range of scale.
0.5 to 999999	Capacity / Resolution = Number of divisions.
Unit:	
Measurem. unit	
<500>	

1:HSWF Update Rate

12.5 Hz	Defines the update rate for the measuring channel belonging to scale 1 if the weight conversion module is of HS WF 2 type.
25 Hz	
50 Hz	
100 Hz	
200 Hz	
400 Hz	Note: this parameter is only shown if the weight conversion module belonging to scale 1 is of HS WF2 type.
800 Hz	
<50 Hz>	

1:WFIN Update Rate

2.3 Hz	Defines the update rate for the measuring channel belonging to scale 1 if the weight conversion module is of WF IN or WF IN2 type.
4.6 Hz	
9.3 Hz	
19 Hz	
37 Hz	
75 Hz	Note: this parameter is only shown if the weight conversion module belonging to scale 1 is of WF IN or WF IN2 type.
150 Hz	
300 Hz	
<37 Hz>	

1:Filter Window

Range:	The instrument produces unfiltered and filtered weight internally. If the difference between the filtered and unfiltered weight is less than 'Filter window' the filtered weight is used.
0 to 999999	
Unit:	
Measurem. unit	
<10 * Resolution>	This parameter value has one decimal more than parameter Resolution, to allow 'Filter window' to be smaller than the resolution.

1:Motion Detect Window

Range:	Motion status is 'on' when the weight value is not stable. It goes off when the weight has been stable for the 'No motion delay time'. Motion condition exists if the weight change during a certain measuring period is greater than the window 'Motion Detect Window'. The measuring period is one conversion time (Update Rate) or at least 200 ms. This parameter value has one decimal more than parameter Resolution, to allow 'Motion detect w.' to be smaller than the resolution.
0 to 999999	
Unit:	
Measurem. unit	
<1 * Resolution>	

Range/Alternatives <default value>	Explanation and result of alternatives.
1:No Motion Delay	
Range: 0 to 10.0 Unit: s <1.0>	Delay in seconds from detection of stable weight until the Motion status goes off.
1:Motion Check	
Off On <Off>	Off: Only zero adjustment is inhibited during motion. On: Inhibits zero adjustment, taring, and printing during motion.
1:Overload Check	
Off Unipolar Bipolar <Off>	Check of overload is performed according to this set-up. Off: No check is performed. Weight will be reported up to the limits of the AD converter. Unipolar: Overload status will be set if 'Overload limit' is exceeded. Underload status will be set if the gross weight is below minus (-) $9 * \text{Resolution}$. Bipolar: Overload status will be set if Overload limit is exceeded. Underload status will be set if the gross weight is below minus (-) Overload limit.
1:Overload Limit	
Range: 0.5 to 999999 Unit: Measrem. unit <Capacity + $9 * \text{Resolution}$ >	Should be set to the max gross weight that the weight indicator is allowed to report. This parameter is always set to default value when changing Resolution or Capacity. If 'Bipolar' overload check is selected the weight will be reported up to the Overload limit and down to the minus (-) Overload limit. Note: this parameter is only shown if parameter '1: Overload Check' is set to 'Unipolar' or 'Bipolar'.

Range/Alternatives <default value>	Explanation and result of alternatives.
---------------------------------------	--

1:Zero Tracking

Off	With this parameter automatic zero-tracking can be selected, or a combination of automatic zero-tracking and automatic zero setting.
On	
On+AutoZero	
<Off>	
	Off: No zero tracking.
	On: Zero tracking active.
	On+AutoZero: Zero tracking and auto zeroing active.

1:Zero-Track.Rate

Range: 0 to 1500	Maximum weight change speed for zero-tracking to be performed.
Unit: /min <1>	'Zero-track.rate' must be less than (30 * Resolution). Unit for the Zero-track rate is: Measurem. unit/min, expressed as '/min' to save space.

Note: this parameter is only shown if parameter '1: Zero tracking' is set to 'On' or 'On+AutoZero'.

1:Tare Corr.Mode

Auto	The tare value can be calculated in three different ways: Net weight = Gross weight – Tare value
Preset	
Auto+Preset	
<Auto>	
	Auto: Auto tare value is used.
	Preset: Tare value is entered through the serial communication or keypad.
	Auto+preset: Tare value is the sum of the preset tare value and auto tare value.

1:Flow Calculation

On	Used to turn on and off the flow rate calculations.
Off	
<Off>	
	On: Flow rate calculations are performed.
	Off: Flow rate calculations are not performed.

1:Flow Rate Resolution

0.001	Defines the decimal point position and resolution format for the flow rate value.
0.002	
0.005	All set-up parameters using the flow rate unit will be written with the decimal point position selected in this menu.
0.01	
0.02	If the last digits of the flow rate value are not stable, a more coarse resolution can be selected to get a stable reading.
0.05	
0.1	Note: this parameter is only shown if parameter '1:Flow calculation' is set to 'On'.
0.2	
0.5	
1	
2	
5	
10	
20	
50	
<0.02>	

Range/Alternatives <default value>	Explanation and result of alternatives.
1:Flow Rate Unit	
Unit/s Unit/min Unit/h Unit*1000/m Unit*1000/h <Unit/s>	<p>Defines the engineering unit that should be used for the flow rate value and for related set-up parameters.</p> <p>Unit/s: Measurement unit per second. Unit/min: Measurement unit per minute. Unit/h: Measurement unit per hour. Unit*1000/m: Measurement unit * 1000 per minute. Unit*1000/h: Measurement unit * 1000 per hour.</p> <p>If the flow rate unit exceeds 4 characters then it will be represented as "/s", "/min", "/h", "*/mi" or "*/h" in the set-up menus. In the case of "Unit*1000/m" or "Unit*1000/h" then some flow rate units will be preceded by a "k" and some will be converted, for example "kg" to "t".</p> <p>Note: this parameter is only shown if parameter '1:Flow calculation' is set to 'On'.</p>
1:Auto Derivation Time	
Off On <On>	<p>The derivation time can be entered manually or calculated automatically by the instrument.</p> <p>Off: Manual entering of derivation time. On: Automatic calculation of derivation time.</p> <p>Note: this parameter is only shown if parameter '1:Flow calculation' is set to 'On'.</p>
1:Derivation Time	
Range: 0.00 – 3600.00 Unit: s	<p>The flow rate is the weight change over the latest elapsed "Derivation time" divided by this time. At calibration the derivation time is always adjusted by the instrument to the nearest possible value (depending on the filter time).</p> <p>Note: this parameter is only shown if parameter '1:Flow calculation' is set to 'On'.</p> <p>Note: This parameter is read only if '1:Auto derivation time' is set to 'On'.</p>

Range/Alternatives <default value>	Explanation and result of alternatives.
---------------------------------------	--

Menu 'Scale 1 Calibration'

The Scale 1 Calibration menu is found after the last parameter in menu Scale. Here only scale 1 menu is shown. Note that the scale number is shown as a prefix to the parameter name, here '1:'

1:Calibration Type

Data Sheet	Defines the type of calibration to be performed.
Deadweight Table	A new calibration is initiated as a 'Calibration type' is selected.
<Data Sheet>	<p>Data Sheet: <i>Data sheet calibration is easy to use and doesn't demand any reference equipment, except data from the transducer data sheets.</i></p> <p>Deadweight: <i>Deadweight calibration is normally the most accurate calibration type. It requires known weights to at least 2/3 of the wanted measuring range.</i></p> <p>Table: <i>Table calibration is used to enter recorded values from a previous calibration into a replacement instrument.</i></p>

Data sheet calibration related parameters

1:Conversion Factor

Range: 0.01 to 100 <9.80665>	Defines the relationship between a measured value expressed in data sheet unit and expressed in the selected measurement unit.
------------------------------------	--

1:Number of Transducers

Range: 1 to 4 <3>	<p>Defines the number of transducers and fixed support points in the scale installation. All transducers must have equal rated load.</p> <p>If the total number is over 4: enter 1 here!</p>
-------------------------	--

1:Rated Load

Range: 1 to 999999	Defines the rated load for one transducer, expressed in the data sheet unit. The value is specified in the transducer data sheet.
Unit: Data sheet unit <2000.00>	<p>NOTE! If the data sheet value is 5 kN, the parameter should be set to 5000 (N).</p> <p>If the total number of transducers and fixed supports is over 4: multiply that number with the rated load for one transducer and enter the result here!</p>

Range/Alternatives <default value>	Explanation and result of alternatives.
1:Rated Output 1	
Range: 0 to 9.99999 Unit: mV/V <2.03900>	Defines the rated output signal for transducer 1. The value is specified in the transducer data sheet for transducer 1. If the total number of transducers and fixed supports is over 4: add up all rated output values, divide by the <u>number of transducers</u> , and enter the result here!
1:Rated Output 2	
Range: 0 to 9.99999 Unit: mV/V <2.03900>	Defines the rated output signal for transducer 2. The value is specified in the transducer data sheet for transducer 2.
1:Rated Output 3	
Range: 0 to 9.99999 Unit: mV/V <2.03900>	Defines the rated output signal for transducer 3. The value is specified in the transducer data sheet for transducer 3.
1:Rated Output 4	
Range: 0 to 9.99999 Unit: mV/V <2.03900>	Defines the rated output signal for transducer 4. The value is specified in the transducer data sheet for transducer 4.
1:Set Zero	
Range: +/-999999 Unit: Measur. unit <'Live'>	Live weight is displayed at the bottom of the screen. Enter wanted value for the actual load, usually '0', i.e. unloaded scale. NOTE! This parameter should be used for zeroing of the instrument.
1:Zero Offset	
Range: +/-999999 Unit: Measur. unit <0>	This menu shows the offset value acquired by zeroing in 'Set zero'. If this parameter is edited, the zeroing will be influenced.

Range/Alternatives <default value>	Explanation and result of alternatives.
---------------------------------------	--

Deadweight calibration related parameters

Used when the scale is calibrated with weights. The instrument automatically reads the corresponding transducer signals.

1:No of Calibration Points

Range: 2 to 6
<2>

Number of calibration points.

1:Value Cal. P1

Range: +/-999999
Unit:
Measurem. unit
<0>

This parameter defines the load on the scale in the lowest calibration point, normally 0.

1:Value Cal. P2

Range: +/-999999
Unit:
Measurem. unit
<500>

This parameter defines the load on the scale in the second calibration point.

1:Value Cal. P3

Range: +/-999999
Unit:
Measurem. unit
<0>

This parameter defines the load on the scale in the third calibration point.

1:Value Cal. P4

Range: +/-999999
Unit:
Measurem. unit
<0>

This parameter defines the load on the scale in the fourth calibration point.

1:Value Cal. P5

Range: +/-999999
Unit:
Measurem. unit
<0>

This parameter defines the load on the scale in the fifth calibration point.

1:Value Cal. P6

Range: +/-999999
Unit:
Measurem. unit
<0>

This parameter defines the load on the scale in the sixth calibration point.

Range/Alternatives <default value>	Explanation and result of alternatives.
1:Transd. Signal P1	
Range: +/-9.99999 Unit: mV/V <0.00000>	In this parameter, the transducer signal in the lowest calibration point is displayed, but the value cannot be edited.
1:Transd. Signal P2	
Range: +/-9.99999 Unit: mV/V <1.66631>	In this parameter, the transducer signal in the second calibration point is displayed, but the value cannot be edited.
1:Transd. Signal P3	
Range: +/-9.99999 Unit: mV/V <2.03900>	In this parameter, the transducer signal in the third calibration point is displayed, but the value cannot be edited.
1:Transd. Signal P4	
Range: +/-9.99999 Unit: mV/V <2.03900>	In this parameter, the transducer signal in the fourth calibration point is displayed, but the value cannot be edited.
1:Transd. Signal P5	
Range: +/-9.99999 Unit: mV/V <2.03900>	In this parameter, the transducer signal in the fifth calibration point is displayed, but the value cannot be edited.
1:Transd. Signal P6	
Range: +/-9.99999 Unit: mV/V <2.03900>	In this parameter, the transducer signal in the sixth calibration point is displayed, but the value cannot be edited.
1:Set Zero	
	See '1:Set zero ' under section 'Data sheet calibration related parameters' for explanation of the parameter.
1:Zero Offset	
	See '1:Zero offset ' under section 'Data sheet calibration related parameters' for explanation of the parameter.

Range/Alternatives <default value>	Explanation and result of alternatives.
---------------------------------------	--

Table calibration related parameters

Used when the scale is calibrated with recorded values from a previous calibration, normally a deadweight calibration.

1:No of Calibration Points

Range: 2 to 6
Unit: Number of calibration points.
Measurement unit: <2>

1:Value Cal. P1

Range: +/-999999
Unit: In this parameter, enter the recorded value for the load in the first calibration point.
Measurement unit: <0>

1:Value Cal. P2

Range: +/-999999
Unit: In this parameter, enter the recorded value for the load in the second calibration point.
Measurement unit: <500>

1:Value Cal. P3

Range: +/-999999
Unit: In this parameter, enter the recorded value for the load in the third calibration point.
Measurement unit: <0>

1:Value Cal. P4

Range: +/-999999
Unit: In this parameter, enter the recorded value for the load in the fourth calibration point.
Measurement unit: <0>

1:Value Cal. P5

Range: +/-999999
Unit: In this parameter, enter the recorded value for the load in the fifth calibration point.
Measurement unit: <0>

1:Value Cal. P6

Range: +/-999999
Unit: In this parameter, enter the recorded value for the load in the sixth calibration point.
Measurement unit: <0>

Range/Alternatives <default value>	Explanation and result of alternatives.
1:Transd. Signal P1	
Range: +/-9.99999 Unit: mV/V <0.00000>	In this parameter, enter the recorded value for the transducer signal in the first calibration point.
1:Transd. Signal P2	
Range: +/-9.99999 Unit: mV/V <1.66631>	In this parameter, enter the recorded value for the transducer signal in the second calibration point.
1:Transd. Signal P3	
Range: +/-9.99999 Unit: mV/V <2.03900>	In this parameter, enter the recorded value for the transducer signal in the third calibration point.
1:Transd. Signal P4	
Range: +/-9.99999 Unit: mV/V <2.03900>	In this parameter, enter the recorded value for the transducer signal in the fourth calibration point.
1:Transd. Signal P5	
Range: +/-9.99999 Unit: mV/V <2.03900>	In this parameter, enter the recorded value for the transducer signal in the fifth calibration point.
1:Transd. Signal P6	
Range: +/-9.99999 Unit: mV/V <2.03900>	In this parameter, enter the recorded value for the transducer signal in the sixth calibration point.
1:Set Zero	
	See '1:Set zero ' under section 'Data sheet calibration related parameters' for explanation of the parameter.
1:Zero Offset	
	See '1:Zero offset ' under section 'Data sheet calibration related parameters' for explanation of the parameter.

Range/Alternatives <default value>	Explanation and result of alternatives.
---------------------------------------	--

Menu 'Serial Com'

Modbus Address

Range: 1 to 247
<1> Defines the instrument Modbus address.

COM1:Mode

Not in use
Modbus Slave
<Not in use>

Defines use of serial port Com 1.
Not in use: *The port is not used.*
Modbus Slave: *The port is used for control unit communication.*

COM1:Baudrate

300
600
1200
2400
4800
9600
19200
38400
57600
115200
<9600>

Defines the baudrate for the serial communication.
The parameter must be set to the baudrate of the external equipment.
Note: This parameter is not shown if 'Not in use' is selected in 'COM1:Mode'.

COM1:Data Format

7-none-2
7-even-1
7-even-2
7-odd-1
7-odd-2
8-none-1
8-none-2
8-even-1
8-odd-1
< 8-none-1 >

Defines the bit configuration for the serial communication.
The parameter must be set to the same configuration as for the external equipment.
Note: This parameter is not shown if 'Not in use' is selected in 'COM1:Mode'.

COM1:Min Reply Time

Range: 0 to 1000
Unit: ms
<0>

Adds a delay before the response to a command is sent.
Used if the instrument sends its response too fast for the master.

Note: This parameter is not shown if 'Not in use' is selected in 'COM1:Mode'.

Range/Alternatives <default value>	Explanation and result of alternatives.
---------------------------------------	--

COM1:Floating Point Format

Modicon Float Float < Modicon Float >	Sets how the Modbus slave should handle floating point values. Modicon Float: <i>Modicon floating point format.</i> Float: <i>IEEE 32 bit floating point format</i>
	See chapter 6 Communication for details on floating point values.
	Note: This parameter is not shown if 'Not in use' is selected in 'COM1:Mode'.

COM2:Mode

Not in use Modbus Slave <Not in use>	Defines the use for serial port Com 2. Not in use: <i>The serial port is not used.</i> Modbus Slave: <i>The serial port is used for communication with a control unit.</i>
--	--

COM2:Baudrate

300 600 1200 2400 4800 9600 19200 38400 57600 115200 <115200>	Defines the baudrate for the serial communication. The parameter must be set to the baudrate of the external equipment. Note: This parameter is not shown if 'Not in use' is selected in 'COM2:Mode'.
---	---

COM2:Data Format

7-none-2 7-even-1 7-even-2 7-odd-1 7-odd-2 8-none-1 8-none-2 8-even-1 8-odd-1 < 8-none-1 >	Defines the bit configuration for the serial communication. The parameter must be set to the same configuration as for the external equipment. Note: This parameter is not shown if 'Not in use' is selected in 'COM2:Mode'.
---	--

COM2:Min Reply Time

Range: 0 to 1000 Unit: ms <0>	Adds a delay before the response to a Modbus command is sent. Used if the instrument sends its response to fast for the Modbus master. Note: This parameter is not shown if 'Not in use' is selected in 'COM2:Mode'.
-------------------------------------	---

Range/Alternatives <default value>	Explanation and result of alternatives.
---------------------------------------	--

COM2:Floating Point Format

Modicon Float Float < Modicon Float >	Sets how the Modbus Slave should handle floating point values. Modicon Float: <i>Modicon floating point format.</i> Float: <i>IEEE 32 bit floating point format.</i> See chapter 6 Communication for details on floating point values. Note: This parameter is not shown if 'Not in use' is selected in 'COM2:Mode'.
---	--

Menu 'Ethernet'

Modbus TCP Slave

On Off <Off>	Enables/disables the Modbus TCP Slave. On: <i>Modbus TCP Slave enabled.</i> Off: <i>Modbus TCP Slave disabled.</i>
--------------------	--

Floating Point Format

Modicon Float Float < Modicon Float >	Sets how the Modbus TCP Slave should handle floating point values. Modicon Float: <i>Modicon floating point format.</i> Float: <i>IEEE 32 bit floating point format.</i> See chapter 6 Communication for details on floating point values. Note: This parameter is not shown if parameter 'Modbus TCP Slave' is set to 'Off'.
---	---

Range/Alternatives <default value>	Explanation and result of alternatives.
---------------------------------------	--

Menu 'Fieldbus'

Note: The Fieldbus menu is not shown if parameter 'Fieldbus' (in Hardware Config menu) is set to 'Not In Use'. See chapter 6 'Communication – Fieldbus interface' for more details on fieldbus configuration and usage.

Address

Range 1 - 125 Profibus address setting.

< 126 >

Note: This parameter is only shown if parameter 'Fieldbus' (in Hardware Config menu) is set to 'Profibus'.

Address

Range 0 - 63 DeviceNet address setting

< 63 >

Note: This parameter is only shown if parameter 'Fieldbus' (in Hardware Config menu) is set to 'DeviceNet'.

Baudrate

125 kbps

250 kbps

500 kbps

Auto

< Auto >

Sets the baudrate for a DeviceNet type of module. Must be selected to suite the master.

125 kbps: Fixed baudrate 125 kbits/s.

250 kbps: Fixed baudrate 250 kbits/s.

500 kbps: Fixed baudrate 500 kbits/s.

Auto: Auto setting 125 – 500 kbits/s.

Note: This parameter is only shown if parameter 'Fieldbus' (in Hardware Config menu) is set to 'DeviceNet'.

No of Data Blocks

Range 0 - 12

< 0 >

Sets the no of Data Blocks that should be mapped to the memory available from the fieldbus. Each Data Block is configurable.

Range/Alternatives <default value>	Explanation and result of alternatives.
---------------------------------------	--

Data Block 1 Type

Not In Use	Sets the data source for Data Block 1.
Gross Weight	Not In Use: The memory area corresponding to this data block is not updated.
Net Weight	Gross Weight: The gross weight for the selected scale is transmitted in this Data Block. Floating point or Integer format.
Disp. Weight	Net Weight: The net weight for the selected scale is transmitted in this Data Block. Floating point or Integer format.
Flow Rate	Disp. Weight: The displayed weight (gross or net) for the selected scale is transmitted in this Data Block. Floating point or Integer format.
Input Signal	Flow Rate: The Flow Rate for the selected scale is transmitted in this Data Block. Floating point or Integer format.
Level Status	Input Signal: The input signal from the transducer (the mV/V signal) for the selected scale is transmitted in this Data Block. Floating point or Integer format.
Setpoint Status	Level Status: The status of all 32 levels in the instrument is transmitted in this Data Block. Floating-point format.
Input Status	Setpoint Status: The status of all 16 setpoints in the instrument is transmitted in this Data Block. Floating-point format.
Output Status	Input Status: The status of all inputs in the instrument is transmitted in this Data Block. Floating-point format.
Inp./Outp Status	Output Status: The status of all outputs in the instrument is transmitted in this Data Block. Floating-point format.
Lev./Setp Status	Inp./Outp Status: The status of all inputs and all outputs in the instrument is transmitted in this Data Block. Integer format.
AOUT1-4 Value	Lev./Setp Status: The status of all 32 levels and the status of all 16 setpoints in the instrument are transmitted in this Data Block. Integer format.
AOUT1-2 Value	AOUT1-4 Value: The values of analog outputs 1 to 4 are transmitted in this Data Block. Floating-point format.
AOUT3-4 Value	AOUT1-2 Value: The values of analog outputs 1 and 2 are transmitted in this Data Block. Integer format.
< Not In Use >	AOUT3-4 Value: The values of analog outputs 3 and 4 are transmitted in this Data Block. Integer format.

Note: This parameter is only shown if parameter 'No Of Data Blocks' is set to 1 or greater.

Data Block 1 Format

Floating Point	Sets the Data Block 1 Format.
Integer	Floating Point: The Data Block data format is floating point.
< Floating Point >	Integer: The Data Block format is integer.

Note: This parameter is only shown if parameter 'No Of Data Blocks' is set to 1 or greater and parameter 'Data Block 1 Type' is set to 'Gross Weight', 'Net Weight', 'Disp. Weight', 'Flow Rate' or 'Input Signal'.

Range/Alternatives <default value>	Explanation and result of alternatives.
---------------------------------------	--

Data Block 1 Scale

1	Selects the source scale for Data Block 1.
2	<i>1: The Data Block uses data from scale no 1.</i>
3	<i>2: The Data Block uses data from scale no 2.</i>
4
5
6	<i>8: The Data Block uses data from scale no 8.</i>
7	Note: This parameter is only shown if parameter
8	'No Of Data Blocks' is set to 1 or greater and parameter 'Data
< 1 >	Block 1 Type' is set to 'Gross Weight', 'Net Weight', 'Disp. Weight', 'Flow Rate' or 'Input Signal'.

Data Block 2 Type

Sets the data source for Data Block 2.

Note: This parameter is only shown if parameter 'No Of Data Blocks' is set to 2 or greater.

See 'Data Block 1 Type' for an explanation of the parameter.

Data Block 2 Format

Sets the Data Block 2 Format.

Note: This parameter is only shown if parameter 'No Of Data Blocks' is set to 2 or greater.

See 'Data Block 1 Format' for an explanation of the parameter.

Data Block 2 Scale

Selects the source scale for Data Block 2.

Note: This parameter is only shown if parameter 'No Of Data Blocks' is set to 2 or greater.

See 'Data Block 1 Scale' for an explanation of the parameter.

For explanation on parameters for Data Blocks 3 to 12 see 'Data Block 1 Type', 'Data Block 1 Format' and 'Data Block 1 Scale'. Note that the parameters are shown only if 'No Of Data Blocks' is set equal to or greater than the Data Block number.

Range/Alternatives <default value>	Explanation and result of alternatives.
---------------------------------------	--

Menus 'Level 1' – 'Level 32'

NOTE: There are 32 levels each with the following four parameters described below.

Level 1 Source (- Level 32 Source)

Not in use	Defines the signal to be supervised by the level.
Net Weight	Not in use: <i>The level is not used, any outputs set to work with this level will be off.</i>
Gross Weight	Net weight: <i>The level operates on the net weight.</i>
Display Weight	Gross weight: <i>The level operates on the gross weight</i>
Flow Rate	Display weight: <i>The level operates on gross weight or net weight, even if the flow rate is displayed.</i>
Abs. Net Weight	Flow rate: <i>The level operates on the flow rate.</i>
Abs.Gross Weight	Abs.: <i>Stands for Absolute,</i>
Abs.Disp. Weight	<i>the level operates on the absolute value of net weight,</i>
Abs. Flow Rate	<i>gross weight, displayed weight, or flow rate.</i>
< Not in use >	

Level 1 Scale (- Level 32 Scale)

1	Defines which scale that will be supervised by the level.
2	1: <i>The level is supervising scale number 1.</i>
3	2: <i>The level is supervising scale number 2.</i>
4	
5
6	8: <i>The level is supervising scale number 8.</i>
7	
8	Note: This parameter is only shown if 'Level 1 Source' is
<1>	not set to 'Not in use'.

Level 1 Output (- Level 32 Output)

Active Above	This parameter defines the conditions for control of a possible used output.
Active Below	
< Active above >	Active above: <i>The used output is activated as the supervised signal level is above the set level.</i> Active below: <i>The used output is activated as the supervised signal level is below the set level.</i>
	Note: This parameter is only shown if 'Level 1 Source' is not set to 'Not in use'.

Level 1 Hystereses (- Level 32 Hystereses)

Range:	Defines the hystereses range for the level.
+/-999999	Positive value gives a hystereses range above the switch level, negative value gives a range below the switch level.
Unit:	
Measurem. unit or flow unit.	
< 0.2 >	Note: This parameter is only shown if 'Level 1 Source' is not set to 'Not in use'.

Range/Alternatives <default value>	Explanation and result of alternatives.
---------------------------------------	--

Menu 'Setpoints'

NOTE: There are 16 setpoints each with the following two parameters described below.

Setpoint 1 Source (- Setpoint 16 Source)

Not in use	Defines the signal to be supervised by the setpoint.
Net Weight	Not in use: The setpoint is not used, any outputs set to work with this setpoint will be off.
Gross Weight	Net Weight: The Setpoint operates on the net weight.
Display Weight	Gross Weight: The Setpoint operates on the gross weight
Flow Rate	Display Weight: The Setpoint operates on gross weight or net weight, even if the flow rate is displayed.
Abs. Net Weight	Flow Rate: The Setpoint operates on the flow rate.
Abs.Gross Weight	Abs.: Stands for Absolute, the Setpoint operates on the absolute value of net weight, gross weight, displayed weight, or flow rate.
Abs.Disp. Weight	
Abs. Flow Rate	
< Not in use >	

Setpoint 1 Scale (- Setpoint 16 Scale)

1	1: The setpoint is supervising scale number 1.
2	2: The setpoint is supervising scale number 2.
3
4	
5	8: The setpoint is supervising scale number 8.
6	
7	Note: This parameter is only shown if 'Setpoint 1 Source' is not set to 'Not in use'.
8	
<1>	

Range/Alternatives <default value>	Explanation and result of alternatives.
---------------------------------------	--

Menus 'Inputs Slot 1' - 'Inputs Slot 6'

NOTE: There are six possible sub menus, one for each slot. In each slot sub menu there are up to 8 possible inputs named 11 to 18 for slot 1, 21 to 28 for slot 2 and so on. Each input has the parameters described below. Note that input numbering below only show inputs belonging to slot 1. The 'Inputs Slot X' is only shown if there is a module with inputs selected for slot X. The number of displayed inputs is the number of inputs of the specific module selected in menu 'Hardware Configuration'.

Input 11 Use (- Input 18 Use)

Not in use	Defines the use of the internal digital inputs in the instrument.
Tare	Not in use: <i>The input is not used.</i>
Gross/Net	Tare: <i>Input used for taring command.</i>
Gross	Gross/Net: <i>Input used for gross/net toggling.</i>
Net	Gross: <i>Input used to switch to gross mode.</i>
Zero	Net: <i>Input used to switch to net mode.</i>
Flow/Weight	Zero: <i>Input used for zero command.</i>
Flow Rate	Flow/Weight: <i>Input used for flow rate/weight toggling.</i>
Weight	Flow Rate: <i>Input used to switch to flow rate mode.</i>
< Not in use >	Weight: <i>Input used to switch to weight mode.</i>

Input 11 Scale (- Input 18 Scale)

1	1: <i>Scale number 1 uses the input.</i>
2	2: <i>Scale number 2 uses the input.</i>
3
4
5	8: <i>Scale number 8 uses the input.</i>
6	Note: this parameter is not shown if parameter
7	'Input 11 Source' is 'Not in use'.
8	
<1>	

Range/Alternatives <default value>	Explanation and result of alternatives.
---------------------------------------	--

Menus 'Outputs slot 1' - 'Outputs slot 6'

NOTE: There are six possible sub menus, one for each slot. In each slot sub menu there are up to 8 possible outputs named 11 to 18 for slot 1, 21 to 28 for slot 2 and so on. Each output has the parameters described below. Note that output numbering below only show outputs belonging to slot 1. The 'Outputs Slot X' is only shown if there is a module, with outputs, selected for slot X. The number of displayed outputs is the number of outputs of the specific module selected in menu 'Hardware Configuration'.

Output 11 Source (- Output 18 Source)

Not in use	Defines the use of the internal digital outputs
In Process	in the instrument.
Level	Not in use: The output is not used.
Setpoint	In Process: Active output means active 'In process'.
Net Mode	Level: Output activated by the Level.
Good Zero	Setpoint: Output activated by the Setpoint.
Stable Weight	Net Mode: Output active in net mode.
Flow R.Disp	Good Zero: Output active by 'good zero'.
< Not in use >	Stable Weight: Output active by stable weight.
	Flow R.Disp: Output active by flow rate display.

Output 11 Scale (- Output 18 Scale)

1	1: Scale number 1 uses the output.
2	2: Scale number 2 uses the output.
3
4
5	8: Scale number 8 uses the output.
6	Note: this parameter is only shown if parameter
7	'Output 11 Source' is 'Net mode', 'Good zero', 'Stable Weight'
8	or 'Flow r. disp'
<1>	

Output 11 Level (- Output 18 Level)

1	1: Level number 1 uses the output.
2	2: Level number 2 uses the output.
3	3: Level number 3 uses the output.
....
30	30: Level number 30 uses the output.
31	31: Level number 31 uses the output.
32	32: Level number 32 uses the output.
<1>	Note: this parameter is only shown if parameter
	'Output 11 Source' is 'Level'.

Range/Alternatives <default value>	Explanation and result of alternatives.
---------------------------------------	--

Output 11 Setpoint (- Output 18 Setpoint)

1	1: Setpoint number 1 uses the output.
2	2: Setpoint number 2 uses the output.
3	3: Setpoint number 3 uses the output.
....
14	14: Setpoint number 14 uses the output.
15	15: Setpoint number 15 uses the output.
16	16: Setpoint number 16 uses the output.
< 1 >	Note: this parameter is only shown if parameter 'Output 11 Source' is 'Setpoint'.

Range/Alternatives <default value>	Explanation and result of alternatives.
---------------------------------------	--

Menu 'Analog Outputs'

NOTE: There are 4 possible analog outputs each with the 8 parameters described below. If the selected analog output module is AOUT4 there will be parameters for four analog outputs displayed, if the AOUT1 is selected only the parameters for the first analog output (shown below) will be shown. If no AOUT module at all is selected the menu 'Analog Outputs' will not be shown.

AOUT 1 Source (- AOUT 4 Source)

Not in use	Defines the value to represent on analog output 1.
Gross Weight	Not in use: <i>The analog output is not used.</i>
Net Weight	Gross Weight: <i>The output represents gross weight.</i>
Disp. Weight	Net Weight: <i>The output represents net weight.</i>
Flow Rate	Disp. Weight: <i>The output represents gross or net weight, even if flow rate is displayed.</i>
< Not in use >	Flow Rate: <i>The output represents flow rate.</i>

AOUT 1 Scale (- AOUT 4 Scale)

1	1: <i>Scale number 1 uses this analog output.</i>
2	2: <i>Scale number 2 uses this analog output.</i>
3
4
5	8: <i>Scale number 8 uses this analog output.</i>
6	Note: this parameter is not shown if parameter
7	'AOUT 1 Source' is 'Not in use'.
8	
< 1 >	

AOUT 1 Output Type (- AOUT 4 Output Type)

+/- 20 mA	Defines the type of signal, used to represent
-12 – 20 mA	the weight/flow rate value at this Analog output.
0-20 mA	+/-20mA, -12 - 20mA: <i>bipolar current output.</i>
4-20 mA	0-20mA, 4-20mA: <i>monopolar current output.</i>
+/-10 V	+/-10V: <i>bipolar voltage output.</i>
0-10 V	0-10V: <i>monopolar voltage output.</i>
<4-20 mA>	Note: this parameter is not shown if parameter
	'AOUT 1 Source' is 'Not in use'.
	Note that in most cases some over range is available.
	+/-20 mA and -12 – 20 mA ranges are limited
	at -22 and +22 mA.
	4 -20 mA range is limited at +4 and +22 mA.
	0 -20 mA is limited at 0 and +22 mA.
	+/-10 V is limited at -11 and +11V.
	0-10 V is limited at 0 and +11V.

Range/Alternatives <default value>	Explanation and result of alternatives.
---------------------------------------	--

AOUT 1 Range Low (- AOUT 4 Range Low)

Range: +/-999999	Defines the weight/flow rate value that should give the lowest output (0 V / 0 mA / 4 mA) at this Analog output.
Unit:	Analog output.
Measurem. unit or flow unit <0>	Note: this parameter is not shown if parameter 'AOUT 1 Source' is 'Not in use'.

AOUT 1 Range High (- AOUT 4 Range High)

Range: +/-999999	Defines the weight/flow rate value that should give the highest output (10 V / 20 mA) at this Analog output.
Unit:	Analog output.
Measurem. unit or flow unit <500>	Note: this parameter is not shown if parameter 'AOUT 1 Source' is 'Not in use'.

AOUT 1 Bandwidth (- AOUT 4 Bandwidth)

1.6 Hz	Sets the analog output bandwidth.
3 Hz	Note: this parameter is not shown if parameter 'AOUT 1 Source' is 'Not in use'.
6 Hz	
12 Hz	
25 Hz	
50 Hz	
100 Hz	
<100 Hz>	

AOUT 1 Low Adjust (- AOUT 4 Low Adjust)

Range: +/-2.000	Gives a possibility to adjust the offset of the analog output. This allows for the reading of an external instrument connected to the analog output to be fine-tuned. Full adjustment range corresponds to approximately +/-2% of maximum analog output.
Unit: %	
<0.000>	The parameter value will be set to zero each time 'AOUT 1 Output Type' is changed.
	Note: this parameter is not shown if parameter 'AOUT 1 Source' is 'Not in use'.

AOUT 1 High Adjust (- AOUT 4 High Adjust)

Range: +/-2.000	Gives a possibility to adjust the gain of the analog output signal. This allows for the reading of an external instrument connected to the analog output to be fine-tuned. Full adjustment range corresponds to approximately +/-2% of maximum analog output.
Unit: %	
<0.000>	The parameter value will be set to zero each time 'AOUT 1 Output Type' is changed.
	Note: this parameter is not shown if parameter 'AOUT 1 Source' is 'Not in use'.

4. Calibration

General

When measuring with G4 Instrument, the transducer output signal, corresponding to the transducer load, is converted to a weight value. The conversion is controlled by several parameters with values defined during calibration of the instrument.

Some calibration types for the instrument can be performed without any transducers connected.

The G4 Instrument supports three calibration types:

- **Data sheet calibration** - entry of values from transducer data sheet(s).
- **Table calibration** - entry of recorded values from a previous calibration.
- **Deadweight calibration** - storing of measured transducer signals for known weights.

Calibration can only be performed in menu:

'Parameter set-up/Calibration/Scale n.'

A 'Set-up code' may be demanded. Note that the weighing result for the calibrated scale may be temporarily incorrect during calibration.

Calibration starts as one calibration type is selected.

To ensure the best possible weighing results, the mechanical installation must be carried out with great care. Fixed mechanical connections to the scale should be avoided, or made as flexible as possible and perpendicular to the measuring direction. If the scale has several transducers connected in parallel, they must have the same rated load and impedance. If transducers and fixed supports are combined, the load must be evenly distributed on all supports.

It is recommended to start with a data sheet calibration, which is easy to perform and gives a fairly good accuracy so the installation can be tested.

DATA AND CALIBRATION SHEET		ArtNo: 1130480	
LOAD CELL	KIS-3	S/N 322471	
RATED LOAD (R.L)	10 kN	!	EXCITATION VOLTAGE, RECOMMENDED 10 V AC OR DC
OVERLOAD, SAFE	100 % R.L.	!	EXCITATION VOLTAGE, MAXIMUM 18 V AC OR DC
OVERLOAD, ULTIMATE	200 % R.L.	!	INPUT RESISTANCE 350 +/- 3 OHMS INCL. STANDARD CABLE
SIDE LOAD, SAFE	100 % R.L.	!	OUTPUT RESISTANCE 350.1 OHMS INCL. STANDARD CABLE
SIDE LOAD, ULTIMATE	200 % R.L.	!	TEMPERATURE RANGE -40 TO +80 DEGREES C
ELECTRICAL CONNECTION	SHIELDED 4-CONDUCTOR CABLE	!	TEMPERATURE EFFECT (-10 TO +50 DEGREES C)
EXCITATION POSITIVE:	RED	!	
EXCITATION NEGATIVE:	BLACK	!	ON OUTPUT 0.001 % OF OUTPUT PER DEG. C
SIGNAL POSITIVE:	GREEN	!	
SIGNAL NEGATIVE:	WHITE	!	ON ZERO BALANCE 0.001 % OF R.O. PER DEG. C

RATED OUTPUT (R.O.) (TOLERANCE 0.1 %)			2.0394 mV/V
NONLINEARITY (BEST FIT THROUGH ZERO)		+/-	0.010 % R.O.
ZERO BALANCE			+0.0 % R.O.
CREEP 5 MINUTES			+0.001 % R.O.
CALIBRATION VALUES (TOLERANCE 0.1 %) SHUNT RESISTOR CONNECTED BETWEEN 'EXCITATION NEGATIVE' AND 'SIGNAL NEGATIVE'			
40 KOHMS CORRESPOND TO			9.9111 kN
80 KOHMS CORRESPOND TO			4.9683 kN
THE VALUES INDICATED FOR OUTPUT VOLTAGE AND CALIBRATION VALUES ARE APPLICABLE AT OPEN CIRCUIT WITHOUT EXTERNAL BALANCING RESISTORS AND WITH A CONNECTING CABLE OF STANDARD LENGTH.			
Vishay Nobel AB S-691 27 KARLSKOGA		KARLSKOGA 03-04-30	

Each transducer from Nobel Weighing Systems is delivered with a detailed data and calibration sheet.

If the weight indicator must be replaced, a table calibration of the replacement unit can be performed, with recorded values from an earlier calibration.

To get the best accuracy, a deadweight calibration with known weights to at least 2/3 of the measuring capacity, should be performed.

All calibration parameters are found in the menus under 'Scale X' and 'Scale X Calibration'. The parameters are described in section 3 Set-up.

Note that calibration must be done separately for each scale in the instrument.

Actual gross weight and transducer signal is displayed when in menu 'Scale X' or 'Scale X Calibration'.

Common parameters

For all calibration types, measurement unit and resolution for the weight value, and the capacity for the scale must be specified. These parameters, among others, are found in menu 'Scale X', see chapter 3. This section deals only with the calibration parameters.

Measurement unit

This parameter defines the engineering unit used for the weight value.

The same engineering unit will also be used for example in the parameter values 'Resolution', 'Capacity', 'Level', and 'Setpoint'.

Resolution

This parameter defines decimal point position and resolution in weight display.

The decimal point position selected here will be used in setting up, in the displayed weight value and in the weight value sent to a printer or computer.

Resolution is understood to mean the smallest weight change presented.

Capacity

This parameter defines the nominal range of the scale. This is the capacity of the scale and should be set to the maximum weight with which the scale is to be loaded. Even if the scale (transducers) have larger capacity, this value should nevertheless be set so that the weighing vessel does not become over full if the scale is loaded up to this value. This parameter is used to calculate certain default values in the set-up and in checking the maximum zero value (with ZERO key and zero-tracking).

Number of scale divisions

The number of scale divisions (div.) for a scale = 'Capacity' / 'Resolution'.
To get correct and stable weight display, parameter 'Resolution' should be set so that the number of scale divisions with the selected 'Capacity' is less than 6 000 (10 000).

The number of scale divisions is also limited by the performance of the transducers and by how large a portion of the transducer capacity that is actually utilised.

To ensure a stable weight display, the input signal to the instrument should exceed 0.2 μV /scale division.

Example:

- Three transducers, each of 20 000 N (approx. 2 000 kg), are to support a tank which, without contents, weighs 3 500 kg. The amount of material in the tank varies from 0 – 1 000 kg.
- Transducer capacity = 6 118 kg
(3 x 20 000 N / 9.80665).
- Transducer sensitivity = 2.039 mV/V.
- Supply voltage to transducers = 5 V.
- Signal from transducers at full load (6 118 kg) = 10.2 mV
(2.039 mV/V x 5 V).
- Signal change in response to an applied load of 1 000 kg = 1.66 mV
(10.2 mV x 1 000 / 6 118).
- Set 'Capacity' to 1 000 kg.
 1. Set 'Resolution' to 0.1.
Number of scale divisions = 1 000 / 0.1 = 10 000
Signal/scale division = 1.66 mV / 10 000 div. = 0.17 μV /div.
 2. Set 'Resolution' to 0.2.
Number of scale divisions = 1 000 / 0.2 = 5 000
Signal/scale division = 1.66 mV / 5 000 div. = 0.33 μV /div.

It is best to select Case 2, since both the number of scale divisions and signal/div. are on the borderline in Case 1. In some special cases the resolution may obviously be driven higher, but the transducer characteristics must always be observed.

Data sheet calibration

Data sheet calibration is recommended as first-time calibration for a new installation. In data sheet calibration, values from the transducer data sheets are entered as parameter values, the scale need not be loaded and an accuracy of 0.1 % can be obtained. The accuracy of the G4 Instrument itself is 0.005 % (1-2 years calibration period). It is essential that no external forces influence the scale installation. If fixed support points are included in the scale, the load must be evenly distributed on transducers and fixed supports.

Conversion factor

In transducer data sheets, loads are normally not expressed in the measurement unit, selected for the scale. This parameter defines a constant by which a weight value, expressed in the measurement unit, should be multiplied to be expressed in the data sheet unit.

When using a transducer, calibrated in Newton, in a scale displaying weight values in kg, the 'Conv. factor' shall be the local gravitation constant in m/s^2 .

The default value, 9.80665, is an international mean value for the gravitation constant (world-wide range 9.78 – 9.83).

If the data sheet unit is the same as the measurement unit, the conversion factor parameter should be set to 1.0000.

Number of transducers

In weighing applications the load on the scale may be supported by several transducers or fixed supports. This parameter defines the total number of transducers and fixed supports in the scale, up to maximum 4.

If the scale has more than 4 support points, this parameter should be set to '1' and the parameter value for 'Rated load' and 'Rated output' must be calculated.

Rated load

Rated load for a transducer is indicated in the data sheet and should be entered as a parameter value, expressed in the unit of the data sheet.

NOTE! If the data sheet value is 5 kN, this parameter should be set to 5000 (N).

If several transducers are used in a scale, they must all have the same rated load.

If the scale has more than 4 support points, 'Number of transd' should be set to '1' and the value of this parameter should be calculated as:

rated load for one transducer, multiplied by the total number of support points.

Rated Output 1 (2, 3, 4)

Rated output is given in the data sheet for every transducer. Parameters will be available for the number of support points specified in 'Number of transd'.

For fixed support points the rated output value is 0.00000 (mV/V).

If the scale has more than 4 support points, 'Number of transd' should be set to '1' and the parameter value for 'Rated output 1' should be calculated as:

the mean value of rated output for all active transducers.

Set zero

Set zero is useful only when the scale installation is finished. By the digit keys this value can be set to zero, for unloaded scale, or to the weight of the known load, for a scale that is loaded.

Zero offset

For an installed scale this parameter shows the zero offset after zeroing, a value that should not be edited.

For a scale that is not installed it is possible to enter the known weight of fixed equipment on the scale.

Table calibration

Table calibration can be used to copy recorded values from a previous deadweight calibration of the weighing equipment into a replacement instrument. This is performed by entry of recorded weight values and corresponding transducer signal values into the instrument. Calibration can be performed for up to 6 points.

The accuracy of the copying procedure is 0.005 %.

No of Calibration Points

Only parameters for the selected number of calibration points will be displayed in the menu. The number of calibration points can be changed during the calibration.

Value Cal. P1, Value Cal. P2 etc.

These parameters are used for entry of recorded weight values, expressed in the measurement unit, from a previous deadweight calibration.

Transd.Signal P1, Transd.Signal P2 etc.

These parameters are used for entry of recorded transducer signal values for corresponding calibration points.

Set Zero

Set zero is useful only when the scale installation is finished. By the digit keys this value can be set to zero, for unloaded scale, or to the weight of the known load, for a scale that is loaded.

Zero Offset

This parameter is used for entry of the recorded zero offset value from a previous deadweight calibration.

If a zeroing has been performed with parameter 'Set zero' above, the value of parameter 'Zero offset' need not be changed.

Deadweight calibration

This is normally the most accurate calibration type. The transducer signals are measured and automatically stored when the scale is loaded with known weights. Calibration can be performed in up to six calibration points, starting with the lowest, the highest point, or any other order.

Calibration of the lowest point is normally performed with the scale unloaded.

If calibration in two points is used, the second point should be placed as high as possible, the scale should be loaded with at least 2/3 of the 'Capacity'.

By calibration in more than two points, the highest calibration point should be placed at, or higher than, the highest load for which the scale is to be used, and the calibration points should be evenly distributed in the measuring range.

No of Calibration Points

This parameter defines the number of calibration points. Up to six points can be selected, and parameters for load value and transducer signal will be displayed only

for the selected number of points.

It is possible to change the number of points during the calibration.

Value Cal. P1,

This parameter defines the load for the lowest calibration point. Normally the scale should be unloaded and the parameter value set to 0 (zero). This weight value and the corresponding transducer signal value are automatically stored in the instrument.

Value Cal. P2, Value Cal. P3 etc.

The scale should be loaded with known weights. These parameters show the load according to the previous calibration and the parameter values should be changed to the value of the known weights. As a parameter value is stored, the instrument will also store the corresponding transducer signal value for that calibration point.

Transd. Signal P1, Transd. Signal P2 etc.

These parameters contain the automatically stored transducer signal values for the calibration points. The values cannot be edited.

Set Zero

Set zero is useful only when the scale installation is finished. By the digit keys this value can be set to zero, for unloaded scale, or to the weight of the known load, for a scale that is loaded.

Zero Offset

For an installed scale this parameter shows the zero offset after zeroing, a value that should not be edited.

5. Operation

General

G4 instrument with strain gauge transducers is designed mainly for weighing and batching purposes. The measurement values are displayed at the front panel, and can also be transmitted to a master computer/PLC.

The measurement values can also be presented as the output signal from an analog output module.

Some functions in the instrument can be controlled by digital input signals, and digital outputs from the instrument can be used to indicate actual status of instrument, scales, levels and so on. The number of inputs and outputs may be expanded by connection of additional I/O modules.

Power supply

The instrument is powered by 24 VDC or 110/230 VAC and should not be turned off during weekends and over-night. Continuous power supply to electronics and transducers prevents moisture condensation in the units.

Power-up sequence

As the G4 instrument is started it enters the Starting up state.

If any error is detected during power-up, the sequence stops and an error code will be displayed. If the error is not fatal it will be possible to enter the menu system to correct possible set-up errors.

If the detected error is fatal, it will only be possible to select restart unless the error is a database file problem. If the start-up error is a database file error it will be possible to select between deleting the database file, entering program upgrade or restart. Deleting the database or upgrading the program (also upgrading to the present program version) will result in a new database to be created which may make the instrument usable again. Note that settings will be default after creating a new database. If the fatal error persists please contact your supplier.

If no errors are detected, the instrument can enter normal operation (automatic start-up), displaying actual weight values, possibly together with other instrument information.

If 'Manual start-up' is selected, the instrument enters the 'Wait for start' state, displaying a message 'Waiting for start command. Press START to continue!'. When the operator presses the 'START' button on the screen, the instrument will switch over to normal operation unless a warm up time is set and there is still a remaining warm up time. In this case the 'Warming up' message will be displayed. See below.

If a warm up time has been set the message 'Warming up.' will be displayed together with the remaining time. When the warm up time has expired the instrument will switch over to normal operation automatically.

Display alternatives by normal operation

In the operating display it is possible to view weight information from one or more scales. It is also possible to select which scales that shall be displayed on the color touch display. With parameter 'Display modes' it is possible to select what combinations of the three operating display modes that can be selected by the operator. The display modes are single scale display, two scales display and four scales display.

Dedicated keys on the front panel are used to zero and tare the scale, to toggle between gross and net weight display and print weighing results for the selected scale.

Note that information displayed varies between the operating display modes and that the information displayed may be different depending on actual settings.

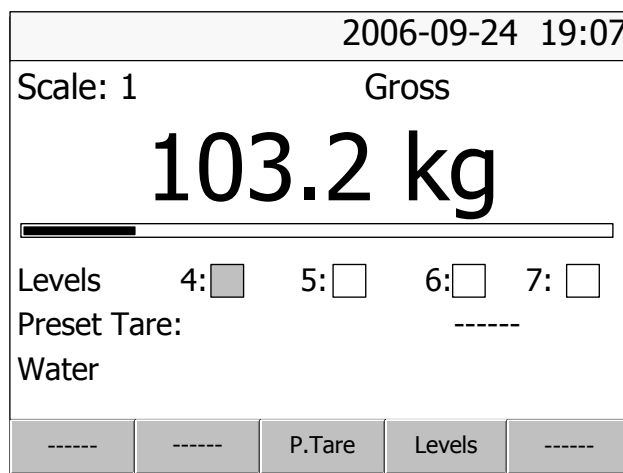

Single scale operating display mode.

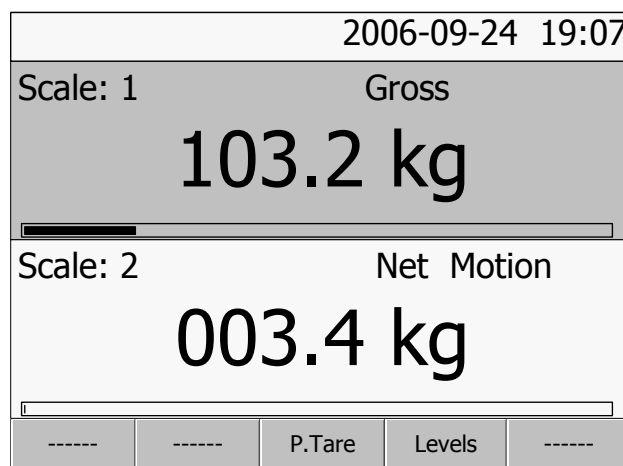

Two scales operating display mode.

2006-09-24 19:07				
Scale: 1		102.1 kg		
Gross	Zero			
Scale: 2		000.0 kg		
Net	Zero			
Scale: 3		000.0 kg		
Net	Zero			
Scale: 4		004.9 kg		
Gross				
-----	-----	P.Tare	Levels	-----

Four scales operating display mode.

Using the right/left arrow keys will scroll through the three different operating display modes unless limitations are set with parameter 'Display modes'. To scroll between the available scales the up/down arrows on the instrument front panel are used.

From the operating display it is possible to directly reach functions related to individual scales by pressing one of the soft function keys on the touch display.

These functions are:

P. Tare: Showing and setting the (manual) preset tare for the selected scale.

Levels: Setting the level of the level supervisors for the selected scale. Note that the parameters for the level supervisors, such as scale, source, hystereses range, and so on are accessed through the 'Parameter Set-up' menu.

If the operator lock is on the user is required to enter the operator lock code before any changes of 'P. Tare' or 'Levels' values can be made.

Shortcuts

Following commands will take you directly to wanted scale indication.

- **Enter** Takes you directly to Single scale window with selected scale active
- Entry of **digit 1-8** Selection of scale no. corresponding to the digit.

Security locks

In the G4 instrument two security locks are included to prevent unauthorised access to the instrument via the panel keys. The locks can be activated by parameters in menu 'Main menu/Parameter set-up/General'.

The following requires a login password if the corresponding lock is on.

Changing instrument clock:	Operator lock.
Changing Preset Tare:	Operator lock.
Changing Levels:	Operator lock.
Changing set-up parameters:	Set-up lock (Operator lock).
Entering/using Backup Menu:	Set-up lock (Operator lock).
Entering/using Restore Menu:	Set-up lock (Operator lock).
Entering/using Default Menu:	Set-up lock (Operator lock).
Entering/using Program Upgrade Menu:	Set-up lock (Operator lock).
Entering/using File handling Menu:	Set-up lock (Operator lock).
Changing Network Config:	Set-up lock (Operator lock).

Entering set-up code gives access also to operator locked functions. If only operator lock is on, the operator code is required where set-up lock is specified above.

Unlocking of "P.Tare" and "Levels" editing from the main picture, is valid until you return to the main picture.

Unlocking of any function under the Main Menu, is valid until you leave the Main Menu.

Codes for the security locks

When a security lock is activated the operator must enter a four digit code to get access to the protected area. By default the valid code for both locks is '1 9 3 7' , but the locks are not activated.

In menu 'Parameter Set-up', sub menu 'General', parameters are available to activate the locks and to change the default code to any four-digit code.

The code for the Operator lock can only open the Operator lock.

The code for the Set-up lock will open both Set-up lock and Operator lock.

Taring

Taring means storing of a tare value and that the G4 instrument switches over to display of net weight. The net weight being the gross weight minus the tare value. In the instrument two tare values can be stored, Auto tare and Preset tare.

'Auto' tare value is the actual gross weight, stored as tare value when the TARE key is pressed.

'Preset' tare is a tare value that can be entered only if the instrument is set to use Preset tare. The value of Preset tares, for any of the 'configured' scales, can be entered in sub menu 'Preset tare' under the instrument Main menu. Preset tare for the selected (shown) scale can be set in sub menu 'Preset tare' reached with button F3 / 'P. Tare' directly on the operations menu.

'Preset tare' can also be entered from a master unit by serial communication.

Calibration parameter 'Tare corr.mode' defines the use of 'Auto', 'Preset', or the sum 'Auto+preset' by taring.

Auto Only 'Auto tare' is used. 'Preset tare' value cannot be entered or edited.

Preset Only 'Preset tare' is used.

Auto+preset The sum of the 'Auto tare' and 'Preset tare' values is used.

When the TARE key is pressed, the actual gross weight is stored as Auto tare value and the instrument will display net weight = '- Preset tare'.

With default setting, taring can be performed, even if the weight is not stable. But if parameter 'Motion check' in 'Parameter Set-up / Calibration' for the scale is set to 'On', taring will be allowed only when the weight value is stable.

If Calibration parameter 'Overload Check' is set to 'Unipolar', taring is not allowed at negative gross weight.

Taring example:

A combination of Preset tare and Auto tare is useful in weighing operations when it is inconvenient or impossible to separate a packing and its contents.

- The packing must be weighed to establish a 'known weight' for it.
- Go to menu 'Calibration/Scale 1' for the actual scale (in this example scale 1) and set parameter 'Tare corr.mode' to Auto+preset.
- Go to menu 'Preset tare' by pressing F3 / 'P.Tare' button on the screen. Enter the packing weight as the Preset tare value.
- Press the TARE key when the scale is not loaded, or loaded with permanent help equipment only. The Preset tare value will be displayed as negative net weight.
- Put the packing with contents on the scale.
The weight of the contents will be displayed as net weight.

Gross/Net operation

At normal operation the G4 instrument presents a numerical weight value at the display, either gross weight or net weight. When net weight is displayed the text 'Net' is shown on screen.

Toggleing between display of gross weight and net weight can be performed by pressing the GROSS/NET key. Note that toggling is done only for the selected scale in case of more than one scale displayed on screen the selected one is indicated with a yellow background on the display.

Gross weight is continuously shown in form of a graphic bar on one and two scale displays. Maximum length of the bar corresponds to the set Capacity of the scale. Net weight is the difference between gross weight and a tare value. For calculation of net weight, the instrument can use either 'Preset' tare, 'Auto' tare, or the sum of them.

Net weight cannot be displayed if the tare value in use is zero (0).

Zero setting

A basic zero setting of the gross weight is performed as part of the calibration for the scale. If changes to the weighing equipment are made later a renewed calibration, or at least the zero setting of a calibration, should be performed.

Minor correction of the zero value may be needed and can rapidly be performed:

When a gross weight close to zero is displayed, pressing the ZERO key will make the gross weight zero.

Pressing the ZERO key will also set the value of 'Auto tare' to zero.

Zero setting with the ZERO key is permitted only if:

- the weight is stable (the text 'Motion' not shown), and
- the accumulated zero correction since last calibration is between -1 % and +3 % of the 'Capacity', over and above the zero offset obtained when the instrument was calibrated last time.

The text 'Zero' will be shown on the display when the displayed weight is a 'good zero', meaning that the weight deviates from zero with less than one quarter of the set 'Resolution'.

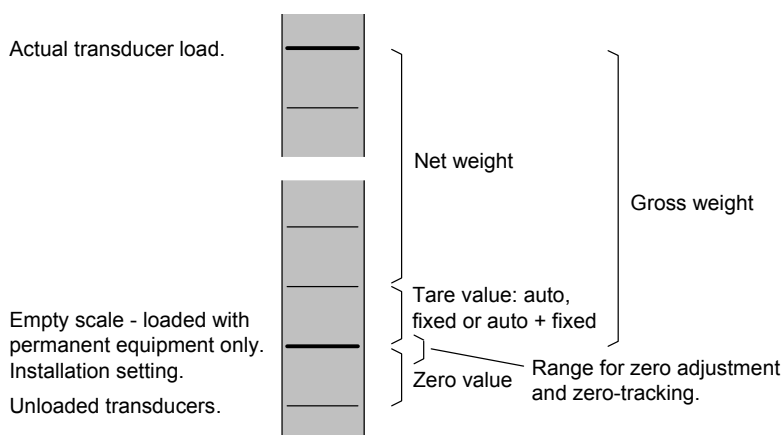

Correlation between gross weight, net weight, and tare value for a scale.

Zero-tracking/Automatic zero setting

In the instrument the functions zero-tracking and automatic zero setting can be enabled. Zero-tracking gives a continuous zero setting by slow changes in zero weight. The automatic zero setting performs zeroing of small negative gross weights. For both functions the following requirements should be met:

- The zero point stays within the permissible range, deviation from calibrated zero less than -1 % to +3 % of Capacity.
- No setpoint function is activated (armed).

Zero-tracking

Zero-tracking is active when, in addition to the common requirements above, the following requirements are met:

- Calibration parameter 'Zero-tracking' is set to On or On+AutoZero.
- The gross weight is 'good zero' (deviation from zero less than one quarter of Resolution).
- The weight is stable (the text Motion not shown).
- The rate of weight change is lower than the 'zero-track.rate', see below.

The set-up parameter 'Zero-track.rate' determines the maximum permissible weight change per minute for the zero-tracking. If parameter 'Resolution' is changed, the value of 'Zero-track rate' will change correspondingly.

Automatic zero setting

Automatic zero setting is active when, in addition to the common requirements above, the following requirements are met:

- Calibration parameter 'Zero-tracking' is set to On+AutoZero.
- The gross weight is negative.
- The actual scale is in gross mode.
- The weight has been stable (the text Motion not shown) for 5 seconds.

Motion

The text 'Motion' may be shown to the right in the display. Motion condition exists if the weight change during a certain measurement period is greater than the window 'Motion Detect Window'. The measuring period is one conversion time ('Update Rate') or at least 200 ms.

After the weight becomes stable, the text 'Motion' will still be shown for a short time, specified in parameter 'No-motion delay', instrument will regard the weight as unstable until the text 'Motion' has disappeared.

When the text 'Motion' is shown, the following activities are affected:

- Zero setting can not be performed.
- Zero-tracking can not be performed.
- Taring can not be obtained (applies if 'Motion check' is 'On').
- Printout of weights is delayed until stable weight is obtained (applies if 'Motion check' is 'On').

Main menu

To reach the main menu, press the 'Info' button on the instrument front panel.

Navigating in a menu is done with arrow keys or by tapping on the display on specific choices e.g. 'Parameter set-up'.

To open a sub menu, e.g. Parameter set-up, select the sub menu with arrow keys followed by pressing the 'Enter key', or by tapping on the name.

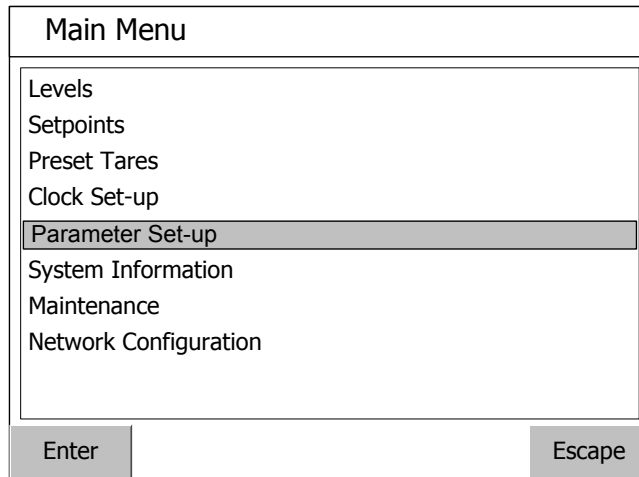

Main menu.

The instrument Main menu can be opened without interrupting the weighing operation.

In the Main menu it is possible to select between the following sub menus:

Levels: Viewing and editing of level value for each configured Level Supervision function. Note that configuration of Level Supervision functionality is done in the 'Parameter Set-up' menu.

Setpoints: Viewing of configured setpoint values. Editing of setpoint value is not possible. Note that configuration of setpoint functionality is done in the 'Parameter Set-up' menu.

Preset Tares: Viewing and editing of preset tares values for scales with tare correction mode set to Preset or Auto + Preset. Set-up of Scale 'Tare Corr. Mode' parameter is done in the 'Parameter Set-up' menu.

Clock Set-up: Used to set the instrument clock and date. Time and Date formats are set-up with parameters through 'Parameter set-up' menu.

Parameter Set-up: Access to the G4 instrument parameter set-up menu system. See chapter 3 Set-up for more details on setup.

System Information: Displaying system information for hardware and software in the instrument. Program versions, database version, serial numbers and software versions for all electronic modules can be read here. Info about the Ethernet connection is also available.

Maintenance: Includes the following functions used for maintenance purposes:

Create Backup: Parameter values are stored in a file that can be used to restore to same or other instruments of the same type. The user can select to save the back-up file either in the instrument or on a connected USB memory. The file name can be edited. Note that additional information, which is saved in the backup file, can be given before the backup file is created.

Restore Backup: Restoring a previously stored parameter backup to the instrument. Any additional information in the backup file is displayed before a backup file is restored. Backup files can be fetched from internal memory or from a USB memory.

Set Default: Setting the set-up parameter values to factory default settings. All Zero offsets, Auto tares, Preset tares, Levels and Setpoints will be reset to zero when executing a default set-up.

File Handling: Copying, moving (renaming) and deleting files. The file handling is used to manage files in the instrument.

Files can be copied and moved between folders in the instrument and between a USB memory and the instrument (both to and from the USB memory). File can be renamed while copying or moving.

It is possible to delete files stored in the instrument and on a USB memory.

The file handling has access to the 'user tree' directory structure in the instrument. The default folders are 'InstrBackup', 'Misc' and 'Recipes'. The folder 'InstrBackup' is used as default when creating or restoring backup.

Program Upgrade: Upgrading the program with a different version.

Upgrading is normally done from a USB memory. When upgrading the user is asked to select the version to upgrade to by selecting an 'Upgrade.txt' file that is situated within the folder containing all files and folders necessary for program upgrade. When upgrading is done (a success message is displayed) the instrument will be restarted. Note that it may take a few minutes for the instrument to restart after upgrading.

In case of failure when upgrading an error message will be displayed and the user will be given a possibility to recover from the failed upgrade. Corrupt files or malfunctioning USB memory are possible causes of upgrade failing.

Note that the folder containing the program upgrade must not be tampered with but always handled as a whole. Any changes are likely to make the upgrade worthless and making the instrument defective.

Network Configuration: Configuration of the Ethernet network connection of the instrument. Either can the configuration be automatically assigned or manually entered. Note that Ethernet configuration is not done with set-up parameters and is for that reason not saved with the instrument back-up function.

To return to the operating menu press the 'Esc' key on the front panel or the 'Esc' button on screen.

Level supervision

The G4 instrument contains 32 supervision Levels that can be used to supervise defined signals in the instrument. Digital outputs can be connected as outputs for the Levels. For each Level, supervised scale, hystereses and operation mode for the digital output is controlled by set-up parameters.

Functions for Level supervision are defined in menu 'Parameter Set-up' by parameters in the sub menus 'Level Supervision' and 'Outputs'.
See section 3 Set-up.

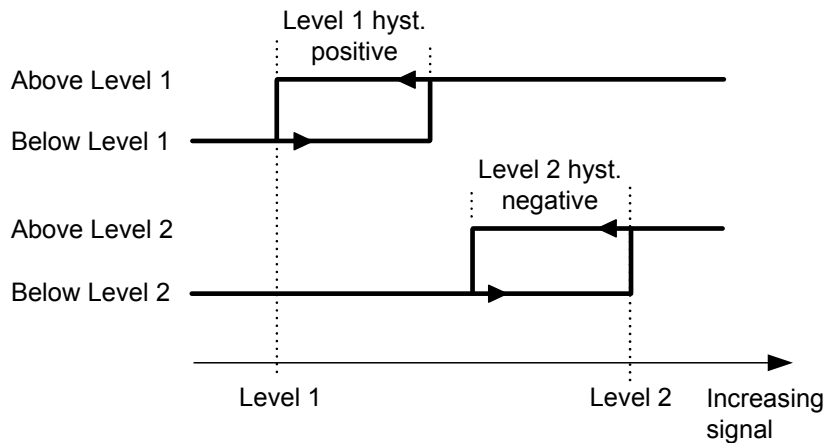

Influence on the level supervision from positive hystereses, for Level 1, and negative hystereses, for Level 2.

'Level X Source'

Set to 'Not in use' will disable level X.

Select 'Net Weight' or 'Gross Weight' to supervise these weight values, independent of which weight that is actually displayed.

Select 'Display Weight' to supervise either gross weight or net weight, depending on which weight that is actually displayed.

'Flow rate' can only be used if the parameter 'Flow Calculation' is activated (On) for a scale in the Parameter Set-up.

Select 'Abs.Net Weight', 'Abs.Gross Weight', 'Abs.Disp.Weight' or 'Abs.Flow Rate' to act on the absolute value of these signals, i.e. the value independent of polarity.

'Level X Scale'

The parameter 'Level X scale' is set to the scale no (1 – 8) that the supervision level shall supervise.

'Level X Output':

Defines how a digital output, if connected to the Level, should operate.

The parameter can be set to make an output active when the signal is above the Level, or when it is below the Level.

'Level X Hystereses':

Defines the width of a hystereses range for the Level. The definition of a negative hystereses range starts with a minus sign(-).

Hystereses is an intentional difference between the switch levels for increasing and decreasing signal level. One switch level is always at the defined Level.

The other switch level is at a higher level by positive hystereses, at a lower level by negative hystereses. See figure.

Level status

Actual status of the Levels (input signal above or below Level) can be read via communication and shown at the display (the four first for each scale).

The level status includes the influence from hystereses, but it does not show the status of any digital outputs, connected to the Levels.

Setpoint function

General

The 16 Setpoints can be used for fast, accurate and reliable supervision of weight values. The Setpoint function is of a one shot type, the function is activated by a command from the master computer/PLC and deactivated when the weight has reached the Setpoint value.

The Setpoints can be connected to any digital output in the instrument for flexibility.

The Setpoints can only be controlled by a master computer/PLC via serial communication.

NOTE: To ensure good operation during the time when a setpoint is activated, the zero-tracking function is not working.

Set-up

The selection of the setpoint functions is made in set-up parameters "Setpoint X Source" and "Setpoint X Scale". In these set-ups you can select which scale and what signal (weight value) the setpoint shall act on.

Connection of a setpoint to an output is made in set-up menu "Outputs".

Operation

The wanted setpoints (weight levels) must be loaded into the corresponding Modbus registers.

The setpoint(s) are activated by communication. If a setpoint is connected to an output, then corresponding digital output is activated.

When the selected weight becomes higher than the setpoint the setpoint function is deactivated and the corresponding "Setpoint X cycle done" bit is set. A possible connected digital output is also deactivated at the same time.

The setpoint function, and possible connected digital outputs, can also be deactivated by sending command "Deactivate setpoint X".

NOTE The "Setpoint X cycle done" for a setpoint is reset when the setpoint value is loaded and when the setpoint is activated.

Use of inputs and outputs

Internal I/O's are included on some of the I/O-modules that the G4 instrument can be equipped with. Different module types have different number of inputs and outputs. A DIO8 module have 8 inputs and 8 outputs while the weight conversion modules HS WF2, WF IN and WF IN2 each have 4 inputs and 2 outputs.

All input and output functions are controlled by set-up parameters in the instrument.

Digital inputs

The digital inputs can be used for remote operation of the instrument.

Digital outputs

The digital outputs can be used for control of external equipment and for indication of instrument status.

Analog outputs

To produce analog outputs from the G4 instrument, a one channel AOUT1 or a four channel AOUT4 module is used.

The analog output signal will represent a selected signal in the instrument in form of an analog current or voltage signal.

All analog output functions are defined by parameters in sub menu 'Analog outputs', see chapter 3 Set-up.

Filter function

In the instrument the weight value is produced in two forms, unfiltered and filtered. The 'unfiltered' weight is actually also filtered but with a faster filter than the 'filtered' weight value but for simplicity it is called unfiltered.

The unfiltered weight value represents the transducer load with the smallest delay. This means that the instrument will respond rapidly to changing load, but the weight display will be unstable if the load is fluctuating. The filtered weight value will give a smoother weight display, but the response on changing load will be delayed. Weight values are produced within the instrument at the selected 'Update Rate'.

Switching between filtered and unfiltered weight

The instrument automatically switch between unfiltered and filtered weight in order to make the weight display fast when the load on the scale changes, but stable for constant load. The parameter 'Filter window' controls the switching between filtered and unfiltered weight.

The scale will switch to filtered weight when the difference between the filtered weight and unfiltered weight values is smaller than 'Filter window'.

The scale will switch to unfiltered weight if the difference between the filtered weight and unfiltered weight values is larger than 4 times 'Filter window'.

Filter characteristics.

The parameter 'HSWF Update Rate' / 'WFIN Update Rate' selects the update rate and filter characteristics of the weight conversion. The two different types of weight conversion modules have different ranges of settings.

The filter of the G4 Multi Channel Weighing Instrument will very effectively suppress any disturbances at frequencies above the -90 dB frequency.

WF IN / WF IN2 module filter bandwidth

Update rate	- 3 dB frequency		- 90 dB frequency	
	Filtered	Unfiltered	Filtered	Unfiltered
300 Hz	14 Hz	22 Hz	75 Hz	150 Hz
150 Hz	7.6 Hz	14 Hz	37 Hz	75 Hz
75 Hz	3.9 Hz	7.6 Hz	19 Hz	37 Hz
37 Hz	2.0 Hz	3.9 Hz	9 Hz	19 Hz
19 Hz	1.0 Hz	2.0 Hz	4.5 Hz	9 Hz
9.3 Hz	0.5 Hz	1.0 Hz	2.3 Hz	4.6 Hz
4.6 Hz	0.25 Hz	0.5 Hz	1.2 Hz	2.3 Hz
2.3 Hz	0.12 Hz	0.25 Hz	0.6 Hz	1.2 Hz

HS WF2 module filter bandwidth

Update rate	- 3 dB frequency		- 90 dB frequency	
	Filtered	Unfiltered	Filtered	Unfiltered
800 Hz	34 Hz	48 Hz	200 Hz	400 Hz
400 Hz	19 Hz	34 Hz	100 Hz	200 Hz
200 Hz	10 Hz	19 Hz	50 Hz	100 Hz
100 Hz	5.2 Hz	10 Hz	25 Hz	50 Hz
50 Hz	2.6 Hz	5.2 Hz	12 Hz	25 Hz
25 Hz	1.3 Hz	2.6 Hz	6 Hz	12 Hz
12.5 Hz	0.75 Hz	1.3 Hz	3 Hz	6 Hz

WF IN / WF IN2 Filter rise time

Update rate	Rise time	
	Filtered	Unfiltered
300 Hz	0.075 s	0.04 s
150 Hz	0.15 s	0.08 s
75 Hz	0.30 s	0.16 s
37 Hz	0.60 s	0.32 s
19 Hz	1.2 s	0.64 s
9.3 Hz	2.4 s	1.3 s
4.6 Hz	4.7 s	2.6 s
2.3 Hz	9.4 s	5.1 s

HS WF2 Filter rise time

Update rate	Rise time	
	Filtered	Unfiltered
800 Hz	0.028 s	0.015 s
400 Hz	0.055 s	0.030 s
200 Hz	0.11 s	0.060 s
100 Hz	0.22 s	0.12 s
50 Hz	0.44 s	0.24 s
25 Hz	0.88 s	0.48 s
12.5 Hz	1.8 s	0.96 s

Rise time is defined as the time from an ideal step input to output reaches 99 % of the input step. Note that in reality no input changes will be an ideal step. Input signals are affected by mechanical time constants and how the weight is applied to the scale.

Flow rate

General

The G4 instrument includes function for flow measurement. The flow rate value can be shown on the display, checked by the level supervision, sent to an analog output and it can also be fetched by serial communication.

Operation

The G4 instrument calculates the flow by measuring the weight change during a selected integration time and dividing by the time.

The flow rate can be displayed as weight change per second, per minute or per hour.

It will display weight or flow value, and switch over between weight and flow is accomplished with the function key 'W/F' or 'F5'.

Switch over can also be accomplished by a digital input or a serial communication command.

Changing and storing

Parameters entered to define flow rate parameters will not be lost if the instrument is switched off.

Parameter editing can be performed in menu 'Param. Set-up/Calibration' where Scale 'X' is selected, by the panel keys. Note that there are flow rate parameters for each scale in the instrument. Flow calculation is set-up individually for each scale.

Setting of flow rate resolution

Parameter 'Flow rate resolution' defines the decimal point position and resolution for the flow rate value. All set-up parameters using the flow rate unit will be written with the decimal point position selected in this menu. If the last digits of the flow rate value are not stable, a more coarse resolution can be selected to get a stable reading. A more coarse resolution will also result in a shorter derivation time (if 'Auto Derivation Time' is set to 'On').

Setting of flow rate unit

Parameter 'Flow Rate Unit' defines the engineering unit that should be used for the flow rate value and for related set-up parameters.

If the flow rate unit exceeds 4 characters then it will be represented as "/s", "/min", "/h", "*/mi" or "*/h" in the set-up menus.

In the case of "Unit*1000/m" or "Unit*1000/h" then some flow rate units will be preceded by a "k".

Other flow rate units will be converted, according to the table below.

Measurement unit	Flow rate unit * 1000
kg	t
kN	MN
kPa	Mpa
MPa	GPa
l	m ³
kgf	Mgf
kN/m	MN/m
mV/V	V/V

Setting of flow rate derivation time

To enable the instrument to make a correct measurement of flow rates, a derivation time must be selected in accordance with the desired accuracy.

If 'Auto Derivation Time' is set to 'On' then the instrument will calculate a derivation time based on the current calibration (including update rate), the 'Flow Rate Resolution' and the 'Flow Rate Unit'. The instrument tries to calculate a derivation time that will give a stable and accurate flow rate value at the current settings (provided that the flow is stable).

A longer filter time and/or a more coarse 'Flow Rate Resolution' will give shorter derivation times. The automatically calculated derivation is limited to its defined max. and min. values.

If 'Auto Derivation Time' is set to 'Off', then the 'Derivation Time' must be entered manually. The instrument will accept any derivation time (within its min. and max. limits) and it is up to the user to select a suitable derivation time for the application. When the scale update rate or the derivation time is changed the derivation time is adjusted, by the instrument, to the nearest possible value depending on the update rate.

Flow rate update time

The flow rate value is updated as shown in the table below. At start-up the accuracy of the flow rate will not gain full precision until after a full derivation time period.

Number of weight conversions per derivation time period	Flow rate value update interval
≤ 100	Every weight conversion
> 100 but ≤ 200	Every second weight conversion
> 200 but ≤ 300	Every third weight conversion
And so on	And so on

Flow rate value to analog output

The flow rate value can be obtained on a connected analog output. The settings for analog outputs are found in the menu 'Analog outputs' (section 3 in this manual).

Supervision of the flow rate value

It is possible to level supervise the flow rate value and use it in the setpoint function. The settings for level supervision and setpoint functions are found in the menus 'Level 1' to 'Level 32' and 'Setpoints' (chapter 3 in the manual).

Serial communication

The flow rate value can be read from a register by using serial communication. It's also possible to control if flow rate or weight should be shown on the display.

Hints and examples

First of all it is important to have a good weighing application where you use the load cells in a good way to get high resolution and accuracy. It is possible to use long filter time in the instrument to get a higher resolution and accuracy. To get rid of noise it's important to have as high signal from the load cells as possible.

Example:

We assume that you can calibrate the scale to get a stable weight reading with resolution 0.2 kg (use longer filter time if necessary).

The flow rate function measures the weight difference during one derivation time and we assume that we can get a weight error less than one weight division.

- A derivation time of 10 seconds gives a flow rate error of:
 $0.2 / 10 = 0.02 \text{ kg/s (72 kg/h)}$
- A derivation time of 100 seconds gives a flow rate error of:
 $0.2 / 100 = 0.002 \text{ kg/s (7.2 kg/h)}$

In an application where you have a nominal flow rate of 1500 kg/h you will get an error of:

$72 / 1500 = 4.8 \%$ for a derivation time of 10 seconds and

$7.2 / 1500 = 0.48 \%$ for a derivation time of 100 seconds in this example.

If it is possible to calibrate the scale with a better resolution (you still need to have a stable weight) then you can achieve a better flow rate accuracy and/or a shorter derivation time.

NOTE!

The flow rate calculation is not depending on the final selected weight resolution.

6. Communication

General

The G4 Instrument has two serial communication ports, one Ethernet port and an optional fieldbus module.

The serial communication ports, the Ethernet port and the optional fieldbus interface module are used for communication with a control unit.

Serial interface

The instrument is equipped with 2 serial communication ports: COM1, COM2. COM1 is a RS-232 port and COM2 is a RS-485 port

The COM2 serial communication utilises RS-485 for 2-wire or 4-wire. RS-485 is an interface working with differential voltages, giving a noise resistant transmission in a network with several units and long distances. The host computer (master) must have an asynchronous communication port for RS-485, or use a converter for RS-232 to RS-485 conversion or USB to RS-485.

If 2-wire transmission is used, the control unit must be capable of data flow direction control or utilise a converter for automatic data flow direction control. When 4-wire transmission is used, no data flow direction control is needed.

When the RS-232 port is used it's possible to communicate with one instrument directly from a PC with a RS-232 port without using a converter.

Modbus RTU Slave

General

All the G4 units connected to the network can listen to what is transmitted in the network, but only one unit at a time may transmit. A time-sharing principle is needed to allow communication in both directions (half duplex).

All communication in the network must be initiated by the control unit (master). When the instrument is working together with a master the instrument units are all slaves, only allowed to reply to master commands. As the master has addressed a command message to a specific slave unit, it listens for the reply during a specified time, before sending next command message.

If the reply from a slave unit fails it may be due to:

- Mismatch in communication parameters. (baud rate, address, . . .)
- More than one slave unit has been transmitting at the same time. This can distort the reply message and make it impossible to decode.

See '6 Communication – Modbus protocol' section for detailed information of register numbering, register content definition, commands etc.

More information about Modbus RTU can be found at 'www.modbus-ida.com' and many other places.

Setup of Modbus RTU communication

- The instrument will as default be given the address 1. If more than one instrument is used in a network, each G4 instrument must be given a unique address in parameter 'Modbus address' (in 'Parameter set-up', menu 'Communication', sub menu 'Serial Com').
- Set parameter 'COMx:Mode' to 'Modbus slave'.
- Select correct baud rate and data format in parameter 'COMx:Baudrate' and 'COMx>Data format'.
- Select wanted type of float values in parameter 'COMx:Float Format'.
- When longer response times are needed, set 'COMx:Min reply time' to a suitable value.

Modbus TCP Slave

General

The Ethernet communication port can be used to communicate with the instrument using the Modbus TCP protocol. The instrument is a Modbus TCP slave and will only respond to incoming messages from a master.

See '6 Communication – Modbus protocol' section for detailed information of register numbering, register content definition, commands etc.

More information about Modbus TCP can be found at 'www.modbus-ida.com' and many other places.

Setup of Modbus TCP Slave communication

- Network configuration (IP-address, netmask,...) must be done from menu 'Network Configuration'.
- Enable the Modbus TCP Slave by setting parameter 'Modbus TCP Slave' to 'On' in menu 'Ethernet'.
- Select wanted type of float values in parameter 'Floating point format' (in menu 'Ethernet').

Modbus protocol

For communication with a master computer (PLC) the Modbus protocol is used in the instrument. The Modbus protocol is a standard protocol, used for master/slave communication in the industry.

Information is transmitted in blocks of data to minimise polling and response time delays. For example the error register, status register and weight register could be read with one command to the instrument.

When a command that cannot be performed is sent, the instrument responds with an exception code. For a better explanation of the error, a special command error register could be read.

Depending on the type of the communicating equipment (the master), the commands in the application programme (PLC programme, or pc programme) may be different from type to type. However, if the master is not a Modicon PLC system, then the Modbus implementation in the master must have some cross-reference function to transfer the Modbus register and I/O bit numbering to the masters own register and I/O bit numbering. All registers and coils described in this manual use the standard Modbus (Modicon) register and I/O numbering.

See the master's own Modbus driver documentation for how the commands should be activated in the master's application programme.

Most manufacturers of PLC systems and HMI and SCADA software can provide Modbus drivers. Various Modbus drivers for development of Windows programs are also available on the market.

More information about Modbus protocol can be found at 'www.modbus-ida.com' and many other places.

General registers

The G4 instrument has a number of Modicon 'Holding Registers' (registers 4XXXX ...). The Modbus function 03 'Read Holding Registers' should be used to read these registers and the Modbus function 05 'Preset Single Register' or 16 'Preset Multiple Registers' should be used to write to the registers.

See section 'Data representation' for a description of the different data formats used.

Hint: To find out which of the float formats that should be used, read the 'Instrument type' register (44000), which equals '4001' for the instrument.

Data type: Integer	Data type: float (2 reg./value)	Explanation	R/W
40001 (1 reg)	44000	Instrument type	R
40002 (1 reg)	44002	Standard program major version	R
40003 (1 reg)	44004	Standard program minor version	R
40004 (1 reg)	44006	Special program major version	R
40005 (1 reg)	44008	Special program minor version	R
40006 (3 reg)	44010	Serial number	R
40030 (1 reg)	44030	Command error	R
40031 (1 reg)	44032	Instrument state	R
40032 (1 reg)	44034	Instrument error	R
40033 (1 reg)	44036	Instrument status	R
40034 (1 reg)	44038	Scale 1: Error code	R
40035 (1 reg)	44040	Scale 1: Status	R
40036 (3 reg)	44042	Scale 1: Gross weight	R
40039 (3 reg)	44044	Scale 1: Net weight	R
40042 (3 reg)	44046	Scale 1: Flow rate	R
40045 (3 reg)	44048	Scale 1: Input signal (mV/V)	R
40048 (1 reg)	44050	Scale 2: Error code	R
40049 (1 reg)	44052	Scale 2: Status	R
40050 (3 reg)	44054	Scale 2: Gross weight	R
40053 (3 reg)	44056	Scale 2: Net weight	R
40056 (3 reg)	44058	Scale 2: Flow rate	R
40059 (3 reg)	44060	Scale 2: Input signal (mV/V)	R

Data type: Integer	Data type: float (2 reg./value)	Explanation	R/W
40062 (1 reg)	44062	Scale 3: Error code	R
40063 (1 reg)	44064	Scale 3: Status	R
40064 (3 reg)	44066	Scale 3: Gross weight	R
40067 (3 reg)	44068	Scale 3: Net weight	R
40070 (3 reg)	44070	Scale 3: Flow rate	R
40073 (3 reg)	44072	Scale 3: Input signal (mV/V)	R
40076 (1 reg)	44074	Scale 4: Error code	R
40077 (1 reg)	44076	Scale 4: Status	R
40078 (3 reg)	44078	Scale 4: Gross weight	R
40081 (3 reg)	44080	Scale 4: Net weight	R
40084 (3 reg)	44082	Scale 4: Flow rate	R
40087 (3 reg)	44084	Scale 4: Input signal (mV/V)	R
40090 (1 reg)	44086	Scale 5: Error code	R
40091 (1 reg)	44088	Scale 5: Status	R
40092 (3 reg)	44090	Scale 5: Gross weight	R
40095 (3 reg)	44092	Scale 5: Net weight	R
40098 (3 reg)	44094	Scale 5: Flow rate	R
40101 (3 reg)	44096	Scale 5: Input signal (mV/V)	R
40104 (1 reg)	44098	Scale 6: Error code	R
40105 (1 reg)	44100	Scale 6: Status	R
40106 (3 reg)	44102	Scale 6: Gross weight	R
40109 (3 reg)	44104	Scale 6: Net weight	R
40112 (3 reg)	44106	Scale 6: Flow rate	R
40115 (3 reg)	44108	Scale 6: Input signal (mV/V)	R
40118 (1 reg)	44110	Scale 7: Error code	R
40119 (1 reg)	44112	Scale 7: Status	R
40120 (3 reg)	44114	Scale 7: Gross weight	R
40123 (3 reg)	44116	Scale 7: Net weight	R
40126 (3 reg)	44118	Scale 7: Flow rate	R
40129 (3 reg)	44120	Scale 7: Input signal (mV/V)	R

Data type: Integer	Data type: float (2 reg./value)	Explanation	R/W
40132 (1 reg)	44122	Scale 8: Error code	R
40133 (1 reg)	44124	Scale 8: Status	R
40134 (3 reg)	44126	Scale 8: Gross weight	R
40137 (3 reg)	44128	Scale 8: Net weight	R
40140 (3 reg)	44130	Scale 8: Flow rate	R
40143 (3 reg)	44132	Scale 8: Input signal (mV/V)	R
40170 (3 reg)	44150	Analog output value 1	R
40173 (3 reg)	44152	Analog output value 2	R
40176 (3 reg)	44154	Analog output value 3	R
40179 (3 reg)	44156	Analog output value 4	R
40182 (1 reg)	44158	Status of inputs 11 - 18, 21 - 28	R
40183 (1 reg)	44160	Status of inputs 31 - 38, 41 - 48	R
40184 (1 reg)	44162	Status of inputs 51 - 58, 61 - 68	R
40185 (1 reg)	44164	Status of outputs 11 - 18, 21 - 28	R
40186 (1 reg)	44166	Status of outputs 31 - 38, 41 - 48	R
40187 (1 reg)	44168	Status of outputs 51 - 58, 61 - 68	R
40188 (1 reg)	44170	Level status 1 – 16	R
40189 (1 reg)	44172	Level status 17 – 32	R
40190 (1 reg)	44174	Setpoint status 1 – 8	R
40191 (1 reg)	44176	Setpoint status 9 – 16	R
40230 (1 reg)	44200	Clock: Year	R
40231 (1 reg)	44202	Clock: Month	R
40232 (1 reg)	44204	Clock: Day	R
40233 (1 reg)	44206	Clock: Hour	R
40234 (1 reg)	44208	Clock: Minute	R
42000 (1 reg)	46000	Command register	R/W *

Data type: Integer	Data type: float (2 reg./value)	Explanation	R/W
42010 (3 reg)	46010	Scale 1: Preset tare value	R/W
42013 (3 reg)	46012	Scale 2: Preset tare value	R/W
42016 (3 reg)	46014	Scale 3: Preset tare value	R/W
42019 (3 reg)	46016	Scale 4: Preset tare value	R/W
42022 (3 reg)	46018	Scale 5: Preset tare value	R/W
42025 (3 reg)	46020	Scale 6: Preset tare value	R/W
42028 (3 reg)	46022	Scale 7: Preset tare value	R/W
42031 (3 reg)	46024	Scale 8: Preset tare value	R/W
42034 (3 reg)	46026	Level 1 value	R/W
42037 (3 reg)	46028	Level 2 value	R/W
42040 (3 reg)	46030	Level 3 value	R/W
42043 (3 reg)	46032	Level 4 value	R/W
42046 (3 reg)	46034	Level 5 value	R/W
42049 (3 reg)	46036	Level 6 value	R/W
42052 (3 reg)	46038	Level 7 value	R/W
42055 (3 reg)	46040	Level 8 value	R/W
42058 (3 reg)	46042	Level 9 value	R/W
42061 (3 reg)	46044	Level 10 value	R/W
42064 (3 reg)	46046	Level 11 value	R/W
42067 (3 reg)	46048	Level 12 value	R/W
42070 (3 reg)	46050	Level 13 value	R/W
42073 (3 reg)	46052	Level 14 value	R/W
42076 (3 reg)	46054	Level 15 value	R/W
42079 (3 reg)	46056	Level 16 value	R/W
42082 (3 reg)	46058	Level 17 value	R/W
42085 (3 reg)	46060	Level 18 value	R/W
42088 (3 reg)	46062	Level 19 value	R/W
42091 (3 reg)	46064	Level 20 value	R/W
42094 (3 reg)	46066	Level 21 value	R/W
42097 (3 reg)	46068	Level 22 value	R/W
42100 (3 reg)	46070	Level 23 value	R/W
42103 (3 reg)	46072	Level 24 value	R/W

Data type: Integer	Data type: float (2 reg./value)	Explanation	R/W
42106 (3 reg)	46074	Level 25 value	R/W
42109 (3 reg)	46076	Level 26 value	R/W
42112 (3 reg)	46078	Level 27 value	R/W
42115 (3 reg)	46080	Level 28 value	R/W
42118 (3 reg)	46082	Level 29 value	R/W
42121 (3 reg)	46084	Level 30 value	R/W
42124 (3 reg)	46086	Level 31 value	R/W
42127 (3 reg)	46088	Level 32 value	R/W
42130 (3 reg)	46090	Setpoint 1 value	R/W
42133 (3 reg)	46092	Setpoint 2 value	R/W
42136 (3 reg)	46094	Setpoint 3 value	R/W
42139 (3 reg)	46096	Setpoint 4 value	R/W
42142 (3 reg)	46098	Setpoint 5 value	R/W
42145 (3 reg)	46100	Setpoint 6 value	R/W
42148 (3 reg)	46102	Setpoint 7 value	R/W
42151 (3 reg)	46104	Setpoint 8 value	R/W
42154 (3 reg)	46106	Setpoint 9 value	R/W
42157 (3 reg)	46108	Setpoint 10 value	R/W
42160 (3 reg)	46110	Setpoint 11 value	R/W
42163 (3 reg)	46112	Setpoint 12 value	R/W
42166 (3 reg)	46114	Setpoint 13 value	R/W
42169 (3 reg)	46116	Setpoint 14 value	R/W
42172 (3 reg)	46118	Setpoint 15 value	R/W
42175 (3 reg)	46120	Setpoint 16 value	R/W

*/ The read value is always 'zero'.

Important:

'Net weight', 'Gross weight' and 'Flow rate' registers for a scale are only valid when corresponding 'Scale X error code' register equals 0. Therefore it's recommended to read the 'Instrument error' register together with these registers.

Instrument type

This register holds the type of the instrument. For G4 Multi Channel Weighing Instrument this value is 4001.

Standard program major and minor version

This registers holds the major and minor version for a standard program.

Special program major and minor version

This registers holds the major and minor version for a special program. Both values are 0 for a standard program.

Serial number

This register holds the serial number of the instrument. The value 991000 means 99-1000. This can be used by the master to be sure that an instrument with a specific serial number is used for a special process.

Command error

This register holds the error code when a command has been sent to the instrument. A command that gives a 03 or 07 as exception will have an error code with a better description of the problem in this register. Normally this register should contain '00' which means no error. Error codes 0 to 255 are valid in this register.

Instrument state

This register contains the state of the G4 instrument unit.

Code	Description
00	'Starting up' state. The instrument is starting up after a reset or power on.
01	'Wait for start' state. The instrument is waiting for a start command to go in process.
02	'Warming up state' The parameter 'Warm up time' is set to a value other than zero, and the instrument is waiting for the warming up time to pass.
03	'Normal' state. There are no parameter errors in the system. Note: Weight errors still indicate normal state.
04	'Error' state. An error has been detected during start up of the instrument.
05	'Fatal error' state. An error has been detected during start up of the instrument. It's not possible to enter any other state from here.

Instrument error

This register holds the overall error code for the instrument.
Normally this register should contain '00' which means no error.

Instrument status

This register holds the overall status for the instrument

Bits set to 1 in this register have the following meaning:

Bit no	Function	Comment
0	Remote operation	'1' = On '0' = Off
1	Program reset	<p>The bit is set each time the program starts, and it indicates that volatile data is lost.</p> <p>The bit is reset as Instrument status is read, over serial communication (Modbus RTU) or over Ethernet (Modbus TCP), for the first time after reset/power-up. Note that the reply contains the set bit if it was set.</p> <p>Reading Instrument Status via Fieldbus interface will <u>not</u> reset this bit. To reset this bit with fieldbus interface a specific reset command must be used.</p> <p>Care must be taken if more than one interface is used to communicate with the instrument and the Program reset bit is to be used.</p>
2		
3		
4		
5		
6		
7		
8		
9		
10		
11		
12		
13		
14		
15		

Note: If this register (bits) is read as float value, see description of Data representation.

Scale X: Error code

This register holds the error code for a scale.
Normally this register should contain '000' which means no error.
Error codes 000 to 255 are valid in this register.

Scale X: Status

Status for a scale.

Bits set to 1 in this register have the following meaning:

Bit no	Function	Comment
0	Net weight > INT size	The net weight in 'scaled integer' format does not fit in one register. (See description of data representation.)
1	Gross weight > INT size	The gross weight in 'scaled integer' format does not fit in one register. (See description of data representation.)
2	Flow rate > INT size	The flow rate in 'scaled integer' format does not fit in one register. (See description of data representation.)
3	Good zero (disp. weight)	
4	Good zero Gross	
5	Good zero Net	
6	Net Mode	'1' = Net mode '0' = Gross mode
7	Motion	Unstable weight
8		
9		
10		
11	Flow rate display	Flow rate is shown in the display.
12	Net weight > 6 digits	The net weight value is out of precision and should normally not be used.
13	Gross weight > 6 digits	The gross weight value is out of precision and should normally not be used.
14		
15		

Note: If this register (bits) is read as float value, see description of Data representation.

Scale X: Gross weight

This register holds the gross weight for a scale. The weight should **not** be read alone because the status and error codes are stored in other registers. The weight is only valid when the register 'Scale X:Error code' equals 00.

Scale X: Net weight

This register holds the net weight for a scale. The weight should **not** be read alone because the status and error codes are stored in other registers. The weight is only valid when the register 'Scale X:Error code' equals 00.

Scale X: Flow rate

This register holds the flow rate for a scale. The flow rate should **not** be read alone because the status and error codes are stored in other registers. The flow rate is only valid when the register 'Scale X:Error code' equals 00.

Scale X: Input signal (mV/V)

This register holds the current input signal in mV/V for a scale. This register could be used for fault finding in the system.

Analog output value 1, 2, 3, 4

These registers hold the values sent to the analog outputs. The registers can be used for fault finding in the system.

Note: The value is rounded to 3 decimals.

Status of inputs 11-18, 21-28

Bits set to 1 in this register have the following meaning:

Bit no	Function	Bit no	Function
0	Digital input 11 activated.	8	Digital input 21 activated.
1	Digital input 12 activated.	9	Digital input 22 activated.
2	Digital input 13 activated.	10	Digital input 23 activated.
3	Digital input 14 activated.	11	Digital input 24 activated.
4	Digital input 15 activated.	12	Digital input 25 activated.
5	Digital input 16 activated.	13	Digital input 26 activated.
6	Digital input 17 activated.	14	Digital input 27 activated.
7	Digital input 18 activated.	15	Digital input 28 activated.

Note: If this register (bits) is read as float value, see description of Data representation.

Status of inputs 31-38, 41-48

Bits set to 1 in this register have the following meaning:

Bit no	Function	Bit no	Function
0	Digital input 31 activated.	8	Digital input 41 activated.
1	Digital input 32 activated.	9	Digital input 42 activated.
2	Digital input 33 activated.	10	Digital input 43 activated.
3	Digital input 34 activated.	11	Digital input 44 activated.
4	Digital input 35 activated.	12	Digital input 45 activated.
5	Digital input 36 activated.	13	Digital input 46 activated.
6	Digital input 37 activated.	14	Digital input 47 activated.
7	Digital input 38 activated.	15	Digital input 48 activated.

Note: If this register (bits) is read as float value, see description of Data representation.

Status of inputs 51-58, 61-68

Bits set to 1 in this register have the following meaning:

Bit no	Function	Bit no	Function
0	Digital input 51 activated.	8	Digital input 61 activated.
1	Digital input 52 activated.	9	Digital input 62 activated.
2	Digital input 53 activated.	10	Digital input 63 activated.
3	Digital input 54 activated.	11	Digital input 64 activated.
4	Digital input 55 activated.	12	Digital input 65 activated.
5	Digital input 56 activated.	13	Digital input 66 activated.
6	Digital input 57 activated.	14	Digital input 67 activated.
7	Digital input 58 activated.	15	Digital input 68 activated.

Note: If this register (bits) is read as float value, see description of Data representation.

Status of outputs 11-18, 21-28

Bits set to 1 in this register have the following meaning:

Bit no	Function	Bit no	Function
0	Digital output 11 activated.	8	Digital output 21 activated.
1	Digital output 12 activated.	9	Digital output 22 activated.
2	Digital output 13 activated.	10	Digital output 23 activated.
3	Digital output 14 activated.	11	Digital output 24 activated.
4	Digital output 15 activated.	12	Digital output 25 activated.
5	Digital output 16 activated.	13	Digital output 26 activated.
6	Digital output 17 activated.	14	Digital output 27 activated.
7	Digital output 18 activated.	15	Digital output 28 activated

Note: If this register (bits) is read as float value, see description of Data representation.

Status of outputs 31-38, 41-48

Bits set to 1 in this register have the following meaning:

Bit no	Function	Bit no	Function
0	Digital output 31 activated.	8	Digital output 41 activated.
1	Digital output 32 activated.	9	Digital output 42 activated.
2	Digital output 33 activated.	10	Digital output 43 activated.
3	Digital output 34 activated.	11	Digital output 44 activated.
4	Digital output 35 activated.	12	Digital output 45 activated.
5	Digital output 36 activated.	13	Digital output 46 activated.
6	Digital output 37 activated.	14	Digital output 47 activated.
7	Digital output 38 activated.	15	Digital output 48 activated

Note: If this register (bits) is read as float value, see description of Data representation.

Status of outputs 51-58, 61-68

Bits set to 1 in this register have the following meaning:

Bit no	Function	Bit no	Function
0	Digital output 51 activated.	8	Digital output 61 activated.
1	Digital output 52 activated.	9	Digital output 62 activated.
2	Digital output 53 activated.	10	Digital output 63 activated.
3	Digital output 54 activated.	11	Digital output 64 activated.
4	Digital output 55 activated.	12	Digital output 65 activated.
5	Digital output 56 activated.	13	Digital output 66 activated.
6	Digital output 57 activated.	14	Digital output 67 activated.
7	Digital output 58 activated.	15	Digital output 68 activated

Note: If this register (bits) is read as float value, see description of Data representation.

Level status 1-16

Bits set to 1 in this register have the following meaning:

Bit no	Function	Comment
0	Above level 1	The weight is above Level 1.
1	Above level 2	The weight is above Level 2.
2	Above level 3	The weight is above Level 3.
3	Above level 4	The weight is above Level 4.
4	Above level 5	The weight is above Level 5.
5	Above level 6	The weight is above Level 6.
6	Above level 7	The weight is above Level 7.
7	Above level 8	The weight is above Level 8.
8	Above level 9	The weight is above Level 9.
9	Above level 10	The weight is above Level 10.
10	Above level 11	The weight is above Level 11.
11	Above level 12	The weight is above Level 12.
12	Above level 13	The weight is above Level 13.
13	Above level 14	The weight is above Level 14.
14	Above level 15	The weight is above Level 15.
15	Above level 16	The weight is above Level 16.

Note: If this register (bits) is read as float value, see description of Data representation.

Level status 17-32

Bits set to 1 in this register have the following meaning:

Bit no	Function	Comment
0	Above level 17	The weight is above Level 17.
1	Above level 18	The weight is above Level 18.
2	Above level 19	The weight is above Level 19.
3	Above level 20	The weight is above Level 20.
4	Above level 21	The weight is above Level 21.
5	Above level 22	The weight is above Level 22.
6	Above level 23	The weight is above Level 23.
7	Above level 24	The weight is above Level 24.
8	Above level 25	The weight is above Level 25.
9	Above level 26	The weight is above Level 26.
10	Above level 27	The weight is above Level 27.
11	Above level 28	The weight is above Level 28.
12	Above level 29	The weight is above Level 29.
13	Above level 30	The weight is above Level 30.
14	Above level 31	The weight is above Level 31.
15	Above level 32	The weight is above Level 32.

Note: If this register (bits) is read as float value, see description of Data representation.

Setpoint status 1-8

Bits set to 1 in this register have the following meaning:

Bit no	Function	Comment
0	Setpoint 1 activated	See description for setpoint function.
1	Setpoint 1 cycle done	See description for setpoint function.
2	Setpoint 2 activated	See description for setpoint function.
3	Setpoint 2 cycle done	See description for setpoint function.
4	Setpoint 3 activated	See description for setpoint function.
5	Setpoint 3 cycle done	See description for setpoint function.
6	Setpoint 4 activated	See description for setpoint function.
7	Setpoint 4 cycle done	See description for setpoint function.
8	Setpoint 5 activated	See description for setpoint function.
9	Setpoint 5 cycle done	See description for setpoint function.
10	Setpoint 6 activated	See description for setpoint function.
11	Setpoint 6 cycle done	See description for setpoint function.
12	Setpoint 7 activated	See description for setpoint function.
13	Setpoint 7 cycle done	See description for setpoint function.
14	Setpoint 8 activated	See description for setpoint function.
15	Setpoint 8 cycle done	See description for setpoint function.

Note: If this register (bits) is read as float value, see description of Data representation.

Setpoint status 9-16

Bits set to 1 in this register have the following meaning:

Bit no	Function	Comment
0	Setpoint 9 activated	See description for setpoint function.
1	Setpoint 9 cycle done	See description for setpoint function.
2	Setpoint 10 activated	See description for setpoint function.
3	Setpoint 10 cycle done	See description for setpoint function.
4	Setpoint 11 activated	See description for setpoint function.
5	Setpoint 11 cycle done	See description for setpoint function.
6	Setpoint 12 activated	See description for setpoint function.
7	Setpoint 12 cycle done	See description for setpoint function.
8	Setpoint 13 activated	See description for setpoint function.
9	Setpoint 13 cycle done	See description for setpoint function.
10	Setpoint 14 activated	See description for setpoint function.
11	Setpoint 14 cycle done	See description for setpoint function.
12	Setpoint 15 activated	See description for setpoint function.
13	Setpoint 15 cycle done	See description for setpoint function.
14	Setpoint 16 activated	See description for setpoint function.
15	Setpoint 16 cycle done	See description for setpoint function.

Note: If this register (bits) is read as float value, see description of Data representation.

Clock

These registers are used to read the time and date from the instrument.

Command register

As this register is read, the answer will always contain only zeros.

There are a number of actions that can be activated in the instrument. The value of this register (when different from zero) will activate one of these actions, as described in below.

When an action can not be performed for some reason (wrong state etc.) an exception is given as reply. When an exception with code 03 or 07 is received the command error register could be read to get a better error explanation.

Cmd	Action activated in instrument	Description
0	No action	
1	Start operation	When the instrument is in 'Wait for start state', this command can be used to start up the instrument.
2	Enter Remote operation	This command disables the keys on the instrument. This means that an external computer is controlling the instrument or the instrument is controlled using digital inputs.
3	Exit Remote operation	This command enables the keys and leaves the remote operation.
10	Scale 1: Auto tare	
11	Scale 1: Set to zero	Used to set the gross weight to zero.
12	Scale 1: Select gross mode	
13	Scale 1: Select net mode	
14	Scale 1: Weight display	Show weight on the display.
15	Scale 1: Flow rate display	Show flow rate on the display.
20	Scale 2: Auto tare	
21	Scale 2: Set to zero	Used to set the gross weight to zero.
22	Scale 2: Select gross mode	
23	Scale 2: Select net mode	
24	Scale 2: Weight display	Show weight on the display.
25	Scale 2: Flow rate display	Show flow rate on the display.
30	Scale 3: Auto tare	
31	Scale 3: Set to zero	Used to set the gross weight to zero.
32	Scale 3: Select gross mode	

Cmd	Action activated in instrument	Description
33	Scale 3: Select net mode	
34	Scale 3: Weight display	Show weight on the display.
35	Scale 3: Flow rate display	Show flow rate on the display.
40	Scale 4: Auto tare	
41	Scale 4: Set to zero	Used to set the gross weight to zero.
42	Scale 4: Select gross mode	
43	Scale 4: Select net mode	
44	Scale 4: Weight display	Show weight on the display.
45	Scale 4: Flow rate display	Show flow rate on the display.
50	Scale 5: Auto tare	
51	Scale 5: Set to zero	Used to set the gross weight to zero.
52	Scale 5: Select gross mode	
53	Scale 5: Select net mode	
54	Scale 5: Weight display	Show weight on the display.
55	Scale 5: Flow rate display	Show flow rate on the display.
60	Scale 6: Auto tare	
61	Scale 6: Set to zero	Used to set the gross weight to zero.
62	Scale 6: Select gross mode	
63	Scale 6: Select net mode	
64	Scale 6: Weight display	Show weight on the display.
65	Scale 6: Flow rate display	Show flow rate on the display.
70	Scale 7: Auto tare	
71	Scale 7: Set to zero	Used to set the gross weight to zero.
72	Scale 7: Select gross mode	
73	Scale 7: Select net mode	
74	Scale 7: Weight display	Show weight on the display.
75	Scale 7: Flow rate display	Show flow rate on the display.
80	Scale 8: Auto tare	
81	Scale 8: Set to zero	Used to set the gross weight to zero.

Cmd	Action activated in instrument	Description
82	Scale 8: Select gross mode	
83	Scale 8: Select net mode	
84	Scale 8: Weight display	Show weight on the display.
85	Scale 8: Flow rate display	Show flow rate on the display.
100	Activate setpoint 1	See description of setpoint function.
101	Deactivate setpoint 1	See description of setpoint function.
102	Activate setpoint 2	See description of setpoint function.
103	Deactivate setpoint 2	See description of setpoint function.
104	Activate setpoint 3	See description of setpoint function.
105	Deactivate setpoint 3	See description of setpoint function.
106	Activate setpoint 4	See description of setpoint function.
107	Deactivate setpoint 4	See description of setpoint function.
108	Activate setpoint 5	See description of setpoint function.
109	Deactivate setpoint 5	See description of setpoint function.
110	Activate setpoint 6	See description of setpoint function.
111	Deactivate setpoint 6	See description of setpoint function.
112	Activate setpoint 7	See description of setpoint function.
113	Deactivate setpoint 7	See description of setpoint function.
114	Activate setpoint 8	See description of setpoint function.
115	Deactivate setpoint 8	See description of setpoint function.
116	Activate setpoint 9	See description of setpoint function.
117	Deactivate setpoint 9	See description of setpoint function.
118	Activate setpoint 10	See description of setpoint function.
119	Deactivate setpoint 10	See description of setpoint function.
120	Activate setpoint 11	See description of setpoint function.
121	Deactivate setpoint 11	See description of setpoint function.
122	Activate setpoint 12	See description of setpoint function.
123	Deactivate setpoint 12	See description of setpoint function.
124	Activate setpoint 13	See description of setpoint function.
125	Deactivate setpoint 13	See description of setpoint function.
126	Activate setpoint 14	See description of setpoint function.
127	Deactivate setpoint 14	See description of setpoint function.
128	Activate setpoint 15	See description of setpoint function.

Cmd	Action activated in instrument	Description
129	Deactivate setpoint 15	See description of setpoint function.
130	Activate setpoint 16	See description of setpoint function.
131	Deactivate setpoint 16	See description of setpoint function.
132	Activate setpoint 1-16	See description of setpoint function.
133	Deactivate setpoint 1-16	See description of setpoint function.

Scale X: Preset tare value

This registers is used to read and write a new preset tare for a scale.

Level X value

These registers are used to read and write levels that are supervised by the instrument.

Setpoint X value

The registers are used to read and write setpoints. See description of setpoint function.

I/O bits (Coils)

The instrument has a number of I/O bits that the master can write to using Modbus function 05 or 15.

Each of these I/O bits are linked to a command in the instrument, which is described previously in this manual.

Set the I/O bit with the same number as the command that should be executed.

The action is activated if the master sets the I/O bit to 'ON'.

If the master sets the I/O bit to 'OFF', this is accepted, but no action is activated.

All I/O bits are WRITE ONLY. This means the master cannot read the I/O bits but only write to them.

Note: If the master tries to write to more than one I/O bit (Modbus function 15) the instrument will act on the lowest I/O bit number only.

Data representation

Data sent to and from the instrument uses 16 bit holding registers (40XXX) and can use different formats for flexibility.

Integer

Unsigned integer (1 modbus register)

Values stored in one modbus register as an unsigned integer (16 bit number without decimals).

Scaled integer (2 modbus registers + 1 modbus register = 3 modbus registers)

Values stored in a special 3 register format. The first two registers are used as a 32 bit long integer value (with sign) and the third register is holding the number of decimals in the value.

Example: 12345678 (32 bit number) in the two first registers and 3 in the third register give the value: 12345.678.

Register	Hex	Decimal	Description
1	00BC	188	The 16 most significant bits in the value.
2	614E	24910	The 16 least significant bits in the value.
3	0003	3	The number of decimals.

Calculations in decimal numbers:

First multiply the most significant register with 2^{16} (65536) and add the least significant register to the value.

$$188 * 2^{16} + 24910 = 12345678$$

Now divide the number to get the right number of decimals. The decimal register was set to 3 in this example, which gives the value $10^3 = 1000$ to divide with.

$$12345678 / 1000 = 12345.678$$

Note: If you want to read weight or flow rate values and your PLC system can't handle 32 bit values, the second register can be used as a 16 bit register with the number of decimals that is indicated in the third register. This will limit the value range to -32768 to +32767. Flags in Status register for corresponding scale indicates when the weights are bigger than a 16 bit integer. These flags must be checked to be sure that the weight or flow value fits in just one register.

Float values

The type of float values used in the communication is selected in the set-up for the different communication interfaces.

Values stored as standard IEEE 32 bit float values. Each value has two registers assigned to it. To read/write a float value an even number of Modbus registers, starting at an even address, must be read/written each time. The float values are stored in two different register orders.

Some devices may transfer the values with the high order bits in the first register and the low order bits in the second register. Other devices may invert the register order.

Modicon float: For true Modicon PLC's.

Float: Many third party controllers that support Modicon protocol use the float format where all bytes are written out in order to one 32 bit register, as opposed to Modicon float which uses 2 consecutive 16 bit registers.

When float registers representing bits are read, the bits set are returned as a float value.

For example if bit 4 is set the value 16.0 is returned as a float value, and if both bit 0 and bit 4 are set the value 17.0 is returned as a float value.

To use the value it's a good choice to convert it to an unsigned integer where the bits can be compared.

Exception responses

When the master sends a query to a slave it expects a normal response (as described earlier). One of the following three events occurs after a query from the master.

1. Normal response.

The slave has received the query without communication error and can handle the query normally. The slave returns a normal response.

2. Communication error.

If the slave does not receive the query due to a communication error, or detects some communication error (parity error or checksum error), **no** response is returned. The master should process a time-out for the query.

3. Command error.

If the slave receives the query without any communication error, but cannot handle the query, e.g. if the command was not valid, the requested register number not valid or instrument in a mode where the command was not allowed, then the slave will return an exception response informing the master of the nature of the error.

The following exception codes are possible.

Code	Name	Description
01	Illegal function	Not a valid function code. Valid function codes are 01, 02, 03, 05, 06, 08, 15, 16.
02	Illegal data address	Not a valid data address. See 'Register description' for a list of allowed registers.
03	Illegal data value	Value in data query field not valid. To get a better explanation of the error, the 'command error' register could be read.
07	Negative acknowledgement	The instrument has received the query but cannot perform it. To get a better explanation of the error, the 'command error' register could be read.

Supported Modbus functions

Function	Description
01 Read Coil Status	Reads the state of discrete outputs (0X references, coils). Only implemented because some 'masters' use this function to initiate communication. Coil range: 1 – 16 (Max number of points to read: 16). Response: Zero (OFF) for all requested points.
02 Read Input Status	Reads the state of discrete inputs (1X references). This function is implemented only because some 'masters' use this function to initiate communication. Input range: 1 – 16 (Max number of points to read: 16). Response: Zero (OFF) for all requested points.
03 Read Holding Reg.	Reads the binary contents of holding registers (4X references). Max number of registers to read: 125
05 Force Single Coil	Forces a single coil (0X references) to either ON or OFF. This function is used to activate commands in the instrument.
06 Preset Single Reg.	Presets a value into a single holding register (4X references).
08 Diagnostics	This function can provide a series of different communication tests, depending on a sub function code. The instrument supports only sub function code 00, which is a 'loop-back' test. The same data as received will be sent back to the master. Max number of data bytes: 64
15 Force Multiple Coils	Forces each coil (0X references) in a sequence of coils to either ON or OFF. This function is used to activate commands in the instrument. Max. number of points: 16 (only the first is used).
16 Preset Multiple reg.	Presets values into a sequence of holding registers (4X references). Max number of registers to preset: 125

Note: No broadcast messages are allowed.

It is possible to send or fetch any number of registers (max 125) or I/O bits (max. 16).
If the master tries to read more registers than there are available, the instrument will send dummy values for those registers not available.

Fieldbus interface

The optional fieldbus interface is based on a network communication module from HMS Industrial Networks. Available fieldbusses are Profibus and DeviceNet. With setup parameters the fieldbus interface is configured for the specific needs of an installation. It is possible to setup address, baud rate (if applicable to the actual fieldbus type) and mapping of the memory area in the fieldbus module that is available to the network.

The mapping is divided in one base block for data from the master to the instrument, one base block for data to the master from the instrument and 0 – 12 (selected with a setup parameter) configurable data blocks. The base blocks are mandatory. The data blocks are configurable regarding the content and in some cases also format (floating-point or integer).

The registers mentioned below are Modbus registers as defined in section Communication – Modbus Protocol. Each Modbus register is two bytes wide. This section also describes commands.

The size of the base blocks is 16 bytes from master to instrument and 32 bytes from the instrument to the master. The base blocks contain Instrument Error and Instrument Status. Besides instrument error and status information are the base blocks used for general purpose reading and writing of data and also for issuing commands to the instrument.

The mapping in the master and the instrument must always correspond.

Setup of fieldbus communication

- Complete the set-up of fieldbus communication before connecting it to the network to avoid possible network failure due to mismatch in configuration between network and instrument.
- Select the fieldbus type used in the 'Hardware Configuration' menu.
Note that the instrument will be restarted after changes in the hardware setup.
- Select the appropriate device address for the instrument. Address is setup in menu 'Communication – Fieldbus'.
Note that the address range is depending on type of fieldbus.
- Select baudrate, if applicable, according to the used baudrate in the network. Some fieldbusses may support automatic baud rate setting. Use fixed baudrate setting if there are difficulties to connect to the network or if the network baudrate is known.
- Select the number of data blocks that is needed for the installation. It is possible to use only the "base block" mapping if there is room for all necessary data within the 12 consecutive modbus registers that are defined within the base block (data from the instrument). The starting address of the read area is settable.
- Configure the desired number of data blocks. Note that the data blocks may still be configured as 'Not In Use' in which case the data within the block will be undefined.
- Check that the configuration of the master is compatible with the actual configuration of the instrument.
- Connect to the network.

Data from the fieldbus (Outputs in the master)

General

This 16 bytes block is mandatory, i.e. it is always mapped to the fieldbus in the instrument.

Byte	Contents
00	Command
01	Number of registers to write
02	Start address, Read/Write <small>MSB</small>
03	Start address, Read/Write
04	Write register 1 <small>MSB</small>
05	Write register 1
06	Write register 2 <small>MSB</small>
07	Write register 2
08	Write register 3 <small>MSB</small>
09	Write register 3
10	Write register 4 <small>MSB</small>
11	Write register 4
12	Write register 5 <small>MSB</small>
13	Write register 5
14	Write register 6 <small>MSB</small>
15	Write register 6

Byte 0:

The command byte is used when setting the read window starting address, writing data to the instrument and to issue various scale related commands such as taring, zeroing etc.

Commands:

0	No action
250 (hex FA)	Change read window
251 (hex FB)	Write data
252 (hex FC)	Clear the Program reset bit in the Instrument Status register.

Plus commands according to the manual, section '6. Communication – Modbus protocol – Command register'.

Note that a new command is detected when the content of the command register is changed. If the same command is used more than once another command e.g. 0 must be used in between.

The response to a given command is the 'Command acknowledge' and the 'Command error' bytes that are described below in section 'Data to the fieldbus'.

Byte 1:

Used to define the number of registers to write.

Bytes 2 and 3:

Define from which register number to read or write.

Bytes 4 to 15:

Contains the data when writing to the instrument.

Data to the fieldbus (Inputs in the master)

General

Data to the fieldbus are divided into two categories, one is the mandatory “base block” which contain general data and the 12 modbus register used for reading from the instrument. The second part is the up to twelve configurable data blocks.

Byte	Contents
00	Instrument error <small>MSB</small>
01	Instrument error
02	Instrument Status <small>MSB</small>
03	Instrument Status
04	Command acknowledge
05	Command error
06	Start address, Read <small>MSB</small>
07	Start address, Read
08	Read register 1 <small>MSB</small>
09	Read register 1
10	Read register 2 <small>MSB</small>
11	Read register 2
12	Read register 3 <small>MSB</small>
13	Read register 3
14	Read register 4 <small>MSB</small>
15	Read register 4

Byte	Contents
16	Read register 5 <small>MSB</small>
17	Read register 5
18	Read register 6 <small>MSB</small>
19	Read register 6
20	Read register 7 <small>MSB</small>
21	Read register 7
22	Read register 8 <small>MSB</small>
23	Read register 8
24	Read register 9 <small>MSB</small>
25	Read register 9
26	Read register 10 <small>MSB</small>
27	Read register 10
28	Read register 11 <small>MSB</small>
29	Read register 11
30	Read register 12 <small>MSB</small>
31	Read register 12

The first 32 bytes of data from the instrument to the fieldbus are mandatory.

Bytes 0 and 1:

Contains the actual instrument error information (the value 0 means no error). See section '6. Communication – Modbus protocol – Instrument error'.

Bytes 2 and 3:

The actual status information for the instrument, see section '6. Communication – Modbus protocol – Instrument status'.

Byte 4:

The 'Command acknowledge'. It will be equal to the command number if the command was successfully executed. If the command failed byte 4 will have the value 240 (hex F0).

Byte 5:

The possible 'Command error' code. The error code is explained in section '7. Troubleshooting – Error codes'. This byte will be zero if a command is correctly executed.

Bytes 6 and 7:

These two bytes is the starting address of the reading area following in bytes 8 to 31. The address defines the first of the 12 consecutive modbus registers in the read area. See section '6. Communication – Modbus protocol' for details on modbus register address definitions.

Bytes 8 to 31:

These 24 bytes is the area used when the user wants to read any data that is accessible through modbus registers. The address (number) of the first register is defined in bytes 6 and 7 and the instrument will keep the 24 bytes (12 registers) updated.

Configurable data blocks

Byte	Contents
32	Start of data block 1
48	Start of data block 2
64	Start of data block 3
80	Start of data block 4
96	Start of data block 5
112	Start of data block 6
128	Start of data block 7
144	Start of data block 8
160	Start of data block 9
176	Start of data block 10
192	Start of data block 11
208	Start of data block 12

Data Blocks is used to transfer data from the instrument to the master. Up to 12 data blocks can be used. Each block consists of 16 bytes. The data blocks have fixed positions in memory, see list below.

Last byte is no. 223. A total of 224 bytes data can be mapped from the instrument to the master. Of the maximum 224 bytes are 32 bytes the mandatory base block.

Type of data blocks

- Gross Weight data, floating point or integer format
- Net Weight data, floating point or integer format
- Displayed Weight data, floating point or integer format
- Flow Rate data, floating point or integer format
- Input Signal (transducer mV/V) data, floating point or integer format
- Level status, floating point format
- Setpoint status, floating point format
- Input status, floating point format
- Output status, floating point format
- Input and output status, integer format
- Level and setpoint status, integer format
- Analog output value 1 to 4, floating point format
- Analog output value 1 and 2, integer format
- Analog output value 3 and 4, integer format

The offset in the left column, in the following descriptions of the data block types, is the starting byte number (see table above) for the actual data block number.

The Weight data blocks (floating-point and integer formats) below are a common description of the five different types that can be selected: Gross Weight, Net Weight, Disp. Weight, Flow Rate and Input Signal.

See section '6. Communication – Modbus protocol' for a description of the contents of the different data blocks and the integer and floating-point data formats.

Weight data block (Floating-point format)

Byte	Contents
Offset + 0	Scale x: Error code _{MSB}
Offset + 1	Scale x: Error code
Offset + 2	Scale x: Error code
Offset + 3	Scale x: Error code
Offset + 4	Scale x: Status _{MSB}
Offset + 5	Scale x: Status
Offset + 6	Scale x: Status
Offset + 7	Scale x: Status
Offset + 8	Scale x: Data _{MSB}
Offset + 9	Scale x: Data
Offset + 10	Scale x: Data
Offset + 11	Scale x: Data
Offset + 12	Not used
Offset + 13	Not used
Offset + 14	Not used
Offset + 15	Not used

Note: Scale Data can be (selected by parameter) Gross Weight, Net Weight, Displayed Weight, Flow Rate Value or Input Signal.

X is the selected (by parameter) scale number for the data block.

The table above describes the data block format if the parameter 'Data Block N Format' is set to 'Floating point' where 'N' stands for the index of the Data Block (1 – 12).

Weight data block (Integer format)

Byte	Content
Offset + 0	Scale x: Error code _{MSB}
Offset + 1	Scale x: Error code
Offset + 2	Scale x: Status _{MSB}
Offset + 3	Scale x: Status
Offset + 4	Scale x: Data, int _{MSB}
Offset + 5	Scale x: Data, int
Offset + 6	Scale x: Data, int
Offset + 7	Scale x: Data, int
Offset + 8	Scale x: Data, dec _{MSB}
Offset + 9	Scale x: Data, dec
Offset + 10	Not used
Offset + 11	Not used
Offset + 12	Not used
Offset + 13	Not used
Offset + 14	Not used
Offset + 15	Not used

Note: Scale Data can be (selected by parameter) Gross Weight, Net Weight, Displayed Weight, Flow Rate Value or Input Signal.

X is the selected (by parameter) scale number for the data block.

The table above describes the data block format if the parameter 'Data Block N Format' is set to 'Integer' where 'N' stands for the index of the Data Block (1 – 12).

Level status (Floating-point format)

Byte	Content
Offset + 0	Level status 1 – 16 _{MSB}
Offset + 1	Level status 1 – 16
Offset + 2	Level status 1 – 16
Offset + 3	Level status 1 – 16
Offset + 4	Level status 17 – 32 _{MSB}
Offset + 5	Level status 17 – 32
Offset + 6	Level status 17 – 32
Offset + 7	Level status 17 – 32
Offset + 8	Not used
Offset + 9	Not used
Offset + 10	Not used
Offset + 11	Not used
Offset + 12	Not used
Offset + 13	Not used
Offset + 14	Not used
Offset + 15	Not used

Setpoint status (Floating-point format)

Byte	Content
Offset + 0	Setpoint status 1 – 8 _{MSB}
Offset + 1	Setpoint status 1 – 8
Offset + 2	Setpoint status 1 – 8
Offset + 3	Setpoint status 1 – 8
Offset + 4	Setpoint status 9 – 16 _{MSB}
Offset + 5	Setpoint status 9 – 16
Offset + 6	Setpoint status 9 – 16
Offset + 7	Setpoint status 9 – 16
Offset + 8	Not used
Offset + 9	Not used
Offset + 10	Not used
Offset + 11	Not used
Offset + 12	Not used
Offset + 13	Not used
Offset + 14	Not used
Offset + 15	Not used

Input Status (Floating-point format)

Byte	Content
Offset + 0	Status of inputs 11 – 18, 21 – 28 <small>MSB</small>
Offset + 1	Status of inputs 11 – 18, 21 – 28
Offset + 2	Status of inputs 11 – 18, 21 – 28
Offset + 3	Status of inputs 11 – 18, 21 – 28
Offset + 4	Status of inputs 31 – 38, 41 – 48 <small>MSB</small>
Offset + 5	Status of inputs 31 – 38, 41 – 48
Offset + 6	Status of inputs 31 – 38, 41 – 48
Offset + 7	Status of inputs 31 – 38, 41 – 48
Offset + 8	Status of inputs 51 – 58, 61 – 68 <small>MSB</small>
Offset + 9	Status of inputs 51 – 58, 61 – 68
Offset + 10	Status of inputs 51 – 58, 61 – 68
Offset + 11	Status of inputs 51 – 58, 61 – 68
Offset + 12	Not used
Offset + 13	Not used
Offset + 14	Not used
Offset + 15	Not used

Output Status (Floating-point format)

Byte	Content
Offset + 0	Status of outputs 11 – 18, 21 – 28 <small>MSB</small>
Offset + 1	Status of outputs 11 – 18, 21 – 28
Offset + 2	Status of outputs 11 – 18, 21 – 28
Offset + 3	Status of outputs 11 – 18, 21 – 28
Offset + 4	Status of outputs 31 – 38, 41 – 48 <small>MSB</small>
Offset + 5	Status of outputs 31 – 38, 41 – 48
Offset + 6	Status of outputs 31 – 38, 41 – 48
Offset + 7	Status of outputs 31 – 38, 41 – 48
Offset + 8	Status of outputs 51 – 58, 61 – 68 <small>MSB</small>
Offset + 9	Status of outputs 51 – 58, 61 – 68
Offset + 10	Status of outputs 51 – 58, 61 – 68
Offset + 11	Status of outputs 51 – 58, 61 – 68
Offset + 12	Not used
Offset + 13	Not used
Offset + 14	Not used
Offset + 15	Not used

Inp./Outp Stat (Integer format)

Byte	Content
Offset + 0	Status of inputs 11 – 18, 21 – 28 <small>MSB</small>
Offset + 1	Status of inputs 11 – 18, 21 – 28
Offset + 2	Status of inputs 31 – 38, 41 – 48 <small>MSB</small>
Offset + 3	Status of inputs 31 – 38, 41 – 48
Offset + 4	Status of inputs 51 – 58, 61 – 68 <small>MSB</small>
Offset + 5	Status of inputs 51 – 58, 61 – 68
Offset + 6	Not used
Offset + 7	Not used
Offset + 8	Status of outputs 11 – 18, 21 – 28 <small>MSB</small>
Offset + 9	Status of outputs 11 – 18, 21 – 28
Offset + 10	Status of outputs 31 – 38, 41 – 48 <small>MSB</small>
Offset + 11	Status of outputs 31 – 38, 41 – 48
Offset + 12	Status of outputs 51 – 58, 61 – 68 <small>MSB</small>
Offset + 13	Status of outputs 51 – 58, 61 – 68
Offset + 14	Not used
Offset + 15	Not used

Lev./Setp. Stat (Integer format)

Byte	Content
Offset + 0	Level status 1 – 16 <small>MSB</small>
Offset + 1	Level status 1 – 16
Offset + 2	Level status 17 – 32 <small>MSB</small>
Offset + 3	Level status 17 – 32
Offset + 4	Setpoint status 1 – 8 <small>MSB</small>
Offset + 5	Setpoint status 1 – 8
Offset + 6	Setpoint status 9 – 16 <small>MSB</small>
Offset + 7	Setpoint status 9 – 16
Offset + 8	Not used
Offset + 9	Not used
Offset + 10	Not used
Offset + 11	Not used
Offset + 12	Not used
Offset + 13	Not used
Offset + 14	Not used
Offset + 15	Not used

AOUT1-4 Value (Floating-point format)

Byte	Content
Offset + 0	Analog output value 1 <small>MSB</small>
Offset + 1	Analog output value 1
Offset + 2	Analog output value 1
Offset + 3	Analog output value 1
Offset + 4	Analog output value 2 <small>MSB</small>
Offset + 5	Analog output value 2
Offset + 6	Analog output value 2
Offset + 7	Analog output value 2
Offset + 8	Analog output value 3 <small>MSB</small>
Offset + 9	Analog output value 3
Offset + 10	Analog output value 3
Offset + 11	Analog output value 3
Offset + 12	Analog output value 4 <small>MSB</small>
Offset + 13	Analog output value 4
Offset + 14	Analog output value 4
Offset + 15	Analog output value 4

AOUT1-2 Value (Integer format)

Byte	Content
Offset + 0	Analog output value 1, int <small>MSB</small>
Offset + 1	Analog output value 1, int
Offset + 2	Analog output value 1, int
Offset + 3	Analog output value 1, int
Offset + 4	Analog output value 1, dec <small>MSB</small>
Offset + 5	Analog output value 1, dec
Offset + 6	Not used
Offset + 7	Not used
Offset + 8	Analog output value 2, int <small>MSB</small>
Offset + 9	Analog output value 2, int
Offset + 10	Analog output value 2, int
Offset + 11	Analog output value 2, int
Offset + 12	Analog output value 2, dec <small>MSB</small>
Offset + 13	Analog output value 2, dec
Offset + 14	Not used
Offset + 15	Not used

AOUT3-4 Value (Integer format)

Byte	Content
Offset + 0	Analog output value 3, int _{MSB}
Offset + 1	Analog output value 3, int
Offset + 2	Analog output value 3, int
Offset + 3	Analog output value 3, int
Offset + 4	Analog output value 3, dec _{MSB}
Offset + 5	Analog output value 3, dec
Offset + 6	Not used
Offset + 7	Not used
Offset + 8	Analog output value 4, int _{MSB}
Offset + 9	Analog output value 4, int
Offset + 10	Analog output value 4, int
Offset + 11	Analog output value 4, int
Offset + 12	Analog output value 4, dec _{MSB}
Offset + 13	Analog output value 4, dec
Offset + 14	Not used
Offset + 15	Not used

Examples

Example 1: Setting 'Level 1 Value' to 123.5 (Writing to float value register).

1. Make sure that the previous command was not 251.
Set command byte (00) to 0 if previous command was 251.
2. Set number of registers (2) to write in byte 01.
3. Set start address (46026) in bytes 02 and 03.
See section '6 Communication – Modbus protocol – General registers'.
4. Set the following four bytes (04 – 07) to the value to write (123.5).
5. Enter the command (251) in byte 00.

Byte	Description	Dec	Hex
00	Command	251	FB
01	Number of registers to write	2	02
02 – 03	Start address	46026	B3 CA
04 – 07	Value to write in register 1 and 2	123.5	42 F7 00 00
08 – 15	Write registers 3 – 6.	—	—

Example 2: Setting 'Setpoint 14 value' to 123.5 (Writing to integer value register).

1. Make sure that the previous command was not 251.
Set command byte (00) to 0 if previous command was 251.
2. Set number of registers (3) to write in byte 01.
3. Set start address (42169) in bytes 02 and 03.
See section '6 Communication – Modbus protocol – General registers'.
4. Set the following four bytes (04 – 07) to the value to write 123.50,
i.e. 12350 and two decimals.
5. Set bytes 08 and 09 to number of decimals. In this example is 2 decimals used.
6. Enter the command (251) in byte 00.

Byte	Description	Dec	Hex
00	Command	251	FB
01	Number of registers to write	3	03
02 – 03	Start address	42169	A4 B9
04 – 07	Value to write in register 1 and 2	12350	00 00 30 3E
08 – 09	Value to write to register 3	2	00 02
10 – 15	Write registers 4 – 6.	—	—

Example 3: Set read window to read from Scale 4 floating point data (registers 44074 to 44085). Note that the number of registers read is always 12.

1. Make sure that the previous command was not 250.
Set command byte (00) to 0 if previous command was 250.
2. Set start address (44074) in bytes 02 and 03.
See section '6 Communication – Modbus protocol – General registers'.
3. Enter the command (250) in byte 00.

Byte	Description	Dec	Hex
00	Command	250	FA
01	Number of registers to write	—	—
02 – 03	Start address	44074	AC 2A
04 – 15	Write registers 1 – 6.	—	—

Example 4: Reset the 'Program reset' bit in 'Instrument status'.

1. Make sure that the previous command was not 252.
2. Enter the command (252) in byte 00.

Byte	Description	Dec	Hex
00	Command	252	FC
01	Number of registers to write	—	—
02 – 03	Start address	—	—
04 – 15	Write registers 1 – 6.	—	—

Example 5: Other commands like Taring, Zeroing etc.
See section '6 Communication – Modbus protocol – Command register' for a list of available commands.

1. Make sure that the previous command was not the desired command.
2. Enter the desired command in byte 00.

Byte	Description	Dec	Hex
00	Command	XXX	XX
01	Number of registers to write	—	—
02 – 03	Start address	—	—
04 – 15	Write registers 1 – 6.	—	—

Note that a dash in Dec. or Hex columns above indicates that the value is unimportant and not used for the function described.

7. Troubleshooting

General

During installation and maintenance of the G4 Instrument, the sub menu 'System Information' can be useful for solving possible I/O module and Ethernet related problems.

The instrument reports detected errors on the display. Error codes can also be read via communication.

When an error is detected for a scale, all digital outputs are set passive and the analog outputs are set to 0 V or 0 mA for outputs configured for that scale.

The output signal 'In Process' is set passive if an error is detected.

The optional fieldbus interface adapters have LED's for indication of status.

Error codes

This part provides explanations of the error codes.

Some errors are displayed on the instrument display, containing a description of the error and the error code.

Reading error codes is done by Modbus and by the optional Fieldbus. Error code registers are 'Instrument error', 'Command error' and 'Scale 1: Error code' to 'Scale 8: Error code' (see section '6 Communication').

The error codes are divided in four groups, depending on their origin:

- **Weight errors** occur when transducer signals or weight values go out of given ranges.
- **Start-up errors** occur only during start-up.
- **General errors** usually occur due to faulty entries from the front panel, alternatively invalid data or not allowed commands from the control unit.
- **Set-up errors** can only occur during instrument set-up.

On the following pages a summary of all error codes is given (note that code 000 always means 'no error').

Note that there are some error codes of internal type not described below. If an error code is displayed that is not listed below try restarting the instrument and if the error persists please contact your supplier.

Weight errors

The indication is either temporary or stays on until the cause is cured.

Error code	Explanation
000	No error. The instrument is in 'normal state' and no error is detected.
003	Instrument not in normal state. Weight is not valid.
004	Overload Overload means that the weight exceeds the highest allowed limit that is specified in the set-up parameters 'Overload check' and 'Overload limit'.
005	Over range Overrange means that the input signal from the transducer exceeds the operating range.
006	Underload Underload means that the weight is below the lowest allowed limit that is specified in the set-up parameters 'Overload check' and 'Overload limit'.
007	Under range Underrange means that the input signal from the transducer is below the operation range.
010	Excitation short-circuit Either a short-circuit in the excitation circuit or too many transducers connected. (A fault in a transducer or inside the instrument is also possible.) Check transducer connections. See section '2 Installation'.
011	Sense voltage error The sense voltage is out of range. Check transducer connections. See section '2 Installation'.
012	Transducer signal error The input signal is out of range, for example due to a faulty or missing transducer connection. (A fault in a transducer or inside the instrument is also possible.) Check transducer connections. See section '2 Installation'.
014	Invalid input signal Invalid input signal is reported while the instrument is waiting for sufficient conversion data to calculate a valid weight value. This indication is reported during power-up and after changing the HSWF / WFIN Update Rate settings since input value might be momentarily unreliable.
020, 191	Too many digits The actual weight value with the configured number of decimals is exceeding 6 digits.

Start-up errors

These error codes can only appear during start-up.

Error code	Explanation
081	<p>Set-up data error Indicates faulty set-up. Enter set-up mode, perform the necessary editing and save the new parameter settings or use the “Set Default values” function (Maintenance menu).</p>
082	<p>Set-up and installed I/O modules do not match The I/O-modules in the instrument doesn't correspond to the set-up. Correct the set-up or change modules.</p>
083	<p>Wrong type of Fieldbus Module The fieldbus module in the instrument doesn't correspond to the set-up. Correct the set-up or change module.</p>
084	<p>No Fieldbus Module There is no fieldbus module installed in the instrument but the set-up indicates there should be a fieldbus module. Correct the set-up or install the desired module.</p>
085	<p>Fieldbus Module Error There is some kind of error when configuring the fieldbus module. Check the status LED's on the module, check that the set-up corresponds to the network configuration, baud rate, addresses etc.</p>
090	<p>Failed to start the real time system Some error occurred when the real time dll was accessed during start up. Restart the instrument and if the error persists contact your supplier.</p>
091	<p>Database error An error occurred when the program tried to access the internal parameter database. To correct the problem first restart the instrument. If the error persists the database file can be deleted. The instrument will create a new database with default settings during restart. Upgrading the program (also reinstalling the present version) will also force a new database with default settings to be created. If the error still persists contact your supplier.</p>

General errors

These errors generally occur due to faulty entries from the front panel, alternatively invalid data or not allowed commands from the control unit.

Error code	Explanation
008	Scale not used The scale that is accessed via communication is not configured (used) in the instrument.
060 - 063	AOUT ch X termination error There is a termination error on an analog output channel. Too low impedance on a voltage output or too high impedance on a current output may cause this error.
070	I/O module communication error There is an internal error in the communication between the CPU module and one or more of the I/O modules. Restart the instrument and contact the supplier if the error persists.
071 - 074	I/O module reset There has been an internal reset within an I/O module. Restart the instrument and contact the supplier if the error persists.
100	Instrument in wrong state The transmitted command is not applicable to the present instrument mode.
101	Too high value! Value over allowed range. Compare with restrictions for the parameter.
102	Too low value! Value under allowed range. Compare with restrictions for the parameter.
103	Illegal start address. Illegal modbus start address, when writing data to the G4 instrument.
104	Illegal number of registers. Illegal number of modbus registers, when writing data to G4 instrument.
105	Faulty value Value not accepted when entering a parameter from front panel or illegal data in modbus registers, when writing data to the G4 instrument.
110	Unstable weight. Zero setting always requires a stable weight on the scale. If motion check is set to ON, also taring and printing of weight values require a stable weight on the scale. Consequently, if you try to transmit a command for zero setting, taring, or printing of weight value without awaiting a stable weight you will receive this error code.
111	Taring not allowed (negative gross weight). Taring is not allowed at negative gross weight if parameter 'Overload check' is set to Unipolar.
112	Instrument in net mode. Zero setting requires that the instrument is in gross mode. However, if you try to transmit a zero setting command while the scale is in net mode you'll receive this error code.

(Continued)

(Continued)

Error code	Explanation
113	<p>Outside zero setting limits. Adjustment of the zero setting during operation is only possible if the accumulated correction required is within -1% to +3% of the capacity set-up.</p> <p>Consequently, if you transmit a zero setting command while the required adjustment is outside allowed range you will receive this error code.</p>
114	<p>Setpoint(s) not in use. Activation/Deactivation of setpoint(s) cannot be done, as at least one of the setpoint sources is/are set to 'not in use'.</p>
116	<p>Net mode not allowed. Net weight cannot be shown when the tare value equals 0.</p>
117	<p>Flow display not allowed. Flow rate is not enabled for the actual scale.</p>
118	<p>Zero setting not allowed. Zero setting is not allowed when the calibration menu is displayed for the actual scale.</p>
240	<p>Fieldbus command error. Command error response on fieldbus connection. Indicates that the command sent to the G4 instrument via the fieldbus connection could not be executed.</p>
249	<p>Internal Timeout A timeout occurred when the program tried to access some internal resources. If this error occurs when a command is sent to the instrument, try the command again. Restart the instrument or contact the supplier if the error persists.</p>

Set-up errors

These errors occur only during instrument set-up from the front panel.

Certain errors depend on more than one set-up parameter and it is the operator's responsibility to locate and correct all faulty set-up parameters.

Error code	Explanation
151	<p>Weight error The weight is not valid during calibration. Check the live weight and input signal at the bottom of the display in calibration menus.</p>
152	<p>Unstable transducer signal used This is not an error but only a warning. The weight was not stable during calibration which might reduce the accuracy of the calibration. Wait a little longer and try again. If the problem persists, check the mechanical and electrical stability of the installation, check the live weight and input signal at the bottom of the display in calibration menus.</p>
153	<p>Capacity/Resolution > 6 digits The Capacity value has more than the permitted 6 digits. Select a combination of Resolution and Capacity that will result in max. 6 digits plus decimal point.</p>
155	<p>Illegal calibration direction All weights with corresponding mV/V values must be increasing for increasing calibration point number.</p>
156	<p>Calibration not finished (all calibration points not stored) This warning is given if the user is leaving the calibration menu when a dead weight calibration is started but not all calibration points are stored. The user will have the possibility to continue calibration, leave the menu and discard all calibration changes or leave the calibration menu and keep the calibration changes done so far. Note that leaving an unfinished calibration might give a faulty calibration of the scale.</p>
157	<p>The flow rate derivation time is changed by the instrument This is a warning that the flow rate derivation time has been changed automatically. It can be changed if Filter Update Rate is changed or if Auto Derivation Time is On also when changing parameters 'Flow Rate Unit' or 'Flow rate resolution'.</p>
190	<p>Zero track rate too high The zero-track rate is too high. Select a lower zero track rate.</p>
192	<p>Too high transducer signal in calibration point 2 The mV/V signal in calibration point two is too high (often due to a previous, strange data sheet calibration).</p>

(Continued)

(Continued)

Error code	Explanation
193	Too high transducer signal in calibration point 2 The mV/V signal in calibration point 2 is too high, due to strange data sheet calibration. The conversion factor, rated load etc. does not correspond to each other.
194	Illegal calibration direction All weights with corresponding mV/V values must be increasing for increasing calibration point number.
195	Illegal I/O module configuration The I/O-module set-up (Hardware Configuration menu) is not consistent with the allowed number of modules of the different types or the allowed combinations of modules.
196	Illegal scale number configuration Each scale number must only be used once. I.e. each measuring input must have a unique scale number. See menu 'Hardware Configuration'.

Declaration of Conformity

We Vishay Nobel AB
Box 423, S-691 27 KARLSKOGA
SWEDEN

declare under our sole responsibility that the products

Process control equipment consisting of following instruments:

G4 Desktop instrument, type G4-DT-FB-S1-S2-S3-S4-S5-S6-P.

G4 Harsh environment instrument, type G4-HE-FB-S1-S2-S3-S4-S5-S6-P.

G4 Panel mount instrument, type G4-PM-FB-S1-S2-S3-S4-S5-S6-P.

G4 Rail mount instrument, type G4-RM-FB-S1-S2-S3-V.

to which this declaration relates is in conformity with the
following standards or other normative documents.

The essential requirements in the EMC Directive 89/336/EEC
with amend. 92/31/EEC and 93/68/EEC.

EN 61 326:1997, EN 61 326 A3:2003

Low voltage directive 2006/95/EC : EN/IEC 61010-1:2001 ed.2
CE marked 2006

KARLSKOGA October. 15 2007

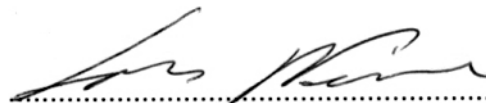

Lars Nilsson, Managing Director

Document no. 35160
Article no. 600 852 R2c
© Vishay Nobel AB, 2011-06-15
Subject to changes without notice.

Vishay Nobel AB
Box 423, SE-691 27 Karlskoga, Sweden
Phone +46 586 63000 · Fax +46 586 63099
pw.se@vishaypg.com
www.weighingsolutions.com

BLH
3 Edgewater Drive, Norwood, MA 02726, USA
Phone: 781-298-2200 Fax: 781-762-3988
pw.us@vishaypg.com
www.weighingsolutions.com