

Analogue Signal Transmitter AST 3IS

ATEX version. From ser. no. 2002-0001



Technical Manual

Contents

1. Introduction

General	1-1
Functions	1-2
Technical data	1-4

2. Installation

General	2-1
Electrical installation	2-1
Presentation panel	2-4

3. Set-up

General	3-1
Quick set-up	3-3
Normal set-up	3-7
Parameters	3-9

4. Calibration

General	4-1
Common calibration param.	4-2
Data sheet calibration	4-3
Dead weight calibration	4-4
Table calibration	4-4

5. Operation

General	5-1
Power supply	5-1
Power-up sequence	5-1
Display views in Oper. mode	5-2
Zero setting	5-3
Analogue output	5-3
Level supervision, relays	5-4

6. Communication

Communication interface	6-1
Line termination	6-1
Transmission principles	6-1
Modbus	6-2
Register descr. -Process param. ...	6-6
I/O bit (coil) description	6-11
Exception responses	6-12
Set-up registers	6-13
External display	6-14

7. Troubleshooting

General	7-1
Error codes	7-1

Appendices

Set-up list for AST 3IS	App. 1
Declaration of Conformity	App. 2
EC-Type Examination Certificate	App. 3

1. Introduction

General

AST 3IS is a high performance signal transmitter, designed for industrial measuring by means of strain gauge transducers.

Transducer excitation is included in the transmitter module and the low level analogue transducer signal is converted to a digital signal with very high resolution. By parameter controlled calculations, internal measurement values are produced for display at the front panel and for conversion to a current or voltage signal at the analogue output.

The measurement value can also be transmitted to an external display unit. Two channels for signal level supervision are included, with internal relays for the status indication.

By serial communication, a number of transmitter modules can be combined to form a network with one control unit in common.

All input and output signals are galvanically isolated from each other and the compact module is easily installed on a DIN-rail or a flat surface.

The transmitter module is designed and produced in accordance with European Parliament directive 94/9/EC, called the ATEX directive. Applies to CENELEC standards EN 50014 and EN 50020.

AST 3IS is an Associated apparatus of Isolator type.

A transducer, with safety marking including 1G (2G, 3G) and/or 1D (2D, 3D), placed in a hazardous area, can be connected directly to the AST 3IS, placed in the safe area.

The AST 3IS contains no user replaceable parts and, to comply with the certification, all repairs must be done by the manufacturer or an approved repairer.

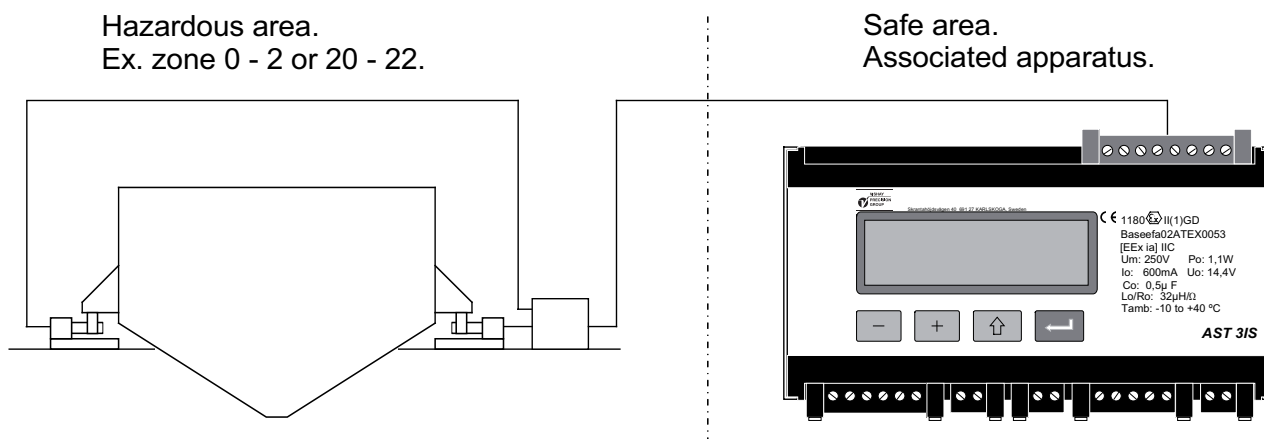

Figure 1 Direct cable connection between AST 3IS and transducers inside the hazardous area.

Functions

Measurement with strain gauge transducers. AST 3IS will measure transducer input voltage (sense) and output signal at the end of the integrated transducer cable. The cable can be lengthened with a shielded 6-wire cable where the transducer excitation from AST 3IS is provided over two separate wires (6-wire connection).

A/D conversion. The analogue signal-to-sense ratio from the transducer is converted to a digital value and filtered to give an internal transducer signal representation of the load on the transducer with a high resolution.

Calculation. Influenced by calibration data, the internal transducer signal is converted to a digital measurement value, the weight value, that can be presented at the local display window and at the control unit.

Analogue output. The calculated weight value is also converted into an analogue output signal, e.g. for presentation at the process control. Current or voltage output can be selected. The analogue output can also be forced to produce a selected, fixed current or voltage signal.

Error supervision. The error supervision is checking for electrical errors, invalid parameter values, and signals out of valid limits. As long as no error is detected, the signal 'In process' is present. If an error is detected an error message will be displayed, the signal 'In process' will be off, the relays will be deactivated and the analogue output signal will be set to 0 V or 0 mA.

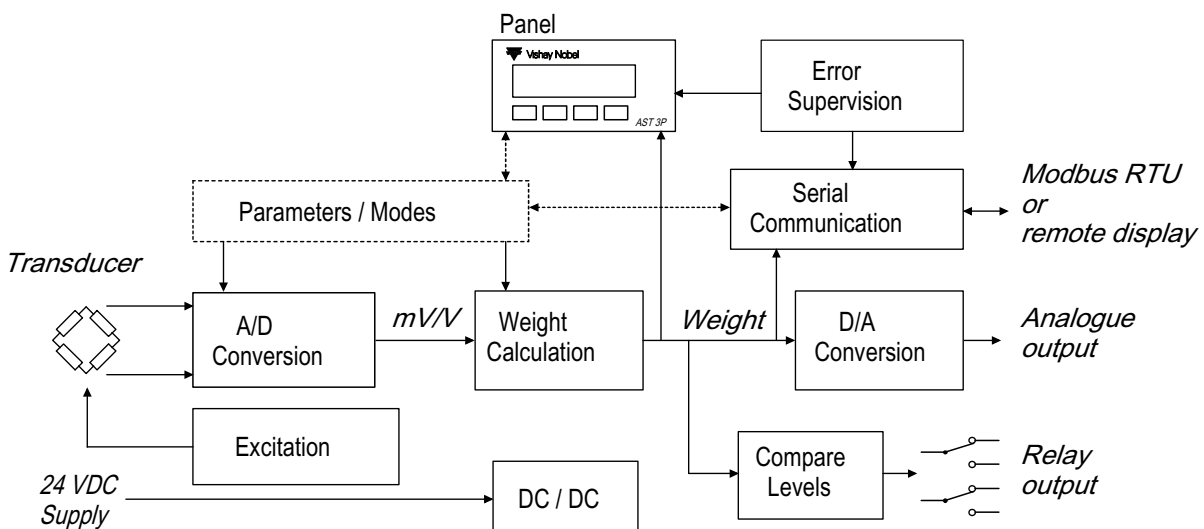

Figure 2 The Analogue Signal Transmitter AST 3IS converts analogue transducer signals into precise measurement signals for use in industrial processes.

Levels. Two level comparators in AST 3IS can be set to switch at defined levels for selected signals, reporting their status to the control unit.

In AST 3IS two switching relays are included. They can be set to indicate the status of the level comparators or the status of the signal 'In process'.

Serial communication. In AST 3IS the serial interface RS-485, on 2-wires or 4-wires, is used for communication with the control unit. Set-up and calibration parameters, weight value, level status, error status etc. is transmitted via the Modbus protocol. If the serial interface is not used for control unit communication, it can be used to transmit the weight value to external devices.

Instrument modes. At power-on the unit enters the Start-up mode, displaying its identity while internal tests are performed.

Then it may enter the Wait for start mode (selected by a parameter), waiting for a start command from the operator.

After completed start-up, the AST 3IS unit is normally working in Operating mode, continuously presenting the weight value (or other selected information).

If editing of set-up parameters should be performed, AST 3IS must be switched over to Set-up mode.

If an error is detected, AST 3IS will automatically switch over to Error mode, displaying an error message.

As AST 3IS is in Set-up mode or Error mode, normal instrument operation is disabled, the relays are deactivated, and the analogue output is set to zero.

Parameter setting. In AST 3IS, set-up parameters are used to control all operating functions. The parameter values can be entered as numerical values or selected from a list of alternatives.

For AST 3IS, the front panel keys and display window can be used for the parameter setting.

Setting of the parameter values can also be performed from a control unit.

Presentation. AST 3IS can present parameter values and measured or calculated signal values at a control unit and at the panel display.

The measurement value is also presented by the analogue output signal.

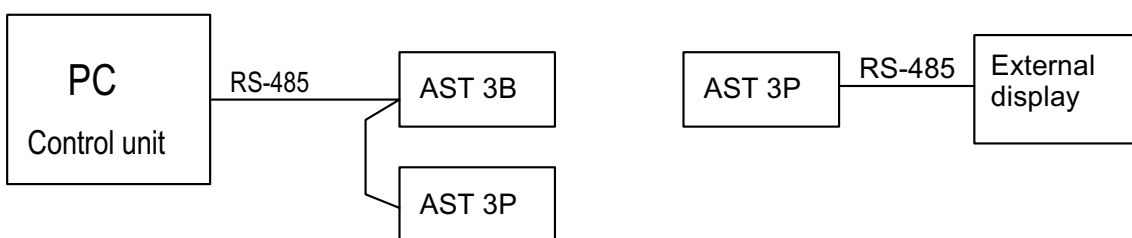

Figure 3 AST 3IS can utilise serial communication to carry out different operational tasks.

Technical data

Ex. safety description

EEx approval CENELEC

1180  II(1)GD

Baseefa02ATEX0053
[EEx ia] IIC

Production certification by Baseefa (2001), UK.

Product certificate by Baseefa (2001), UK.

Intrinsically safe associated apparatus, type isolator, to be placed in safe area and connected to intrinsically safe apparatus/devices marked 1G (2G, 3G) or/and 1D (2D, 3D) in explosive gas (G) or dust (D) atmosphere, or connected to intrinsically safe simple apparatus to EN50020 in explosive gas atmosphere.

See 'Ex. area connection' below.

Safety parameters

Tamb:	-10 to +40°C
Um:	250 V
Po:	1.10 W
Io:	600 mA
Uo:	14.4 V

Group	Capacitance	Inductance or L/R ratio *
II C **	0.5 µF	60 µH / 32 µH/Ω
II B	3.0 µF	180 µH / 130 µH/Ω
II A	12 µF	480 µH / 260 µH/Ω

*) It is sufficient that either the inductance or the inductance to resistance ratio of the load connected to the output terminals is smaller than the values in the table.

**) Cable example:

Cable FKAR-PG 4 x 2 x 0.5 mm² (40 Ω/km) with:
L/R <16 µH/Ω, Capacitance <1 nF/m.
480 m cable and four transducers (of <5 nF each) can be connected.

Ex. area connection.

Transducer input, isolated.

Transducers	Max 6, 350 ohms each. Total load >87 ohms.
Excitation	8.6 / 8.2 / 7.6 / 7.1 / 6.5 / 6.0 ±5 % VDC with 1 / 2 / 3 / 4 / 5 / 6 transducers connected.
Signal input	±3.3 mV/V.
Sense input	1.5–10 VDC.
A/D conversion	23 bits (8 300 000 counts). Patented design.

Safe area connections.

Power supply, isolated.

Supply voltage	24 VDC ±10 %, stabilised voltage. (Mains voltage for the power supply, max 250 VAC.)
Consumption	6 W.

Relay output, isolated.

Number of relays	2 (each with 1 switching group).
Relay load	Max 1 A, 30 V AC or DC.

Spark suppression required at inductive load.

Analogue output, isolated.

Bipolar voltage or current.

Voltage	0–10 VDC or +/-10 VDC over >500 ohms.
Current	0–20 mA, +/-20 mA, 4–20 mA, -12–20 mA in <500 ohms.
Filter	0.05–75 Hz, FIR, single pole.
Resolution	16 bits (65 000 counts).
Non-linearity	<0.01 % of range.
Zero drift	<0.005 % of range/°C.
Gain drift	<0.003 % of actual value/°C.

Serial output, isolated.

Can be used for control communication (Modbus) or external display.

Interface	RS-485, 2-wires or 4-wires.
Baud rate	Up to 115.2 kbaud.
Data format	Modbus RTU protocol for control unit communication.
Filter	0.05–75 Hz, FIR, single pole.
Non-linearity	<0.005 % of range.
Zero drift	<0.0002 % of 3.3 mV/V/°C.
Gain drift	<0.0015 % of actual value/°C.

Environmental.

Temperature range	-10 to +40 °C.
CE conformity	Industrial for process control.

Mechanical data.

Dimensions	75 x 149 x 110 mm (without connectors). At least 10 mm air gap between units. Rail mount, DIN 46 277/3 and DIN EN 50022 (35 mm).
Protection	IP 20.

Front panel.

Display	2 x 16 character LCD display.
Keys	4 keys for menu control and data entry.

Calibration.

Methods	Data sheet, Dead weight or Table.
---------	-----------------------------------

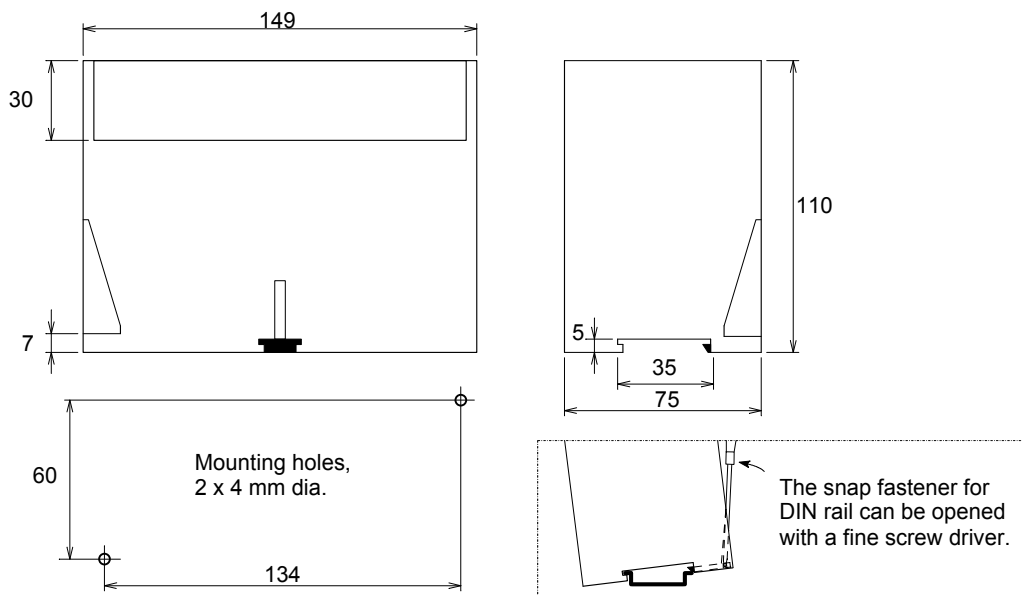

Figure 4. Mechanical dimensions for AST 3IS without electrical connections.



Figure 5. The Analogue Signal Transmitter AST 3IS.

2. Installation

General

Each signal transmitter module AST 3IS contains several circuit boards, built into a protective plastic housing. The module can be snap-mounted on a 35 mm wide DIN rail or attached on a flat surface by two 4 mm screws. Two groups of plug-in terminals for the cables are arranged on the module. The transducer cable is connected on one side of the module and all other cables on the opposite side.

Electrical installation

All electrical connections to the AST 3IS module, including possible connection to ground, are made via plug-in terminal blocks. Shielded cables are needed, except for the power supply, and the cables should be routed so that electromagnetic interference from power cables is avoided.

Input and output signals for AST 3IS are galvanically isolated from each other to facilitate connection to various external equipments. These equipments must not be connected to a voltage higher than 250 VAC.

The installation instructions in this manual are made for accordance with the ATEX directive. Ex. safety requirements due to national regulations must also be observed.

Cable connection is shown in the following diagrams.

Relay outputs

Terminals 9 – 11 and 12 – 14.

Observe the contact rating given in Technical data. Use shielded cable connected to ground, preferably by a ground terminal on the mounting rail.

When the relays are used, the operator has to observe the requirements of interference emission for electrical and electronic devices on the contact side and take appropriate measures, if necessary.

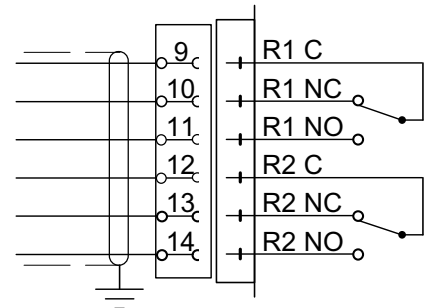

Digital inputs

Terminals 15, 16.

The instrument has two digital inputs.

The functions of these are ordered as an option.

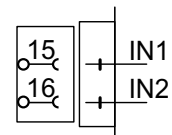

Power supply

Terminals 17, 18.

AST 3IS should be powered by 24 VDC, see requirements in Technical data.

Rail mounted power supplies, suitable for operation of one or several AST 3IS units, can be ordered from Nobel Weighing Systems.

For compliance with the CENELEC standard, the power supply input is protected by a transient fuse, not replaceable by the user. The fuse will blow by transients over 32 V. Consider the risk of transients from other equipment, connected to the same power supply.

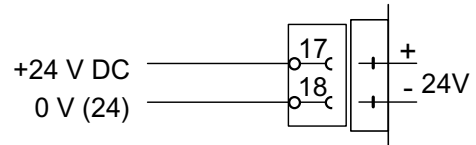

Serial communication

Terminals 19 – 23.

A serial port for RS-485, on 2-wire or 4-wire with common signal ground (COM), is used to connect AST 3IS to a control unit, or to transmit values to an external display unit.

At both ends, the transmission line must have terminating resistors of 120 ohms. For AST 3IS they should be mounted on separate terminals and be connected according to these diagrams. For a control unit or external display, refer to manufacturer instructions concerning line termination.

Shielded cable with twisted pairs should be used, the cable shield connected to ground, preferably by a ground terminal on the mounting rail.

When connecting several units to a transmission line, wires from two cables must be connected to the terminals at AST 3IS. Use cable ferrules crimped on the two wires to facilitate the connection.

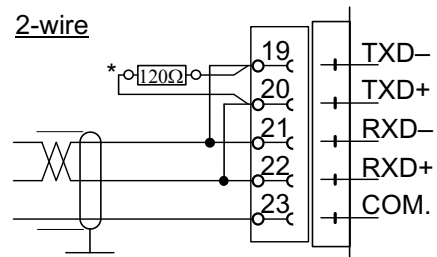

* Terminating resistor on separate terminals at the last unit on the line.

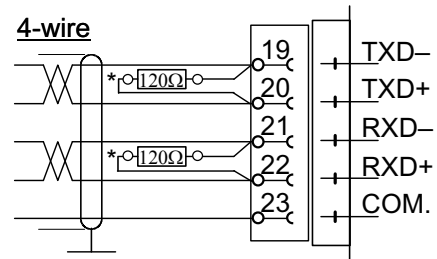

* Terminating resistor on separate terminals at the last unit on the line.

Analogue output

Terminals 24, 25.

Current output or voltage output for presentation of the measured value at the process control or at an external analogue instrument.

Connect the cable shield to ground, preferably to a ground terminal at the mounting rail.

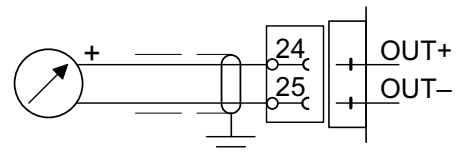

Transducer input

Terminals 1 – 7 (8).

Connection of transducers should be handled with great care to achieve good measuring data. The cable delivered with the transducer must not be shortened.

NOTE! Transducer cables must be routed at least 200 mm away from 230/380 V, 50/60 Hz power cables. By cables with other frequencies or high power, an even wider distance is preferable.

AST 3IS is designed for 4-wire connection or 6-wire connection of transducers.

4-wire connection should be used if the cable, delivered with the transducer, can be connected directly to the AST 3IS terminals. By 4-wire connection, excitation and sense must be interconnected as shown in the diagram below.

Connect the cable shield and terminal 5 to ground via the mounting rail.

6-wire connection should be used if the cable, delivered with the transducer must be lengthened, or if several transducers should be connected to one AST 3IS unit.

Connect the transducer cable(s) to a junction box, and use 6-wire connection between the junction box and AST 3IS. Connect terminal 5 to the cable shield, and connect all cable shields to ground only at the junction box.

In the diagram below connections are shown for the junction box SL-4 from Nobel Weighing Systems. Connection to ground is performed inside SL-4 by a wire from terminal J3 to the earth bolt.

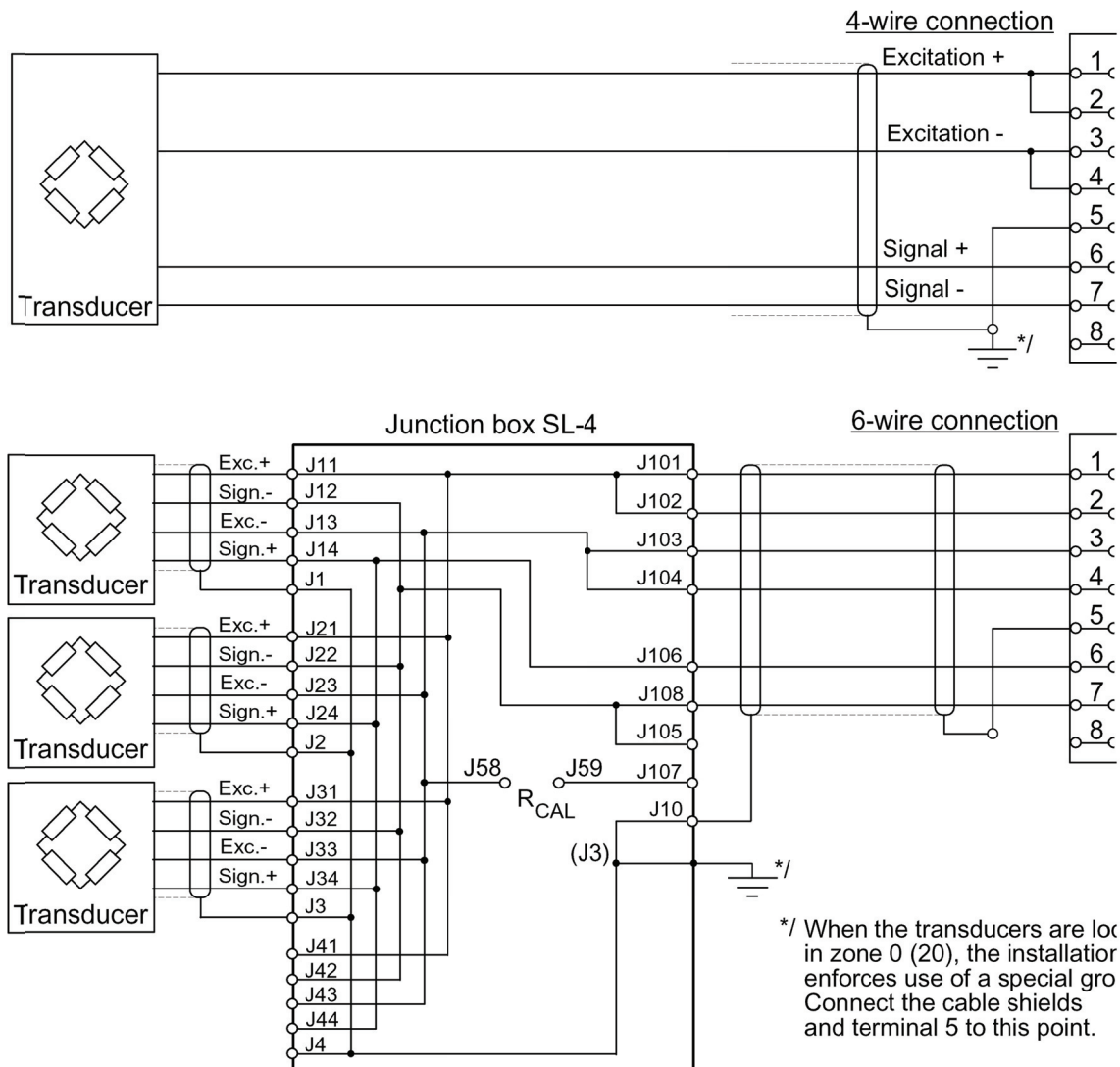

Presentation panel

The presentation panel of AST 3IS has a 2x16 character LCD display and four keys. In Operating mode the weight value is presented in one view, but other views may also be selected.





Set-up can be performed in two ways: the 'Quick set-up' with only a few vital parameters or the 'Normal set-up' with all the parameters available.

Error messages or parameter explanations can also be displayed.

The keys are used to select a parameter, to edit the parameter value, and to save the new value in the memory or to exit without saving the new value.























The key functions in the different modes are explained in the table below.

Key explanation

	Name	Function	
		In Operating mode:	In Set-up mode:
	ENTER	In view Zero setting: Set the value to zero. In all other views: No function.	In a 'Main menu': Go to the first parameter. Parameter viewing, <i>without</i> cursor: Make editing possible. Parameter editing, <i>with</i> cursor: Accept the digit at the cursor and go to next digit. <u>If ENTER is pressed for 2 seconds:</u> The displayed parameter value is activated. The cursor disappears.
	plus	Go to next view. See Figure 12. Together with ↑ for 2 sec.: Go to 'Normal set-up'. (Password may be required.)	In a 'Main menu': Go to next main menu. Parameter viewing, <i>without</i> cursor: Go to next parameter. Parameter editing, <i>with</i> cursor: Increment the digit at the cursor or Go to next alternative.
	minus	Go to previous view. See Figure 12.	In a 'Main menu': Go to previous main menu. Parameter viewing, <i>without</i> cursor: Go to previous parameter. Parameter editing, <i>with</i> cursor: Decrement the digit at the cursor or Go to previous alternative.
	ESCAPE	If pressed for 2 seconds: Go to 'Quick set-up'. (Password may be required.) If held while + is pressed for 2 seconds: Go to 'Normal set-up'. (Password may be required.)	In a 'Main menu': No function. Parameter viewing, <i>without</i> cursor: Go to the main menu. Parameter editing, <i>with</i> cursor: Interrupt the editing.

Example for how to use the keys:

As an AST 3IS is started for the first time it enters the Operating mode, displaying the Weight value. This example describes how to change 'Measurement unit' to pounds (lb) and Capacity to 1000 (lb), using the 'Quick set-up'. See figure 7.

- To leave Operating mode and enter 'Quick set-up', press  for 2 seconds.
- 'Main menu Quick set-up' is displayed.
Press  to get to the first parameter in the 'Quick set-up'.
- The first parameter, 'Language', is displayed.
Press  to get to 'Measurement unit'.
- For parameter 'Measurement unit', the default value 'kg' is displayed.
Press  to start editing.
A cursor makes the first letter on the lower line blinking.
- With a cursor on the lower line,  or  are used to step forwards or backwards through the list of alternatives.
Press  or  until 'lb' is displayed.
- To accept the displayed alternative, press  for 2 seconds.
The cursor disappears.
- Now, without cursor on the lower line, use  to get to parameter 'Capacity'.
The default value on the lower line, 500.0 lb, should be changed to 1000.0 lb.
- Press  to start editing.
The lower line will display '00500.0 lb' with a cursor at the first digit.
- The parameter value should be changed to '01000.0 lb'.
Press  once to accept the first digit and move to the second digit.
Press  or  to change the digit to '1'.
Press  to accept the value '1' and move to next digit.
Press  or  to change the digit from '5' to '0'. Now the value is correct.
Press  for 2 seconds, the cursor disappears and '1000.0 lb' is displayed.
- As the editing is ready, press  to get to 'Main menu Exit set-up'.
- Press . The sub menu 'Save changes? No Esc. Yes' will be displayed.
(Press  if you do not wish to exit from the set-up mode.)
- Answer by  (Yes) to save the new edited values.
Answer by  (No) to cancel the new values and return to previously saved values.

In both cases the set-up is finished and the module switches to Operating mode, displaying the Weight value.

3. Set-up

General

All operating functions in AST 3IS are controlled by permanently stored parameters, so the information will not be lost if the module is switched off.

At delivery the parameters are factory-set to default values, giving the module an initial standard function.

For AST 3IS modules connected to a control system, the parameter values can be edited by Modbus communication from a control unit in the system.

If a computer with Windows 95/NT4.0 is used, the deltaCOM program from Nobel Weighing Systems facilitates the editing of parameter values.

For an AST 3IS, all parameter values for the module can be edited by the front panel function keys.

When set-up from the control unit is in progress, local set-up of the AST 3IS is prevented and a message is displayed:

```
Remote set-up
Please wait!
```

When an AST 3IS is first taken into service, only a few parameters need to be edited to adapt the signal transmitter to the transducer and to obtain basic measuring function and correct values. These parameters are found in the 'Quick set-up' sequence, easily accessible from the AST 3IS front panel by activation of a single key, see figure 7 on next page.

When parameter values, not accessible in the 'Quick set-up' need to be edited, it is necessary to enter the 'Normal set-up' sequences.

These sequences contain all set-up parameters, divided in groups under a number of main menus. The 'Normal set-up' is started by activation of two keys simultaneously, see figure 8.

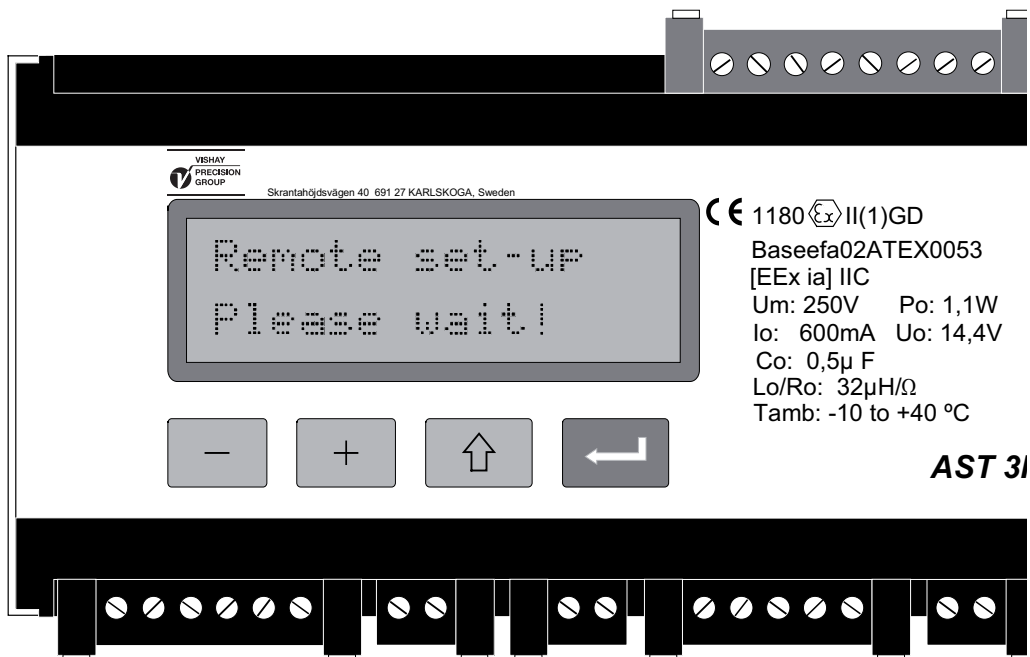

Figure 6. During set-up from a control computer, a message is given and the panel keys can not be used.

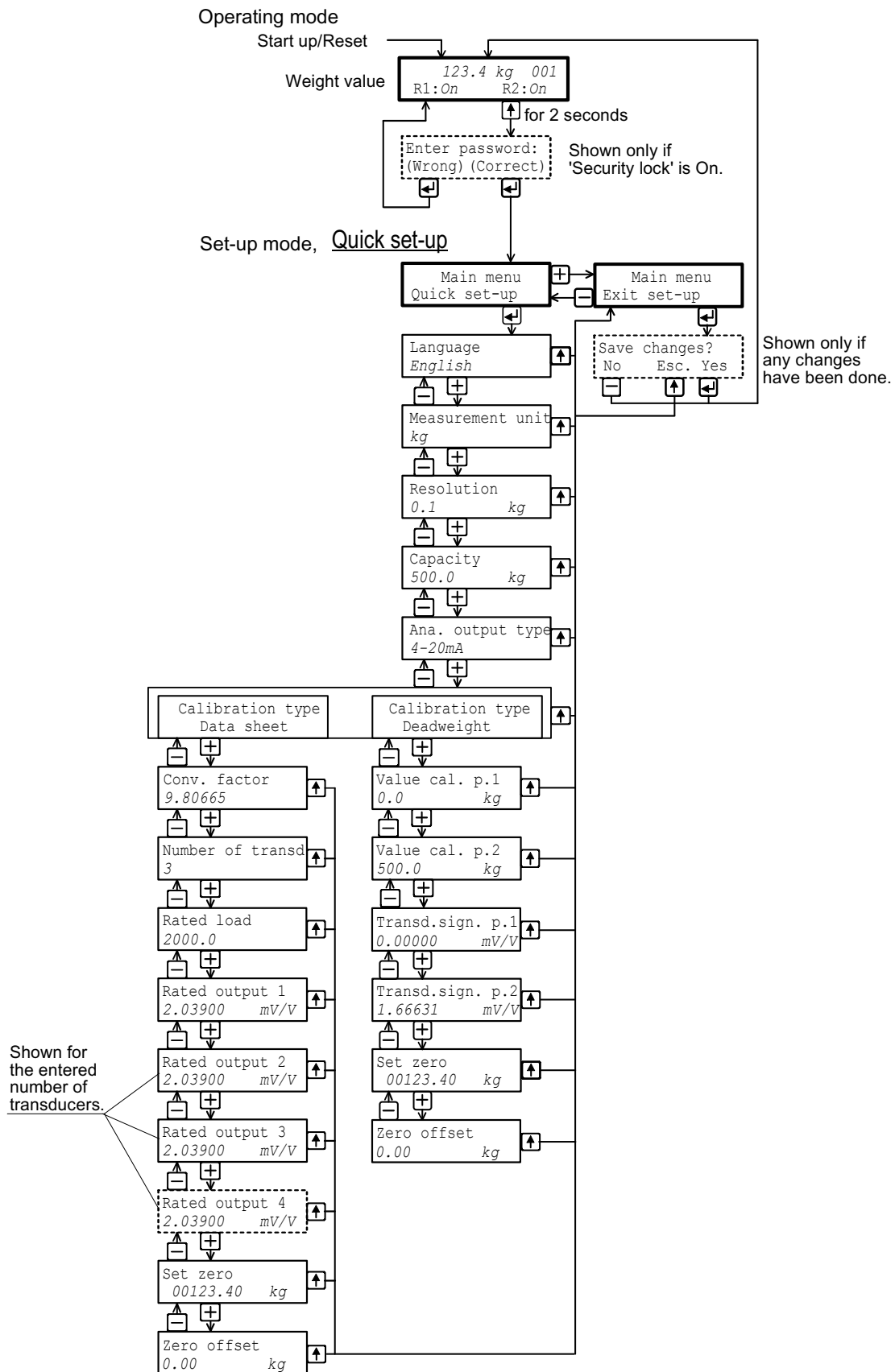



Figure 7. In the 'Quick set-up' only some basic parameters can be edited.

Quick set-up



In 'Quick set-up' for AST 3IS a few basic parameters can be edited. A separate publication, "AST 3 Operating instructions, Quick installation", gives a step-by-step instruction for the set-up operation. A brief instruction is given below. Parameter explanations are found on pages 3-4, 3-5 or in the complete parameter list on pages 3-10 to 3-22.

Enter 'Quick set-up'

Note! In Set-up mode all normal measuring operations are stopped!

Press  for 2 seconds. 'Main menu Quick set-up' will be displayed, possibly after entry of a correct password.



Show the parameters

When 'Main menu Quick set-up' is displayed, press  to attain the sequence of parameters. Parameter name and the actual parameter value are displayed together. Press the  key or the  key to step backwards or forwards in the parameter sequence, see figure 7.



Select a parameter to edit

Press  as the parameter is displayed. A blinking cursor appears to the left on the second line, and numerical parameter values get leading zeros. The cursor indicates that editing can be performed.

Edit a parameter value

For choice parameters the value is selected from a list of alternatives. As a cursor is blinking on the lower line, press the  (or ) key to find the correct alternative, then press  for 2 seconds to accept it, and the cursor disappears.

For numerical parameters each digit is edited separately.

The key  or  is used to edit the digit at the cursor. Then  is pressed to accept the digit value, and the cursor moves to next digit.

Repeat until a correct value with leading zeros is displayed, then press  for 2 seconds to accept it, and the cursor disappears.

If the value is out of range an error message will start flashing.



Any key can be pressed to remove the message, cancel the incorrect value, and make continued editing possible.

Press  to cancel the editing in progress and remove the cursor.

Calibration

Two calibration types are supported by 'Quick set-up': data sheet calibration and dead weight calibration. See section Calibration for more information about calibration types and parameters.

Exit 'Quick set-up'

See figure 7. First press  to get to 'Main menu Exit set-up', and then press . If nothing was edited, 'Quick set-up' is finished and view 'Weight value' is displayed. If any parameter has been edited, 'Save changes? No Esc. Yes' will be displayed. (Press  if you do not wish to exit from the set-up mode.)

If  (Yes) is pressed, all edited parameter values will be saved.

The new values should also be recorded in a set-up list. See appendix 1.

If  (No) is pressed, all edited parameter values will be cancelled.

All parameters resume the values they had before 'Quick set-up' was started. This finishes the 'Quick set-up' and the 'Weight value' view will be displayed.

Parameters in 'Quick set-up'

'Quick set-up' for AST 3IS includes parameters for setting of basic instrument properties and for calibration of the measuring equipment. For each parameter a short explanation and the range for the parameter value is given.

The parameters are also explained on pages 3-10 to 3-22.

'Language'

Defines the language, used for parameters and messages.

List of alternatives: Svenska, English, Deutsch, Français.

Default value: English.

'Measurement unit'

Selection of engineering unit for the measurement value.

List of alternatives:

NONE, g, kg, t, lb, N, kN, oz, psi, kPa, MPa, bar, l, lbf, kgf, PLI, N/m, kN/m, Nm, daN.

Default value: kg.

'Resolution'

Selection of decimal point position and resolution format for the measurement value.

All set-up parameters using the selected measurement unit will be written with the resolution selected here.

List of alternatives: 0.001, 0.002, 0.005, 0.01, 0.02, 0.05, 0.1, 0.2, 0.5, 1, 2, 5, 10, 20, 50.

Default value: 0.1.

'Capacity'

Nominal range of the analogue output, expressed in 'Measurement unit'.

An asterisk (*) on the upper line indicates that the range for the analogue output has been changed by parameters in 'Normal set-up'.

Possible values: from 0.5 to 999999.

Default value: 500.

'Ana. output type'

For the analogue output, several signal types can be selected: bipolar or monopolar current, bipolar or monopolar voltage.

List of alternatives: +/-20mA, -12-20mA, 0-20mA, 4-20mA, +/-10V, 0-10V.

Default value: 4-20mA.

'Calibration type'

Data sheet calibration is recommended as a preliminary calibration. With simple means it gives fairly good accuracy, so the equipment can be tested. Settings from an earlier dead weight calibration are lost if data sheet calibration is selected.

Dead weight calibration is the most accurate calibration type. Known weights are used as load on the equipment.

See section Calibration for further information on calibration types.

List of alternatives: Data sheet, Deadweight.

Default value: Data sheet.

'Conv. factor'

This parameter defines the conversion factor by which a value expressed in 'measurement unit', must be multiplied to be expressed in the transducer data sheet unit. Consequently the factor is 1 if measurement unit and data sheet unit are equal.

Default value can be used if 'measurement unit' is 'kg' and data sheet unit is 'Newton'.

Possible values: from 0.01 to 99.

Default value: 9.80665.

'Number of transd'

This parameter defines the total number of transducers and fixed support points for the load. If the number of support points is over 4, set the parameter value to 1.

Possible values: 1 to 4.

Default value: 3.

'Rated load'

This parameter defines the rated load for the transducer type, expressed in the unit of the transducer data sheet.

NOTE! If the data sheet value is for instance 5 kN, this parameter should be set to 5 000 (N).

If the number of support points is over 4 the parameter value should be: rated load multiplied by this number.

Possible values: from 1 to 999999.

Default value: 2000.00.

'Rated output 1' (2, 3, 4)

These parameters define the rated output for transducers and fixed support points. For transducers the rated output, in mV/V, is given in the data sheet. For fixed support points the rated output should be set to 0.00000 (mV/V).

If the number of support points is over 4 the parameter value should be: the sum of all rated output values, divided by the number of transducers.

Possible values: from 0 to +9.99999.

Default value: 2.03900.

'Value cal. p.1' (p.2)

These parameters define the known load on the scale for the two calibration points.

Calibration point 1 is the lower point, normally unloaded scale.

Calibration point 2 is the higher point, at least 2/3 of the nominal capacity.

Possible values: from -999999 to +999999.

Default values, Value cal. p.1: 0

Value cal. p.2: 500

'Transd.sign. p.1' (p.2)

These parameters give the transducer signals for the two calibration points.

The values can not be edited, make a note of them in the 'Set-up list' (Appendix 1) for possible use in a table set-up of a replacement instrument.

Possible values: from -9.99999 to +9.99999.

Default values, Transd.sign. p.1: 0.00000 mV/V

Transd.sign. p.2: 1.66631 mV/V

'Set zero'

Used in both calibration types for zeroing of the instrument.

The actual weight is displayed. Press , the weight value is set to zero.

Press  for 2 sec., the zeroing is accepted.

'Zero offset'

Displayed after zeroing for both calibration types.

Make a note of the parameter value in the 'Set-up list' (Appendix 1) for possible use in set-up of a replacement instrument.

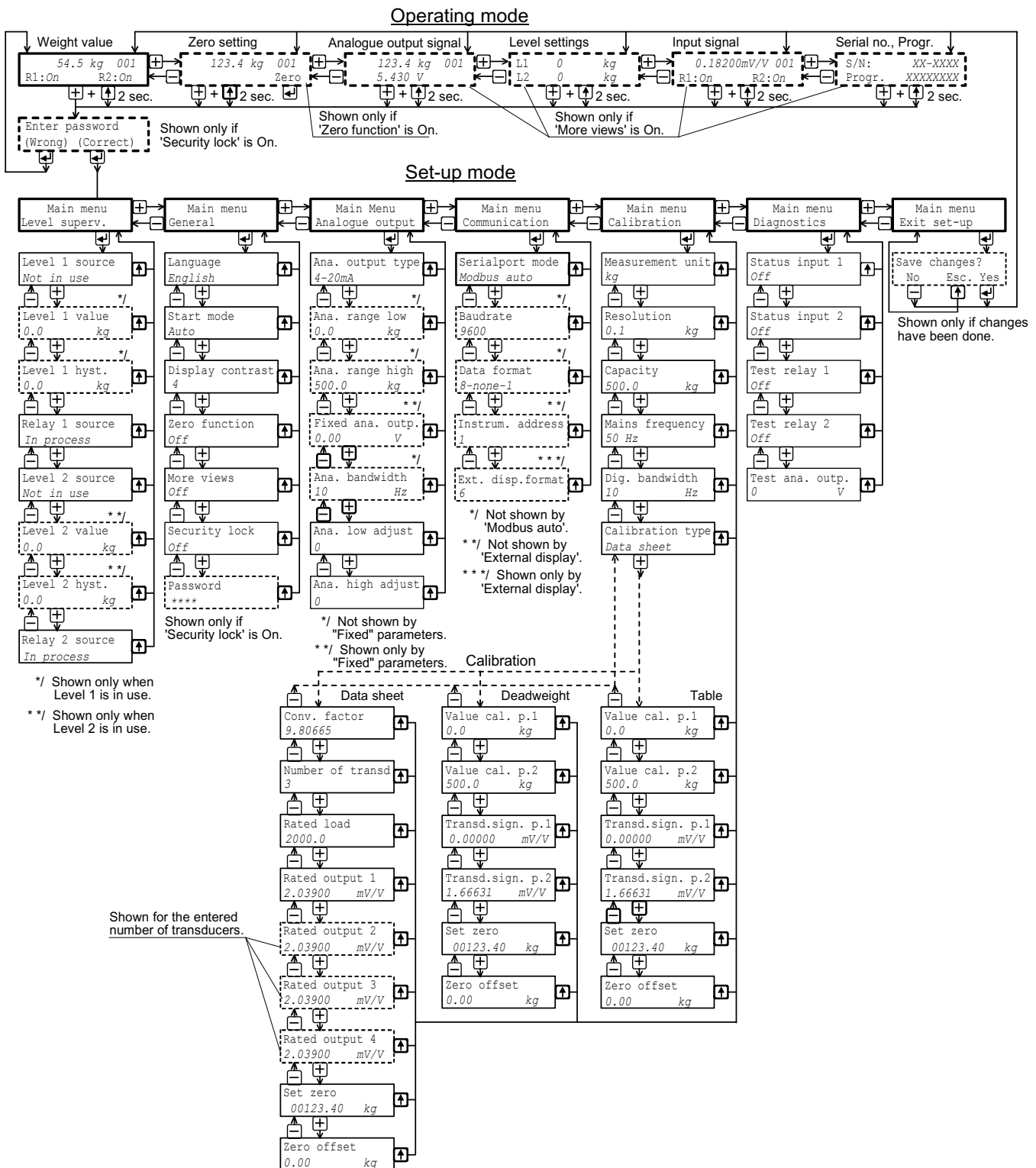

Figure 8. In 'Normal set-up' all adequate parameters are available for editing. Display of some parameters, indicated by intersected frames, depends on the setting for other parameters. The number of views available in Operating mode also depends on parameter settings. In this figure the parameter values are only examples.



Normal set-up

At delivery, the AST 3IS parameters have default values. During the set-up operation the parameters are set to appropriate values for the actual installation. These values are saved in the AST 3IS memory, and should also be recorded manually, for example in a set-up list, like the one in Appendix 1.

Set-up can be performed locally by the keys and the display on the front panel of AST 3IS. Set-up can also be performed from a connected control unit, preferably using the deltaCOM program from Nobel Weighing Systems.



Enter 'Normal set-up'

When AST 3IS is in Set-up mode, all normal measuring is stopped.

From any of the views in Operating mode, switch-over to 'Normal set-up' takes place when the keys  and  are activated simultaneously for 2 seconds. (Possibly after entry of a correct password).

Menu survey

All parameters in AST 3IS are accessible for editing by 'Normal set-up'. The parameters are divided in groups under the main menus, see figure 8 and 9. Each main menu with its parameters is also presented later in this section.

As shown in the figures, the keys  and  are used to step backwards and forwards in the sequence of main menus.

As a main menu is displayed, press  to enter in the group of parameters.

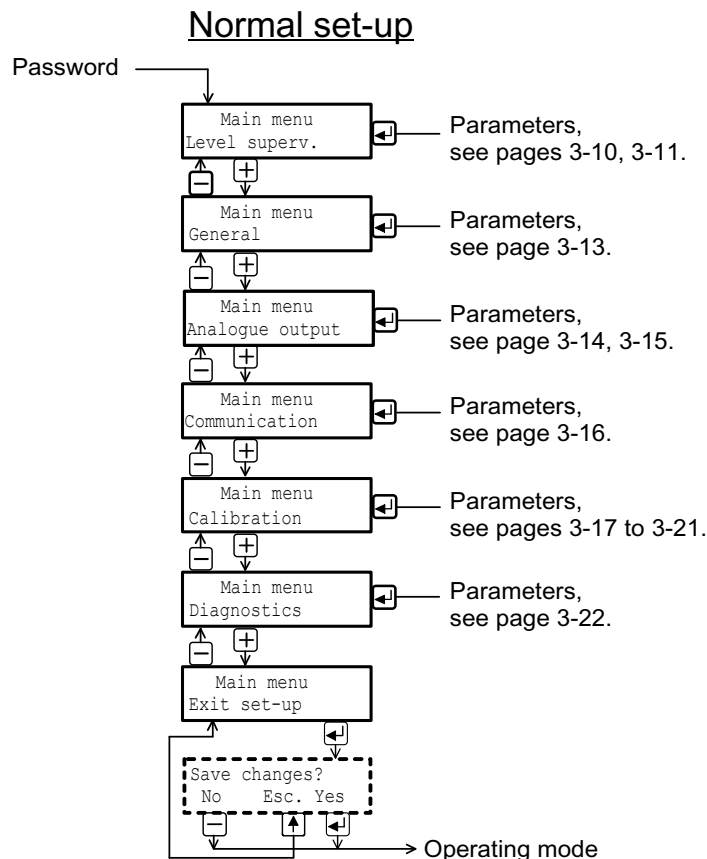

Figure 9. The set-up parameters are grouped under a number of main menus.

Main menus

'Level superv.'

AST 3IS has two identical channels for level supervision, called Level 1 and Level 2.

Parameters under 'Level superv.' are used to activate these channels and to select supervision of the transducer input signal or of the internal weight value.

Switching levels for the two channels are set individually to negative or positive values in a wide range. At the switching levels, a negative or positive hysteresis range can be added, giving a difference in switch level for increasing and decreasing signal.

Status indication for Level 1 and Level 2 are sent on the serial communication.

For AST 3IS, two internal relays can be set to indicate the status of Level 1 and Level 2, or to indicate when AST 3IS is in operation.

'General'

This main menu contains parameters for general use, like setting of a security lock for entry in set up mode, and a password for the lock, setting the type of instrument start up after power-on or reset, automatically or on operator command.

Selection of the language, the number of available views, and the character contrast in the display window is also set by parameters under 'General'.

'Analogue output'

The analogue output can present the measurement value as current or voltage. Several formats can be selected here. Scaling and adjustment of the output can also be done.

Parameters are included to set the analogue output to a fixed current or voltage level, independent of the internal weight value.

'Communication'

The instrument has a serial port for communication purposes. By parameters it can be set for control unit communication with suitable baudrate, data format, and instrument address, or for transmission of the measurement value to an external display unit.

'Calibration'

'Calibration' contains parameters for selection of engineering unit and resolution for the measurement value, setting of capacity for the instrument, and setting of filters to reduce mains frequency interference and to give a suitable bandwidth for the internal signal conversion.

Three calibration types are available:

Data sheet, where information about the used transducers and values from the data sheets are entered.

Dead weight, where the scale is loaded with known weights and the instrument is set to display corresponding weight values.

Table, where recorded values from a previous dead weight calibration of the installation is entered in a replacement instrument.

The calibration types also include parameters for zero setting and indication of the zero offset value.

'Diagnostics'



Parameters are available to test the digital inputs, the internal relays, and the analogue output.

'Exit set-up'

A sub menu gives the opportunity to save, or to cancel, all edited values before leaving the 'Normal set-up'.





Editing procedure, AST 3IS

To perform editing of a parameter in 'Normal set-up', first go to the main menu, containing the parameter and press ENTER (the  key).

Then use the key  or  to step forwards or backwards in the sequence to find the wanted parameter.





As the wanted set-up parameter is displayed, start the editing operation by . This will place a blinking cursor to the left on the lower line, and a numerical parameter value will get leading zeros. The cursor indicates that editing can be performed and that the panel key functions will be different.

See also the table on page 2-4.

Key	Function by parameter editing (with cursor)
	Increment the cursor digit, or Go to next alternative.
	Decrement the cursor digit, or Go to previous alternative.
 (short)	Accept the value of the cursor digit and go to next digit.
 (2 sec.)	Accept the actual parameter value and finish editing. If a value outside the range for a numeric parameter is entered, an error message is displayed. Then press any key to remove the message, cancel the value, and make continued editing possible.
	Cancel the edited value, and interrupt the editing.

As the parameter editing is finished, the set-up mode must be closed to make normal operation possible.

To close the set-up mode,

- press  to get to the main menu,
 - press  several times until 'Main menu Exit set-up' is displayed,
 - press , sub menu 'Save changes? No Esc. Yes' will be displayed.
- (Press  if you do not wish to exit from the set-up mode.)

Answer No () All edited values are cancelled and the parameters will resume their previous values. AST 3IS switches over to Operating mode, displaying the weight value.

Answer Yes () All edited values are saved in the module memory. AST 3IS switches over to Operating mode, displaying the weight value.

Parameters

On the following pages all set-up parameters, grouped under the main menus they belong to, are presented in the order they appear in the set-up sequences.

The first line indicates the parameter name and the Modbus addresses, used for set-up by serial communication. The parameters are saved in two different float formats and can therefore be read and written in two different registers.

For choice parameters an index in [] is given for each alternative. (These indices are used by set-up via Modbus.)

For numerical parameters a value range is given.

At the end of the table, the default value is given in < >.

To the right there is a short parameter explanation and, *in italic*, the results for the different alternatives.

[index]	Range/Alternative <default value>	Explanation and result of alternatives.
---------	--------------------------------------	--

'Main menu Level superv.'

Level 1 source Modbus: 41000 (46000)

[0]	Not in use	Turns Level 1 off or defines supervision of
[1]	Input sign. mV/V	transducer input signal or internal weight value.
[2]	Weight <Not in use>	Not in use: Supervision by Level 1 is turned off. Input sign. mV/V: The transducer input is supervised. Weight: The internal weight value is supervised.

Level 1 value Modbus: 41002 (46002)

Range: +/-999999 or +/-4.0000 Unit: Measurem. unit or mV/V <0>	Defines the switch level for Level 1. This parameter is set zero if the alternative for Level 1 source is changed. A suitable engineering unit, depending on the supervised signal, is automatically added.
--	--

Level 1 hyst. Modbus: 41004 (46004)

Range: +/-999999 or +/-4.0000 Unit: Measurem. unit or mV/V <0>	Defines the hysteresis range for Level 1. Positive value gives a hysteresis range above the switch level, negative value gives a range below the switch level. This parameter is set to zero if the alternative for Level 1 source is changed. A suitable engineering unit, depending on the supervised signal, is automatically added.
--	---

Relay 1 source Modbus: 41006 (46006)

[0]	Not in use	Defines the conditions for activation of Relay 1.
[1]	In process	Not in use: Relay 1 is not in use, deactivated.
[2]	Above level	In process: Relay 1 active as AST 3IS is in operation.
[3]	Below level <In process>	Above level: Relay 1 active as the supervised signal level is above 'Level 1 value'. Below level: Relay 1 active as the supervised signal level is below Level 1 value.

[index]	Range/Alternative <default value>	Explanation and result of alternatives.
---------	--------------------------------------	--

Level 2 source Modbus: 41008 (46008)

[0]	Not in use	Turns Level 2 off or defines supervision of transducer input signal or internal weight value. Not in use: Supervision by Level 2 is turned off. Input sign. mV/V: The transducer input is supervised. Weight: The internal weight value is supervised.
[1]	Input sign. mV/V	
[2]	Weight <Not in use>	

Level 2 value Modbus: 41010 (46010)

Range: +/-999999 or +/-4.0000	Defines the switch level for Level 2. This parameter is set to zero if the alternative for Level 2 source is changed.
Unit: Measurem. unit or mV/V	
<0>	

Level 2 hyst. Modbus: 41012 (46012)

Range: +/-999999 or +/-4.0000	Defines the hysteresis range for Level 2. Positive value gives a hysteresis range above the switch level, negative value a range below the switch level. This parameter is set to zero if the alternative for Level 2 source is changed. A suitable engineering unit, depending on the supervised signal, is automatically added.
Unit: Measurem. unit or mV/V	
<0>	

Relay 2 source Modbus: 41014 (46014)

[0]	Not in use	Defines the conditions for activation of Relay 2. Not in use: Relay 2 is not in use, deactivated. In process: Relay 2 active as AST 3IS is in Operation mode. Above level: Relay 2 active as the supervised signal level is above 'Level 2 value'. Below level: Relay 2 active as the supervised signal level is below 'Level 2 value'.
[1]	In process	
[2]	Above level	
[3]	Below level <In process>	

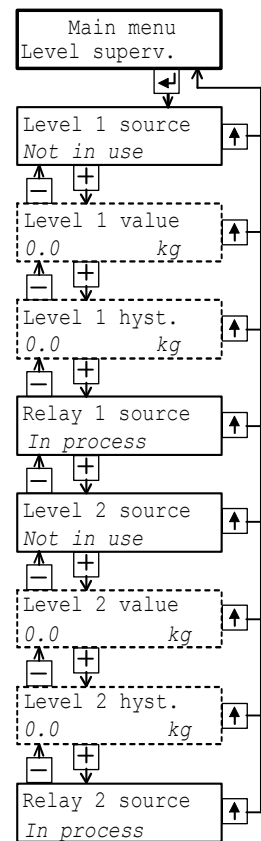

[index]	Range/Alternative <default value>	Explanation and result of alternatives.
---------	--------------------------------------	--

‘Main menu General’

Language Modbus: 41016 (46016)

[0]	Svenska	Defines the language to be used in parameters and messages.
[1]	English	
[2]	Deutsch	
[3]	Français	
	<English>	

Start mode Modbus: 41018 (46018)

[0]	Command	Defines the start mode after power-on or reset.
[1]	Auto	
	<Auto>	

Command: A ‘start operation’ command from control computer or panel key is required for start up.
Auto: Automatic start up.

Display contrast Modbus: 41020 (46020)

[0]	0	Defines the contrast for the text in the display window.
[1]	1	
[2]	2	Low values giving paler characters but better readability at slanted display.
[3]	3	
[4]	4	
[5]	5	High values giving sharper characters but reduced readability at slanted display.
[6]	6	
[7]	7	
	<4>	

Zero function Modbus: 41022 (46022)

[0]	Off	Off: The ‘Zero setting’ view in Operating mode is not available.
[1]	On	
	<Off>	On: ‘Zero setting’ is available.

More views Modbus: 41024 (46024)

[0]	Off	Off: The views ‘Analogue output signal’, ‘Level settings’, ‘Input signal’, and ‘Serial no., Progr.’ are not available in Operating mode.
[1]	On	
	<Off>	On: These views are available.

Security lock Modbus: 41026 (46026)

[0]	Off	Off: No security lock is activated.
[1]	On	
	<Off>	On: A security lock is activated, preventing unauthorised entry in Set-up mode.

Password Modbus: 41028 (46028)

Range:	0001 – 9999	Defines the valid password for the security lock. The code is represented by four asterisks, until editing is started.
	<1937>	

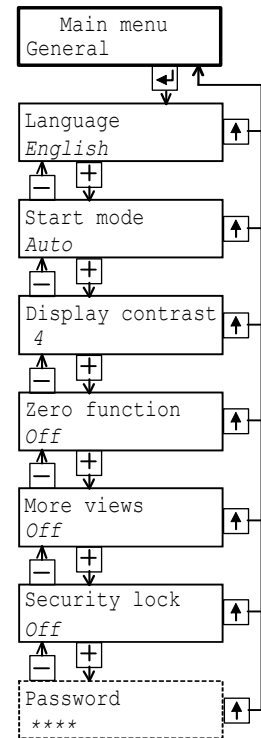

[index]	Range/Alternative <default value>	Explanation and result of alternatives.
---------	--------------------------------------	--

'Main menu Analogue output'

Ana. output type Modbus: 41030 (46030)

[0]	+/-20mA	Defines the type of signal, used to represent the weight value at the analogue output. +/-20mA, -12-20mA: bipolar current output, 0-20mA, 4-20mA: monopolar current output, +/-10V: bipolar voltage output, 0-10V: monopolar voltage output.
[1]	-12-20mA	
[2]	0-20mA	
[3]	4-20mA	
[4]	+/-10V	
[5]	0-10V	
[6]	Fixed+/-20mA	An output signal, independent of the weight value can also be selected. Fixed+/-20mA: fixed current output, Fixed+/-10V: fixed voltage output.
[7]	Fixed+/-10V <4-20mA>	

Ana. range low Modbus: 41032 (46032)

Range:	+/-999999	Defines the weight value that should give the lowest value (0 mA, 4 mA or 0 V) at the analogue output.
Unit:		
Measurem. unit	<0>	The value automatically changes to 0 if parameter 'Capacity' in 'Quick set-up' is edited.
		This parameter is not shown if a Fixed output type is selected in 'Ana. output type'.

Ana. range high Modbus: 41034 (46034)

Range:	+/-999999	Defines the weight value that should give the highest analogue output.
Unit:		
Measurem. unit	<500>	The value changes to the capacity value if parameter 'Capacity' in 'Quick set-up' is edited.
		This parameter is not shown if a Fixed output type is selected in 'Ana. output type'.

[index]	Range/Alternative <default value>	Explanation and result of alternatives.
---------	--------------------------------------	--

Fixed ana. outp. Modbus: 41036 (46036)

Range:
+/-22.00 or
+/-11.00
Unit: mA or V
<0>

Defines the fixed signal value at the analogue output.
The range and unit depends on the alternative for 'Ana. output type', and the value automatically changes to zero each time 'Ana. output type' is changed.
This parameter is shown only if a Fixed output type is selected in 'Ana. output type'.

Ana. bandwidth Modbus: 41038 (46038)

[0]	0.05	Hz	Defines the bandwidth for the analogue output.
[1]	0.1	Hz	Low bandwidth value improves suppression of unstable transducer signal, but also delays the response to fast transducer signal changes.
[2]	0.2	Hz	
[3]	0.5	Hz	High bandwidth value gives fast response to transducer signal changes, but reduces the accuracy of the analogue output.
[4]	1	Hz	
[5]	2	Hz	This parameter is not shown if a Fixed output type is selected in 'Ana. output type'.
[6]	5	Hz	
[7]	10	Hz	
[8]	20	Hz	
[9]	50	Hz	
[10]	75	Hz	
	<10	Hz>	

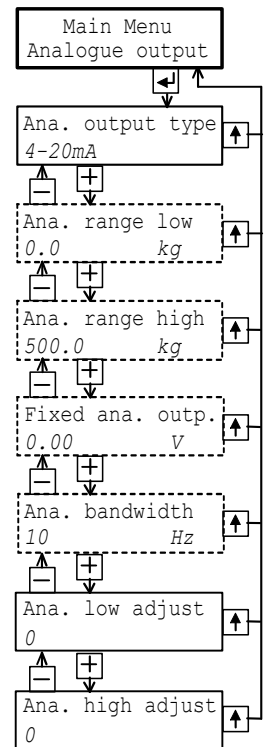

Ana. low adjust Modbus: 41040 (46040)

Range:
+/-999
<0>

As this parameter is edited, the analogue output is activated with the lowest output signal (0 mA, 4 mA or 0 V). The signal level can be adjusted to give wanted reading at the analogue instrument.
The adjustment range corresponds to about ±2 % of maximum analogue output.
The parameter value will be set to zero each time 'Ana. output type' is changed.

Ana. high adjust Modbus: 41042 (46042)

Range:
+/-999
<0>

As this parameter is edited, the analogue output is activated with the highest output signal (20 mA or 10 V). The signal level can be adjusted to give wanted reading at the analogue instrument.
The adjustment range corresponds to about ±2 % of maximum analogue output.
The parameter value will be set to zero each time 'Ana. output type' is changed.

[index]	Range/Alternative <default value>	Explanation and result of alternatives.
---------	--------------------------------------	--

'Main menu Communication'

Serialport mode Modbus: 41044 (46044)

[0]	Not in use	Defines the serial port use.
[1]	Modbus	Not in use: The serial port is not used.
[2]	Modbus auto	Modbus: The serial port is used for communication with a control unit.
[3]	External display <Modbus auto>	Modbus auto: The control unit baudrate (from 9600) and bit configuration (8-none-1, 8-even-1 or 8-odd-1) is autodetected and used by AST 3IS. External display: The serial port is used for transmission of the measurement value to an external display unit.

Baudrate Modbus: 41046 (46046)

[0]	300	Defines the baudrate for the serial communication.
[1]	600	
[2]	1200	The parameter must be set to the baudrate of the control computer, or
[3]	2400	to a baudrate suitable for the external display unit.
[4]	4800	
[5]	9600	
[6]	19200	This menu is not shown if 'Modbus auto' is selected in Serialport mode.
[7]	38400	
[8]	57600	
[9]	115200 <9600>	

Data format Modbus: 41048 (46048)

[0]	7-none-2	Defines the bit configuration for the serial communication.
[1]	7-even-1	
[2]	7-even-2	This parameter must be set to the same configuration as for the control computer, or to a configuration suitable for the external display unit.
[3]	7-odd-1	
[4]	7-odd-2	
[5]	8-none-1	
[6]	8-none-2	This menu is not shown if 'Modbus auto' is selected in Serialport mode.
[7]	8-even-1	
[8]	8-odd-1 <8-none-1>	

Instrum. address Modbus: 41050 (46050)

Range:	Defines the address for the AST 3IS-unit.
1 to 247	Shown only if 'Modbus' or 'Modbus auto' is selected in Serialport mode.
<1>	

Ext. disp.format Modbus: 41052 (46052)

[0]	4	Defines the number of digits on the external display unit.
[1]	5	
[2]	6	See section 6, Communication, for further information.
[3]	7	Shown only if 'External display' is selected in Serialport mode.
[4]	32 <6 >	

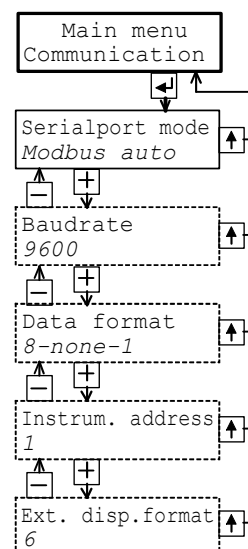

[index] Range/Alternative <default value> Explanation and result of alternatives.

‘Main menu Calibration’

Measurement unit Modbus: 41054 (46054)

[0]	NONE	Defines the engineering unit that should be used for the measurement value and for related set-up parameters .
[1]	g	
[2]	kg	
[3]	t	
[4]	lb	
[5]	N	
[6]	kN	
[7]	oz	
[8]	psi	
[9]	kPa	
[10]	MPa	
[11]	bar	
[12]	l	
[13]	lbf	
[14]	kgf	
[15]	PLI	
[16]	N/m	
[17]	kN/m	
[18]	Nm	
[19]	daN	
	<kg>	

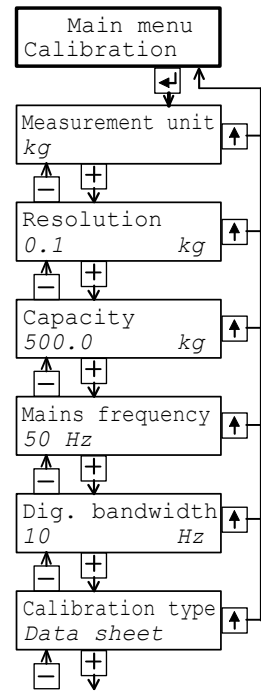

Resolution Modbus: 41056 (46056)

[0]	0.001	Defines the decimal point position and resolution format for the displayed value. All set-up parameters using the measurement unit will be written with the decimal point position selected here. If the last digits of the weight value are not stable, a more coarse resolution can be selected get a stable reading.
[1]	0.002	
[2]	0.005	
[3]	0.01	
[4]	0.02	
[5]	0.05	
[6]	0.1	
[7]	0.2	
[8]	0.5	
[9]	1	
[10]	2	
[11]	5	
[12]	10	
[13]	20	
[14]	50	
	<0.1>	

Capacity Modbus: 41058 (46058)

Range: 0.5 to 999999 <500> Defines the nominal range for the analogue output.

[index]	Range/Alternative <default value>	Explanation and result of alternatives.
Mains frequency Modbus: 41060 (46060)		
[0]	50 Hz	Defines a filter for suppression of mains frequency noise.
[1]	60 Hz	50 Hz: 50 Hz filter activated.
	<50 Hz>	60 Hz: 60 Hz filter activated.
Dig. bandwidth Modbus: 41062 (46062)		
[0]	0.05 Hz	Defines the bandwidth of a filter for the internal
[1]	0.1 Hz	weight value, that is displayed at the front panel
[2]	0.2 Hz	and can be sent to a connected control unit.
[3]	0.5 Hz	Low value: Improves suppression of unstable
[4]	1 Hz	transducer signal, but delays the response to
[5]	2 Hz	fast changes in the transducer signal.
[6]	5 Hz	High value: Gives fast response to changes in
[7]	10 Hz	the transducer signal, but a less accurate value.
[8]	20 Hz	
[9]	50 Hz	
[10]	75 Hz	
	<10 Hz>	
Calibration type Modbus: 41064 (46064)		
[0]	Data sheet	Defines the type of calibration to be performed.
[1]	Deadweight	Data sheet: Data sheet calibration is easy to use
[2]	Table	and doesn't demand any reference equipment,
	<Data sheet>	except data from the transducer data sheet.
		Deadweight: Dead weight calibration is normally
		the most accurate calibration type. It requires
		known weights to at least 2/3 of the wanted
		measuring range.
		Table: Table calibration is used to enter recorded
		values from a previous calibration of the measuring
		equipment to a replacement instrument.

[index]	Range/Alternative <default value>	Explanation and result of alternatives.
---------	--------------------------------------	--

'Data sheet'

Conv. factor Modbus: 41066 (46066)

Range: 0.01 to 99
<9.80665>
Defines the relationship between a measurement value expressed in data sheet unit and expressed in the selected measurement unit.

Number of transd Modbus: 41068 (46068)

Range: 1 to 4
<3>
Defines the total number of transducers and fixed support points in the scale installation. All transducers must have equal rated load.
If the total number is over 4: enter 1 here.

Rated load Modbus: 41070 (46070)

Range: 1 to 999999
Unit: Data sheet unit
<2000.0>
Defines the rated load for one transducer, expressed in the unit of the transducer data sheet.
NOTE! If the data sheet value is for instance 5 kN, this parameter should be set to 5 000 (N).
The value is specified in the transducer data sheet.
If the total number of transducers and fixed supports is over 4: multiply that number with the rated load for one transducer and enter the result here.

Rated output 1 Modbus: 41072 (46072)

Range: 0 – +9.99999
Unit: mV/V
<2.03900>
Defines the rated output signal for transducer 1. The value is specified in the transducer data sheet.
If the total number of transducers and fixed supports is over 4: add up all rated output values, divide by the number of transducers, and enter the result here.

Rated output 2 Modbus: 41074 (46074)

Range: 0 – +9.99999
Unit: mV/V
<2.03900>
Defines the rated output signal for transducer 2.
The value is specified in the transducer data sheet.

Rated output 3 Modbus: 41076 (46076)

Range: 0 – +9.99999
Unit: mV/V
<2.03900>
Defines the rated output signal for transducer 3.
The value is specified in the transducer data sheet.

Rated output 4 Modbus: 41078 (46078)

Range: 0 – +9.99999
Unit: mV/V
<2.03900>
Defines the rated output signal for transducer 4.
The value is specified in the transducer data sheet.

Set zero Modbus: 41088 (46088) and

Zero offset Modbus: 41090 (46090)

See under 'Deadweight' on page 3-20.

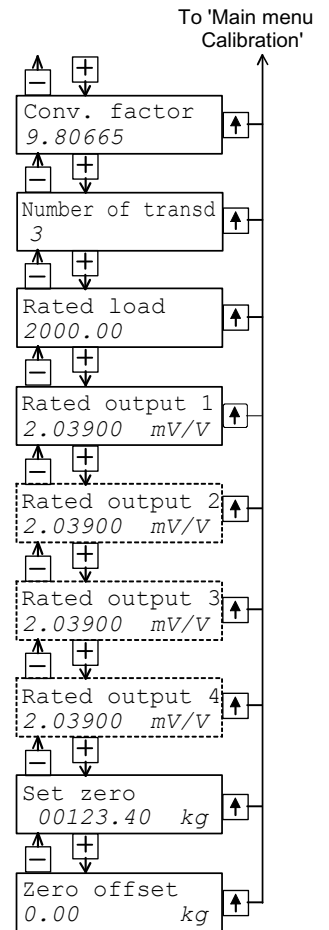

[index]	Range/Alternative <default value>	Explanation and result of alternatives.
---------	--------------------------------------	--

'Deadweight'

Value cal. p.1 Modbus: 41080 (46080)

Range: +/-999999
 Unit: Measurement unit
 Measurement unit: <0>

The scale is calibrated in two points, normally unloaded and loaded to at least 2/3 of the wanted range. This parameter defines the load on the scale in the lower calibration point, normally 0.

Value cal. p.2 Modbus: 41082 (46082)

Range: +/-999999
 Unit: Measurement unit
 Measurement unit: <500>

This parameter defines the load on the scale in the higher calibration point, at least 2/3 of the desired range.

Transd.sign. p.1 Modbus: 41084 (46084)

Range: +/-9.99999
 Unit: mV/V
 Measurement unit: <0.00000>

This parameter indicates the transducer signal in the lower calibration point. The value can not be edited.

Transd.sign. p.2 Modbus: 41086 (46086)

Range: +/-9.99999
 Unit: mV/V
 Measurement unit: <1.66631>

This parameter indicates the transducer signal in the higher calibration point. The value can not be edited.

Set zero Modbus: 41088 (46088)

Range: +/-999999
 Unit: Measurement unit
 Measurement unit: <'Live'>

The actual weight value is displayed. Enter the wanted value for the actual load, usually '0', i.e. unloaded scale.

NOTE ! This parameter should be used for zeroing of the instrument.

Zero offset Modbus: 41090 (46090)

Range: +/-999999
 Unit: Measurement unit
 Measurement unit: <0>

This parameter indicates the offset value acquired by zeroing in 'Set zero'. If this parameter is edited, the zeroing will be influenced.

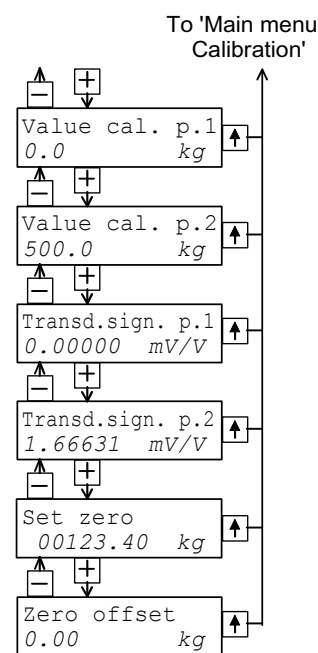

[index]	Range/Alternative <default value>	Explanation and result of alternatives.
---------	--------------------------------------	--

'Table'

Value cal. p.1 Modbus: 41080 (46080)

Range: Calibration with recorded values from a previous
+/-999999 dead weight calibration.
Unit: This parameter should be set to the recorded value
Measurem. unit for the load on the scale in the lower calibration point.
<0>

Value cal. p.2 Modbus: 41082 (46082)

Range: This parameter should be set to the recorded value
+/-999999 for the load on the scale in the higher calibration point.
Unit:
Measurem. unit
<500>

Transd.sign. p.1 Modbus: 41084 (46084)

Range: This parameter should be set
+/-9.99999 to the recorded value of
Unit: mV/V the transducer signal in
<0.00000> the lower calibration point.

Transd.sign. p.2 Modbus: 41086 (46086)

Range: This parameter should be set to
+/-9.99999 the recorded value of
Unit: mV/V the transducer signal in
<1.66631> the higher calibration point.

**Set zero Modbus: 41088 (46088) and
Zero offset Modbus: 41090 (46090)**

See under 'Deadweight' on page 3-20.

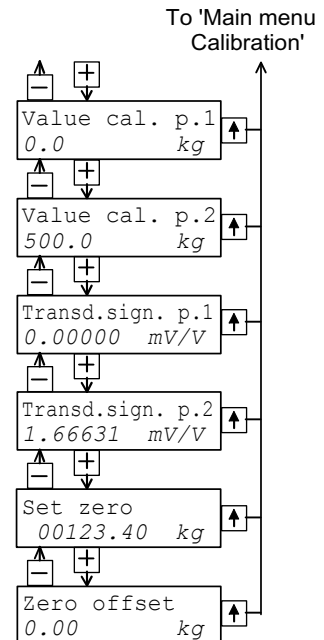

[index]	Range/Alternative <default value>	Explanation and result of alternatives.
---------	--------------------------------------	--

'Main menu Diagnostics'

Status input 1 Modbus: 41360 (46360)

[0]	Off	Displays the status of digital input 1.
[1]	On	No changes can be made.

Status input 2 Modbus: 41362 (46362)

[0]	Off	Displays the status of digital input 2.
[1]	On	No changes can be made.

Test relay 1 Modbus: 41364 (46364)

[0]	Off	This parameter controls the state of relay 1. Off: Relay 1 is deactivated. On: Relay 1 is activated.
[1]	On	
	<Off>	

Test relay 2 Modbus: 41366 (46366)

[0]	Off	This parameter controls the state of relay 2. Off: Relay 2 is deactivated. On: Relay 2 is activated.
[1]	On	
	<Off>	

Test ana. outp. Modbus: 41368 (46368)

Range:	Setting of a fixed value at the analogue output.
+/-11 or +/-22	A suitable unit is added automatically.
Unit: mA or V	
<0>	

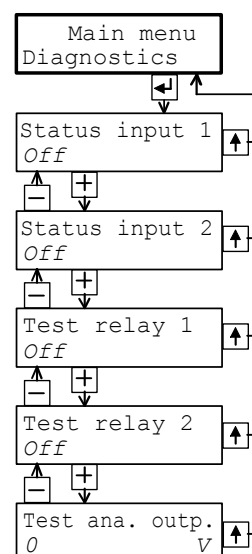

'Main menu Exit set-up'

Save changes?

Range: To exit from Set-up mode, No, press in 'Main menu Exit set-up'. Esc. If any parameter values have been changed 'Save changes? No Esc. Yes' is displayed. Yes (Press if you do not wish to exit from the set-up mode.)

Press (Yes) to exit from Set-up mode and save the new parameter values.

Press (No) to exit from Set-up mode and cancel the new parameter values.

This finishes the set-up operation, AST 3IS will switch over to Operating mode, displaying the 'Weight value'.

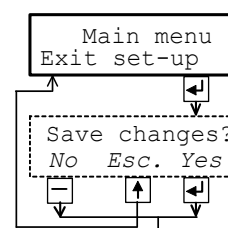

Operating mode

4. Calibration

General

When measuring with AST 3IS, the transducer output signal, corresponding to the transducer load, is converted to weight value and presented at the analogue output, and at the AST 3IS panel or at a connected control unit. The conversion is controlled by several parameter values, defined in the calibration.

Three calibration types are supported in AST 3IS:

- **Data sheet calibration** - entry of values from the transducer data sheet.
- **Dead weight calibration** - entry of values at certain known loads.
- **Table calibration** - entry of recorded values from a previous calibration.

It is recommended to start with a data sheet calibration, which is easy to accomplish and will give a fairly good accuracy.

To get the best accuracy a dead weight calibration, with known loads to at least 2/3 of the measuring capacity, must be performed.

After calibration the parameter values should be recorded. See appendix 1.

If the transmitter module must be replaced, the recorded values can be used to make a table calibration for the new module.

All calibration parameters are gathered under 'Main menu Calibration'.

See section 3 Set-up, Parameters and figure 8.

In weighing applications it is essential for correct results that fixed mechanical connections to the scale are avoided. Necessary connections must be flexible and perpendicular to the measuring direction. If the scale has several transducers connected in parallel, they must have the same rated load and impedance. If fixed supports and transducers are combined, the load must be evenly distributed on all the support points.

DATA AND CALIBRATION SHEET				ArtNo: 1130480
LOAD CELL	KIS-3	S/N	322471	
RATED LOAD (R.L)	10 kN	!	EXCITATION VOLTAGE, RECOMMENDED	10 V AC OR DC
			EXCITATION VOLTAGE, MAXIMUM	18 V AC OR DC
OVERLOAD, SAFE	100 % R.L.	!	INPUT RESISTANCE	350 +/- 3 OHMS INCL. STANDARD CABLE
OVERLOAD, ULTIMATE	200 % R.L.	!	OUTPUT RESISTANCE	350.1 OHMS INCL. STANDARD CABLE
SIDE LOAD, SAFE	100 % R.L.	!	TEMPERATURE RANGE	-40 TO +80 DEGREES C
SIDE LOAD, ULTIMATE	200 % R.L.	!	TEMPERATURE EFFECT (-10 TO +50 DEGREES C)	
ELECTRICAL CONNECTION	SHIELDED 4-CONDUCTOR CABLE	!	ON OUTPUT	0.001 % OF OUTPUT PER DEG. C
EXCITATION POSITIVE:	RED	!	ON ZERO BALANCE	0.001 % OF R.O. PER DEG. C
EXCITATION NEGATIVE:	BLACK	!		
SIGNAL POSITIVE:	GREEN	!		
SIGNAL NEGATIVE:	WHITE	!		

RATED OUTPUT (R.O.) (TOLERANCE 0.1 %)			2.0394 mV/V	
NONLINEARITY (BEST FIT THROUGH ZERO)		+/-	0.010 % R.O.	
ZERO BALANCE			+0.0 % R.O.	
CREEP 5 MINUTES			+0.001 % R.O.	
CALIBRATION VALUES (TOLERANCE 0.1 %) SHUNT RESISTOR CONNECTED BETWEEN 'EXCITATION NEGATIVE' AND 'SIGNAL NEGATIVE'				
40 KOHMS CORRESPOND TO			9.9111 kN	
80 KOHMS CORRESPOND TO			4.9683 kN	
THE VALUES INDICATED FOR OUTPUT VOLTAGE AND CALIBRATION VALUES ARE APPLICABLE AT OPEN CIRCUIT WITHOUT EXTERNAL BALANCING RESISTORS AND WITH A CONNECTING CABLE OF STANDARD LENGTH.				
Vishay Nobel AB S-691 27 KARLSKOGA			KARLSKOGA 03-04-30	

Figure 10. Each transducer from Nobel Weighing Systems is delivered with a detailed data and calibration sheet.

Common calibration parameters

For all the calibration types, measurement unit and resolution for the weight value and some other characteristics must be specified. The sequence of these parameters, common for all calibration types is given on pages 3-17 and 3-18.

The parameter 'Measurement unit' defines the engineering unit used for the weight value. This engineering unit will also be used for the Resolution and Capacity, for the Level values and for set-up of the analogue output.

The 'Resolution' parameter defines the number of decimals and the resolution for the weight value, displayed at AST 3IS or transmitted to external equipment. If the weight value is oscillating, reduced resolution will give a more stable reading with reduced accuracy.

'Capacity' is a parameter, defining which weight value that will give full range signal at the analogue output.

(The weight values corresponding to the highest and the lowest analogue output signals are also set by parameters under 'Main menu Analogue output'.)

The parameter 'Mains frequency' controls filters for suppression of induced low frequency noise. It should be set to the surrounding mains frequency.

The parameter 'Dig. bandwidth' controls the filtering of the internal measurement signal. Low digital bandwidth gives a suppression of oscillations in the signal, making the reading more stable. High digital bandwidth makes it possible to detect fast changes in the measurement value.

In the following parameters under 'Calibration', calibration type and parameter values for the latest performed calibration are displayed.





If 'Calibration type' is not edited, the values from previous calibration, including the zero offset value, will be displayed for the parameters.

If 'Calibration type' is edited, even if it is not changed, the zero offset value will be set to zero, so at least a new zeroing is required.

Editing of parameter values, including the type of calibration, should be performed according to instructions on page 3-9.

Example:

Select a different type of calibration in 'Calibration type'

1. As menu 'Calibration type' is displayed, press  and a cursor will make the first character on the lower line blinking.
2. Find the wanted calibration type, using the key  or  until the correct alternative is displayed.
3. Accept the displayed calibration type by pressing  for 2 seconds. The cursor disappears and the selected calibration type will be displayed.

Data sheet calibration

Data sheet calibration is the default value for 'Calibration type' because it is recommended as first-time calibration for AST 3IS. An accuracy of 0.1 % can be obtained without use of known loads etc. By data sheet calibration in weighing applications it is essential that no external forces influence the scale installation. In data sheet calibration, values from the transducer data sheets should be entered as parameter values.

Conv. factor

The transducer is often calibrated in an engineering unit which differs from the unit of the displayed measurement value. This parameter defines a constant by which a weight value, expressed in the measurement unit, should be multiplied to be expressed in the data sheet unit.

When using a transducer, calibrated in Newton, in a scale displaying weight values in 'kg', the 'Conv. factor' shall be the local gravitation constant in m/s^2 .

The default value, 9.80665, is an international mean value for the gravitation constant (world-wide range 9.78 – 9.83).

If the data sheet unit is the same as the measurement unit, the conversion factor parameter value should be set to 1.0000.

Number of transd

In weighing applications the load on the scale may be supported by several transducers and fixed supports. This parameter value defines the total number, up to four, of transducers and fixed support points. If the scale has more than four support points this parameter should be set to '1' and the parameter value for 'Rated load' and 'Rated output 1' should be calculated.

Rated load

Rated load for the used transducer type, expressed in the data sheet unit used to calculate the conversion factor, should be entered as parameter value.

If the data sheet value is for instance 5 kN, this parameter should be set to 5 000 (N).

If several transducers are used in a scale, they must all have the same rated load.

If the scale has more than four support points, 'Number of transd' should be set to '1' and the value of this parameter should be calculated as:

rated load for one transducer, multiplied by the total number of support points.

Rated output 1

Rated output is given in the data sheet for every transducer and should be entered here. Similar parameters follow for the number of support points indicated in 'Number of transd'. For fixed supports, the rated output value is 0.00000 (mV/V).

If the scale has more than four support points, 'Number of transd' should be set to '1' and the parameter value for 'Rated output 1' should be calculated as:

the mean valued of rated output for all active transducers.

Set zero

After the data sheet values have been entered as parameter values, the instrument will perform necessary calculations, and a weight value corresponding to the actual load on the transducer will be displayed here.

The parameter value is set to zero as  (enter) is pressed.

This zero value can be accepted, if  is pressed for 2 seconds, or

edited (numerical value) and then accepted as  is pressed for 2 seconds.

Zero offset

This parameter indicates the zero offset value needed to get the 'zero' value, selected for the parameter 'Set zero'.

Dead weight calibration

This is normally the most accurate calibration type. The transducer signal is measured and stored together with the entered value of the known load (expressed in the selected measurement unit) for two calibration points.

It is essential for good accuracy to utilise calibration points in both ends of the measuring range, for example at zero load and at least 2/3 of rated load.

Make a manual record of all values, see appendix 1!

Value cal. p.1,

Apply a well defined low load on the scale, normally 0 (zero), and enter the value of the load as parameter value. The entered load value and corresponding transducer signal value are saved in the instrument.

Value cal. p.2

Apply a well defined high load on the scale, at least 2/3 of the rated load, and enter the value of the load as parameter value. The entered load value and corresponding transducer signal value are saved in the instrument.

Transd.sign. p.1,

This parameter indicates the stored transducer signal value for the low calibration point. The parameter value can not be edited.

Transd.sign. p.2

This parameter indicates the stored transducer signal value for the high calibration point. The parameter value can not be edited.

Set zero

See under Data sheet calibration on page 4-3.

Zero offset

See under Data sheet calibration on page 4-3.

Table calibration

The table calibration can be used to copy values from a dead weight calibration for AST 3IS to a replacement instrument. It is necessary to have access to recorded values from a dead weight calibration in two points.

As Table calibration is selected, the 'zero offset' value is not set to zero.

Value cal. p.1, Value cal. p.2

These parameter values should be set to the recorded weight values from a previous calibration for the low calibration point (p.1) and the high calibration point (p.2).

Transd.sign. p.1, Transd.sign. p.2

These parameter values should be set to the recorded transducer signal values from a previous calibration for the corresponding calibration points.

Set zero

See under Data sheet calibration on page 4-3.

Zero offset

See under Data sheet calibration on page 4-3.

5. Operation

General

There are several versions of AST 3 with identical measuring and set-up functions. For all versions, the function control and parameter set-up can be performed by serial communication from a control unit. This section only describes operation and function control for the instrument version AST 3IS.

Power supply

The signal transmitter is powered by 24 VDC and should not be turned off during week-ends and over-night. Continuous power supply to electronics and transducer prevents moisture condensation in the units.

Power-up sequence

When AST 3IS is powered up it displays 'AST 3', the programme name, and the serial number of the module for about five seconds while a number of internal tests are performed.

If errors are detected the power-up sequence stops and an error code is displayed. See section Troubleshooting for further information.

If no errors are detected the module enters Operating mode (by automatic start-up), displaying the weight value and relay status, or the module enters the 'Wait for start' state (by operator start-up), displaying the text 'Press ENTER to start operation!'. Automatic or operator start-up is selected with the set-up parameter 'Start mode' under 'Main menu General'.

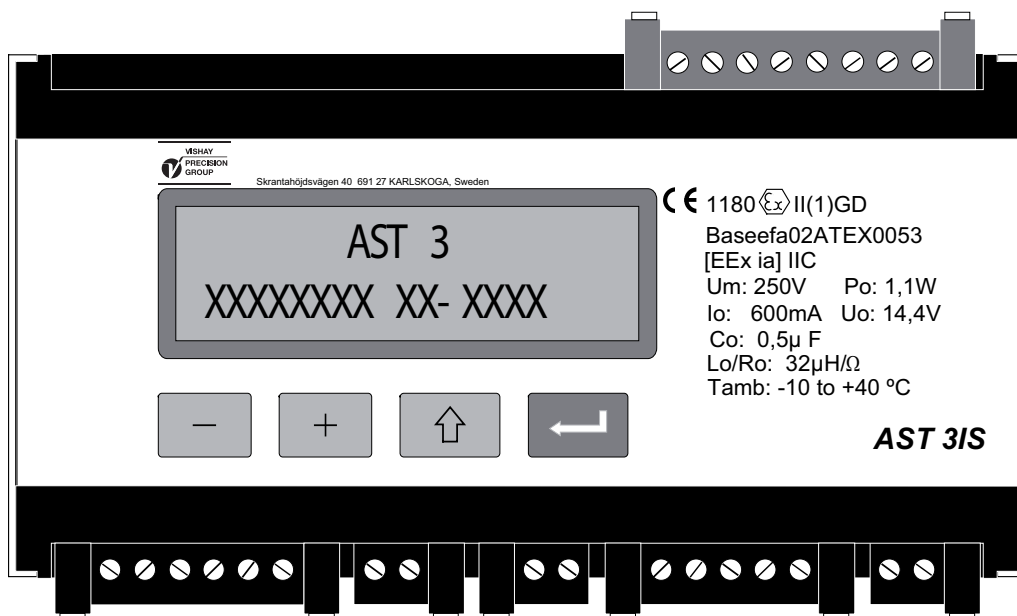

Figure 11. AST 3IS during the power-up sequence.

Display views in Operating mode

Figure 12.

For AST 3IS in Operating mode, at least one of the display views, Weight value, is always available. More views can be set On or Off in parameters under 'Main menu General'. The panel keys and are used to select among the available views.

In 'Weight value', and in some other views, information about serial communication is given at the end of the upper line:

The module address means communication with a control unit.

'EXT' means communication to an external display unit.

No indication in this area means that the serial communication is not in use.

Weight value

This is the first view displayed after power-up, reset or set-up operations.

The upper line displays the actual measurement value, here called weight value, followed by the area with information about the serial communication.

The lower line displays the status for the used relays, R1:/R2: On or Off.

Zero setting

This view can be set On or Off by parameter 'Zero function'. Actual weight value, and information about the serial communication, is displayed.

'Zero' on the lower line indicates that the weight value can be set to zero by .

NOTE! If AST 3IS is switched off, or switched over to Set-up mode, the zero setting by this view will be lost and replaced by the zero setting from the previous calibration.

Analogue output signal

This view can be set On or Off by parameter 'More views'.

The upper line displays the actual weight value, followed by the area with information about the serial communication.

The lower line displays the signal at the analogue output, a value in V or mA depending on the choice for parameter 'Ana. output type'.

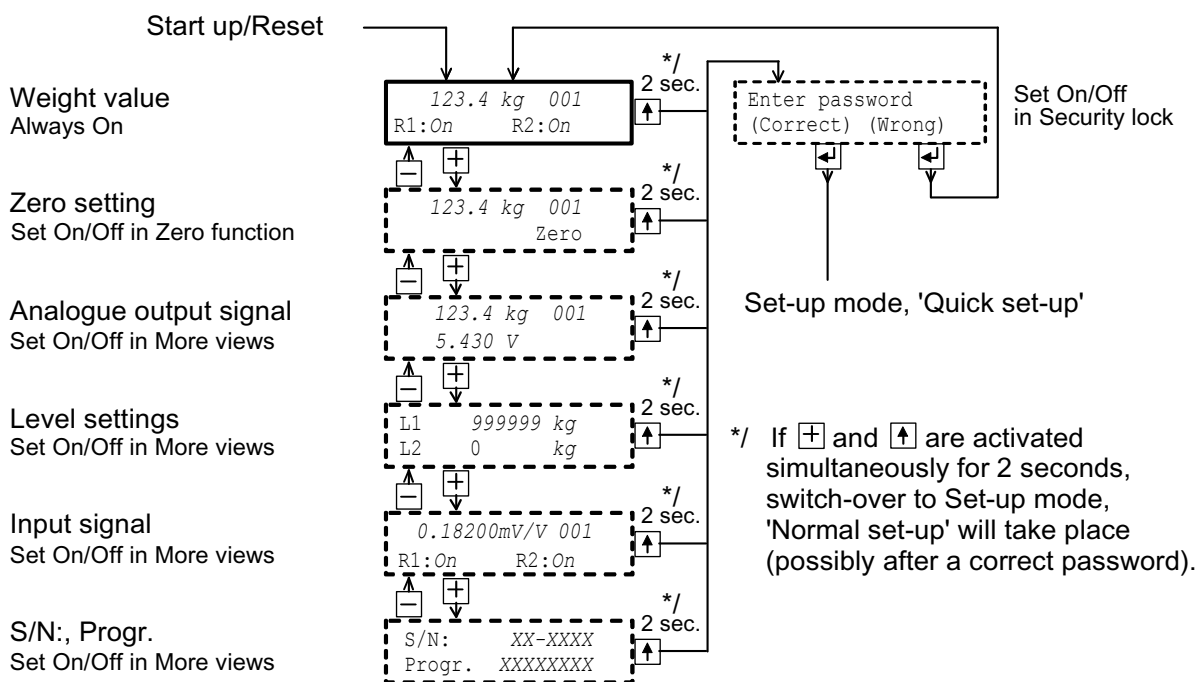

Figure 12. The number of views available in Operating mode depends on several parameter settings.



Level settings

This display can be set On or Off by parameter 'More views'.
At the upper line the switching level for 'Level 1' is displayed.
At the lower line the switching level for 'Level 2' is displayed.

Input signal

This display can be set On or Off by parameter 'More views'.
The upper line displays the transducer input signal for the actual load, a value in mV/V, followed by the area with information about the serial communication.
The lower line displays the states of the used relays, R1:/R2: On or Off.

S/N:, Progr.

This display can be set On or Off by parameter 'More views'.
The upper line displays the serial number for the AST 3IS module and the lower line displays the name of the installed programme.
From any of the above display views AST 3IS can be switched over to Set-up mode.
'Quick set-up' is started if the key  is pressed for 2 seconds. See figure 7.
'Normal set-up' is started if  and  are pressed for 2 seconds. See figure 8.

Zero setting

Zero setting of the weight value is normally performed as the AST 3IS unit is calibrated. By calibration the value of the zero offset parameter is permanently saved in the AST 3IS memory and can only be changed in Set-up mode.

Temporary zero setting can be performed from the zero setting view in Operating mode, enabled by parameter 'Zero function' under 'Main menu General'.

NOTE! The zero offset value captured by this later method is lost if the AST 3IS is unpowered or if Set-up mode is entered.

A third way of zero setting is via a serial communication command.

NOTE! The zero offset value captured by this method is lost if the AST 3IS is unpowered or if Set-up mode is entered.

Analogue output

AST 3IS has an analogue output with several voltage and current output ranges. The range limits are very precise, but minor adjustment can be done to adapt the output to the external equipment.

A separate analogue output filter with a wide span of variable bandwidth can be set to reduce oscillation of the output signal, or to enable registration of fast changes by the analogue output.

If an error occurs, the analogue output signal will be set to 0 V / 0 mA.

One way to select the range of measurement value, presented at the analogue output, is by parameter 'Capacity' in 'Quick set-up'.

Another way is to select any measurement value for the lowest and for the highest output signal respectively under 'Main menu Analogue output'.

The analogue output can also be set to precise, fixed voltage or current output, independent of the internal weight value.

Level supervision, relays

Level supervision is used to indicate whether a selected signal is above or below a certain level. In AST 3IS two level supervision channels are included. For each channel, supervised signal, switch level, and hysteresis region are set individually by parameters under 'Main menu Level superv.'.

To get fast response, the analogue or digital bandwidth, whichever is highest, is used for the supervision channels. The status of the level supervision channels (above or below Level) are available on the serial communication.

In AST 3IS two output relays with switching contacts can be set to indicate either the status of the supervision channels, or if AST 3IS is 'In process'.

If an instrument error occurs, both relays will be deactivated.

See page 3-10 and 3-11 for set-up sequence and parameters for the level supervision.

Level 1 (2) source

Two signals can be selected for supervision in the two channels:

Input sign. mV/V: Supervision of the input signal from the transducer.

Weight : Supervision of the measurement value, named weight value, can be used to keep the load on a scale within given limits, to maintain a working pressure etc.

Level 1(2) value

The switching levels are set individually for the two level supervision channels within a wide range of positive and negative values. A suitable engineering unit is automatically added, depending on the selected level source.

Level 1(2) hyst.

Hysteresis is the difference between the switching level by increasing signal and by decreasing signal. The hysteresis can be set separately for the channels within a wide range of positive and negative values. A suitable engineering unit is automatically added, depending on the selected level source.

The positive hysteresis region is from the Level value and upwards.

The negative hysteresis region is from the Level value and downwards.

Relay 1(2) source

Two relays in AST 3IS can be controlled either by the level supervision channels or by the 'In process' signal.

In process The relay is active as AST 3IS is in Operating mode.

Above level The relay is active as the value of the selected signal source is above the set switch level, hysteresis included.

Below level The relay is active as the value of the selected signal source is below the set switch level, hysteresis included.

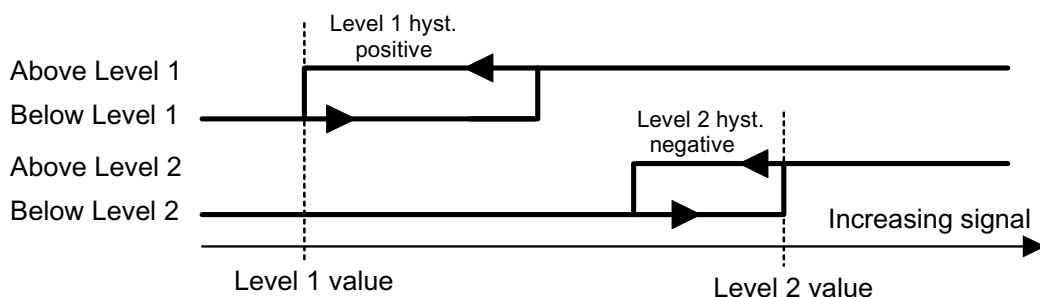

Figure 13. Influence of hysteresis on the indication from level supervision.
Level 1 having positive hysteresis and
Level 2 having negative hysteresis.

6. Communication

The analogue signal transmitter AST 3IS has one serial communications port, primarily used for communication with a control unit. Alternatively it can be used for data transmission to an external display.

Communication interface

The serial communication utilises RS-485 for 2-wire or 4-wire. RS-485 is an interface working with differential voltages, giving a noise resistant transmission in a network with several units and long distances. The host computer (master) must have an asynchronous communication port for RS-485, or use a converter, e.g. Westermo MA-42 for RS-232 to RS-485 conversion.

If 2-wire transmission is used, the control unit must be capable of data flow direction control or utilise a converter for automatic data flow direction control e.g. Westermo MA-44.

When 4-wire transmission is used, no data flow direction control is needed.

Line termination

To ensure good communication, the RS-485 transmission line requires correct termination at both ends. In the AST 3IS unit, fail safe resistors are always included, but at the last unit on the transmission line, terminating resistor(s) must be connected, see section Installation.

If the control unit is connected at one end of the transmission line, refer to the computer manual for line termination.

Transmission principles

All the AST 3IS units connected to the network can listen to what is transmitted in the network, but only one unit at a time can transmit. A time sharing principle is needed to allow communication in both directions (half duplex).

All communication in the network must be initiated by the control unit (master). When AST 3IS is working together with a master the units are all slaves, only allowed to reply to master commands. As the master has addressed a command message to a specific slave unit, it listens for the reply during a specified time, before sending next command message.

If the reply from a slave unit fails it may be due to:

- Mismatch in communication parameters. (baud rate, address, . . .)
- More than one slave unit has been transmitting at the same time. This can distort the reply message and make it impossible to decode.

Modbus

General

For communication with a master computer (PLC) the Modbus protocol is used in the AST 3IS. The Modbus protocol is a standard protocol, used for master/slave communication in the industry. The AST 3IS implementation works with the Modbus RTU (binary) format and is a subset of Modbus function codes. The ASCII format is not supported.

Information is transmitted in blocks of data to minimise polling and response time delays. For example both the error register, status register and weight register could be read with one command to the AST 3IS.

When a command that can not be performed is sent, the AST 3IS responds with an exception code. For a better explanation of the error, a special error register could be read.

Depending on the type of the communicating equipment (the master), the commands in the application programme (PLC programme, or pc programme) may be different from type to type. However, if the master is not a Modicon PLC system, then the Modbus implementation in the master must have some cross-reference function to transfer the Modbus register and I/O bit numbering to the masters own register and I/O bit numbering. All register, coils described in this manual uses the standard Modbus (Modicon) register and I/O numbering. See the masters own Modbus driver documentation for how the commands should be activated in the masters application programme.

For detailed information about the Modbus protocol see:

Modicon Modbus Protocol Reference Guide PI-MBUS-300 Rev.D.

Setup of Modbus communication

Set parameter 'Serialport mode' (in 'Main menu Communication') to 'Modbus auto'. The baudrate and bit settings will be autodetected.

The AST 3IS will be given the address 1 as default. If more than one AST 3IS is used in a network, each one of them must be given a unique address in parameter 'Instrum. address'. (The address is shown to the right in the display on the AST 3IS and when a correct message is received, it flashes.)

Supported Modbus functions

Function	Description
01 Read Coil Status	<p>Reads the ON/OFF state of discrete outputs (0X references, coils). This function is only implemented because some 'masters' use this function to initialise communication (check that the communication is working OK). Coil range: 1 – 16 Max number of points to read: 16 Action: AST 3IS will respond with zero (OFF) for all requested points.</p>
02 Read Input Status	<p>Reads the ON/OFF state of discrete inputs (1X references). This function is implemented only because some 'masters' use this function to initialise communication (check that the communication is working OK). Input range: 1 – 16 Max number of points to read: 16 Action: AST 3IS will respond with zero (OFF) for all requested points.</p>
03 Read Holding Reg.	<p>Reads the binary contents of holding registers (4X references). This function will read selected number of consecutive registers from the AST 3IS. Available registers in the AST 3IS are described below. Max number of registers to read: 100 Action: AST 3IS will respond with the contents of the requested registers.</p>
	<p>Forces a single coil (0X references) to either ON or OFF. This function is used to activate actions in the AST 3IS (see description of I/O bits later in this chapter). Each of a number of coils or I/O bits, is linked to an action in the AST 3IS. The action is activated if the master sets the I/O bit to 'ON'. If the master sets the I/O bit to 'OFF', this is accepted, but the corresponding action is not activated. Coil range: 1 – 110</p>
06 Preset Single Reg.	<p>Presets a value into a single holding register (4X references).</p>
08 Diagnostics	<p>This function can provide a series of different communication tests, depending on a sub function code. AST 3IS supports only sub function code 00, which is a 'loop-back' test. The same data as received will be sent back to the master. Max number of data bytes: 64</p>

Function	Description
	<p>Forces each coil (0X references) in a sequence of coils to either ON or OFF.</p> <p>This function is used to activate an action in the AST 3IS (see description of I/O bits below). Each coil or I/O bit is linked to an action in the AST 3IS. The action is activated if the master sets the I/O bit to 'ON'. If the master sets the I/O bit to 'OFF', this is accepted, but the corresponding action is not activated.</p> <p>NOTE! Even though it is possible to set multiple I/O bits (coils) with this function, AST 3IS will act on the lowest addressed I/O bit (coil) only.</p> <p>Example: To set coil 8, the first coil to set must be number 8.</p> <p>I/O bit (coil) number range: 0 – 110 Max. number of points: 16 (only the first is used)</p>
16 Preset Multiple Reg.	<p>Presets values into a sequence of holding registers (4X references).</p> <p>This function will preset values into the selected number of consecutive registers in the AST 3IS.</p> <p>Max number of registers to preset: 100</p>

Note: No broadcast messages are allowed.

NOTE! It is possible to send or fetch any number of registers (max 100) or I/O bits (max. 16). If the master tries to read more registers than there are available, the AST 3IS module will send dummy values for those registers not available.

Data representation

Data values (weight values and setpoint values) sent to and from the AST 3IS uses 16 bit holding registers (40XXX).

All operative parameters: weight, status, etc. are stored in three different register areas in the AST 3IS. Which area that should be used depends on the master (PLC).

Integer area: Two different types

- 16 bit unsigned integer
- 32 bit scaled integer

Float area

Modicon float area

Operative parameters Integer area

Unsigned integer (1 modbus register)

Error codes, status etc. are saved in one modbus register as an unsigned integer (16 bit number without decimals).

Scaled integer (2 modbus registers + 1 modbus register = 3 modbus registers)

Values bigger than 32767 and values containing decimals (Weight, levels) are always saved in a special 3 register format. The first two registers are used as a 32 bit long integer value (with sign) and the third register is holding the number of decimals in the value.

Example: 12345678 (32 bit number) in the two first registers and 3 in the third register gives the value: 12345.678.

Register	Binary	Hexa-decimal	Decimal	Description
1	0000 0000 1011 1100	00BC	188	The 16 most significant bits in the value.
2	0110 0001 0100 1110	614E	24910	The 16 least significant bits in the value.
3	0000 0000 0000 0011	0003	3	The number of decimals.

Depending on number of decimals, divide the value with a number from these tables.

Decimals	Number to divide with
0	1
1	10
2	100

Decimals	Number to divide with
3	1000
4	10000
5	100000

Calculations in decimal numbers:

First multiply the most significant register with 2^{16} (65536) and add the least significant register to the value.

$$188 * 2^{16} + 24910 = 12345678$$

Now divide the number to get the right number of decimals.

The decimal register was set to 3 in this example, which gives the value $10^3 = 1000$ to divide with.

$$12345678 / 1000 = 12345.678$$

Note: If your PLC system can't handle 32 bit values, the second register can be used as a 16 bit register with the number of decimals that is indicated in the third register. This will limit the value range to -32768 to +32767. This must be regarded in the calibration of the instrument. A flag in Status register 1 indicates when the weight is bigger than a 16 bit integer. This flag can be checked to be sure that the weight fits in just one register.

Operative parameters float area & Set-up parameters

The set-up parameters, and the operative parameters are stored as standard IEEE 32 bit float values. Each value has two registers assigned to it.

To read/write a float value an even number of Modbus registers, starting at an even address, must be read/written each time.

The parameters are stored in two different float formats. Some devices may transfer the values with the high order bits in the first register and the low order bits in the second register. Other devices may invert the register order.

Modicon float: For true Modicon PLC's, use these register areas.

Float: Many third party controllers that support Modicon protocol use the float format where all bytes are written out in order to one 32 bit register, as opposed to Modicon float which uses 2 consecutive 16 bit registers. Use these register areas for these types of controllers.

Register description - Process parameters

AST 3IS simulates a number of Modicon 'Holding Registers' (registers 4XXXX ...). These are 16 bits binary registers and holds the data that can be transferred between the master and the AST 3IS. Some of these registers can only be read from the master, while others can both be read from and written to.

The Modbus function 03 'Read Holding Registers' should be used to read these register and the Modbus function 05 'Preset Single Register' or 16 'Preset Multiple Registers' should be used to write to the registers. This table is a summary of all process parameters in the AST 3IS. The leftmost column holds the registers that should be used when float numbers can't be read, and the next two columns hold the register numbers for parameters in float format.

A good way to find out which of the float formats that should be used is to read the 'Instrument type' register (40200/45200) which should equal 2001 for AST 3IS.

Register area Integer	Register area Float (2 reg./value)	Register area Modicon float (2 reg./value)	Explanation	R/W
40001 (1 reg)	40200	45200	Instrument type	R
40002 (1 reg)	40202	45202	Program number	R
40003 (1 reg)	40204	45204	Program version	R
40004 (3 reg)	40208	45208	Serial number	R
40007 (1 reg)	40210	45210	Command error	R
40008 (1 reg)	40212	45212	Instrument state	R
40009 (1 reg)	40214	45214	Instrument error	R
40010 (1 reg)	40216	45216	Status 1	R
40011 (1 reg)	40218	45218	Status 2	R
40012 (3 reg)	40220	45220	Weight	R
40024 (3 reg)	40228	45228	Analogue output value	R
40027 (3 reg)	40230	45230	Input signal (mV/V)	R
40030 (1 reg)	40232	45232	Command register	R/W *
40031 (3 reg)	40234	45234	Level 1 value	R/W
40034 (3 reg)	40236	45236	Level 2 value	R/W
40037 (3 reg)	40238	45238	Analogue fixed value	R/W

Important: The weight register should never be read alone because the status of the value is indicated in some other registers. A good choice is to read at least the registers 40009 – 40014 (integer) or the registers 40214 – 40221 (45214 – 45221) (float).

*/ The read value is always 'zero'.

Instrument type register

This is a READ ONLY register.

This register holds the type of the instrument. For AST 3IS this value is 2001.

Program number

This is a READ ONLY register.

This register holds the program number of the AST 3IS. Normal programs has a value below 100 and special programs a value above 100.

Program version

This is a READ ONLY register.

This register holds the program version of the AST 3IS. The value 100 means 1.00.

Serial number

This is a READ ONLY register.

This register holds the serial number of the instrument.

The value 971000 means 97-1000.

This can be used by the master to be sure that a instrument with a specific serial number is used for a special process.

Command error

This is a READ ONLY register.

This register holds the error code when a command has been sent to the AST 3IS.

A command that gives a 03 or 07 as exception will have an error code with a better description of the problem in this register. For an explanation of the error codes see chapter 7 Troubleshooting. Normally this register should contain '00' which means no error. Error codes 100 to 65535 are valid in this register.

Instrument state register

This is a READ ONLY register.

This register contains the state of the AST 3IS unit.

Code	Description
00	'Starting up' state. The instrument is starting up after a reset or power on.
01	'Wait for start' state. The AST 3IS is waiting for a start command to go in process.
02	'Normal' state. There are no parameter errors in the system. Note: Weight errors still indicates normal state.
03	'Local Set-up' state. Someone is modifying the set-up parameters from the front of the AST 3IS. It's not possible to enter Remote Set-up or Remote Restore state from here.
04	'Remote Set-up' state. A master computer is modifying the set-up parameters in the AST 3IS. It's not possible to enter Local Set-up state from here.
05	'Remote Restore' state. A master computer is restoring a full set-up to the AST 3IS. It's not possible to enter Local Set-up state from here.
06	'Error' state. An error has been detected during start up of the instrument.
07	'Fatal error' state. An error has been detected during start up of the instrument. It's not possible to enter any other state from here.
08	'Test' state. AST 3IS is running in a special mode used for service and production test.
99	'Boot' state. The AST 3IS is ready to receive a new program.

Instrument error

This is a READ ONLY register.

This register holds the error code in the AST 3IS, for example weight, RAM, Flash, EEPROM errors. For an explanation of the error codes see chapter 7 Troubleshooting. Normally this register should contain '00' which means no error. Error codes 000 to 099 are valid in this register.

Status register 1

This is a READ ONLY register.

The register status bits have the following meaning (bit = 1 means true while bit = 0 means false). (Bit 0 is the least significant bit in the register).

The bits not mentioned in the table are always zero.

Bit no	Function	Comment
1	Weight > INT size	The weight value occupies more than one register. Useful information if the weight in 'scaled integer' format is handled as a 16 bit value.
13	Weight > 6 digits	The weight value is out of precision and should normally not be used.

Note: When this register is read in the float area a float value representing the bits set, is returned. For example if bit 13 is set the value 8192.0 is returned as a float value, and if both bit 1 and bit 13 is set the value 8194.0 is returned as a float value. To use the value it's a good choice to convert it to an unsigned value where the bits can be compared.

Status register 2

This is a READ ONLY register.

The register status bits have the following meaning (bit = 1 means true while bit = 0 means false). (Bit 0 is the least significant bit in the register)

The bits not mentioned in the table are always zero.

Bit no	Function	Comment
0	Relay 1 activated	
1	Relay 2 activated	
4	Power failure	The 'power failure' bit is cleared when a 'Read Holding Reg.' (function 03) command reads this register Status 2 (however, the reply contains the set bit, if it was set).
6	Fixed analogue output	The analogue output is working in fixed mode, and new fixed values can be loaded in the 'Analogue fixed value' register.
7	Digital input 1 activated	There is a 24V signal active on the input.
8	Digital input 2 activated	There is a 24V signal active on the input.
9	Above Level 1	The weight (or mV/V value) is above level 1.
10	Above Level 2	The weight (or mV/V value) is above level 2.
11	Analogue output voltage/current	Bit set indicates voltage.

Note: When this register is read in the float area a float value representing the bits set, is returned. For example if bit 4 is set the value 16.0 is returned as a float value, and if both bit 0 and bit 4 is set the value 17.0 is returned as a float value. To use the value it's a good choice to convert it to an unsigned value where the bits can be compared.

Weight

This is a READ ONLY register.

This register holds the weight. The weight should **not** be read alone because the status and error codes are stored in other registers. The weight is only valid when the register 'Instrument error' equals 00.

A good choice is to read at least the registers 40009 – 40014 (integer) or the registers 40214 – 40221 (45214 – 45221) (float).

Analogue output value

This is a READ ONLY register.

This register holds the current output signal on the analogue output. This register could be used for fault finding in the system.

Note: The value is rounded to two decimals.

Input signal (mV/V)

This is a READ ONLY register.

This register holds the current input signal in mV/V. This register could be used for fault finding in the system.

Command register

As this register is read, the answer will always contain only zero's.

There are a number of actions that can be activated in the AST 3IS. The value of this register (when different from zero) will activate one of these actions, as described below. When an action can not be performed for some reason (wrong state etc.) an exception is given as reply. When an exception with code 03 or 07 is received the command error register could be read to get a better error explanation.

Register value	Action activated in AST 3IS
8	Set to zero This command is used to set the instrument to zero.
16	Start operation When the AST 3IS is in 'Wait for start state', this command can be used to start up the instrument.

Level 1 value, Level 2 value

These are READ/WRITE registers.

The registers are used to set temporary levels for the relays. At start up these level values are fetched from corresponding set-up parameters (saved in the memory), which means that the values written to these registers are only valid up to reset or power fail.

Analogue fixed value

This is a READ/WRITE register.

The register could be used to set new temporary values on the analogue output, when the analogue output is configured as 'Fixed+/-20mA' or 'Fixed+/-10V' in the set-up. At start up the value is fetched from corresponding set-up parameter (saved in the memory), which means that a value written to this register is only valid up to reset or power fail.

I/O bit (coil) description

AST 3IS simulates a number of I/O bits that the master can write to using Modbus function 05 or 15.

Each of these I/O bits, is linked to an action in the AST 3IS. The action is activated if the master sets the I/O bit to 'ON'. If the master sets the I/O bit to 'OFF', this is accepted, but the corresponding action is not activated.

All I/O bits are WRITE ONLY. That is the master cannot read the I/O bits but only write to them. An action is performed in the AST 3IS when the master writes to an I/O bit. Modbus function 05 'Force Single Coil' or Modbus function 15 'Force Multiple Coils' should be used to write to I/O bits.

Note: If the master tries to write to more than one I/O bit (Modbus function 15) the AST 3IS will act on the lowest I/O bit number only.

Coil	Action activated in AST 3IS	Description
8	Set to zero	This command is used to set the instrument to zero
16	Start operation	When the AST 3IS is in 'Wait for start state', this command can be used to start up the instrument.
100	Enter Remote Set-up	This command is used to be able to change the set-up of the AST 3IS from remote.
101	Enter Remote Restore	This command is used to be able to restore a saved set-up to the AST 3IS from remote.
102	Exit Remote Set-up/Restore and save changes	This is used when the parameters are changed from remote and should be saved in the AST 3IS.
103	Exit Set-up without saving changes	This can be used to discard edits made to the set-up parameters, before the set-up is left.
104	Do Reset	This command is used to reset the instrument from remote location.
105	Check set-up data	This command checks that the set-up is correct.

Exception responses

When the master sends a query to a slave it expects a normal response (as described earlier). One of the following three events occur after a query from the master.

1. Normal response.

The slave has received the query without communication error and can handle the query normally. The slave returns a normal response.

2. Communication error.

If the slave does not receive the query due to a communication error, or detects some communication error (parity error or checksum error), **no** response is returned. The master should process a time-out for the query.

3. Command error.

If the slave receives the query without any communication error, but cannot handle the query, e.g. if the command was not valid, the requested register number not valid or AST 3IS in a mode where the command was not allowed, then the slave will return an exception response informing the master of the nature of the error.

The following exception codes are possible.

Code	Name	Description
01	Illegal function	Not a valid function code. Valid function codes are 01, 02, 03, 05, 06, 08, 15, 16.
02	Illegal data address	Not a valid data address. See 'Register description - Process parameters' for a list of allowed registers.
03	Illegal data value	Value in data query field not valid. To get a better explanation of the error, the 'command error' register could be read.
07	Negative acknowledge	AST 3IS has received the query but cannot perform it. To get a better explanation of the error, the 'command error' register could be read.

Set-up registers

Set-up registers data area

All set-up parameters are saved in float format and can be read and manipulated by a remote master. Two different types of float formats are supported, which one you should use depends on your Modbus master. To be able to edit the parameters a Coil must first be set to enter set-up remote state.

Note: Normally the Windows programme deltaCOM, supplied by Nobel Weighing Systems, is used to edit parameters from a remote computer, and therefore this information is only useful if you are writing your own set-up program on your master computer. Consult chapter 3 for explanation and location of each set-up parameter.

Register area Float	Register area Modicon float	Description	R/W
40380	45380	First normal set-up register (normally 41000). If 'Modicon float' is used, add 5000 to this value.	R
40382	45382	Number of normal set-up registers.	R
40384	45384	First application programme specific set-up register. If 'Modicon float' is used, add 5000 to this value.	R
40386	45386	Number of application specific set-up registers (normally 0).	R
40388	45388	Start of special set-up registers (used for diagnostic purposes).	R
40390	45390	Number of special set-up registers (used for diagnostic purposes).	R
40394	45394	Set-up version.	R
40396	45396	Set-up data version.	R
41000 – 41700	46000 – 46700	Set-up registers. Register area containing the set-up registers. See chapter 3 for an explanation of the different parameters.	R/W

How to edit set-up registers

Example: Change resolution to 0.2.

- Start by setting coil 100 'Enter Remote Set-up'.
- Locate the resolution parameter in chapter 3. This gives modbus register 41056.
- Set resolution '0.2' by sending '7' to modbus register '41056'.
- Proceed with changes of all the parameters that are to be changed.
- Finish by setting coil 102 'Exit Remote Set-up/Restore and save changes'.
- The AST 3IS makes a reset and the changes goes in action.

External display

If the choice 'External display' is selected for parameter 'Serialport mode', the serial port on the AST 3IS can be used for presentation of the weight on an external display unit. The transmitted weight is adapted for Newport/London large digit indicators with 4, 5, 6 or 7 digits and the Intrinsic safety indicator BA488C with 32 characters, connected via the MTL5051 serial communications isolator. To get a working remote display the parameters 'Baudrate', 'Data format' and 'Ext. disp.format' must be set to those defined by the remote display.

In the set-up parameter 'Ext disp.format' the following formats for the transmitted weight value can be selected:

Type	Description
4 digits	Four digit indicator. Display: -999 – 9999 (plus possible decimal point).
5 digits	Five digit indicator. Display: -9999 – 99999 (plus possible decimal point).
6 digits	Six digit indicator. Display: -99999 – 999999 (plus possible decimal point). Possible gross/net indicators will be activated. (GROSS ONLY ON AST 3IS).
7 digits	Seven digit indicator. Display: -999999 – 9999999 (plus possible dec. point).
32 characters	BA488C Intrinsic safety indicator. Display: -999999 – 9999999 (plus possible dec. point).

Remote display with 4 to 7 digits

The remote display normally shows the current weight, but under the following conditions only 'dashes' (-----) are displayed:

- the number of digits in the transmitted weight value is outside the indicators range.
- the instrument is not in normal state or there is a weight error.

Definition of weight value to large digit indicator 4, 5, 7 digits:

Character No.	Value alphanumeric.	Value Hex	Function
1		02	Start character (STX)
2 to 5 – 9	0 – 9, ., -	30 – 39, 2E, 2D	* / Weight value: 4, 5 or 7 digits and a possible decimal point. (The first digit may be a minus sign).
Last		0D	End character (CR).

Definition of weight value to large digit indicator 6 digits:

Character No.	Value alphanumeric.	Value Hex	Function
1		02	Start character (STX)
2	H, blank	48, 20	This character is present only if 6 digits is selected in 'Ext. disp,format'. H = Left led ON, blank = led's OFF.
3 to 8 or 9	0 – 9, . , -	30 – 39,2E,2D	*/ Weight value: 6 digits and a possible decimal point. (The first digit may be a minus sign).
Last		0D	End character (CR)

Note: */ The number of digits in the weight value (including a minus sign, if present) will equal the number of digits selected in 'Ext. disp.format'. Leading zeros will be added to fill up to the selected number of digits. The decimal point does not occupy any digit position.

Remote display BA488C

This remote display must be connected via the MTL5051 serial communications isolator. It can handle both digits and characters and has therefore some special extra features. The weight is always shown with the chosen unit.

7. Troubleshooting

General

AST 3IS has an automatic error checking facility. This serves to facilitate troubleshooting and to ensure that the instrument will function in the best possible manner. The error checking provides a guidance on how to deal with the fault or error.

When an error occurs, the signal 'In process' will be off, the relays will be deactivated, the analogue output will be set to 0 V / 0 mA, and an error code will be formed that can be fetched by Modbus communication to a connected control unit. At the control unit the program may present an error description corresponding to the error code.

For an AST 3IS instrument, some error codes will cause messages to be displayed, containing the kind of error, the error code and hints on how to correct the error.

Error codes

The error codes are divided in four groups, depending on their origin:

- **Weight errors**, occur when transducer signals or output values go out of given ranges.
- **Start-up errors**, occur only during start-up.
- **General errors**, usually occur due to faulty entries from the front panel, alternatively invalid data or unallowed commands from the control unit.
- **Set-up errors**, can only occur during instrument set-up (from the front panel or by serial communication).

On the following pages a summary of all error codes is given (note that code 000 always means 'no error').

Weight errors

The indication is either temporary or stays on until the cause is cured.
At AST 3IS the text within " " is scrolled while the error code is displayed.

Error code	Explanation
000	No error. The instrument in operating state and no error is detected.
001	Instrument in Remote set-up state. Weight is not valid.
003	Instrument not in normal state. Weight is not valid.
005	Ovrange error. " Reduce the load on the transducer(s) " Ovrange means that the input signal from the transducer exceeds the operating range.
007	Underrange error. " Transducer signal below allowed range " Underrange means that the input signal from the transducer is below the operation range.
010	Excitation short-circuit. " Check connections " Either a short-circuit in the excitation circuit or too many transducers connected. (A fault in a transducer or inside the signal transmitter is also possible.) Check transducer connections. See section, 2 Installation.
011	Sense voltage error. " Check connections " The sense voltage is too low, unbalanced or has a reversed polarity. (A fault in a transducer or inside the signal transmitter also possible.) Check transducer connections. See section, 2 Installation.
012	Transducer sign. error. " Check connections " The input signal is too high, for example due to a faulty or missing transducer connection. (A fault in a transducer or inside the signal transmitter is also possible.) Check transducer connections. See section, 2 Installation.
013	TransducerSignal out of range. The input signal is too high. (A fault in accordance with Error 012 above is also possible.)
015	TransducerSignal out of range. The input signal is too low. (A fault in accordance with Error 012 above is also possible.)

Start-up errors

These error codes can only appear during start-up.

Error code	Explanation
080	<p>Invalid set-up version. This error usually occurs at first start-up after a program upgrade. The actual settings have been replaced by default values. Enter set-up mode, perform the necessary editing and save the new parameter settings.</p>
081	<p>Invalid set-up data. Indicates faulty parameter checksum. The actual settings have been replaced by default values. Enter set-up mode, perform the necessary editing and save the new parameter settings.</p>
083-085	<p>Invalid factory calibration. Invalid factory calibration is a fatal error. It indicates that the range constant stored in the EEPROM during manufacture has been corrupted. Specially trained service personnel is required. The distributor must be contacted.</p>
097	<p>RAM error. RAM memory error is a fatal error. It indicates equipment failure which requires trained service personnel. The distributor must be contacted.</p>
098	<p>FLASH error. Flash memory error is a fatal error. It indicates equipment failure which requires trained service personnel. The distributor must be contacted.</p>
099	<p>Watchdog error. If a watchdog error appears the system will be reinitialised. The operator must then send a reset command from the control computer, or power the instrument off and on, to achieve normal operation. The program regularly sends impulses to a special watchdog circuit to ensure that the circuits and the program operate correctly. However, if these impulses for any reason are omitted the watchdog error indication will result.</p>

General errors

These errors generally occur due to faulty entries from the front panel, alternatively invalid data or unallowed commands from the control unit.

Error code	Explanation
100	Instrument in wrong state. The transmitted command is not applicable to the present AST 3IS mode.
101	Overrange entry. Value over allowed range. Compare with restrictions for the parameter.
102	Underrange entry. Value under allowed range. Compare with restrictions for the parameter.
103	Illegal start address. When writing float values or set-up values the start address of the written data must be even.
104	Illegal number of registers. When writing float values the number of registers of the written data must be even. This error can also occur when writing scaled integer values.
105	Illegal value error. When using scaled integer format the number of decimals must be less than 8.
130	Enter set-up/restore not allowed. The transmitted command is not applicable to the present AST 3IS mode.
131	Exit set-up/restore not allowed. The exit set-up command is only allowed when the instrument state is "Remote set-up state" or "Remote restore state".

Set-up errors

These errors occur only during instrument set-up, from the front panel or by serial communication.

Certain errors depends on more than one set-up parameter and it is the operator's responsibility to locate and correct all faulty set-up parameters.

Error codes 179 – 192 occur when it is not allowed to exit remote set-up or remote restore because of faulty parameter values.

Error code	Explanation
160	Calibration weight error. Weight error during calibration.
162	Calibration timeout error. Transducer signal is not stable within 10 seconds during calibration.
163	Saving of set-up value not allowed. Certain set-up parameters are dependent on other parameters and saved automatically when you save a new value for the related set-up. Thereafter, certain automatically saved parameters can only be browsed. If you try to save a new value in one of these set-ups this indication will result.
164	Illegal set-up register. Requested set-up parameter does not exist or is not defined.
165	Too many digits. The Capacity value has more than the permitted 6 digits. Select a combination of Resolution and Capacity that will result in max. 6 digits plus decimal point.
179	Bandwidth mismatch. The ratio between analogue and digital bandwidth must not exceed 100. Example: 0.1 Hz ↔ 10 Hz.
188	Too many digits. The Capacity value has more than the permitted 6 digits. Select a combination of Resolution and Capacity that will result in max. 6 digits plus decimal point.
189	Too high transducer signal in cal. point 2. The mV/V signal in calibration point 2 is too high (often due to a previous, strange data sheet calibration).
190	Too high transducer signal in cal. point 2. The mV/V signal in calibration point 2 is too high, due to strange data sheet calibration. The conversion factor, rated load etc. does not correspond to each other.
191	Illegal calibration direction. Increasing transducer signal must correspond to increasing weight value.
192	Illegal analogue range high/low. Parameter value 'Ana. range high' / 'Ana. range low' out of allowed range.
41000 - 41900	Exit Remote Set-up/Restore not allowed. There is an error in the parameter pointed out by this error code. The parameter value is out of range.

Set-up list for AST 3IS Address:

Location/Notes:

Progr. name: Ser. no.: Date:

Modbus number	Parameter name	Default value	Set-up value	
41000	Level 1 source	Not in use [0]
41002	Level 1 value	0.0
41004	Level 1 hyst.	0.0
41006	Relay 1 source	In process [1]
41008	Level 2 source	Not in use [0]
41010	Level 2 value	0.0
41012	Level 2 hyst.	0.0
41014	Relay 2 source	Not in use [0]
41016	Language	English [1]
41018	Start mode	Auto [1]
41020	Display contrast	4 [4]
41022	Zero function	Off [0]
41024	More views	Off [0]
41026	Security lock	Off [0]
41028	Password	1937
41030	Ana. output type	4–20mA [3]
41032	Ana. range low	0.0
41034	Ana. range high	500.0
41036	Fixed ana. outp.	0.00
41038	Ana. bandwidth	10 Hz [7]
41040	Ana. low adjust	0
41042	Ana. high adjust	0
41044	Serialport mode	Modbus auto [2]
41046	Baudrate	9600 [5]
41048	Data format	8-none-1 [5]
41050	Instrum. address	1
41052	Ext. disp.format	6 [2]
41054	Measurement unit	kg [2]
41056	Resolution	0.1 [6]
41058	Capacity	500.0
41060	Mains frequency	50 Hz [0]
41062	Dig. bandwidth	10 Hz [7]
41064	Calibration type	Data sheet [0]

Set-up list for AST 3IS Address:

Location/Notes:

Progr. name: Ser. no.: Date:

Modbus number	Parameter name	Default value	Set-up value	
41066	Conv. factor	9.80665
41068	Number of transd	3
41070	Rated load	2000.0
41072	Rated output 1	2.03900
41074	Rated output 2	2.03900
41076	Rated output 3	2.03900
41078	Rated output 4	2.03900
41080	Value cal. p.1	0.0
41082	Value cal. p.2	500.0
41084	Transd.sign. p.1	0.00000
41086	Transd.sign. p.2	1.66631
41090	Zero offset	0.00

Appendix 1.

Set-up list.

Declaration of Conformity

We Vishay Nobel AB
Box 423, S-691 27 KARLSKOGA
SWEDEN

declare under our sole responsibility that the product

Analogue Signal Transmitter AST 3IS
from serial nr. 2002-0001

to which this declaration relates is in conformity with the
following standards or other normative documents

The essential requirements in the EMC Directive 89/336/EEC
with amend. 92/31/EEC and 93/68/EEC.

EN 61 326

The essential requirements in the ATEX Directive 94/9/EC
with later amendments

EN 50 014 : 1997 + Amendments 1 & 2
EN 50 020 : 2002

EC – Type examination Certificate: Baseefa02ATEX0053
Notified body for CENELEC/ATEX: Baseefa(2001) Ltd. 1180

The product is supplied by 24 VDC and is therefore not covered by
the requirements in the Low Voltage Directive 73/23/EEC

KARLSKOGA Jan 17 2003.....

Bengt Schultz, Managing Director

Certificate Number
Baseefa02ATEX0053



Issued 14 November 2002
Page 1 of 3

-
- 1 **EC - TYPE EXAMINATION CERTIFICATE**
- 2 **Equipment or Protective System Intended for use in Potentially Explosive Atmospheres**
Directive 94/9/EC
- 3 EC - Type Examination Certificate Number : **Baseefa02ATEX0053**
- 4 Equipment or protective system: **AST 3IS**
- 5 Manufacturer : **Thermo Nobel AB**
- 6 Address : **Box 423, SE-691 27 Karlskoga, Sweden**
- 7 This equipment and any acceptable variation thereto is specified in the schedule to this certificate and the documents therein referred to.
- 8 Baseefa (2001) Ltd. Notified body number 1180 in accordance with Article 9 of the Council Directive 94/9/EC of 23 March 1994, certifies that this equipment or protective system has been found to comply with the Essential Health and Safety Requirements relating to the design and construction of equipment and protective systems intended for use in potentially explosive atmospheres given in Annex II to the Directive.
- The examination and test results are recorded in confidential Report No. **02(C)0254**
- 9 Compliance with the Essential Health and Safety Requirements has been assured by compliance with:
EN 50014 : 1997 + Amendments 1 & 2 EN 50020 : 2002
except in respect of those requirements listed at item 18 of the Schedule.
- 10 If the sign "X" is placed after the certificate number, it indicates that the equipment or protective system is subject to special conditions of safe use specified in the schedule to this certificate.
- 11 This EC - TYPE EXAMINATION CERTIFICATE relates only to the design and construction of the specified equipment or protective system. If applicable, further requirements of this Directive apply to the manufacture and supply of this equipment or protective system.
- 12 The marking of the equipment or protective system shall include the following :
- ⊕ II (1) GD [EEex ia] IIC -10°C ≤ Ta ≤ +40°C**
- This certificate may only be reproduced in its entirety, without any change, schedule included.

Baseefa (2001) Ltd. Customer Reference No. **2054**

Project File No. **02/0254**

This certificate is granted subject to the general terms and conditions of Baseefa (2001) Ltd. It does not necessarily indicate that the equipment may be used in particular industries or circumstances.

R S SINCLAIR
DIRECTOR
On behalf of
Baseefa (2001) Ltd.

Baseefa (2001) Ltd.
Health and Safety Laboratory Site, Harpur Hill,
Buxton, Derbyshire SK17 9JN
Telephone +44 (0) 1298 28255 Fax +44 (0) 1298 28216
e-mail info@baseefa2001.biz web site www.baseefa2001.biz
Registered in England No. 4305578 at 13 Dovedale Crescent, Buxton,
Derbyshire, SK17 9BJ



Schedule

15 Description of Equipment or Protective System

The AST 3IS is a transformer isolated analogue signal transmitter designed to provide a galvanically isolated interface to enable the connection of 4 or 6-wire load transducers located in a hazardous area to apparatus located in a non-hazardous area by providing galvanic isolation and limiting the voltage and current into the hazardous area to intrinsically safe levels.

The apparatus comprises a number of electrical components, including transformers, fuses, resistors and zener diodes, mounted on three printed circuit boards and housed within a plastic enclosure.

The segregation of the hazardous area circuits meets the requirements for 375V pk.

Non-hazardous Area Terminals 9 to 25:

$$U_m = 250V$$

The AST3IS is designed to be powered from a dc supply not exceeding 32V (Terminals 17, 18).

Relay contacts on terminals 9 to 14 to be connected to an ac/dc supply not exceeding 30V and 1A.

Hazardous Area Terminals 1 to 8:

$$U_o = 14.4V \quad I_o = 600mA \quad P_o = 1.1W \quad C_i = 40nF$$

The capacitance and either the inductance or the inductance to resistance ratio (L_o/R_o) of the load connected to the output terminals of each channel must not exceed the following values:

GROUP	CAPACITANCE in μF	INDUCTANCE in μH	OR	L/R RATIO in $\mu H/ohm$
IIC	0.5	60		32
IIB	3.0	180		130
IIA	12	480		260

16 Report No.

Baseefa (2001) Ltd. Certification Report 02(C)0254 dated 14th November 2002.

17 Special Conditions for Safe Use

None

18 Essential Health and Safety Requirements

None additional to those covered by the standards listed at item 9

19 Drawings and Documents

Number	Issue	Date	Description
110 262 Sheets 1 to 3	2	07/11/02	AST 3IS Parts List
300 136	1	03/10/02	AST 3IS Assembly

Appendix 3.

Certificate Number
Baseefa02ATEX0053



Issued 14 November 2002
Page 3 of 3

Number	Issue	Date	Description
400 394	0	06/04/99	Display PCB
400 395	0	06/05/99	CPU PCB
400 396	0	05/05/99	Power PCB
400 402	0	08/06/99	Power PCB Assembly C side
400 403	0	08/06/99	Power PCB Assembly S side
400 404	0	08/06/99	CPU PCB Assembly C side
400 405	0	08/06/99	CPU PCB Assembly S side
500 465	0	16/12/98	Hazardous Area Terminals Ident
500 466	0	19/05/99	IS Transformer
500 467	0	17/12/98	Non-Hazardous Area Terminals Ident
500 470	1	03/03/99	Heatsink
500 531	0	18/12/98	Display Circuit
500 532	0	11/12/98	CPU Circuit Sheet 1
500 533	0	18/12/98	CPU Circuit Sheet 2
500 534	0	18/12/98	CPU Circuit Sheet 3
500 535	0	18/12/98	CPU Circuit Sheet 4
500 536	0	18/12/98	CPU Circuit Sheet 5
500 537	0	18/12/98	CPU Circuit Sheet 6
500 538	0	18/12/98	CPU Circuit Sheet 7
500 539	2	14/11/02	Power Circuit Sheet 1
500 540	0	11/12/98	Power Circuit Sheet 2
500 541	0	11/12/98	Power Circuit Sheet 3
500 542	1	11/12/98	Power Circuit Sheet 4
500 547	0	06/04/99	Display PCB Assembly
500 550	0	10/04/99	Heat sink
500 593	0	08/06/99	IS Transformer Assembly
500 991	2	03/10/02	Label
600 617	0	07/08/02	Serial no Label
850 046 Sheets 1 and 2	0	14/11/02	Critical Parts List

This certificate may only be reproduced in its entirety and without change, schedule included.

Document no. 35166
Article no. 600 619 R4
© Vishay Nobel AB, 2011-06-27
Subject to changes without notice.

Vishay Nobel AB
Box 423, SE-691 27 Karlskoga, Sweden
Phone +46 586 63000 · Fax +46 586 63099
pw.se@vishaypg.com
www.weighingsolutions.com