



---

**BLH**

**MODEL 325**  
**Weigh Systems Calibrator**  
**Operator's Manual**

TM026  
RevC  
6/1/11  
Doc 35120

## **NOTICE**

BLH makes no representation or warranties of any kind whatsoever with respect to the contents hereof and specifically disclaims any implied warranties or merchantability or fitness for any particular purpose. BLH shall not be held liable for errors contained herein or for incidental or consequential damages in connection with the furnishing, performance, or use of this publication or its contents.

BLH reserves the right to revise this manual at any time and to make changes in the contents hereof without obligation to notify any person of such revision or changes.

Call (781) 298-2216 for BLH Field Service.

## Table of Contents

SECTION 1. Introduction .....	1-1
1.1 GENERAL .....	1-1
1.2 SPECIFICATIONS .....	1-1
1.3 WARRANTY POLICY .....	1-1
1.4 FIELD ENGINEERING .....	1-2
SECTION 2. Installation .....	2-1
2.1 GENERAL .....	2-1
2.2 LOCATION .....	2-1
2.3 ELECTRICAL INSTALLATION.....	2-1
2.3.2 Remote Sense Lead Connections.....	2-1
2.3.3 Signal Connections .....	2-2
SECTION 3. Operation .....	3-1
3.1 GENERAL .....	3-1
3.2 FRONT PANEL CONTROL.....	3-1
3.2.1 Millivolt-Per-Volt Selection.....	3-1
3.2.2 Input/Output Resistance Selection .....	3-1
3.2.3 Vernier Adjustment.....	3-2
3.3 CALIBRATION .....	3-2
3.3.1 Dead Weight Signal Calibration .....	3-2
3.3.2 Establishing Zero .....	3-2
3.3.4 Calculate the Interpolated Span Value.....	3-3
3.3.5 Entering a Span Point .....	3-3
3.4 VERNIER OPERATION .....	3-3

## SECTION 1. Introduction

### 1.1 GENERAL

The Model 325 precision calibrator (Figure 1-1) is a portable, lightweight simulator designed to supply high accuracy millivolt-per-volt (mV/V) level signals for testing and calibrating weigh system instrumentation. Precise output references for 0, 0.5, 1, 1.5, 2, 2.5, 3, and 3.5 mV/V are achieved by using a metal film resistor network, discrete wire wound resistors, and a 2-pole, 8-position rotary switch. The 350, 700, and 1000 ohm input and output impedance selections match typical strain gage devices. Vernier operation provides precise checking of setpoint and alarm functions. Four permanent binding posts, integral to the rugged palm-size case, provide connection points for the indicator or transmitter.



Figure 1-1. The Model 325

The Model 325 unit substitutes for weigh system transducers. Lightweight construction, compact size, and superb accuracy make the Model 325 Calibrator an excellent choice for calibrating process weighing instruments and transmitters.

### 1.2 SPECIFICATIONS

Output Accuracy	0.02% of selected range
Accuracy Stability	
(0.5 and 1mV/V steps)	less than 0.01% in 24 hours less than 0.02% in 1 year
(1.5 thru 3.5 mV/V steps)	less than 0.005% in 24 hours less than 0.01% in 1 year
Zero Stability	less than 3 uV
Span TC	+ /- 15 ppm/degree C
Input Impedance (Excitation)	adjustable to + /- 0.05%
Output Impedance (Signal)	adjustable to + /- 0.08%
Output Ranges	8 steps: 0, 0.5, 1, 1.5, 2, 2.5, 3 and 3.5 mV/V
Vernier Range	106% (approx.) of selected step
25Vdc maximum	25Vdc maximum
Operating Temperature Range	32 to 120 F (0 to 50C)
Impedance Adjustment	350, 700, and 1000 ohms
Dimensions (inches)	6 x 32 x 1.8 (LVVH)

### 1.3 WARRANTY POLICY

BLH warrants the products covered hereby to be free from defects in material and workmanship. BLH's liability under this guarantee shall be limited to repairing or furnishing parts to replace, f.o.b. point of manufacture, any parts which, within three (3) years from date of shipment of said product(s) from BLH's plant, fail because of

defective workmanship or material performed or furnished by BLH. As a condition hereof, such defects must be brought to BLH's attention for verification when first discovered, and the material or parts alleged to be defective shall be returned to BLH if requested. BLH shall not be liable for transportation or installation charges, for expenses of Buyer for repairs or replacements or for any damages from delay or loss of use for other indirect or consequential damages of any kind. BLH may use improved designs of the parts to be replaced. This guarantee shall not apply to any material which shall have been repaired or altered outside of BLH's plant in any way, so as in BLH's judgment, to affect its strength, performance, or reliability, or to any defect due in any part to misuse, negligence, accident or any cause other than normal and reasonable use, nor shall it apply beyond their normal span of life to any materials whose normal span of life is shorter than the applicable period stated herein. In consideration of the forgoing guarantees, all implied warranties are waived by the Buyer, BLH does not guarantee quality of material or parts specified or furnished by Buyer, or by other parties designated by buyer, if not manufactured by BLH. If any modifications or repairs are made to this equipment without prior factory approval, the above warranty can become null and void.

#### **1.4 FIELD ENGINEERING**

Authorized BLH Field Service Engineers are available around the world to install and/or repair BLH products. The field service department at BLH is the most important tool to assure the s best performance from your application. Field service phone numbers are listed below.

**Factory: (Main Number) (781) 298-2200**

**(800) 567-6098 in Canada**

## SECTION 2. Installation

### 2.1 GENERAL

The Baldwin Model 325 calibrator is a hand-held device and requires no mechanical installation instructions. Figure 2-1 provides outline dimensions for reference and storage considerations.

### 2.2 LOCATION

Units perform accurately in temperatures ranging from 32 to 120 degrees Fahrenheit. If used in harsh or dirty environments, wipe clean before storing. When not in use, store in a clean, dry, vibration free area that is exempt from unusual temperature fluctuations.

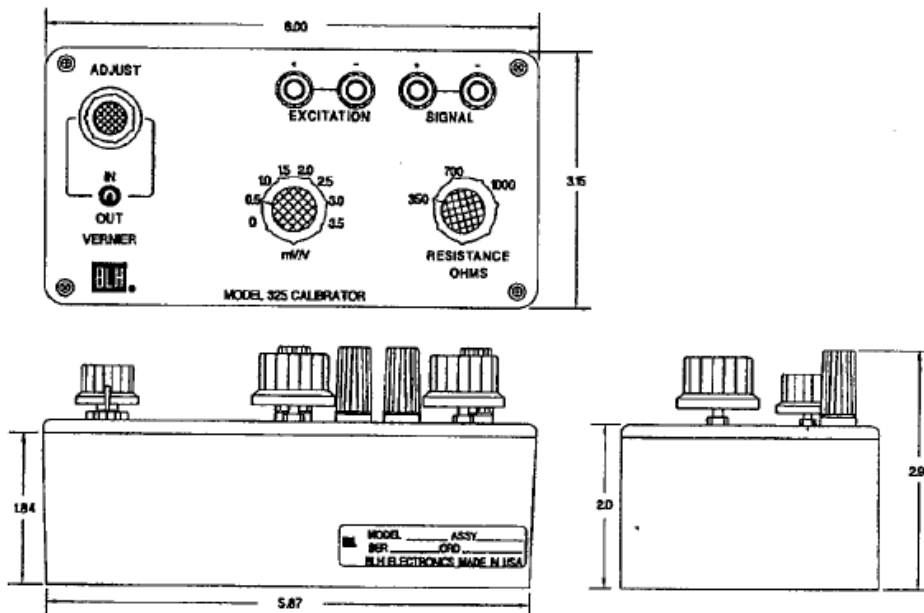

Figure 2-1. Model 325 Outline Dimensions

### 2.3 ELECTRICAL INSTALLATION

#### 2.3.1 Excitation Lead Connections

Power for the 325 is supplied by the instrument (indicator, transmitter, etc.) being tested. Simply connect the instrument excitation output to the 325 excitation input binding posts as shown in Figure 2-2 (black and green leads).

#### 2.3.2 Remote Sense Lead Connections

For maximum calibration accuracy on systems equipped with remote sense lines, connect those leads in parallel with the excitation leads on the green and black binding posts.

### 2.3.3 Signal Connections

Simply connect the leads for the input of the indicator/transmitter to the red and white binding posts as shown in Figure 2-2.

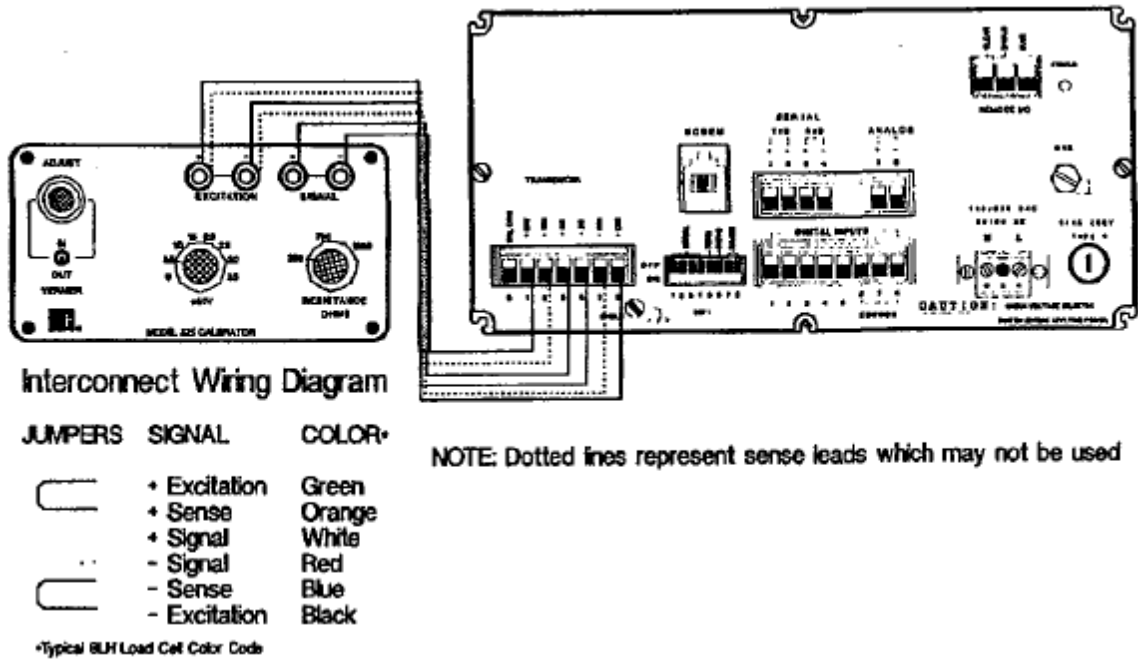

**Figure 2-2. Typical Electrical Connections**

NOTE: The Model 325 polarity designations are designed to simulate compression type systems. To simulate a tension system, the signal leads (white and red) may have to be reversed.

NOTE: BLH load cell wiring color code conventions may differ from other load cell manufacturers.

## SECTION 3. Operation

### 3.1 GENERAL

The Model 325 Calibrator is a multi-purpose tool designed to simulate ' scale/system transducers when calibrating system instrumentation. After completing SECTION II installation instructions, the 325 calibrator is ready for operation.

### 3.2 FRONT PANEL CONTROL

Front panel controls consist of an 8-position rotary switch (Figure 3-1) for selecting mV/V simulation, a 3-position rotary switch for selecting input and output resistance, and a 2-position bat-handle switch/potentiometer combination for vernier adjustments.

#### 3.2.1 Millivolt-Per-Volt Selection

Use the 8-position rotary switch to select 0, 0.5, 1.0, 1.5, 2.0, 2.5, 3.0, and 3.5 mV/V output ranges. Each range supplies a highly accurate, constant output.

#### 3.2.2 Input/Output Resistance Selection

The 3-position resistance-ohms selection switch provides 3 resistance ranges to match different transducer specifications. Traditional strain gage based transducers typically specify 350 ohm impedance values. However, some beam style transducers may use 700 or 1000 ohm gages. Consult the transducer specification sheet or installation instructions for the correct value and select accordingly.

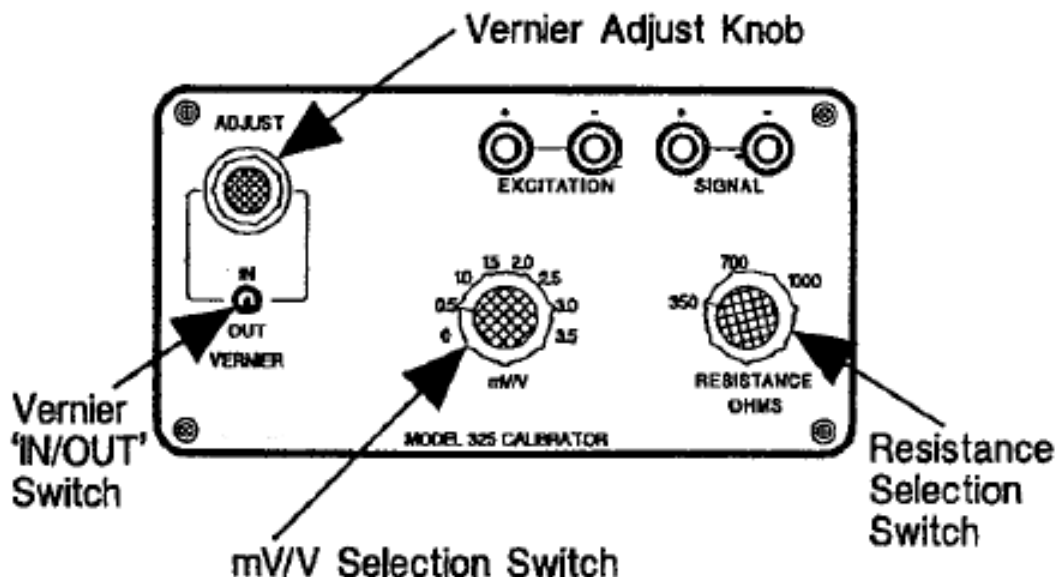

Figure 3-1. Model 325 Front Panel Controls.



### **3.2.3 Vernier Adjustment**

The Model 325 Calibrator offers a vernier adjustment for checking setpoint, peak/hold, alarm, and overrange instrument functions (see paragraph 3.4). The bat-handle switch must be in the 'IN' position for vernier function. As specified in paragraph 1.2, the vernier functions over 106% of the selected step range (slightly more than 0.5 mV/V).

### **3.3 CALIBRATION**

The typical procedure for calibrating a transducer indicating/transmitting instrument is to apply known input mV/V levels and adjust the instrument to display the correct equivalent value in engineering units such as lb, kg, etc.. For example, when 0 mV/V is selected the instrument display should read 0 pounds. If the indicator does not read 0 pounds at 0 mV/V, adjust the instrument zero selector (consult instrument operator's manual for instructions) until the readout is correct. If the system/platform rated capacity is 10,000 pounds at 2 mV/V, setting the 325 simulator switch to 2 mV/V should result in a 10,000 pound display. If the indicator does not read 10,000 pounds at 2 mV/V, adjust the instrument span selector (consult instrument operator's manual for instructions) until the readout is correct.

If the system full scale rated output is 2 mV/V, midrange linearizing calibration adjustments can be made by selecting 0.5, 1, and 1.5 mV/V steps and adjusting the readout to display 25, 50, and 75% of capacity (re-check 0 and full scale displays afterwards). Similarly, for a 3 mV/V system, linearizing adjustments can be made at 0.5, 1, 1.5, 2, and 2.5 mV/V.

#### **3.3.1 Dead Weight Signal Calibration**

With newer BLH indicators/transmitters it is not necessary to initially calibrate out the load cell output corresponding to dead load, or empty vessel weight. This step will normally be accomplished by simply re-acquiring a new calibrated zero value on the system after the live load calibration is complete.

#### **3.3.2 Establishing Zero**

To establish zero, perform the following:

1. Select 0 mV/V on the 325 calibrator.
2. Adjust the indicator/transmitter to zero and/or output a value corresponding to zero (i.e. set 4-20 mA output to 4 mA).

3.3.3 Calculate the Live Load mV/V Signal

The next requirement is to determine the live load mV/V signal (portion of the load cell output corresponding to actual product weight). Use the formula presented in Figure 3-2 to determine this value.

$$\text{Live Weight} \frac{\text{mV}}{\text{V}} \text{ Signal} = \frac{\text{Live Weight}(\text{Product Weight})}{\text{System Capacity (Total Weight)}} \times \text{Full Transducer Output} \left( \frac{\text{mV}}{\text{V}} \right)$$

**Figure 3-2. Live Weight Signal Calculation Formula**

### 3.3.4 Calculate the Interpolated Span Value

Since the 325 has only 8 discrete settings, establishing a live load span point typically requires an interpolation process to determine a new span point value corresponding to one of the fixed mV/V values. Use the formula shown in Figure 3-3 to determine this value. When interpolating always choose a Model 325 mV/V selection lower than the full transducer output value.

Interpolated Span Value

$$= \frac{\text{Nearest Lower Model 325} \frac{\text{mV}}{\text{V}} \text{ Selection}}{\text{Calculated Live Weight} \frac{\text{mV}}{\text{V}} \text{ Signal}} \times \text{Live Weight (Product Weight)}$$

**Figure 3-3. Span Value Interpolation Formula**

### 3.3.5 Entering a Span Point

To enter the span point, perform the following:

1. Select the desired 325 mV/V setting.
2. Acquire and adjust the span point in the indicator/transmitter (refer to the indicator/transmitter instruction manual).

Calibration functions described in this chapter pertain to digital indicator/transmitters that can acquire a dead weight zero in place. Analog indicators may require a different procedure (consult operator's manual supplied with unit).

NOTE: Make sure the instrument is in gross mode with all automatic functions turned OFF and the vernier adjustment 'OUT before attempting calibration.

NOTE: After the weighing system is re-connected to the instrument, simply perform acquire zero before beginning operation.

## 3.4 VERNIER OPERATION

The Model 325 calibrator is equipped with a vernier adjustment for checking setpoint, peak/hold, alarm, and overrange instrument functions. Since normal operation advances in 0.5 mV/V increments, it is difficult to verify exact setpoint cutoff points without the vernier. With vernier operation selected, the indicator can be incremented count by count and precise status change points determined or confirmed. To use the vernier function, perform the following:

1. Advance the 325 mV/V selection switch to the nearest value below anticipated cutoff. If necessary, use the interpolation tables described in paragraphs 3.3.3 and 3.3.4 to determine the correct selection.
2. Change the vernier adjustment bat-handle switch to the 'IN' (on) position.
3. Observing the indicator display, rotate the potentiometer switch until the point of coincidence is achieved.



3 Edgewater Drive  
Norwood, MA 02062 USA  
Phone (781) 298-2200  
Fax (781) 762-3988

[www.vishaypg.com](http://www.vishaypg.com)