



**VISHAY
PRECISION
GROUP**

BLH

HTU Web Tension Transducer Installation Instructions

TM044
RevC
6/1/11
Doc 35128

Table of Contents

1	Introduction	1-1
1.1	PRODUCT DESCRIPTION.....	1-1
1.2	OPTIONAL LOAD PLATES	1-1
1.3	HTU SPECIFICATIONS.....	1-2
1.4	WARRANTY POLICY	1-2
1.5	FIELD ENGINEERING SERVICES.....	1-2
2	Installation.....	2-1
2.1	GENERAL	2-1
2.2	MECHANICAL INSTALLATION	2-3
2.2.1	Pillow Block Adapter Plate Assembly.....	2-3
2.2.2	.Base Adapter Plate Assembly (Optional).....	2-3
2.2.3	Attaching the HTU Unit to the Frame/Base	2-4
2.2.4	Up-Side-Down Mounting Arrangements	2-5
2.2.5	Installing the Pillow Block.....	2-5
2.3	ELECTRICAL CONNECTIONS	2-5
2.3.1	Typical Wiring Designations.....	2-6
2.3.2	Dual Channel DXt-40 Wiring	2-6
2.3.3	Single Channel Vertical Wiring.....	2-6
2.3.4	Single Channel Horizontal Wiring	2-6
2.3.5	Shunt Resistor Installation	2-6
3	Operation	3-1
3.1	THEORY OF OPERATION	3-1
3.2	TEMPERATURE CONSIDERATIONS	3-1
3.3	FORCE DISPLACEMENT.....	3-1
4	Maintenance	4-1
4.1	CALIBRATION	4-1
4.2	TROUBLESHOOTING	4-1

1 Introduction

1.1 PRODUCT DESCRIPTION

Patented HTU Universal Load Cells (Figure 1-1) measure all forces acting upon web tension system rollers to provide the most accurate measurements available. It is not limited to horizontal or vertical force component or the load cell orientation to achieve maximum sensitivity. This permits the installation of identical load cells at multiple Web Tension zones regardless of the mounting or angle configuration of the roller.

The Model HTU is machined from high strength, corrosion resistant, stainless steel to yield a low profile single piece, metal sealed transducer that incorporates tubular sensing sections at each end. Two full Wheatstone Bridges are mounted internally to each sensor and provide output signals in the X and Y plane that are vectorially summed to determine the magnitude and direction of the resultant force F_R (Figure 1-2).

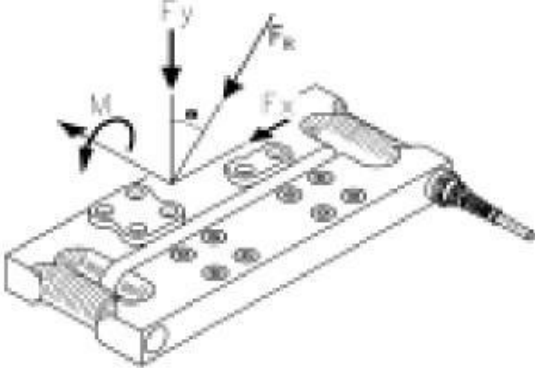

Figure 1-2. HTU Vectorial Summing

Each bridge is temperature compensated to 250°F, and dead weight calibrated to precision accuracy. The cylindrical sensing sections are sealed to meet IP67 requirements. Internal mounting of the high temperature SR-4® strain gages, combined with metal seals and integral cable conduit fitting, ensures long-term reliability for wet or washdown locations.

Retrofit installations are simplified with the ultra low profile height of 1.45" resulting in a negligible change in the line profile. The Model HTU can be mounted directly to framework with an optional pillow block adapter plate or it can accept top and bottom adapter plates. HTU load cells are calibrated and certified with matched output signals to permit on-site push button system calibration to provide minimum start-up time and maintenance-free operations.

1.2 OPTIONAL LOAD PLATES

To simplify installation procedures, BLH offers top and bottom mounting plates (Figure 1-3). The top pillow block adapter plate attaches to the pillow block bearing. A

bottom base adapter plate is mounted upon the machine frame. The HTU load cell is strategically located between the two plates for optimal measurement performance.



Figure 1-1. Model HTU Load Cell

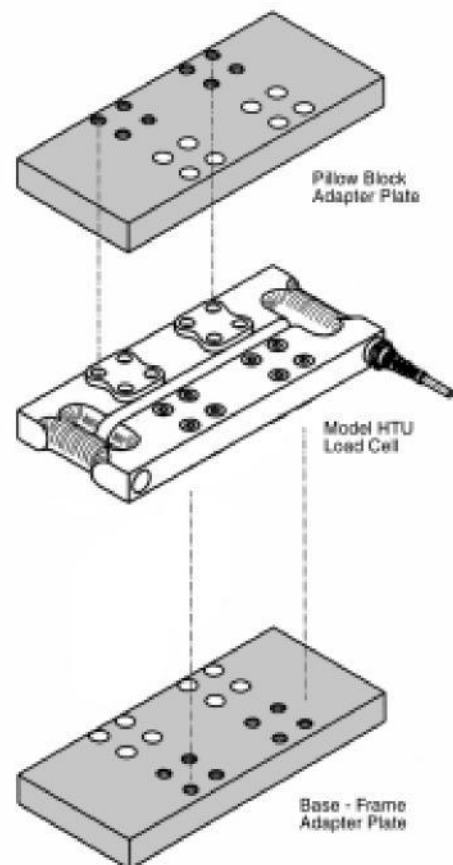

Figure 1-3. Optional Load Plates

1.3 HTU SPECIFICATIONS

Performance (% Rated Output)

Available Capacities	2K, 6K, 10K, 20K pounds
Rated Output (RO)	2.0 mV/V \pm 0.1%
Zero Balance	1.0% RO
Combined Error (best fit)	0.10% RO
Repeatability	0.02% RO
Creep (20 Minutes)	0.05% RO

Temperature

Safe Temp.	-18 to +149°C (+0 to +300°F)
Compensated Temp.	-18 to +121°C (+0 to +250°F)
Temperature Effects:	
Zero Balance	0.0044% RO/°C (0.0025%/°F)
Output- % Reading	0.0089% RO/°C (0.0050%/°F)

Overload Rating

Safe Load	150% rated capacity
Ultimate Load	300% rated capacity
Safe Sideload	100% rated capacity @12" C/L ht.

Electrical

Excitation Voltage	10 VAC-dc recommended 15 VAC-dc maximum
Input Resistance	185 \pm 10.0 ohms (both channels)
Output Resistance	500 \pm 5.0 ohms (both channels)
Connection	high temp. 6-Cond. Cable, 33 ft. 0 in.

Mechanical

Deflection	0.007 inches: 2K 0.035 inches: 6K - 20K
Weight	18 pounds, all capacities
Mounting	horizontal or vertical

Material

Beam	17-4PH stainless steel
Adapter Plates	mild or stainless steel

Moisture Protection

Rating	IEC IP67
--------	----------

1.4 WARRANTY POLICY

BLH warrants the products covered hereby to be free from defects in material and workmanship. BLH's liability under this guarantee shall be limited to repairing or furnishing parts to replace, f.o.b. point of manufacture, any parts which, within three (3) years from date of shipment of said product(s) from BLH's plant, fail because of defective workmanship or material performed or furnished by BLH. As a condition hereof, such defects must be brought to BLH's attention for verification when first discovered, and the material or parts alleged to be defective shall be returned to BLH if requested. BLH shall not be liable for transportation or installation charges, for expenses of Buyer for repairs or replacements or for any damages from delay or loss of use for other indirect or consequential damages of any kind. BLH may use improved designs of the parts to be replaced. This guarantee shall not apply to any material which shall have been repaired or altered outside of BLH's plant in any way, so as in BLH's judgment, to affect its strength, performance, or reliability, or to any defect due in any part to misuse, negligence, accident or any cause other than normal and reasonable use, nor shall it apply beyond their normal span of life to any materials whose normal span of life is shorter than the applicable period stated herein. In consideration of the forgoing guarantees, all implied warranties are waived by the Buyer, BLH does not guarantee quality of material or parts specified or furnished by Buyer, or by other parties designated by buyer, if not manufactured by BLH. If any modifications or repairs are made to this equipment without prior factory approval, the above warranty can become null and void.

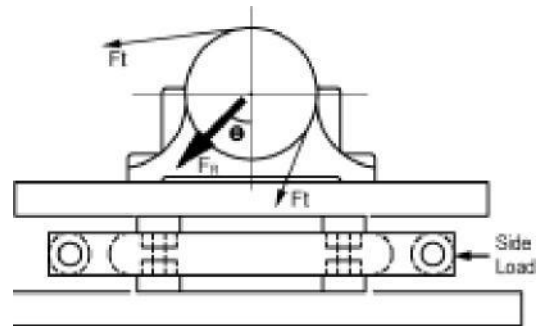

1.5 FIELD ENGINEERING SERVICES

Improper HTU installation or operation may result in equipment damage. Please follow instructions carefully. BLH will not accept any liability for faulty installation and/or misuse of this product. Authorized BLH Field Service Engineers are available around the world to install web tension systems and/or train factory personnel to do so. The field service department at BLH is the most important tool to assure the best performance from your application.

Factory:
(Main Number)
(781) 298-2200

Canada:
(416) 251-2690
Or
(800) 567-6098 toll free

2 Installation

2.1 GENERAL

This publication provides mechanical and electrical installation instructions for Model HTU Load Cells (Figure 1-1). Outline dimensions are presented in Figure 2-1 (6K - 20K) and Figure 2-1a (2K) on the next page.

IMPORTANT: BLH strongly recommends that the user read this section completely prior to starting installation as each successive step depends upon satisfactory completion of all prior procedures.

HTU Load Cells are ultra-low profile web tension transducer devices designed for simple mechanical installation. A typical unit contains a double axis output HTU Load Cell and two mounting plates. Even with both mounting plates, the profile is so low that little or no variance is introduced into web wrap angles. The load cell and optional mounting plates, which typically allows installation under existing pillow block bearings, assemble with 16 BLH supplied bolts. Eight bolts secure the HTU transducer to the base adapter plate, and eight bolts attach the pillow block retainer plate (Figure 2-2).

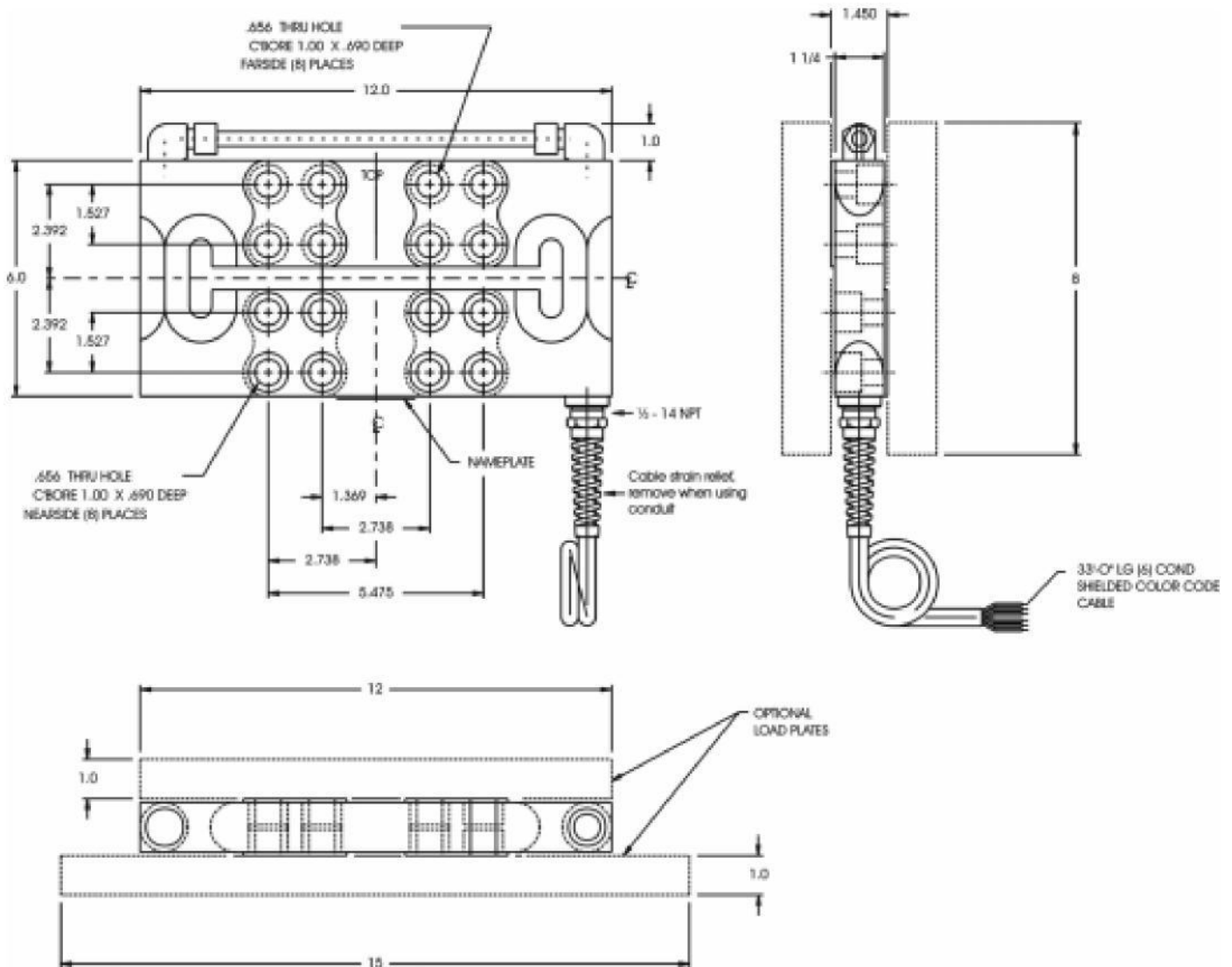
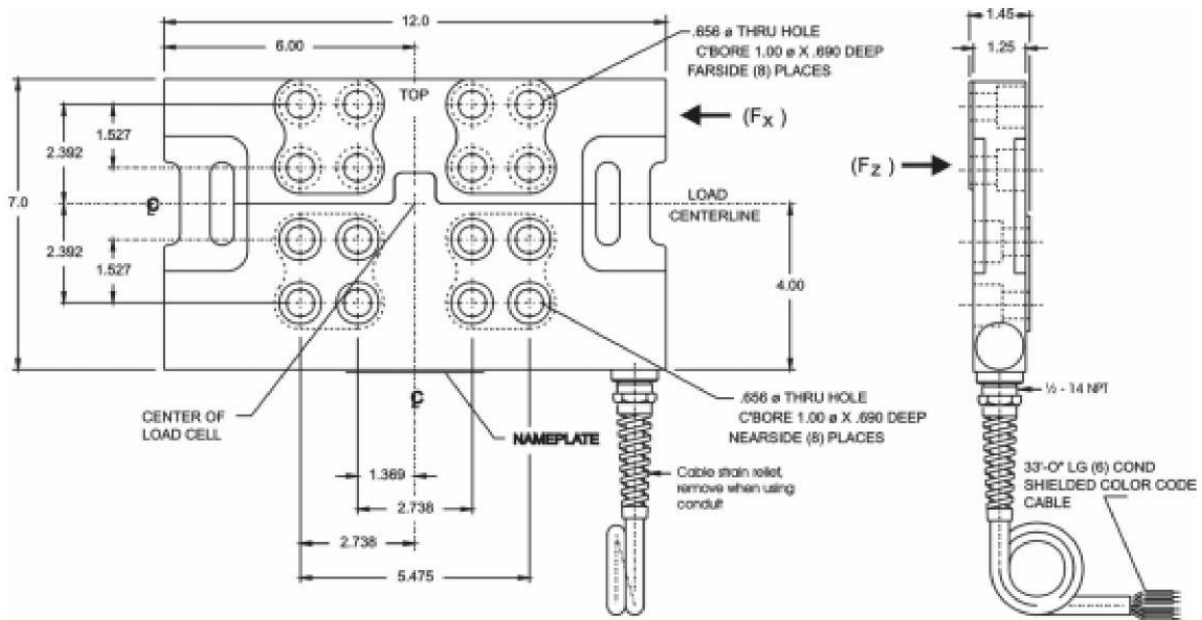

Figure 2-1. HTU Outline Dimensions, 6K to 20K Capacities



CABLE COLOR CODE

EXCITATION	{	E+	GREEN
		E-	BLACK
VERTICAL DIRECTION (F_z)	{	Z+	WHITE
		Z-	RED
HORIZONTAL DIRECTION (F_x)	{	X+	BLUE
		X-	ORANGE

Figure 2-1a. Outline Dimensions for 2K HTU Transducers

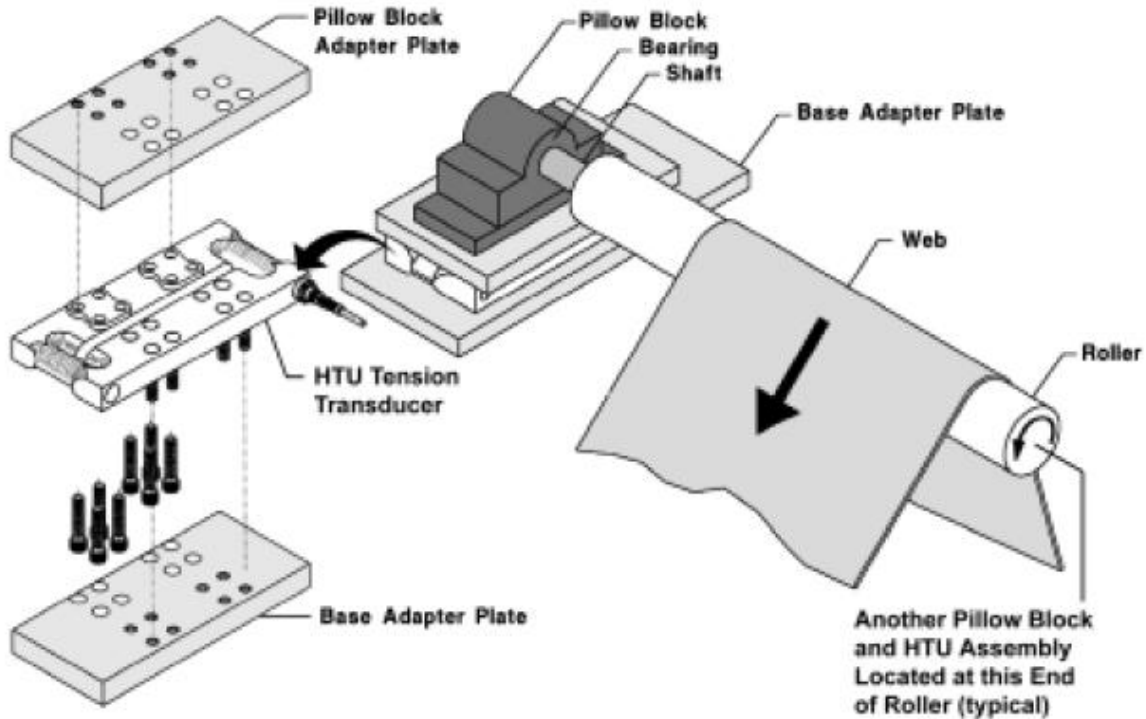

Figure 2-2. HTU Adapter Plate Assembly

2.2 MECHANICAL INSTALLATION

HTU installation instructions refer to specific components of the HTU unit. See Figure 2-2 to identify parts and part locations.

2.2.1 Pillow Block Adapter Plate Assembly

Installation begins by bolting the HTU load cell to a pillow block adapter plate (required).

1. Place the pillow block adapter plate on a clean flat surface with the threaded holes in back and the through holes forward (Figure 2-3).
2. Position the HTU Load Cell upside down (cable left) upon the pillow block adapter plate and align the bolt holes.
3. Apply thread locker (BLH P/N 147379) to the eight (8), 5/8-11UNC2Ax1^{1/2} inch long sockethead cap screws.
4. Secure the HTU to the adapter plate by tightening all eight screws until they are 'finger tight'.
5. Using the pattern shown in Figure 2-3, sequentially tighten all screws to one thousand (1000) inch-pounds.

2.2.2 Base Adapter Plate Assembly (Optional)

Although BLH recommends using a base adapter plate, HTU transducers may be mounted directly to a machine frame or other base structure. If a base adapter plate is not used go to step 2.2.3.

1. Place the base adapter plate on a clean smooth surface with the threaded holes forward (Figure 2-4).
2. Flip the HTU and adapter plate assembly over so that the cable is on the right and the pillow block adapter plate is on top.
3. Looking through the holes in the pillow block adapter plate (now on top), align the counterbored holes in the HTU with the threaded holes in the base adapter plate.
4. Apply thread locker (BLH P/N 147379) to the remaining (8), 5/8-11UNC-2Ax1^{1/2} inch socket head cap screws.
5. Insert them into the clearance holes and then thread through the HTU into the base adapter plate until finger tight.
6. Using the numeric sequence shown in Figure 2-4, torque all bolts to one thousand (1000) inch pounds.

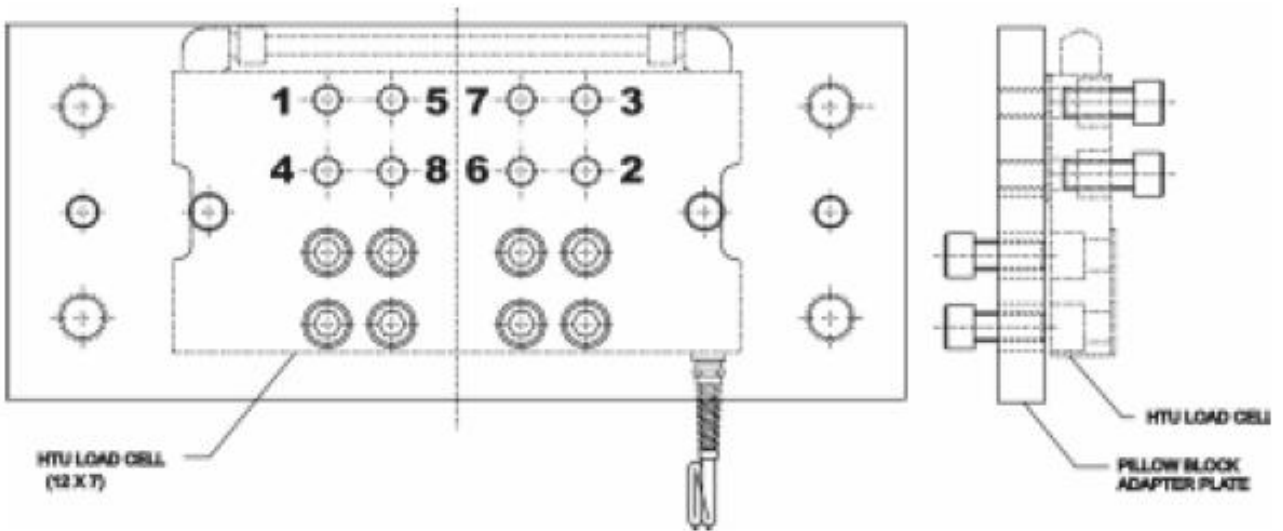

Figure 2-3. HTU to Pillow Block Plate Assembly

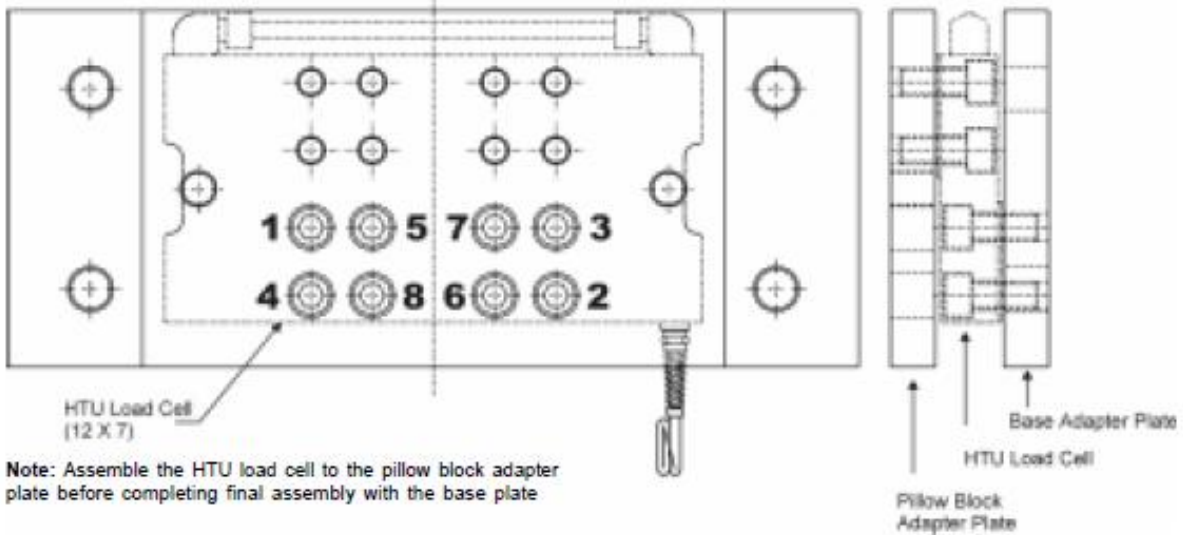

Figure 2-4. HTU to Base Plate Assembly

2.2.3 Attaching the HTU Unit to the Frame/Base

When a base adapter plate is not in use, the HTU mounts directly to the machine frame or base (Figure 2-5). If a base adapter plate is used the size of the plate determines the mounting sequence.

Attaching the HTU to the Frame: Drill and tap holes (5/8-11) in the frame/base according to the pattern shown in Figure 2-4. These holes must be directly in line with the counterbored holes on the HTU transducer (also see Figure 2-1 and 2-1a outline dimensions). Following steps 3 through 6 from the preceding paragraph, bolt the HTU transducer to the frame.

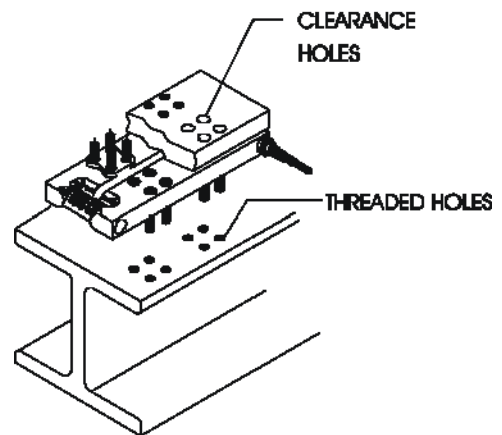

Figure 2-5. HTU to Frame Assembly.

Attaching a base adapter plate that is the same size as the pillow block adapter plate (Figure 2-6): When the base plate is the same size as the pillow block plate, it must be attached to the frame before the HTU transducer. Drill an identical four hole pattern in the base adapter plate and the frame. Bolt the base adapter plate to the frame using 5/8-11x1.5" zinc plated bolts. Torque bolts to one thousand (1000) in/lb.

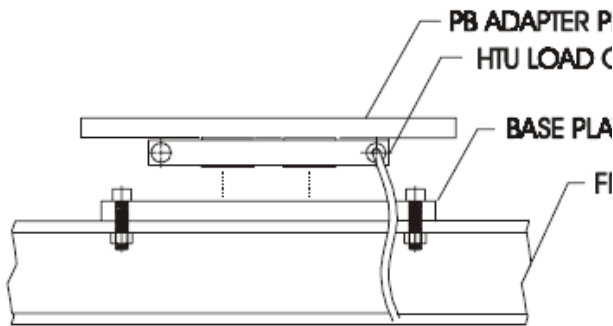

Figure 2-6. Small Base Plate

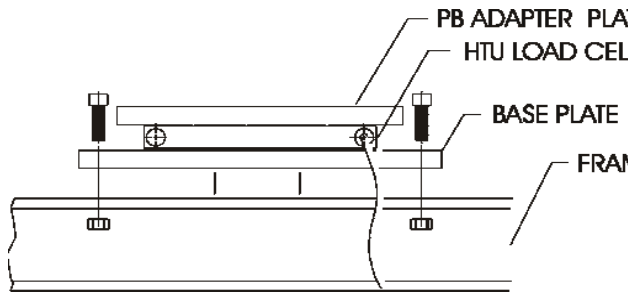

Figure 2-7. Larger Base Plate

Following steps 3 through 6 from the preceding page, bolt the HTU transducer to the base adapter plate.

Installing unit with base plate larger than the pillow block mounting plate (Figure 2-7):

1. Pre-assemble the HTU and both plates as defined in paragraphs 2.2.1 and 2.2.2.
2. Locate the base plate on the frame/base in the desired position.
3. Drill an identical four hole pattern in the base adapter plate and the frame.
4. Bolt the base adapter plate to the frame using 5/8-11x1.5" zinc plated bolts. Torque bolts to 1000 in/lb.

NOTE: If alignment is necessary, mill slotted holes in the base adapter plate to allow final adjustments.

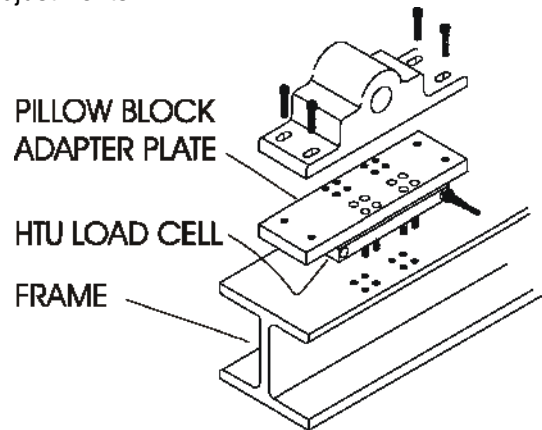

Figure 2-8. Pillow Block Adapter Plate Installation

NOTE: When bolting the pillow block to the pillow block adapter plate, be sure that bolts do not impact, contact, or impede the HTU transducer in any way.

2.2.4 Up-Side-Down Mounting Arrangements

HTU transducers function with the same precision when mounted up-side-down as conventional mounting. BLH, however, recommends installing safety stop bolts for inverse mounting configurations. Use the diagram below as a guide for location and arrangement of safety stop bolts.

2.2.5 Installing the Pillow Block

The final step in mechanical installation is attaching the roll pillow block (Figure 2-8). Center the pillow block, using the length and width center of the HTU cell, upon the pillow block adapter plate. Exercising care (the HTU is now a factor) drill a four hole pattern in the pillow block adapter plate that matches the through holes in the pillow block. Bolt the pillow block to the pillow block adapter plate using appropriate size bolts. Torque bolts to tightness mandated for pillow block mounting (if not known, consult pillow block manufacturer).

2.3 ELECTRICAL CONNECTIONS

Versatile HTU transducers can be connected in a variety of configurations. Optimal usage occurs when both channels (horizontal and vertical) are

connected simultaneously to a custom BLH DXt-40 'Expert' Series Transmitter. Software algorithms in the DXt-40 measure forces in both directions and calculate the precise tension component regardless of wrap angles. When measuring only a single force component (horizontal or vertical), use any BLH transducer indicator. Wiring for all web tension force contingencies will be discussed in the following paragraphs.

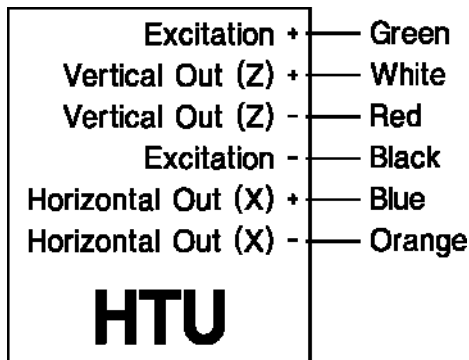

Figure 2-9. HTU Transducer Wiring Color Code

2.3.1 Typical Wiring Designations

The six HTU outputs are depicted in Figure 2-9. Inputting 10 VDC excitation results in two signal outputs, horizontal (X) and vertical (Y). Signal output polarity is always positive. In situations where web tension forces subtract (roll uplift or inverse horizontal applications) from gravitational or anticipated weight force (Figure 2-10), signal polarity (plus and minus) leads MUST BE reversed as shown in Figures 2-?.

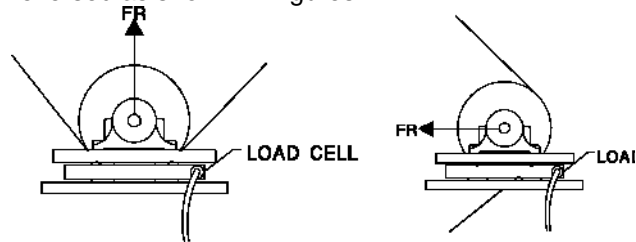

Figure 2-10. Inverted Force Configurations

2.3.2 Dual Channel DXt-40 Wiring

Connecting both X and Z outputs to a custom BLH DXt-40 provides optimal web tension measurement for rolls with asymmetrical or dynamically changing wrap angles. Figure 2-11 (next page) depicts dual channel wiring for one or two HTU transducers. In applications where two HTU transducers support a single roller (one at each roll end) both channels of both transducers must be connected

2.3.3 Single Channel Vertical Wiring

Conventional LCp and DXt instruments accept only the horizontal or vertical force input from an HTU transducer. For applications where entry and exit wrap angles are symmetrical and web tension force is applied vertically to the transducer, connect the (Z) output leads as shown in Figure 2-12. Leave the X output leads disconnected.

2.3.4 Single Channel Horizontal Wiring

For applications where entry and exit wrap angles are symmetrical and web tension force is applied horizontally to the transducer, connect the (X) output leads as shown in Figure 2-13. Leave the Z output leads disconnected.

2.3.5 Shunt Resistor Installation

BLH instruments require unipolar input signals. In applications where web tension force is inversely proportional to gravitational force, roll deadweight should be 'tared out' (electronically negated) by adding a balance (shunt) resistor as shown in Figure 2-14. Use Table 2-1 procedures to calculate the correct resistor value.

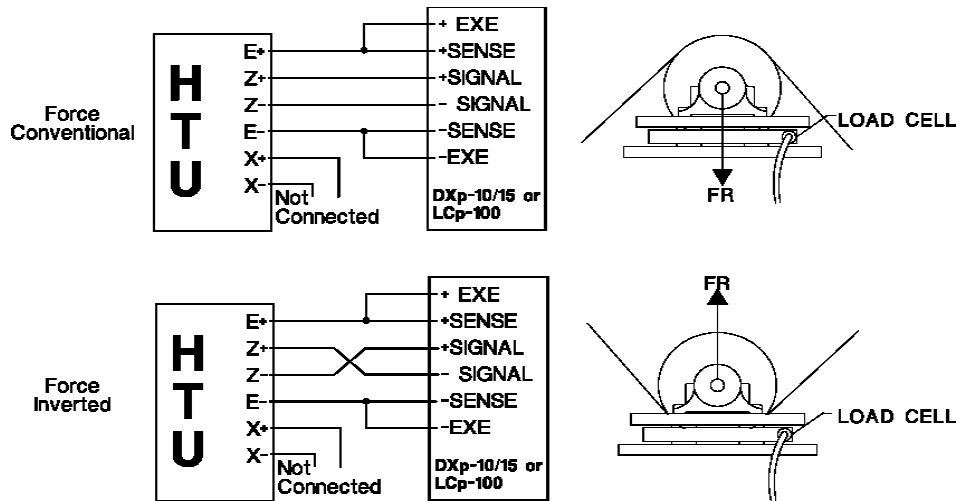

Figure 2-11. DXt-40/HTU Wiring Arrangements

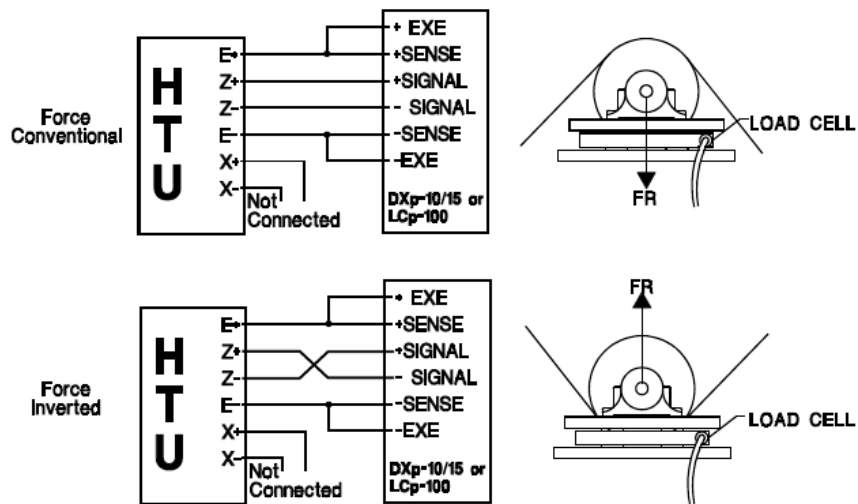

Figure 2-12. Vertical Force Detection Wiring Configurations

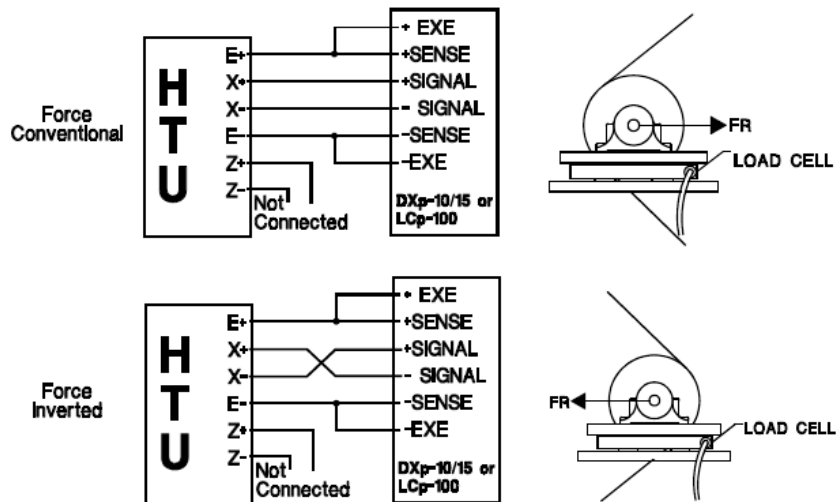

Figure 2-12. Vertical Force Detection Wiring Configurations

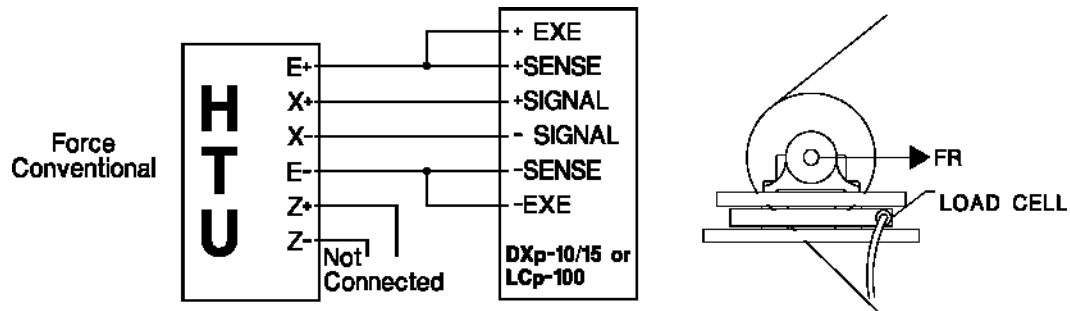

Figure 2-13. Horizontal Force Detection Wiring Configurations

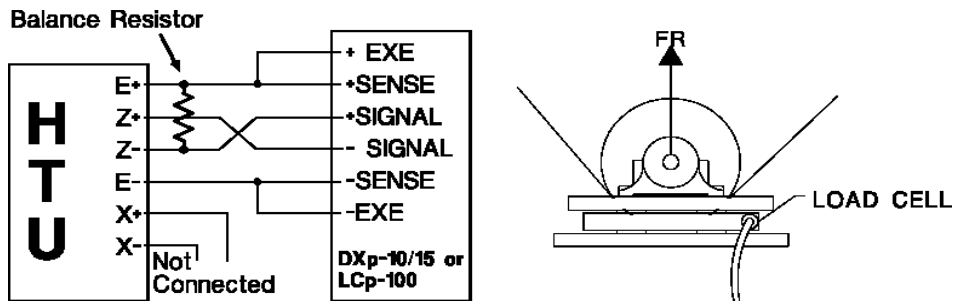

Figure 2-14. Balance Resistor Connection.

PROCEDURE TO CALCULATE EXTERNAL BALANCE (SHUNT) RESISTOR TO CANCEL NEGATIVE PRE-LOAD ON WEB TENSION UNITS (For use with DXt-10/15 and LCp-100 units)

It is not unusual to get a negative millivolt signal from a load cell when it is being used on a web tension system. Sometimes this negative millivolt level is too extreme to allow you to establish a ZERO on the indicating unit.

Use the following procedure to calculate the value of a shunt resistor to place in the DXt/LCp at the termination of the load cell. This resistor must be a high precision wire wound or metal film resistor; carbon resistors are not stable enough to use for this application. This shunt resistor will TARE out the negative preload to a point where the DXt-10/15 can establish ZERO.

Remove the +SIG (wht) and -SIG (red) wires on load cell #1 at the DXt-10 unit. Measure and record the millivolt output from the load cell.

Power off the DXt/LCp unit. Measure and record the bridge resistance across the +SIG (wht) and -SIG (red) wires.

Divide the millivolt value recorded above by the excitation, usually 10vdc, to get a mV/V value. (E.g., -8.1mV=0.81mV/V)

Plug the resistance value and the mV/V value in the following formula:

$$\frac{\text{Load Cell Output Resistance}}{\text{mV/V Value} \cdot 4} = R \text{ shunt (in kohms)}$$

Reconnect the load cell SIG wires, adding the resistor calculated above across the +EXC (grn) and the +SIG (wht) terminals. Repeat this for the second HTU load cell if it also has a negative output value.

Table 2-1. Shunt Resistor Calculations

3 Operation

3.1 THEORY OF OPERATION

The HTU Load Cell symmetrical, universal design measures the resultant force F_R and angle θ of any web tension system with a simple horizontal or vertical installation (Figure 3-1). Cell orientation or the selection of a horizontal or vertical load cell is not required.

Force sensing elements located on each end of the cell measure the components of F_R applied along the Z (F_Z) and X (F_X) axes. Resultant output signals determine the magnitude and direction (1) of the overall force (F_R) applied by the web. A full Wheatstone bridge is mounted internally in each tubular cross section to provide independent sensing for each axis as well as protection from hostile environments.

HTU cells are typically installed beneath the pillow blocks using top and bottom adapter plates. These plates mount on integral loading surfaces designed to produce shear forces in the sensing element. Loading surfaces are located on either side of the longitudinal center slot. They include drilled and centerboard holes to maintain a low profile assembly.

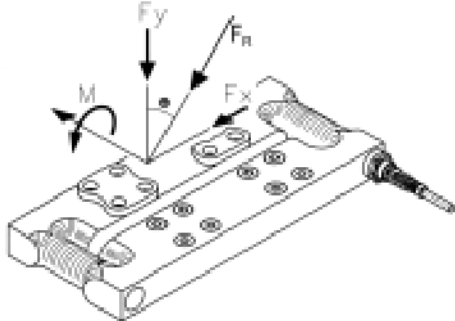

Figure 3-1. Dynamic Tension Measurement

3.2 TEMPERATURE CONSIDERATIONS

HTU Load Cells perform superbly when operated within their compensated temperature range of 0 to +250 degrees Fahrenheit. Such a wide temperature range makes the HTU a perfect selection for hot roll or heat treated applications.

Should ambient temperature exceed the compensated temperature range, special precautions must be taken to ensure that actual module temperature is held within specified

limits. These precautions are necessary whether or not the module is being operated.

3.3 FORCE DISPLACEMENT

With non-symmetrical or varying wrap angles, make certain that force is distributed evenly across the HTU transducer(s). Force exerted on either end of the transducer must not exceed 50% rated capacity. Use the formula shown in Figure 3-2 to calculate the dynamic force at both transducer ends.

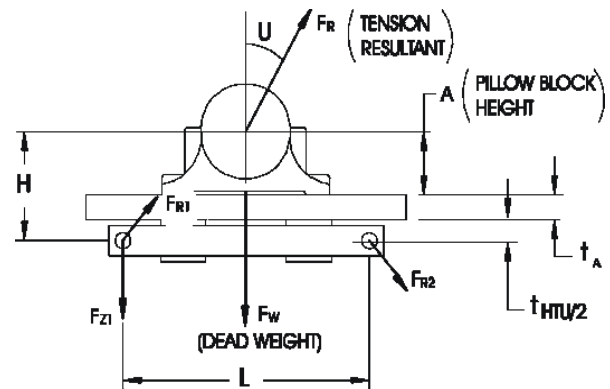

$$H = A + t_A + 0.5t_{HTU}$$

$$F_{R1} = \left[\left(\frac{F_W}{2} - \frac{F_R}{2} \cos \theta - F_R \sin \theta \cdot \frac{H}{L} \right)^2 + \left(\frac{F_R \sin \theta}{2} \right)^2 \right]^{1/2}$$

$$F_{R2} = \left[\left(\frac{F_W}{2} - \frac{F_R}{2} \cos \theta + F_R \sin \theta \cdot \frac{H}{L} \right)^2 + \left(\frac{F_R \sin \theta}{2} \right)^2 \right]^{1/2}$$

Where:
 $L = 10.75$ inches
 $t_{HTU} = 1.4$ inches

If desired, consult BLH application engineers for assistance in choosing the correct capacity HTU (prior to installation).

CAUTION

A static (roll weight) overload in excess of the specified overload rating may permanently affect the accuracy and performance of the module. Peak vibratory loadings should be limited to 100% of rated capacity to preclude premature fatigue failure of the module. Shock loads should be avoided or otherwise attenuated by means of resilient pads or mounts.

4 Maintenance

4.1 CALIBRATION

HTU Load Cells are carefully checked and calibrated at BLH before shipment. The accuracy of BLH instruments and standards used for calibration are traceable to the National Institute of Standards Technology (NIST). A data and calibration sheet is furnished with each unit supplied by BLH. The data included on this sheet can be used as a reference where independent calibration checks are performed.

Calibration can be accurately checked by applying the rated load to the HTU cell and then comparing the output with the original data on the calibration certificate. Calibration should be checked whenever the cell is thought to have been overloaded beyond its safe overload rating (200%). Note that performance cannot be changed through external adjustments and any unit displaying calibration error should be returned to BLH for service.

System calibration instructions are included in the digital indicator/transmitter operator's manual.

4.2 TROUBLESHOOTING

When it is necessary to determine if the HTU circuit is operative, the roller/pillow block does not have to be lifted off the unit in question. Simply read across the signal output leads (red & white or blue & orange depending upon which direction is connected) with a digital voltmeter with power applied to the module. The readings should be somewhat similar, normally in the 5-30 mV range. Any radical departure from these figures is usually indicative of a failure.

To determine the cause of incorrect operation of the measuring system, perform the following inspections:

- a. Check instrument power and fuses.
- b. Check that connections to the instrument are correct and tight.
- c. Check instrument performance independently (typically use BLH Model 325/625 Calibrator).
- d. Check continuity of interconnecting leads.
- e. Check for proper excitation voltage output.
- f. Check output of each HTU unit (each roller end typical) for comparable output levels.
- g. Insulation resistance checks: HTU Cells must be disconnected for leakage test (measured values should exceed 5000 m-ohms).
 - a. Ground to a lead of the interconnecting cable.
 - b. Module case to a lead of the cable.
 - c. Module case to the shield of the cable.
- h. Input/Output resistance check. Disconnect the cable leads from the instrument. Measure the resistance between the input leads and between the output leads. Resistance should be as specified. **OHMMETER USED SHOULD NOT APPLY MORE THAN 20 VOLTS TO THE BEAM BRIDGE.**

Resistance readings other than those listed in the specifications indicate a failure within the unit. **DO NOT** attempt to repair; faulty units require factory service. Contact a local sales office or BLH directly for **RETURN AUTHORIZATION**. Upon examination of the unit at the factory, a full report on the condition with a quotation on repair cost and delivery will be submitted to the customer.



3 Edgewater Drive
Norwood, MA 02062 USA
Phone (781) 298-2200
Fax (781) 762-3988

www.vishaypg.com