

2734A

DIRECT VOLTAGE REFERENCE BANK

OPERATION AND MAINTENANCE MANUAL

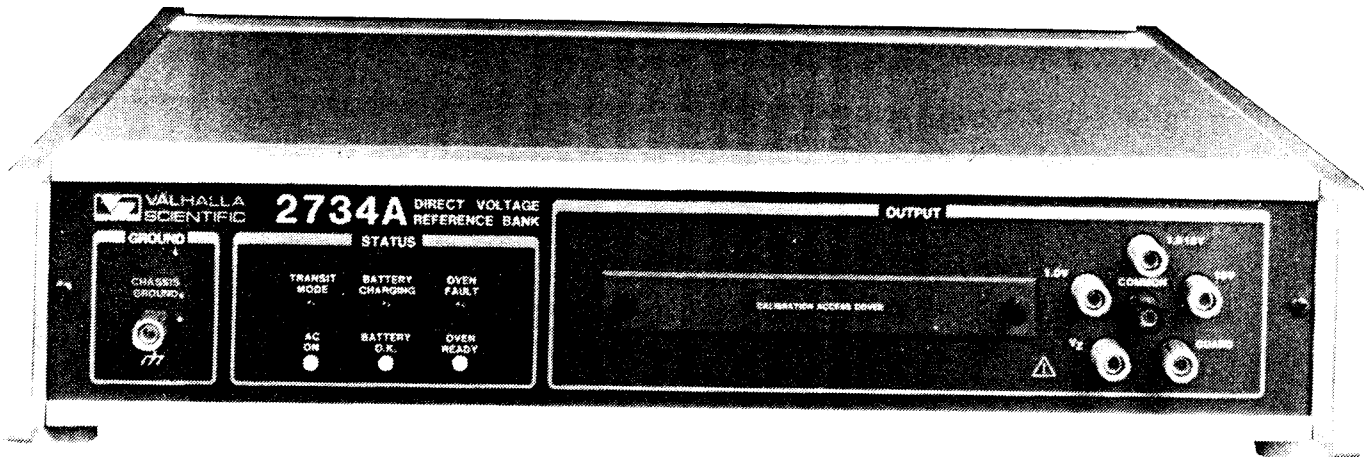

VALHALLA
SCIENTIFIC

9955 Mesa Rim Rd.
San Diego, Ca 92121
Phone (619)457-5576
Telex 181750

REVISED 1/87

CERTIFICATION

Valhalla Scientific, Inc. certifies that this instrument was thoroughly tested and inspected and found to meet its published specifications when it was shipped from the factory. Valhalla Scientific, Inc. further certifies that its calibration measurements are traceable to the National Bureau of Standards to the extent allowed by NBS's calibration facility.

WARRANTY

The warranty period for this instrument is stated on your invoice and packing list. Please refer to these to determine appropriate warranty dates. We will repair or replace the instrument during the warranty period provided it is returned to Valhalla Scientific, Inc. freight prepaid. No other warranty is expressed or implied. We are not liable for consequential damages. Permission and a return authorization number must be obtained directly from the factory for warranty repair returns. No liability will be accepted if returned without such permission.

TABLE OF CONTENTS

SECTION NUMBER	PAGE
SECTION I - UNPACKING AND INSTALLATION	1-1
SECTION II - SPECIFICATIONS	2-1
SECTION III - AVAILABLE OPTIONS	3-1
SECTION IV - FRONT PANEL CONTROLS AND CONNECTIONS	4-1
SECTION V - REAR PANEL CONTROLS AND CONNECTORS	5-1
SECTION VI - MANUAL OPERATION	6-1
SECTION VII - REMOTE OPERATION	7-1
SECTION VII - CALIBRATION	8-1
SECTION IX - MAINTENANCE AND TROUBLESHOOTING	9-1
SECTION X - THEORY OF OPERATION	10-1
SECTION XI - PERFORMANCE VERIFICATION	11-1
SECTION XII - USEFUL HINTS	12-1
SECTION XIII - MANUAL CHANGE INFORMATION	13-1
SECTION XIV - SCHEMATIC AND ASSEMBLY DIAGRAMS	14-1
SECTION XV - PARTS LISTS	15-1

SECTION I - UNPACKING AND INSTALLATION

1.1 Unpacking

If the shipping carton is damaged, request that the carriers' agent be present when the 2734A is unpacked. If the 2734A appears damaged when unpacked, then notify the carriers' agent who should authorize repairs before the 2734A is returned to Valhalla Scientific or Service Center. Even if the 2734A appears undamaged, it may have suffered internal damage in transit that may not be evident until the 2734A is operated or tested to verify performance. If the 2734A fails to meet the performance specifications in Section II, then notify the carriers' agent and Valhalla Scientific or Service Center. Retain the shipping carton for the carriers inspection. **DO NOT RETURN EQUIPMENT TO VALHALLA SCIENTIFIC OR ANY OF ITS SERVICE CENTERS PRIOR TO OBTAINING AUTHORIZATION TO DO SO.**

1.2 Initial Adjustments

The only adjustments required prior to operation of the 2734A are the correct selection of the local power source voltage and to verify that the correct fuse for this voltage is fitted. The supply voltages and fuses are listed below:

105 to 128VAC 50/60Hz	1 Amp Slo Blo Fuse
210 to 256VAC 50/60Hz	0.5 Amp Slo Blo Fuse

The user should note that both fuses are contained within the power socket on the rear panel, and are automatically selected when the power line voltage selection is made. Either 20mm. or 1.25" fuse sizes may be used.

THE 2734A IS SHIPPED IN "TRANSIT MODE", POWERED BY INTERNAL BATTERIES. IT IS RECOMMENDED THAT THE UNIT HAVE POWER APPLIED AS SOON AS POSSIBLE AFTER UNPACKING IN ORDER TO MAINTAIN THE TRACEABILITY OF THE SPECIFICATION.

ENSURE THAT THE CORRECT SELECTION IS MADE PRIOR TO APPLYING POWER TO THE 2734A.

1.3 Instructions for Bench Use

The 2734A is delivered for operation in bench use and special instructions for use in this manner are not required. However, before connecting the 2734A to the AC power source, the user should verify that the power cord is equipped with a three-terminal connector (see the Safety Precautions in 1.5).

1.4 Instructions for Rack Mounting

Optional rack mounting brackets are available for mounting the 2734A in a standard 19" equipment rack. These are listed in Section III of this manual. The size and weight of the 2734A dictate that the unit should be supported on both sides along its entire length (by the use of "trays" or "slides"). If it is to be transported while mounted in a rack then it **MUST BE SUPPORTED SO AS TO PREVENT UPWARDS AND DOWNWARDS MOVEMENT.**

The user should note that the specifications of the 2734A become degraded at high temperatures. It is recommended that sufficient room be allowed for airflow around the 2734A. This may be achieved by placing at least 1.75" high blank panels above and below the 2734A in the rack.

If the unit is placed beneath the 2734A has an exceptionally hot exterior top surface, and it is not possible to alter its location, the user is recommended to fit an aluminum "reflector" plate between this unit and the 2734A.

Under no circumstances should the ambient air temperature surrounding the 2718A be allowed to exceed 50C while in operation or 70C while not in operation.

1.5 Safety Precautions

The power connector should be a three-contact device meeting the safety requirements of the area in which the 2734A is to be used, and should only be mated with a three-contact connector where the third contact provides ground connection. If power is provided through an extension cable then the ground connection must be continuous throughout this cable to the 2734A.

FAILURE TO PROVIDE A CONTINUOUS GROUND CONNECTION TO THE 2734A MAY RENDER THE UNIT UNSAFE FOR USE.

SECTION II - SPECIFICATIONS

2.1 General

The specifications of the 2734A Direct Voltage Reference Bank are listed in the following paragraphs.

2.2 Stability

The stability figures given below are valid for ambient temperatures between 18 and 28C and assume continuous application of power.

OUTPUT	30 days	90 days	180 days	1 year
1.0V	1.0ppm	2.0ppm	3.0ppm	5.0ppm
1.018V	1.0ppm	2.0ppm	3.0ppm	5.0ppm
V _Z	0.4ppm	0.8ppm	1.6ppm	3.0ppm
10V	0.5ppm	1.3ppm	2.5ppm	4.0ppm

Each 2734A is shipped "hot" (in transit mode) from Valhalla Scientific in San Diego, CA, USA, the initial adjustments made by Valhalla Scientific achieves a worst case traceable error against the US national volt of 1.5ppm. This figure may be used with the specifications above as a traceable uncertainty if the 2734A has AC power applied within 48 hours (144 hours if shipped in option TC34) of leaving Valhalla Scientific Inc and following 2 hours stabilization. Each 2734A is shipped with the actual measured values of each output quoted on a certificate with 0.1ppm resolution.

2.3 Settability

Each of the 2734A outputs may be adjusted over the range and with the resolution shown in the table below :

OUTPUT	ADJUSTMENT RANGE	RESOLUTION
1.0V	10ppm total	0.02ppm
1.018V	10ppm total	0.02ppm
V _Z (4 refs)	70ppm total	0.14ppm
V _Z (1 ref)	280ppm total	0.56ppm
10V	5ppm total	0.01ppm

2.4 Temperature Coefficients

The temperature coefficients listed below are applicable within the 0 to 18C and 28 to 40C temperature ranges following 15 minutes of stabilization at the new ambient conditions.

OUTPUT	COEFFICIENT
1.0V	0.1ppm/C
1.018V	0.1ppm/C
V _Z	0.02ppm/C
10V	0.05ppm/C

2.5 Temperature Shock

Ambient temperature changes of greater than 10C per minute may cause a non-accumulative change in output voltage of no greater than 0.01ppm/C change.

2.6 Output Drive and Resistance

The output resistance of each output at the respective terminal is as listed in the table below :

OUTPUT	MAX DRIVE	RESISTANCE
1.0V	---	857.14 ohm +/- 0.005%
1.018V	---	869.95 ohm +/- 0.005%
V _Z	3mA	0.05 ohm maximum
10V	12mA	0.005 ohm maximum

Any (or all) of the outputs may be shorted indefinitely, are protected against the external application of transients up to 1200V peak, and may continuously source or sink up to 100mA of current without permanent damage.

2.7 Supply Regulation

The maximum change in output voltage caused by a change in supply voltage from the minimum to the maximum value/frequency specified is less than 0.05ppm following a 10 second delay. The maximum change in output voltage caused by a change in supply source is less than 0.05ppm following a 10 second delay.

If a complete loss of power occurs then a non-accumulative change in output voltage of less than 0.1ppm may occur following stabilization after re-application of power.

2.8 Output Noise

OUTPUT	0.01 to 10Hz BANDWIDTH	10Hz to 20KHz BANDWIDTH ¹
1.0V	0.1uV peak maximum	3uV RMS maximum
1.018V	0.1uV peak maximum	3uV RMS maximum
V _Z	1uV peak maximum	10uV RMS maximum
10V	1uV peak maximum	10uV RMS maximum

1 Add 2uV RMS maximum if operating from AC power source

2.9 Miscellaneous

Settling time to within 0.1ppm of final value :

Transit to normal mode	:	< 10 minutes
Fully drained batteries to operational	:	< 1 hour
Change in supply source	:	< 10 seconds

Internal Batteries :

Type	:	Sealed Lead-Acid
Charging time	:	12 hours typical (36 hours maximum)
Replacement Interval	:	5 years recommended
Normal mode life	:	At 0C : 15 hours minimum At 20C : 24 hours minimum At 40C : 40 hours minimum
Transit mode life	:	At 0C : 30 hours minimum At 20C : 48 hours minimum At 40C : 100 hours minimum

External DC Supply :

Voltage range	:	+24 to +40VDC
Current drain	:	0.2A typical at 20C (0.8A maximum)
Protection	:	Internally protected against reverse connection and fuse protected (1 Amp) against over voltage.

AC Line Supply :

Voltage/Frequency	:	105 to 130V or 210 to 260VAC at 45 to 440Hz.
Power requirements	:	60VA maximum while charging, 20VA maximum in normal operation.

Safety : Designed to comply with IEC-348 and UL1244

Maximum voltages :	Guard terminal to Common terminal	:	50V peak maximum
	Guard to Chassis Ground	:	100V peak maximum

2.10 Physical

Size : 89mm H x 432mm W x 432mm D (3.5" x 17" x 17")

Weight : 16Kg (35 Lbs) Net
19Kg (42 Lbs) Shipping (without TC34)
29Kg (64 Lbs) Shipping (with TC34)

2.11 Environmental

Temperature Range : Operating : 0 to 40C
Storage : -20 to + 60C

Humidity : 0 to 95% RH at temperatures below 35C
0 to 70% RH at temperatures between 35 and 40C

Altitude -1000 to 10,000 ft.

Vibration Per MIL-T-28800C, Type III, Class 5, Style E

2.12 Recommended Calibration Interval

The calibration interval for the 2734A is dependent on the accuracy the user wishes to maintain. The user should consult the accuracy tables in 2.2 to determine the number of days between calibrations to obtain the required accuracy.

SECTION III - AVAILABLE OPTIONS

3.1 General

This section describes several options available from Valhalla Scientific to increase the utility of the 2734A.

3.2 Option BBL

Option BBL is a dual shielded cable equipped with banana plugs. It is 48 inches long with dual banana plugs of the highest quality and low leakage. This cable is recommended whenever accuracies of greater than 1uV are desired.

3.3 Option RSK-3

Option RSK-3 is a heavy duty rack slide kit which allows simple mounting and removal of a 2734A in an equipment rack. Option RX-3 rack ears are also recommended. It is recommended that option RSK-3 be factory installed.

3.4 Option RX-3

Option RX-3 provides all parts required for mounting the 2734A in a 19 inch equipment rack.

3.5 Option SL-48

Option SL-48 is a 48 inch long shielded cable terminated at each end by high quality gold plated copper spade lugs. The use of this option is recommended whenever accuracies of greater than 0.5uV are desired.

3.6 Option SP-2

This option provides a selection of the most likely parts to fail during the first two years of operation.

3.7 Option TC-34

This option provides a rugged carrying case and rechargeable battery supply for the 2734A. The use of this option is strongly recommended if the 2734A is to be used for repeated transportation or whenever the utmost transfer accuracy is desired.

SECTION IV - FRONT PANEL CONTROLS AND CONNECTORS

4.1 General

This section outlines the use of each of the front panel controls and connectors, the user is advised to read Section VI to obtain full descriptions of the method to operate the 2734A.

The paragraph numbers used in this section correspond to the reference numbers used in figure 4-1.

4.1.1 "CHASSIS GROUND" Terminal

This terminal is connected directly to the chassis of the 2734A and should be grounded whenever the 2734A is operated from AC line and the line cord does not contain a ground connection. It is also recommended that this terminal be grounded whenever the 2734A is operating from DC supply (internal or external) and no AC line cord is present.

4.1.2 "TRANSIT MODE" LED

This LED is illuminated whenever the 2734A is in "Transit Mode" (see Sections V and VI for details). This LED being illuminated indicates that the 2734A is not ready for use.

4.1.3 "BATTERY CHARGING" LED

This LED is illuminated whenever the internal batteries in the 2734A are being charged (from the AC supply). This LED being illuminated indicates that the internal batteries do not have sufficient charge to maintain the battery life specifications in paragraph 2.9.

4.1.4 "OVEN FAULT" LED

This LED is illuminated whenever the internal oven temperature exceeds the regulation temperature by more than 5C. This LED being illuminated indicates that the 2734A has not yet settled from high storage temperatures or, if the condition prevails, the internal temperature regulation circuitry is faulty. Whichever the cause the 2734A is not ready for use if this LED is illuminated. This LED is always extinguished whenever the 2734A is in the "Transit Mode".

4.1.5 "AC ON" LED

This LED is illuminated whenever an AC power source is present and the AC power switch (on the rear panel) is in the ON position (see paragraph 5.1.1).

4.1.6 "BATTERY O.K." LED

This LED is illuminated whenever the internal batteries or external DC supply exceeds the minimum required for correct operation of the 2734A. This LED being extinguished indicates that the 2734A is not ready for use and that the LED indications may be invalid.

4.1.7 "OVEN READY" LED

This LED is illuminated whenever the internal oven temperature is within 0.5C of its final value. This LED being extinguished indicates that the 2734A is not ready for use.

4.1.8 "CALIBRATION ACCESS COVER"

This removable cover gives access to the calibration adjustments. See section VIII for details.

4.1.9 "1.0V", "1.018V", "V_Z", "10V", "COMMON" and "GUARD" Terminals

These terminals provide the voltage outputs from the 2734A and the means to guard the internal circuitry within the 2734A from common mode voltages.

SECTION V - REAR PANEL CONTROLS AND CONNECTORS

5.1 General

The functions of the rear panel controls and connectors are described in the following paragraphs. The paragraph numbers correspond to the reference numbers of Figure 5-1.

5.1.1 "INSTRUMENT POWER" Connector

This connector contains the AC power connector, AC power voltage selection switch, AC power ON/OFF switch and fuses. The AC power switch is in the ON position if the "1" is depressed, and is in the OFF position if the "0" is depressed. The AC line voltage selection is 105 to 130V if "110-120V" is lowermost, and is 210 to 260V if "220-240V" is lowermost. The selection may only be made if the power cord is not inserted into the connector, this is also the case if the fuses are to be changed or inspected. See figure 5-2 for details on changing the fuses or line voltage selection.

5.1.2 "OVEN MODE" Switch

This switch selects either "Transit Mode" or "Operate Mode" of operation. Transit mode reduces the internal power consumption of the 2734A to extend the battery life of the unit while maintaining power to, and the temperature of, the internal references. The "OPERATE" mode must be selected whenever it is desired to use the 2734A.

5.1.3 "EXTERNAL BATTERY" Terminals and "FUSE"

The terminals provide the means by which an external DC power source may be provided to the 2734A. The fuse provides protection for the internal circuitry against excessive voltages on these terminals.

SECTION VI - MANUAL OPERATION

6.1 General

This section provides information regarding the normal use of the 2734A and the transportation methods recommended for use of the 2734A in transfer measurements between laboratories.

6.2 Power Connections

The 2734A has internal batteries to maintain all circuitry within the unit in the absence of sufficient external AC or DC power, these batteries are automatically charged (if they require it) from the AC power input if it is connected and turned ON. The switch over from one power source to another is automatic and virtually transient free.

Inspection of the specifications (see Section II) shows that the accuracy 2734A is virtually unaffected by the power source, thus the user may select the most convenient power source for the application.

6.3 When is the 2734A Ready for Use?

The 2734A is ready for use whenever the following conditions exist :

i) The BATTERY O.K. LED is illuminated

AND

ii) The OVEN READY LED is illuminated

AND

iii) The OVEN FAULT LED is extinguished

AND

iv) The TRANSIT MODE LED is extinguished

AND

v) The CALIBRATION ACCESS COVER is in place

6.4 Using the GUARD Terminal

The GUARD terminal on the front panel of the 2734A is internally connected to a guard "box" completely surrounding the reference and output amplifier circuitry of the 2734A. It should always be connected to a low impedance node, particularly if the 2734A is being operated in excessively electrically noisy environments. In general connection to the COMMON terminal of the 2734A will be sufficient, however it may be necessary to connect this terminal to chassis ground. NEVER LEAVE THIS TERMINAL DISCONNECTED WHEN USING THE 2734A.

6.5 Making Connections to the 2734A

The terminals on the 2734A are made from high quality gold plated tellurium copper, thus thermal emfs are reduced to the least possible. Thermal emfs can however be produced in the connections to the terminals if the wires used are not made from pure copper and/or act as heat conductors to or from the terminals. As with any piece of electronic equipment, the internal temperature of the 2734A is higher than that of the surrounding air, particularly if the unit is near to an air-conditioning duct, thus if the connecting wires are good conductors of heat then thermal emfs can be produced at the contact point to the terminals. Thus the following connection wires types are recommended :

- i) Accuracies in excess of 1uV : Good quality "dual" banana type leads may be used.
- ii) Accuracies in excess of 0.5uV : Good quality copper spade lug terminated shielded cable.
- iii) Best possible accuracies : Twisted pair of 24AWG (or smaller) high parity solid copper conductor, Teflon (or similar) coated wire.

The user should note that the type i) cable offers ease of use and relatively low impedance levels (typically 5 to 25 milliohms) and good performance at the V_Z and 10V output levels, type ii) cable offers good general purpose use at all voltage levels and very low impedances (typically 3 to 10 milliohms), while type iii) cable offers the best possible performance at the cost of ease of use and impedance levels (typically 25 to 200 milliohms).

6.6 Transportation of the 2734A

There are a range of methods for transporting the 2734A while maintaining the integrity of the output voltage specifications, the various methods for each type of movement are described below. Using these methods of shipping 2734A's transfer accuracies of better than 0.1ppm can be achieved, if less accuracy and integrity is required then less precautions need be taken.

6.6.1 Short-Range Movements (no temperature extremes, less than 1 hour)

For short movements within a building the internal batteries and thermal lagging provided within the 2734A are provided for protection against loss of integrity during this type of movement, thus no special precautions are necessary other than ensuring that the batteries have sufficient charge for the movement (check that the BATTERY CHARGING LED is extinguished when powered from AC line prior to disconnection and movement). For this type of movement it is not necessary to select TRANSIT mode, thus minimal stabilization time is required when the 2734A reaches its final destination (as soon as the OVEN READY LED is illuminated the 2734A is ready for use, if no major temperature differences are encountered then this will be immediate).

6.6.2 Short or Medium-Range Movements (exposure to ambient changes, less than 12 hours)

For short or medium range movements where the 2734A may be exposed to large ambient changes or adverse weather conditions (i.e. movement from one building to another) or the movement may take over one hour (but definitely less than 18 hours) then the internal battery supply may still be used and TRANSIT mode is unnecessary, however it is recommended that the unit be shielded from the weather conditions and temperature shocks by wrapping it in weather proof material (plastic "bubble pack" material is excellent). Upon reception of the 2734A after the movement the unit should be powered from AC power as soon as possible to recharge the internal batteries, the 2734A will be ready for use as soon as the OVEN READY LED is illuminated (typically within 1 or 2 minutes, immediately if the conditions were not severe).

6.6.3 Long-Range Movements (less than 30 hours)

For long range movements or whenever it is possible that the 2734A may be left without AC power for extended periods of time (but less than 30 hours, e.g. between facilities) then the precautions indicated for medium range movements (6.6.2 above) should be followed with the addition of the selection of TRANSIT MODE prior to shipment. It is also recommended that the 2734A be shipped in a shipping container capable of withstanding typical shipping shocks (it is recommended that the user retain the Valhalla Scientific shipping container for this purpose). If the 2734A is to transported in a car then it is recommended that it is placed in the passenger compartment, rather than in the trunk, and should not be left in the vehicle overnight, to protect the 2734A from the extremely wide range of temperatures and humidities present in the trunks of cars. If the 2734A is not be "personally" transported then it is recommended that the user clearly mark receiving instructions (i.e. instructions to unpack the unit and apply AC power as soon as possible) on the exterior of the shipping container.

NOTE : IF THE TRAVEL MAY BE DELAYED BY PREVAILING WEATHER CONDITIONS (E.G. AIR TRAVEL DELAYS DUE TO SNOW ETC.) THEN THE PROCEDURE IN 6.6.4 IS RECOMMENDED.

6.6.4 Long-Range Movements (less than 6 days)

For very long range movements or whenever the utmost integrity is required then the user should place the 2734A in an option TC-34 carrying case where both the unit and the carrying case have been fully charged (neither unit has a CHARGING LED illuminated when powered from AC power). The option TC-34 offers protection against shipping damage and thermal shock, while powering the 2734A for the entire time (the 2734A should have TRANSIT MODE selected if the transit time is longer than 3 days).

6.6.5 Very Long-Range Movements and/or Very Adverse Conditions

The 2734A has been designed to withstand a very wide range of temperatures with a minimum of user support, however some conditions may adversely affect the integrity of the performance. If very adverse conditions are expected during transportation of the 2734A then the user is recommended to consult the nearest Valhalla Scientific Service Center prior to shipping the 2734A. The user may wish to individually measure each of the four internal references prior to shipment and then compare their measurements upon reception, if any reference movement does occur it is extremely unlikely that all four

references will be affected, thus the integrity of the absolute value of the V_Z output voltage can be maintained since no major elements effect this output other than the references themselves, the other outputs can then be ratiometrically calibrated (see Section VIII) at the receiving end.

- i) Possibility of very low temperatures (e.g. travel in the Polar regions).
The internal circuitry is ovened even when in TRANSIT mode, thus even temperatures as low as -40C will not adversely affect the references and output amplifiers. However, the internal lead-acid batteries will not withstand these temperatures thus they should be removed and some form of external DC power source used to maintain the internal temperature during movement. Lithium or some Nickel-Cadmium batteries have excellent performance at sub-zero temperatures and are recommended. The possibility of extreme temperature shock exists in these conditions, thus the user is strongly recommended to thoroughly thermally insulate the 2734A.
- ii) Possibility of very high temperatures (e.g. travel in the equatorial desert regions).
Experience with semiconductor references has shown that temperatures in excess of 85C may cause shifts in their voltages, also the internal lead-acid batteries may be damaged by such extreme temperatures. Thus the user is strongly recommended to remove the internal batteries and to ensure that the 2734A is maintained away from direct sunlight while being transported in these conditions (in general, the ambient air temperature does not attain these very high temperatures but direct sunlight can cause surfaces to exceed even 100C in these conditions).
- iii) Possibility of extended time periods.
The external DC power input may be connected to any convenient source of power between 24V and 40VDC and the internal circuitry of the 2734A will maintain operation for inputs down to 15VDC under normal conditions, thus the user may construct any power source if the length of the journey is known. If the journey (or storage) of the 2734A becomes extensively extended and the power source becomes ineffective then the 2734A is specified to yield a worst case change in output voltage of 0.1ppm which is adequate for all but the most decerning of measurements.

6.7 Typical Connections and Usages

Connections and typical usages of the 2734A are shown in the various figures at the end of this section. The user should note that when two (or more) 2734A units are connected in series to obtain higher voltages then the units should be powered by their internal battery supplies and the CHASSIS GROUND terminals left open circuit for the best in performance (NOTE - THIS MAY CAUSE THE CHASSIS TO HAVE DANGEROUS POTENTIALS, CARE MUST BE TAKEN).

SECTION VII - REMOTE OPERATION

THIS SECTION IS INTENTIONALLY LEFT BLANK FOR PROPOSED FUTURE DEVELOPEMENT.

SECTION VIII - CALIBRATION

8.1 General

The 2734A is calibrated with the covers on. Access to the adjustment potentiometers and switches is made by removing the calibration access port cover located on the front panel. A calibration certificate sticker may be placed over the access port cover to preserve calibration integrity.

8.2 Removing the Calibration Cover

To remove the calibration access cover, gently pull out the two plungers on the cover about 1/8". Pull evenly on the two plungers to remove the cover. To replace the cover, ensure that plungers are in the withdrawn position. Line the grommets up with the holes in the front panel and gently press the cover into place. Push the two plungers in until they are seated.

8.3 Calibration Following Component Replacement

If a component has been replaced, damaged by misuse, or a long period of time has elapsed since the factory calibration, the calibration potentiometers may not have enough range. The range of the potentiometers may be moved by changing the positions of the shorting plugs on the resistor banks in the reference enclosure. Access to these plugs is made by removing the upper front bezel, the instrument top cover, the reference enclosure top cover and then the upper insulation covering (see figure 8-1).

8.4 General Calibration Philosophy

The calibration of the 2734A can be achieved in one of three differing ways, dependant on user requirements :

- i) For most usages and for routine periodic calibration of the 2734A it is not necessary to actually correct for any deviations in the output voltages of the 2734A, it is only required to exactly "know" and record the actual values. In this case it is not necessary to remove the CALIBRATION ACCESS COVER, it is only necessary to measure the actual output voltages. The procedure for performing this is dependant on personal preference and the equipment available however the method used by Valhalla Scientific Inc. is outlined in paragraph 8.5 below.
- ii) Where it is not necessary to adjust the outputs to exactly the correct, nominal, voltages (similar to i) above) but the integrity of the 2734A absolute voltage is to be checked then measurements of each individual reference "cell" and checking of the averaging of these "cells" will be required. In this case the CALIBRATION ACCESS COVER must be removed, however no adjustments of the potentiometers will be required. The procedure which Valhalla Scientific Inc. uses to perform this is outlined in paragraph 8.6 below.
- iii) When it is required to correct for deviations of the actual output voltages from the nominal or realign the individual reference "cells" then adjustments of the internal potentiometers will be required and the CALIBRATION ACCESS COVER must be removed. The procedure which Valhalla Scientific Inc. uses is outlined in paragraph 8.7 below.

8.4.1 Pre-Calibration Preparation

Very little preparation of the 2734A is required prior to calibration, however the following items should be followed :

- i) The 2734A should have the internal batteries fully charged (CHARGING LED should be extinguished).
- ii) The 2734A should have been stabilized in the calibration environment for at least two hours prior to making measurements.
- iii) Final calibration measurements should be made with all of the covers in place, 30 minutes stabilization should be allowed following replacement of the top cover. If accuracies of better than 0.2ppm are required then measurements must be made with the CALIBRATION ACCESS COVER in place (5 minute stabilization is recommended).

8.5 Measurement of Actual Output Voltages Without Adjustment

This paragraph describes the method by which Valhalla Scientific Inc. measures the actual voltages present on each of the four outputs from the 2734A. The user may use any method which is acceptable for the accuracy level which is required in the actual application, the user may also wish to record the measured values (along with some computed ratios) in the same manner as Valhalla Scientific Inc. does on a form similar to that shown in Table 8-1 (this may aid the user in determining error sources should a discrepancy occur). The measurements may be performed in any order since no adjustments are performed. Throughout these procedures it is assumed that the user is conversant with the normal use of the equipment listed, and that the equipment is in good working order and has been recently calibrated.

8.5.1 Measurement of the 1.018V Output Voltage

- Equipment Used :
- i) Standard Cell with exact value known.
 - ii) Valhalla 2720GS or HSR.

Step 1 Short the nullmeter terminals on the 2720 and short them to the OUTPUT LOW terminal on the 2720 using 24AWG bus wire or similar. Turn on the nullmeter and allow any thermal emfs to subside. Zero the nullmeter.

Step 2 Remove the shorting wires on the nullmeter of the 2720. Select a DIVIDED output voltage from the 2720 of the same value and polarity as the selected standard cell. Turn off the nullmeter. Using 24AWG teflon coated connection wires (or similar) connect the standard cell to the 2720 as follows :

Cell LOW	to	2720 OUTPUT LOW
2720 OUTPUT HI	to	2720 Nullmeter HI
Cell HI	to	2720 Nullmeter LO

Select the AUTO NULL mode of operation on the 2720 with a division ratio of +0.25, select for the deviation to be displayed in PPM. Note the settled value of deviation displayed on the 2720. Turn off the nullmeter and remove the connections to the nullmeter (be careful not to short them).

- Step 3 Repeat Step 2 with the following connections (ensure that the cell voltage value is re-entered on the 2720):
 Cell LOW to 2720 OUTPUT LOW (should be already present)
 2720 OUTPUT HI to 2720 NULLMETER LO
 Cell HI to 2720 NULLMETER HI
 Select the AUTO NULL mode of operation on the 2720 with a division ratio of -0.25 (NOTE POLARITY). Note the settled value of deviation displayed on the 2720. Turn off the nullmeter and remove the connections to the nullmeter (be careful not to short them).
- Step 4 Repeat steps 2 and 3 for each cell in the cell bank (the user may make as many measurements as wished), separately noting each ppm deviation of the 2720.
- Step 5 Calculate the mathematical average of all of the ppm deviations recorded for the steps 2 and 3, i.e. add up all of the deviations and divide the result by the number of measurements taken. THIS DEVIATION IS THE ERROR OF THE 1 VOLT DIVIDED RANGE OF THE 2720 AND MAY BE RECORDED IN THE CALIBRATION RECORD OF THE 2720 IF DESIRED (NEGATIVE RESULT INDICATES THAT THE 2720 OUTPUT IS HIGHER THAN EXPECTED). Note this calculated ppm deviation (be careful to record the polarity of the error. If desired the standard deviation of the data may also be calculated (this gives an indication of the random error in the measurement). THE USER MAY ALSO NOTE THAT INTER-CELL COMPARISONS MAY BE ACHIEVED AT THE SAME TIME, THE AVERAGE OF EACH CELL'S STEP 2 AND 3 DEVIATION MAY BE INTER-COMPARED YIELDING THE ACTUAL PPM DEVIATION FROM CELL TO CELL.
- Step 6 Remove all connections from the 2720 and the standard cell bank.
- Step 7 Select a DIVIDED output from the 2720 of +1.01800000 V then enter the ppm deviation obtained in step 5 (ensure that the same polarity is used). The 2720 output voltage is thus set to EXACTLY 1.01800000 V. The worst case error in the 2720 output is 0.25ppm (typically < 0.1ppm).
- Step 8 Using the same wires as used to connect the standard cells above, connect the 2720 to the 2734A as follows :
 2734A COMMON to 2720 OUTPUT LOW
 2720 OUTPUT HI to 2720 NULLMETER HI
 2734A 1.018V to 2720 NULLMETER LOW
 Select the AUTO NULL mode of operation on the 2720 with a division ratio of +0.25, select for the deviation to be displayed in PPM. Note the settled value of deviation displayed on the 2720. Turn off the nullmeter and remove the connections to the nullmeter (be careful not to short them).

Step 9 Repeat Steps 7 and 8 with the following connections (ensure that the value is re-entered on the 2720):
2734A COMMON to 2720 OUTPUT LOW (should be already present)
2720 OUTPUT HI to 2720 NULLMETER LO
2734A 1.018V to 2720 NULLMETER HI
Select the AUTO NULL mode of operation on the 2720 with a division ratio of -0.25 (NOTE POLARITY). Note the settled value of deviation displayed on the 2720. Turn off the nullmeter and remove all connections.

Step 10 Compute the average of the two deviations recorded in steps 8 and 9. This value is the ppm deviation of the 1.018V output of the 2734A from the nominal value, a negative value indicates that the 2734A actual output voltage is lower than nominal.

Using the above procedure the worst case error is 0.5ppm, however due to averaging of measurements and the procedure used the nominal error (RMS of errors) is less than 0.3ppm worst case and typically less than 0.1ppm (plus the traceability error of the standard cells).

8.5.2 Measurement of the 1.0V Output Voltage

This measurement follows the same procedure as shown for the 1.018V output in paragraph 8.5.1 above, however a voltage of 1.00000000 V is used in steps 7, 8 and 9, and the error is increased (due to the slightly extended range over which the linearity of the 2720 is used) by 0.05ppm worst case. Note that if the 1.018V output was measured immediately preceding this measurement then steps 1 through 6 are unnecessary, the data calculated in step 5 of 8.5.1 being re-used.

8.5.3 Measurement of the 10V Output Voltage

The user should note that this procedure is basically the same as that performed for the 1.0V and 1.018V outputs and is fully explained only for clarity.

Equipment Used : i) Standard Cell with exact value known.
 ii) Valhalla 2720GS or HSR.
 iii) Precision 10:1 divider (10.18V:1.018V and 10V:1V)

NOTE : Throughout this procedure it is assumed that the divider has a relatively high input impedance and thus four terminal connections are not required (for a Fluke 752A with wires <4 feet in length, two terminal connection is adequate).

Step 1 Short the nullmeter terminals on the 2720 and short them to the OUTPUT LOW terminal on the 2720 using 24AWG bus wire or similar. Turn on the nullmeter and allow any thermal emfs to subside. Zero the nullmeter.

Step 2 Remove the shorting wires on the nullmeter of the 2720. Select an output voltage from the 2720 of the ten times the value and the same polarity as the selected standard cell. Turn off the nullmeter. Using teflon coated connection wires of the gauges indicated (or similar) connect the standard cell, divider and the 2720 as follows :

2720 OUTPUT LO	to	Divider Input LO	20AWG wire
2720 OUTPUT HI	to	Divider Input HI	20AWG wire
Cell LOW	to	Divider Output LO	24AWG wire
Divider Output HI	to	2720 Nullmeter HI	24AWG wire
Cell HI	to	2720 Nullmeter LO	24AWG wire

Note that if a Fluke 752A divider is used then some of these connections are made internal to the divider, care must be taken to ensure that the cell is correctly connected to the divider otherwise it may be damaged, care must also be taken to ensure that the nullmeter is of the correct polarity.

Select the AUTO NULL mode of operation on the 2720 with a division ratio of +0.025, select for the deviation to be displayed in PPM. Note the settled value of deviation displayed on the 2720. Turn off the nullmeter and remove the connections to the nullmeter (be careful not to short them).

Step 3 Repeat Step 2 with the following connections (ensure that the initial voltage value is re-entered on the 2720):

2720 OUTPUT LO	to	Divider Input LO	20AWG wire (already present)
2720 OUTPUT HI	to	Divider Input HI	20AWG wire (already present)
Cell LOW	to	Divider Output LO	24AWG wire (already present)
Divider Output HI	to	2720 Nullmeter LO	24AWG wire
Cell HI	to	2720 Nullmeter HI	24AWG wire

Select the AUTO NULL mode of operation on the 2720 with a division ratio of -0.025 (NOTE POLARITY). Note the settled value of deviation displayed on the 2720. Turn off the nullmeter and remove the connections to the nullmeter (be careful not to short them).

Step 4 Repeat steps 2 and 3 for each cell in the cell bank (the user may make as many measurements as wished), separately noting each ppm deviation of the 2720.

Step 5 Calculate the mathematical average of all of the ppm deviations recorded for the steps 2 and 3, i.e. add up all of the deviations and divide the result by the number of measurements taken. THIS DEVIATION IS THE ERROR OF THE 10 VOLT RANGE OF THE 2720 AND MAY BE RECORDED IN THE CALIBRATION RECORD OF THE 2720 IF DESIRED (NEGATIVE RESULT INDICATES THAT THE 2720 OUTPUT IS HIGHER THAN EXPECTED). Note this calculated ppm deviation (be careful to record the polarity of the error. If desired the standard deviation of the data may also be calculated (this gives an indication of the random error in the measurement). THE USER MAY ALSO NOTE THAT INTER-CELL COMPARISONS MAY BE ACHIEVED AT THE SAME TIME, THE AVERAGE OF EACH CELL'S STEP 2 AND 3 DEVIATION MAY BE INTER-COMPARED YIELDING THE ACTUAL PPM DEVIATION FROM CELL TO CELL.

Step 6 Remove all connections from the 2720, divider and the standard cell bank.

Step 7 Select an output from the 2720 of +10.0000000 V then enter the ppm deviation obtained in step 5 (ensure that the same polarity is used). The 2720 output voltage is thus set to EXACTLY 10.0000000 V. The worst case error in the 2720 output is 0.25ppm (typically < 0.1ppm).

Step 8 Connect the 2720 to the 2734A as follows using 24AWG wires :
2734A COMMON to 2720 OUTPUT LOW
2720 OUTPUT HI to 2720 NULLMETER HI
2734A 10V to 2720 NULLMETER LOW
Select the AUTO NULL mode of operation on the 2720 with a division ratio of +0.25, select for the deviation to be displayed in PPM. Note the settled value of deviation displayed on the 2720. Turn off the nullmeter and remove the connections to the nullmeter (be careful not to short them).

Step 9 Repeat Steps 7 and 8 with the following connections (ensure that the value is re-entered on the 2720):
2734A COMMON to 2720 OUTPUT LOW (should be already present)
2720 OUTPUT HI to 2720 NULLMETER LO
2734A 10V to 2720 NULLMETER HI
Select the AUTO NULL mode of operation on the 2720 with a division ratio of -0.25 (NOTE POLARITY). Note the settled value of deviation displayed on the 2720. Turn off the nullmeter and remove all connections.

Step 10 Compute the average of the two deviations recorded in steps 8 and 9. This value is the ppm deviation of the 10V output of the 2734A from the nominal value, a negative value indicates that the 2734A actual output voltage is lower than nominal.

Using the above procedure the worst case error is 0.5ppm, however due to averaging of measurements and the procedure used the nominal error (RMS of errors) is less than 0.3ppm worst case and typically less than 0.1ppm (plus the traceability error of the standard cells and the error of the divider).

8.5.4 Measurement of the V_Z Output Voltage

This measurement follows the same procedure as shown for the 10V output in paragraph 8.5.3 above, however a voltage of 7.0000000 V is used in steps 7, 8 and 9, and the error is increased (due to the slightly extended range over which the linearity of the 2720 is used) by 0.2ppm worst case. Note that if the 10V output was measured immediately preceding this measurement then steps 1 through 6 are unnecessary, the data calculated in step 5 of 8.5.3 being re-used.

8.5.5 Recording and Analyzing Data

As shown in Table 8-1, the deviations of the 1.018V (A), 1.0V (B), 10V (C) and V_Z (D) outputs and the differences between the deviations of the 1.018V and V_Z (E), 1.0V and V_Z (F), and the V_Z and 10V (G) outputs should be recorded.

- i) If data (E), (F) and (G) are similar then the measurement of the V_Z output is suspect and should be repeated.

- ii) If data (E) and (F) are similar, but not similar to data (G) then the measurements of the 10V and V_Z outputs are suspect (possibly the standardization of the 2720 or the divider itself could be suspect) and should be repeated.
- iii) If data (A) and (B) are similar to previous measurements but measurements (C) and/or (D) are not, then all measurements are suspect and should be repeated.
- iv) Any change in data (D) should also reflect in changes of data (A), (B) and (C). If this is not the case then all measurements are suspect and should be repeated.

8.6 Measurement of Actual Output Voltages and Inter-Cell Comparison Without Adjustment.

This paragraph describes the preferred method by which "Inter-Cell" comparison is performed within the 2734A. This comparison is normally followed by the normal measurement of the actual output voltage values of the 2734A, this was described in paragraph 8.5 above, thus is not described in this paragraph.

Equipment Required : Valhalla 2720GS or HSR

- Step 1 Remove the CALIBRATION ACCESS COVER from the 2734A (see paragraph 8.2). Select all functional references to be in use (all switches down). If it has been previously determined that one reference is faulty then it may be deleted (switch up).
- Step 2 Short the nullmeter terminals on the 2720 and short them to the OUTPUT LOW terminal on the 2720 using 24AWG bus wire or similar. Turn on the nullmeter and allow any thermal emfs to subside. Zero the nullmeter then turn it off.
- Step 3 Remove all connections from the 2720 nullmeter. Set the 2720 output voltage to 7.0000000 V and provide the following connections using 24AWG teflon coated wire (or similar) :

2720 OUTPUT LOW	to	2734A COMMON
2720 OUTPUT HI	to	2720 NULLMETER HI
2734A V_Z	to	2720 NULLMETER LOW

 Select AUTO NULL mode on the 2720 with a division ratio of +0.25 and select for the deviation to be displayed in PPM. After settling deselect AUTO NULL.
- Step 4 Turn ON the nullmeter, the deviation display should show approximately zero PPM (within 3ppm is sufficient).
- Step 5 Turn off all but one reference cell in the 2734A (i.e. all switches but one should be up). NEVER DESELECT ALL CELLS OF THE 2734A. After the 2720 nullmeter has settled, note the displayed deviation.
- Step 6 Repeat step 5 for each reference in turn (select the next reference then deselect the previous) until measurements have been made and noted for all four references.

- Step 7** If the difference between the smallest (i.e. most negative) deviation and the largest (i.e. most positive) deviation is greater than 30ppm then realignment of the references is required and the procedure in paragraph 8.7 should be followed.
- Step 8** Repeat step 5 for each possible pair of references (i.e. 1+2, 1+3, 1+4, 2+3, 2+4, 3+4). Check that the measurements obtained are within 0.5ppm of the average of the two individual measurements obtained in step 5. If any measurement fails then repeat each individual measurement and re-check, if this still fails then the 2734A is faulty and should be repaired.
- Step 9** Select all four references and replace the CALIBRATION ACCESS COVER.
- Step 10** Compute and record on a form similar to that shown in table 8-2 the actual measured deviations in steps 5, 6 and 8 (data [A] through [J]), the average of the deviations measured in step 8 (data [K]), and the actual measured deviation for each reference (steps 5 and 6) minus the average deviation from step 8 (data [L] through [O]).
- Step 11** After 5 minutes stabilization, perform the measurements of paragraph 8.5 above.

8.6.1 Analysis of Results

Data [L] through [O] represent the ppm deviation of each individual cell from the average of all four references, thus (given singular major events) it is possible to immediately note changes in the value of a single reference cell and compute its affect on the average. This is seen by one cell having a large change in deviation (ΔD) and the other three having a smaller change in deviation of the opposite polarity (change should be $1/3$ of ΔD approximately), this indicates that the particular cell has changed its value by $4 \cdot \Delta D / 3$ ppm and thus the average will have been altered by $\Delta D / 3$ ppm. This can be checked (if available) against any change in the actual voltage of the V_Z output, any remaining change being caused by shifts in the other three cells.

8.7 Adjustment of Output Voltages and/or Realignment of Reference Cells.

This procedure basically follows the same procedure as shown in 8.5 and 8.6 above, however the user adjusts the errors to be as small as desired. When making adjustments of the potentiometers in the 2734A it is important that they be made in the correct order, as each adjustment has an affect on the others. The outputs which are affected by each adjustment are as follows :

- i) Cell adjustment : Affects all output voltages by 0.25 times adjustment made.
- ii) 1.0V adjustment : Affects 10V output by 0.05 times adjustment made.
- iii) 1.018V adjustment : Affects 10V output by 0.05 times adjustment made.
- iv) 10V adjustment : Has no affect on other output voltages.

8.7.1 Adjustment of Individual Reference Cells

This procedure adjusts each cell to be nominally 7.000V and to be within +/- 5ppm of the average value. Note that all other adjustments and/or measurements must be made following adjusting any of the REF 1, REF 2, REF 3 or REF 4 adjustments.

- Step 1** Follow the procedure in 8.5.3 steps 1 through 6 (i.e. standardize the 2720).
- Step 2** Select an output of 7.0000000 V from the 2720 and connect the 2720 to the 2734A as follows using 24AWG teflon coated wire (or similar) :
- | | | |
|----------------------|----|-------------------|
| 2734A COMMON | to | 2720 OUTPUT LOW |
| 2720 OUTPUT HI | to | 2720 NULLMETER LO |
| 2734A V _Z | to | 2720 NULLMETER HI |
- Turn on the nullmeter on the 2720 and select for the deviation display to be in PPM. For each reference cell in turn being singularly selected (only one switch down) adjust the respective "REF N" potentiometer for a nullmeter indication of < +/- 5ppm. Turn off the nullmeter, remove all connections and reselect all references.

8.7.2 Adjusting the 1.0V Output

Note that the 10V output adjustment and/or measurement may have to be remade following adjusting the 1.0V output.

- Step 1** Follow the procedure in 8.5.1 steps 1 through 6 (i.e. standardize the 2720).
- Step 2** Select an output of 1.0000000 V from the 2720 and connect the 2720 to the 2734A as follows using 24AWG teflon coated wire (or similar) :
- | | | |
|----------------|----|-------------------|
| 2734A COMMON | to | 2720 OUTPUT LOW |
| 2720 OUTPUT HI | to | 2720 NULLMETER LO |
| 2734A 1.0V | to | 2720 NULLMETER HI |
- Turn on the nullmeter on the 2720 and select for the deviation display to be in PPM. Adjust the 1.0V potentiometer for a minimum nullmeter reading (within the limits required by the user). Turn off the nullmeter and remove all connections.

8.7.3 Adjusting the 1.018V Output

Note that the 10V output adjustment and/or measurement may have to be remade following adjusting the 1.018V output.

- Step 1** Follow the procedure in 8.5.1 steps 1 through 6 (i.e. standardize the 2720). This step is unnecessary if the 1.0V adjustment was made immediately prior to making this adjustment.
- Step 2** Select an output of 1.0180000 V from the 2720 and connect the 2720 to the 2734A as follows using 24AWG teflon coated wire (or similar) :
- | | | |
|----------------|----|-------------------|
| 2734A COMMON | to | 2720 OUTPUT LOW |
| 2720 OUTPUT HI | to | 2720 NULLMETER LO |
| 2734A 1.018V | to | 2720 NULLMETER HI |
- Turn on the nullmeter on the 2720 and select for the deviation display to be in PPM. Adjust the 1.018V potentiometer for a minimum nullmeter reading

(within the limits required by the user). Turn off the nullmeter and remove all connections.

8.7.4 Adjusting the 10V Output

- Step 1** Follow the procedure in 8.5.3 steps 1 through 6 (i.e. standardize the 2720). Note that if the reference cell adjustment (8.7.1) was made immediately prior to this adjustment then this step is unnecessary.
- Step 2** Select an output of 10.0000000 V from the 2720 and connect the 2720 to the 2734A as follows using 24AWG teflon coated wire (or similar) :
- | | | |
|----------------|----|-------------------|
| 2734A COMMON | to | 2720 OUTPUT LOW |
| 2720 OUTPUT HI | to | 2720 NULLMETER LO |
| 2734A 10V | to | 2720 NULLMETER HI |
- Turn on the nullmeter on the 2720 and select for the deviation display to be in PPM. Adjust the 10V potentiometer for a minimum nullmeter reading (within the limits required by the user). Turn off the nullmeter and remove all connections.

8.7.5 Post-Adjustment Procedure

After making any adjustment to the 2734A it is recommended that the measurement procedure be followed in full (paragraph 8.5) to check that the adjustments have been correctly made. The user should note that the CALIBRATION ACCESS COVER should be in place during these measurements.

8.8 Internal Link Selection

After some period of time, or following component replacement, it may become necessary to re-center one or more of the adjustment potentiometers. This is achieved by means of binary weighted links behind each adjustment. These links can be accessed by removing the front upper bezel, followed by removing the top cover, followed by removing the top cover of the Reference Enclosure. Each link pattern is immediately behind its respective adjustment potentiometer and is orientated such that the link with the smallest effect is towards the front of the 2734A, each link further back having almost twice the effect of the previous link.

SECTION IX - MAINTENANCE AND TROUBLESHOOTING

9.1 General

The following paragraphs provide the information required to perform the required periodic maintenance and basic guidelines for troubleshooting the 2734A.

9.2 Periodic Maintenance

The 2734A requires little periodic maintenance, that which is required is discussed in the following paragraphs.

9.2.1 Cleaning

It is recommended that the 2734A be operated in a clean environment, however, if the environment is "dusty" then periodic cleaning of the unit will be required.

Loose dirt or dust, which is collected on the exterior surfaces of the 2734A may be removed with a soft cloth or brush. Any remaining dirt may be removed with a soft cloth dampened in a mild soap and water solution. **Do not use abrasive cleaners.**

The front panel may be cleaned with a soft cloth and a "Windex" type cleaner. **Do not use petroleum based cleaners on the front panel.**

If required, the 2734A interior may be cleaned by blowing with dry compressed air.

If the 2734A has become "heavily" contaminated with dirt or by other contaminant(s) then it is recommended that the unit be completely overhauled (contact your local Valhalla Scientific Service Center for details).

9.3 Troubleshooting

The following paragraphs give basic procedures for troubleshooting and component replacement in the 2734A. Before attempting to fault find the 2734A it should be noted that the Reference Enclosure contains no user replaceable parts but are replaced by Valhalla Scientific Inc. directly on an exchange basis.

9.3.1 Component Replacement

The 2734A accuracy and reliability can only be maintained if the following precautions are taken when changing a component:

- a) Only use the specified component or exact equivalent. Spare parts can be ordered from your nearest Valhalla Scientific Service Center by the Valhalla part number listed in the parts list in Section XIV of this manual. Please provide the type and serial number of the unit with your order.
- b) Only use 63/37 rosin core electronic grade solder with a 50W (or lower) maximum power soldering iron.
- c) Always use extreme care when removing or inserting components.

9.3.2 Finding the Faulty Component

Upon diagnosing that any fault exists within the 2734A the user should first check the fuses and connectors, if these are found to be in good order then the user follow normal fault finding procedures to check the power supply module (on the rear panel) and the internal batteries. If none of these are found to be the cause, then the fault lies within the Reference Enclosure which contains no user replaceable parts and must be exchanged with a new (or renovated) Enclosure from Valhalla Scientific Inc. directly.

SECTION X - THEORY OF OPERATION

10.1 General

The 2734A Reference Enclosure does not contain any user replaceable parts, thus a description of the circuitry contained within this enclosure is not given here. The remaining circuitry consists of a basic pair of IC regulators providing the battery charging supply and the +18V supply used for the electronics within the 2734A. No detailed description of the operation is required, the user is referred to the manufacturers data sheets for details on the operation of the IC regulators.

SECTION XI - PERFORMANCE VERIFICATION

11.1 General

Verification of the performance of the 2734A may be performed at any time, and is especially recommended following receipt of the unit or following transportation. Verification may be achieved with two levels as follows :

11.2 Verification of Operation

To verify that the 2734A is in operational condition, the following procedure should be followed. If any test fails then no further test should be performed and the 2718A should be set aside for maintenance.

- i) Ensure that the AC power switch of the 2734A is in the OFF position.
- ii) Apply AC power to the 2734A (connector is on the rear panel).
- iii) Press the 2734A AC power switch to the ON position (the switch is located within the AC power connector, ON is with the "1" depressed). The AC ON LED on the front panel should illuminate, the BATTERY CHARGING LED will illuminate if the AC power was removed for more than 1 minute.
- iv) Ensure that the rear panel OVEN MODE switch is in the OPERATE position and that the front panel TRANSIT LED is extinguished.
- v) Allow 2734A to warm up for 1 hour.
- vi) Ensure that the front panel OVEN READY LED is illuminated, the OVEN FAULT LED is extinguished and that the BATTERY O.K. LED is illuminated.
- vii) With a known operational DC voltmeter having better than 0.01% accuracy check that the each output on the 2734A is within 0.04%.
- viii) Turn the rear panel AC power switch off ("0" depressed) or remove the power cord. The AC ON LED should extinguish (this may take a few seconds), the BATTERY CHARGING LED should extinguish, the OVEN READY LED should remain illuminated and the OVEN FAULT LED should remain extinguished. Repeat test vii).
- ix) Apply a DC power source of 30 to 40V with 1 amp capability to the rear panel terminals (carefully observe the polarity) via an ammeter on its 1 (or 2) Amp range. Check that the conditions of test viii) remain valid and that the 2734A is drawing less than 1 Amp but more than 0.05 Amp from the DC power source.

After successful completion of all the above steps the 2734A is fully operational with no faulty parts apparent.

11.3 Verification of Specification

Before attempting to prove that the 2734A is performing to specification the user must be aware of the following points:

The 2734A is a very high precision unit having specifications equivalent to the absolute accuracy of many good quality DC Standards Laboratories, its accuracy must be checked against standards whose accuracy (or inaccuracy) is known to be at least 3:1 better than the 2734A specifications.

When a comparison is made, as it is here, the uncertainty of the users standards and equipment must also be added to the specifications. In cases where the 2734A was not locally calibrated and the National Standards differ from the NBS (i.e. U.S.A.) standards then this difference must also be accounted for.

Prior to specification verification it is recommended that the user familiarizes himself with the operation of the 2734A and allows at least 24 hours (preferably 48 hours) for the unit to settle while powered.

If the 2734A is found to be fully operational but not performing to specification then contact your nearest Valhalla Scientific Service Center before returning the unit for repair or attempting repair yourself.

SECTION XII - USEFUL HINTS

12.1 Getting The Most Out of Your 2734A

As with all precision instrumentation there are some general "caretaking" procedures that will help the user obtain even better performance than that specified. Most of the points listed below are good habits for any equipment, and if followed should also enhance all of the user equipments' performance and reliability at minimal cost.

i) Leave equipment powered at all times. This greatly reduces the drift and unreliability caused by temperature stresses during warm-up and cool-down.

ii) Avoid operating equipment in direct sunlight (e.g. through a window). Very high surface temperatures can be reached and the highly uneven temperature distribution will considerably affect the performance and reliability of the equipment.

iii) Avoid operating equipment directly under an air-conditioning outlet duct. This will cause similar affects as in ii) above. If there is significant air movement over the terminals then cover them and the cabling by a cloth cover (not synthetic - static will cause worse problems).

iv) Avoid other causes of temperature shock. If it is necessary to transport equipment then always ensure that it is well packed and thermally lagged. Also ensure that no rain or condensation can penetrate into the equipment.

v) Avoid static electricity. Discharges into the case or terminals of equipment can cause damage and will certainly cause noisy measurements to be made. Even a charged body (e.g. a person) which is moving can cause noise if impedance levels are significant, thus always sit or stand on a conductive surface and avoid movement whenever sensitive measurements are being made.

vi) Avoid high energy electro-magnetic fields. Although modern equipment is relatively insensitive to fields, they will produce errors. Always use shielded cabling wherever possible and always ensure that the shield is connected to a low impedance node.

vii) Always use the highest quality cables. Many "good looking" cables do not actually use pure copper for conductors and can cause many microvolts of thermal emf's. Also many banana jacks are actually made of steel or similar material and can cause several tens of microvolts of thermal emf's. If you are unsure then try reversing your connections and compare the measurements.

viii) Keep connectors and cables clean and free from grease. Corrosion can cause what was a perfectly good, high quality connector to become one that is worse than a "cheap" one. Surface grease will collect moisture and further grease, and also produce a significant leakage path. This can seriously affect high impedance and/or high accuracy measurements.

ix) Keep handling of terminations and cabling to a minimum. This reduces grease build up on these items (as in viii above) and also reduces the errors caused by thermal emf's.

x) Always try to "balance" cabling. Even with the highest quality cabling and terminals several microvolts of thermal emf's can occur if there is significant temperature difference. Thus always use the same gauge and type of wire to both terminations of sensitive measuring and generating devices (such as the 2734A) to reduce the temperature differential between conductors. Care in balancing the routing of cables (i.e. route the Hi and LO terminal connections close together) will also reduce thermals and pick up of interference.

xi) Do not "stack" equipment on top of each other. Most equipment require air flow around them and any restriction will decrease the performance, also the top instrument in a "pile" of several can be 10 or even 20 degrees hotter than the bottom one.

xii) Treat your equipment correctly and it will treat you correctly. Keep equipment clean, do not attempt any measurement that could yield damaging out of specification voltages or currents without protecting the instrumentation, and the equipment should perform well within specification for many years. Frequent breakdowns can be due to faulty equipment or design, but are more often caused by a lack of care and/or understanding of the product.

12.2 Dielectric Storage in Cabling

The effect of dielectric storage in cabling is often overlooked by many users but can have significant effects on the accuracy or repeatability of measurements. All cables have dielectric storage. Many people believe that there a relationship between dielectric storage and the published loss (also called dissipation factor) data for cables and capacitors. The answer is that there is and there is not! There are two major effects in dielectric storage:

- i) The initial stored quantity.
- AND
- ii) The time constant of the discharge.

Dielectric storage (or absorption as it is also called) can be simulated by placing a very small capacitance in series with a very large resistance in parallel with the actual capacitance of the cable (or capacitor). The initial stored quantity is dependent on the value of the "very small capacitance" while the time constant is dependent on this and the "very high resistance". In practice most materials behave as if they had several of these capacitor/resistor combinations with widely varying values and time constants.

In practice the use of polyethylene insulated cables (never use PVC or Teflon) will help with this effect.

If the user is unsure, or just wishes to see the effect, then try the following test on a two-conductor cable. The user is warned that this can be a dangerous test to the user, extreme caution must be exercised.

- i) Ensure that neither end of the cable has any connections and are not shorted.
- ii) Connect one end of the cable across a 100V (approx.) DC source and leave for several minutes.

iii) Connect a 1 megohm resistor across the input terminals to a DVM with 1 μ V sensitivity and a reading rate of greater than 1 per second. Allow sufficient time for the reading to settle.

iv) Very carefully and quickly disconnect the cable from the 100V DC supply (do not set to zero or standby first) and connect instead to the DVM and 1Mohm. The user will see many microvolts (millivolts for bad cables) of reading which may take several minutes to decay.

If the user wishes, the DVM and 1Mohm (if high enough wattage) may be connected to the cable all of the time, in which case the dielectric storage of the DVM (as well as the cable) will be measured.

The effect of this is most visible in resistance measurements, particularly at higher values (above 10Kohm), but is also very noticeable when performing measurements of standard cells or the outputs of voltage dividers. In both of these cases the impedance levels are quite high and very long settling times can result if "bad" cabling is used.

SECTION XIII - MANUAL CHANGE INFORMATION

13.1 General

This section contains manual change information. If no addendums appear following this page, your manual is correct as printed.

SECTION XIV - SCHEMATIC AND ASSEMBLY DIAGRAMS

14.1 General

The illustrations of this section are the schematic and assembly diagrams of the 2734A. To the extent practical, an assembly diagram is adjacent to the appropriate schematic diagram. All diagrams are reductions of factory engineering drawings.

NOTES: (UNLESS OTHERWISE SPECIFIED)

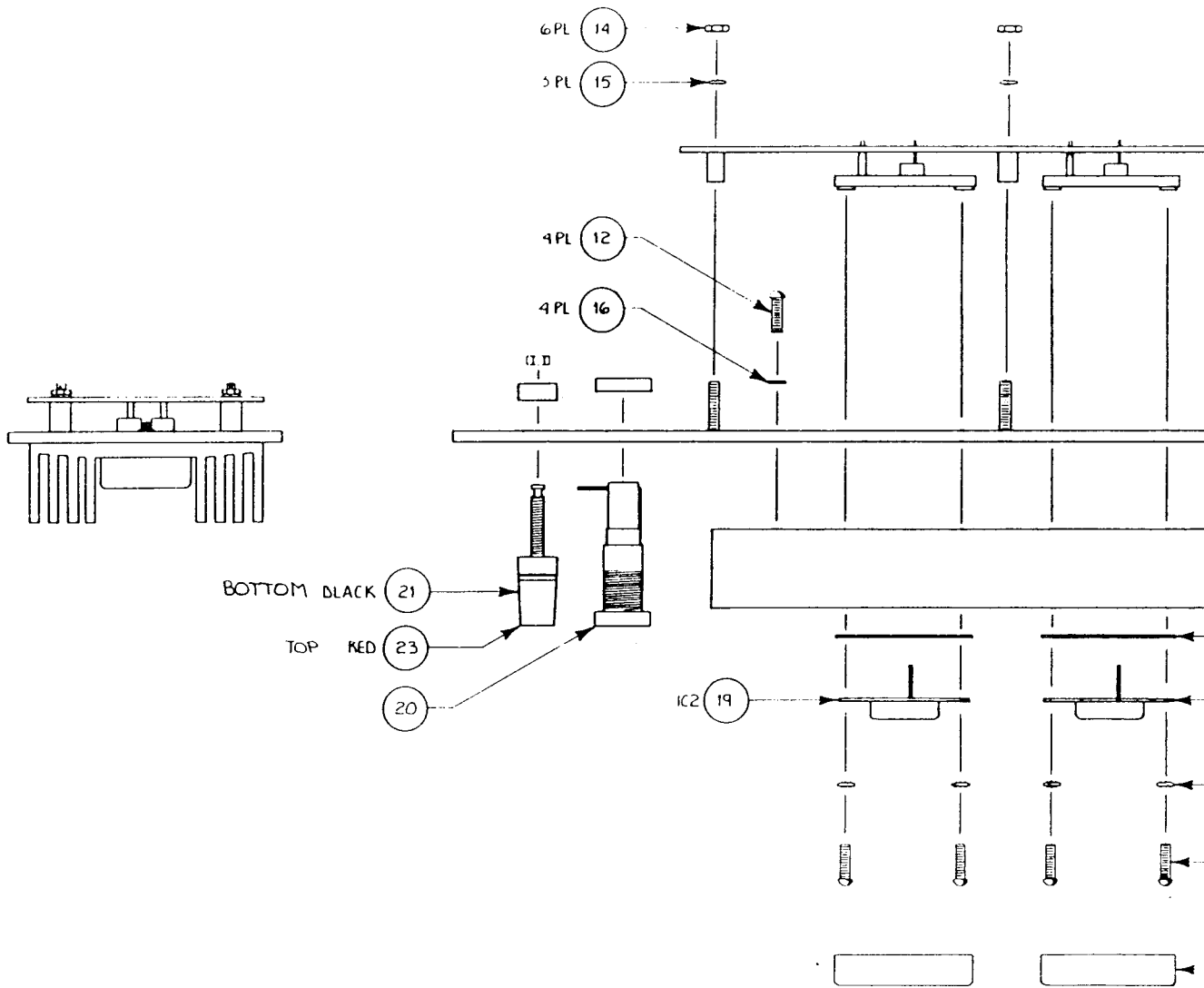

REVISIONS				
ECO	LTR	DESCRIPTION	DATE	APPROVED
939	A	RELEASED	MAS 7/19/86	SM
	B	UPDATED	MAS 12-17-86	CRE

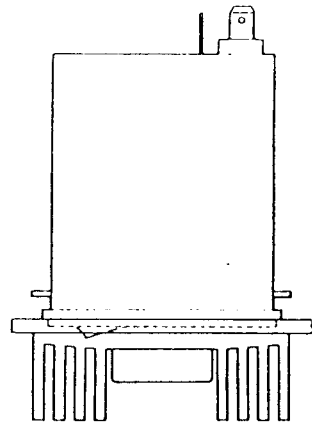
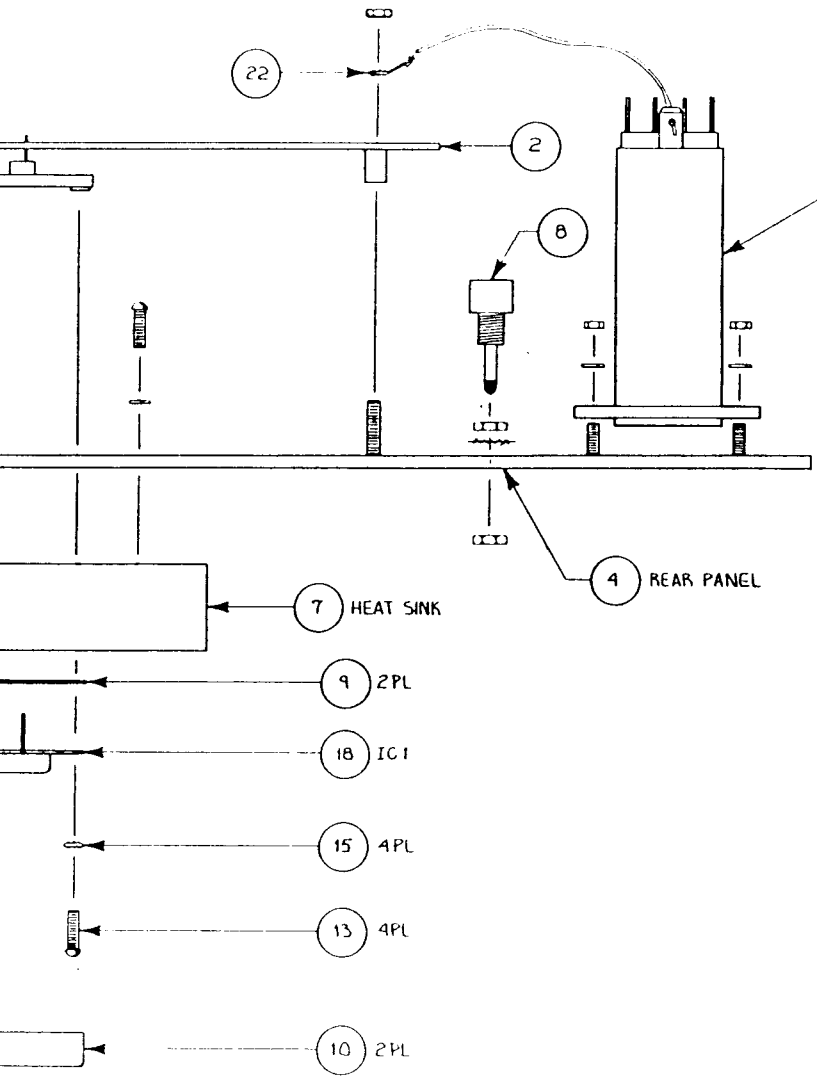

				TOLERANCES X = ± .00" XX = ± .03" XXX = ± .010"	MATERIAL /	DRAWN MAS 12/16/85 CHECKED CRE 1-14-86 APPR SM 7/17/86 STK NO.	 Valhalla Scientific Inc. SAN DIEGO, CA					
				FINISH /	2734A REAR PANEL ASSY.							
				BREAK ALL SHARP CORNERS AND EDGES. MACH SURFACES 64 ✓					SCALE 1:1 SHEET 1 OF 2	CODE IDENT 53504 SIZE D	DRAWING NO 2734-402	REV B
DASH NO	QTY RECD	NEXT ASSEMBLY	USED ON									

NOTES: Unless otherwise specified

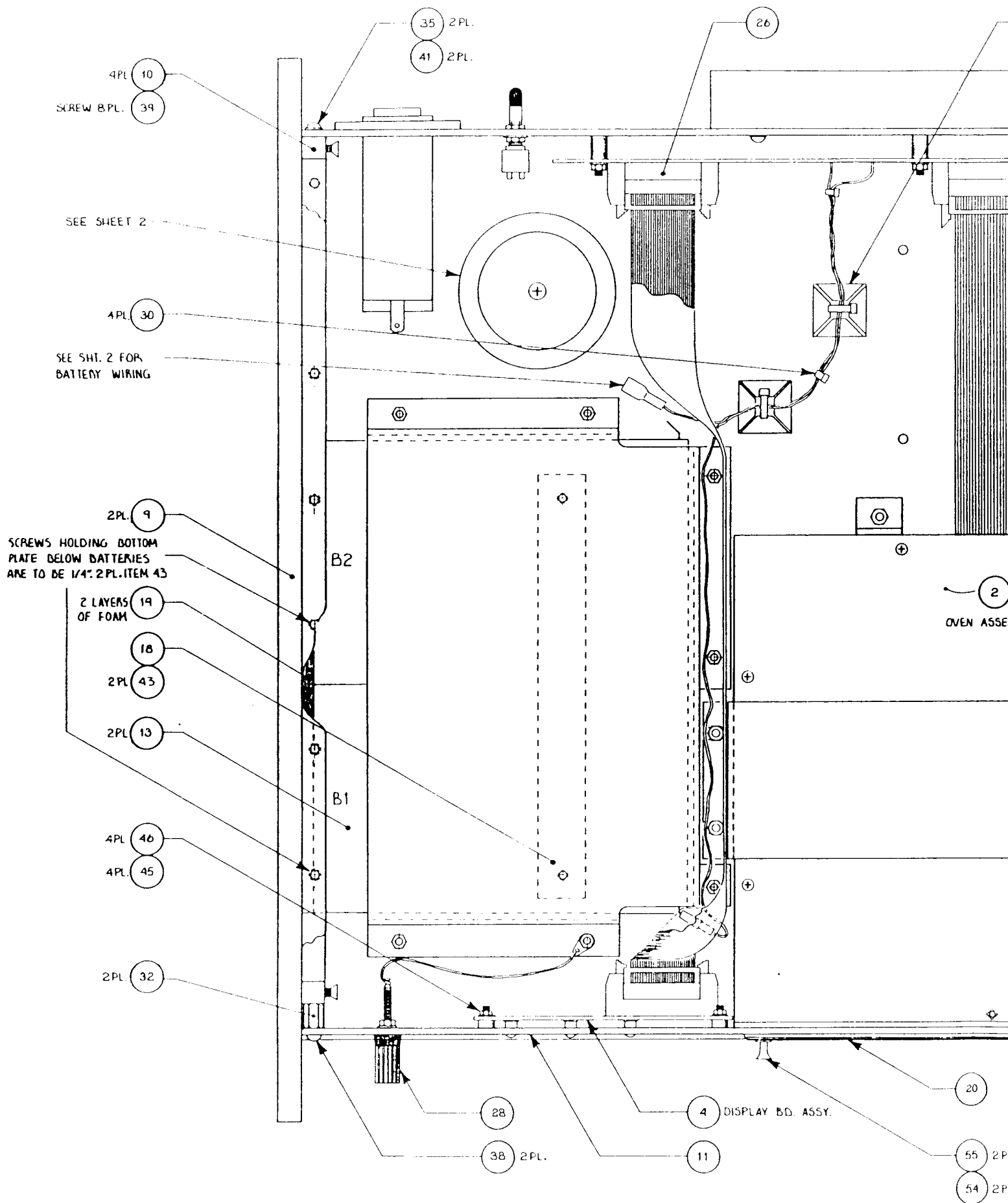

REVISIONS				
ECR#	LTR	DESCRIPTION OF CHANGE	DATE	APPROVED
	A	RELEASED	MAS 7/16/86	<i>[Signature]</i>
940	B	UPDATED WITH NEW BATTERIES	MAS 12-16-86	CRE

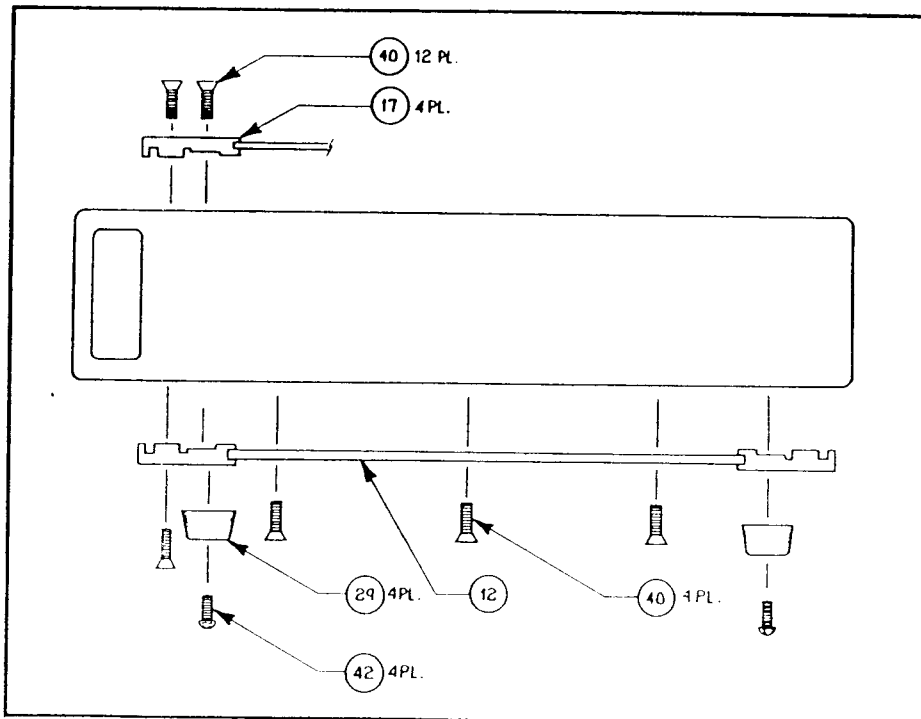
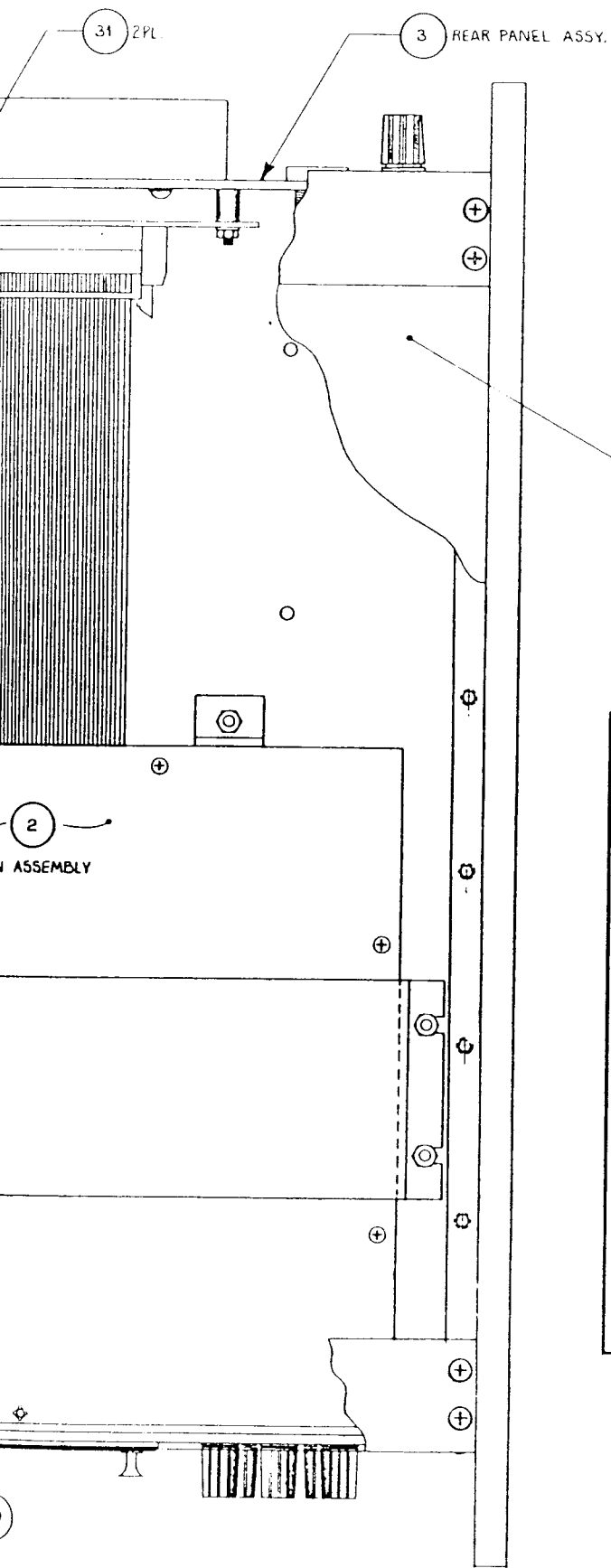

2 PL.

2 PL.

TOLERANCES: X° = ± .30' .XX = ± .02 XXX = ± .005	MATERIAL: 	DRAWN BY M. SCHAEFFER 1/21/85	 VALHALLA SCIENTIFIC 9955 MESA RIM ROAD, SAN DIEGO, CA 92121
		CHECKED BY CRE 2-18-86	
DEBURR AND BREAK ALL SHARP EDGES AND CORNERS	FINISH: 	APPROVED BY <i>[Signature]</i> 7-17-86	TITLE 2734A CHASSIS ASSEMBLY
MACHINED SURFACES ARE TO HAVE A FINISH OF 63		SCALE: 1:1	STOCK NO. NONE
		SHEET 1 OF 5	REV: B

NOTES: Unless otherwise specified

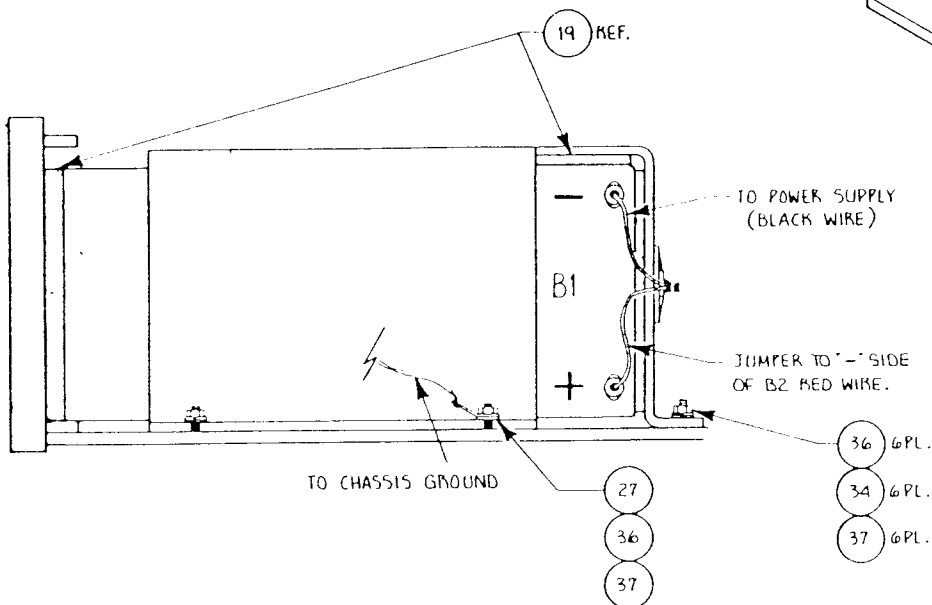
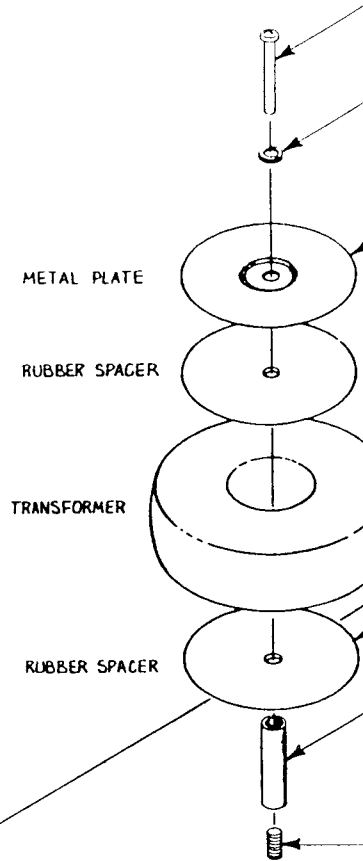
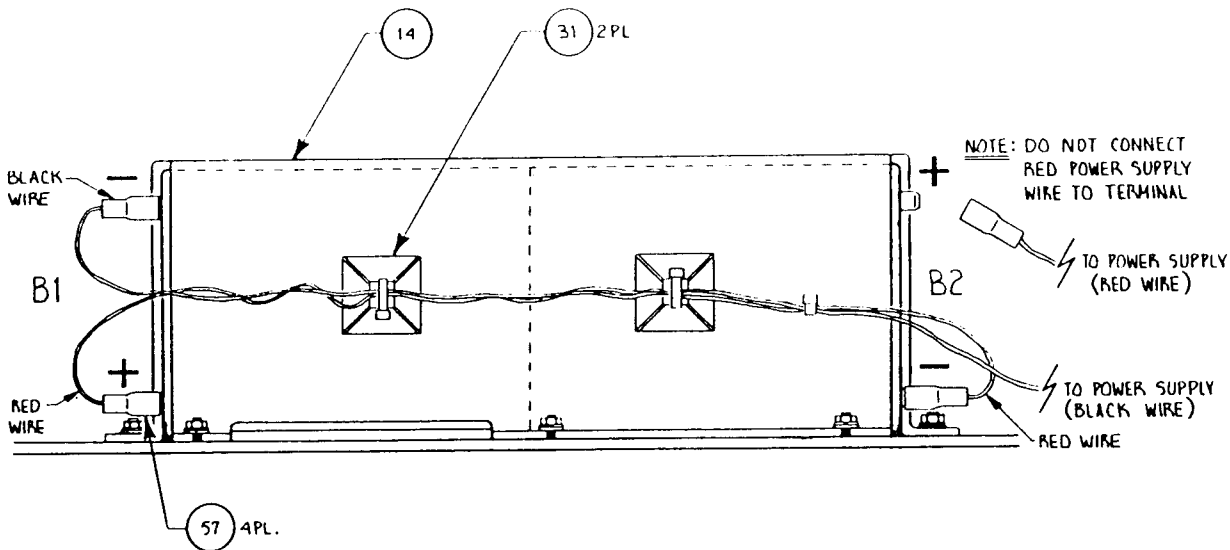

REVISIONS				
ECR	LTR	DESCRIPTION OF CHANGE	DATE	APPROVED
		SEE SHEET ONE	MAS 12-16-86	<i>[Signature]</i>

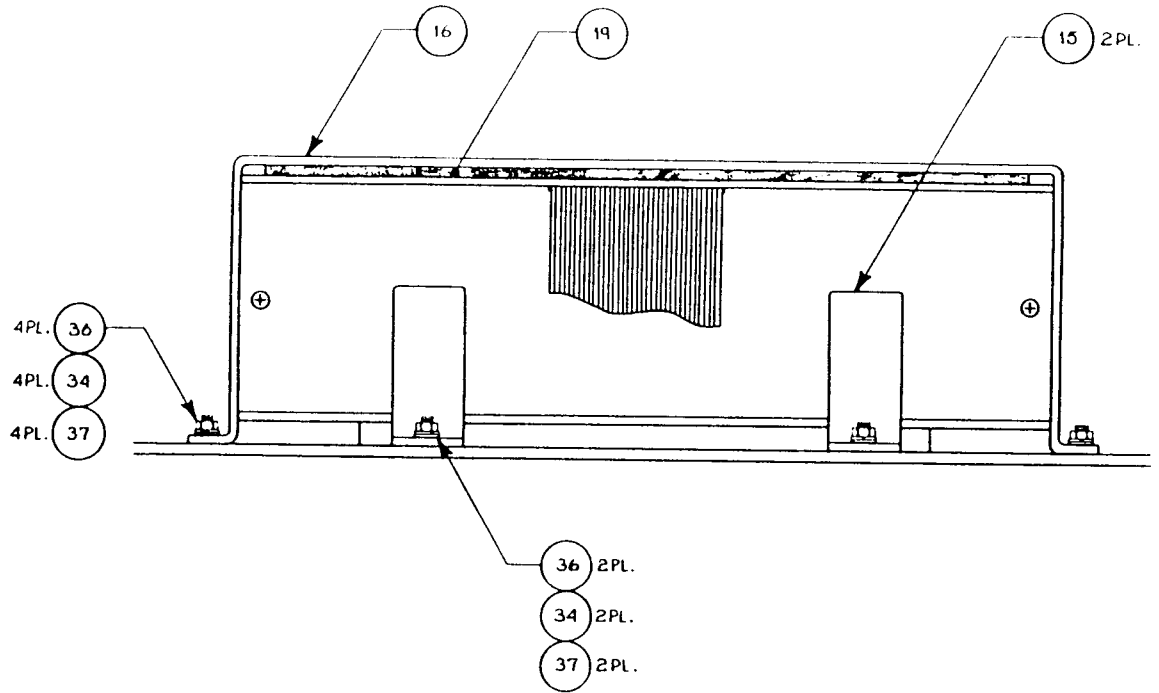
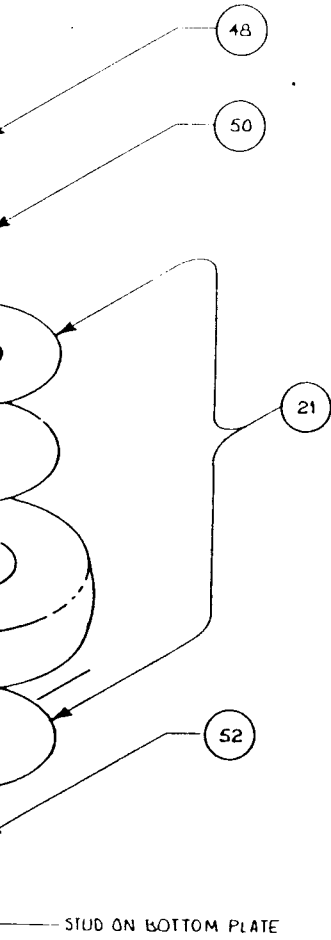

TOLERANCES: X° = ± .30' .XX = ± .02 .XXX = ± .005	MATERIAL: 	DRAWN BY M. SCHAFER 1/21/85	 VALHALLA SCIENTIFIC 9955 MESA RIM ROAD, SAN DIEGO, CA 92121
		CHECKED BY C. R. C. 2-18-86	
DEBURR AND BREAK ALL SHARP EDGES AND CORNERS	FINISH: 	APPROVED BY <i>[Signature]</i> 7-17-86	TITLE 2734A CHASSIS ASSY.
MACHINED SURFACES ARE TO HAVE A FINISH OF 63/		SCALE: 1:1 SHEET 2 OF 5	STOCK NO. NONE
			REV: B

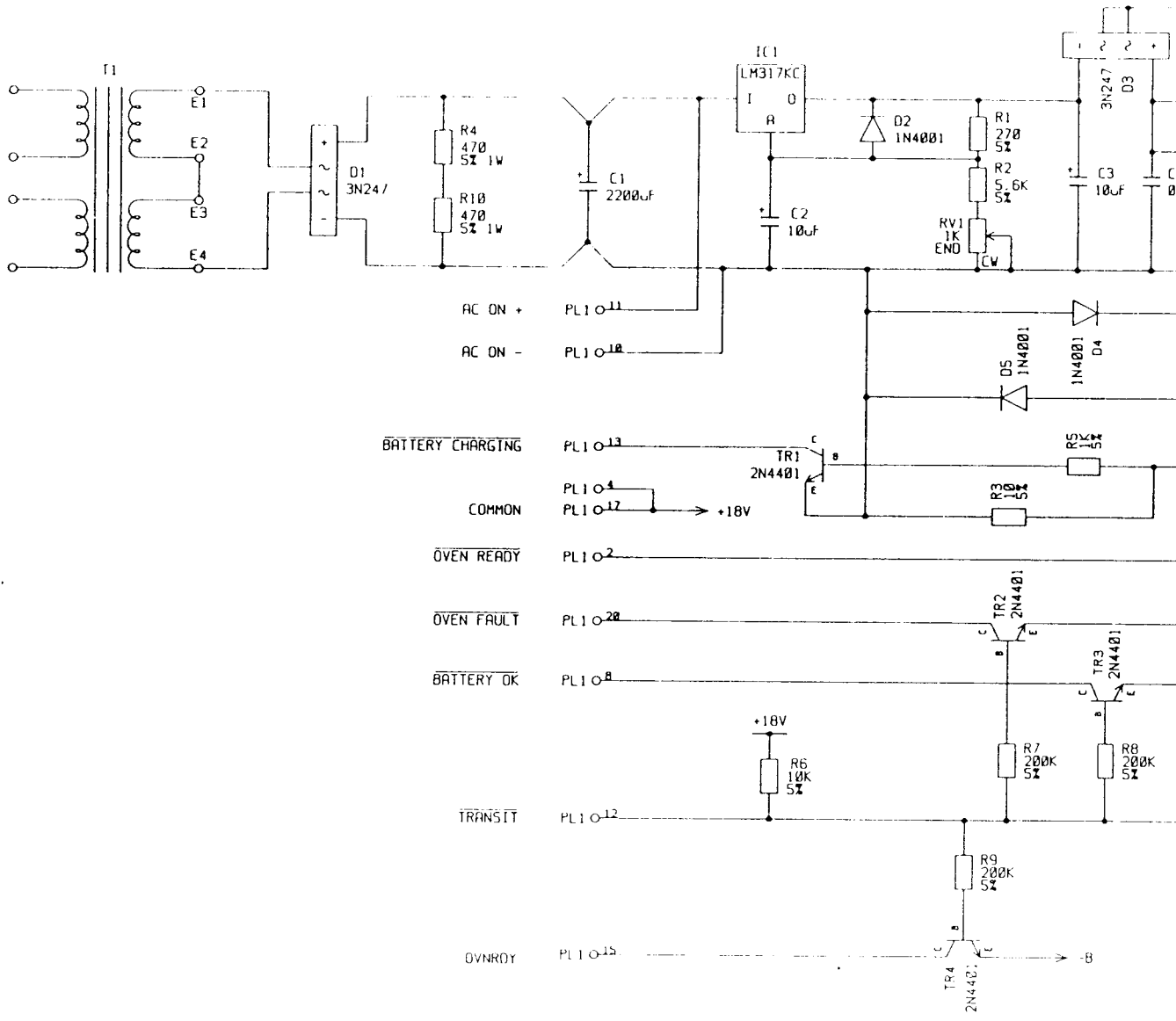

REVISIONS				
ECR#	LTR	DESCRIPTION OF CHANGE	DATE	APPROVED
	A	RELEASED	RON 7-21-86	

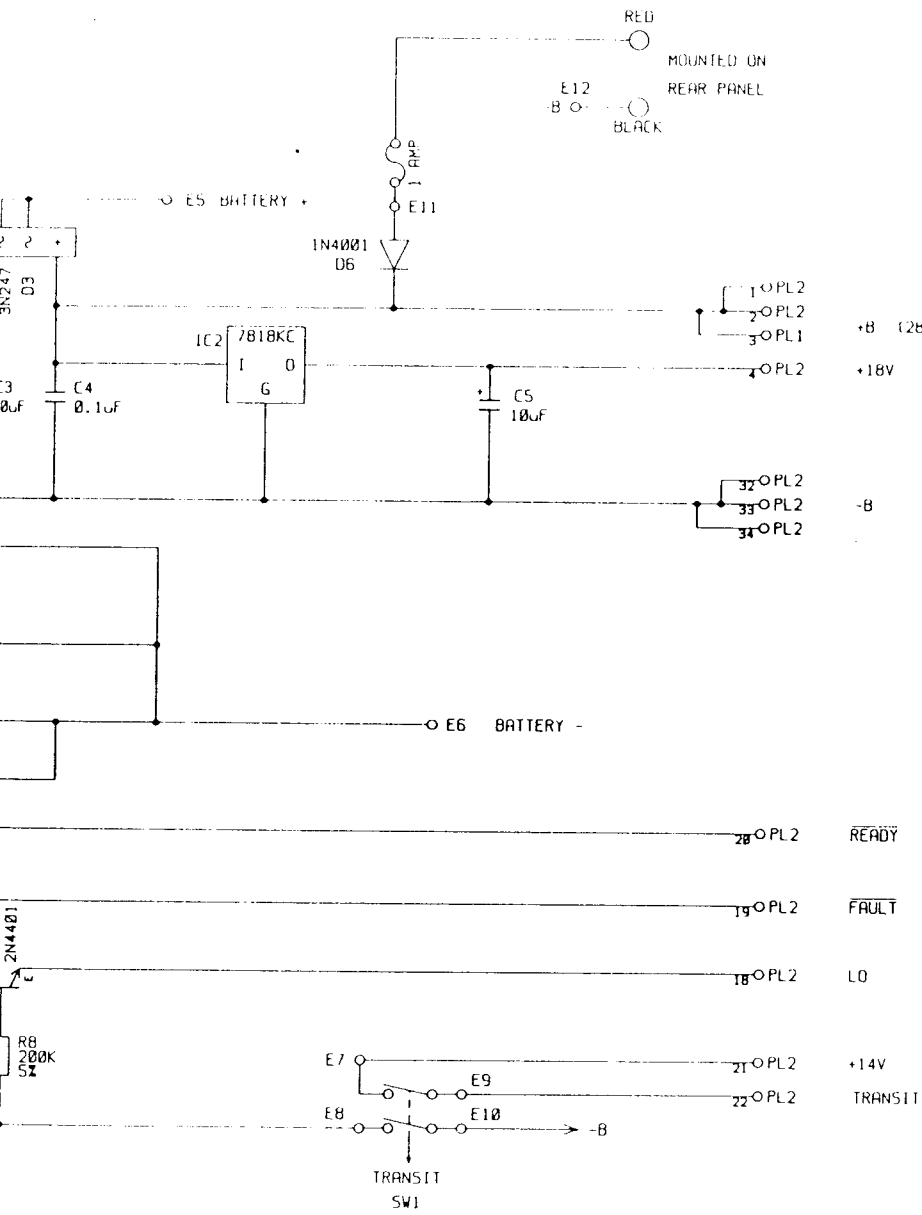

TR1		TR4
T1		T1
SW1		SW1
RV1		RV1
R1		R10
IC1		IC2
F1		F1
D1		D6
C1		C5
LAST USED	NOT USED	FIRST USED

DRAWN BY
R. NIEMELA
7-21-86

CHECKED BY
[Signature]
8/1/86

APPROVED BY
[Signature]
8-2-86

THE INFORMATION DISCLOSED
HEREIN WAS OBTAINED BY AND
IS THE PROPERTY OF VALHALLA
SCIENTIFIC INC. AND EXCEPT
FOR RIGHTS EXPRESSLY GRANTED
TO THE UNITED STATES GOVERNMENT
BY VALHALLA SCIENTIFIC INC.,
RESERVES ALL PATENT, TRADE
MARK, PROPRIETARY DESIGN, MANUFACTURE
ORIGIN, USE AND REPRODUCTION
RIGHTS THEREOF.

VALHALLA
SCIENTIFIC

9955 MESA RIM RD. SAN DIEGO, CA 92121

TITLE
2734 A POWER
SUPPLY BOARD

SHEET 1 OF 1

DRAWING NO.
2734-074

REV.
A

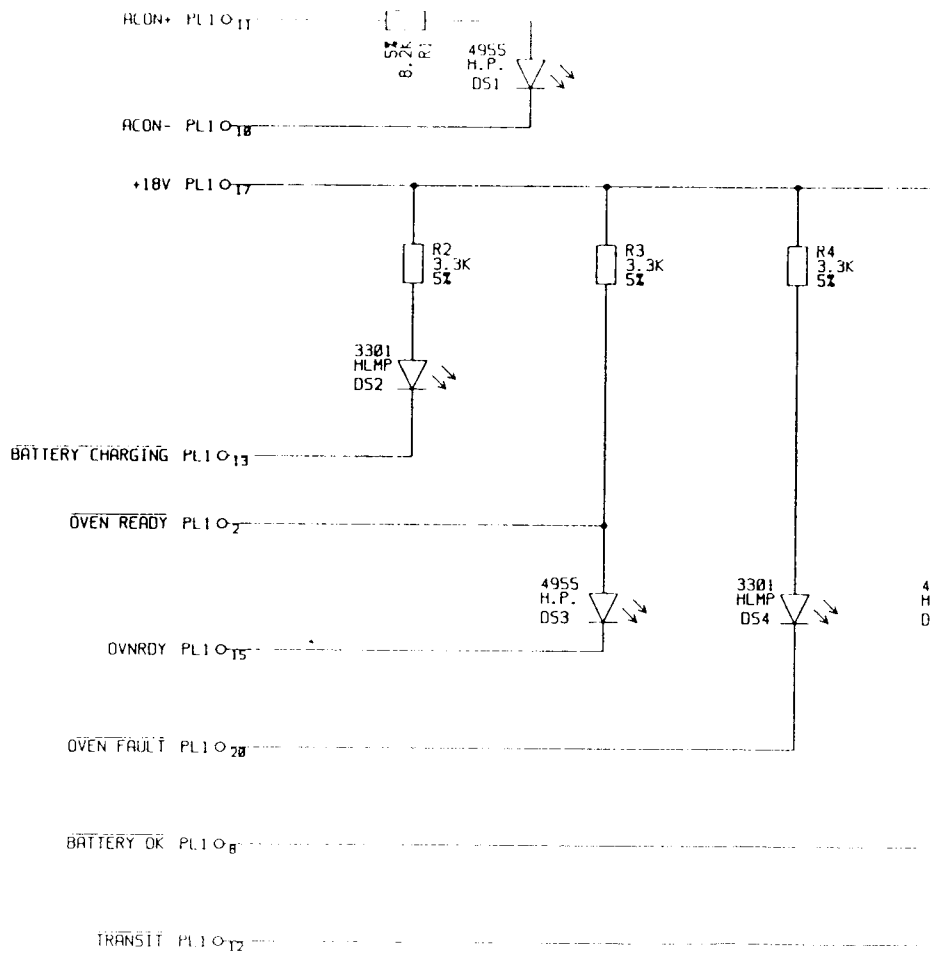

REVISIONS				
ECR#	LTR	DESCRIPTION OF CHANGE	DATE	APPROVED
	A	RELEASED		

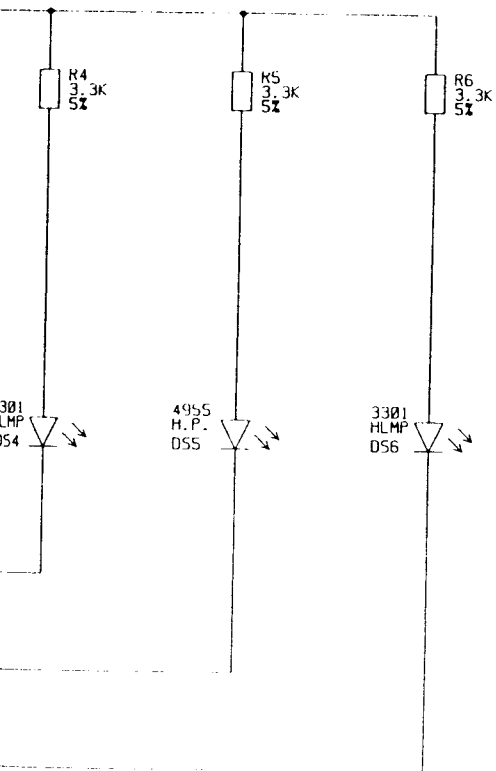

DRAWN BY R. NIEMELA	7/29/86	VALHALLA SCIENTIFIC 9955 MELBA KIM RD., SAN DIEGO, CA 92121
CHECKED BY <i>SW</i>	8/6/86	
APPROVED BY <i>TS</i>	8/6/86	
<small>THE INFORMATION DISCLOSED HEREIN WAS ORIGINATED BY AND IS THE PROPERTY OF VALHALLA SCIENTIFIC INC. AND EXCEPT FOR RIGHTS EXPRESSLY GRANTED TO THE UNITED STATES GOVERNMENT VALHALLA SCIENTIFIC INC. RESERVES ALL PATENT, TRADE PROPRIETARY DESIGN, COPYRIGHT, MASKING USE AND REPRODUCTION RIGHTS THEREOF.</small>		TITLE 2734A DISPLAY BOARD SCHEMATIC
SHEET 1 OF 1		DRAWING NO. 2734-075
		REV A

NOTES: Unless otherwise specified

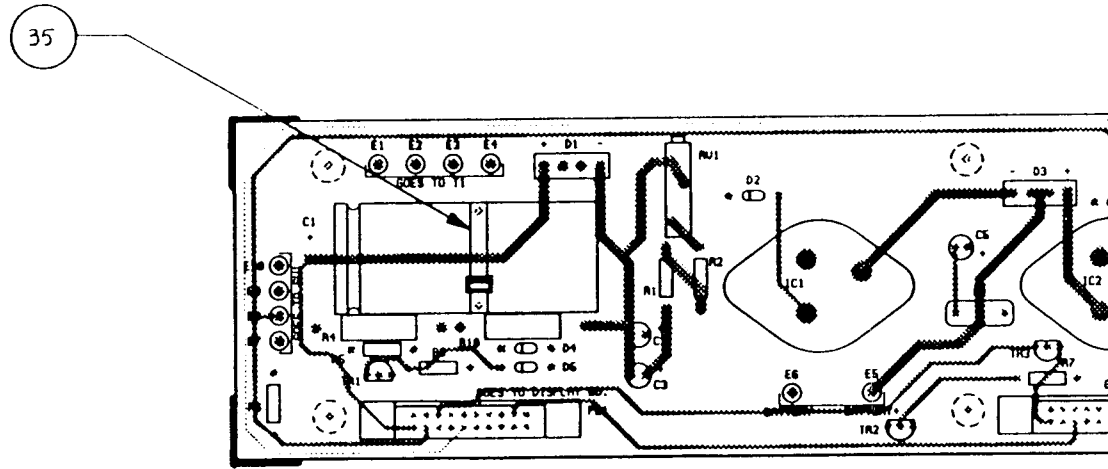
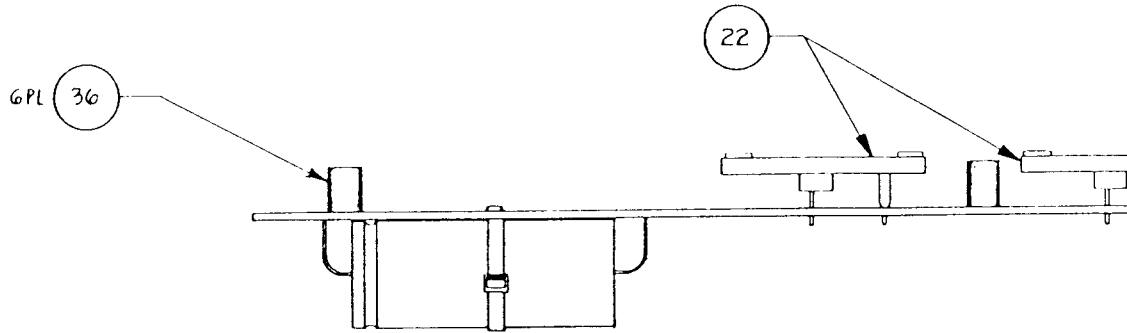

TOLERANCE	
X°	= ±
.XX	= ±
.XXX	= ±
DEBURR BREAK SHARP ED AND CORN	
MACHIN SURFACES TO HAV FINISH O	

REVISIONS				
ECR #	LTR	DESCRIPTION OF CHANGE	DATE	APPROVED
	A	RELEASED	MAS 8/11/86	JW
912	B	MADE P/L CHANGE	MAS 8/13/86	PO

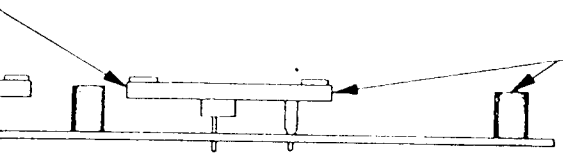

SPACERS AND SOCKETS ARE MOUNTED ON THE SOLDER SIDE OF BOARD.

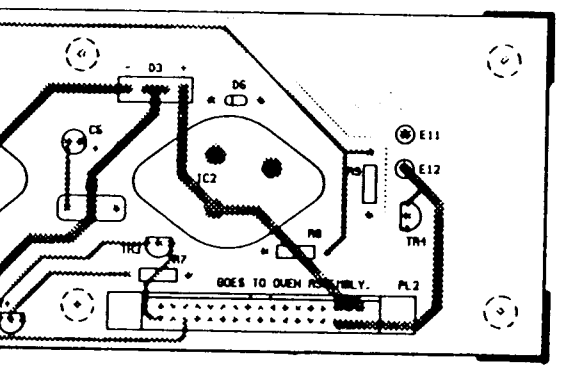

TOLERANCES: X° = ± 30' .XX = ± .02 .XXX = ± .005	MATERIAL: 	DRAWN BY M. SCHAFFER 8/11/86	VALHALLA SCIENTIFIC 9955 MESA RIM ROAD, SAN DIEGO, CA 92121		
		CHECKED BY CRE 8-12-86			
DEBURR AND BREAK ALL SHARP EDGES AND CORNERS	FINISH: 	APPROVED BY 8-13-86		TITLE 2734A POWER SUPPLY ASSY.	
MACHINED SURFACES ARE TO HAVE A FINISH OF 63√		<small>THE INFORMATION CONTAINED HEREIN IS UNCLASSIFIED AND IS THE PROPERTY OF VALHALLA SCIENTIFIC, INC. AND EXCEPT FOR RIGHTS EXPRESSLY GRANTED TO THE UNITED STATES GOVERNMENT THROUGH BUSINESS AND SERVICES ALL PATENT, TRADE SECRET, PROPRIETARY DESIGN, MANUFACTURING USE AND REPRODUCTION RIGHTS THEREOF.</small>		SCALE: NONE	STOCK NO. NONE
		SHEET 1 OF 3			

NOTES: Unless otherwise specified

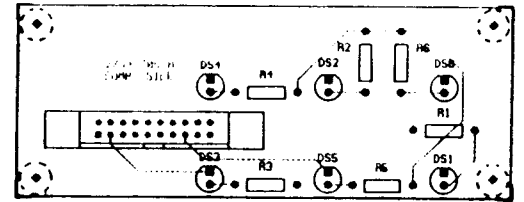
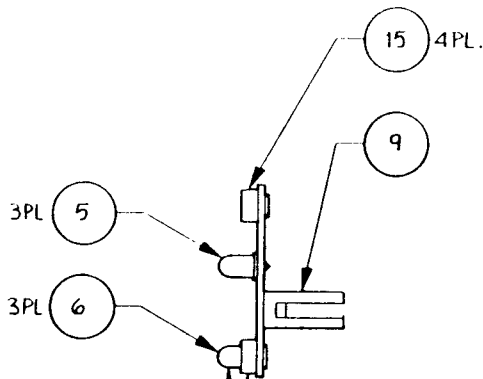

LED'S AND SWAGE-INS ARE MOUNTED ON SOLDER SIDE OF PCB.

TOLERANCES:	
X°	= ± 3°
.XX	= ± .01
.XXX	= ± .005
DEBURR AND BREAK ALL SHARP EDGES AND CORNERS	
MACHINED SURFACES TO HAVE A FINISH OF 6.3	

REVISIONS				
ECR#	LTR	DESCRIPTION OF CHANGE	DATE	APPROVED
	A	RELEASED	MAS 8/5/86	

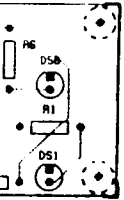

TOLERANCES: X" = ± .30' .XX = ± .02 .XXX = ± .005	MATERIAL: 	DRAWN BY M. SCHAEFFER 5/8/86	 VALHALLA SCIENTIFIC 9955 MESA RIM ROAD, SAN DIEGO, CA 92121			
		CHECKED BY CRE 8-7-86				
DEBURR AND BREAK ALL SHARP EDGES AND CORNERS	FINISH: 	APPROVED BY SM 8/1/86		TITLE 2734A DISPLAY BOARD ASSY.		
MACHINED SURFACES ARE TO HAVE A FINISH OF 63/		<small>THE INFORMATION DISCLOSED HEREIN HAS BEEN OBTAINED BY AND IS THE PROPERTY OF VALHALLA SCIENTIFIC, INC. AND IS NOT TO BE DISCLOSED OR REPRODUCED IN ANY MANNER WITHOUT THE WRITTEN PERMISSION OF VALHALLA SCIENTIFIC, INC. RESERVED ALL PATENT, TRADE, COPYRIGHT, DESIGN, SERVICE MARK, AND REPRODUCTION RIGHTS THEREOF.</small>	SCALE: 1:1	STOCK NO. NONE	DRAWING NO. 2734-605	REV: A
		SHEET 1 OF 2				



PARTS LIST

2734A CHASSIS ASSY.

MODEL 2734A

DWG NO 2734-400

REV B

#	REF DES	VALHALLA PART NO	DESCRIPTION	CODE IDENT	MFG PART NO	QTY.			REMARKS
						I	N	I	
47									
48		90-08000	SCREW, PHIL, PAN, S.S.		B-32x1/2	1			
49									
50		98-08001	WASHER, SPLIT LOCK		#8	1			
51									
52		5-10026	STANDOFF 1/4 DIA. 3/4 LG. #8	SMITH	2128	1			
53									
54		5-10505	FASTENER, PUSH, PULL, PLUNGER, BLK	NYLATCH	HN3P-34-4-1	2			
55		5-10506	FASTENER, PUSH, PULL, GROMET, BLK	NYLATCH	HN3G-34-1	2			
56									
57			DISCONNECT, FEMALE, RED		18-22 AWG	4			ECR#940
58	F1	5-04002	1 AMP SLO BLO FUSE	LITTLE FUSE	313-001	1			ECR#940
59	F2	5-04007	0.5 AMP SLO BLO FUSE	LITTLE FUSE	313-.500	1			ECR#940
60		80-01516	16 AWG WIRE, GRN, PVC			5"			ECR#940
61		80-02920	20 AWG WIRE, WHT, TFE			3"			ECR#940
62		80-02720	20 AWG WIRE, VLT, TFE			3"			ECR#940
63		80-02820	20 AWG WIRE, GRY, TFE			3"			ECR#940
64		80-02120	20 AWG WIRE, BLK, TFE			26"			ECR#940
65		80-02220	20 AWG WIRE, RED, TFE			20"			ECR#940
66									
67		70-00002	1/8" BLK. SHRINK TUBING			2"			ECR#940
68		70-00004	1/4" BLK. SHRINK TUBING			4"			ECR#940
69									

NOTES:

SHT 5 OF 5



PARTS LIST

2734A CHASSIS ASSY.

MODEL 2734A

DWG NO 2734-400

REV B

#	REF DES	VALHALLA PART NO	DESCRIPTION	CODE IDENT	MFG PART NO	QTY.		REMARKS
						I	N	
24								
25								ECR#940
26		5-10540	CABLE 20 PIN 16' IDS CONN.	VALHALLA	2734-051	1		
27		5-10086	SOLDER LUG, #6, INT STAR	SMITH	1412-6	1		
28	J1	5-10137	BINDING POST, GOLD	SMITH	1518	1		
29		5-10015	FOOT, RUBBER, WHITE	ACCURATE RUBBER	2089W-017	4		
30		5-10019	CABLE TIE 4"x1/8"	PANDUIT	WRN-4	6		ECR#940
31		5-10441	TIE WRAP BLOCK SMALL	PANDUIT	ABMM-AT	4		ECR#940
32		5-10436	STANDOFF, 1/4 HEX, 7/16, 6-32, M-F	RAF	4533-632-SS-0	2		
33								
34		98-06001	WASHER, SPLIT LOCK		#6	12		ECR#940
35		98-06002	WASHER INT. STAR		#6	2		
36		98-06000	WASHER FLAT		#6	13		ECR#940
37		97-06001	NUT, RADIO HEX		6-32	13		
38		90-06204	SCREW, PHIL, PAN, BLACK		6-32x1/4	2		
39		91-06009	SCREW PHIL FLAT 82°		6-32x9/16	8		
40		91-06006	SCREW PHIL FLAT 82°		6-32x3/8	16		ECR#940
41		90-06006	SCREW PHIL PAN S.S.		6-32x3/8	2		
42		90-06009	SCREW PHIL PAN S.S.		6-32x9/16	4		
43		91-06004	SCREW PHIL FLAT 82°		6-32x1/4	4		ECR#940
44								
45		98-04002	WASHER INT. STAR		#4	4		
46		97-04001	NUT RADIO HEX		4-40	4		

NOTES:

SHT 4 OF 5



PARTS LIST

2734A CHASSIS ASSY.

MODEL 2734A

DWG NO
2734-400

REV
B

#	REF DES	VALHALLA PART NO	DESCRIPTION	CODE IDENT	MFG PART NO	QTY.				REMARKS
						I	N	I	N	
1										
2			2734A OVEN ASSEMBLY	VALHALLA	2734-401	1				
3			2734A REAR PANEL ASSY.	VALHALLA	2734-402	1				
4			2734A DISPLAY BD. ASSY.	VALHALLA	2734-605	1				
5										
6										
7										
8										
9		4-10458	SIDE RAIL	VALHALLA	2724-215	2				
10		4-10332	CORNER BLOCK	VALHALLA	2724-204	4				
11		4-10629	FRONT PANEL	VALHALLA	2734-100	1				
12		4-10620	BOTTOM PLATE	VALHALLA	2734-208	1				
13	B1, B2	5-10613	BATTERY. 12V. 6.5AH. LEAD ACID	PANASONIC	LCR12V6.5P	2				ECR 940
14		4-10704	BATTERY STRAP	VALHALLA	2734-221	1				ECR# 940.
15		4-10615	BATTERY AND REF. STOP	VALHALLA	2734-203	2				
16		4-10613	OVEN HOLD DOWN STRAP	VALHALLA	2734-201	1				
17		4-10333	BEZEL(A-HOLE)	VALHALLA	2724-205	4				
18		4-10618	BATTERY SPACER	VALHALLA	2734-206	1				
19		5-10266	STRIP RUBBER ADHESIVE	ACCURATE RUBBER	1/2x 3/16 - NEOPRENE	40*				ECR# 940
20		4-10614	REF. SELECTOR COVER PLATE	VALHALLA	2734-202	1				
21		4-20052	TOROIDAL PWR. XFMR.	COTSWOOD	DI003 WITH HARDWARE	1				
22		4-10318	TOP AND BOTTOM COVER	VALHALLA	2724-203	1				
23										

NOTES: SHT. 1+2 ARE THE ASSY. DWG.



PARTS LIST

DISPLAY BOARD ASSY.

MODEL 2734 A

DWG NO 2734-605

REV A

#	REF DES	VALHALLA PART NO	DESCRIPTION	CODE IDENT	MFG PART NO	QTY.			REMARKS
						I	N	N	
1									
2		4-30161	2734 A DISPLAY Bd.		2734-705	1			
3									
4									
5	DS1, 3, 5	5-01013	LED, GREEN, PANEL MOUNT	H.P.	5082-4955	3			
6	DS2, 4, 6	5-01028	LED, RED, PANEL MOUNT	H.P.	HLMP 3301	3			
7									
8									
9	PL1	5-10526	CONN. 20PIN, W/LOCK	R-Nug.	IDH-20K-S3-TG	1			
10									
11									
12	R1	1-01059	8.2 K, 5%, 1/4 W		RC07GF822J	1			
13	R2, 3, 4, 5, 6	1-01050	3.3 K, 5%, 1/4 W		RC07GF332J	5			
14									
15		5-10599	SPACER, 1/4 DIA, 1/8 LG, SWAGE #4	USECO	AI571-B-1/8-16	4			
16									
17									
18									
19									
20									

NOTES: SHT 1 OF 2 IS THE ASSY. DWG.



PARTS LIST

POWER SUPPLY BD.

MODEL

2734 A

DWG NO
2734-604

REV
B

#	REF DES	VALHALLA PART NO	DESCRIPTION	CODE IDENT	MFG PART NO	QTY.		REMARKS
						I	N	
24								
25	RV1	1-50022	1KΩ (END ADJUST)		B9PR1K	1		
26								
27								
28	TR1,2,3,4	3-10013	NPN TRANSISTER(TO92)		2N4401	4		
29								
30								
31	PL1	5-10526	CONN. 20 PIN, W/ LOCK			1		
32	PL2	5-10527	CONN. 34 PIN, W/ LOCK			1		
33								
34								
35		5-10582	CABLE TIE, 8.0" LG. x .10" WIDE	PANDUIT	PLT2M	1		
36		5-10592	SPACER, 1/4 DIA, 3/8 LG. ⁶ / ₃₂ DIA. ⁶ / ₃₂ LG. ⁶ / ₃₂ DIA.	USECO	A1570-B-3/8-16	6		
37								
38								
39								
40								
41								
42								
43								
44								
45								
46								

NOTES:



PARTS LIST

POWER SUPPLY BD.

MODEL

2734 A

DWG NO

2734-604

REV

B

#	REF DES	VALHALLA PART NO	DESCRIPTION	CODE IDENT	MFG PART NO	QTY.		REMARKS
						I	N	
1								
2		4-30160	POWER SUPPLY P.C.B.		2734 -704	1		ECR 912
3								
4								
5	C1	2-40038	2200 μ f, 80V, ALUM.			1		
6	C2,3,5	2-40026	10 μ f, 50V, ALUM. RAD.			3		
7	C4	2-60002	0.1 μ f, 250V MYLAR			1		
8								
9								
10	D1,3	3-20027	BRIDGE, 1A, 100V		3N247	2		
11	D2,4,5,6	3-20002	DIODE, RECTIFIER, 1A		1N4001	4		
12								
13								
14	R4,10	1-30007	470 Ω , 5%, 1W		RC32GF471J	2		
15	R5	1-01041	1K, 5%, 1/4W		RC07GF102J	1		
16	R6	1-01061	10K, 5%, 1/4W		RC07GF103J	1		
17	R7,8,9	1-01085	200K, 5%, 1/4W		RC07GF204J	3		
18	R1	1-01028	270 Ω , 5%, 1/4W		RC07GF271J	1		
19	R2	1-01055	5.6K, 5%, 1/4W		RC07GF562J	1		
20	R3	1-01007	10 Ω , 5%, 1/4W		RC07GF100J	1		
21								
22	XIC1, XIC2	5-10315	SOCKET T03	SMITH	6243	2		
23								

NOTES: SHI. 1 OF 3 IS THE ASSY. DWG.



PARTS LIST

REAR PANEL ASSY.

MODEL 2734A

DWG NO 2734-402

REV B

#	REF DES	VALHALLA PART NO	DESCRIPTION	CODE IDENT	MFG PART NO	QTY.			REMARKS
						I	N	N	
1									
2			POWER SUPPLY ASSY.		2734-604	1			
3									
4		4-10619	REAR PANEL	VALHALLA	2734-207	1			
5		5-04019	1AMP FUSE	LITTLEFUSE	312-001	1			EC2R939
6		5-10590	PWR CONN, FS HLD, SW	SCHAFFNER	FN-313-6-05-11	1			
7		4-10617	HEAT SINK	VALHALLA	2734-205	1			
8		5-03098	TOGGLE SWITCH, LATCHING	C&K	7201-K-ZGI	1			
9		5-10232	WASHER INSULATOR, T03	BURQUIST	7403-09FR-06	2			
10		5-10545	I.C. COVERS	THERMALLOY	8909NB	2			
11			RADIO HEX NUT		4-40	2			
12			PHIL, PAN, S.S.		6-32 x 3/8	4			
13			PHIL, PAN, S.S.		6-32 x 9/16	4			EC2R939
14			RADIO HEX NUT		6-32	6			
15			INTERNAL STAR WASH.		#6	9			
16			SPLIT LOCK WASH.		#6	4			
17			SPLIT LOCK WASH.		#4	2			
18	IC1	3-30356	REG., +ADJ., 1.5A, T03		LM317KC	1			
19	IC2	3-30370	REG., +B, 1.5A, T03		7818KC	1			
20		5-10018	FUSE HOLDER, PANEL MOUNT	LITTLEFUSE	345061	1			
21		5-10003	BINDING POST, BLACK	SUPERIOR	BP21BC	1			
22		5-10086	SOLDER LUG #6 INT. STAR			1			
23		5-10001	BINDING POST, RED	SUPERIOR	BP21RC	1			

NOTES: SHT. 1 IS THE ASSEMBLY DWG.



PARTS LIST

POWER SUPPLY BD.

MODEL

2734 A

DWG NO

2734-604

REV

B

#	REF DES	VALHALLA PART NO	DESCRIPTION	CODE IDENT	MFG PART NO	QTY.		REMARKS
						I	N	
1								
2		4-30160	POWER SUPPLY P.C.B.		2734 -704	1		ECR 912
3								
4								
5	C1	2-40038	2200 μ f, 80V, ALUM.			1		
6	C2,3,5	2-40026	10 μ f, 50V, ALUM. RAD.			3		
7	C4	2-60002	0.1 μ f, 250V MYLAR			1		
8								
9								
10	D1,3	3-20027	BRIDGE, 1A, 100V		3N247	2		
11	D2,4,5,6	3-20002	DIODE, RECTIFIER, 1A		1N4001	4		
12								
13								
14	R4,10	1-30007	470 Ω , 5%, 1W		RC32GF471J	2		
15	R5	1-01041	1K, 5%, 1/4W		RC07GF102J	1		
16	R6	1-01061	10K, 5%, 1/4W		RC07GF103J	1		
17	R7,8,9	1-01085	200K, 5%, 1/4W		RC07GF204J	3		
18	R1	1-01028	270 Ω , 5%, 1/4W		RC07GF271J	1		
19	R2	1-01055	5.6K, 5%, 1/4W		RC07GF562J	1		
20	R3	1-01007	10 Ω , 5%, 1/4W		RC07GF100J	1		
21								
22	XIC1, XIC2	5-10315	SOCKET T03	SMITH	6243	2		
23								

NOTES: SHI. 1 OF 3 IS THE ASSY. DWG.



PARTS LIST

REAR PANEL ASSY.

MODEL 2734A

DWG NO 2734-402

REV B

#	REF DES	VALHALLA PART NO	DESCRIPTION	CODE IDENT	MFG PART NO	QTY.			REMARKS
						I	N	N	
1									
2			POWER SUPPLY ASSY.		2734-604	1			
3									
4		4-10619	REAR PANEL	VALHALLA	2734-207	1			
5		5-04019	1AMP FUSE	LITTLEFUSE	312-001	1			EC2R939
6		5-10590	PWR CONN, FS HLDR, SW	SCHAFFNER	FN-393-6-05-11	1			
7		4-10617	HEAT SINK	VALHALLA	2734-205	1			
8		5-03098	TOGGLE SWITCH, LATCHING	C & K	7201-K-ZGI	1			
9		5-10232	WASHER INSULATOR, T03	BURQUIST	7403-09FR-06	2			
10		5-10545	I.C. COVERS	THERMALLOY	8909NB	2			
11			RADIO HEX NUT		4-40	2			
12			PHIL, PAN, S.S.		6-32 x 3/8	4			
13			PHIL, PAN, S.S.		6-32 x 9/16	4			EC2R939
14			RADIO HEX NUT		6-32	6			
15			INTERNAL STAR WASH.		#6	9			
16			SPLIT LOCK WASH.		#6	4			
17			SPLIT LOCK WASH.		#4	2			
18	IC1	3-30356	REG., +ADJ., 1.5A, T03		LM317KC	1			
19	IC2	3-30370	REG., +B, 1.5A, T03		7818KC	1			
20		5-10018	FUSE HOLDER, PANEL MOUNT	LITTLEFUSE	345061	1			
21		5-10003	BINDING POST, BLACK	SUPERIOR	BP21BC	1			
22		5-10086	SOLDER LUG #6 INT. STAR			1			
23		5-10001	BINDING POST, RED	SUPERIOR	BP21RC	1			

NOTES: SHT. 1 IS THE ASSEMBLY DWG.

SECTION XV - PARTS LISTS

15.1 General

The parts lists of this section are reproductions of factory parts lists. The designations are those of the diagrams of Section XIV. When ordering replacement parts, provide the reference designator, manufacturer's part number, manufacturer's name and Valhalla Scientific part number. The manufacturer may be identified in the parts list by Federal stock number. A list of manufacturer's Federal Stock Codes is provided as an appendix to this manual for identification of manufacturers.