

Valhalla Scientific Inc.

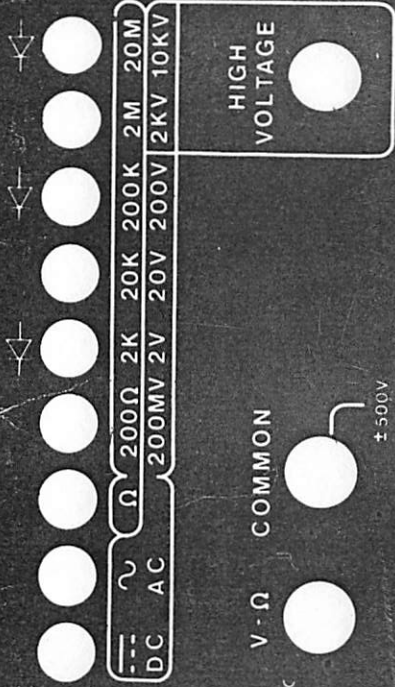

MODEL 4500 H.V. DIGITAL MULTIMETER

INSTRUCTION MANUAL

MODEL 4500

CERTIFICATION

Valhalla Scientific Inc. certifies that this instrument was thoroughly tested and inspected and found to meet its published specifications when it was shipped from the factory. Valhalla Scientific Inc. further certifies that its calibration measurements are traceable to the National Bureau of Standards to the extent allowed by NBS's calibration facility.

WARRANTY

Valhalla Scientific Inc. warrants this instrument against defects in materials and workmanship for one year from date of shipment. We will repair or replace the instrument during the warranty period provided it is returned to Valhalla Scientific Inc. No other warranty is expressed of implied. We are not liable for consequential damages. Permission must be obtained directly from factory for warranty repair returns. No liability will be accepted if returned without such permission. All instruments being returned to Valhalla Scientific Inc. must be shipped freight prepaid. Units repaired under warranty will be returned at no cost to the buyer, freight prepaid.

REPRESENTED BY
DUNCAN INSTRUMENTS LTD
122 Millwick Drive Unit 3
Weston, Ontario M9L 1Y6
Tel: (416) 742-4448

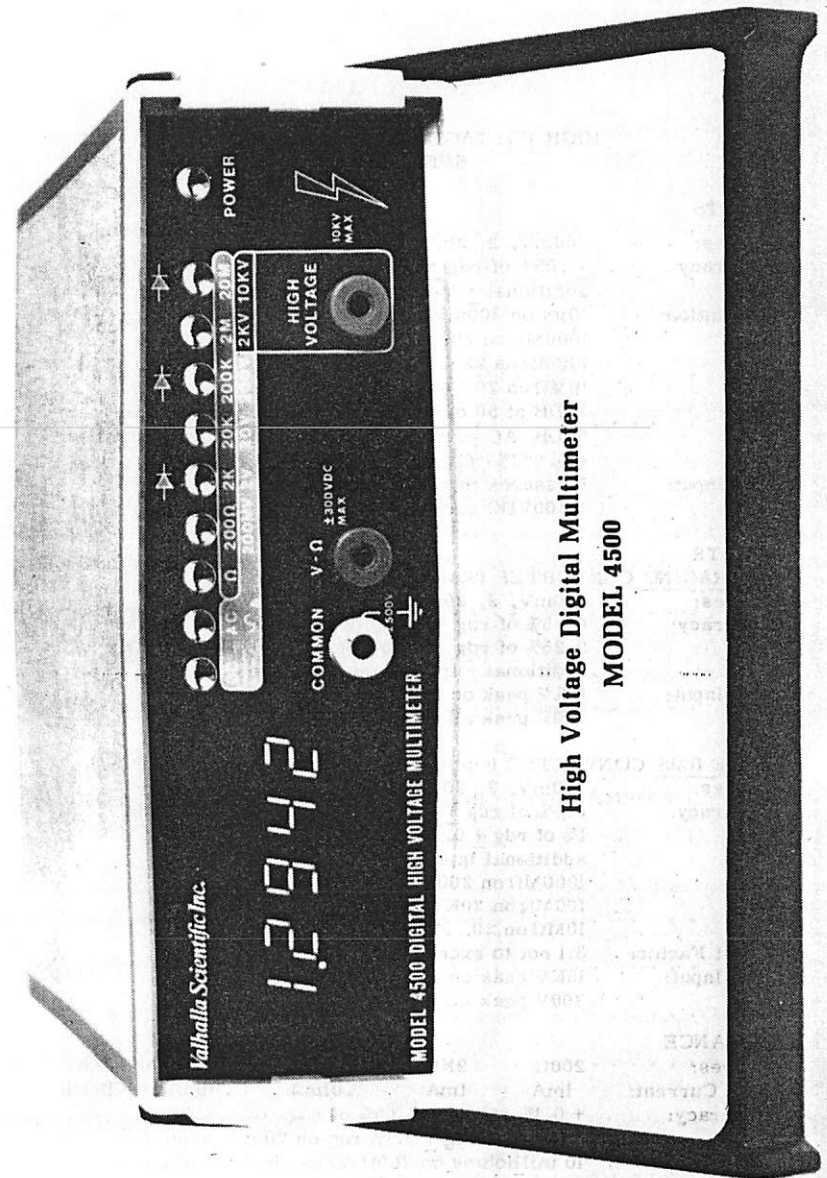

**MODEL 4500
HIGH VOLTAGE DIGITAL MULTIMETER
SPECIFICATIONS**

DC VOLTS

Ranges: 200mV, 2, 20, 200V, 2KV, 10KV
Accuracy: + .05% of rdg + .025% of rng
 additional + 1ppm/v on KV ranges
Resolution: 10µv on 200mV range, 0.005% rng
Zin: 1000MΩ on 200mV and 2V
 100MΩ on 2KV and 10KV
 10MΩ on 20V and 200V
NMR: 50DB at 50 or 60 Hz
CMR: 60DB AC powered, near infinity battery powered
TC: + 0.002%/°C
Max Input: Measures to +15KVDC max
 + 300VDC max on lower ranges

AC VOLTS

AVERAGING CONVERTER (Standard)

Ranges: 200mV, 2, 20, 200V, 2KV, 10KV
Accuracy: 0.25% of rdg + 0.25% of rng, 50Hz to 20KHz
 0.25% of rdg + 0.75% of rng, 20KHz to 50KHz
 additional + 1ppm/v on KV ranges
Max Input: 15KV peak on 2KV, 10KV
 300V peak all other ranges

TRUE RMS CONVERTER (Optional) (From 5% of range to F.S.)

Ranges: 200mV, 2, 20, 200V, 2KV, 10KV
Accuracy: 0.5% of rdg + 0.25% of rng, 50 Hz to 20KHz
 1% of rdg + 0.5% of rng, 20KHz to 50KHz
 additional 1ppm/V on KV ranges
Zin: 1000MΩ on 200mV and 2V
 100MΩ on 20KV and 10KV
 10MΩ on 20, 200V
Crest Factor: 3:1 not to exceed 150% of range
Max Input: 15KV peak on 2 KV and 10KV
 300V peak all other ranges

RESISTANCE

Ranges:	200Ω	2KΩ	20KΩ	200KΩ	2MΩ	20MΩ
Test Current:	1mA	1mA	.01mA	.01mA	100na	100na
Accuracy:	+ 0.1% of rdg + 0.05% of rng thru 2MΩ					
	+ 0.5% of rdg + 0.1% rng on 20MΩ range					
Resolution:	10 milliohms on 200Ω range, 0.005% of rng					
Max Input:	+250VDC or Peak AC					

TABLE OF CONTENTS

Page No.

GENERAL INFORMATION

1-1	Description	1-1
1-3	Accessories	1-1
1-5	Rechargeable Battery - Option 45B	1-1
1-7	True RMS/AC Converter - Option TRMS	1-1
1-9	Input Cable - Option C	1-1
1-11	High Voltage Test Probe - Option HVL	1-1
1-13	High Voltage Probe - Option HV-2	1-1
1-15	Temperature Probe - Option TEMP	1-2
1-17	1-2-4-8 Data Outputs - Option BCD	1-2
1-19	Multi-Range Current Shunt - Option M1	1-2
1-21	20-Amp Current Shunt - Option I	1-2
1-23	19-inch Rackmount Adaptor - Option 45R	1-2
1-25	True RMS & Averaging AC Converters - Option RMS-AVG	1-2

INSTALLATION

2-1	Introduction	2-1
2-3	Initial Inspection	2-1
2-6	Power Requirements	2-1
2-8	Installation	2-1

OPERATING INSTRUCTIONS

3-1	Introduction	3-1
3-3	Front Panel	3-1

OPERATING INSTRUCTIONS (Continued)

3-7	DC Voltage Measurements	3-1
3-15	AC Voltage Measurements	3-2
3-24	Resistance Measurements	3-3

THEORY OF OPERATION

4-1	Introduction	4-1
4-4	Functional Description	4-1
4-6	A/D Converter	4-1
4-27	AC/DC Converter	4-5
4-35	Ohms/DC Converter	4-6
4-40	Electrical Outputs	4-6

MAINTENANCE

5-1	Introduction	5-1
5-3	Required Test Equipment	5-1
5-5	Calibration Procedure	5-1
5-7	DC Calibration	5-1
5-8	Ohms Calibration	5-2
5-10	AC Calibration	5-2
5-11	Averaging AC Converter	5-2
5-12	Option TRMS Converter	5-2
5-14	Troubleshooting	5-2
5-18	Power Supplies	5-3

SECTION I

GENERAL INFORMATION

1-1 DESCRIPTION

1-2 The Valhalla Scientific Model 4500 is a 4-1/2 digit multimeter which provides three measurement functions: DC Voltage, AC Voltage and Resistance. It is especially useful for servicing computer terminals, TV monitors and other types of CRT display equipment, since it includes a high-voltage input that permits voltage measurements to $\pm 15KV$ DC and $10KV$ AC. It incorporates overload protection on all input ranges and functions when operated within specified limits. Although it normally operates from 115/230 VAC, an option (45B) permits operation from an internal battery supply which is rechargeable.

1-3 ACCESSORIES

1-4 The Valhalla Scientific Model 4500 is shipped with an instruction manual, a power cord and any options specified.

1-5 RECHARGEABLE BATTERY - OPTION 45B

1-6 This option consists of a 6-volt battery and a DC/DC converter. It permits up to six hours of continuous operation without recharging. The battery is on charge whenever the AC line cord is connected to the line, whether the power switch is ON or OFF.

1-7 TRUE RMS/AC CONVERTER

1-8 This option permits accurate measurements of AC voltages, whether sinusoidal or non-sinusoidal.

1-9 INPUT CABLE - OPTION C

1-10 This option is a shielded two-conductor cable which mates with the Model 4500 V- Ω input jacks and terminates in alligator clips.

1-11 HIGH VOLTAGE TEST PROBE - OPTION HVL

1-12 This option (or equivalent) is required for measurements on the 2KV and 10KV ranges. It consists of a special high-voltage cable and probe with an insulation rating compatible with the voltage rating of the instrument.

1-13 HIGH VOLTAGE PROBE - OPTION HV-2

1-14 This probe has a built-in attenuator that permits measurements to $\pm 40KVDC$ or 28KV AC RMS.

1-15 TEMPERATURE PROBE - OPTION TEMP

1-16 This option contains a temperature sensor and circuitry to provide a proportional input to the Model 4500 (100.00MV = 100.00°C).

1-17 1-2-4-8 DATA OUTPUTS - OPTION BCD

1-18 This option provides data outputs for driving a digital printer or a comparator such as the Valhalla Scientific Model 1248 Hi-Lo, Go No-Go, Dual Limit Comparator.

1-19 MULTI-RANGE CURRENT SHUNT - OPTION MI

1-20 This option provides six current ranges from 200 μ A to 20A. It converts the Model 4500 to a direct-reading digital ammeter.

1-21 20AMP CURRENT SHUNT - OPTION I

1-22 This option permits single-range current readings from 00.000 to 19.999 amperes.

1-23 19-INCH RACKMOUNT ADAPTOR - OPTION 45R

1-24 This option accepts the Model 4500 and adapts it for mounting in a 19-inch equipment rack. (3.5 H x 19 W x 10 D)

1-25 TRMS-AVG/AC CONVERTERS

1-26 This option allows operator to choose either True RMS or Averaging AC Converter via a rear panel selector switch.

SECTION II

INSTALLATION

2-1 INTRODUCTION

2-2 This section describes initial inspection and installation of the Model 4500 Digital Multimeter.

2-3 INITIAL INSPECTION

2-4 Inspect the shipping container for signs of damage before accepting the shipment. Notify the carrier immediately if any damage is noted, either before or after unpacking the instrument.

2-5 Unpack the instrument. Retain all packing material until you have thoroughly inspected the instrument for possible shipping damage.

2-6 POWER REQUIREMENTS

2-7 The Model 4500 Digital Multimeter operates from 115/230 volt 50-60 Hz power. If Option 45B is included it will also operate from an internal 6-volt battery. In battery mode, the load is absorbed by the AC line when connected to AC power and the Power switch is ON. The battery charges any time the AC line is connected, whether the Power switch is ON or OFF.

2-8 INSTALLATION

2-9 The Model 4500 dissipates little power and generates negligible heat. It may be used anywhere that the environment meets its specifications.

SECTION III

OPERATING INSTRUCTIONS

3-1 INTRODUCTION

3-2 This section provides complete operating instructions for the Model 4500. It also includes functional descriptions of the front-panel controls.

3-3 FRONT PANEL

3-4 The Power switch is an ON-OFF pushbutton located at the extreme right-hand side of the panel.

3-5 The Function switch comprises three interlocking pushbuttons located at the panel left-center. Volts DC, Volts AC, or K Ohms is selected by pushing the corresponding button.

3-6 The Range switch comprises six interlocking pushbuttons located at panel right-center. The desired range is selected by pushing the corresponding button.

3-7 DC VOLTAGE MEASUREMENTS

3-8 Low-voltage measurements are made via the V- Ω and Common jacks and are limited to 200 volts; voltages exceeding 200 are measured via the High Voltage and Common jacks and are limited to +15KVDC or 10KV AC RMS. DC voltages which may exceed 200 should be measured on the 2 KV range; if the actual voltage is less, the measurement may be repeated on the 200V range for maximum resolution.

3-9 HIGH VOLTAGE MEASUREMENTS

WARNING

Always use a high voltage probe with proper insulation. Avoid contact with either the Model 4500 or the high voltage source. Never touch any part of either with both hands at once. Contact with high voltage may cause injury or death.

3-10 Measure voltages expected to exceed 200 volts, via the High Voltage jack. Always use the Valhalla Scientific Option HVL (or equivalent). If the input exceeds +15KVDC, use the Valhalla Scientific Option HV-2 40KV Probe and

3-10 (Continued)
measure it via the V- Ω jack and common.

CAUTION

The maximum safe input at the Model 4500 High Voltage jack is ± 15 KV, DC or peak AC.

3-11 Always perform the following steps in exact sequence.

1. Disconnect the line power cord from the 4500, if battery operated.
2. Disconnect the line power cord from the high voltage source.
3. Set the Model 4500 Function to DC.
4. Set the Model 4500 Range to 10 KV.
5. Connect the HVL Test Probe to the Model 4500 High Voltage jack and the Common jack.
6. Connect the probe clip to high voltage common.
7. Connect the high voltage source to the AC line and turn the power on.

WARNING

If the test clip should pull loose after power is applied to the high voltage source do not touch it before disconnecting the line cord.

8. Allow time for the high voltage source to reach full output, then touch the HVL probe tip to the high voltage terminal. If the reading is less than 2 KV remove the probe, select the 2 KV range and repeat the measurement for maximum resolution.

3-12 LOW VOLTAGE MEASUREMENTS

3-13 Use the V- Ω and common jacks to measure 200 volts or less. Use Option C Shielded Input Cable (or equivalent) for all low voltage and resistance measurements to prevent errors due to noise pickup.

3-14 The maximum safe input on all low voltage ranges is 300 volts. To make low voltage measurements:

1. Select the DC Function and the 200V range.
2. Connect the input cable to the unknown voltage source.
3. If the reading is less than 20 volts select the range that will give greatest resolution.

8-15 AC VOLTAGE MEASUREMENTS

3-16 Inputs less than 200 VAC rms are measured via the V- Ω and Common jacks; maximum safe input is 300 volts peak.

3-17 High voltages are measured via the High Voltage and Common jacks and are limited to 10 KV rms. Maximum safe input is a volt-Hz product not to exceed 10^6 , or 15 KV peak, whichever is less. Measure voltages which may exceed 200 volts rms at the High Voltage jack. If the input is less than 200 volts repeat the measurement on the 200V range for greatest resolution.

3-18 HIGH VOLTAGE MEASUREMENTS

WARNING

Always use a high voltage probe (Valhalla HVL or equal). Avoid contact with either the Model 4500 or the high voltage source. Never touch any part of either with both hands at once. Contact with high voltage may cause injury or death.

3-19 Perform the following steps in exact sequence to measure high voltage.

1. Disconnect the line power cord from the 4500, if battery operated.
2. Disconnect the high voltage source from the AC power line.
3. Set the Model 4500 Function switch to AC and the Range to 10 KV.
4. Connect the HVL test probe to the Model 4500 High Voltage and Common jacks.
5. Connect the HVL test probe clip to the common side of the high voltage source.

WARNING

If the test probe clip should pull loose after power is applied to the high voltage source do not touch it before disconnecting the line cord of the source.

6. Connect the high voltage source to the AC line and allow time for it to reach full output.
7. Touch the HVL probe tip to the high voltage terminal and note the reading. If it is less than 2KV remove the high voltage probe tip from the high voltage terminal, select the 2 KV range and repeat the measurement for maximum resolution.

3-21 LOW VOLTAGE MEASUREMENTS

3-22 Inputs of less than 200 volts rms are measured via the V- Ω and Common jacks. Use the Valhalla Scientific Shielded Input Cable (Option C). Maximum safe input voltage 300 volts peak.

3-23 To measure low voltages:

1. Select the AC Function and the 200V Range.
2. Connect the input cable to the unknown voltage.
3. Observe the reading and select the range that will yield greatest resolution.

3-24 RESISTANCE MEASUREMENTS

3-25 The maximum safe input voltage is 250 VDC or peak AC. To measure resistance:

1. Select the Ω Function and the 20M Range.
2. Connect the unknown resistance between the V- Ω and common jacks via the shielded input cable (Option C) to prevent inaccurate readings due to noise pickup.
3. Observe the reading and select the range that will yield greatest resolution.

NOTE

An over-range condition is indicated by blanking all but the most significant digit. Up range until a valid indication is obtained.

SECTION IV
THEORY OF OPERATION

4-1 INTRODUCTION

4-2 The Valhalla Scientific Model 4500 Digital Multimeter is basically an A/D Converter that measures and displays DC voltages. It also includes AC/DC and OHMS/DC Converters which produce DC voltage outputs proportional to their inputs. These outputs are measured and displayed by the A/D Converter.

4-3 Model 4500 circuitry is totally solid state, using CMOS IC's extensively to minimize power consumption.

4-4 FUNCTIONAL DESCRIPTION

4-5 The following functional description is based on Figures 4-1, 4-2 and the Model 4500 schematic, Drawing Number 4500-070.

4-6 A/D CONVERTER

4-7 The Model 4500 A/D Converter incorporates a three-step integrator which provides automatic zero correction, high impedance differential inputs and automatic polarity.

4-8 The major components of the A/D Converter are a precision timer IC11, an analog processor IC12, a digital processor IC13 and a precision-voltage reference supply IC14. The analog processor contains the zero-correction circuitry, an integrator, a zero-crossing detector and the switches required to implement the integration process.

4-9 The digital processor contains an oscillator, a counter, a buffer register, an output decoder and circuitry to control the analog processor.

4-10 The three-step integration process consists of (1) sensing and storing in C14 any error voltage present in the analog circuits due to offset, noise or drift; (2) charging integrator capacitor C17 from the unknown input voltage for a fixed time; and (3) applying the reference voltage to C17 in the opposite polarity to the unknown input voltage for whatever time it takes to discharge C17 back to zero.

4-11 The greater the charge on C17 the longer it will take to discharge it to zero, and the time is measured by counting the output of the oscillator in the digital processor. The oscillator frequency and the maximum integration time are chosen to produce a count exactly equal to full-range input. If the unknown

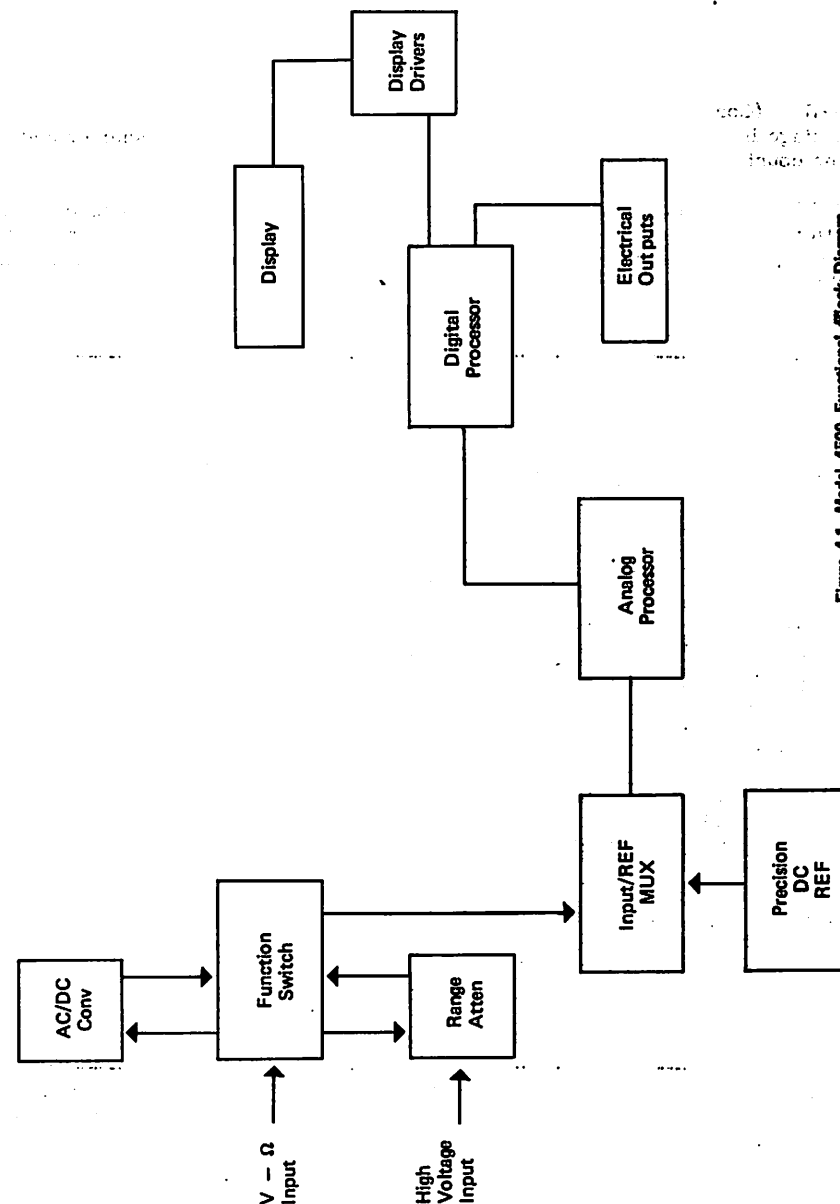

Figure 4-1. Model 4500 Functional Block Diagram.

4-11 (Continued)

voltage is less than full-range input the integration time will be shorter and the count will be proportionately less.

4-12 The count is stored in the buffer register of the digital processor, and after the reference has been integrated it is shifted into the display, where it remains until the next reference integration has been completed. At that time the display is updated to again indicate the unknown input voltage.

4-13 INTEGRATOR OPERATION AND CONTROL

4-14 Time periods A and B of Figure 4-2 show two complete integration cycles; the former is for a positive input, the latter for a negative input. During the first step of Period A both IC12-8 and -9 are set LOW by the digital processor, IC13. Analog inputs IC12-1 and -2 are internally disconnected from the integrator, and its input is grounded. Zero Sense capacitor C14 is charging to the value of any error voltage present in the analog circuits, and Reference capacitor C20 is charging from precision reference supply IC14 via IC12-4.

4-15 After a fixed time IC13 forces both IC12-8 and -9 HIGH and the second integration step begins. C14 and IC12-1 and -2 are connected to the integrator. The C14 charge corrects for offset while C17 charges toward the value of the unknown input voltage at a rate proportional to its amplitude. During this time the Zero-Crossing Detector output at IC12-10 goes HIGH and sets the polarity bit in the digital processor.

4-16 At the end of the fixed integration period IC13 forces IC12-8 LOW and the reference integration begins. C20 is connected to the integrator with its charge opposing the polarity of the charge on C17. The counter in IC13 is simultaneously gated ON and as C17 discharges back toward zero it counts the oscillator output in BGD format and stores it in the Buffer Register.

4-17 When the charge on C17 is reduced to zero IC12-10 drops out of its HIGH state, telling IC13 to gate the counter OFF. IC13 then forces IC12-9 LOW, returning the analog processor to the Zero Sense state. The accumulated count and the polarity are then displayed on the LED indicators until the next measurement is completed, when the display is updated.

4-18 Period B of Figure 4-2 shows timing for a negative voltage measurement. With IC12-8 and -9 LOW, C14 and C20 are charged. When IC13 forces IC12-8 and -9 HIGH the negative input is applied to the integrator input, charging C17 negative until IC13 forces IC12-9 LOW. During this time IC12-10 sets the polarity

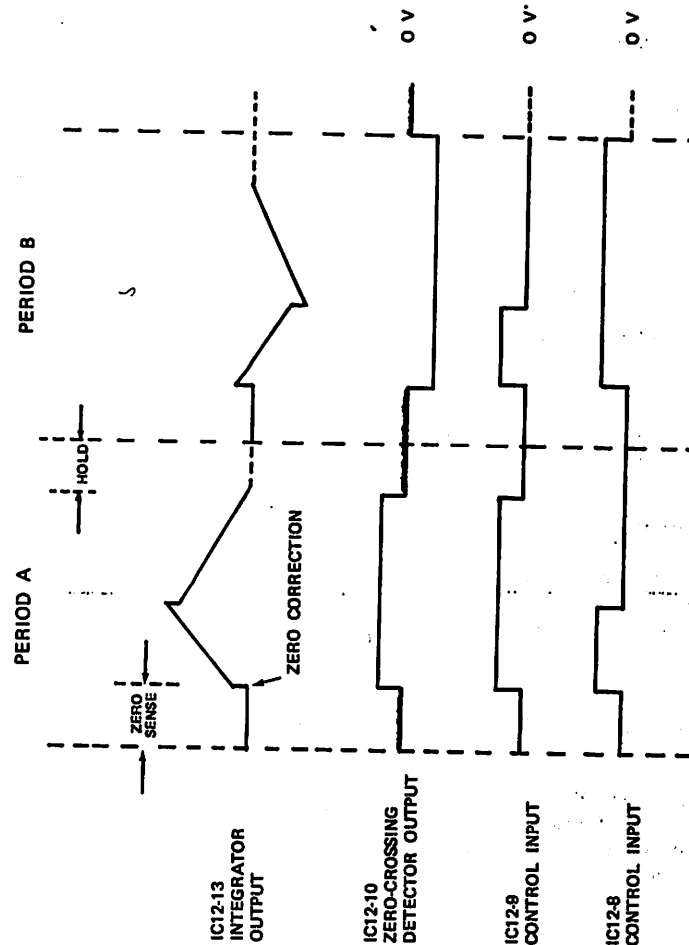

Figure 4-2, Model 4500
AID Converter Timing Diagram
for (A) positive input and (B) negative input.

4-18 (Continued)

bit LOW, C20 discharges C17 back toward zero, and the oscillator output is counted. When C17 is discharged IC12-10 leaves the LOW state, the counter is gated OFF and IC12-8 is set LOW, returning IC12 to the Zero Sense state. The new count and polarity are now displayed.

4-19 LED DISPLAY

4-20 The display is produced by a scanning process, with each LED indicator being switched on and off at a 1 KHz rate. While no two indicators are turned on simultaneously, the 1 KHz switching rate makes them all appear to be on continuously.

4-21 The 1 KHz pulse train used to switch the indicators is derived by dividing the 200 KHz oscillator output, set by the precision timer input applied to IC13-17. The switching outputs are applied to indicator drivers Q2-Q6 via IC13-2 to -6, as shown in Figure 4-3.

4-22 The BCD count corresponding to the least significant digit is shifted out of the buffer register, decoded into seven-segment format, and appears at IC13-7 to -14 at the time IC13-2 enables Q4, causing the LED indicator to display the count. This shifting and decoding process is repeated for the 10^2 , 10^3 , 10^4 and finally the most significant digit as Q3, Q2, Q5 and Q6 are sequentially enabled. The result is a display that appears continuous to the human eye.

4-23 INPUT ATTENUATOR

4-24 When either the 200MV or 2V range is selected the unknown input voltage is not attenuated. Instead, it is applied via the Function and Range switches directly to the A/D Converter input IC12-1 and -2. If the 200MV range is selected, however, it applies +8 volts to IC7-12 and -13. This sets the A/D Converter gain to maximum and reduces the reference voltage by a factor of 10. (Since IC7-1 and -2 are effectively open and IC7-3 and -4 are effectively closed the reference voltage is applied to IC12-4 from the arm of R19.)

4-25 When the 2V range is selected the +8 volts is removed from IC7-12 and -13 and applied to IC7-5 instead. Consequently the A/D Converter gain is reduced by a factor of 10 and the reference voltage is increased by the same factor, since it is now to IC12-4 from the arm of R21 instead of R19.

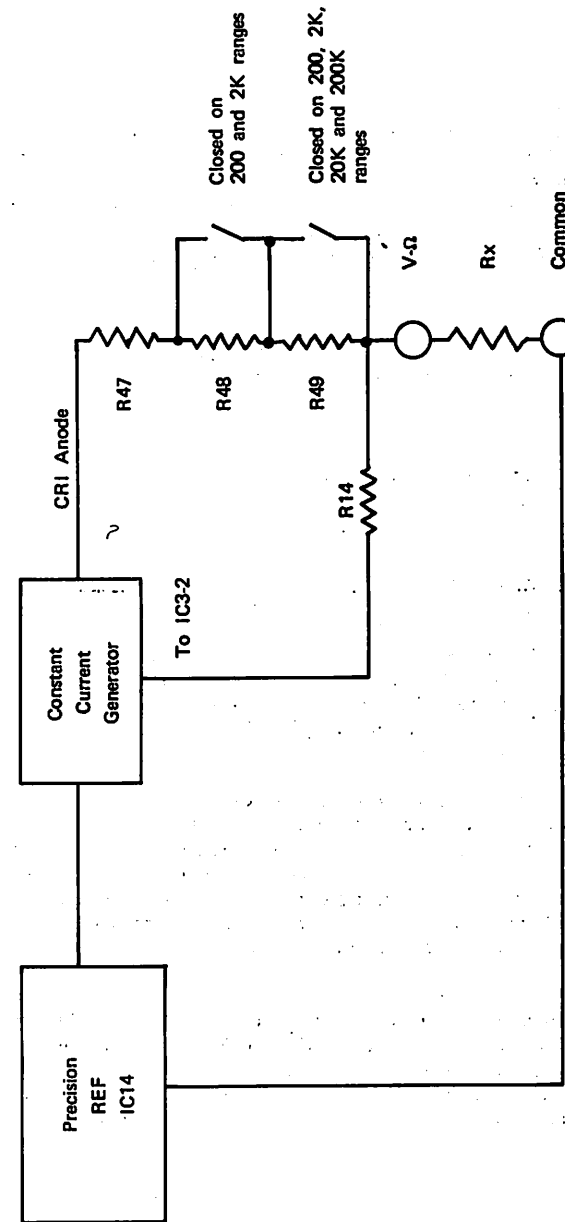

Figure 4-3. Ohms/DC Converter Block Diagram. Range selectors set attenuator ratio and output of constant current generator (see description in Subsection 4-35).

4-26 When either the 20V or 200V range is selected the input voltage is applied to a divider consisting of R47, 48 and 49. The output of the divider is the junction of R47 and R49, and the unknown input is attenuated by a factor of 100:1. On the 20V range IC7 sets the A/D Converter high; on the 200V range it is reduced as it was on the 2V range. On the 2KV or 100KV range the attenuator comprises R47-52, providing 10,000:1 attenuation. The A/D Converter gain is again selected by IC7, as it was on the lower range pairs.

4-27 AC/DC CONVERTER

4-28 The Model 4500 is available with the standard "averaging" AC Converter, a true RMS AC Converter (Option TRMS) or both. Consequently the Model 4500 can be used to accurately measure either sinusoidal or non-sinusoidal AC voltages.

4-29 The standard AC Converter consists of IC8, IC9, IC10, CR8 and CR9 and associated components.

The AC input is coupled from the attenuator through C18 to IC8-3. On the 200MV, 20V and 2KV ranges R23 is grounded via IC7-8 and -9 for maximum gain; on all other ranges R23 is ungrounded and IC8 gain is reduced by 10:1.

4-30 The output at IC8-6 is coupled through C9 and R32 to IC9. CR8 and CR9 provide feedback around IC9 via R33 and R34, and the rectified output is coupled from CR9 and filtered by R35 and C10. The DC output at IC10-6 is proportional to the ACrms input (for sinusoidal voltages only) and is coupled via the AC Function switch to the A/D Converter input at IC12-1.

4-31 The Option TRMS AC Converter comprises IC4 and associated components; its input at IC4-1 is coupled from IC8-6 via C9, R7 (gain trimmer) and C6. IC4 internal circuitry consists of a voltage-to-current converter, a squarer/divider, a current averager and a source follower that produces the output at IC4-6. C4 and C5 set the current averaging period and also determine the ripple level and settling time of the converter. C3 filters the current output at IC4-8 before it is applied to the output buffer at input terminal IC4-7. R69 is the zero offset adjustment.

4-32 The AC voltage input at IC4-1 is converted to a proportional AC current which is squared, averaged and divided to provide an RMS current output at IC4-8. This output drives the buffer input at IC4-7 to produce a DC voltage equivalent to the true RMS AC input. The voltage is coupled via the AC Function switch to the A/D Converter input IC12-1 and -2 for measurement.

4-33 INPUT ATTENUATOR

4-34 On the AC Function the range attenuator switching is identical to that on the DC Function (described in Sub-section 4-23) with one exception; on AC the DC reference voltage and A/D Converter gain are held constant for all ranges by IC7-12 and IC7-5 via the AC Function switch. The AC Converter gain, however, is alternately set high and low via the Range Selector switches.

4-35 OHMS/DC CONVERTER

4-36 The Ohms/DC Converter is a constant-current generator which is connected to the unknown resistance Rx. The voltage drop across Rx is proportional to its resistance, and Erx is measured by the A/D Converter and displayed as the value of Rx.

4-37 The constant-current generator consists of IC1, IC2, IC3, Q1, CR1 and associated components. Its input is derived from the precision reference IC14 via the arm of R19 and applied at IC1-3. The output at IC1-6 is applied to floating differential amplifier input IC2-3. IC2-6 drives IC3, which is the first section of the constant-current output stage. The output at IC2-6 is accurately controlled by feedback resistors R3 and R13. Network R5-C2 provides high-frequency stabilization.

4-38 The constant current originates at the anode of CR1. The amount of current through Rx is determined by the range selected. On the 200 or 2K range the feedback from the junction of R47 and Rx sets the current to 1 ma; selecting the 20K or 200K range connects R48 in series with R47 and reduces the current to 10 μ a. On the 2M or 20M range R47, R48 and R49 are connected in series and the current through Rx is reduced to 100 na.

4-39 When the 200, 20K or 2M range is selected +8 volts is applied to IC7-12 and -13 via the AC Function switch contacts. This sets the A/D Converter gain high and reduces the reference voltage applied at IC12-4. When the 2K, 200K or 10M range is selected the +8 volts is removed from IC7-1 and -13 and applied to IC7-5. The A/D Converter gain is reduced and the reference voltage is increased, each by a factor of 10.

4-40 ELECTRICAL OUTPUTS

4-41 The Model 4500 provides electrical outputs in BCD format that are directly compatible with the Valhalla Scientific Model 1248 Digital Comparator.

SECTION V
MAINTENANCE

4-41 (Continued)

These outputs are developed by decoding the 7-segment outputs of IC13 and applying them to the inputs of a seven segment to BCD connector.

4-42 The BCD outputs and the outputs from Q2-Q5 appear at an Amphenol 57-40500 connector at the rear of the Model 4500. Connections are shown in Figure 4-4. When the Model 4500 and the Model 1248 are interconnected the BCD outputs are connected in parallel to the 1's, 10's, 100's and 1000's decades of the Model 1248. The inputs from Q2-Q6 sequentially enable each decade, clocking the corresponding BCD data into the comparison circuits of the Model 1248.

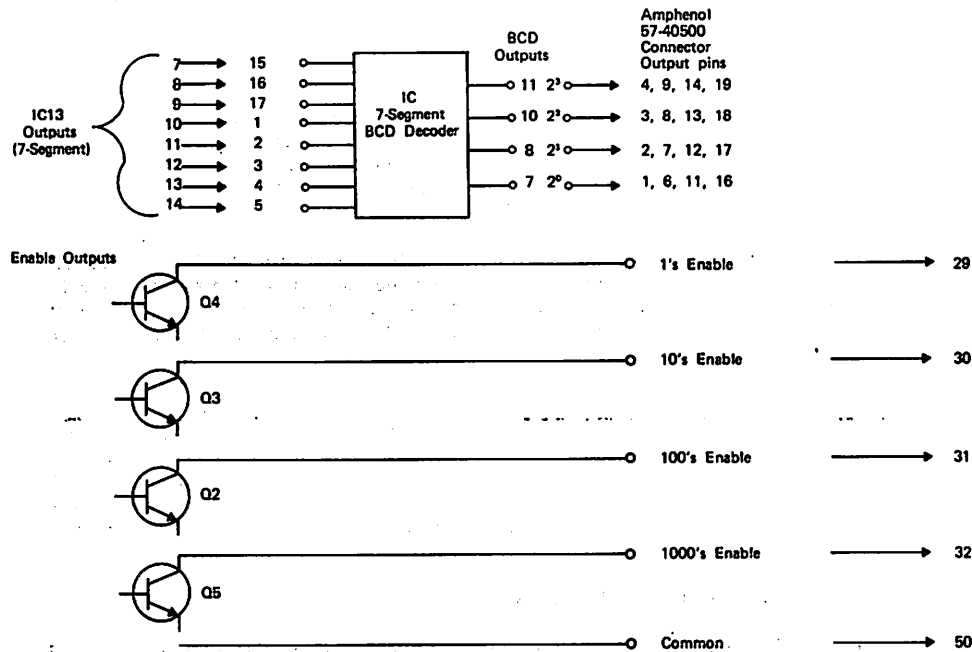

Figure 4-4. Electrical Output Connections of Model 4500

5-1 INTRODUCTION

5-2 This section contains maintenance information for the Valhalla Scientific Model 4500 Digital Multimeter. Included are a test equipment list and calibration procedures.

5-3 REQUIRED TEST EQUIPMENT

EQUIPMENT	PERFORMANCE SPECIFICATIONS
DC Voltage Standard	+0.003% accuracy, 0.1 to 200V; +0.01% accuracy, 200 to 1 KV.
AC Voltage Calibrator	+0.02% accuracy, 0.1 to 100Vrms at 1 KHz.
Precision Resistor	+0.005%, 1 K ohm.
Oscilloscope	50mVDC/CM sensitivity.
Frequency Counter	+0.01%, 10 Hz-1 MHz.

5-5 CALIBRATION PROCEDURE

5-6 The Model 4500 should be calibrated periodically to insure continuing accuracy; it should also be calibrated if an accuracy-determining component is repaired or replaced.

Turn on the instrument at least five minutes before beginning calibration.

5-7 DC CALIBRATION

1. Select DC Function and 200mV range.
2. Connect the counter to IC11-3 and adjust R53 for a 200KHz reading in the counter display. Remove the counter connections.
3. Short the Model 4500 V-Ω and Common jacks. Adjust R75 for 00.00 in the display.
4. Apply +100 mVDC between V-Ω and Common. Adjust R21 for 100.00 in the display.
5. Select DC Function and the 2V range. Apply +1 VDC between V-Ω and Common. Adjust R19 for 1.0000 in the display.
6. Select DC Function and the 2KV range. Apply 1 KV between the High Voltage and Common jacks. Adjust R51 for 1000.0 in the display. This completes DC calibration.

5-8 OHMS CALIBRATION

5-9 OHM CONVERTER

1. Select Ω Function and the 2K range.
2. Connect the 1K precision resistor from V- Ω to Common.
3. Adjust R10 for 1.0000 in the display.

5-10 AC CALIBRATION

NOTE

DC Calibration steps 1-6 must be performed to insure specified AC accuracy.

5-11 AVERAGING AC CONVERTER

1. Select the AC Function and the 200MV range. Short V- Ω and Common. Adjust R26 for 00.00 in the display.
2. Apply 100mVACrms at 1 KHz between V- Ω and Common. Adjust R23 for 100.00 in the display.
3. Select the 2V range. Apply 1 VACrms at 1 KHz between V- Ω and Common. Adjust R36 for 1.0000.

5-12 OPTION TRMS CONVERTER

1. Select the AC Function and the 2V range. Apply 100 mVACrms at 1 KHz between V- Ω and Common. Adjust R69 for .1000 in the display.
2. Increase the input voltage of (7) to 1 volt. Adjust R7 for 1.0000 in the display.
3. Reduce the input voltage to 100 mv and select the 200MV range. Adjust R23 for 100.00 in the display.

5-13 The following step is performed to complete calibration of both the Standard and TRMS converters.

1. Select the 200V range. Apply 100 VACrms at 10 KHz between V- Ω and Common. Adjust C16 for 100.00 in the display.

5-14 TROUBLESHOOTING

5-15 Apparent difficulties are sometimes merely misinterpretations of specifications. In other cases they may be caused by excessive input noise, either superimposed on the input signal or radiated to the input leads. In any case the user should make every effort to assure himself that the instrument is truly malfunctioning before attempting repairs.

5-16 Frequently a digital multimeter malfunction will only be evident on a single range or function. At other times it will be apparent on every range and function. When an instrument is totally inoperative, examine the power supply. If it malfunctions on all functions check for problems in the common sections of the instrument; that is, the power supplies, the A/D Converter or the digital processor control circuitry.

5-17 Cycling the instrument through each of its functions and ranges while observing the display will often indicate exactly which section of the instrument is malfunctioning. Refer to the diagrams of Section IV, and the accompanying circuit descriptions, if unfamiliar with the operating principles of any part of the instrument. The clues obtained, combined with a working knowledge of the circuits should allow correction of any malfunction.

5-18 POWER SUPPLIES

5-19 The power transformer delivers AC to two DC supplies. One consists of CR6, CR7 and C13. It produces +5 volts.

5-20 The second supply consists of CR2-5 and C11-12. These components comprise a bridge rectifier which develops and filters +12 volts DC. IC5 and IC6 are regulators which reduce these voltages to a nominal +8 volts.

5-21 Option 45B consists of a rechargeable sealed battery supply and a DC/DC Converter, the latter comprising IC1, IC2, Q1, Q2, C1 and a transformer. When the Power switch is ON the battery is connected from the center tap of the transformer to the emitters of Q1 and Q2. IC1 and IC2, dual flip-flops, divide the 200 KHz output of IC11-3. The resulting 12.5 KHz pulses alternately switch Q1 and Q2 on and off. The resulting conduction of Q1 and Q2 produce AC pulses in the transformer primary. These pulses induce an AC voltage across the transformer secondary. This AC voltage is rectified by the bridge comprising CR1-CR4 and is filtered by C2 and C3. The +12 volt output is regulated by IC5 and IC6 to produce the +8-volt supply. The battery itself produces the +8 volts.

5-22 When the instrument line cord is plugged into an AC power source, Option 45B operates essentially in a no-load condition and the battery charges, even when the Power switch is OFF.

Valhalla Scientific Inc		PARTS LIST		
REF. DES.	V.S. P/N	DESCRIPTION	MFG.	MFG. P/N
C1	2-10009	CAP CERM .001 μ f	56289	5GADI0
C2	2-10004	CAP CERM .02 μ f	56289	5GAS20
*C3	2-30000	CAP TAN 4.7 μ f/10V	05397	T360B475M10AS
*C4	2-30008	CAP TAN 6.8 μ f/10V	05397	T360B685M010AS
*C5	2-20009	CAP MICA 470Pf	81349	CM05FD471J03
C7, 8, 9, 10	2-30001	CAP TAN 10 μ f/10V	05397	T360B106M025AS
C11, 12, 21	2-40001	CAP ELECT 250 μ f/25V	14655	BR250-25
C13	2-40004	CAP ELECT 2200 μ f/16V	56289	16T2200
C14, 20	2-80002	CAP MYLAR 1 μ f/50V	12406	Z5A105
C15, 24	2-60004	CAP PAPER .01 μ f	56289	418P10396K03
C16	2-70000	CAP VAR 12 Pf	73899	VC58G
C17	2-50000	CAP POLY .22 μ f	27556	PA2A224
C18, 22	2-10000	CAP CERM .005 μ f	56289	5GAD50
C19	2-20008	CAP MICA 240Pf	81349	CM05FD241J03
C23	2-60000	CAP PAPER .0047 μ f	56289	225P47291
C26, 31	2-20013	CAP MICA 100Pf	81349	CM05FD101J03
C27	2-60002	CAP PAPER .1/100V	56289	225P10491
C 28, 29, 30	2-10006	CAP CERM .01 μ f	56289	5GAS10
*C6	2-30007	CAP TAN 2.2 μ f/10V	05397	T360B225M10AS
C25	2-20015	CAP MICA 75Pf	81349	CM05FD750J03
CR1	3-20004	DIODE	07263	1N4004
CR2-7	3-20002	DIODE RECT	07263	1N4001
CR8,9	3-20000	DIODE	07263	1N914
DS1	5-01018	LED + DISPLAY	28480	5082-7756
DS2-5	5-01007	LED 0-9 DISPLAY	28480	5082-7750
IC1, 2, 3, 8, 9, 10	3-30090	IC OP-AMP	27014	LF356N
*IC4	3-30045	IC RMS TO DC CONV Analog Dev.	27014	AD536JD
IC6	3-30085	IC REG POS	27014	LM340T-8.0
IC5	3-30086	IC REG NEG	27014	LM320T-8.0
IC7	3-30023	IC QUAD SWITCH	86684	CD4066BF
IC11	3-30009	IC TIMER	27014	NE555V
IC12	3-30087	IC A/D CONV ANALOG	01295	TL500C
IC13	3-30088	IC A/D CONV DIGITAL	01295	TL502C
IC14	3-30064	IC REFERENCE	04713	MC1403
J1	5-10031	BANANA JACK WHT	05276	1581-WHT
J2	5-10032	BANANA JACK BLK	05276	1581-BLK
J3	5-10030	BANANA JACK RED	05276	1581-RED
Q1	3-10015	TRANSISTOR H. V.	04713	MJE3439
Q2-6	3-10010	TRANSISTOR PNP	04713	2N4402
MODEL: 4500	TITLE: DIGITAL H. V. MULTIMETER	SHT 1 OF 3		

Valhalla Scientific Inc		PARTS LIST		
REF. DES.	V.S. P/N	DESCRIPTION	MFG.	MFG. P/N
R29	1-10104	RES FXD 150K 1%	81349	RN60C1503F
R1, 33, 38, 45, 46, 70	1-01061	RES FXD 10K 1/4W 5%	81349	RC07GF103J
R2, 3, 12, 13	1-10006	RES FXD 100K 1% Matched	81349	RN60C1003F
R4, 5, 76	1-01045	RES FXD 2K 1/4W 5%	81349	RC07GF202J
R6	1-01073	RES FXD 47K 1/4W 5%	81349	RC07GF473J
*R7, 51	1-50004	RES VAR 500 Ω	71450	X201R50I
*R8	1-10085	RES FXD 249 Ω 1%	81349	RN60C2490F
*R9	1-01093	RES FXD 470K 1/4W 5%	81349	RC07GF474J
R23	1-50000	RES VAR 100 Ω	71450	X201R10I
R32, 34, 35	1-10008	RES FXD 10K 1%	81349	RN60C1002F
R14, 54, 27	1-01081	RES FXD 100K 1/4W 5%	81349	RC07GF104J
R15	1-01033	RES FXD 470 Ω 1/4W 5%	81349	RC07GF47LJ
R16, 28	1-01021	RES FXD 100K 1/4W 5%	81349	RC07GF101J
R30		FACTORY SELECT		
R19, 36	1-50002	RES VAR 1K	71450	X201R102
R20	1-10025	RES FXD 90.9K 1%	81349	RN60C9092F
R24	1-10105	RES FXD 887 Ω 1%	81349	RN60C8870F
R25	1-10017	RES FXD 9.09K 1%	81349	RN60C9091F
*R26, 53, 69, 10, 75	1-50005	RES VAR 50K	71450	X201R503
R31	1-01128	RES FXD 1000M 1/4W 5%	81349	RC07GF105J
R37	1-10054	RES FXD 22.1K 1%	81349	RN60C2212F
R39	1-10012	RES FXD 20K 1%	81349	RN60C2002F
R40	1-01041	RES FXD 1K 1/4W 5%	81349	RC07GF102J
R41	1-01060	RES FXD 9.1K 1/4W 5%	81349	RC07GF912J
R42	1-01068	RES FXD 27K 1/4W 5%	81349	RC07GF273J
R43	1-10015	RES FXD 243K 1%	81349	RN60C2433F
R44	1-10028	RES FXD 24.9K 1%	81349	RN60C2492F
R47	1-10090	RES FXD 1K .1%	Caddock	
R48	1-10090	RES FXD 99K .1%	Caddock	
R49	1-10090	RES FXD 9.9M .1%	Caddock	
R50	1-10093	RES FXD 100M 1%	Caddock	MC780
R52	1-10073	RES FXD 9.76K 1%	81349	RN60C9761F
R55-59	1-01053	RES FXD 4.7K 1/4W 5%	81349	RC07GF472J
R60-67, 68, 71	1-01026	RES FXD 220 Ω 1/4W 5%	81349	RC07GF221J
R73	1-01007	RES FXD 10 Ω 1/4W 5%	81349	RC07GF100J
R74	1-01104	RES FXD 2M 1/4W 5%	81349	RC07GF205J
R22	1-10099	RES FXD 10.2K 1%	81349	RN60C1022F
R21	1-50007	RES VAR 250 Ω	71450	X201R25I
S1	5-03026	PUSH BUTTONFUNCTION	71590	5-03026
*S2	5-03007	TOGGLE SWITCH	95146	MST-105D
T1	4-20019	POWER TRANSFORMER	53504	4500-010
MODEL: 4500	TITLE: DIGITAL H. V. MULTIMETER	SHT 2 OF 3		

Valhalla Scientific Inc

PARTS LIST

REF. DES.	V.S. P/N	DESCRIPTION	MFG.	MFG. P/N
1 ea	4-30043	P. C. BOARD MAIN	53504	4500-700D
1 ea	4-30045	P. C. BOARD DISPLAY	53504	4500-702A
1 ea	4-10130	CHASSIS	La France	CH-250 Beige
1 ea	5-10094	FUSE HOLDER	75915	155120
1 ea	4-10166	FRONT PANEL	53504	4500-200A
1 ea	4-10167	REAR PANEL	53504	4500-201B
1 ea	5-10063	POWER CONN	82389	EAC-301
1 ea	5-10007	TERMINAL		1300B
1 ea	4-10177	SHIELD	53504	4500-204
1 ea	5-10067	POWER CORD	70903	17250
2 ea		6-32 x 1/2 PAN HEAD SCREWS		
12 ea		#4 SELF TAPPING SCREWS		
2 ea		4-40 x 1/2 PAN HEAD		
2 ea		6-32 HEX NUTS		
2 ea		4-40 HEX NUTS		
2 ea		#6 INTERNAL STAR WASHERS		
2 ea		#4 INTERNAL STAR WASHERS		
1 ea		FUSE 1/4A		
* NOT IN STANDARD UNIT				
MODEL: 4500		TITLE: DIGITAL H. V. MULTIMETER		SHT 3 OF 3

OPTION "45B" FIELD RETROFIT INSTRUCTIONS

STEP NO. 1

Remove four screws from bottom of unit and carefully separate top and bottom lids. Both the front and rear panels should remain with top lid.

STEP NO. 2

Place top lid on work surface with P. C. board facing up.

STEP NO. 3

Dyke all small mold marks and one stand-off in order to allow flush fit of battery assembly in back right hand corner of the unit. Leave the three stand-offs which coincide with the holes on the battery assembly P. C. board.

STEP NO. 4

Place battery assembly P. C. board down in the right rear vacant area of the inverted lid. (Stand-offs should protrude thru the holes in P. C. board.)

STEP NO. 5

Solder wires from battery assembly to main board in a pt. to pt. manner. Be careful not to short batteries.

STEP NO. 6

Insert and solder in K-74 and 500Ω pot in R76. (Both are located on extreme left hand side of main PC Board.)

STEP NO. 7

Check to insure pot is centered.

STEP NO. 8

Drill out feed thru hole next to K74.

STEP NO. 9

Short pins 1 and 3 from power off-on switch as they appear here.

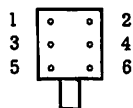

This may be accomplished by bending them together and soldering.

NOTE: Batteries will now charge in the power on or power off mode and last 6 hours on a full charge.

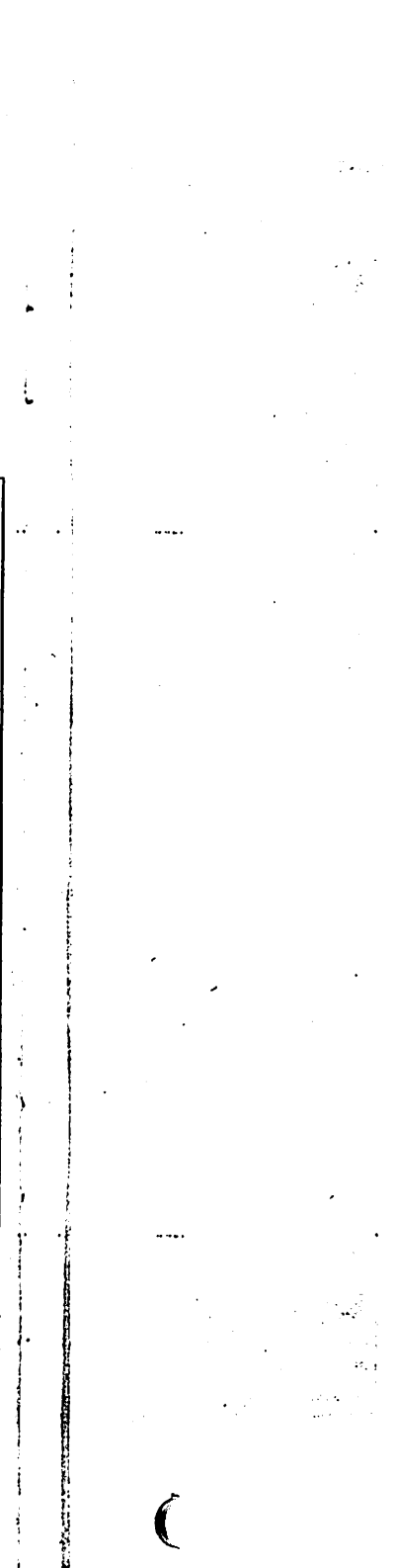
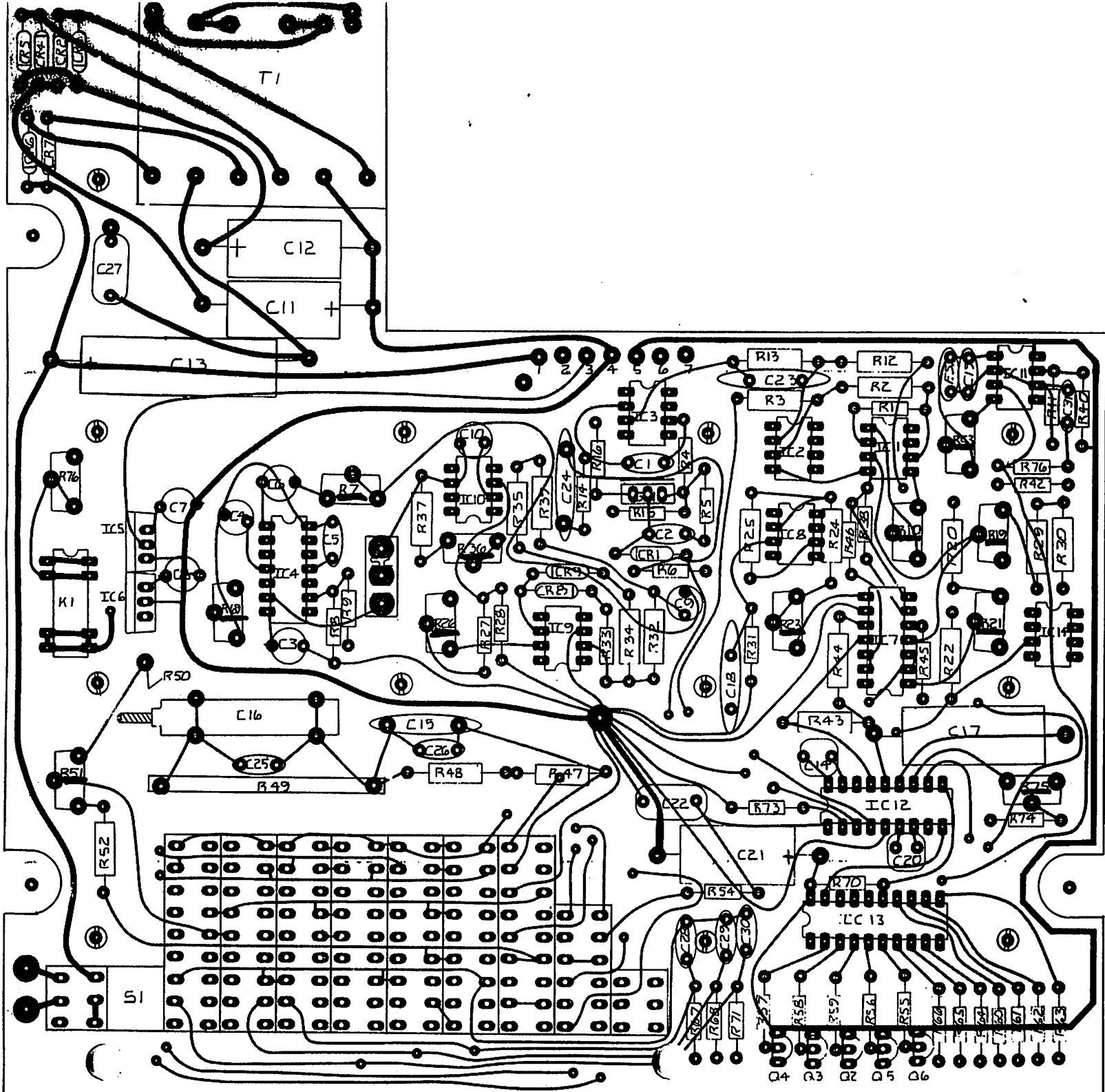

Bad LC2 (4066)
CAN CAUSE TOO HIGH
VIBRUS ON SOME
PLATES.

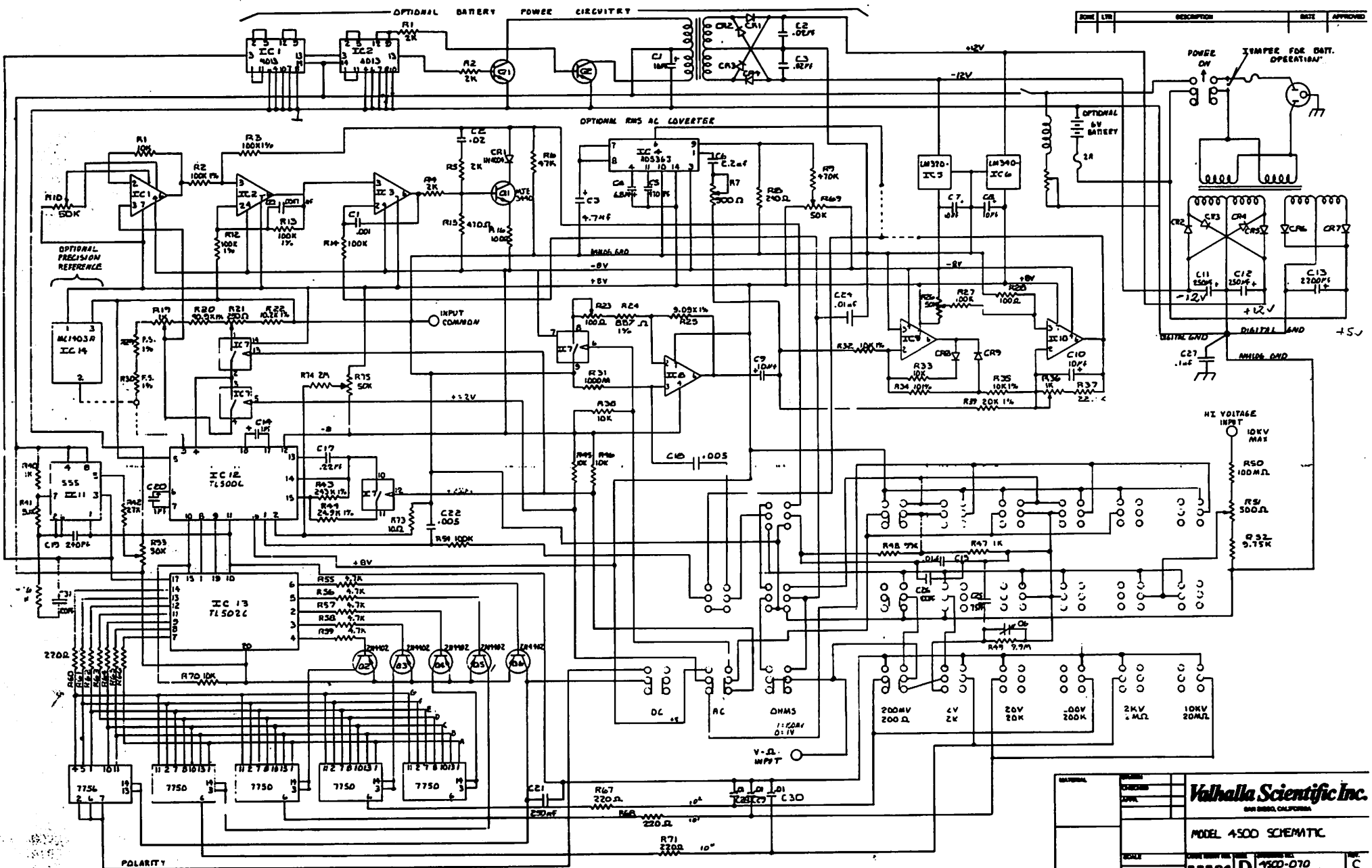

ZONE	LIB	DESCRIPTION	DATE	APPROVED

Valhalla Scientific Inc.
 SAN DIEGO, CALIFORNIA

MODEL 4500 SCHEMATIC

DATE: 888888 D 4500-070

FEDERAL SUPPLY CODE
for
MANUFACTURERS CATALOGING HANDBOOK H4-1

00001 Monsanto, Electronic Special Products, Cupertino, Calif.
00656 Aerovox Corporation, New Bedford, Mass
00853 Sangamo Electric Company, Pickens, S.C.
01121 Allen-Bradley Company, Milwaukee, Wisc.
01255 Litton Industries, Inc., Beverly Hills, Calif.
01281 T R W Semiconductors, Inc., Lawndale, Calif.
01295 Texas Instruments, Inc., Dallas, Texas
02335 Fairchild Controls Corp., Hicksville, L.I., N.Y.
02660 Amphenol Corporation, Broadview, N.Y.
03507 General Electric Company, Syracuse, N.Y.
04713 Motorola Semiconductor Prod., Inc., Phoenix, Ariz.
04963 3-M, St. Paul, Minn.
05276 Pomona Electronics Co., Inc., Pomona, Calif.
05397 Kemet, Union Carbide Corp., Cleveland, Ohio
05820 Wakefield Engineering, Inc., Wakefield, Mass.
07088 Kelvin Electric Company, Van Nuys, Calif.
07256 Silicon Transistor Corp., Garden City, N.Y.
07263 Fairchild Camera and Instr. Corp., Mt. View, Calif.
07716 I R C, Incorporated, Burlington, Iowa
07910 Continental Devices, Hawthorne, Calif.
08065 Accurate Rubber and Plastics Co., San Diego, Calif.
09026 Babcock Electronics Corp., Costa Mesa, Calif.
12405 Hysol Corporation, El Monte, Calif.
12406 Elpac, Incorporated, Fullerton, Calif.
12697 Clarostat Mfg. Co., Incorporated, Dover, N.H.
13454 Texas Crystals, River Grove, Ill.
14655 Cornell-Dubilier Elect. Corp., Newark, N.J.
14752 Electro Cube, Incorporated, San Gabriel, Calif.
16758 Delco Radio Div., General Motors, Kokomo, Ind.
17838 Mektron, California General, Inc., Chula Vista, Calif.
18324 Signetics, Sunnyvale, Calif.
18722 R C A, Mountaintop, Pa.
21604 Buckeye Stamping Company, Columbus, Ohio
25684 Victoreen Instrument Co., Inc., Oak Lawn, Ill.
27014 National Semi-Conductor Corp., Santa Clara, Calif.
27556 IMB Electronic Products, Santa Fe Springs, Calif.
28480 Hewlett-Packard Co., Palo-Alto, Calif.
30983 Electra/Midland, San Diego, Calif.
44655 Ohmite Manufacturing Company, Skokie, Ill.
71279 Cambridge Thermionic Corp., Cambridge, Mass.
71400 Bussmann Mfg. Div., McGraw-Edison Co., St. Louis, Mo.
71450 CTS Corporation, Elkhart, Ind.
71468 ITT Cannon Electric, Inc., Los Angeles, Calif.
71590 Centralab Div., Globe-Union, Inc., Milwaukee, Wisc.
71785 Cinch Manufacturing Company, Chicago, Ill.
73899 J F D Electronics Company, Brooklyn, N.Y.
75915 Littlefuse, Incorporated, Des Plaines, Ill.
76055 Mallory Controls, Frankfort, Ind.
76493 J. W. Miller Company, Los Angeles, Calif.
78488 Stackpole Carbon Company, St. Marys, Pa.
80294 Bourns, Incorporated, Riverside, Calif.
81095 Triad Transformer Corp., Venice, Calif.
81312 Winchester Electronics, Oakville, Ct.
81349 Military Spec., Standardization Division, Chicago, Ill.
82389 Switchcraft, Incorporated, Chicago, Ill.
83330 Herman H. Smith, Inc., Brooklyn, N.Y.
84171 Arco Electronics, Inc., Great Neck, N.Y.
86684 R C A, Harrison, N.J.
88245 Useco Div., Litton Industries, Van Nuys, Calif.
90201 Mallory Capacitor Company, Indianapolis, Ind.
91637 Dale Electronics, Inc., Columbus, Neb.
91929 Micro Switch Div., Honeywell, Inc., Freeport, Ill.
92194 Alpha Wire Corporation, Elizabeth, N.J.
93332 Sylvania Electric Products, Inc., Woburn, Mass.
98978 IERC, Burbank, Calif.
00002 Jordan Electronics, Van Nuys, Calif.
Val-Sci Valhalla Scientific, Inc., San Diego, Calif.