

PROPRIETARY STATEMENT: ULTRAVOLT INC.  
CONFIDENTIAL DRAWING

B PART NUMBER: BR-007 REV B1 SH 1

REVISIONS				
LTR	DESCRIPTION	BY	DATE	APPD
A	NEW RELEASE	D.S.	99-03-18	J.M.
B	REVISED PER ECO UV3338	CP	09-28-05	S.O.
B1	REVISED PER EC-00510-UV	JC	11/15/07	SRO

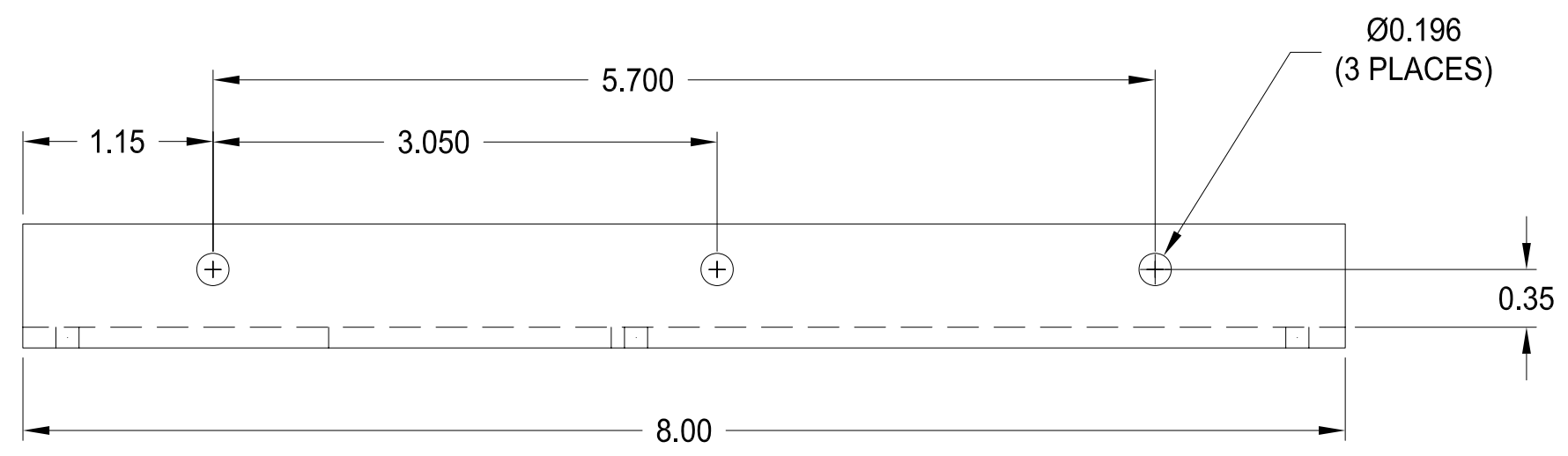
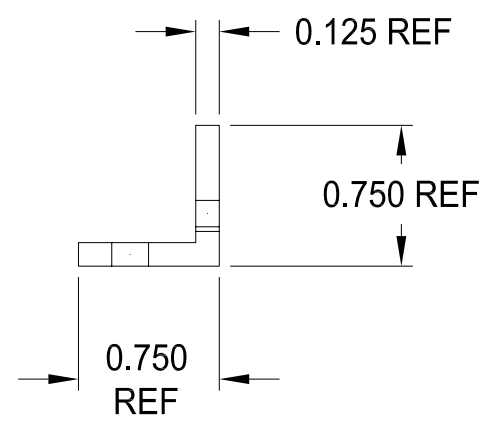
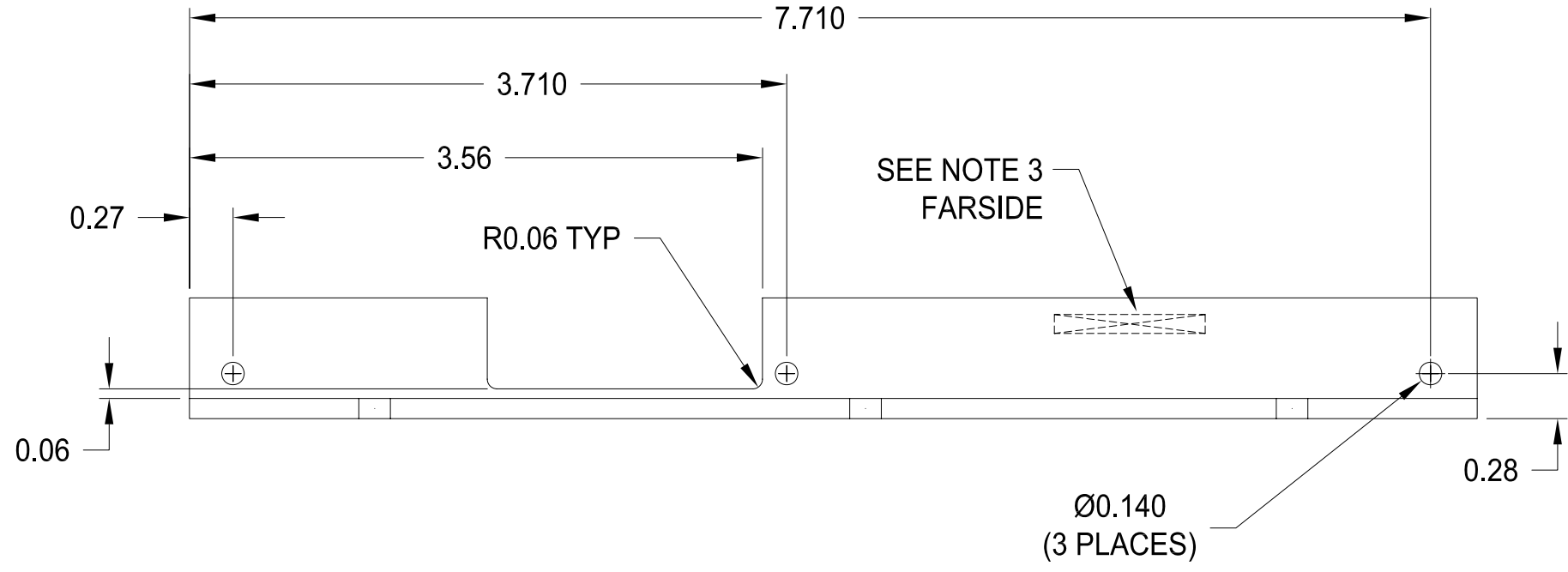

- NOTES:
- MATERIAL: MAKE FROM AL ALLOY 6063 T-5 EXTRUDED, SQUARE CORNERS ANGLE 0.750 x 0.750 x 0.125 THK.
  - FINISH: BLACK ANODIZE PER MIL-A-8625, TYPE II, CL 2.
  - MARK PART NUMBER AND LATEST REVISION. USE A NON-CONDUCTIVE INDELIBLE INK, (FREE OF CARBON) CONTRASTING COLOR. 0.09 - 0.125 HIGH CHARACTERS LOCATE APPROXIMATELY AS SHOWN.
  - REMOVE ALL BURRS AND SHARP EDGES.

UNLESS OTHERWISE SPECIFIED DIMENSION ARE IN INCHES TOLERANCES ARE:		CUSTOMER	
2 PL DEC ± .02	FRACT ± 1/64	DRAWN	D.S.
3 PL DEC ± .010	ANGLES ± 2°	CHKD	F.G.
		MFG	N/A
		MFG ENGR	J.R.O.
		PROCESS	N/A
		QA	N/A
		CHIEF ENG	J. MORRISON
		CFN:	BR-007_revB1.dwg

**ULTRAVOLT, INC.**  
1800 OCEAN AVE. FRNT, RONKONKOMA, N.Y. 11779  
1-631-471-4444

HIGH POWER 'C' SERIES VERTICAL MOUNTING BRACKET  
(BRACKET KIT OPTION ORDER BR-7 KIT)

PART NUMBER: **BR-007** REV **B1**

SCALE NONE DO NOT SCALE THIS DRAWING SHEET 1 OF 1

DASH NUMBER	NEXT ASSY	USED ON
APPLICATION		

