

# EFL SERIES

## Enhanced Floating Hot Deck LVPS With Isolated Digital and Analog I/O

The EFL Series of floating-hot-deck, low-voltage power supplies offers an integrated solution for systems requiring LV power & controls with high-voltage isolation. Combining a highly isolated, DC-to-DC, multi-output low-voltage power supply (LVPS) with an advanced isolated digital & analog I/O topology, the EFL sub-system provides both power and controls to floating-hot-deck circuitry. This solution, when combined with one or more UV HVPS or other circuitry, can provide high-performance solutions for applications such as:



- |                                       |                             |
|---------------------------------------|-----------------------------|
| Floating/Stacked Ion or E-Beam Biases | Floating Filament Bias      |
| Floating Pulsers & Gated Grids        | Floating Capacitance Meters |
| Floating High Side Current Monitors   | Floating Leakage Testers    |

- Precision analog control
- Linearity of  $\pm 0.05\%$  and accuracy of  $\pm 0.2\%$
- 10ppm temperature coefficient
- Isolated up to 15kV or 30kV
- Isolation resistance of 150G $\Omega$  (15kV) or 2G $\Omega$  (30kV)
- 4 regulated floating LV power outputs
- Isolated digital and analog I/O to and from floating hot deck

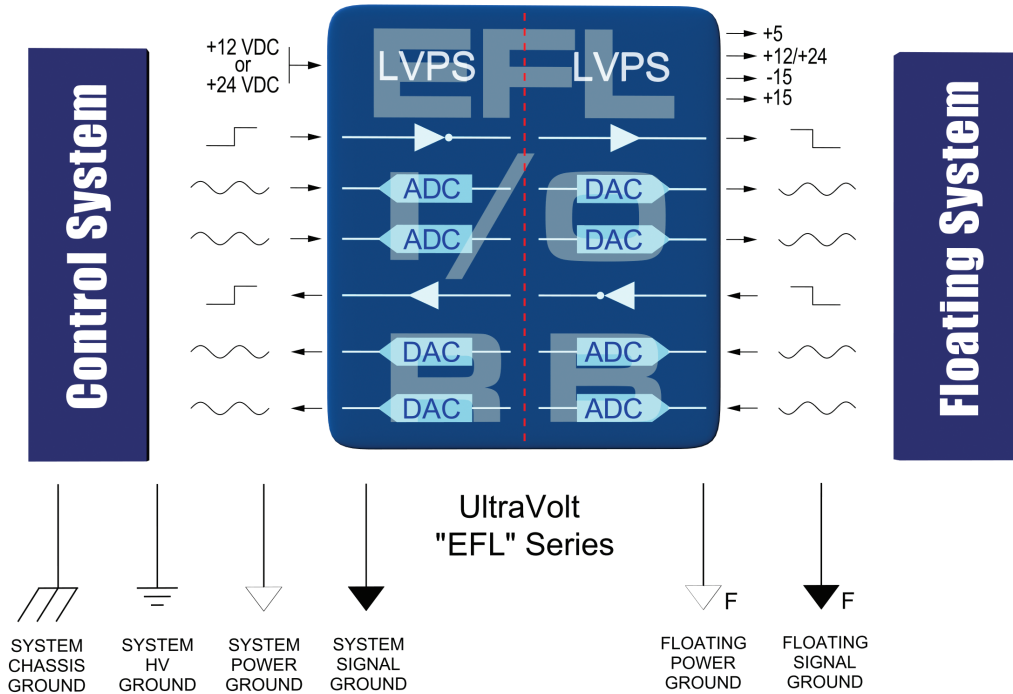

### NORMAL, HALF QUIET, AND QUIET MODES:

All EFLs feature a mode control. Three different models, Normal, Half-Quiet, and Quiet, are selectable via the voltage level at the mode pin. A voltage between -1.0V and +0.8V keeps the unit in Normal mode; the up and down analog channels follow their inputs. If the mode feature is not used, the mode pin must be grounded for the EFL to operate properly.

A voltage more negative than -4.00V places the EFL in Half-Quiet mode. The up channels do not respond to changes in their inputs in Half-Quiet mode.

A voltage greater than +3.75V and less than +5.0V places the EFL in Quiet mode. In Quiet mode, the up and down channels do not respond to changes in their inputs.

The voltage level at the mode pin must not exceed +5.0V at any time. Please contact UltraVolt's customer service department for an analysis of your requirements.

Note: If a voltage  $> 0.8V$  is applied to the mode pin, it must source less than 400uA.

Specifications subject to change without notice.



Making High Voltage Easier!®

Higher Service, Higher Performance, Higher Reliability  
©2011, UltraVolt Inc. All rights reserved.

# EFL SERIES

## Enhanced Floating Hot Deck LVPS With Isolated Digital and Analog I/O

PARAMETER	CONDITIONS	MODELS			UNITS
<b>INPUT POWER</b>		<b>12W</b>	<b>24W</b>	<b>36W (15kV only)</b>	
Voltage Range	Full Power	+12 ± 5%	+24 ± 10%	+24 ± 10%	VDC
Current	Standby ( Disabled )	< 150	< 100	< 100	mA
Current	No Load	< 0.50	< 0.50	< 0.50	A
Current	Max Load	< 2.50	< 2.30	< 3.00	A
AC Ripple Current	Nominal Input, Full Load	< 50	< 50	< 50	mA p-p
<b>LOCAL CONTROLS: REFERENCE</b>		<b>ALL TYPES</b>			
Output Voltage	T = +25°C, Initial value	+5.1 ± 2%			VDC
Output Impedance	T = +25°C	464 ± 1%			Ω
Stability	Over full temperature range	0.4			mV/°C
<b>LOCAL CONTROLS: LVPS ENABLE / DISABLE</b>		<b>ALL TYPES</b>			
Power supply on	Open, or a voltage above TTL high (Isource <400uA)	+3.2 to 5			VDC
Power supply off	Grounded, or a voltage below TTL low	< 0.8 (Isink 1mA minimum)			VDC
<b>INPUT / OUTPUT ISOLATION:</b>		<b>15EFL</b>	<b>30EFL</b>		
Isolation Voltage	Continuous	15	30		kV
Isolation Resistance	All inputs to all outputs	150	2		GΩ
Leakage Capacitance	All inputs to all outputs	< 40 std, < 50 "E"	< 40 std.		pF
<b>ISOLATED POWER OUTPUTS:</b>		<b>12W</b>	<b>24W</b>	<b>36W (15kV only)</b>	
Output #1 Power	Nominal input, max lout	12	24	36	W
Output #1 Voltage	Nominal input voltage range	+12 ± 2%	+24 ± 2%	+24 ± 2%	VDC
Output #1 Current	Minimum to Maximum	0 to 1	0 to 1	0 to 1.5	A
Output #1 Line Regulation	Nominal input range, full load	< 0.1 %	< 0.1 %	< 0.1 %	VDC
Output #1 Load Regulation	No load to full load	< 0.25 %	< 0.30 %	< 0.40 %	VDC
Output #1 Ripple	Full load	< 2.5 %	< 1.5 %	< 1.5 %	V p-p
Output #2 & #4 Voltage	Nominal input voltage range	±15 ± 5 %	±15 ± 5 %	±15 ± 5 %	VDC
Output #2 & #4 Current	Minimum to Maximum	0 to 50	0 to 50	0 to 50	mA
Output #2 & #4 Line Regulation	Nominal input range, full load	< 0.3 %	< 0.3 %	< 0.3 %	VDC
Output #2 & #4 Load Regulation	No load to full load	< 5 %	< 1 %	< 1 %	VDC
Output #2 & #4 Ripple	Full load	< 2.5 %	< 2.5 %	< 2.5 %	V p-p
Output #3 Voltage	Nominal input voltage range	+5.1 ± 1%	+5.1 ± 1%	+5.1 ± 1%	VDC
Output #3 Current	Minimum to Maximum	500	500	500	mA
Output #3 Line Regulation	Nominal input range, full load	< 1 %	< 1 %	< 1 %	VDC
Output #3 Load Regulation	No load to full load	< 1 %	< 1 %	< 1 %	VDC
Output #3 Ripple	Full load	< 4 %	< 4 %	< 4 %	V p-p
<b>ISOLATED CONTROLS: TTL CHANNEL "UP"</b>		<b>ALL TYPES</b>			
Local input	Source voltage, sink current	0 ≤ 0.5 (Isink 3mA minimum) 1 ≥ 2.4 (300uA max or open collector)			VDC
Isolated output	Inverted & buffered TTL	1 ≥ 2.4, 0 ≤ 0.55 ± (Sources 0.8 mA, Sinks 3 mA)			VDC
Baud Rate	Duty cycle	< 15			ms
<b>ISOLATED CONTROLS: ANALOG CHANNEL "UP"*</b>		<b>12V</b>	<b>24V</b>		
Local input voltage	Range	0 to + 5	0 to + 10		VDC
Isolated output voltage	Range	0 to + 5	0 to + 10		VDC
Local input impedance		20.0 K			Ω
Initial offset error		< ± 2			mV
Gain error	Full scale	< ± 0.2 %			VDC
Linearity error	Full scale	< ± 0.05 %			VDC
Stability	30 min. warm-up, per 8 hrs / per day	< 0.02%			VDC
Temperature Coefficient	0 to +55 °C	< ± 10			ppm/°C
Bandwidth	Symmetric or asymmetric signal	DC to 4			Hz

\*Note: Analog Channel UP parameters are valid for outputs in the range of 10% to 100% of maximum.



Making High Voltage Easier!®

1800 Ocean Avenue, Ronkonkoma, NY 11779  
Phone: 1-631-471-4444 Fax: 1-631-471-4696 www.ultravolt.com

# EFL SERIES

Enhanced Floating Hot Deck LVPS With Isolated Digital and Analog I/O

'-RB' ISOLATED CONTROLS: TTL CHANNEL "DOWN"			
PARAMETER	CONDITIONS	ALL TYPES	UNITS
Isolated 'Hot Deck' Input	Source voltage, sink current	0 ≤ 0.5 (Isink 1mA Minimum) 1 ≥ 2.4 (300uA max or open collector)	VDC
Local output	Inverted & Buffered TTL	1 > 2.4 (Sources 0.8mA) 0 < 0.55 (Sinks 10mA)	VDC
Propagation Delay	Duty cycle	< 15	ms
ISOLATED CONTROLS: ANALOG CHANNELS #1 & #2 "DOWN"**			
PARAMETER	CONDITIONS	ALL TYPES	UNITS
Isolated 'Hot Deck' +Input	Range	0 to +5 for 12V and 0 to +10 for 24V	VDC
Isolated 'Hot Deck' -Input	Range	0 to -5 for 12V and 0 to -10 for 24V	VDC
Isolated 'Hot Deck' + or - Input impedance	Signal source	> 10	MΩ
Local output +voltage	Range	0 to +5 for 12V and 0 to +10 for 24V	VDC
Local output -voltage	Range	0 to -5 for 12V and 0 to -10 for 24V	VDC
Initial offset error	Signal source	< ± 2	mVDC
Gain error	Full scale	< ± .2%	VDC
Linearity error	Full scale	< ± .05%	VDC
Stability	30 min. warm-up, per 8 hrs / per day	< 0.01% / < 0.02%	VDC
Temperature Coefficient	-20 °C to +55 °C	< ± 10	ppm/°C
Bandwidth	Symmetric or asymmetric signal	DC to 4	Hz
TEMPERATURE:			
PARAMETER	CONDITIONS	ALL TYPES	UNITS
Operating	Full load, case measurement	-20 to +55	°C
Storage	Non-operating, case measurement	-55 to +85	°C
Thermal shock	Mil-Std-810, Method 503-4, Proc. II	-20 to +55	°C
ALTITUDE:			
PARAMETER	CONDITIONS	ALL TYPES	UNITS
Operating	All operating conditions	Sea level to Vacuum	-
Storage	Non-operating	Sea level to Vacuum	-
SHOCK & VIBRATION:			
PARAMETER	CONDITIONS	ALL TYPES	UNITS
Shock	Mil-Std-810, Method 516.5, Proc IV	20	G's
Vibration	Mil-Std-810, Method 514.5, Fig. 514.5C-3	10	G's

\*\*Note: Analog Channels #1 & #2 DOWN parameters are valid for outputs in the range of 10% to 100% of maximum.

LOCAL CONNECTIONS	
PIN	FUNCTION
1	Input Power Ground Return
2	Positive Power Input
3	LVPS Enable/Disable/Sync In
4	TTL Up
5	Signal Ground Return
6	Analog Up Channel 1
7	+5V Reference Output
8	Analog Down Channel 1, +
9	Analog Down Channel 1, -
10	Analog Down Channel 2, +
11	Analog Down Channel 2, -
12	Analog Up Channel 2
13	Mode
14	TTL Output (Inverted Digital Down Channel 1)

ISOLATED/FLOATING CONNECTIONS	
PIN	FUNCTION
1	Analog Down Channel 1, +
2	Analog Down Channel 1, -
3	Analog Down Channel 2, +
4	Analog Down Channel 2, -
5	+15VDC Output
6	Analog Up Channel 2
7	Floating TTL input (Digital Down Channel 1)
8	Floating PWR Ground Return
9	Floating +12VDC or +24VDC Output
10	Floating -15VDC Output
11	Floating TTL Up
12	Floating Signal Ground Return
13	Floating Analog Up Channel 1
14	Floating +5.1VDC Reference Output



Making High Voltage Easier.®

1800 Ocean Avenue, Ronkonkoma, NY 11779  
Phone: 1-631-471-4444 Fax: 1-631-471-4696 www.ultravolt.com

# EFL SERIES

Enhanced Floating Hot Deck LVPS With Isolated Digital and Analog I/O

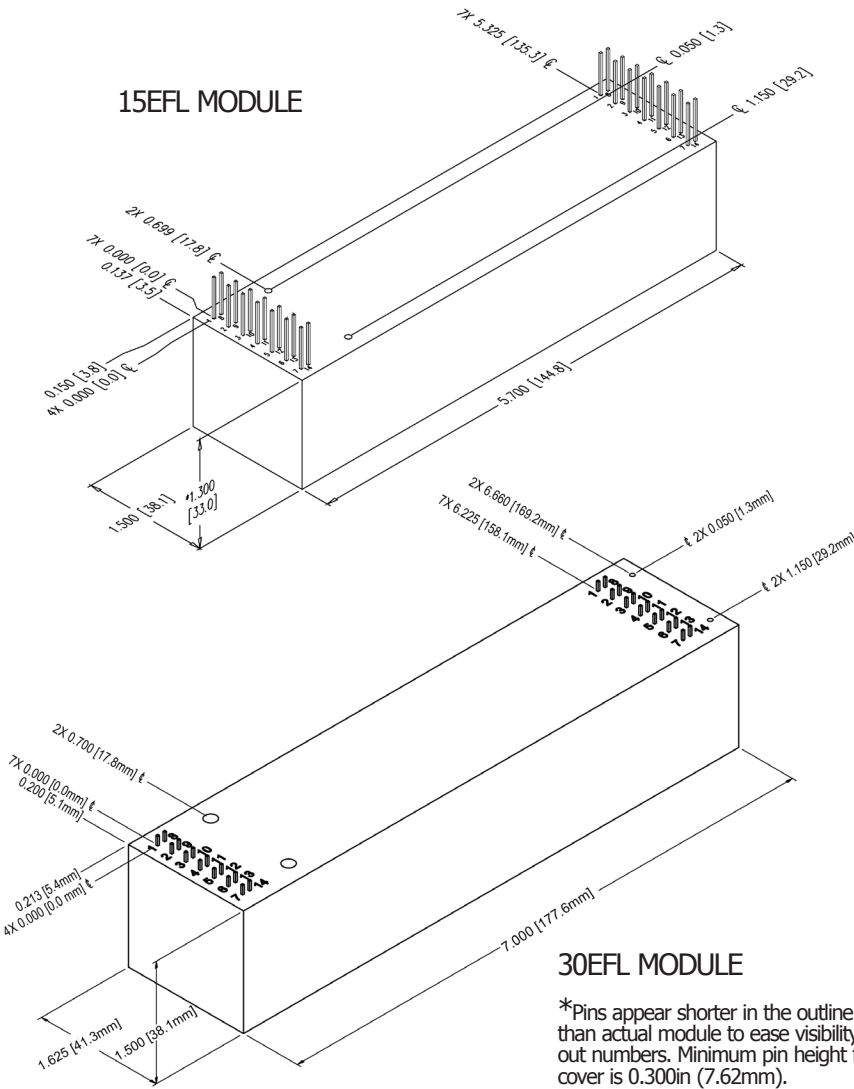

\*Pins appear shorter in the outline drawing than actual module to ease visibility of pin out numbers. Minimum pin height from the cover is 0.300in (7.62mm).

## CONSTRUCTION

Epoxy-filled DAP box certified to ASTM-D-5948

## SIZE

Volume:  
 15EFL: 11.1 in<sup>3</sup> (181.9cc)  
 30EFL: 16.8 in<sup>3</sup> (275.3cc)

Weight:  
 15EFL: 13.3 oz (377.1g)  
 30EFL: 20.1 oz (569.8g)

## TOLERANCE

Overall  $\pm 0.050''$  (1.27)  
 Pin to Pin  $\pm 0.015''$  (0.38)  
 15EFL: Mounting hole locations  $\pm 0.025''$  (0.64)  
 30EFL: Mounting hole locations  $\pm 0.030''$  (0.76)

## NOTES

15EFL: 24W and 36W versions are an additional 0.062" (1.57) in height. Contact UV Customer Service for drawings of models equipped with -E option.  
 30EFL: 24W version is an additional 0.073" (1.85) in height.  
 All Types: -M equipped units are an additional 0.030" (0.76) in height.

Downloadable drawings (complete with mounting & pin information) and 3D models are available online.



Non-RoHS compliant units are available. Please contact the factory for more information.

## ORDERING INFORMATION

Type	15kV Isolation	15EFL
	30kV Isolation	30EFL
Input Voltage	12VDC Nominal	12
	24VDC Nominal	24
Power	Watts Output (12Vin Only)	-12W
	Watts Output (24Vin Only)	-24W
	Watts Output (15kVout, 24Vin Only)	-36W
Standard Features	(1) Digital Up Channel & (2) Analog Up Channels	-I/O
	(1) Digital Down Channel & (2) Analog Down Channels	-R/B
Options	Partial Mu-Metal Shield	-M
Case	Plastic Case - Diallyl Phthalate	Standard
	'Eared' Chassis Mounting Plate (15kV only)	-E

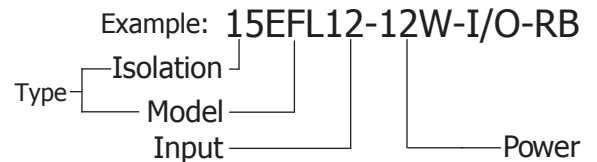

Rev. G 7/13



Making High Voltage Easier!®

1800 Ocean Avenue, Ronkonkoma, NY 11779  
 Phone: 1-631-471-4444 Fax: 1-631-471-4696 www.ultravolt.com