

PROPRIETARY STATEMENT: ULTRAVOLT INC.
CONFIDENTIAL DRAWING

REVISIONS				
LTR	DESCRIPTION	BY	DATE	APPD
1	PROTOTYPE	SRO	7/3/02	DP
A	REVISED PER EC-00510-UV	JC	11/15/07	SRO

B

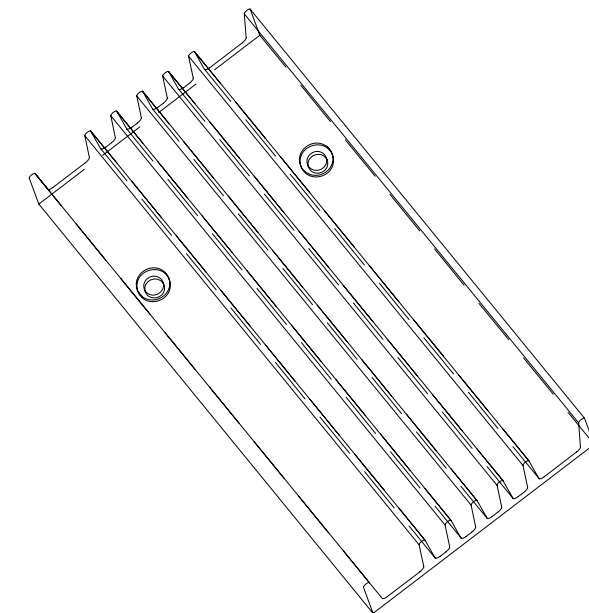
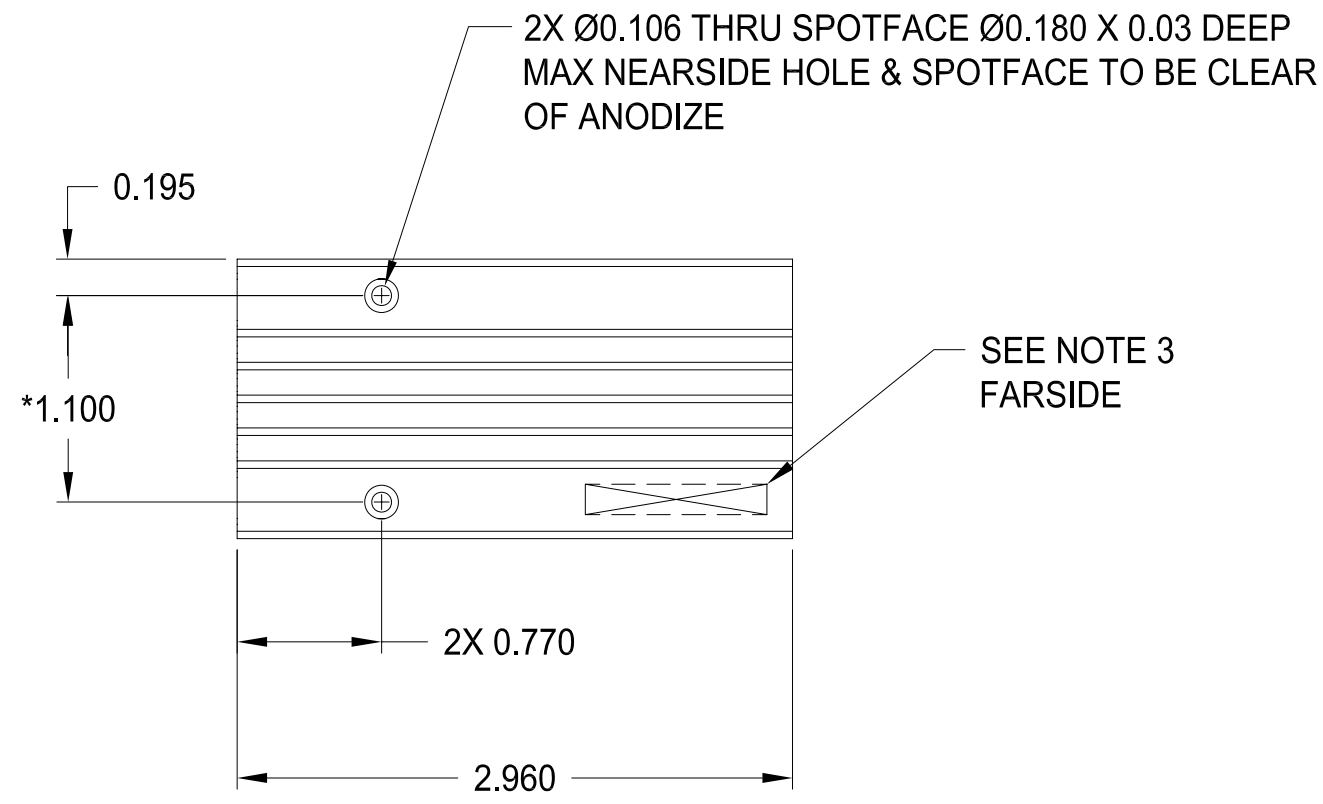
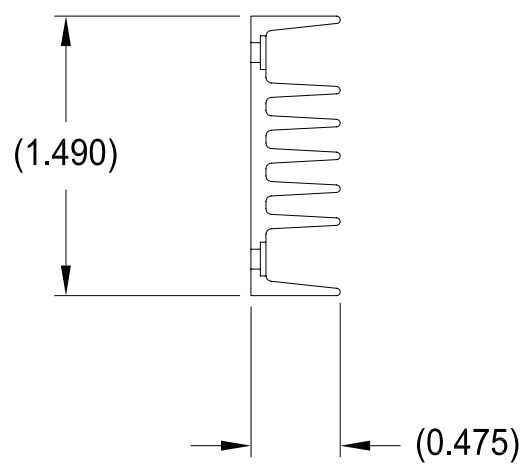

B

- NOTES:
- 1- MATERIAL: MAKE FROM ULTRAVOLT P/N: EX-001.
 - 2- FINISH: BLACK ANODIZE PER MIL-A-8625, TYPE II, CLASS 2.
 - 3- MARK PART NUMBER AND REVISION. STAMP OR USE A NON-CONDUCTIVE INDELIBLE INK, (FREE OF CARBON) CONTRASTING COLOR, OR STAMP 0.09 - 0.125 HIGH CHARACTERS LOCATE APPROXIMATELY AS SHOWN, FARSIDE. ie. XX-XXX_revX
 - 4- REMOVE ALL BURRS AND SHARP EDGES.
 - 5- DIMENSIONS WITH ASTERISK (*) TOLERANCE ARE ±0.005.
 - 6- EXPOSED SURFACE AREA WHEN MOUNTED = 19.84 in²
 - 7- WEIGHT OF HEATSINK 0.078 LBS.

A

A

UNLESS OTHERWISE SPECIFIED DIMENSION ARE IN INCHES TOLERANCES ARE:		CUSTOMER	
2 PL DEC ± .02	FRACT ± 1/64	DRAWN	SRO
3 PL DEC ± .010	ANGLES ± 2°	CHKD	D.S.
		DATE	7/3/02
		8/26/02	
		MFG	N/A
		MFG ENGR	D. PARANT
		DATE	8/26/02
		PROCESS	N/A
		QA	TONY CHLIEK
		DATE	9/3/02
		CHIEF ENG	J.M.
		DATE	9/6/02
		CFN:	HS-027_revA.dwg

ULTRAVOLT, INC.
1800 OCEAN AVE. FRNT, RONKONKOMA, N.Y. 11779
1-631-471-4444

HEAT SINK, FINNED
"AA" SERIES

PART NUMBER: **HS-027** REV **A**

SCALE NONE DO NOT SCALE THIS DRAWING SHEET 1 OF 1

DASH NUMBER	NEXT ASSY	USED ON
APPLICATION		