

0.00" 0.25" 0.50" 0.75" 1.00" 1.25" 1.50" 1.75" 2.00"

PROPRIETARY STATEMENT: ULTRAVOLT INC.
CONFIDENTIAL DRAWING

B PART NUMBER: OL-017 REV A SH 1

REVISIONS				
LTR	DESCRIPTION	BY	DATE	APPD
A	RELEASED PER EC-01036-UV	A.S.	07/26/10	GM

B

A

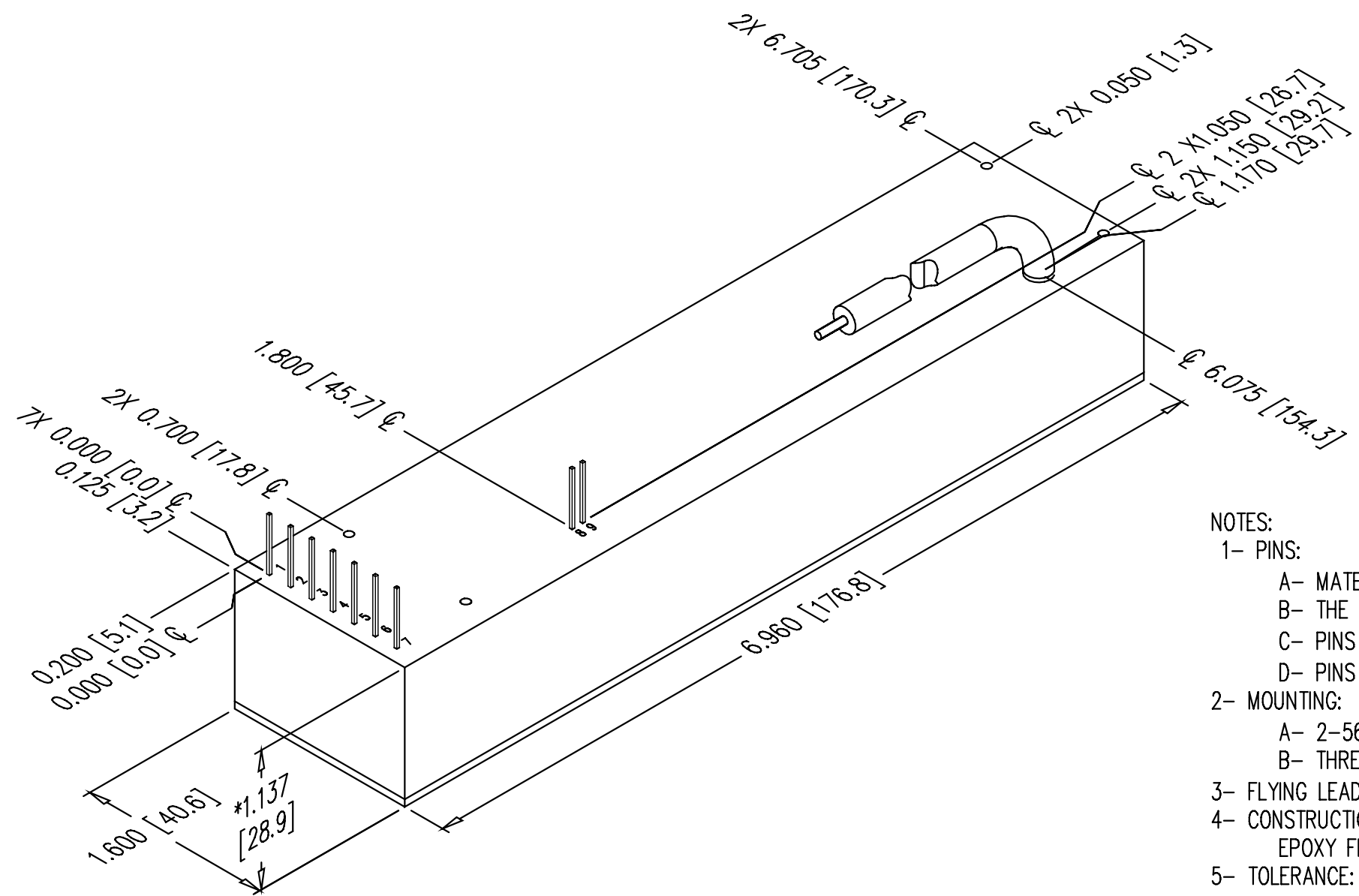

NOTES:

- 1- PINS:
 - A- MATERIAL: GOLD PLATED 0.025 [0.64] SQ.
 - B- THE CENTER OF THE PINS AND MOUNTING HOLES ARE LOCATED FROM THE CENTER OF PIN 1.
 - C- PINS 1 THRU 7 SPACING 0.200 [5.08] ON CENTER, HEIGHT FROM COVER 0.370 [9.4] MIN
 - D- PINS 8, 9 SPACING 0.100 [2.54] ON CENTER, HEIGHT FROM COVER 0.370 [9.4] MIN
- 2- MOUNTING:
 - A- 2-56 X 0.30 [7.62] DP UNC-2B THD 4 PLACES.
 - B- THREADED POST MAY NOT BE FLUSH TO COVER.
- 3- FLYING LEAD ϕ 0.210 [5.33] MAX. APPROX. 18.00 [457.2] LONG
- 4- CONSTRUCTION:
 - EPOXY FILLED DAP BOX CERTIFIED TO ASTM-D-5948
- 5- TOLERANCE:
 - A- OVERALL +/-0.050 [1.27]
 - B- PIN TO PIN +/-0.015 [0.38]
 - C- MOUNTING HOLE LOCATION +/- 0.025 [0.64]
- *6- -M EQUIPPED UNITS ARE AN ADDITIONAL 0.030 [0.76] IN HEIGHT.



UNLESS OTHERWISE SPECIFIED DIMENSION ARE IN INCHES TOLERANCES ARE: 2 PL DEC ± .02 FRACT ± 1/64 3 PL DEC ± .010 ANGLES ± 2'			CUSTOMER		ULTRAVOLT, INC. 1800 OCEAN AVE. FRNT, RONKONKOMA, N.Y. 11779 1-631-471-4444 OUTLINE 30A / 35A SERIES
HOLE DIA			DRAWN <i>S. Orban</i> DATE 02/04/02 CHKD <i>D. Parant</i> 3/20/02	MFG <i>N/A</i> MFG ENGR <i>N/A</i> PROCESS <i>N/A</i> QA <i>N/A</i> CHIEF ENG <i>N/A</i>	
.0135 THRU .125			B PART NUMBER: OL-058 REV A		
.126 THRU .250					
.251 THRU .500					
.501 THRU .750					
.751 THRU 1.000			CFN: OL-058_revA_30A-35A.dwg		SCALE NONE
1.001 THRU 2.000					DO NOT SCALE THIS DRAWING
DASH NUMBER	NEXT ASSY	USED ON	SHEET 1 OF 1		
APPLICATION					

2

1