

TF SERIES

High Voltage Test Fixture

The TF Series product line is designed to support the need to make accurate measurements of high-voltage power supply (HVPS) & HV system performance. These reduced-size HV test fixture devices can be used for research and development, incoming inspection, production testing, field testing, or calibration. Each TF Series device, when coupled with a conventional meter or oscilloscope, is a stand-alone test fixture optimized for a specific HV testing function. The TF Series is engineered to support accurate measurement of ripple, noise, pulses, absolute DC, DC stability, DC line regulation, DC load regulation, etc.

- Make accurate HV in-line measurements
- View and measure AC ripple & noise on DC HV
- Measure absolute HV DC to 0.25% @ 25 PPM stability
- View and measure T_{rise} , T_{fall} , overshoot & settling time
- Measure & monitor signals from 35Hz to 10MHz
- View signals from DC to 20MHz
- View and measure AC mV on DC kV
- PLC Analog/Digital Remote operation capability

KEY FEATURES:

The UltraVolt TF Series models all feature dual Alden B110YX10 HV connectors. These connectors facilitate in-line measurements as well as un-terminated measurements. Internal ARC limiting / softening resistors are present for safety. All TF models have the HV ground return connection isolated from the chassis ground connection by 100k Ω and clamped by a protection device.

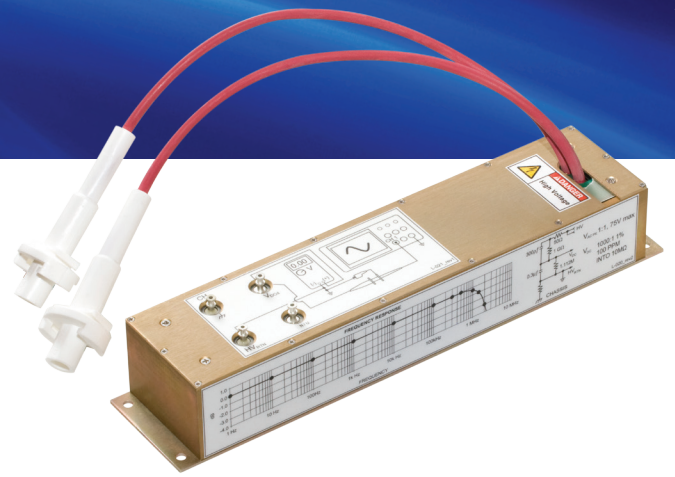

SPECIFICATIONS:

All specifications are subject to change without notice. UltraVolt will enhance specifications whenever possible, through continuous product and process improvement efforts. Customers are not contacted when changes are made unless they have arranged for configuration control with UltraVolt's customer service department ("CSD") through the "-Q" suffix program. Only the most significant items will be noted on UltraVolt's web site, in the product change notice section.

ALTITUDE, HUMIDITY & TEMPERATURE:

The TF Series operating performance is guaranteed between sea level and 10,000ft., in non-condensing relative humidity up to 95%, and between temperatures of -40°C to +65°C. Storage temperature range is -55°C to +105°C.

TF SERIES MODELS:

"Precision Divider": 40TF-DCD

A 40kV rated HV Test Fixture that features a precision 10,000:1 DC divider ("DCD") with a full scale accuracy of $\pm 1\%$, a temperature stability of better than ± 25 ppm per $^{\circ}\text{C}$, and a voltage coefficient of $< 1\%$ per 40,000 volts. DC Loading is 1 Gig Ω . Capacitive loading is < 10 pF.

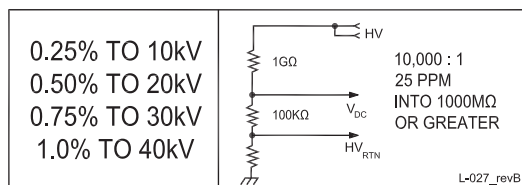

Fig. A - Accuracy & Equivalent Circuit (Precision Divider)

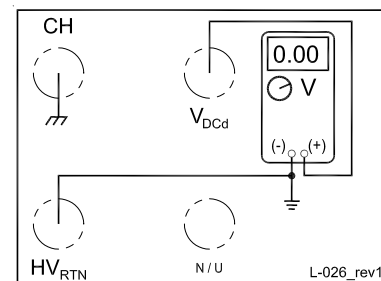

Fig. B - Electrical Connections (Precision Divider)

⚠ WARNING! A shock hazard exists when the chassis ground or the HV return ground is not properly connected! ⚠

Specifications subject to change without notice.



Making High Voltage Easier!®

Higher Service, Higher Performance, Higher Reliability

©2011, UltraVolt Inc. All rights reserved.

TF SERIES

High Voltage Test Fixture

“Ripple & Voltage Monitor”: 40TF-ACV&DCD

A 40kV rated HV Test Fixture that features a 1:1 AC viewing (ACV) capacitor ($V_{AC}=95\%$ of V_{AC} input $\pm 5\%$) providing a bandwidth of 35Hz to 10MHz (Monitor 10Hz to 20MHz) over a signal range of 1mV to 75V Pk, along with a 1,000:1 DC divider (“DCD”) with a full scale accuracy of $\pm 2\%$ and a temperature stability of better than ± 100 ppm per $^{\circ}\text{C}$. DC Loading is 2 Gig Ω . Capacitive loading is $< 50\text{pF}$.

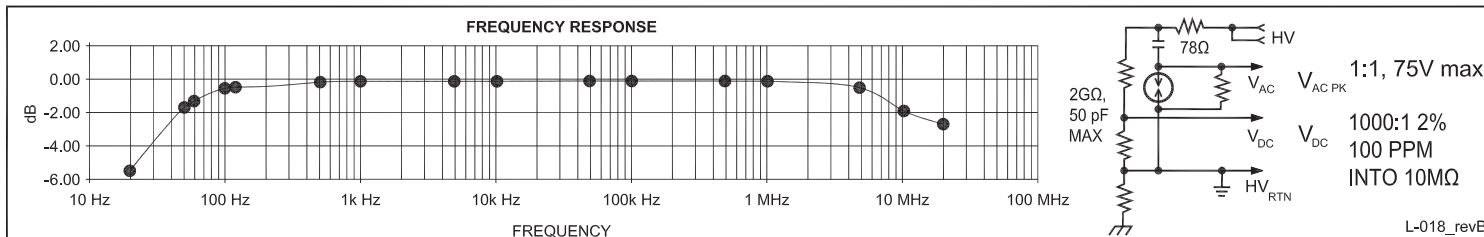

Note: It is recommended that the oscilloscope be set for 20MHz BW limit.
Fig. C - Bandwidth & Equivalent Circuit (Ripple & Voltage Monitor)

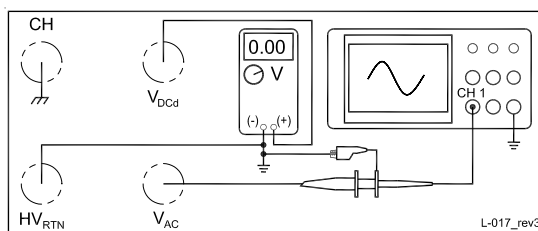
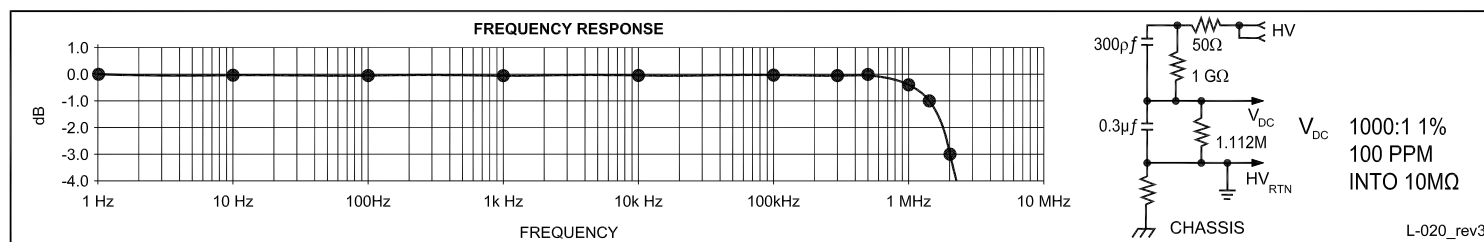

Fig. D - Electrical Connections (Ripple & Voltage Monitor)

⚠ WARNING! A shock hazard exists when the chassis ground or the HV return ground is not properly connected! ⚠

“Compensated Divider”: 40TF-CDCD&CLOAD

A 40kV rated HV Test Fixture that features a compensated 1,000:1 Compensated DC Divider (“CDCD”) capable of showing T_{rise} , T_{fall} , overshoot & settling over a bandwidth of DC to 2MHz. The unit also functions as a 300pF capacitive load (“CLOAD”). DC Loading is 1 Gig Ω . DC full-scale accuracy is $\pm 2\%$ with temperature stability of better than ± 100 ppm per $^{\circ}\text{C}$.



Note: It is recommended that the oscilloscope be set for 20MHz BW limit.
Fig. E - Bandwidth & Equivalent Circuit (Compensated Divider)

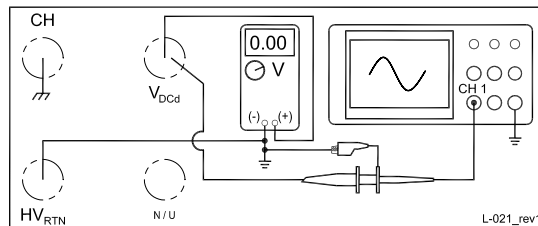

Fig. F - Electrical Connections (Compensated Divider)

⚠ WARNING! A shock hazard exists when the chassis ground or the HV return ground is not properly connected! ⚠



Making High Voltage Easier!®

1800 Ocean Avenue, Ronkonkoma, NY 11779
Phone: 1-631-471-4444 Fax: 1-631-471-4696 www.ultravolt.com

TF SERIES

High Voltage Test Fixture

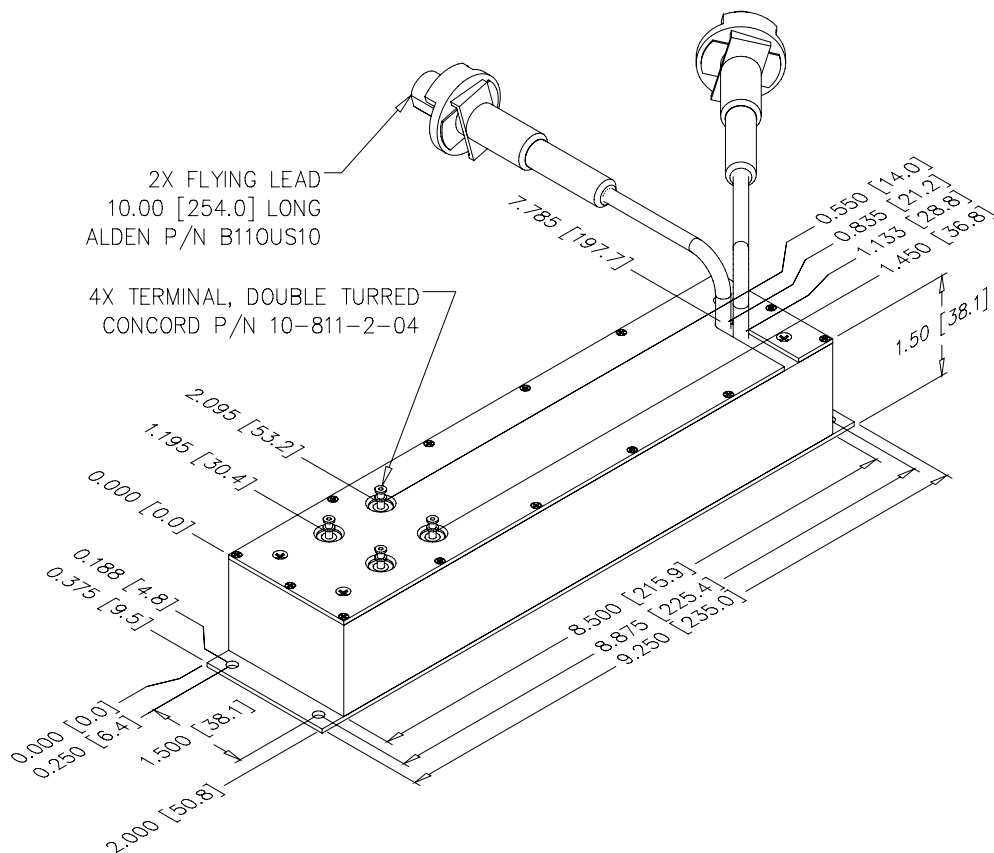

CONSTRUCTION

Aluminum Box Anodize Gold

SIZE

Volume 27.75in³ (454.74cc)
 Weight 1.65Lbs. (748.43g)

TOLERANCE

Overall ±0.050" (1.27)
 Pin to Pin ±0.015" (0.38)

[Downloadable drawings \(complete with mounting & pin information\) and 3D models are available online.](#)

ORDERING INFORMATION	
TYPE	DESCRIPTION
40TF-DCD	Precision divider
40TF-ACV&DCD	Ripple and voltage monitor
40TF-CDCD&CLOAD	Compensated divider

Popular accessories ordered with this product include our full range of high voltage output connectors (see Accessories & Connectors datasheet).



Non-RoHS compliant units are available. Please contact the factory for more information.

Manufactured in USA

Rev. J 10/14



Making High Voltage Easier!®

1800 Ocean Avenue, Ronkonkoma, NY 11779
 Phone: 1-631-471-4444 Fax: 1-631-471-4696 www.ultravolt.com