

# SYSTEMS

## PRODUCT CATALOG 2014



Rack Mounts - Benchtops - Multi-Module Solutions - Test Fixtures

 **ULTRAVOLT**®  
*Making High Voltage Easier!*®

# TABLE OF CONTENTS

## HIGH VOLTAGE POWER SYSTEMS

### RACK MOUNT HIGH VOLTAGE POWER SYSTEMS



HV Rack Configurable Series	19" rack mounted/benchttop high-voltage power system HV output of 4W to 1000W per channel (1000W max for entire system) 1 to 4 configurable channels with independent control & monitoring	4
HCP Series	Floating output voltage up to 300kV Output power from 0 to 12W up to 15kW Voltage and current monitors on all models Multiple computer interfaces available	7
MCP Series	Floating output voltage up to 2kV Output power from 0 to 14W up to 15kW Voltage and current monitors on all models Multiple computer interfaces available	10



### HIGH VOLTAGE CASSETTE POWER SUPPLIES

HCE Series	Compatible with Euro cassette rack & 19" rack chassis 0 to 125V through 35kV Up to 350W of Power Input of 115VAC or 230VAC	12
------------	---	----



### HIGH VOLTAGE/POWER CABINET SYSTEMS

HPV Series	Output voltage from 0 to 60kV through 200kV Output power from 0 to 6kW through 60kW Single-output & multi-output configurations available	15
------------	---	----

### BENCHTOP HIGH VOLTAGE POWER SYSTEMS

BT-GP Series	General Purpose benchtop high-voltage power system from 0 to 1kV through 0 to 30kV at 30W of output power AC model with universal input 90-260 VAC DC model with input of 24 VDC	17
--------------	---	----



Failure to operate UltraVolt High Voltage Power Supplies correctly and to follow all operating instructions may create an electrical shock hazard, which can result in personal injury or loss of life, and/or damage to equipment or other property.

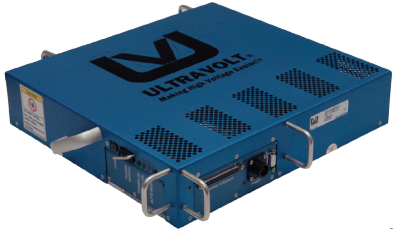

MULTI-MODULE SOLUTION POWER SYSTEMS

MMS-eB Series .....19

High-voltage power system optimized for electron guns  
 Exceptional stability and ultra-low noise  
 3-, 4- or 5- bias electron gun for beam, filament, extractor, suppressor, & lens voltages  
 Half-quiet and Full-quiet mode capability

TEST FIXTURES

TF Series Test Fixtures for accurate HV in-line measurements .....22

View and measure AC ripple & noise,  $T_{rise}$ ,  $T_{fall}$ , overshoot & settling time  
 Measure HV DC stability, drift, and regulation

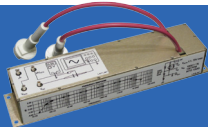

SAFETY, COMPLIANCES, & WARRANTY

Safety and compliance information along with warranty & repair policy .....25

 Failure to operate UltraVolt High Voltage Power Supplies correctly and to follow all operating instructions may create an electrical shock hazard, which can result in personal injury or loss of life, and/or damage to equipment or other property.

# HV RACK® CONFIGURABLE SERIES

## Rack Mount High Voltage Power System

The HV Rack Configurable power system is a fully featured, configurable chassis, enabling end users to select and to specify the UltraVolt high-voltage power supply (HVPS) operating in each channel from UltraVolt's catalog of more than 600 models. This combination provides accurate control and measurement of high-voltage power supply and HV system performance.

- 1 to 4 configurable high-voltage output channels
- Voltage ranges from 0 to 62VDC through 40kV
- 4 to 1000 watts per channel, up to 1000 watts total
- Independent control & monitoring of each channel



- Voltage and Current meters for each channel
- Constant current / Constant voltage auto-crossover
- Pre-set before & during bias capability
- PLC Analog/Digital Remote operation capability

PARAMETER	CONDITIONS	MODELS			
AC INPUT		HV RACK X-250	HV RACK X-500	HV RACK X-750	HV RACK X-1000
Voltage	Full Power, Autoswitching	115/230VAC, 50/60Hz	115/230VAC, 50/60Hz	230VAC, 50/60Hz	230VAC, 50/60Hz
Power	120VAC, Max Eout, Full Load	375W	750W	N/A	N/A
Power	240VAC, Max Eout, Full Load	375W	750W	1125W	1500W
REMOTE CONTROL		ALL MODELS			
Enable	All Channels	TTL high to enable, low to disable (DEFAULT IS DISABLE)			
V Control	All Channels	0V to 4.64V = 0V to 100% HV out (5V = 108% HV out)			
HV Monitor	All Channels	0V to 4.64V = 0V out to 100% V out (5V = 108% V out)			
I Control	All Channels	0V to 4.64V = 0A to 100% I (5V = 108% I)			
I Monitor	All Channels	0V to 4.64V = 0A to 100% I (5V = 108% I)			
Reference Out	All Channels	5V precision voltage reference returned to signal ground			
LVPS Out	One Signal, PTC Fused	+15V±10%, 0 to 100mA			
Power Ground	One Signal	Return of LVPS Out			
Global Disable	One Signal	TTL signal disables all Channels, low to enable, high to disable (DEFAULT IS ENABLE)			
OUTPUT METERS		TYPE OF CHANNEL		TOLERANCE	
Voltage	4½ Digit Red LED	All		1% Full Scale	
Current	3½ Digit Blue LED	All		1% Full Scale	
TEMPERATURE		ALL MODELS			
Operating	Full Load, Max Eout, Case Temp.	+10°C to +45°C			
Storage	Non-Operating, Case Temp.	-40°C to +85°C			
		Extended temperature operation is available, please contact the factory.			
ALTITUDE		ALL MODELS			
Operating	Standard Package	0 to 10,000 ft			
Storage	Standard Package	0 to 50,000 ft			
HUMIDITY		ALL MODELS			
Operating	Standard Package	0 to 95% non-condensing			
Storage	Standard Package	0 to 95% non-condensing			
PACKAGING		ALL MODELS			
Chassis Length	Not including mounting feet	18.5in (469.9mm)			
Chassis Width	Not including mounting feet	17.0in (431.8mm)			
Chassis Height	Not including mounting feet	5.0in (127.0mm)			
Front Panel Length	Not including handles or controls	19.0in (482.6mm)			
Front Panel Width	Not including handles or controls	0.125in (3.18mm)			
Front Panel Height	Not including handles or controls	5.25in (3U or 133.35mm)			
Weight	Overall (configuration dependent)	~ 30 lbs (11.2kg)			
Weight	Shipping (configuration dependent)	~ 40 lbs (14.93kg)			

Specifications subject to change without notice.



Making High Voltage Easier!®

Higher Service, Higher Performance, Higher Reliability

©2011, UltraVolt Inc. All rights reserved.

# HV RACK® CONFIGURABLE SERIES

Rack Mount High Voltage Power System

FIGURE A:

## HV Rack Configurable System Block Diagram

Rev. B 9/30/06

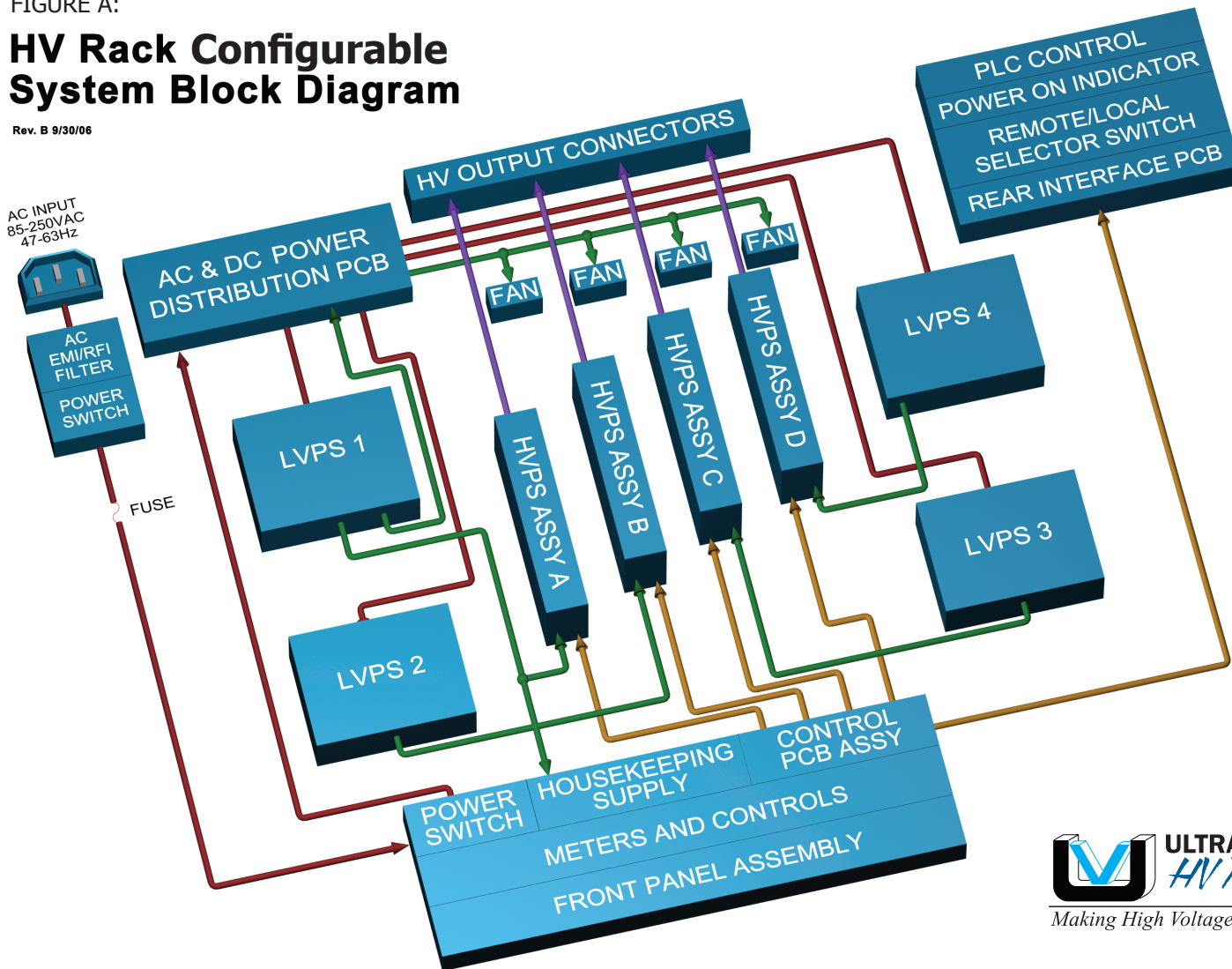
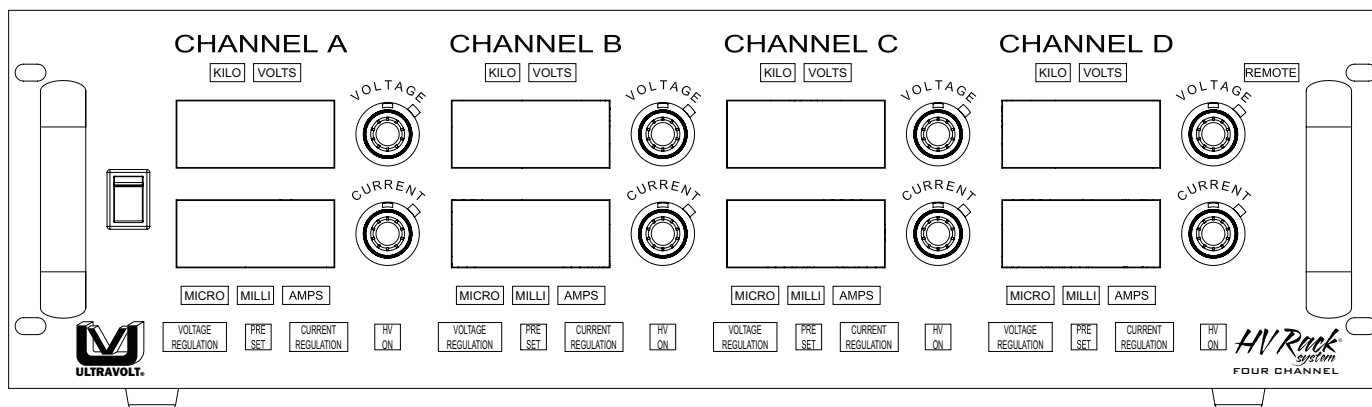

FIGURE B: FRONT PANEL



Making High Voltage Easier!®

1800 Ocean Avenue, Ronkonkoma, NY 11779  
 Phone: 1-631-471-4444 Fax: 1-631-471-4696 www.ultravolt.com

# HV RACK® CONFIGURABLE SERIES

## Rack Mount High Voltage Power System

FIGURE C: REAR PANEL (EXAMPLE)

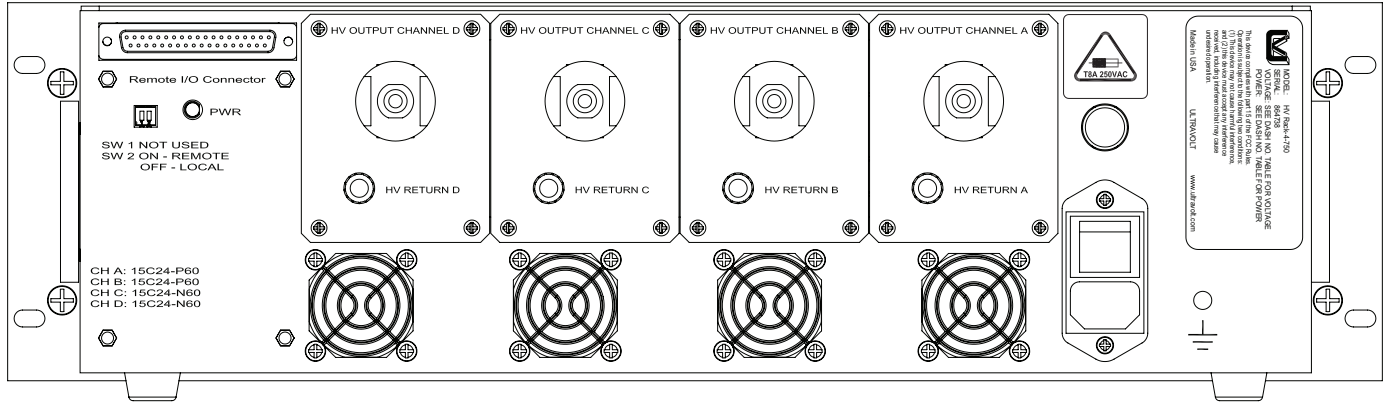

STANDARD HV CONNECTOR:

- Alden B110YX10 (one per channel)

CURRENTLY AVAILABLE OPTIONS:

- USB Interface (USB-HV-RACK)
- Floating/Isolated Channels
- SHV Connectors
- Amp Connectors
- Fischer Connectors
- Alden Connectors
- Caton Connectors
- Parker Medical Connectors
- Removable Mounting Feet
- Mounting Slides

Manufactured in USA

ORDERING INFORMATION	
TYPE:	DESCRIPTION:
HV-RACK-1-250	19" HV Rack with (1) set of meters & controls with 300 watts of LV power configured for: One channel 250W max total output.
HV-RACK-1-500	19" HV Rack with (1) set of meters & controls with 600 watts of LV power configured for: One channel 500W max total output.
HV-RACK-1-750	19" HV Rack with (1) set of meters & controls with 900 watts of LV power configured for: One channel 750W max total output.
HV-RACK-1-1000	19" HV Rack with (1) set of meters & controls with 1200 watts of LV power configured for: One channel 1000W max total output.
HV-RACK-2-250	19" HV Rack with (2) sets of meters & controls with 300 watts of LV power configured for: Two channels 250W max combined output.
HV-RACK-2-500	19" HV Rack with (2) sets of meters & controls with 600 watts of LV power configured for: Two channels 500W max combined output.
HV-RACK-2-750	19" HV Rack with (2) sets of meters & controls with 900 watts of LV power configured for: Two channels 750W max combined output.
HV-RACK-2-1000	19" HV Rack with (2) sets of meters & controls with 1200 watts of LV power configured for: Two channels 1000W max combined output.
HV-RACK-3-250	19" HV Rack with (3) sets of meters & controls with 300 watts of LV power configured for: Three channels 250W max combined output.
HV-RACK-3-500	19" HV Rack with (3) sets of meters & controls with 600 watts of LV power configured for: Three channels 500W max combined output.
HV-RACK-3-750	19" HV Rack with (3) sets of meters & controls with 900 watts of LV power configured for: Three channels 750W max combined output.
HV-RACK-3-1000	19" HV Rack with (3) sets of meters & controls with 1200 watts of LV power configured for: Three channels 1000W max combined output.
HV-RACK-4-250	19" HV Rack with (4) sets of meters & controls with 300 watts of LV power configured for: Four channels 250W max combined output.
HV-RACK-4-500	19" HV Rack with (4) sets of meters & controls with 600 watts of LV power configured for: Four channels 500W max combined output.
HV-RACK-4-750	19" HV Rack with (4) sets of meters & controls with 900 watts of LV power configured for: Four channels 750W max combined output.
HV-RACK-4-1000	19" HV Rack with (4) sets of meters & controls with 1200 watts of LV power configured for: Four channels 1000W max combined output.

Note: The sum of the output power capability of the modules cannot exceed the total rack power capability. Please contact the factory to configure your HV Rack part number.

Exceeding 250W in a single channel is possible by paralleling UltraVolt's High Power C Series of 250W models.

Rev. M 10/14



Making High Voltage Easier!®

1800 Ocean Avenue, Ronkonkoma, NY 11779  
 Phone: 1-631-471-4444 Fax: 1-631-471-4696 www.ultravolt.com

# HCP SERIES

## High Voltage Power System



The HCP Series of high-voltage rack mount and bench-top power systems is a fully-featured chassis that enables users to reach higher levels of power, up to 15kW. The broad range of voltage and power levels make the HCP Series suitable for a broad range of industries and applications. Users will also benefit from the high performance of the system, which includes low ripple, excellent regulation, and a low stored energy.

- Voltage ranges from 0 to 3.5kV through 300kV
- Output power from 0 to 12W up to 15kW
- ½19" rack mount, 19" rack mount, or bench-top case

Applications for the HCP Series include photomultipliers, particle accelerators, ion implantation, ion sources, ion pumps, electrostatics, test equipment and more.

- Efficiency at 90%
- Fully programmable by 10-turn potentiometer
- Voltage and current monitors on all models
- Multiple computer interfaces available

PARAMETER	CONDITIONS	MODELS		UNITS																											
<b>INPUT</b>		<b>12W to 1200W</b>										<b>2000W to 15kW</b>																			
Voltage Range	Full Power	Single phase 115 or 230										Three phase 400 (360-440)										VAC									
Frequency	All Modes	47 to 63																				Hz									
<b>OUTPUT (3500V-6500V)</b>		<b>3500V</b>										<b>6500V</b>																			
Voltage Range	Nominal Input	0 to 3500										0 to 6500										VDC									
Power	Nominal Input, Max Eout	12	30	120	300	600	1200	2400	5000	10,000	15,000	12	30	120	300	600	1200	2400	5000	10,000	15,000	W									
Current	out Entire Output Voltage Range	4	10	40	100	200	400	800	1500	3000	4500	2	5	20	50	100	200	400	750	1500	2300	mA									
Weight		3	4	6	7	11	13	25	40	75	110	3	4	6	7	11	13	25	40	75	110	kg									
<b>OUTPUT (12,500V-20,000V)</b>		<b>12,500V</b>										<b>20,000V</b>																			
Voltage Range	Nominal Input	0 to 12,500										0 to 20,000										VDC									
Power	Nominal Input, Max Eout	12	30	120	300	600	1200	2400	5000	10,000	15,000	12	30	120	300	600	1200	2400	4000	W											
Current	out Entire Output Voltage Range	1	2.5	10	25	50	100	200	400	800	1200	0.6	1.5	6	15	30	60	120	200	mA											
Weight		4	5	7	11	16	21	35	40	75	110	4	5	7	11	16	21	35	45	kg											
<b>OUTPUT (35,000V-300,000V)</b>		<b>35,000V</b>					<b>65,000V</b>					<b>100,000V</b>				<b>150,000V</b>				<b>200,000V</b>				<b>300,000V</b>							
Voltage Range	Nominal Input	0 to 35,000					0 to 65,000					0 to 100,000				0 to 150,000				0 to 200,000				0 to 300,000				VDC			
Power	Nominal Input, Max Eout	30	120	300	600	1200	2400	4000	30	120	300	600	1200	2400	100	300	600	1200	75	300	600	1200	120	300	600	1200	75	300	600	1200	W
Current	out Entire Output Voltage Range	1	4	10	20	40	80	120	0.5	2	5	10	20	40	1	3	6	12	0.5	2	4	8	0.75	1.5	3	6	0.3	1	2	4	mA
Weight		10	12	17	20	25	45	50	17	21	45	55	70	80	50	55	73	90	110	130	140	160	160	180	200	220	180	200	220	250	kg
<b>OUTPUT</b>		<b>ALL TYPES</b>																													
Ripple	Full Load, Max Eout	100ppm + 50																				mV p-p									
Programming Accuracy	0.1% to 100% Output Voltage	0.01%																				-									
Dynamic Load Regulation	½ to Full Load, Max Eout	200																				PPM									
Line Regulation	Nom. Input, Max Eout, Full Power	10																				PPM									
Static Load Regulation	No Load to Full Load, Max Eout	100																				PPM									
Stability	30 Min. warmup, per 8 hr/ per day	150																				PPM									
<b>PROGRAMMING &amp; CONTROLS</b>		<b>ALL TYPES</b>																													
Output Control & Monitoring		Front panel and/or optional Analog 0 to +10 standard & isolated / Digital 12 bit: RS-232, RS-422, Ethernet, USB, LAN																				-									
<b>ENVIRONMENTAL</b>		<b>ALL TYPES</b>																													
Operating	Full Load, Max Eout, Case Temp.	0 to +40																				°C									
Storage	Non-Operating, Case Temp.	-20 to +60																				°C									
Humidity	All Conditions, Standard Package	80% @ 30C; 50% @ 40C																				-									
Shock	Mil-Std-810, Method 516.5, Proc. IV	< 20																				G's									
Vibration	Mil-Std-810, Method 514.5, Fig.514.5C-3	TBD																				-									

Specifications subject to change without notice.



Making High Voltage Easier!®

Higher Service, Higher Performance, Higher Reliability  
©2012, UltraVolt Inc. All rights reserved..

# HCP SERIES

## High Voltage Power System

### CONSTRUCTION

TBD

### TOLERANCE

TBD

### NOTES

For 6.5kV/2400W, models will be 2U higher with polarity reversal switch. For 3.5kV/2400W and 65kV (all power levels), models will be 2U higher and 100mm deeper with the polarity reversal switch. For outline drawings of the HCP Series chassis, please contact the factory.

### SIZE

	3.5kV	6.5kV	12.5kV	20kV	35kV	65kV	100kV	150kV	200kV	300kV
12W	3U-A	3U-A	3U-A	3U-A						
30W	3U-A	3U-A	3U-A	3U-A	3U-D	3U-D				
75W								10U		29U
100W							5U			
120W	3U-A	3U-A	3U-A	3U-A	3U-D	3U-D			12U-B	
300W	3U-B	3U-B	3U-D	3U-D	3U-D	6U-A	5U	10U	29U	38U-A
600W	3U-C	3U-C	3U-E	3U-E	3U-E	8U	8U	10U	38U-B	38U-B
1.2kW	3U-D	3U-D	3U-F	3U-F	3U-F	9U-A	9U-A	12U-B	38U-B	38U-B
2.4kW	3U-E	3U-F	6U-B	6U-C	6U-C	9U-A				
4kW				6U-C	7U					
5kW	6U-C	6U-C	6U-C							
10kW	9U-B	9U-B	9U-B							
15kW	12U-A	12U-A								

3U-A	½ 19" [222mm] x 3U [133mm] x 13.78" [350mm]	3U-B	½ 19" [222mm] x 3U [133mm] x 17.72" [450mm]	3U-C	19" [443mm] x 3U [133mm] x 13.78" [350mm]
3U-D	19" [443mm] x 3U [133mm] x 17.72" [450mm]	3U-E	19" [443mm] x 3U [133mm] x 21.65" [550mm]	3U-F	19" [443mm] x 3U [133mm] x 25.59" [650mm]
5U	19" [443mm] x 5U [221mm] x 21.65" [550mm]				
6U-A	19" [443mm] x 6U [266mm] x 17.72" [450mm]	6U-B	19" [443mm] x 6U [266mm] x 21.65" [550mm]	6U-C	19" [443mm] x 6U [266mm] x 25.59" [650mm]
7U	19" [443mm] x 7U [310mm] x 25.59" [650mm]				
8U	19" [443mm] x 8U [355mm] x 21.65" [550mm]				
9U-A	19" [443mm] x 9U [399mm] x 21.65" [550mm]	9U-B	19" [443mm] x 9U [399mm] x 25.59" [650mm]		
10U	19" [443mm] x 10U [433mm] x 29.53" [750mm]				
12U-A	19" [443mm] x 12U [535mm] x 25.59" [650mm]	12U-B	19" [443mm] x 12U [535mm] x 29.53" [750mm]		
29U	23.62" [600mm] x 29U [1500mm] x 29.53" [750mm]				
38U-A	23.62" [600mm] x 38U [2000mm] x 23.62" [600mm]	38U-B	23.62" [600mm] x 38U [2000mm] x 31.50" [800mm]		



*Making High Voltage Easier!®*

1800 Ocean Avenue, Ronkonkoma, NY 11779  
 Phone: 1-631-471-4444 Fax: 1-631-471-4696 www.ultravolt.com



# HCP SERIES

## High Voltage Power System

### ORDERING INFORMATION

Output	0 to 3.5kV Output	3.5
	0 to 6.5kV Output	6.5
	0 to 12.5kV Output	12.5
	0 to 20kV Output	20
	0 to 35kV Output	35
	0 to 65kV Output	65
	0 to 100kV Output	100
	0 to 150kV Output	150
	0 to 200kV Output	200
	0 to 300kV Output	300
Model	Series Name	HCP
Input	115V (12W to 1200W models only)	115
	230V (12W to 1200W models only)	230
	400V 3 Phase(2000W to 15kW models only)	400
Polarity	Positive Output	-P
	Negative Output	-N
Power	0 to 12W Output (3.5kV to 20kV models only)	12
	0 to 30W Output (3.5kV to 65kV models only)	30
	0 to 75W Output (150kV & 300kV models only)	75
	0 to 100W Output (100kV models only)	100
	0 to 120W Output (3.5kV to 65kV, 200kV models only)	120
	0 to 300W Output	300
	0 to 600W Output	600
	0 to 1.2kW Output	1.2kW
	0 to 2.4kW Output (3.5kV to 65kV models only)	2.4kW
	0 to 4kW Output (20kV & 30kV models only)	4kW
	0 to 5kW Output (3.5kV to 12.5kV models only)	5kW
0 to 10kW Output (3.5kV to 12.5kV models only)	10kW	
0 to 15kW Output (3.5kV to 12.5kV models only)	15kW	
Options	Rear panel RS232 interface	-RS232
	Rear panel RS422 interface	-RS422
	Rear panel Ethernet interface	-ETH
	Rear panel USB interface	-USB
	Rear panel LAN interface	-LAN
	Fine adjust potentiometer	-FA
	Analog interface 0 to 10VDC control & monitors	-I10
	Floating analog interface 0 to 10VDC control & monitors	-I10I
	Floating HV Retrun ±300	-FL
	Lower ripple	-F
	Higher stability	-10PPM
	Low stored energy	-LSE
	Power limit	-CP
Rackmount	-RACK	

High resolution meters available. Contact the factory for more information.

Example: **3.5HCP115-P2.4kW-USB**

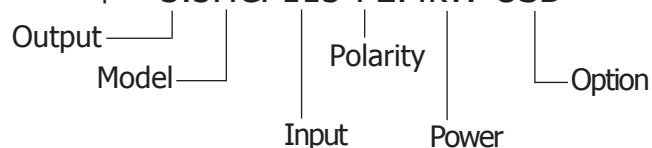

Rev. C 06/13

\*The HCP Series is not available in all territories. Please contact an UltraVolt Applications Engineer for details concerning sales in your area.



*Making High Voltage Easier!®*

1800 Ocean Avenue, Ronkonkoma, NY 11779  
Phone: 1-631-471-4444 Fax: 1-631-471-4696 www.ultravolt.com

# MCP SERIES

## Floating Output High Voltage Power System



The MCP Series of high-voltage rack mount and bench-top power systems is a fully-featured chassis that enables users to reach higher levels of power, up to 15kW. The broad range of voltage and power levels make the MCP Series suitable for a broad range of industries and applications. Users will also benefit from the high performance of the system, which includes low ripple, excellent regulation, floating output, and a low stored energy.

Applications for the MCP Series include photomultipliers, particle accelerators, ion implantation, ion sources, ion pumps, electrostatics, test equipment and more.

- Floating output voltage up to 2kV
- Output power from 0 to 12W up to 15kW
- ½19" rack mount, 19" rack mount, or bench-top case
- Efficiency at 90%

- Fully programmable by 10-turn potentiometer
- Voltage and current monitors on all models
- Multiple computer interfaces available

PARAMETER	CONDITIONS	MODELS																		UNITS		
<b>INPUT</b>		12W to 1200W									2000W to 15kW											
Voltage Range	Full Power	Single phase 115 or 230									Three phase 400 (360-440)									VAC		
Frequency	All Modes	47 to 63																		Hz		
<b>OUTPUT (125V-200V)</b>		125V									200V											
Voltage Range	Nominal Input	0 to 125									0 to 200									VDC		
Power	Nominal Input, Max Eout	30	120	300	600	1200	2400	5000	10000	15000	30	120	300	600	1200	2400	5000	10000	15000	W		
Current	out Entire Output Voltage Range	0.25	1	2.5	5	10	20	40	80	120	0.15	0.6	1.5	3	6	15	25	50	75	A		
<b>OUTPUT (350V-650V)</b>		350V									650V											
Voltage Range	Nominal Input	0 to 350									0 to 650									VDC		
Power	Nominal Input, Max Eout	30	120	300	600	1200	2400	5000	10000	15000	12	30	120	300	600	1200	2400	4500	10000	15000	W	
Current	out Entire Output Voltage Range	0.1	0.4	1	2	4	8	14	28	42	0.02	0.05	0.2	0.5	1	2	4	7	15	22.5	A	
<b>OUTPUT (1250V-2000V)</b>		1250V									2000V											
Voltage Range	Nominal Input	0 to 1250									0 to 2000									VDC		
Power	Nominal Input, Max Eout	12	30	120	300	600	1200	2400	5000	10000	15000	12	30	120	300	600	1200	2000	5000	10000	14000	W
Current	out Entire Output Voltage Range	0.01	0.025	0.1	0.25	0.5	1	2	4	8	12	0.006	0.015	0.06	0.15	0.3	0.6	1	2.5	5	7	A
<b>OUTPUT</b>		<b>ALL TYPES</b>																				
Isolation	Input to Output	12V to 350V: ±500; 650V to 2kV: ±2000																		VDC		
Ripple	Full Load, Max Eout	12W to 300W: 50ppm + 50; 600W to 15kW: 200ppm +200																		mV p-p		
Programming Accuracy	0.1% to 100% Output Voltage	0.001%																		-		
Dynamic Load Regulation	½ to Full Load, Max Eout	100																		PPM		
Line Regulation	Nom. Input, Max Eout, Full Power	10																		PPM		
Static Load Regulation	No Load to Full Load, Max Eout	100																		PPM		
Stability	30 Min. warmup, per 8 hr/ per day	100																		PPM		
<b>PROGRAMMING &amp; CONTROLS</b>		<b>ALL TYPES</b>																				
Output Control & Monitoring		Front panel and/or optional Analog 0 to +10 standard & isolated / Digital 12 bit: RS-232, RS-422, Ethernet, USB, LAN																		-		
<b>ENVIRONMENTAL</b>		<b>ALL TYPES</b>																				
Operating	Full Load, Max Eout, Case Temp.	0 to +40																		°C		
Storage	Non-Operating, Case Temp.	-20 to +60																		°C		
Humidity	All Conditions, Standard Package	80% @ 30C; 50% @ 40C																		-		
Shock	Mil-Std-810, Method 516.5, Proc. IV	< 20																		G's		
Vibration	Mil-Std-810, Method 514.5, Fig.514.5C-3	TBD																		-		

Specifications subject to change without notice.



Making High Voltage Easier!®

Higher Service, Higher Performance, Higher Reliability

©2012, UltraVolt Inc. All rights reserved..

# MCP SERIES

## Floating Output High Voltage Power System

### CONSTRUCTION

TBD

### SIZE

Dimensions:

0 to 300W models:

½19" [222mm] W x 3U [133mm] H x 13.78" [350mm] depth

600W models:

19" [443mm] W x 3U [133mm] x 13.78" [350mm] depth

1200W models:

19" [443mm] W x 3U [133mm] x 17.72" [450mm] depth

2000W and 2400W models:

19" [443mm] W x 3U [133mm] x 21.65" [550mm] depth

4500W and 5000W models:

19" [443mm] W x 6U [266mm] x 25.59" [650mm] depth

10kW models:

19" [443mm] W x 9U [399mm] x 25.59" [650mm] depth

14kW and 15kW models:

19" [443mm] W x 12U [532mm] x 25.59" [650mm] depth

Weight:

12W & 30W models: 8.82lbs [4kg]

120W models: 11.02lbs [5kg]

300W models: 13.23lbs [6kg]

600W models: 19.84lbs [9kg]

1200W and 2000W models: 26.46lbs [12kg]

2400W models: 50.71lbs [23kg]

4500W and 5000W models: 88.18lbs [40kg]

10kW models: 165.35lbs [75kg]

14kW and 15kW models: 242.51lbs [110kg]

### TOLERANCE

TBD

### NOTES

For outline drawings of the MCP Series chassis, please contact the factory.

### ORDERING INFORMATION

Output	0 to 125V Output	0.125
	0 to 200V Output	0.2
	0 to 350V Output	0.35
	0 to 650V Output	0.65
	0 to 1250V Output	1.25
	0 to 2000V Output	2
Model	Series Name	MCP
Input	115V (12W to 1200W models only)	115
	230V (12W to 1200W models only)	230
	400V 3 Phase(2000W to 15kW models only)	400
Polarity	Positive Output	-P
	Negative Output	-N
	Floating Output (Isolation voltage up to ±300VDC)	-FL
Power	0 to 12W Output (650V to 2kV models only)	12
	0 to 30W Output	30
	0 to 120W Output	120
	0 to 300W Output	300
	0 to 600W Output	600
	0 to 1.2kW Output	1.2kW
	0 to 2kW Output (2kV models only)	2kW
	0 to 2.4kW Output (Not available on 2kV models)	2.4kW
	0 to 4.5kW Output (650V models only)	4.5kW
	0 to 5kW Output (Not available on 650V models)	5kW
	0 to 10kW Output	10kW
Options	0 to 14kW Output (2kV models only)	14kW
	0 to 15kW Output (Not available on 2kV models)	15kW
	Rear panel RS232 interface	-RS232
	Rear panel RS422 interface	-RS422
	Rear panel Ethernet interface	-ETH
	Rear panel USB interface	-USB
	Rear panel LAN interface	-LAN
	Fine adjust potentiometer	-FA
	Analog interface 0 to 10VDC control & monitors	-I10
	Floating analog interface 0 to 10VDC control & monitors	-I10I
	Lower ripple	-F
Higher stability	-10PPM	
Low stored energy	-LSE	
Power limit	-CP	
Rackmount	-RACK	

High resolution meters available. Contact the factory for more information.

Example: 1.25MCP115-FL2.4kW-USB

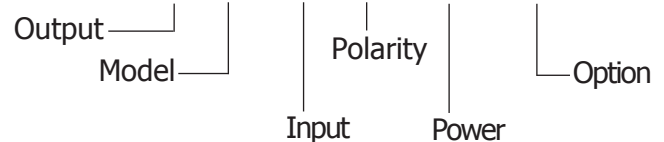

Rev. A 06/12

\*The MCP Series is not available in all territories. Please contact an UltraVolt Applications Engineer for details concerning sales in your area.



*Making High Voltage Easier!®*

1800 Ocean Avenue, Ronkonkoma, NY 11779  
Phone: 1-631-471-4444 Fax: 1-631-471-4696 www.ultravolt.com

# HCE SERIES

## High Voltage Cassette Power Supply



The HCE Series of high-voltage regulated AC-DC converters addresses the need for plug in HV modules that allow the system designer to build out a rack chassis as need. The modules are AC line operated fully integrated plug in HV modules with full features for local/remote analog controls & monitoring at good performance. Designed and built utilizing state-of-the-art power-conversion topology, these units feature design, manufacturing process, and encapsulation techniques that provide high reliability.

Typical applications for this series include the following:

**Capital Equipment Designers** can select multiple modules to create sub-systems to operate process control, manufacturing, test & measurement, and analysis machines for operating detectors, emitters, electrostatics, and actuators.

**R&D system designers** can select multiple modules to develop experiments, proof-of-concept equipment, and one-of-a-kind devices.

- 11 models provide fixed outputs of 0 to 125V through 35kV
- 0 to 7, 35, 140 or 350 watts of output power
- Input of 115VAC or 230VAC
- Compatible with Euro cassette rack & 19" rack chassis
- Indefinite output short-circuit protection & arc protection
- Remote control & monitors:
  - Constant Voltage/Constant Current Control (CVCC)
  - Output Current & Voltage Monitors
  - Remote TTL Enable / Disable Control
- Front panel controls & monitors:
  - AC power switch, Local/Remote control switch
  - Screwdriver set Constant Voltage/Constant Current Controls (CVCC) with LED mode indicators
  - Output current & voltage monitor jacks with GND jack for meter

PARAMETER	CONDITIONS	MODELS																UNITS
<b>INPUT</b>																		
Voltage Range	Full Power	115								230								VAC
Frequency	All Modes	47 to 63																Hz
<b>OUTPUT (125V-650V)</b>		<b>125V</b>				<b>200V</b>				<b>350V</b>				<b>650V</b>				
Voltage Range	Nominal Input	0 to 125				0 to 200				0 to 350				0 to 650				VDC
Power	Nominal Input, Max Eout	7	35	140	350	7	35	140	350	7	35	140	350	7	35	140	350	W
Current	out Entire Output Voltage Range	50	250	1000	2500	30	150	600	1500	20	100	400	1000	10	50	200	500	mA
<b>OUTPUT (1.25KV-6.5KV)</b>		<b>1,250V</b>				<b>2,000V</b>				<b>3,500V</b>				<b>6,500V</b>				
Voltage Range	Nominal Input	0 to 1250				0 to 2000				0 to 3500				0 to 6500				VDC
Power	Nominal Input, Max Eout	7	35	140	350	7	35	140	350	7	35	140	350	7	35	140	350	W
Current	out Entire Output Voltage Range	5	25	100	250	3	15	60	150	2	10	40	100	1	5	20	50	mA
<b>OUTPUT (12.5KV-35KV)</b>		<b>12,500V</b>				<b>20,000V</b>				<b>35,000V</b>								
Voltage Range	Nominal Input	0 to 12500				0 to 20000				0 to 35000				VDC				
Power	Nominal Input, Max Eout	7	35	140	350	7	35	140	350	7	35	140	350	W				
Current	out Entire Output Voltage Range	0.5	2.5	10	25	0.3	1.5	6	15	0.2	1	4	10	mA				
<b>OUTPUT</b>		<b>ALL TYPES</b>																
Isolation	Input to Output	0V or $\pm 125$ with jumper removed																VDC
Ripple	Full Load, Max Eout	Typical ripple <0.01% + 50mV Pk-Pk																mV p-p
Programming Accuracy	0.1% to 100% Output Voltage	0.01%																Volts
Dynamic Load Regulation	½ to Full Load, Max Eout	100																PPM
Line Regulation	Nom. Input, Max Eout, Full Power	10																PPM
Static Load Regulation	No Load to Full Load, Max Eout	200																PPM
Stability	30 Min. warmup, per 8 hr/ per day	100																PPM
<b>PROGRAMMING &amp; CONTROLS</b>		<b>ALL TYPES</b>																
Output Control & Monitoring																		-
<b>ENVIRONMENTAL</b>		<b>ALL TYPES</b>																
Operating	Full Load, Max Eout, Case Temp.	0 to +40																°C
Temperature Coefficient	Over the Specified Temperature	100																PPM
Storage	Non-Operating, Case Temp.	-20 to +60																°C
Humidity	Non-Condensing	80% @ 30 °C; 50% @ 40 °C																-
Shock	Mil-Std-810, Method 516.5, Proc. IV	< 20																G's
Vibration	Mil-Std-810, Method 514.5, Fig.514.5C-3	TBD																-

Specifications subject to change without notice.



Making High Voltage Easier!®

Higher Service, Higher Performance, Higher Reliability

©2013, UltraVolt Inc. All rights reserved..



# HCE SERIES

## High Voltage Cassette Power Supply

### CONSTRUCTION

Aluminum

### SIZE

Dimensions:

7W @ 125-12500V models:

14U [71mm] W x 3U [133mm] H x [170mm] depth

7W @ 20000V models:

21U [107mm] W x 3U [133mm] H x [170mm] depth

7W @ 35000V models:

28U [142mm] W x 3U [133mm] H x [170mm] depth

35W @ 125-20000V models:

21U [107mm] W x 3U [133mm] x [170mm] depth

35W @ 35000V models:

28U [142mm] W x 3U [133mm] x [170mm] depth

140W @ 125-6500V models:

21U [107mm] W x 6U [262mm] x [230mm] depth

140W @ 12500-35000V models:

28U [142mm] W x 6U [262mm] x [230mm] depth

350W @ 125-2000V models:

21U [107mm] W x 6U [262mm] x [230mm] depth

350W @ 3500-35000V models:

28U [142mm] W x 6U [262mm] x [230mm] depth

Weight:

7W @ 125-3500V models: 2.65lbs [1.2kg]

7W @ 6500-12500V models: 2.87lbs [1.3kg]

7W @ 20000V models: 5.07lbs [2.3kg]

7W @ 35000V models: 5.51lbs [2.5kg]

35W @ 125-6500V models: 3.3lbs [1.5kg]

35W @ 12500V models: 3.97lbs [1.8kg]

35W @ 20000V models: 5.51lbs [2.5kg]

35W @ 35000V models: 6.17lbs [2.8kg]

140W @ 125-3500V models: 6.6lbs [3.0kg]

140W @ 6500-35000V models: 11.02lbs [5.0kg]

350W @ 125-3500V models: 8.82lbs [4.0kg]

350W @ 6500-35000V models: 13.23lbs [6.0kg]

### NOTES

From 1250 V nominal voltage on, HV-connectors are provided. The mating HV-connectors are delivered with the unit. HV mating connectors with cables are separate, please contact the factory for part numbers, standard cable lengths, optional cable lengths and cable terminations.

The "0V" - terminal of the output is connected to earth on the back panel but may be disconnected as needed. When disconnected, the "0V" (earthy) terminal may float with respect to earth up to  $\pm 125$  V.

See the HCE Tech Note for analog control connector information.

ORDERING INFORMATION		
Output	0 to 125V Output	125
	0 to 200V Output	200
	0 to 350V Output	350
	0 to 650V Output	650
	0 to 1250V Output	1250
	0 to 2000V Output	2000
	0 to 3500V Output	3500
	0 to 6500V Output	6500
	0 to 12500V Output	12500
	0 to 20000V Output	20000
	0 to 35000V Output	35000
Model	Series Name	HCE
Input	115 VAC	-115
	230 VAC	-230
Polarity	Postive Output	-P
	Negative Output	-N
Power	0 to 7W Output	7
	0 to 35W Output	35
	0 to 140W Output	140
	0 to 350W Output	350
Digital Ready Enhanced Interface	5V Controls and Monitors	-I5
	10V Controls and Monitors (24V in only)	-I10
Connectors	Terminals ( $\leq 650$ V)	STD
	SHV connector ( $> 1$ kVDC $< 6.5$ kV)	STD
	F 3415AG 6.2 ( $> 6.5$ kV $\leq 20$ kV)	STD
	F 3430AG 10.2 connector (35kV)	STD
Seperate Rack Chassis Available	19" Rack chassis for multiple modules	OPENRACK-19"
	Euro Rack chassis for multiple modules	OPENRACK-EURO
Chassis Options	Handles for the above open rack chassis	-HANDLES

High resolution meters available. Contact the factory for more information.

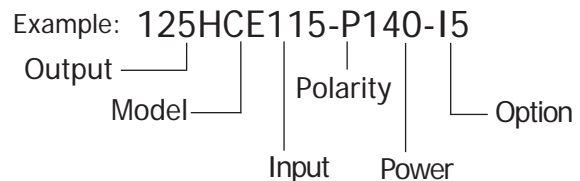

Rev. 1 3/13

\*The HCE Series is not available in all territories. Please contact an UltraVolt Applications Engineer for details concerning sales in your area.



*Making High Voltage Easier!®*

1800 Ocean Avenue, Ronkonkoma, NY 11779  
Phone: 1-631-471-4444 Fax: 1-631-471-4696 www.ultravolt.com

# HPV SERIES

## High Power High Voltage Power Supply



### PRELIMINARY DATASHEET

The HPV Series of High-Power / High-Voltage regulated AC to DC power supplies deliver high performance energy for higher reliability 24/7 applications & environments such as medical, industrial, manufacturing, agriculture, food processing, and research equipment. The HPV Series has high control speed, high accuracy, and high efficiency (85%) compared to other devices of this type.

- 7 Models from 0 to 60kV through 200kV
- 6 Models from 0 to 6kW through 60kW
- Single-output & multi-output configurations available
- E-Beam configurations with floating Wehnelt, filament, and surge outputs

Typical applications for this series include the following:

- **High-power electron beams** in industrial applications such as electron beam welding, coating, linking, and surface treatment.
- **High-power electron tubes** such as Triodes, Tetrodes, Klystrons, X-ray tubes.
- **High-power high voltage** for accelerators, ion beams, pulsed power, electrostatic precipitators, medical, and research equipment.

- Available with Voltage regulation, Current regulation, and Emission regulation
- No minimum load required
- Short-circuit protection & arc protection
- Low ripple option

PARAMETER	CONDITIONS	MODELS																								UNITS
<b>INPUT</b>																										
Voltage Range	Full Power	230VAC (Control Power) & 400VAC (Main Power) $\pm$ 10% (Other Inputs Available)																								VAC
Frequency	All Modes	47 to 63																								Hz
Current	Max Load, Max Eout	See Tech Note																								A
<b>OUTPUT (60kV-120kV)</b>		<b>60kV</b>						<b>80kV</b>						<b>100kV</b>						<b>120kV</b>						
Voltage Range	Nominal Input	0 to 60						0 to 80						0 to 100						0 to 120						kV
Power	Nominal Input, Max Eout	6	10	15	30	45	60	6	10	15	30	45	60	6	10	15	30	45	60	6	10	15	30	45	60	kW
Current	lout Entire Output Voltage Range	100	167	250	500	750	1000	75	125	188	375	563	750	60	100	150	300	450	600	48	80	120	240	360	480	mA
<b>OUTPUT (150kV-200kV)</b>		<b>150kV</b>						<b>175kV</b>						<b>200kV</b>												
Voltage Range	Nominal Input	0 to 150						0 to 175						0 to 200						kV						
Power	Nominal Input, Max Eout	6	10	15	30	45	60	6	10	15	30	45	60	6	10	15	30	45	60	kW						
Current	lout Entire Output Voltage Range	40	67	100	200	300	400	34	57	86	171	257	343	30	50	75	150	225	300	mA						
<b>ADDITIONAL OUTPUTS</b>																										
Filament	Floating on Main Output	10V @ 20A; 10V @ 40A; or 20V @ 10A																								
Wehnelt	Floating on Main Output	0 to 1.5kV @ 10mA; 0 to 2.5kV @ 10mA; or 0 to 3kV @ 10mA																								
Surge	Floating on Main Output	See Tech Note																								
<b>OUTPUT</b>		<b>ALL TYPES</b>																								
Ramp Up	0 to Max Voltage	2 Seconds (Others Available)																								
Ripple	Full Load, Max Eout	< 0.3%																								%V p-p
Programming Accuracy	10% to 100% Output Voltage	< 0.3%																								mV
Line Regulation	Nom. Input, Max Eout, Full Power	< 0.3%																								mV
Static Load Regulation	No Load to Full Load, Max Eout	< 0.3%																								mV
Stability	30 Min. warmup, per 8 hr/ per day	< 0.3%																								VDC
Static Current Regulation	Nom. Input, Max Eout, Full Power	< 0.3%																								mA
<b>ENVIRONMENTAL</b>		<b>ALL TYPES</b>																								
Operating	Full Load, Max Eout, Case Temp.	0 to 40																								°C
Humidity	All Conditions, Standard Package	0 to 80% non-condensing																								-

Specifications subject to change without notice.



Making High Voltage Easier!®

Higher Service, Higher Performance, Higher Reliability

©2013, UltraVolt Inc. All rights reserved..

# HPV SERIES

## High Power High Voltage Power Supply

### CONSTRUCTION

Power Coated Steel

### SIZE

Dimensions:

60-150kV at 6-15kW:

1000 L x 1200 W x 1600 H mm

60-80kV at 30-60kW:

1200 L x 1400 W x 1600 H mm

100-120kV at 30-60kW:

1200 L x 1500 W x 1800 H mm

150kV at 30-45kW:

1200 L x 1500 W x 1800 H mm

150kV at 60kW:

1300 L x 1600 W x 1800 H mm

175kV at 6-15kW:

1200 L x 1400 W x 1800 H mm

175kV at 30-45kW:

1300 L x 1700 W x 1900 H mm

175kV at 60kW:

1400 L x 1600 W x 1900 H mm

200kV at 6-15kW:

1400 L x 1600 W x 1900 H mm

200kV at 30-60kW:

1500 L x 1700 W x 2000 H mm

### TOLERANCE

TBD

### NOTES

**Various HV output configurations available:**

Single-output configuration, Multi-output configuration, E-Beam emission regulation via Wehnelt or filament, and capacitor charging for pulsed power.

**Control & monitoring:**

Main power control is separate from monitoring power to permit output monitoring with HV off. Features include AC main power keyswitch, HV on/off control, analog interface, interlock interface, 3 1/2 digit digital display of output voltage & current. LED Status indicators for Main Power, ARC, Overload, Interlock, Remote Control. Optional delayed arcing trip after a defined number of arcs. Optional digital interfaces available for LAN, USB, RS232.

**Cooling:**

Water cooling is standard, refrigerant cooling is optional.

**HV Output Cable:**

Include 5 meter HV-output cable pluggable - load side end open

For outline drawings of the HPV Series, please contact the factory.

ORDERING INFORMATION		
Output	60kV	60
	80kV	80
	100kV	100
	120kV	120
	150kV	150
	175kV	175
Model	Series Name	HPV
	Input	230VAC & 400VAC
Polarity	Positive	-P
	Negative	-N
Power	6kW	6kW
	10kW	10kW
	15kW	15kW
	30kW	30kW
	45kW	45kW
	60kW	60kW
Optional Additional Outputs	Filament 10VAC @ 20Amps	-FIL10-20
	Filament 10VAC @ 40Amps	-FIL10-40
	Filament 20VAC @ 10Amps	-FIL20-10
	Wehnelt 1500V @ 10mA	-WEH1.5
	Wehnelt 2500V @ 10mA	-WEH2.5
	Wehnelt 3000V @ 10mA	-WEH3.0
Other Options	Surge	-SURGE
	Emission Regulation by Wehnelt	-ERW
	Emission Regulation Filament	-ERF
	Constant Current Regulation	-CCR
	Ripple Stripper Output Filter	-F
	Delayed Arc Counter	-AQ
Optional Digital Interfaces	Refrigeration Cooling	-REF
	Rear panel RS232 interface	-RS232
	Rear panel USB interface	-USB
	Rear panel LAN interface	-LAN

Contact the factory for other output & control requirements!

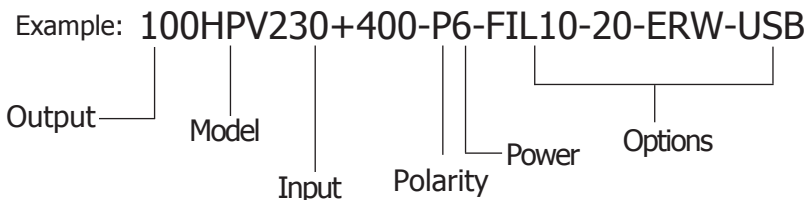

Rev. 4 11/13

\*The HPV Series is not available in all territories. Please contact an UltraVolt Applications Engineer for details concerning sales in your area.



Making High Voltage Easier!®

1800 Ocean Avenue, Ronkonkoma, NY 11779  
 Phone: 1-631-471-4444 Fax: 1-631-471-4696 www.ultravolt.com



# BT-GP SERIES

## General Purpose High Voltage Bench-top Power System

### PRELIMINARY DATASHEET

The compact, high-voltage BT-GP Series of general purpose bench-top high voltage power systems offers adjustable output voltage, digital voltage reading, highly stable output, and low ripple. BT-GP Series units are available in AC Input or DC input, positive or negative polarity, and with the option of one or two output connectors.

Applications for BT-GP Series high-voltage power systems include electrostatic, air purification, ATE, test equipment, process fluid cleaning, hi pot testing, and laboratory research.



- Available from 0 to 1kV through 0 to 30kV
- Up to 30W of output power
- 3.5 digit red LED output voltage display
- Bench-top configuration
- Single positive or negative output

- Ruggedized aluminum enclosure
- Enters constant current mode when fault occurs
- Highly portable with built in carrying handle (AC model)
- Protection against overload, short circuit, arc, and reverse polarity

PARAMETER	CONDITIONS	MODELS								UNITS
<b>INPUT</b>		<b>AC INPUT</b>				<b>DC INPUT</b>				
Voltage Range	Full Power	90-260 VAC				22-26 VDC				-
<b>OUTPUT</b>		<b>AC INPUT</b>				<b>DC INPUT</b>				
Voltage Range	Nominal Input	0 to 1,000	0 to 2,000	0 to 4,000	0 to 6,000	0 to 1,000	0 to 2,000	0 to 4,000	0 to 6,000	VDC
Power	Nominal Input, Max Eout	0 to 30				0 to 30				Watts
Current	Iout Entire Output Voltage Range	30	15	7.5	5	30	15	7.5	5	mA
Voltage Range	Nominal Input	0 to 10,000		0 to 20,000		0 to 30,000				VDC
Power	Nominal Input, Max Eout	0 to 30				0 to 30				Watts
Current	Iout Entire Output Voltage Range	3.0		1.5		1.0				mA
Ripple	Full Load, Max Eout	<0.01				<0.3				%V p-p
Line Regulation	Max-Min Input, Max Eout, Full Load	N/A				<0.3%				VDC
Load Regulation	No Load to Full Load, Max Eout	<0.5%				<0.01%				VDC
Stability	30 Min. warmup, per 8 hr/ per day	<0.05%				<0.1%				VDC
<b>PROGRAMMING &amp; CONTROLS</b>		<b>ALL TYPES</b>								
HV ON/OFF Controls		Front panel switch								-
<b>ENVIRONMENTAL</b>		<b>AC INPUT</b>				<b>DC INPUT</b>				
Coefficient	Over the Specified Temperature	100				200				PPM/°C
Storage Temperature	Non-Operating, Case Temp.	-20 to +60								°C
Operating Temperature	Full Load, Max Eout, Case Temp.	0 to +40								°C
Humidity	All Conditions, Standard Package	0 to 90% non-condensing								-

Specifications subject to change without notice.



Making High Voltage Easier!®

Higher Service, Higher Performance, Higher Reliability

©2011, UltraVolt Inc. All rights reserved.

# BT-GP SERIES

## General Purpose High Voltage Bench-top Power System

AC INPUT MODEL

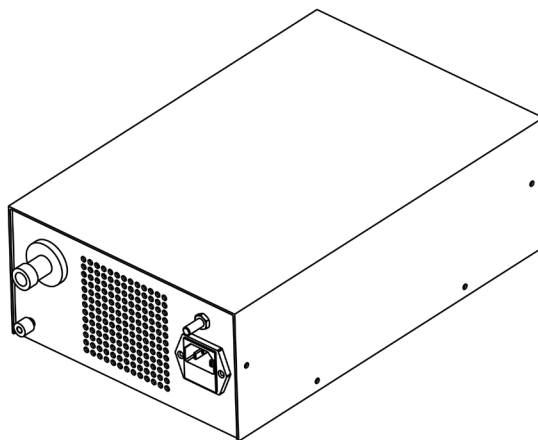
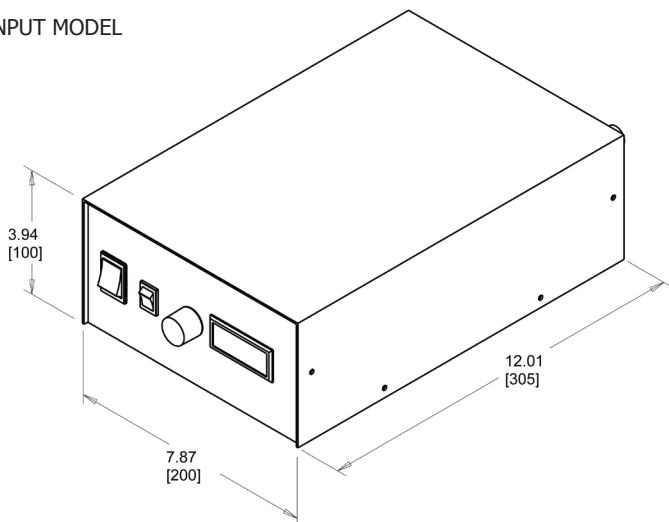

### CONSTRUCTION

Folded aluminum enclosure with blue paint finish

### SIZE

Dimensions:

AC Input: 12.01 L x 7.99 W x 4.33 H in (305.0 L x 203.0 W x 110.0 H mm)

DC Input: 11.81 L x 6.30 W x 3.94 H in (300.0 L x 160.0 W x 100.0 H mm)

Weight:

AC Input: 6.17lbs (2.8kg)

DC Input: 7.94lbs (3.6kg)

### NOTES

For the outline drawing on the DC Input model, or for additional outputs or power levels, please contact the factory.

#### ORDERING INFORMATION

Model	Series name	BT-GP
Input	90-264VAC input	-AC
	24VDC input	-24
Voltage	0 to 1kVDC output	-1
	0 to 2kVDC output	-2
	0 to 4kVDC output	-4
	0 to 6kVDC output	-6
	0 to 10kVDC output	-10
	0 to 20kVDC output	-20
	0 to 30kVDC output	-30
Polarity	Positive Output	P
	Negative Output	N
Power	Watts Output	30
Option	Mounting bars (AC model)	-MB
	Mounting bars (DC model)	(Standard)
	Remote HV ON/OFF (DC model)	-REM

Example: BT-GP-24-10P30-MB

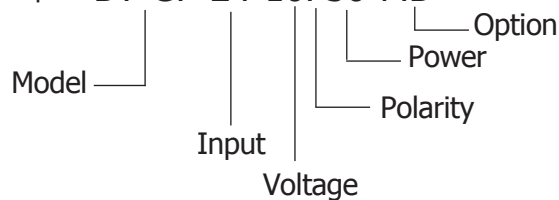

\*The BT-GP Series is not available in all territories. Please contact the factory for details concerning sales in your area.

Rev. B 4/13



Making High Voltage Easier!®

1800 Ocean Avenue, Ronkonkoma, NY 11779  
 Phone: 1-631-471-4444 Fax: 1-631-471-4696 www.ultravolt.com

# MMS-eB SERIES

## Multi-Module Solution - Electron Beam

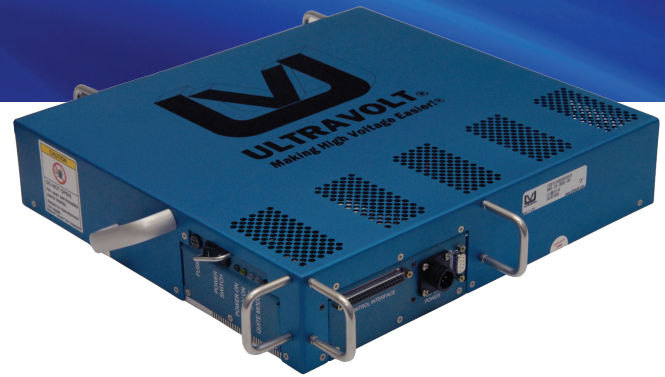

The multi-module solution - electron beam, or the MMS-eB Series, provides all the power sources needed to operate a variety of industry-standard precision electron guns. This highly advanced solution offers exceptional performance, including PPM level temperature coefficient, ripple, regulation, and stability. The MMS-eB Series is configurable as a 3-, 4-, or 5-bias electron gun high-voltage power supply for beam, filament, extractor, suppressor, and lens voltages. Users can specify which UltraVolt modules to place within the system, selecting from standard E Series and A-F Series power supplies.

- Optimal for electron guns
- Exceptional stability and ultra-low noise
- PPM level temp coefficient, ripple, regulation and stability
- Half-quiet and Full-quiet mode capability
- Wide variety of cables and connectors available
- <200ppm to <1ppm ripple
- <300ppm 3-year output stability
- Low common mode noise

PARAMETER	CONDITIONS	MODELS	UNITS
<b>INPUT</b>			
<b>ALL MODELS</b>			
Voltage Range	Full Power	24 ± 10%	VDC
Current	Full Load, Max Eout	≤3.5	A
<b>OUTPUT</b>			
<b>ALL MODELS</b>			
Accelerator		Any UltraVolt E Series or A Series power supply up to 15kV	-
Filament		Current regulated up to 3A with 0.1% accuracy and 10ppm temperature coefficient	-
Suppressor		Any A-F Series UltraVolt power supply up to 6kV	-
Extractor		Any standard E Series UltraVolt power supply	-
Lens		Any standard E Series UltraVolt power supply	-
<b>TEMPERATURE</b>			
<b>ALL MODELS</b>			
Operating	Full Load, Max Eout, Case Temp.	+18 to +40	°C
Storage	Non-Operating, Case Temp.	- 30 to +60	°C
<b>STABILITY</b>			
<b>ALL MODELS</b>			
Short term	30 Min. warmup, per 8 hr/ per day	<10	PPM/°C
Long term	Per week	<15	PPM/°C
Long term	3-year	<300	PPM/°C
<b>HUMIDITY</b>			
<b>ALL MODELS</b>			
Operating	Standard Package	25% to 70% (non-condensing)	-
Storage	Standard Package	0 to 95% (non-condensing)	-
<b>PACKAGING</b>			
<b>ALL MODELS</b>			
Chassis Length	Standard Package	14.4 (365)	in (mm)
Chassis Width	Standard Package	13.4 (340)	in (mm)
Chassis Height	Standard Package	3.0 (76)	in (mm)
Weight	Overall	<35	lbs

**Note:** Contact factory for detailed configuration specific datasheet.

Specifications subject to change without notice.



*Making High Voltage Easier!®*

**Higher Service, Higher Performance, Higher Reliability**

©2012, UltraVolt Inc. All rights reserved.

# MMS-eB SERIES

Multi-Module Solution - Electron Beam

MMS-eB BLOCK DIAGRAM

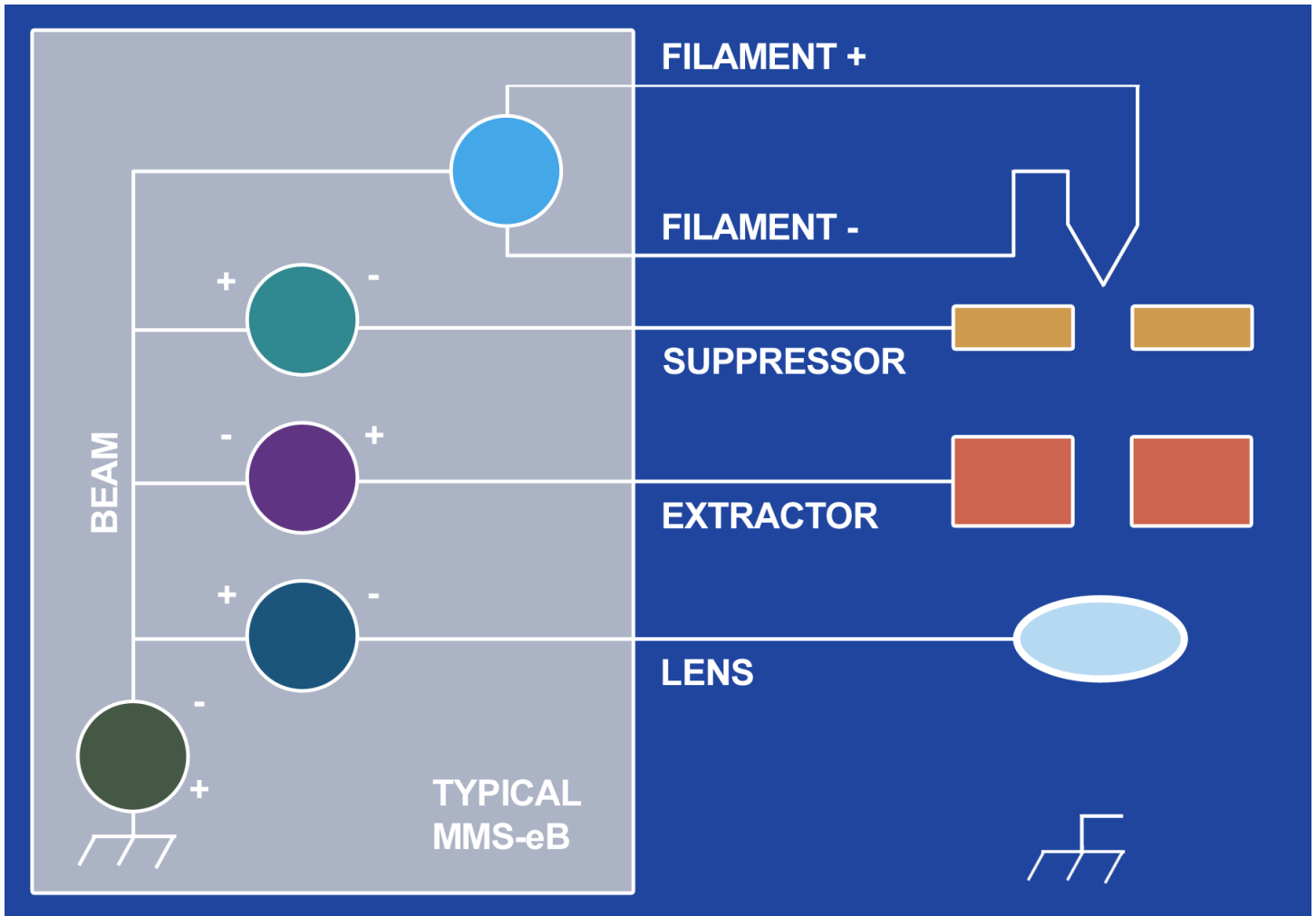

*Making High Voltage Easier!*<sup>®</sup>

1800 Ocean Avenue, Ronkonkoma, NY 11779  
Phone: 1-631-471-4444 Fax: 1-631-471-4696 [www.ultravolt.com](http://www.ultravolt.com)

# MMS-eB SERIES

Multi-Module Solution - Electron Beam

## STANDARD CASE

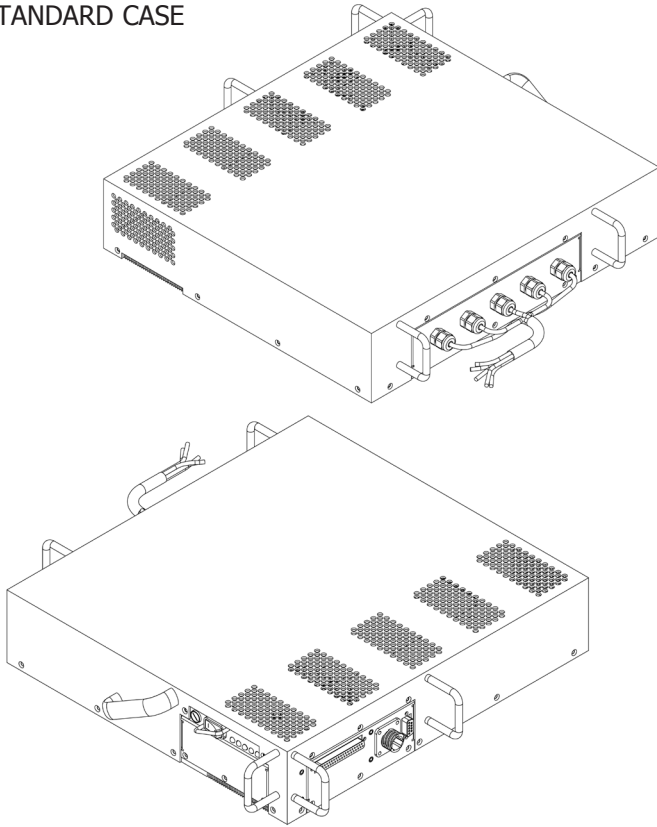

## SIZE

Dimensions: 14.4 in L (356mm) x 13.4 in (340mm) W x 3.0 in (76mm) H  
Weight: <35lbs

## NOTES

Output Connections:

HV Output:

- #1 - Filament A (+)
- #2 - Filament B (-)
- #3 - Suppressor
- #4 - Extractor
- #5 - Lens

HV Return: #8-32 x 0.250" (6.35mm) Blind Pem

Chassis Ground: #8-32 x 0.500" (12.7mm), through Stud

Contact the factory for outline drawings of the chassis.

## ORDERING INFORMATION

TYPE:	DESCRIPTION:
MMS-EB-*	Contact the factory for configuration specific part number.

Manufactured in USA

## CONNECTIONS

PIN	FUNCTION
1	Power Ground
2	Fused Power +5VDC Output (250mA)
3	Fused Power +5VDC Output (250mA)
4	Power Ground
5	Fused Power +15VDC Output (50mA)
6	Power Ground
7	Fused Power -15VDC Output (50mA)
8	Power Ground
9	Digital Ground
10	Quiet Mode CTRL Input (Standard=0, Quiet=1)
11	Quiet Mode Input (1/2 Quiet=0, Full Quiet=1)
12	MMS System Enable/Disable Output (Enable=1, Disable=0)
13	Monitor Select Bit (Iout=1, Eout=0)
14	Interlock Status Output (Good=1, Bad=0)
15	MMS System Status Output (Good=1, Bad=0)
16	Digital Ground
17	N/C
18	Temperature Monitor Output (Scaled to 100mV/°C)
19	+10V Reference Output
20	Signal Ground
21	Accelerator CTRL Input (0 to +10VDC = 0 to -15kV)
22	Accelerator Monitor Output (Monitor select bit Iout=1, Eout=0)
23	Signal Ground
24	Filament CTRL Input (0 to +10VDC = 0 to 3A)
25	Filament Monitor Output (Monitor select bit Iout=1, Eout=0)
26	Signal Ground
27	Suppressor CTRL Input (0 to +10VDC = 0 to -1000V)
28	Suppressor Monitor Output (Monitor select bit Iout=1, Eout=0)
29	Signal Ground
30	Extractor CTRL Input (0 to +10VDC = 0 to +15kV)
31	Extractor Monitor Output (Monitor select bit Iout=1, Eout=0)
32	Signal Ground
33	Lens CTRL Input (0 to +10VDC = 0 to +15kV)
34	Lens Monitor Output (Monitor select bit Iout=0, Eout=0)
35	N/C
36	N/C
37	N/C

# TF SERIES

## High Voltage Test Fixture

The TF Series product line is designed to support the need to make accurate measurements of high-voltage power supply (HVPS) & HV system performance. These reduced-size HV test fixture devices can be used for research and development, incoming inspection, production testing, field testing, or calibration. Each TF Series device, when coupled with a conventional meter or oscilloscope, is a stand-alone test fixture optimized for a specific HV testing function. The TF Series is engineered to support accurate measurement of ripple, noise, pulses, absolute DC, DC stability, DC line regulation, DC load regulation, etc.

- Make accurate HV in-line measurements
- View and measure AC ripple & noise on DC HV
- Measure absolute HV DC to 0.25% @ 25 PPM stability
- View and measure  $T_{rise}$ ,  $T_{fall}$ , overshoot & settling time
- Measure & monitor signals from 35Hz to 10MHz
- View signals from DC to 20MHz
- View and measure AC mV on DC kV
- PLC Analog/Digital Remote operation capability

### KEY FEATURES:

The UltraVolt TF Series models all feature dual Alden B110YX10 HV connectors. These connectors facilitate in-line measurements as well as un-terminated measurements. Internal ARC limiting / softening resistors are present for safety. All TF models have the HV ground return connection isolated from the chassis ground connection by 100k $\Omega$  and clamped by a protection device.

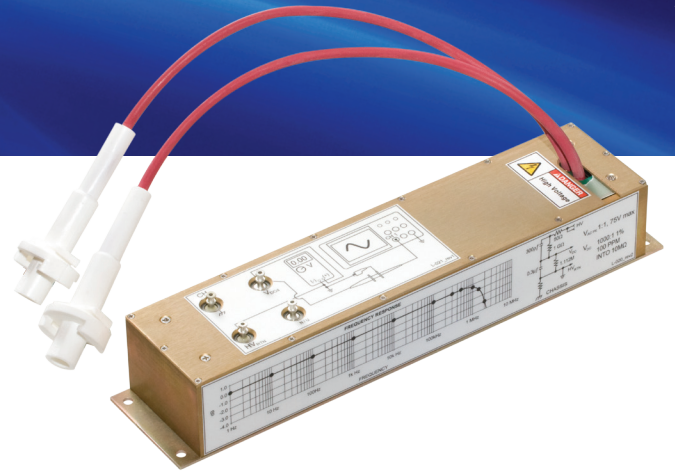

### SPECIFICATIONS:

All specifications are subject to change without notice. UltraVolt will enhance specifications whenever possible, through continuous product and process improvement efforts. Customers are not contacted when changes are made unless they have arranged for configuration control with UltraVolt's customer service department ("CSD") through the "-Q" suffix program. Only the most significant items will be noted on UltraVolt's web site, in the product change notice section.

### ALTITUDE, HUMIDITY & TEMPERATURE:

The TF Series operating performance is guaranteed between sea level and 10,000ft., in non-condensing relative humidity up to 95%, and between temperatures of -40°C to +65°C. Storage temperature range is -55°C to +105°C.

### TF SERIES MODELS:

#### "Precision Divider": 40TF-DCD

A 40kV rated HV Test Fixture that features a precision 10,000:1 DC divider ("DCD") with a full scale accuracy of  $\pm 1\%$ , a temperature stability of better than  $\pm 25$  ppm per  $^{\circ}\text{C}$ , and a voltage coefficient of  $< 1\%$  per 40,000 volts. DC Loading is 1 Gig $\Omega$ . Capacitive loading is  $< 10$  pF.

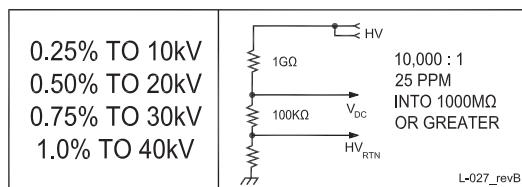

Fig. A - Accuracy & Equivalent Circuit (Precision Divider)

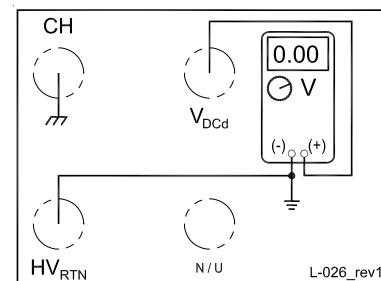

Fig. B - Electrical Connections (Precision Divider)

**⚠ WARNING! A shock hazard exists when the chassis ground or the HV return ground is not properly connected! ⚠**

Specifications subject to change without notice.



Making High Voltage Easier!®

Higher Service, Higher Performance, Higher Reliability

©2011, UltraVolt Inc. All rights reserved.

# TF SERIES

## High Voltage Test Fixture

### “Ripple & Voltage Monitor”: 40TF-ACV&DCD

A 40kV rated HV Test Fixture that features a 1:1 AC viewing (ACV) capacitor ( $V_{AC}=95\%$  of  $V_{AC}$  input  $\pm 5\%$ ) providing a bandwidth of 35Hz to 10MHz (Monitor 10Hz to 20MHz) over a signal range of 1mV to 75V Pk, along with a 1,000:1 DC divider (“DCD”) with a full scale accuracy of  $\pm 2\%$  and a temperature stability of better than  $\pm 100$  ppm per  $^{\circ}\text{C}$ . DC Loading is 2 Gig $\Omega$ . Capacitive loading is  $< 50\text{pF}$ .

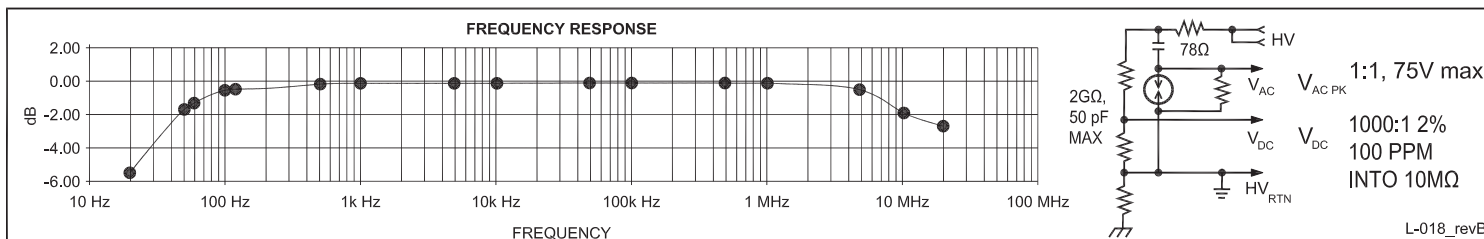

Note: It is recommended that the oscilloscope be set for 20MHz BW limit.  
Fig. C - Bandwidth & Equivalent Circuit (Ripple & Voltage Monitor)

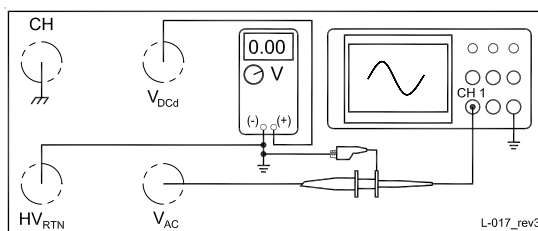
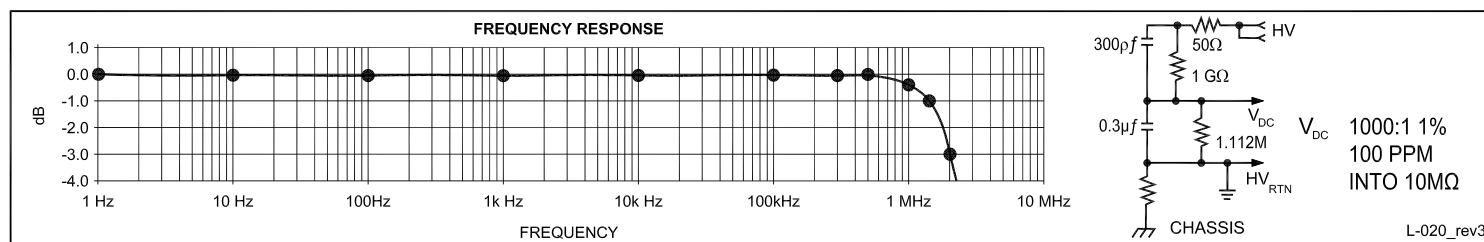

Fig. D - Electrical Connections (Ripple & Voltage Monitor)

**⚠ WARNING! A shock hazard exists when the chassis ground or the HV return ground is not properly connected! ⚠**

### “Compensated Divider”: 40TF-CDCD&CLOAD

A 40kV rated HV Test Fixture that features a compensated 1,000:1 Compensated DC Divider (“CDCD”) capable of showing  $T_{rise}$ ,  $T_{fall}$ , overshoot & settling over a bandwidth of DC to 2MHz. The unit also functions as a 300pF capacitive load (“CLOAD”). DC Loading is 1 Gig $\Omega$ . DC full-scale accuracy is  $\pm 2\%$  with temperature stability of better than  $\pm 100$  ppm per  $^{\circ}\text{C}$ .



Note: It is recommended that the oscilloscope be set for 20MHz BW limit.  
Fig. E - Bandwidth & Equivalent Circuit (Compensated Divider)

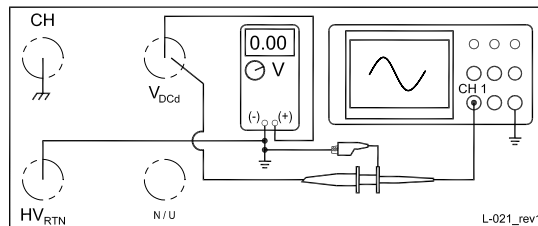

Fig. F - Electrical Connections (Compensated Divider)

**⚠ WARNING! A shock hazard exists when the chassis ground or the HV return ground is not properly connected! ⚠**



Making High Voltage Easier!®

1800 Ocean Avenue, Ronkonkoma, NY 11779  
Phone: 1-631-471-4444 Fax: 1-631-471-4696 www.ultravolt.com

# TF SERIES

## High Voltage Test Fixture

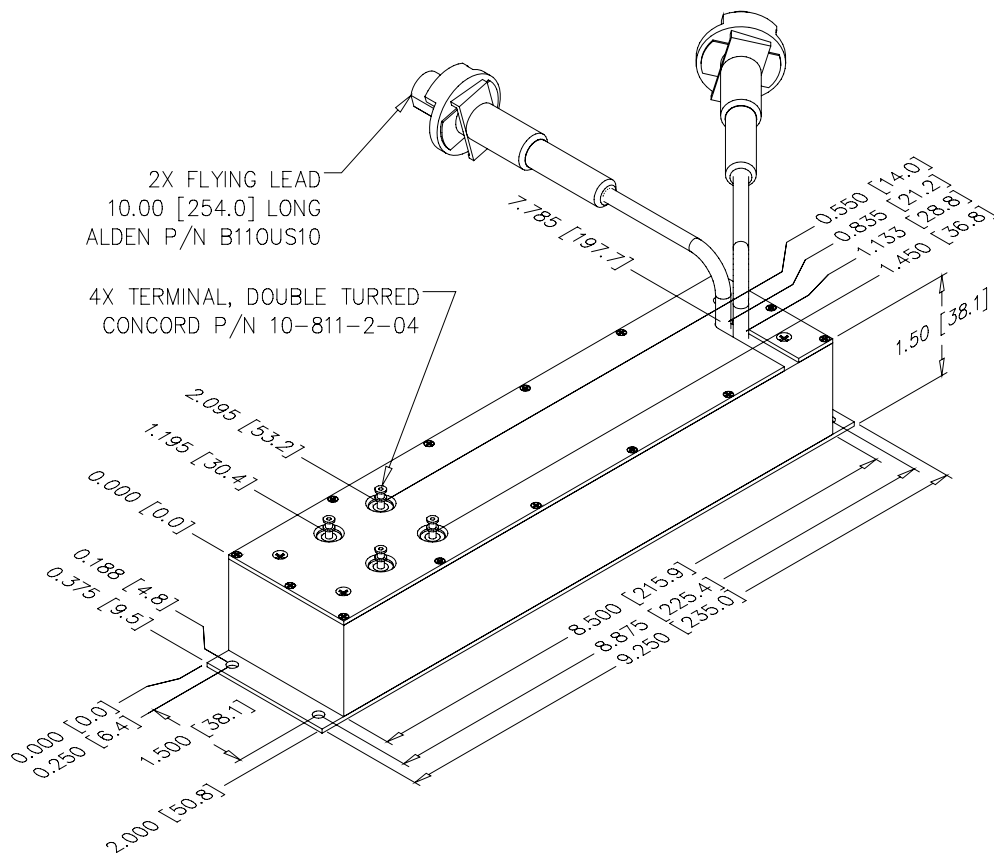

### CONSTRUCTION

Aluminum Box Anodize Gold

### SIZE

Volume 27.75in<sup>3</sup> (454.74cc)  
 Weight 1.65Lbs. (748.43g)

### TOLERANCE

Overall ±0.050" (1.27)  
 Pin to Pin ±0.015" (0.38)

[Downloadable drawings \(complete with mounting & pin information\) and 3D models are available online.](#)

### ORDERING INFORMATION

TYPE	DESCRIPTION
40TF-DCD	Precision divider
40TF-ACV&DCD	Ripple and voltage monitor
40TF-CDCD&CLOAD	Compensated divider

Popular accessories ordered with this product include our full range of high voltage output connectors (see Accessories & Connectors datasheet).



Non-RoHS compliant units are available. Please contact the factory for more information.

Manufactured in USA

Rev. J 10/14



Making High Voltage Easier!®

1800 Ocean Avenue, Ronkonkoma, NY 11779  
 Phone: 1-631-471-4444 Fax: 1-631-471-4696 www.ultravolt.com



# SAFETY AND COMPLIANCES

Certifications & Standards



IEC 60950-1, IEC 6110-1, EN 60950-1, IPC-A-610, J-STD-001

MIL-I-45208, MIL-Q-9858, MIL-STD-45662, ASTM B488, AMS 2422, IPC-2221, IPC-2222, IPC-2615, IPC-4101, IPC-4562, IPC-6012, IPC-9252, IPC-A-600, IPC-CM-770, IPC-D-325, IPC-SM-782, IPC-SM-840, J-STD-003, and MIL-STD-1686

## WARRANTY AND REPAIR POLICY

UltraVolt understands working in high voltage with new applications and new staff is sometimes unpredictable and can lead to damaged hardware. To support our customers' efforts, UltraVolt established a policy noting if a customer manages to cause one of our units to fail, UltraVolt will repair/replace the first unit accidentally damaged at no charge. If additional units are damaged during the warranty period, UltraVolt will provide replacements at half price. This is just another way UltraVolt is "Making High Voltage Easier!"®

### ULTRAVOLT, INC. WARRANTY

Warranty: The Seller warrants all goods supplied hereunder will conform to any sample approved by the parties and will be the kind described herein or in any specification, performance requirement, or drawing approved by the Seller, and will be of merchantable quality and free from defects in material or workmanship under normal use and prescribed maintenance for a period of one (1) year from the date of shipment. To the extent the Buyer does not furnish the Seller with written specifications, the goods will be manufactured in accordance with the standards recommended by the IPC-Association Connecting Electronics Industries. This warranty shall not apply to any goods delivered hereunder that have been damaged or subjected to alteration nor shall it apply to negligible treatment after delivery or to any defects attributed to artwork or drawings furnished by the Buyer. Also, unless specifically stated, the warranty does not extend to the electrical performance of any assemblies or subassemblies to which the goods furnished hereunder are affixed, but restricted to the electrical continuity properties of such goods.

The Seller's only obligation for breach of this warranty shall be the repair or replacement, without charge, of any goods or parts thereof that within such one (1) year period is proven to the Seller's satisfaction to have been defective, provided (1) the Buyer shall have notified the Seller of the defect within such one (1) year period and (2) the Seller shall have the option of requiring the return of the defective material or goods at the Buyer's expense to establish the claim provided; however, the Seller will bear any transportation costs incurred in repairing or replacing any goods that are shown to be defective during the warranty period. The cost of any repairs made by the Seller to goods no longer covered by this warranty shall be borne by the Buyer. The Buyer must contact the UltraVolt Customer Service Department prior to the return of any material(s) to obtain an RMA number which will be used to track the material. Material found to be out of warranty will be repaired or replaced at the Seller's discretion based on quantity (please contact the Customer Service Department for more information). The Seller shall in no event be liable for the Buyer's manufacturing costs, lost profits, good will, or any other special, consequential, incidental, or other damages resulting from a breach of the foregoing warranty. There are no other warranties expressed or implied (including the warranty of merchantability) that extend beyond the warranty set forth herein or that extend beyond the description of the goods contained herein.

Specifications subject to change without notice.



*Making High Voltage Easier!®*

**Higher Service, Higher Performance, Higher Reliability**

©2011, UltraVolt Inc. All rights reserved.