



PM100/300

POWER ANALYZERS

USER MANUAL

Thank you for choosing to use this Voltech Power Analyzer.
Should you experience any difficulty during the set up or use of any Voltech product, or are unsure of any of their features or abilities, please do not hesitate to contact either your local supplier or one of our Voltech offices.

Voltech Instruments Inc.
11637 Kelly Road, Suite 306
Fort Myers, FL 33908
U.S.A.
Tel: 239 437 0494
Fax: 239 437 3841
sales@voltech.com

Voltech Instruments Ltd.
148 Harwell Science and Innovation Campus
Didcot, OX11 0TR
U.K.
Tel: +44 (0) 1235 834555
Fax: +44 (0) 1235 835016
salesuk@voltech.com

WARRANTY

This product is warranted against defect in materials and workmanship for a period of one year from the date of shipment. During the warranty period, Voltech will, at its option, either repair or replace products which prove to be defective.

For repair services under warranty, the instrument must be returned to a service centre designated by Voltech. Please contact your local supplier for details.

Limitation of Warranty

The foregoing warranty shall not apply to defects resulting from unauthorised modification or misuse, or operation outside specification of instrument. No other warranty is expressed or implied.

Whilst every care has been taken in compiling the information in this publication Voltech cannot accept legal liability for any inaccuracies contained herein. Voltech has an intensive programme of design and development which may well alter product specification, and reserve the right to alter specification without notice and whenever necessary to ensure optimum performance from its product range.

Because software is inherently complex and may not be completely free of errors, you are advised to verify your work. In no event will Voltech be liable for direct, indirect, special, incidental or consequential damages arising out of the use of or inability to use software or documentation, even if advised of the possibility of such damage.

All rights reserved.

No part of this publication may be produced, stored in a retrieval system, or transmitted in any form, or by means, electronic, mechanical photocopying, recording or otherwise without prior permission of Voltech.

© Copyright Voltech Instruments Ltd 1996-2010.

Voltech Part Number 98-052 Issue 9. Aug 2010.

HEALTH AND SAFETY

Electrical devices can constitute a safety hazard. It is the responsibility of the user to ensure the compliance of the installation with any local acts or bylaws in force. Only qualified personnel should install this equipment, after reading and understanding this users guide. These operating instructions should be adhered to. If in any doubt, consult your supplier.

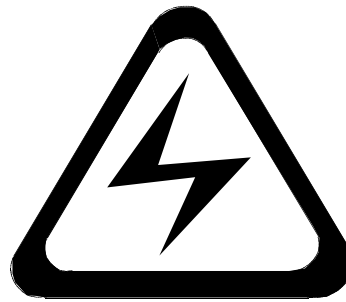

DANGER **ELECTRIC SHOCK RISK**

Please note:

This equipment is supplied under warranty conditions in force at the time of purchase from your supplier. Contact your supplier for details. Any attempt to disassemble or modify the unit will render any warranty agreement invalid.

The contents of this guide are believed to be accurate at the time of printing. The manufacturers, however, reserve the right to change the content, product specification, and performance criteria, without notice. No liability is accepted for the inappropriate, negligent, or incorrect set-up of the instrument by the user, either by manual or automated means.

CHECK YOUR LINE INPUT VOLTAGE SETTING BEFORE CONNECTING TO SUPPLY!

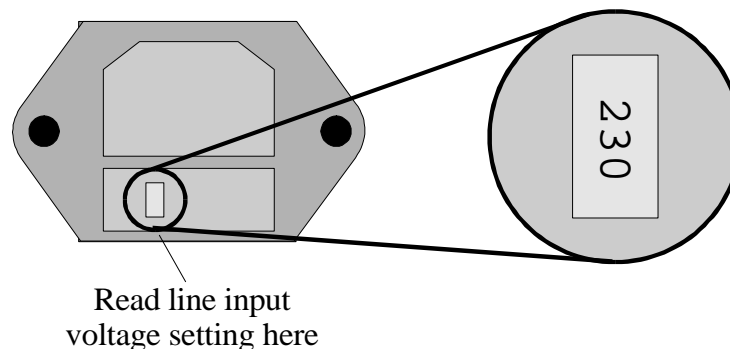

Pull out the fuse drawer and rotate the grey fuse holder to change the setting.

SAFETY PRECAUTIONS

1. The PM100 and PM300 power analyzers have been constructed in compliance with the requirements of EN61010-1, Pollution Degree 2, Installation Category II, FOR INDOOR USE ONLY. This ensures the safety of the meter and the user when normal precautions are followed.
2. **WARNING:** The analyzer **MUST** be earthed. The power source should be inserted in a socket with a protective ground contact.
3. The power source should be inserted before connections are made to measuring or control circuits.
4. Do not attempt to remove outer cover without first disconnecting auxiliary and test power supply.
5. This instrument must only be serviced by qualified personnel who understand the danger of shock hazards.
6. When the instrument is removed from its case hazardous voltages are present.
7. The electronic circuitry of this instrument is fully floating with respect to ground. If the instrument is opened and dangerous voltages (above 50V peak) applied to the input terminals then all the circuitry must be considered 'Live'.
8. The signal leads must be in good condition with no damage.
9. Use a fuse only with the same type and rating - 315mAT

CONTENTS

	PAGES
Section 1 Getting Started	1
Section 2 Function Keys	7
Section 3 The Menu System	9
Example: Low-Power Standby Measurements	19
Section 4 Calibration	21
Section 5 Specifications	25
Section 6 Accessories	29
Section 7 EMC Compliance	31

SECTION 1 - GETTING STARTED

Thank you for purchasing a Voltech Power Analyzer. Your analyzer comes supplied with:

1. This Manual
2. A Power Lead
3. Safety Insulated test leads;
 - PM100:- 2 yellow, 2 black
 - PM300:- 6 yellow, 6 black
4. Safety crocodile clips
5. A Voltech product registration card

Please report any missing items to your Voltech product supplier immediately. When you return your product registration card to Voltech, we will ensure that you continue to receive news of the latest applications software and hardware available for your power analyzer.

PM100 and PM300 power analyzers are ideal for making accurate measurements on most electrical and electronic equipment. Measurements on pulsewidth-modulated motor drives present special problems however, and we recommend the use of special 'PWM Mode' on other Voltech analyzers for this application.

All PM100 and PM300 power analyzers are supplied with a power lead, and the line voltage selector switch and menu language suitable for use in their intended destination country. Please check the line voltage setting on the IEC line socket at the back of the power analyzer.

CHANGING THE LANGUAGE

Press [MENU]

```

SELECT MENU
M[0] Outputs
  
```

Press [6] **or** [>] until you see the following display;

```

SELECT MENU
M[6] Language
  
```

Press [↵]

```

ENGLISH
x      >√<
  
```

Press [<]

```

ENGLISH
>x<    √
  
```

Press [↵] to move to the next item in the menu system,

or, press [MENU] to exit the menu system and return to the measurement display.

The menu will now be displayed in the alternative language available in your power analyzer.

ADJUSTING THE LCD DISPLAY CONTRAST

Switch the analyzer ON. Before pressing any other keys, press and hold the [$<$] or [$>$] key to adjust the display contrast to suit your angle of view. The [$<$] key will darken the display, and the [$>$] will make it lighter.

CONNECTING THE ANALYZER

Connect the analyzer as shown below. Direct connection to the analyzer's voltage and current inputs gives the best accuracy. For higher current applications that require current transformers or external shunts, see page 10.

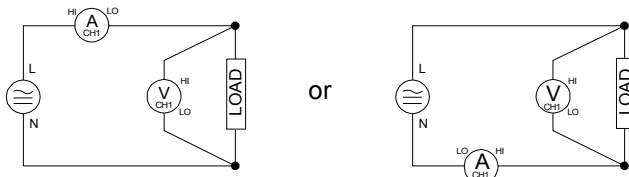

Single-phase, Two wire and DC measurements

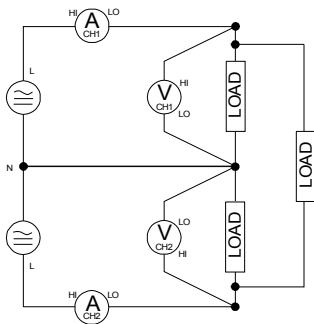

Single-phase, Three wire*

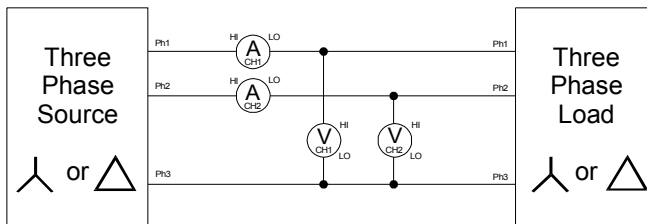

Three-phase, Three wire* (2 wattmeter method)

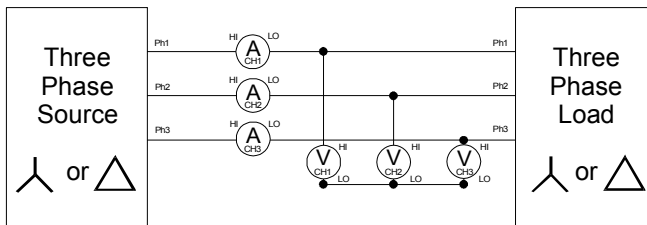

Three-phase, Three wire* (3 wattmeter method - Set Analyzer to Three Phase, Four Wire mode)

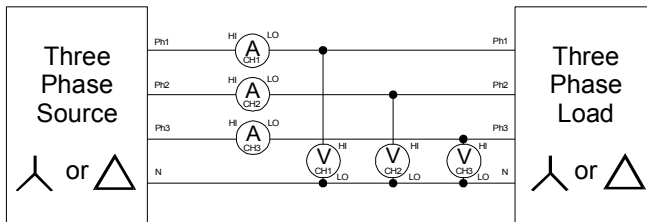

Three-phase, Four wire* (3 wattmeter method)

*PM300 only. See page 13 for selection of wiring mode.

With the analyzer connected, and with power applied, the default display shows Volts, Amps and Watts. On a PM300, quantities for 3 channels and sum are shown.

The green LED on the front panel is illuminated when the analyzer has detected a stable fundamental frequency. Harmonic measurements are invalid when this LED is not lit (when measuring DC quantities for example).

The third line of the display can be changed to show any of the 6 basic measurement functions:
(The selected measurement mode will be indicated on the display, in the position marked with a * below.)

PM100

113.0 V rms 0.524 A rms +0.000 *
--

CH1	CH2	CH3	Σ	
107.66	107.89	107.99	186.79	V rms
142.43	155.52	0.000	99.32	A rms
+0.000	+0.000	+0.000	+0.000	*

PM300

*

V

True RMS Voltage

$$V_{RMS} = \sqrt{\frac{1}{T} \int_0^T v_i^2 dt}$$

A

True RMS Current

$$A_{RMS} = \sqrt{\frac{1}{T} \int_0^T i_i^2 dt}$$

W

Real Power

$$W = \frac{1}{T} \int_0^T v_i i_i dt$$

VA

Volt - Amperes

$$VA = V_{RMS} * A_{RMS}$$

VAr

Volt - Amperes reactive

$$VAr = \sqrt{(VA)^2 - W^2}$$

PF

True Power Factor

$$PF = W / VA$$

FREQ**Frequency**

The frequency of the input waveform is obtained using the [FREQ] key. The lowest of the frequencies detected on the Channel 1 V and A inputs is displayed. This frequency is used as the fundamental for harmonic analysis.

FUND**Fundamental value.****V.f, A.f, W.f, VA.f, Var.f, PF.f**

The fundamental (1st Harmonic) component of the 6 basic measurements are quickly shown by using the [FUND] key.

PF.f is the power factor due to the fundamental components of voltage and current. This is equivalent to $\cos\phi$ in a sinewave system. $\cos\phi$ has a sign to denote leading or lagging current, and the convention used is shown below:

	0°	-90°	-180°	-270°	-360°
W	+	-	-	+	
PF.f	-	-	+	+	
Var.f	+	+	-	-	

For Watts, + or - indicates the direction of the power flow.

For PF.f, + indicates that I leads V (Capacitive).

For Var.f + indicates an inductive load.

The sign used to indicate fundamental power factor may be reversed in menu 4.

For example;

Press [MENU]

```

SELECT MENU
M[0] Outputs

```

Press [4] or [>] until you see the following display;

```

SELECT MENU
M[4] Key Options

```

Press [↵]

```

PF LEADING
>-<      +

```

Press [<] and [>] to make your selection

```

PF LEADING
-      >+<

```

Press [↵] to move to the next item in the menu system,

or, press [MENU] to exit the menu system and return to the measurement display.

Four further types of measurement are available. These are associated with only specific basic measurements. Attempting to show 'VA' 'PEAK' for example will result in a parameter error.

PEAK

Peak value of the waveform V pk, A pk.

Display of crest factor may be selected in menu 4. Select V cf, A cf by using the [V] and [A] keys in [PEAK] mode. Press [PEAK] again to cancel.

Press [MENU]

```
SELECT MENU
M[0] Outputs
```

Press [4] or [>] until you see the following display;

```
SELECT MENU
M[4] Key Options
```

Press [↵] until you see the following display;

```
PEAK
>pk<   cf
```

Press [<] and [>] to make your selection

```
PEAK
pk     >cf<
```

Press [↵] to move to the next item in the menu system,

or, press [MENU] to exit the menu system and return to the measurement display.

HARM

Displays either Voltage (Vhxx), Current (Ahxx), or Power (Whxx) harmonics by pressing the [V], [A], or [W] keys.

Press [HARM] again to cancel harmonic display.

PM100

AH01	AH03	→	1st, 3rd current harmonic
2.47	0.526	→	Amplitude of harmonics in Amps
-015.1°	-160.8°	→	Phase of harmonic relative to VH01

PM300

CH1	CH2	CH3	Σ	V rms
96.88	97.08	97.78	168.44	AH01
121.13m	134.38m	128.47m	127.99m	°
-002.3	-120.6	-242.4		

- ➔ Amplitude of harmonic in Amps
- ➔ Phase of harmonic

Use the [<] and [>] keys to scroll through harmonics 0 (dc) to 50.

Harmonic amplitude can be shown as absolute values by selecting 'V/A/W' in menu 2. (See page 12 for example.)

THD**Total Harmonic Distortion. V thd, A thd.**

The power analyzer automatically selects the most accurate method of calculation, depending on the level of THD. Press [A] or [V] to select A thd or V thd. Press [THD] again to cancel THD display.

$$\text{THD} > 6\% \quad df = \frac{\sqrt{(RMS^2 - H1^2)}}{H1} \times 100\%$$

$$\text{THD} < 6\% \quad thd = \frac{\sqrt{H2^2 + H3^2 + H4^2 + H5^2 + \dots}}{H1} \times 100\%$$

See also the in [MENU] [4] for how to manually select the formula that is used and [MENU] [2] for how to change the harmonic reference (the denominator in the equations above).

INTG**Displays Integrated values.**

Ah, Wh, VAh, VARh, PF (Average) and fundamentals are valid.

The period of integration is set in menu 2. Pressing the [INTG] key starts integration, and displays any of the integrated values during integration.

Pressing the [INTG] key again returns the display to normal mode, integration continues in the background until the time set in menu 2 is reached.

The orange LED is lit when the integrator is running. Press and HOLD the [INTG] key to stop integration.

SECTION 2 - FUNCTION KEYS



Press and HOLD this key to toggle between default (Red LED off) and stored settings (Red LED on).



Enter and exit the menu system.

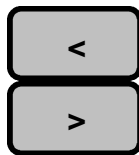

Move through menus, select settings etc. Clear erroneous menu data.



When measuring: acts as a HOLD key (toggle). In the menu system: acts as the ENTER key.



PM300 only. Selects Channel on Display. Toggles display of Σ quantities and Neutral Amps.

When in 1ph 2W mode, pressing the [DISP] key sequences through measurements on all 3 channels. In this mode, all 3 channels are operating independently of each other and are able to make measurements on different ranges and at different frequencies.

For waveform display, the [DISP] key sequences through the following displays:

1/ V & A	CH1
2/ V & A	CH2
3/ V & A	CH3
4/ V	CH1, CH2 and CH3
5/ A	CH1, CH2 and CH3
6/ V & A	CH1, CH2 and CH3

For bargraph display, the [DISP] key sequences through the following displays:

1/ V & A	CH1
2/ V & A	CH2
3/ V & A	CH3

SECTION 3 - THE MENU SYSTEM

MENU

Allows access to the analyzer menu system.

To navigate the menu system, press the [MENU] key and select the menu you require, either by pressing one of the number keys corresponding to the menu number, or [>] until you see the menu displayed. When the display shows the required menu, press [↵] to access it. To change options within a menu, use the [>] and [<] keys to move the flashing '>' '<' around the desired option and press [MENU] to return to the measurement display, or press [↵] to move to the next menu option.

For example, to access the **M[4] key options** menu and change the display to show crest factor instead of peak;

Press [MENU] and the display will show;

```
SELECT MENU
M[0] Outputs
```

Press [4] or [>] until you see;

```
SELECT MENU
M[4] key options
```

Press [↵] until the following display is shown;

```
PEAK
>pk<      cf
```

To change the option;

Press [>] to select >cf<

Press [↵] to move to the next item in the menu system,

or press [MENU] to exit the menu system and return to the measurement display.

All settings are stored when the analyzer is switched off, and may be restored by pressing the [PROG] key.

The following menu options are available.

M[0] Outputs

Select plug-in interface options.

Options are defined in the user manual supplied with the separately purchased interface.

M[1] Inputs

1ph 2W	>x<	or	✓	See connection diagram on page 2
1ph 3W	>x<	or	✓	See connection diagram on page 2
3ph 2W	>x<	or	✓	See connection diagram on page 2
3ph 4W	x	or	>✓<	See connection diagram on page 2
External Shunt	>x<	or	✓	
Voltage Scaling	>x<	or	✓	Enter scale factor
Current Scaling	>x<	or	✓	Enter scale factor
Manual V Range*	>x<	or	✓	Enter peak volts
Manual A Range*	>x<	or	✓	Enter peak amps
Fix Freq Source*	>x<	or	✓	Amps or Volts

M[2] Modes

Inrush Current	>x<	or	✓	
Integration Time	HH:MM			Enter Time (HH:MM)
Ballast Mode	>x<	or	✓	50Hz or 60Hz
Harmonic Mode	>%<	or	V/A/W	
Waveform	>x<	or	✓	
Barchart	>x<	or	✓	
Fast Mode	>x<	or	✓	
Long Averaging*	>x<	or	✓	Enter Time (secs)
Disable Blanking	>x<	or	✓	

M[3] Display

Upper Function	>V rms<
Middle Function	>A rms<

M[4] Key Options

PF Leading	> - <	or	+	(Sign of PF when I leads V)
Peak	>pk<	or	cf	(Display peak or crest factor)
Fix THD Formula	>x<	or	✓	(Auto or fixed formula select)
Series Formula	>x<	or	✓	(Choose fixed formula)
RMS Harmonic Ref	>x<	or	✓	(Reference for THD formula)

M[5] Calibration

Password	>0<	(The factory default is 3000)
----------	-----	-------------------------------

M[6] Language

English	x	or	>✓<
---------	---	----	-----

Select Menu

>x<	or	✓
-----	----	---

*PM100 only.

M[0] Outputs

This menu is only available when a Voltech interface card is fitted. See page 23 for a full description of the cards available for your analyzer. For operating instructions, see the manual supplied with the interface card.

M[1] Inputs

The PM100 / 300 analyzers are highly versatile and can be configured to analyze almost any electrical system. The versatility is achieved because all power inputs are ac + dc coupled, and are isolated from each other and from the ground.

The four main wiring modes are:-

[1 ϕ 2W] SINGLE PHASE, TWO WIRE.

Select for single phase loads, two wire distribution system and rectifier output.

[1 ϕ 3W] SINGLE PHASE, THREE WIRE.

Select for three wire single phase distribution systems.

[3 ϕ 3W] THREE PHASE, THREE WIRE.

Select for three phase loads without neutral connection (two wattmeter method). Note that the [N] channel provides computed values of current (Arms, Afund, Acf, Apk, Aharm and Athd) for the third (unmeasured) phase of the system.

[3 ϕ 4W] THREE PHASE, FOUR WIRE.

Select for three phase loads with or without neutral connection (three wattmeter method).

External Shunt

For use with external shunts and other devices that produce a voltage proportional to the current being measured (E.g. some DC coupled current transformers.) The proportional voltage is applied between the 'EXT' and 'LO' terminals.

Example:

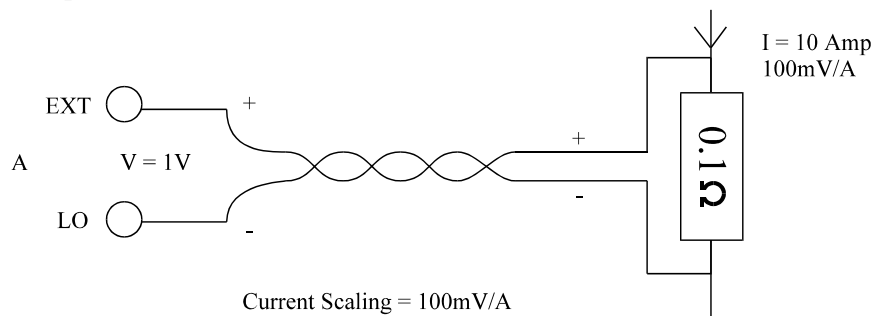

The scale factor is entered directly in mV/A. A twisted pair connection is recommended to minimize noise pick-up.

Voltage Scaling and Current Scaling

For use with voltage transformers / dividers and current transformers.
Connect to the V HI and LO terminals for voltage probes, and to the A HI and LO terminals for current probes.

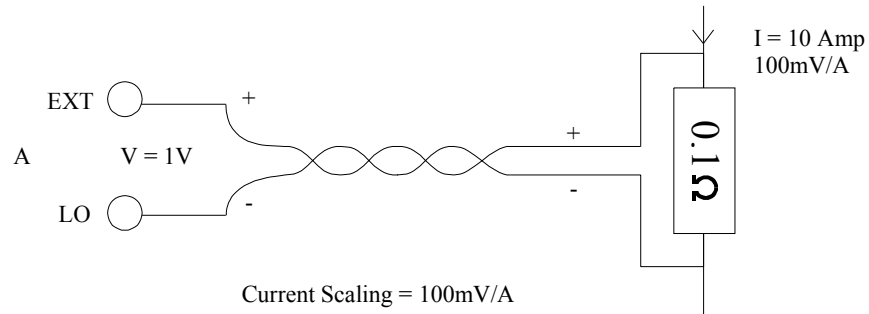

Note: When using 1000:1 CT as in the above example, enter '1000' as the current scaling.

Manual Ranging. (PM100 Only)

By default, the analyzers are fully auto-ranging. This is the ideal setting for most applications since the analyzers will then always be operating on the optimum range. No settings are required by the user in this case.

In measurement applications where there are transients or bursts of signals, then data may be lost due to the time taken by the analyzer to perform the automatic range selection. In this case, the auto-ranging may be switched off and a manual range selected.

The PM100 has 8 current and 8 voltage ranges as described below.

To set a manual range, simply select '✓' for Manual V Range or Manual A Range in **M[2]** and then enter the approximate maximum peak current or voltage that is expected. (This can be measured by pressing the PEAK key). It is not necessary to remember the exact ranges of the PM100, since they will be selected for you according to the following tables.

Amps Peak Range	Amps Peak Entered
0.1	0.0 ≤ 0.1
0.3A	0.1 ≤ 0.3
0.9A	0.3 ≤ 0.9
2.7A	0.9 ≤ 2.7
8.1A	2.7 ≤ 8.1
24.3A	8.1 ≤ 24.3
72.9A	24.3 ≤ 72.9
200A	> 200

Volts Peak Range	Volts Peak Entered
7.5V	0.0 ≤ 7.5
15V	7.5 ≤ 15
30V	15 ≤ 30
60	30 ≤ 60
120V	60 ≤ 120
240V	120 ≤ 240
480V	240 ≤ 480
1000V	> 480

When a manual range is set, the analyzer will make accurate measurements for signals up to the specified range peak.

Notes.

- 1) Small signals may not be displayed because of the analyzer's display blanking feature and this should be disabled. See **M[2]** 'Disable Blanking'.
- 2) Scaling is ignored. When setting a manual range, use the actual peak current or voltage seen at the terminals of the PM100.

Fixed Frequency Source (PM100 Only)

It is important that the analyzer detects the correct frequency for analysis since this frequency is used in the calculation of rms and harmonic measurements. Good frequency detection is indicated by the green led on the front panel.

Normally, the analyzers continuously scan both the voltage and current channels for frequency and this is the ideal method for most measurement applications. It is not usually necessary to adjust this setting.

In measurement applications where there are transients or bursts of signals, then the analyzer may lose frequency synchronization momentarily. The green led will not be lit and the measurements may be unstable.

To correct this problem, choose a fixed frequency source '✓'. If the voltage is always present and stable, choose 'Volts'. If the current is always present and stable, choose 'Amps'.

M[2] Modes**Special operating modes of the analyzer.**

Note: To exit the mode you are in and return to default set up, press the [PROG] key.

Inrush Current

The analyzer continuously monitors the current channels and displays the largest peak current observed. Only the [<] and [>] keys operate to reset the display. Auto-ranging is disabled in this mode, so the expected peak value must be entered. If in doubt, enter '200' Amps when prompted, and then reduce this value to improve resolution and accuracy.

When using the inrush current mode on the PM100, it is advisable to first set manual range as describe on page 12 to monitor the signal before the inrush mode is issued. This will aid in setting the correct range for inrush current measurements.

'CURRENT OVERRANGE' is displayed if the selected peak value is exceeded.

Press [PROG] to deselect Inrush Current mode to make other measurements.

Integration Time

This is the time that the integrator will run for. See the [INTG] key.

Ballast Mode

The output of electronic and some ultrasonic equipment consists of a high frequency waveform heavily modulated at the line frequency.

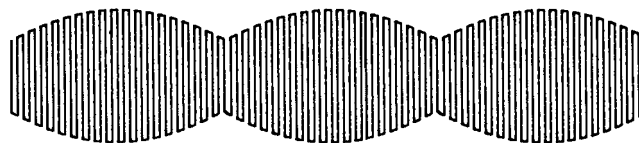

To make accurate measurements, the whole cycle at 50 or 60 Hz must be analyzed. To do this, select 'Ballast Mode' and choose 50 or 60 Hz.

To give the best measurement accuracy, it is recommended that the Voltech Ballast CT (current transformer) be used where high common mode voltages are present.

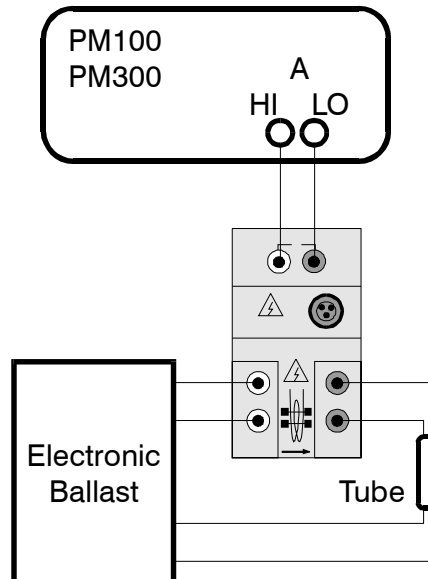

Harmonic Mode

Harmonic Amplitude may be displayed as a percentage (%) of fundamental or in RMS terms as desired.

Press [MENU]

SELECT MENU
M[0] Outputs

Press [>] until you see;

SELECT MENU
M[2] Modes

Press [↵] until you see;

HARMONIC MODE
>%< V/A/W

Press [<] and [>] to make your selection.

Press [↵] to move to the next item in the menu system,

or, press [MENU] to exit the menu system and return to the measurement display.

Waveform Display Mode

This mode displays one cycle of the input waveforms. The waveforms are automatically scaled to fit the display, voltage on CH1 always being the larger. Since the waveforms are scaled for easy viewing, they should not be used for comparative measurements. The peak values of the waveform are shown alongside. This mode is not available in Ballast mode.

Barchart Display Mode

Displays bargraphs of voltage or current harmonics. All 50 harmonics are displayed, and individual detail can be displayed by pressing the [<] or [>] keys to scroll through the harmonics.

Fast Mode

In this mode the display averaging is reduced to provide a rapid response to changing inputs. This mode is not available in Ballast mode.

Long Averaging (PM100 Only)

This mode may be used to average measurements over a long interval from 10 to 300 seconds.

Normally, the PM100 samples the waveforms at 200kHz and updates the display approximately every ½ second. This is ideal for most measurement applications.

When there are transient or burst signals, however, and it is the average measurements over a long period of time that are required, then 'Long Averaging' should be enabled. '✓'.

The averaging time should be several times longer than the cycle of operation of the equipment under test. See also the 'low-power standby measurements' example later in this manual.

Equipment Cycle Time	Example	Long Averaging Time
< 1 second	Power supply in low power standby mode.	10s
1 < 10 sec	Signs, message boards, oscillating fan.	100s
10 < 60 sec	Soldering iron.	300s
> 60 sec	Washing machine	300s + Integrator.

All measurements, including harmonics, are available in long averaging mode.

Notes.

- 1) The display update rate varies with the averaging time used (10 to 3000 seconds). To indicate the analyzer is averaging, the red PROG led flashes whenever this mode is enabled.
- 2) To reset the averaging, press the PROG key.
- 3) To cancel this mode, return to the menu system and disable Long Averaging.
- 4) For equipment with very long cycles of operation (e.g. washing machine) use the long averaging mode and the integrator together.
- 5) The sample rate in this mode is 200kHz.
- 6) If this command is not documented in your RS232 or IEEE488 interface card manual, the format is :AVG:LNG nnn where nnn is an integer in the range 10 to 300. :CFG 1,0 & :AVG:AUT or :AVG:FIX nn must be used to return to normal mode.

Disable Blanking

Normally, small signals which are below the specified range of the analyzer are not displayed. The display is 'blanked'. To view small signals, disable the blanking by selecting '✓'. For best accuracy, however, bring the signals into the normal operating range of the analyzer. A simple external resistive shunt is often used for low current applications. See the technical note at www.voltech.com

M[3] Display

This display enables the user to change the top and middle functions of the screen to one of the six basic functions as shown on page 3. The bottom line of the numeric display is automatically changed depending on which one of the six basic functions are selected. For example:

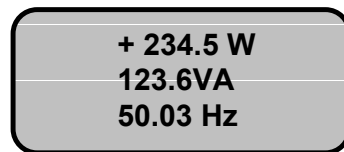
**M[4] Key Options****PF Leading**

Normally the convention used is >+< means I leads V. This may be reversed by selecting >-< means I leads V.

Peak

Pressing the [PEAK] key normally displays the repetitive peak value of the voltage or current waveform. This may be changed here to display the Crest Factor, CF, where $CF = \text{Peak} / \text{RMS}$ values of the waveform. For a sine wave the CF is 1.414.

Fix THD Formula

Normally, the analyzer automatically selects the optimum THD formula. The formula may be set manually by selecting '✓'.

Series Formula

This menu is only available if 'Fix THD Formula' has been selected as above. Select '✓' to use the series formula only, 'x' to use the difference formula. See Page 6.

RMS Harmonic Ref

Normally, the reference value used during THD calculation is the fundamental or H1. Select '✓' to use the rms value as the reference. See page 6.

M[5] Calibration

See page 17 for a full description of this menu.

M[6] Language

English or an alternative language may be selected for the menus.

Select Menu

By selecting >✓< at this menu, the screen will switch to the first menu option, **[M0] Outputs** and you may now scroll through all the menu options once again. If you wish to exit the menu system, select >x< at this menu and press [-]. Alternatively, press the [MENU] key to return to the measurement display.

APPLICATIONS EXAMPLE – LOW-POWER STANDBY MEASUREMENTS.

An ac power supply is equipped with a low-power standby mode. In this mode, current is drawn from the supply in ‘bursts’ that occur every 300ms or so. The waveform is shown below.

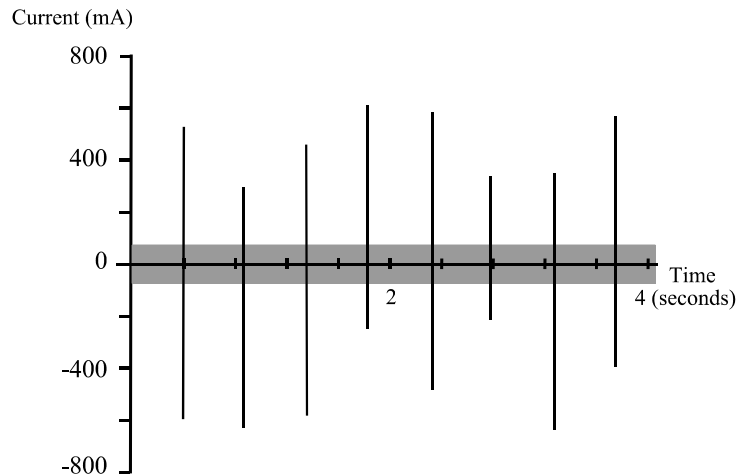

A measurement of the average input power is required to check the rating of the power supply. With default settings, the PM100 makes measurements at high speed and updates the display approximately every ½ second. With the waveform above, the measurements are not stable, and the analyzer pauses while it auto-ranges in between readings.

To make stable average measurements, follow this procedure.

1. Measure the peak current.
In normal power on mode, press the **[A]** key and then the **[PEAK]** key. Amps peak will be displayed. In this example, the maximum reading was approximately -750mA.
2. Set up a fixed current range.
Press **[MENU]**, **[1]** and then **[↔]** until you see:

```

MANUAL A RANGE
x >✓<
  
```

and then enter the nominal peak current, ignoring the (-) sign:

```

PEAK CURRENT
>0.750<
  
```

3. Now set up long averaging in **[MENU]**, **[2]**.

```

LONG AVERAGING
x >✓<
  
```

The averaging time should include several cycles of operation of the equipment. In this case, the power supply current seems to vary over a 2 second period. Choose 20 seconds for the averaging time. This can be increased later if the measurements are not stable.

AVERAGING TIME >20.0<

4. Disable blanking.
Small signals (typically less than 10% of range) are not displayed by the analyzer. This is normal for auto-ranging instruments. When the analyzer is manually ranged, the display blanking should be disabled so that small signals are measured properly.

In [MENU] [2]

DISABLE BLANKING x >✓<

5. Press [MENU] again and the analyzer will now begin to make measurements. The red PROG led will flash to indicate that the PM100 is in long averaging mode. The display update rate will vary with the averaging time, but the analyzer is making continuous measurements and averaging them together. All measurements, including harmonics, are available.

Notes:

- i) For improved accuracy for currents less than 10mA, use an external shunt or transducer. See www.voltech.com for a technical note.
- ii) If you see the message 'CURRENT OVERLOAD', re-measure the peak current and adjust the manual current range setting. The analyzer will not be damaged by range overloads as long as they do not exceed the maximum ratings given in the specification.
- iii) The maximum long averaging time is 300 seconds. For averaging over longer periods, enable long averaging at 300 seconds and use the integrator as well.

SECTION 4 - CALIBRATION

Calibration of your analyzer is valid for 12 month periods. If any input range is uncalibrated, the analyzer displays 'CALIBRATION ERROR' on power up. This may be bypassed by pressing the [↵] key.

Equipment Required:

- High accuracy (0.02%) true RMS volt meter.
- 0-20A rms Current Generator, 120Hz
- 0-1000V rms Voltage Generator, 120Hz
- 1.000Ω precision shunt. (For < 2A rms)
- 0.1000Ω precision shunt. (For > 2A rms)

Equipment Connections:

IMPORTANT NOTE:

For optimum performance, always calibrate with BOTH voltage and current present simultaneously.

- During voltage calibration, apply approximately 100mA from the same ac source to the current channel.
- During current calibration (including external shunt), apply approximately 5V from the same ac source to the voltage channel.

For Voltage Calibration

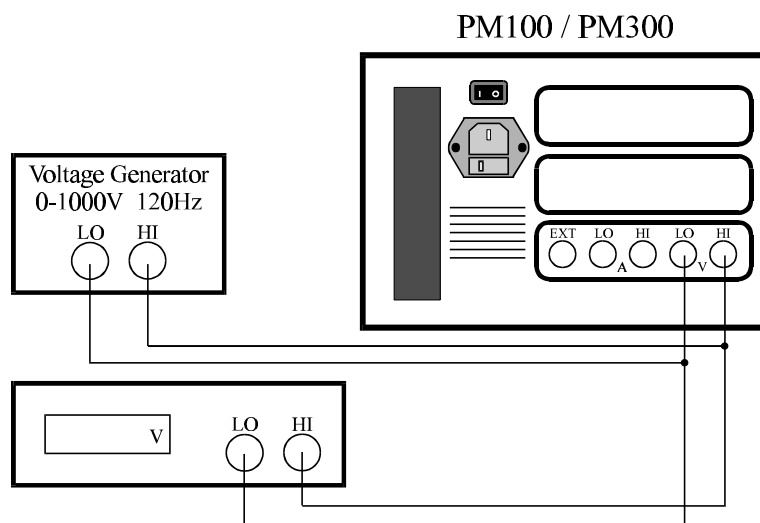

For Current Calibration

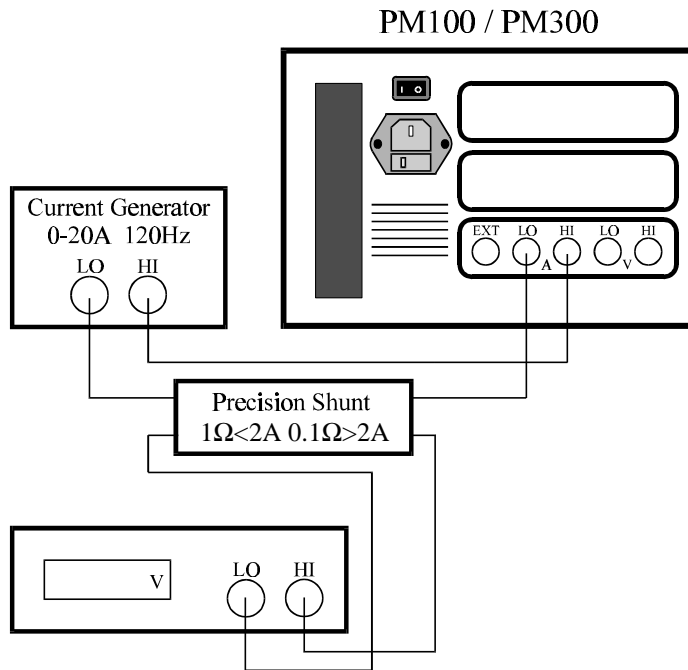

For Current Calibration (External Shunt)

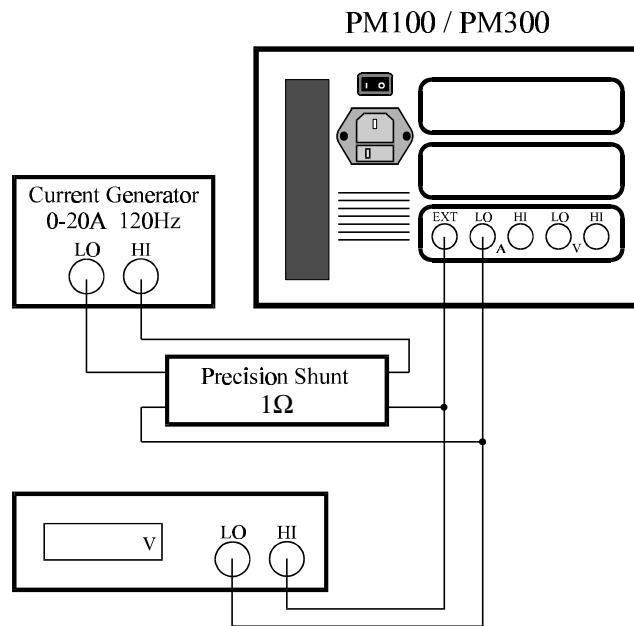

Calibration Method:

Press [MENU] and the display will show;

SELECT MENU M[0] Outputs

Press [5] or [>] until you see;

SELECT MENU M[5] calibration

Press [↵] and the following display will be shown;

ENTER PASSWORD >0<

Enter the password using the number keys (the factory default is >3000<) and then press [↵].

The next display will show;

CHANGE PASSWORD >x< √

Press [↵] to continue without changing the password.

To change the password, select >√< using the [>] key and press [↵].

The display will then show;

ENTER PASSWORD >0<

Enter the new password using the number keys and then press [↵].

The display will now show;

CALIBRATE VOLTS >x< √

Select >√< and press [↵]

For each of the seven ranges per channel (VR1 to VR8), set up approximately the required voltage using the equipment connected as shown on page 15 for voltage calibration.

Enter the voltmeter reading into the PM100 or PM300 and press [↵]. Use [>] and [<] to delete incorrect entries.

The display will show;

CALIBRATION BUSY

for a short time, followed by

CALIBRATION PASS

to continue, or;

CALIBRATION FAIL

If 'FAIL' is displayed, press [←] to retry.

To skip a range, press [↵] when the display shows >0<.

When 'PASS' is displayed, press [↵] and the display will show;

CALIBRATE AMPS >x< √

To calibrate amps, select >√< and press [↵]. The process is similar to the calibrate volts procedure, for the current ranges AR1 to AR8. Connect the equipment as shown on page 15 for internal shunt calibration, and enter the current value which is voltmeter reading / shunt resistance.

The next option in the calibration menu system is 'CALIBRATE EXT'. For the external current ranges XR5 to XR8, connect as shown on page 16 for external shunt calibration and enter voltage values.

The last menu in the calibration options is;

SAVE CALIBRATION >x< √

Select >√<, and press [↵] to store the new calibration constraints.

Note: Any stage of the calibration may be omitted. New calibration constants will only be used where they are entered. Entering [0] for any value causes the previously stored calibration to be used for that range.

SECTION 5 - SPECIFICATION (AT 23°C ±5°C, 30 MINUTES WARM-UP.)**Voltage**

Ranges (auto ranging)		2Vrms to 1000V pk in 8 ranges : 7.5, 15, 30, 60, 120, 240, 480, 1000 Vpk
Accuracy	5Hz to 1kHz 1kHz to 50kHz* DC	±0.1% reading ±0.1% range ±10mV ±0.1% rdg ±0.1% rng ±10mV ±0.1%/kHz ±0.1% rdg ±0.1% rng ±10mV
Crest Factor		Up to 20
Max input	Continuous 1 sec	1000V pk 1500V pk
Input Impedance		>1MΩ in parallel with <10pF
Effects of Common Mode Voltage	500Vrms 120Hz 100Vrms 10kHz	Less than 500mV Less than 1V
Impedance to ground		Galvanic isolation. Capacitance approx. 100pF

Current

Ranges (auto ranging)		20mArms to 20Arms in 8 ranges : 0.1, 0.3, 0.9, 2.7, 8.1, 24.3, 72.9, 200.0 Apk
Accuracy (excluding Neutral)	5Hz to 1kHz 1kHz to 50kHz* DC	±0.1% reading ±0.1% range ±1mA ±0.1% rdg ±0.1% rng ±1mA ±0.2%/kHz ±0.1% rdg ±0.1% rng ±2mA
Crest Factor		Up to 20
Max input	Continuous 1 sec	20Arms, 200Apk (16Arms when all three channels used on PM300) 60Arms
Input Impedance		12.5mΩ on all ranges
Effects of Common Mode Voltage	500Vrms 120Hz 100Vrms 10kHz	Less than 50mA Less than 50mA
EXT. SHUNT		
Range		12.5mVrms to 2.0Vpk
Equivalence	12.5mV/A	
Accuracy	5Hz to 50kHz*	±0.1%rdg ±0.1%rng ±1mV ±0.2%/kHz
Max input	Continuous	250Vrms
Input Impedance		1MΩ on all ranges
Impedance to ground		Galvanic isolation. Capacitance approx. 100pF

*5Hz to 20kHz for the PM300 in three-phase, three-wire and three-phase, four wire modes.

Power

Display Range	0 to 1,999GW
Accuracy	$\pm 0.2\%$ rdg $\pm 0.2\%$ rng $\pm 5\text{mW}$ $\pm 0.3\%$ /kHz

Apparent Power

Display Range	0 to 1,999GVA
Accuracy	$\pm 0.2\%$ rdg $\pm 0.2\%$ rng $\pm 5\text{mVA}$ $\pm 0.3\%$ /kHz

Reactive Power

Display Range	0 to 1,999GVAr
Accuracy	$\pm 0.2\%$ rdg $\pm 0.2\%$ rng $\pm 5\text{mVAr}$ $\pm 0.3\%$ /kHz

Power Factor

Range	0.000 to ± 1.000
Accuracy	± 0.004 $\pm 0.2\%$ rdg $\pm 0.2\%$ / kHz

Crest Factor

Range	1.000 to 19.999 (Ranges 2 to 8 only)
Accuracy	\pm (% pk error + % rms error)

Peak Voltage and Current

Accuracy	$\pm 1\%$ rdg $\pm 1\%$ rng $\pm 0.2\%$ /kHz (Ranges 2 to 8 only)
----------	--

Inrush Current

Range	0-200A
Accuracy	$\pm 3.0\%$ rdg $\pm 3.0\%$ rng $\pm 50\text{mA}$

Frequency

Range	5Hz to 50kHz*
Accuracy	0.2% rdg

*5Hz to 20kHz for the PM300 in three-phase, three-wire and three-phase, and four-wire modes.

Harmonics

Range		0 to 50
Bandwidth	Fundamental	5Hz to 50kHz*
	Harmonics	10Hz to 250kHz
Accuracy	Fundamental Volts	$\pm 0.1\%$ rdg $\pm 0.1\%$ rng $\pm 10\text{mV}$ $\pm 0.1\%$ /kHz
	Amps	$\pm 0.2\%$ rdg $\pm 0.1\%$ rng $\pm 1\text{mA}$ $\pm 0.2\%$ /kHz
	Harmonics	$\pm(0.2 \pm 0.1/\text{kHz})\%$ of fundamental

THD

Range	0% to 999%
Accuracy	$\pm 0.4\%$ rdg $\pm 0.1\%$ / kHz

Integrator

Range	1min to 99hrs 59mins
-------	----------------------

Environment

	Operating	0 to +40°C
	Shipping	-20 to +60°C
Safety	Designed to comply with EN61010-1	
	Pollution Degree 2, Installation Category II	

Power Source

	110V	90V to 132V
	230V	195V to 265V
	Frequency	48Hz to 65Hz
	MAX. VA	25VA
	Fuse Type & Rating	315mAT

Dielectric Strength

	Input - Case	4kV AC 50/60 Hz for 1 minute.
	Input - Power Srce	4kV AC 50/60 Hz for 1 minute
	Power Srce - Case	1.9kV DC for 1 minute

*5Hz to 20kHz for the PM300 in three-phase, three-wire and three-phase, four wire modes.

SECTION 6 - ACCESSORIES AVAILABLE FOR THE PM100 AND PM300

A number of interfaces have been designed for use with the PM100 and PM300 power analyzers:

IEEE488.2 Interface.

Full implementation of the IEEE488.2 bus communication standard using the latest National Instruments compatible circuits. Allows full control of the analyzer remotely. IEEE address may be any number from 2 to 30.

Centronics (parallel) and RS232 (serial) Interface.

The parallel connector (a 25 way D-type) connects to most printers with a Centronics type interface - matrix, jet and laser. User selected text is printed when the [↵] key is pressed.

The RS232 connector (a 9 way D-type) may be used to connect to a serial printer, or to allow full remote control for the analyzer using the IEEE488.2 command set. The baud rate (1200 to 19200) is selected from the front panel.

Chart Recorder and Alarm Contacts Interface.

12 measurements may be output onto a 15-way D-type for connection to a chart recorder or data logger. Each measurement is scaled for MAX and MIN level from the front panel.

2 isolated alarm relay contacts are also provided (rated 50V @1A) for plant control. The relays may be programmed (via the front panel) to operate when any measurement exceeds a preset MAX or MIN level. Extra integration features are provided for load shedding and peak demand applications.

Voltech can also supply a range of current transformers:

CT1000

Precision AC 0.2% dual ratio current transformer. 100A:1A and 1000A:1A.

CL1000

AC clamp-on current transformer. 1000A:1A

CL100

AC clamp-on current transformer. 100A:1A

Lighting Ballast CT

5mA to 1A RMS current in two ranges.

5 kHz to 1MHz bandwidth.

Maximum voltage (Ballast/Tube to output) - 1000vpk.

Accuracy (20kHz to 500 kHz):

- Amplitude better than 1%
- Phase (current output) better than 1°
- Phase (voltage output) better than 3°

Please contact Voltech for details of the accessories and applications currently available.

RACK MOUNTING DETAILS FOR THE PM100 AND PM300

IMPORTANT: Detail applies to PM100 / PM300 manufactured from late 2010 onwards. Models made from 2001 to mid 2010 have a different placement of the feet. Please request an issue 8 user manual. Models prior to mid 2001 have a case which is split along its sides and different drilling details apply. Request an issue 4 manual.

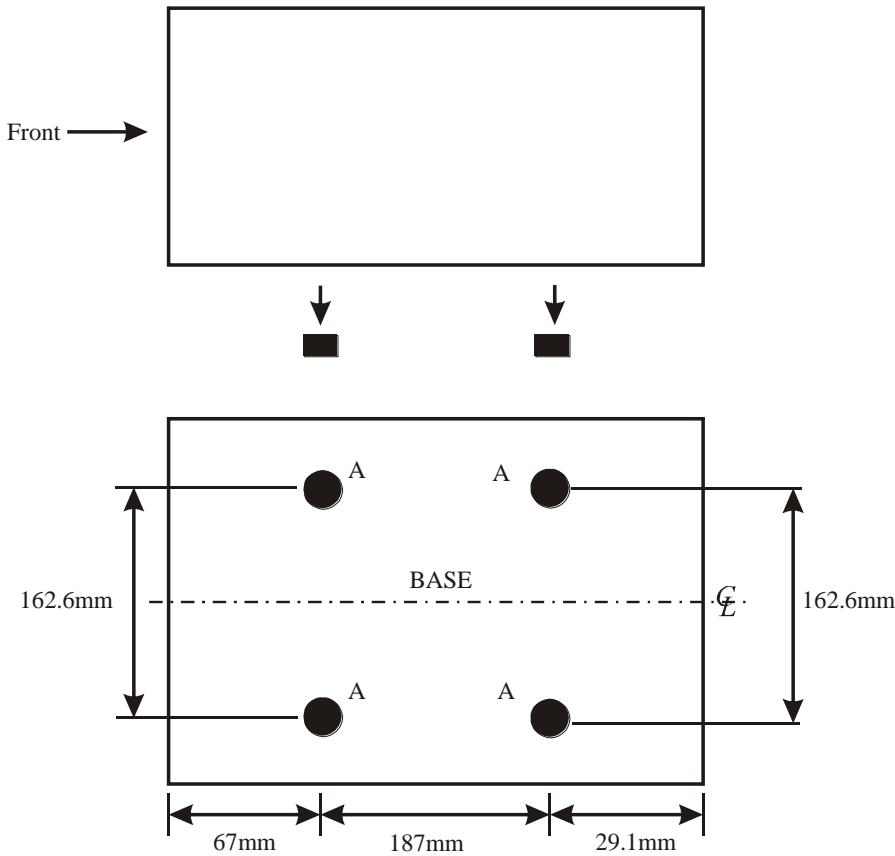

Remove feet

A: 4 holes M3 thread
Screw length:
10mm Max

Drill rack tray with 4mm clearance holes.

Assemble using M3x10mm pan head screws and washers. Do not overtighten.

Two analyzers may be fitted side by side on one tray.

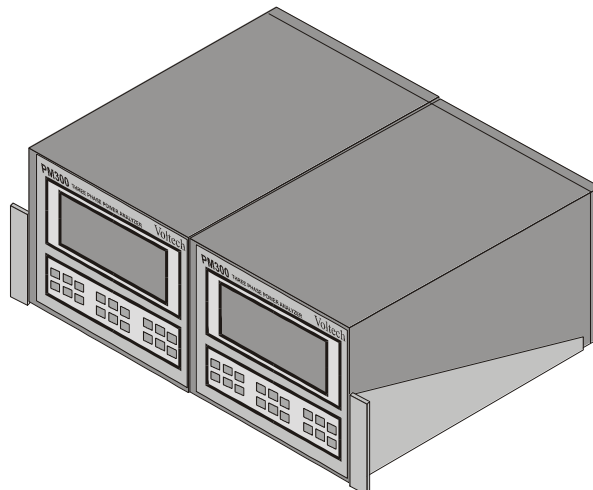

Suitable shelves are 400mm deep Imrak 19" Cantilever shelves. Part Number : 802-562285B or similar.

SECTION 7 - EMC COMPLIANCE**DECLARATION OF CONFORMITY**

Manufacturer's Name Voltech Instruments Ltd
Manufacturer's Address 148 Harwell Int'l Business Centre
Abingdon, Oxon
United Kingdom

declares, that the product

Product Name: Power Analyzer

Model Number: PM100

conforms to the following Product Specifications

Safety: BS EN 61010 (1993)

EMC: BS EN 55022 (1995): Class A
BS EN 50082-2 (1992)

Supplementary Information: The product herewith complies with the requirements of the EMC Directives 89/336/EEC and 92/31/EEC and the Low Voltage Directive 73/23/EEC

Signed for on behalf of Voltech Instruments Ltd

Martin Whitley, Quality Manager

Abingdon, United Kingdom June, 1996

DECLARATION OF CONFORMITY

Manufacturer's Name Voltech Instruments Ltd
Manufacturer's Address 148 Harwell Int'l Business Centre,
Abingdon, Oxon
United Kingdom

declares, that the product

Product Name: Power Analyzer

Model Number: PM300

conforms to the following Product Specifications

Safety: BS EN 61010 (1993)

EMC: BS EN 55022 (1995): Class A
BS EN 50082-2 (1992)

Supplementary Information: The product herewith complies with the requirements of the EMC Directives 89/336/EEC and 92/31/EEC and the Low Voltage Directive 73/23/EEC

Signed for on behalf of Voltech Instruments Ltd

Martin Whitley, Quality Manager

Abingdon, United Kingdom June, 1996

EMC PRECAUTIONS

Conducted and Radiated Emissions

The PM100 and PM300 comply with the limits of BS EN 55022 Class A.

To ensure continued compliance, the RS232 lead supplied for PC communications must be fitted with the ferrite at the analyzer end.

Any other RS232 or Parallel Printer leads used should have a ferrite fitted at the end of the lead closest to the analyzer.

Immunity

The PM100 and the PM300 may be susceptible to Fast Electrical Transients on the power line and Electrostatic Discharges, which can disrupt the operation of the units.

In the event of such an occurrence, to return the PM100 or PM300 to normal operation:

- 1) Switch off the power
- 2) Wait 5 seconds
- 3) Switch on again

