

USER'S HANDBOOK

Model 4600
Autocal Transconductance Amplifier

USER'S HANDBOOK

for

WAVETEK MODEL 4600 AUTOCAL TRANSCONDUCTANCE AMPLIFIER



This product complies with the requirements of the following European Community Directives:
89/336/EEC (Electromagnetic Compatibility) and 73/23/EEC (Low Voltage)
as amended by **93/68/EEC (CE Marking)**.

However, noisy or intense electromagnetic fields in the vicinity of the equipment can disturb the measurement circuit. Users should exercise caution and use appropriate connection and cabling configurations to avoid misleading results when making precision measurements in the presence of electromagnetic interference.

850243

Issue 1.1 (March 1995)

WAVETEK

ISO 9002

Wavetek Ltd

CERTIFICATE
No. FM 29700



For any assistance contact your nearest Wavetek Sales and Service Center.
Addresses can be found at the back of this handbook.

Due to our policy of continuously updating our products, this handbook may contain minor differences in specification, components and circuit design to the instrument actually supplied. Amendment sheets precisely matched to your instrument serial number are available on request.

© 1995 Wavetek Ltd

WAVETEK is a US registered trademark of Wavetek Corporation.

DANGER

INSTRUMENT DAMAGE

INPUT Terminals

This Instrument can be damaged by voltages in excess of 240V DC or RMS AC being applied continuously, or in excess of 1.1kV DC or RMS AC being applied for more than 10 seconds, across the INPUT terminals.

OUTPUT Terminals

Damage can result from the application of a common-mode voltage, in excess of 100V pk, between the I- terminal and the INPUT Ground terminal (Chassis).



INPUT terminals are sensitive to over-voltage

It can damage your instrument !

DO NOT EXCEED
the **INPUT** or **OUTPUT** terminal
specifications

DANGER

CONTENTS

SECTION 1 THE 4600 AUTOCAL TRANSCONDUCTANCE AMPLIFIER	
Introduction	1-1
General Description	1-1
Accessories	1-2
Additional Documentation	1-2
Principles of Operation	1-3
Fundamental Operating Modes	1-4
SECTION 2 INSTALLATION	
Unpacking and Inspection	2-1
Preparation for Operation	2-1
Connectors and Pin Designations	2-3
SECTION 3 USING THE 4600	
Front Panel Features	3-1
Rear Panel Features	3-2
Setting Up the 4600	3-3
Interconnections - General Guidelines	3-4
Slave Mode - Operating Routines	3-5
Slaved Facilities	3-9
Solo Mode - Operating Routines	3-10
Systems Application via the IEEE 488 Interface	3-12
SECTION 4 4600 SPECIFICATIONS AND VERIFICATION	
Specifications	4-1
Verification	
Introduction	4-3
4600 Solo Verification	4-4
Solo DC Current Verification	4-5
Solo AC Current Verification	4-9
4600 Slave Verification	4-12
Slave DC Current Verification	4-13
Slave AC Current Verification	4-17
Verification Report - 4600 RS 1	4600 RS 1-1
Appendices	
Appendix 1 - Validity Tolerance Limit Calculations	4-A1-1
Appendix 2 - Uncertainty and Traceability	4-A2-1
Appendix 3 - General Procedural Information	4-A3-1
Appendix 4 - Alternative AC Current Verification	4-A4-1
Appendix 5 - Harmonic Distortion Measurement	4-A5-1

SECTION 5 CALIBRATION

Routine Calibration	5-1
4600 Solo Calibration	5-4
Solo DC Current Calibration	5-5
Solo AC Current Calibration	5-9
4600 Slave Calibration	5-12
Slave DC Current Autocalibration	5-13
Slave AC Current Autocalibration	5-17

Appendix

Appendix 1 - Alternative AC Current Calibration	5-A1-1
---	--------

SECTION 6 FAULT DIAGNOSIS

6.1 Introduction	6-1
6.2 Diagnostic Guides	6-2
6.3 Fuse Protection	6-9

SECTION 7 DISMANTLING AND REASSEMBLY

7.1 General Precautions	7-1
7.2 General Mechanical Layout	7-1
7.3 Location and Access	7-2
7.4 General Access	7-3
7.5 Sub-Assembly Removal and Fitting	7-5

SECTION 8 SERVICING AND INTERNAL ADJUSTMENTS

8.1 Introduction and Servicing Categories	8-1
8.2 Cleaning the Air Intake Filter	8-3
8.3 Differential Amplifier - Common Mode Null and DC Offset Adjustment	8-4
8.4 Output Amplifier - Autobias Value Adjustment	8-6
8.5 SMPS Tuned Circuit - Faults and Optimization	8-8

SECTION 9 TECHNICAL DESCRIPTIONS

9.1 Principles of Operation	9.1-1
9.2 Analog Circuitry	9.2-1
9.3 Switch Mode Power Supply	9.3-1
9.4 Digital Circuitry	9.4-1
9.5 Power Supplies	9.5-1

Appendix

Appendix 1 - GALs U105, U204 and U206 - Transfer Functions	9-A1-1
--	--------

SECTION 10 SERVICING DIAGRAMS AND PARTS LISTS

This Section has its own Contents List.

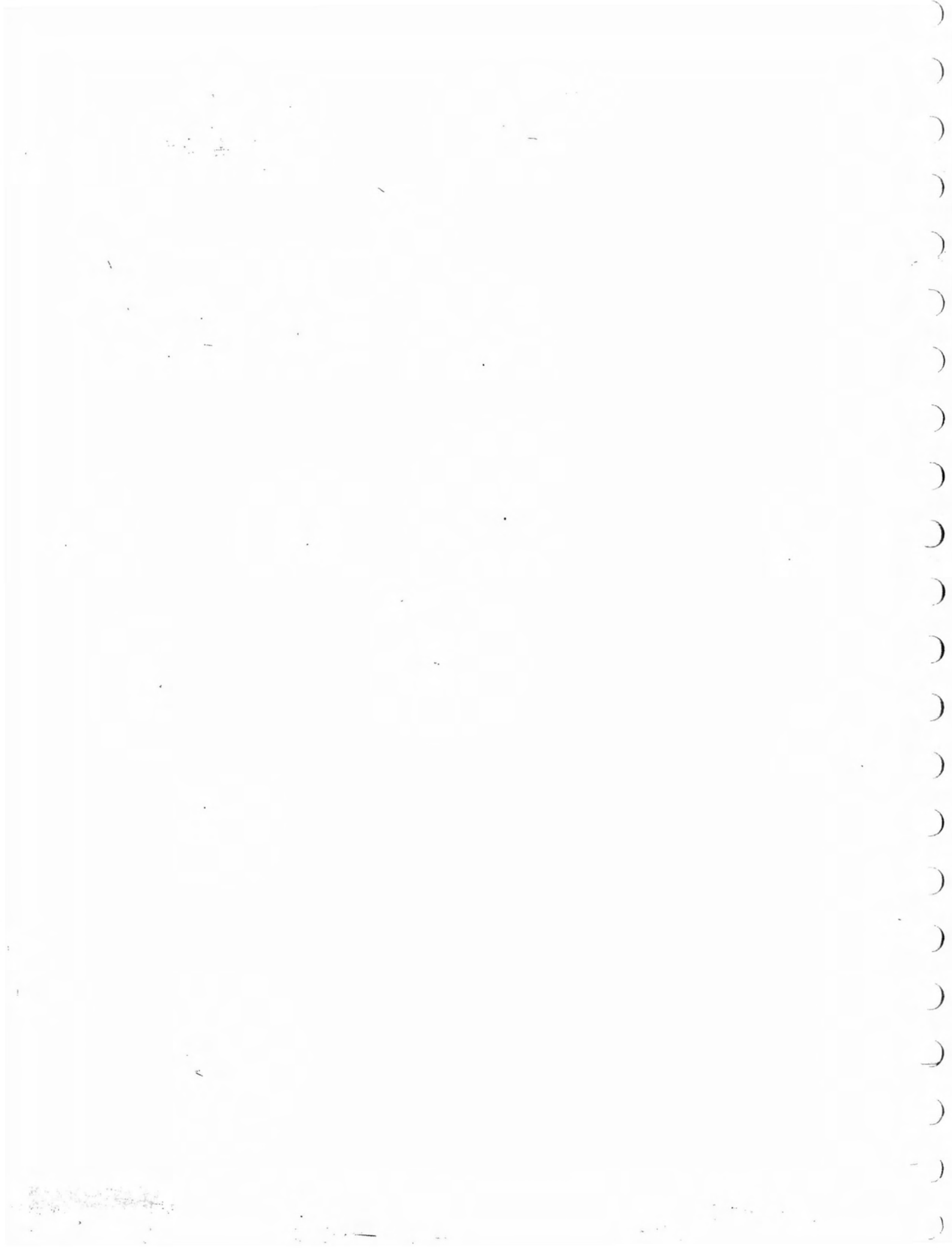

SECTION 1

The 4600 Autocal Transconductance Amplifier



Introduction

The 4600 complements the 4700 compatible series of calibrators, providing a means of increasing their range of DC and AC current outputs up to a maximum of 11 Amps. This enables the 4708, 4700 and 4705 calibrators to cover the full calibration requirements of many types of hand-held and bench-mounted digital multimeters.

Physically, the instrument is a separate unit which can be mounted on top of a calibrator, as shown in the photograph above. It can be used as a 'dumb' transconductance amplifier, taking as its reference the output from any voltage calibrator; but it reaches its full potential when slaved to a compatible 4700-series calibrator.

General Description

The 4600 is a compact, full-rack unit, which can be bench-mounted or fitted to a standard 19 inch rack. It converts an input reference voltage to an output current through a transconductance of 1 amp per volt.

It has two fundamental modes of operation: 'SLAVE', in which the 4600 and a compatible 4700-series calibrator are connected together to perform as a single integrated system; or 'SOLO', where the 4600 relies on the calibrator for only its input reference voltage. The 4600 cannot be used in Slave mode with the Datron 4000A or 4200A.

Accessories

The instrument is supplied with the following accessories:

Description	Part Number
Power Cable	920012
Hexagon Key 2mm A/F	630101
Hexagon Key 2.5mm A/F	630109
Power 2.5A Fuse (230V)	920209
Power 5.0A Fuse (115V)	920211
User's Handbook	850243

(The User's Handbook also contains the information which would normally appear in a Calibration and Servicing Handbook).

In addition, the following optional accessories are available for use with the 4600 instrument:

Description	Part Number
Rack Mounting Kit (Option 90)	440063
Current Output Lead Kit	440154
'Slave' Interconnector Kit	440151
1501 De Luxe Lead Kit	440070

Additional Documentation

This User's Handbook contains all information necessary to operate, calibrate and maintain the model 4600; including the 4700-series calibrator settings and connections when used in 'Slave' mode.

For use in 'Solo' mode, users should refer to the manufacturer's handbook for the operating instructions of the calibrator to be employed as voltage reference.

Principles of Operation

The simplified functional diagram in Fig. 1.1 shows how the instrument achieves its basic functions.

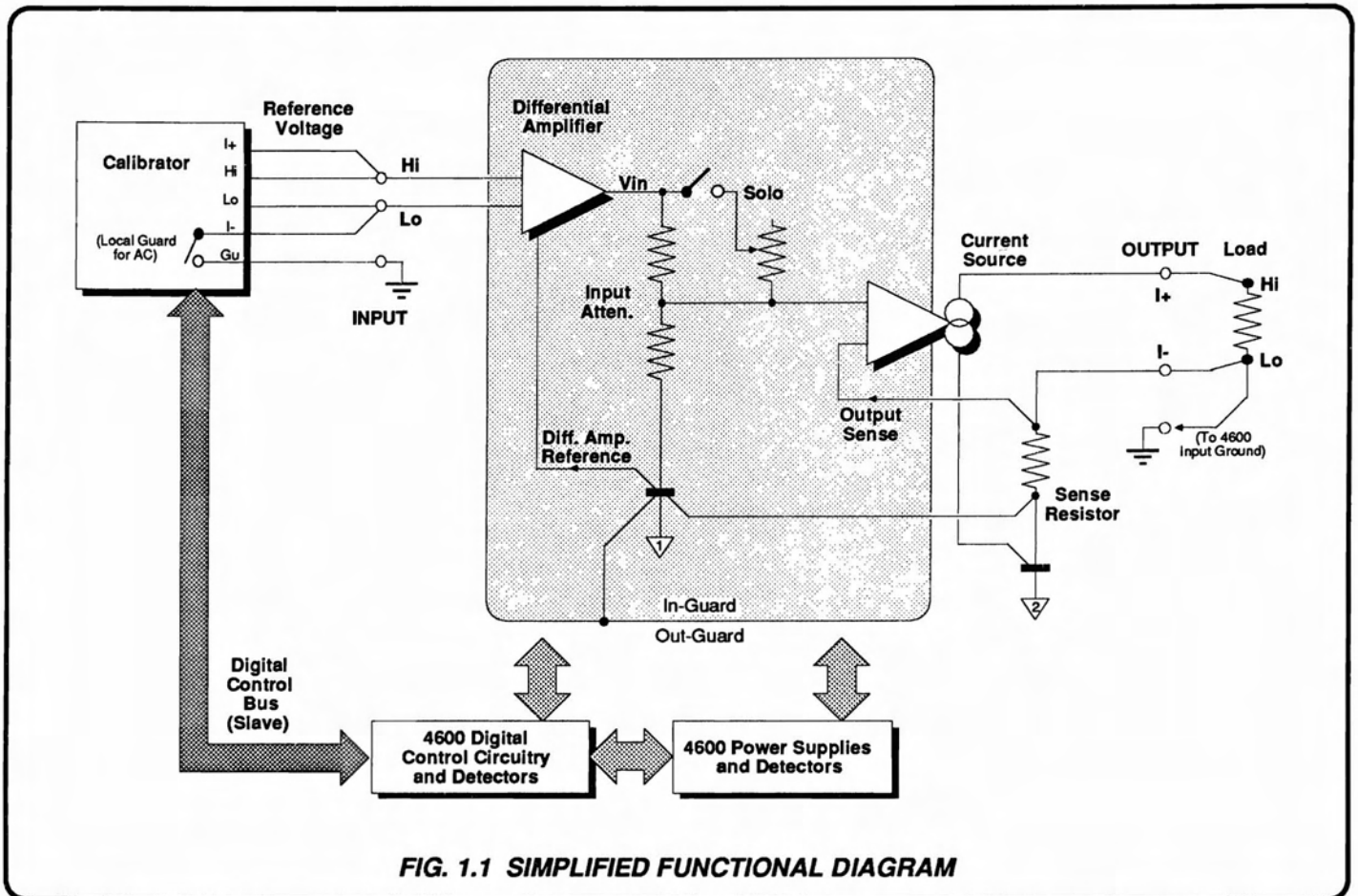

FIG. 1.1 SIMPLIFIED FUNCTIONAL DIAGRAM

Basics

DC Action

The DC Calibrator output voltage should be delivered via four-wire sensed connection; either to the two front panel INPUT terminals in Solo mode, or via the rear panel analog bus connector in Slave mode. Two-wire connection can be used in Solo mode, but the voltage arriving at the 4600 input terminals will be affected by the resistance of the connector leads.

The differential amplifier acts as a buffer to maximize common-mode rejection, the gain from the input terminals to the input of the voltage-to-current converter (Current Source) being controlled by the Input Attenuator and the differential amplifier gain. In Solo mode this is also affected by the trimpot in the attenuator.

The current output to the load is sensed by a series resistor. This takes all the load current, and provides the sense voltage which feeds back negatively to control the transconductance of the Current Source.

When calibrating a high-current range of a digital multimeter, the load would be an internal shunt which the multimeter uses to sense its input current - typically of the order of 10mΩ.

AC Action

The basic action remains the same as for DC, but the effects of frequency need to be taken into account. When a high AC Current is being delivered to a load, the self-inductance of the output leads takes on greater significance - some 1μH for a typical single lead of, say, 30mΩ resistance. So for 10A at 5kHz the RMS voltage across a single lead can exceed 0.4V.

To minimize the common-mode voltage presented to the load, an external connection needs to be made between load Lo and 4600 ground. This transfers the voltage into the 4600 at common-2, removing the problem from the load. The common-mode voltage also appears at common-1, and on all of the 4600 analog circuit. The Load Lo/Input Ground lead also improves DC operation.

The effect is to present an equivalent common-mode voltage at the INPUT Lo terminal, but the differential amplifier is designed to reject common mode at its input by a ratio of 80dB minimum, and provided that the calibrator is placed in Local Guard, with its Guard connected to the 4600 Ground, common-mode transfer to the calibrator is avoided. The effects of the common-mode on the sensitive circuits of the 4600 are guarded out.

Fundamental Operating Modes

(In the following text, '4700' represents any of the three models in the range: 4700, 4705 or 4708).

SLAVE Mode

Interconnections (See diagrams in Section 2)

Two interconnecting cables are required to link the 4600 to a 4700-series calibrator. The optional-accessory lead kit (Part Number 440151) provides these two connectors:

- A special shielded 6-way LEMO cable transfers the reference voltage from the 4700 rear panel J56 to the 4600 rear panel J66, one line being an 'Analog Bus On' link.
- A 15-way D-type connector provides the necessary digital control lines between 4700 rear panel J54 and 4600 rear panel J54. This includes a 'Digital Bus On' link.

If either of the two 4600/4700 connectors is not present, the 4600 reverts to 'Solo' mode, and the message 'Error 9' appears on the 4700 Mode display when its 10A range is selected.

The current output lead kit (optional accessory - Part No. 440154) can be used for connection from the 4600 OUTPUT terminals to the current output load. A single 'banana' lead is required to connect the load Lo to the 4600 INPUT Ground terminal.

Analog Operation

The 4700's 10A range key is enabled, generating a reference voltage between 0V and 11V, at the analog output connector on its rear panel. This voltage is fed via the special 6-way cable into a connector on the rear panel of the 4600, to be converted into a current which passes out of the 4600 front panel I+ and I- OUTPUT terminals. The normal 4700 output terminals are isolated when the 10A range is selected (and vice-versa).

Local Control (Refer to Section 3)

The 4600 is activated from the 4700 front panel. This is done by selecting either DC or AC, and FUNCTION I, with RANGE 10, the 4600 output current being adjusted by operating the 4700 OUTPUT ↑ ↓ keys.

Slave mode allows the 4600 output to be switched on and off using the appropriate 4700 front-panel keys, but does not prevent the 4600 front panel keys being used for the same purpose. Control is transferred to the 4600 using digital signals, which are carried between the two units by the D-type connector cable.

Note that if either the control or analog connector is removed, the 4600 automatically defaults to Solo mode.

Remote Control via the IEEE 488 Interface

(Refer to Section 3)

When the 4700 is programmed into DCI or ACI function, it responds to IEEE 488 bus command R6 to call up the 10A range, which operates in exactly the same manner as described above for manual control.

Calibration (Refer to Section 5)

The entire AUTOCAL operation is controlled from the 4700, all the calibration constants being stored within the 4700 non-volatile calibration memory. Subsequently, these constants do not affect the gain of the 4600 internal circuitry, but modify the value of the reference voltage being fed from the 4700 via the analog cable to the 4600. The 4600 should therefore be slaved only to the individual 4700 which holds its calibration constants, otherwise invalid corrections will be applied. A label on the front of the instrument identifies the serial number of the 4700-series calibrator with which the 4600 was calibrated in Slave mode at manufacture.

Self Test (Refer to Sections 3 and 6)

Pressing the Test key on the 4700 automatically checks both the 4700 and the 4600. This is additional to the 4600's normal testing, which includes continuous monitoring for catastrophic failures (such as power supplies), overload (overcompliance), input overdrive and overtemperature. These conditions are reported on the 4700 display as well as by the indicator LEDs on the 4600 front panel. Output turns Off when appropriate.

Specification Readout (Refer to Section 3)

The specification and calibration uncertainties, associated with an individual 4600, are held in the non-volatile memory of the individual 4700 with which it was calibrated. Spec mode on that 4700 retrieves and displays the appropriate uncertainties associated with the 10A range when connected to that 4600.

SOLO Mode

Interconnections (Refer to Section 2)

The current output lead kit (optional accessory - Part Number 440154) can be used for connection from the 4600 to the current output load.

Analog Operation

The reference voltage is fed into Hi and Lo INPUT terminals on the front of the 4600, to be converted into a current which passes out of the 4600 front panel I+ and I- OUTPUT terminals. The transfer characteristic is 1 amp per volt.

Local Control (Refer to Section 3)

The 4600 output is controlled by the value of its input voltage, its output being switched On and Off by its own front-panel keys.

No Remote Control

No provision is made for remote operation in Solo mode. For programmable remote operation, it should be connected in Slave mode to a compatible 4700-series calibrator.

Calibration (Refer to Section 5)

This is achieved by simple mechanical adjustments of internal trim pots and trimmer capacitors. These are used instead of Autocal corrections only when the 4600 is not slaved to a compatible 4700 series calibrator, being bypassed in Slave mode.

Self Test (Refer to Section 3)

Error conditions such as overload (overcompliance), input overdrive and overtemperature are reported by the indicator LEDs on the 4600 front panel. All error conditions cause the Output to turn Off.

SECTION 2

Installation

This section contains information and instructions for unpacking and installing the Datron 4600 Autocal Transconductance Amplifier. The layouts of the instrument front and rear panels can be found in Section 3.

Unpacking and Inspection

Every care is taken in the choice of packing material to ensure that your equipment will reach you in perfect condition. If the equipment has been subject to excessive handling in transit, the fact will probably be visible as external damage to the shipping carton. In the event of damage, the shipping container and cushioning material should be kept for the carrier's inspection.

Unpack the equipment and check for external damage to the case, sockets, keys etc. If damage is found notify the carrier and your sales representative immediately.

Standard accessories supplied with the instrument should be as described in Section 1.

Preparation for Operation

Power Input

The recessed **POWER INPUT** plug, **POWER FUSE** and **LINE VOLTAGE SELECTOR** are contained in an integral module on the rear panel.

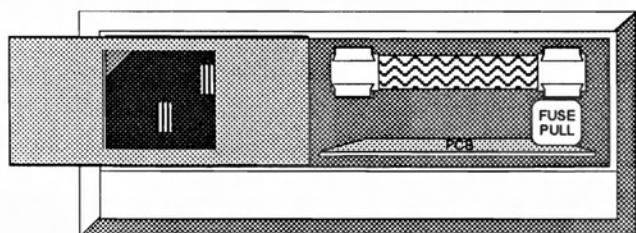

The protective window allows the fuse rating and line voltage selector to be inspected with the power cable connected. This window slides to the left once the cable socket has been disconnected, for access to the fuse and voltage selector printed circuit board.

Power Cable

The detachable supply cable comprises two metres of 3-core PVC sheath cable permanently moulded to a fully-shrouded 3-pin cable socket. It fits into the **POWER INPUT** plug recess, and should be pushed firmly home.

The supply lead should be connected to a grounded outlet ensuring that the Ground lead is connected. Connect Brown lead to Line, Blue lead to Neutral, and Green/Yellow lead to Ground.

Line Voltage

The 4600 is operative within the line voltage ranges 100/120/220/240 volts $\pm 10\%$, at 50Hz or 60Hz. To accommodate the ranges, a small selector PC board is housed beneath the **POWER FUSE**.

To Reselect the Operating Voltage

- **FIRST** ensure that the **POWER CABLE** is removed.
- Slide the window to the left to reveal the fuse and voltage selector PCB.
- Draw the fuse extractor to the left, and remove the fuse.
- Remove the selector PCB and rotate it until the desired voltage is presented on the left of the upper surface.

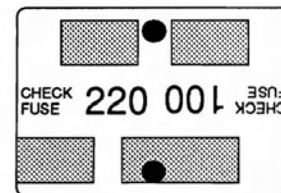
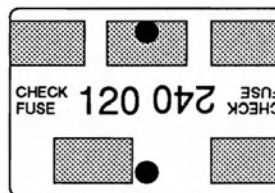

- Re-insert the selector PCB firmly into the module slot. The desired voltage is visible in the cutout below the fuse.
- Return the fuse extractor to the normal position.
- Insert the appropriate **POWER FUSE** (see below).
- Slide the window to the right and insert the **POWER CABLE**.

Power Fuse

The fuse is located behind the window in the **POWER INPUT** module on the rear panel. It should be of the 'fastblow' type. Its rating is dependent on the supply voltage:

for 200/260V line supply - 2.5A,
for 100/130V line supply - 5.0A.

MAKE SURE THAT ONLY FUSES WITH THE REQUIRED RATED CURRENT AND OF THE SPECIFIED TYPE ARE INSERTED AS REPLACEMENTS.

AVOID THE USE OF MENDED FUSES AND DO NOT SHORT-CIRCUIT THE FUSE HOLDER. SUCH PRACTICES WILL RENDER THE WARRANTY VOID.

Preparation for Operation (contd.)

Mounting

Bench Mounting

The instrument is fitted with rubber-soled plastic feet. It is intended to stand flat on a bench or on top of a 4700-series calibrator, positioned so that the cooling-air inlet and exhaust apertures are not obstructed. It is recommended that at least 30cm (12 inches) of free space is at the rear.

Rack Mounting

Option 90 permits the instrument to be mounted in a standard 19 inch rack. The method of fitting this option is described below.

N.B. The top or bottom cover should not be removed for this purpose.

Procedure

1. Remove the handles, if fitted, by loosening the hexagonal screws of the handle assembly and sliding the assembly to the rear until free of the instrument.
2. Slot the rack mounting 'ears' into the guides at each side of the instrument, from the rear.
3. Draw the ears forward until positioned correctly. Tighten the hexagonal screws, using the hexagonal key provided.

It is recommended that the rear of the instrument be supported in the rack.

Connectors and Pin Designations

Front Terminals

Input Terminals

Three 4mm 'banana' terminals are fitted in the INPUT field on the left of the front panel. Their functions are as follows:

Hi	Voltage Input - High
Lo	Voltage Input - Low
	Input Ground

Output Terminals

Two 4mm 'banana' terminals are fitted in the OUTPUT field of the front panel. Their functions are as follows:

I+	Current Output Source
I-	Current Output Sink

J54 Slave Digital Connector (rear panel)

A 15-way cable provides the necessary digital control lines between J54 on the rear panel of the 4700-series calibrator and J54 on the 4600 rear panel. The cable (also part of optional accessory lead kit: part no. 440151) is terminated at each end by a D-type connector. At the 4600 end the cable socket is secured to the rear panel plug by two screws. Pin 9 carries the IDIGBUSON_H signal, which indicates if the cable is disconnected at either end, informing the 4600 that the connection is broken.

Pin Layout Pin Designation

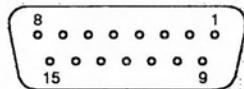

Pin	Name	Function
1	SHIELD	Case Ground
2	0V_6	Digital Common
3	IWR_R	Write Strobe (Rising Edge)
4	0V_6	Digital Common
5	0V_6	Digital Common
6	ICAL_RST_L	Not used on 4600
7	IA_H_D_L	Address/Data on AD0-AD4
8	JRD_L	Read Strobe (Active Low)
9	IDIGBUSON_H	+5V (5k) when 4700 is on.
10	0V_6	Digital Common
11	IAD0	Bi-directional Address/Data Lines, controlled by Strobes and IA_H_D_L
12	IAD1	
13	IAD2	
14	IAD3	
15	IAD4	

J66 Slave Analog Connector (rear panel)

When slaved to a 4700-series calibrator, a 6-way 'LEMO' cable transfers the reference voltage from J56 on the calibrator rear panel to J66 on the 4600 rear panel.

This provides a guarded 4-wire connection to deliver and sense the calibrator's output voltage at the 4600 input. One wire carries the ANABUSON_L signal, which reverts to high if the cable is disconnected at either end, informing the 4600 that the connection is broken.

Two keyways locate the cable connector socket into J66, and a red spot on the cable should be lined up with a similar spot on the 4600 rear panel plug. Once located, the cable is secured by pushing the socket firmly home into the rear panel plug. It is removed by sliding the knurled ferrule away from the plug to release the securing mechanism, then continuing to pull to remove the socket.

Pin Layout and Designations

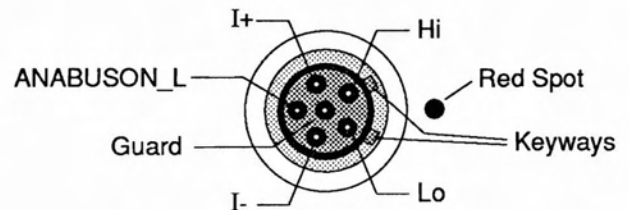

Slave Connector Kit (optional accessory)

A kit of two cables provides the slaving connections between a compatible 4700-series calibrator and the 4600.

The Datron Part no. for the kit is 440151, comprising:

Connector	Calibrator End	4600 End
Digital Bus (15-way)	Shrouded D-type plug, fitting J54 socket.	Shrouded D-type socket, fitting J54 plug.
Analog Bus (6-way)	Push-fit LEMO plug, fitting J56 socket.	Push-fit LEMO plug, fitting J66 socket.

SECTION 3

Using the 4600

Front Panel Features

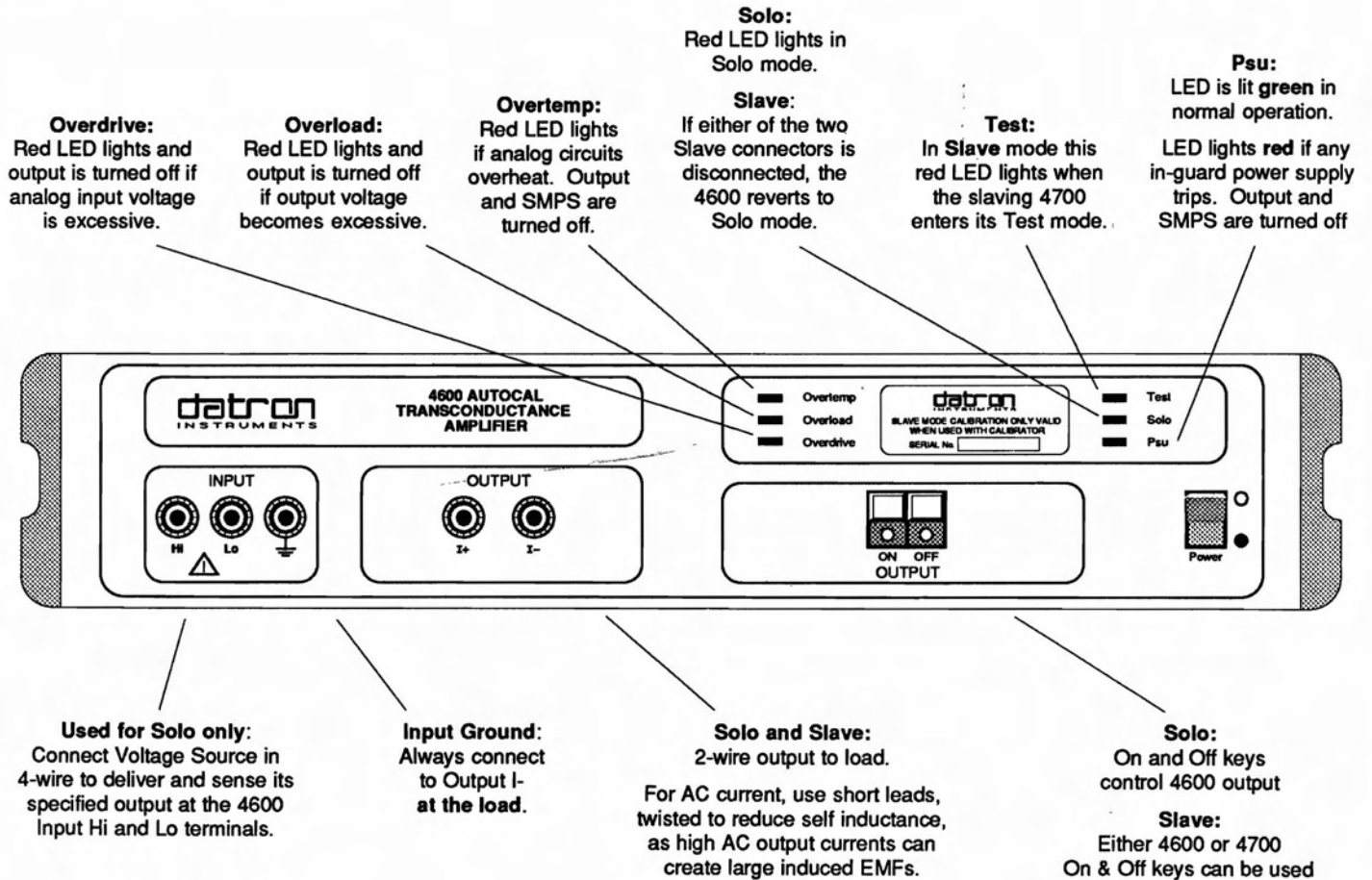

Rear Panel Features

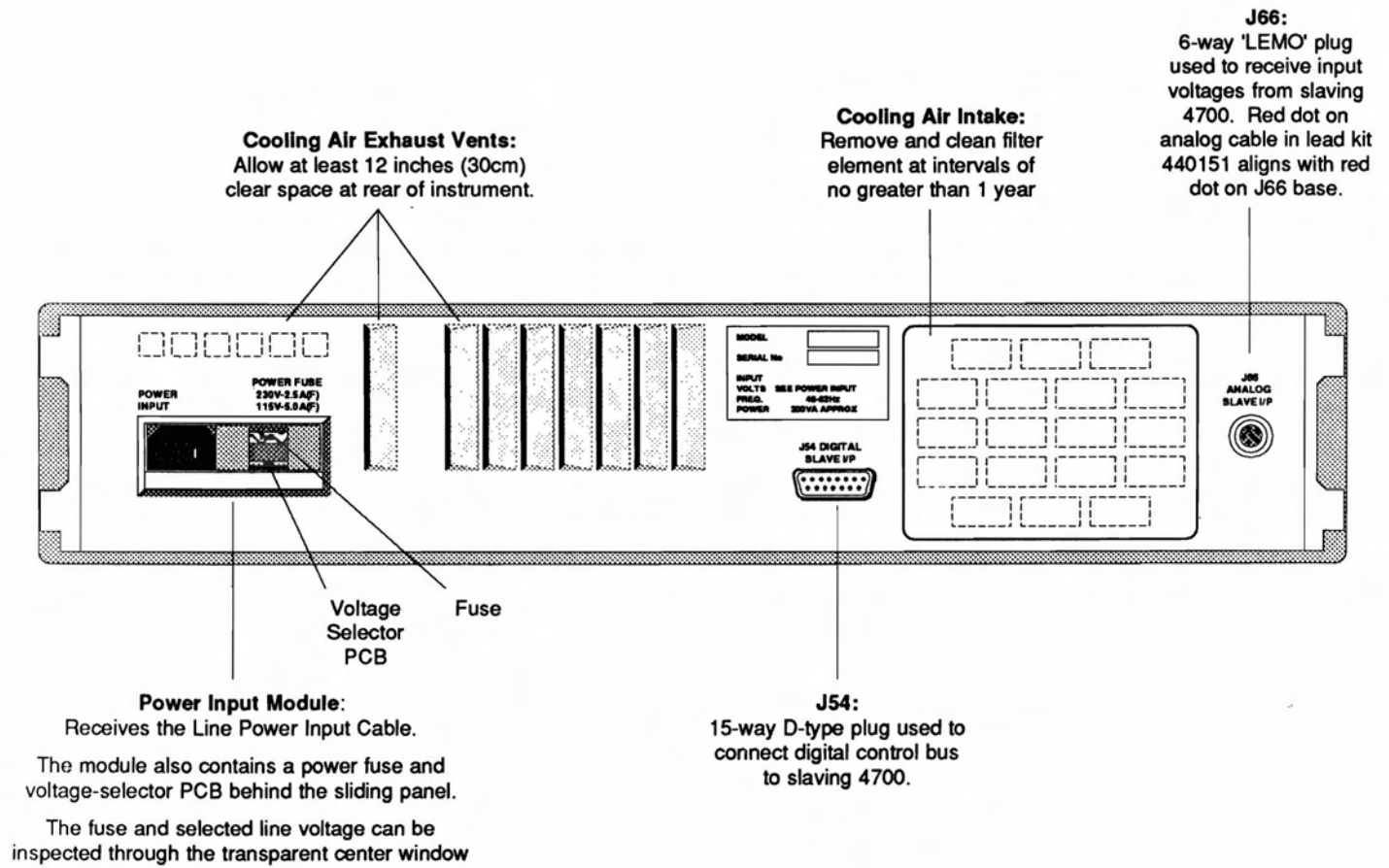

Setting Up the 4600

Introduction

The 4600 increases the range of DC and AC current outputs of 4700-series calibrators up to a maximum of 11 Amps, or adds a nominal 10A range to other DC or AC voltage calibrators, converting an input reference voltage to an output current through a transconductance of 1 amp per volt.

It has two fundamental modes of operation: 'SLAVE', in which the 4600 and a compatible 4700-series calibrator (with Option 20 and firmware issue 5 or above) are connected together to perform as a single integrated system; or 'SOLO', where the 4600 is controlled mainly from its own front panel, relying on a calibrator only for its input reference voltage.

N.B. Compatible 4700-series calibrators are:
 Models: **4700, 4707, 4708**
 (with Option 20 and firmware issue 5 or above),
 or Model: **4705**
 (with firmware issue 5 or above).

For the sake of brevity, these are sometimes referred to as '4700' in this handbook.

Preliminaries

Before using the instrument it is important that it has been correctly installed as detailed in Section 2.

Limiting Characteristics

The following details are given in Section 4:

Operating and Storage Temperatures
 Peak Terminal Voltages
 Settling Times

Safety

The 4600 is designed to be Class 1 equipment as defined in IEC Publication 348, and UL 1244, concerning safety requirements.

Protection is provided by a direct connection via the power cable from ground to exposed metal parts and internal ground screens.

The line connection must only be inserted in a socket outlet provided with a protective ground contact, and continuity of the ground conductor must be assured between the socket and the instrument.

WARNING:

ANY INTERRUPTION OF THE PROTECTIVE GROUND CONDUCTOR INSIDE OR OUTSIDE THE INSTRUMENT, OR DISCONNECTION OF THE PROTECTIVE GROUND TERMINAL, MAY MAKE THE APPARATUS DANGEROUS. INTENTIONAL INTERRUPTION IS PROHIBITED.

CAUTION:

THE \triangle SYMBOL IS PLACED ADJACENT TO TERMINALS THAT ARE SENSITIVE TO OVERVOLTAGE CONDITIONS. IT IS USED TO REMIND THE USER OF THIS SPECIAL PRECAUTION.

REFER TO SECTION 6.

Interconnections - General Guidelines

Importance of Correct Connections

When calibrated, the 4600 is capable of providing very high traceable accuracy. To attain this performance, it is necessary to match the external circuitry to its superior specification. To ensure that external connections are made correctly, a few general guidelines are given in the following paragraphs.

Sources of Error

Thermal EMFs

These can give rise to series (Normal) mode interference, particularly where large currents have a heating effect at thermoelectric junctions. In otherwise thermoelectrically-balanced measuring circuits, cooling caused by draughts can upset the balance.

E-M Interference

Noisy or intense electric, magnetic and electromagnetic effects in the vicinity can disturb the measurement circuit. Some typical sources are:

- Proximity of large static electric fields.
- Fluorescent lighting.
- Inadequate screening, filtering or grounding of power lines.
- Transients from local switching.
- Induction and radiation fields of local E-M transmitters.
- Excessive common mode voltages between source and load.

The disturbances can be magnified by the user's hand capacitance. Electrical interference has greatest effect in high impedance circuits. Separation of leads and creation of loops in the circuit can intensify the disturbances.

Lead Resistance and Inductance

The resistance of the connecting leads can drop significant voltages between the source and load, especially at high load currents. AC high-current circuits are particularly prone to the effects of lead inductive reactance.

Lead Insulation Leakage

This can cause significant errors in measurement circuits at high voltages. Some insulating materials suffer greater losses than others, e.g. PVC has more leakage than PTFE.

Avoidance Tactics

Thermal EMFs:

- Screen thermal junctions from draughts.
- Allow time for thermal equilibrium to be reached before taking readings.
- Use conductors, joints and terminals with a good margin of current-carrying capacity.
- Avoid thermoelectric junctions where possible:
 - Use untinned single-strand copper wire of high purity.
 - Avoid making connections through Nickel, Tin, Brass and Aluminium. If oxidation is a problem use gold-plated copper terminals, and replace the terminals before the plating wears off.
 - If joints must be soldered, low-thermal solders are available, but crimped joints are preferred.
- Use low-thermal switches and relays where they form part of the measuring circuit.
- Balance one thermal EMF against another in opposition, where possible. (Switch and relay contacts, terminals etc.)

E-M Interference:

- Choose as "quiet" a site as possible (a screened cage may be necessary if interference is heavy). Suppress as many sources as possible.
- Always keep interconnecting leads as short as possible, especially unscreened lengths.
- Run leads together as twisted pairs in a common screen to reduce loop pick-up area, but beware of leakage problems and excessive capacitance.
- Where both source and load are floating, connect Lo to ground at the source to reduce common mode voltages.

Lead Resistance:

- Keep all leads as short as possible.
- Use conductors with a good margin of current-carrying capacity.
- Use Remote Guard or 4-wire connections where necessary.

Lead Inductance:

- Keep all leads as short as possible.
- Use special connections where necessary.

Lead Insulation Leakage:

Choose low loss insulated leads - PTFE is preferred to PVC. When running leads together in screened pairs, avoid large voltages between leads in the same screen, especially if using PVC insulation.

Slave Mode - Operating Routines

In this text, '4700' represents any compatible model in the range: 4700, 4705, 4707 or 4708, equipped with firmware of issue 5 or greater. (A 4700 must be fitted with Option 20; a 4707 with Option 27.)

(The 4708 needs Option 30, with Option 10 for DC Current, and/or Option 20 for AC Current.)

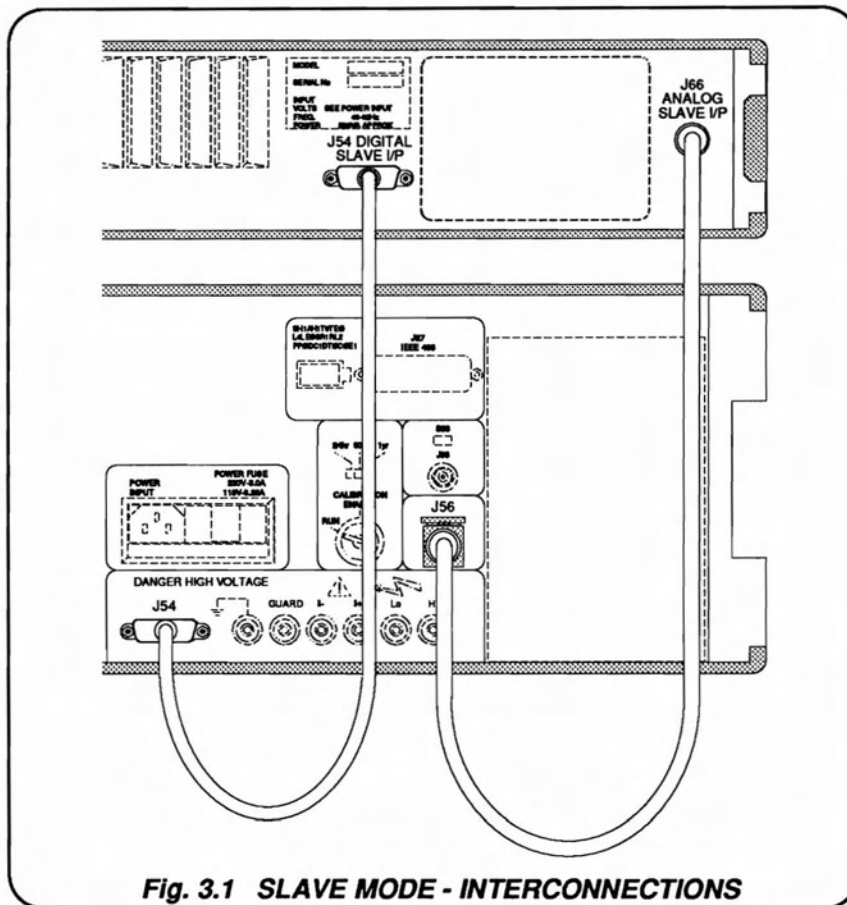

Fig. 3.1 SLAVE MODE - INTERCONNECTIONS

Interconnections

The 4600 should be linked to a 4700-series calibrator as shown in Fig. 3.1. If either the digital or analog cable is not correctly connected, the 4600 will operate in 'Solo' mode. For the purposes of this description it is assumed that the two connectors from the optional-accessory lead kit (Part Number 440151) provide the linkage.

It is also assumed that the current output lead kit (optional accessory - Part Number 440154) is used for connection from the 4600 OUTPUT terminals to the current output load. For AC Current outputs, a lead connects the load L_o to the 4600 INPUT Ground terminal (refer to the description of basic operation in Section 1, page 1-3).

If either of the two 4600/4700 connectors is not present, the 4600 reverts to 'Solo' mode, and the message 'Error 9' appears on the 4700 MODE/FREQUENCY display when its 10A range is selected.

Analog Bussing

Ensure that the 4700 and 4600 are linked as shown in Fig. 3.1. It is also possible to interlink the Current output terminals of the two instruments in parallel, as the firmware isolates one output when the other is selected. Thus a single output analog bus can be set up, to which the outputs of the integrated system appear to derive

from a single instrument. This facility is most useful when operating in remote control via the IEEE 488 interface, but remember to keep the leads short.

4700 Guard and Sense

Note that the operation of the 4600, in slaved mode, is designed to be transparent to an operator once the external connections have been made. The firmware maintains the appearance (to the operator) of the 4700 being used in just another Current range, even though the 4700 is feeding a reference voltage to the 4600. Thus when slaved, the operator has no control over the Guard and Sense connections between the two instruments, these are auto-selected for optimal performance by the 4700 firmware.

Calibration Corrections

In Slaved mode, the 4600 internal calibration adjustments are inhibited. The output Current is corrected by automatic adjustment of the Reference voltage from the 4700, due to factors stored in the 4700's non-volatile calibration memory. These factors were derived at the most-recent calibration of the 4600 with that individual 4700.

Slave Mode calibration procedures are given in Section 5.

First ensure that the 4700 and 4600 have been powered ON and warmed up for at least 1 hour, then use the following sequence to set up the slaved operation, from ① to ⑪:

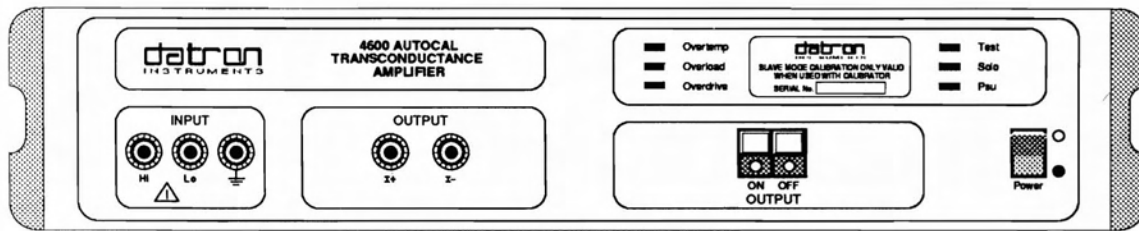

AC Current only

⑥ Connect Load Lo to INPUT Ground

④ Select Required FREQUENCY RANGE (or Spot Frequency on 4708 only)

⑤ Use ↑ ↓ keys to adjust FREQUENCY display (not for spot)

⑦ Connect Load to OUTPUT Terminals

⑧ Select OUTPUT RANGE 10

⑨ Use ↑ ↓ keys to adjust OUTPUT display

⑩ A single keypress obtains Zero or Full Range

⑪ To energize 4600 output, Select either 4600 or 4700 OUTPUT ON

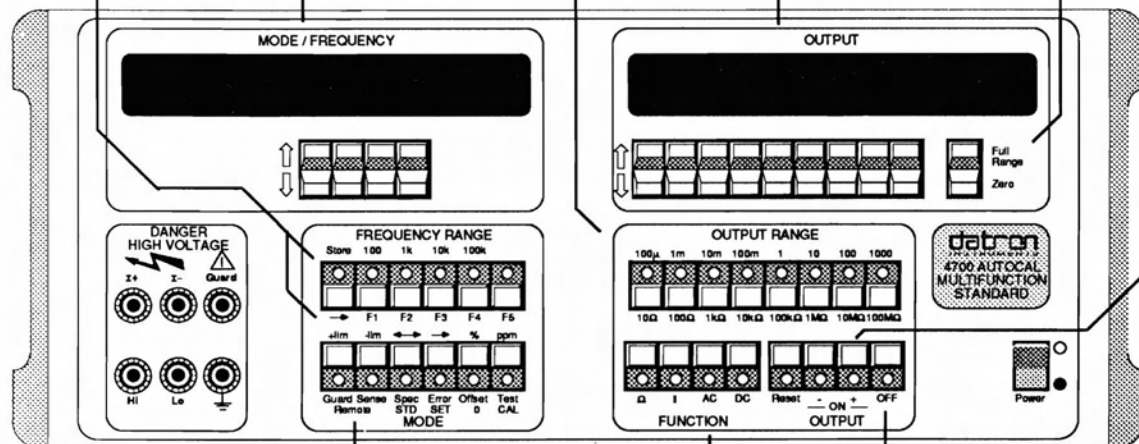

Guard and Sense are auto-selected. No user-action required

③ Select either DC or AC, then function I

② Ensure OFF LED is LIT

① Ensure Rear-Panel connections are correct

* To set Output Off, press the OUTPUT OFF key, either on the 4600 or on the 4700.

Fig. 3.2 GENERAL SEQUENCE OF OPERATIONS - SLAVE MODE

Operating Routines - Slave Mode

Power Switches

Ensure that both 4700 and 4600 Power switches are set to ON, and both instruments have warmed up for at least 1 hour.

DC Current Output

Use the General Sequence in Fig. 3.2. Modify selections as follows:

- At operation [3] first select **DC** and then **I**,
- Omit operations [4], [5] and [6],
- Use operations [7] to [11] and [2] as required.

N.B. For full specification, output compliance should be limited to 2V RMS.

AC Current Output

Use the General Sequence in Fig. 3.2. Modify selections as follows:

- At operation [3] first select **AC** and then **I**,
- Use operations [7] to [11] and [2] as required.

N.B. For full specification, output compliance should be limited to 2V RMS.

Spot Frequencies

When slaved to the 4708, Spot Frequencies can be selected and calibrated. The 4600 behaves as an extension to the 4708; so the procedures for selection and calibration (with or without the SET function) are as described in the 4708 Handbooks.

Current Output On/Off

Once slaved to the 4700, the 4600 Current output can be turned on and off from either the 4600 or 4700. All On/Off actions are sequenced by the 4600 and 4700 firmware to maintain a safe internal environment, and are thus subject to small delays, except when responding to emergency conditions.

4700 Current Range Changing

If the 4700 output is On in one of its normal Current ranges when the 10A range key is pressed, the 4600 Current output is turned On and the 4700 output is turned Off and isolated. Conversely, when ranging the 4700 down from the 10A range, the 4600 output is turned Off and isolated as the 4700 output is turned On.

Full Range Output

The calibration-corrected full range output of the 4600 (10A DC or RMS) can be obtained by pressing the Full Range key on the 4700 front panel.

Zero Output

For DC Current the 4600 output value can be incremented continuously through zero, using the 4700 OUTPUT display $\uparrow\downarrow$ keys. Zero can also be obtained by pressing the 4700 Zero key, which causes the internal firmware to isolate the 4600 I+ and I- terminals from the internal circuitry, physically interrupting the output current.

For AC Current the 4600 output value cannot be incremented continuously through zero, as the smallest output on the range is 900mA (9% FR). Zero can **only** be obtained by pressing the 4700 Zero key, the results being the same as for DC.

AC Increment from Zero

Because the smallest output is 9% FR, the minimum increment from Zero is 10%. Half-size zeros on the 4700 OUTPUT display show which keys cannot be used to increment from Zero; the full-size zero shows the key which can.

4700 Zero Display for the 1A Range

The appearance of the 4700 OUTPUT display for Zero 4600 output (10A range) follows the form used for the other 4700 Current ranges:

Range	Zero Display
10A	0.000,00

AC Frequency Control

For AC outputs, the frequency of the 4600 is set by the frequency of the Reference voltage being applied from the 4700. Thus adjustments are carried out from the 4700 using its FREQUENCY RANGE keys, and FREQUENCY display $\uparrow\downarrow$ keys, with autorange operating as for the 4700. The procedure is identical to that described in the 4700 User's Handbook, Section 3; except that the 4600 full frequency span is extended to 20kHz.

Error Indications

The presence of an error initiates the OFF sequence, and a 4600 front panel LED indicates the type of error. The 4700 is programmed to read back status information continuously via the digital interface. In the event of an error occurring, the 4700 turns off the analog output to the 4600 and generates a message on its own MODE/FREQUENCY display. A list of Warnings and Messages relating to the 4700 appears at the end of Section 4 in the 4700 User's Handbook. Some of these can also apply to the 4600. These are listed overleaf, and are further analyzed in Section 6 (Fault Diagnosis).

Special Slaved 4600 Warnings and Messages

4700 FREQUENCY/MODE display

N.B. If the displayed message applies only to the 4600, then the error or failure will also be reported via the 4600 front panel LEDs. The following are typical examples, for further information refer to Section 6:

- Error 1 to Error 6** - Same meanings as for the 4700.
- Error 7** - Not applicable to the 4600.
- Error 8** - The 4600 is not turned on or faulty at the point of selecting the 4700 10A range. See 'FAIL 10'.
- Error 8** - 4600 **Solo** LED lit - One of the two interconnecting bus cables is not connected or faulty. Error 8 occurs at the point of selecting the 4700 10A range. See 'FAIL 10'.
- Error 9** - Not used for the 4600, but will occur if the 4700 Current option is not fitted.
- Error OL** - 4600 **Overdrive** LED lit - The Input Voltage to the 4600 is too high. Check the 4700 OUTPUT setting.
- Error OL** - 4600 **Overload** LED lit - The terminal voltage has been compliance-limited to: 2V (10A range), so the input impedance of the load is probably too high.
- FAIL 1** - 4600 **Overtemp** LED lit - The 4600 has overheated and has shut down. One minute after the temperature has returned to normal, the 4700 and 4600 will be reactivated.
- FAIL 2 to FAIL 8** - Related to 4700 internal operations.
- FAIL 9** - 4600 **Psu** LED red - A 4600 Power Supply failure has occurred, output has been turned off and the 4600 has shut down.
- FAIL 10** - The 4600 has been turned off or become faulty while the 4700 10A range was selected. See 'Error 8'.
- FAIL 10** - 4600 **Solo** LED lit - One of the two interconnecting bus cables has become disconnected or faulty. FAIL 10 only occurs once the 4700 10A range has been successfully selected. See 'Error 8'.

Slaved Facilities

Inherent 4600 Facilities

On/Off Switching

The slaved 4600 output can be turned on and off from its front panel push-buttons. The on/off state is reported via the digital bus, and the slaving 4700 output on/off controls can be used as duplicates. Because the polarity of the 4600 DC output current is determined by the polarity of its input voltage from the slaving 4700, there is no facility for changing 4600 output polarity on its own front panel.

Status Checking

The 4600 continuously monitors its own analog operation, reporting failures and errors via its front panel LEDs. Its operational status is also made available for monitoring by the slaving 4700.

4600 Facilities Slaved by the 4700

Output Value and DC Polarity

Because the 4600 is just a transconductance amplifier, its current output is a function of the instantaneous values of its input voltage. Thus its output value can only be controlled directly from the slaving 4700. This includes its DC output polarity, which therefore depends on the state of the 4700 ON+/ON- switching, and the polarity shown on the 4700 OUTPUT DISPLAY.

Frequency Store

The 4700 firmware allows frequencies to be stored for use with the 4600 output. The procedure and effect is the same as for the 4700, bearing in mind that the 4600 frequency span is extended to 20kHz. To avoid continual reference to the 4700 User's Handbook, Section 4; the operations are summarized below:

4700 Store Key - Summary

Press and Release:

Accesses F1-F5 for stored-frequency retrieval.

Second Press and Release:

Deselects Store to revert to normal frequency facility.

Press and Hold:

Allows the displayed frequency to be stored by pressing and releasing the F1-F5 key of the required memory, while holding the Store key pressed. Releasing the Store key leaves the chosen frequency active, and present on the 4700 FREQUENCY display.

Spec Mode

The 4700 Spec mode is extended to cover the uncertainties which affect the 4600 output, operating as if its 10A range were a 4700 range. The figures appearing on the 4700 MODE display include the 4600 and 4700 instrument specification uncertainties (related to the setting of the Calibration Interval switch on the 4700 rear panel); and Datron's calibration uncertainties relative to National Standards. They are held in non-volatile memory within the 4700,

along with the calibration corrections which affect the value of the Reference voltage to be applied to the 4600 input. Thus if a 4600 is slaved to a 4700 with which it was not calibrated, incorrect calibration corrections and Spec mode uncertainties will result.

The use of the Spec key to display the stored figures is described in Section 4 of the 4700 User's Handbook.

Error and Offset Modes

Because the value of the Reference voltage applied to the 4600 is controlled by the internal programming of the 4700; all the facilities which are available in the 4700 Current ranges can be (and are) extended to the 4600 10A range, through this medium. For DC outputs, both Error and Offset modes are available; and for AC outputs, Error mode only can be used. This reflects the normal situation which applies to the Current ranges of the 4700. Thus, for Error and Offset mode operation of the 4600, the separate and combined uses of the Error and Offset keys for the 4600 output conform to the descriptions in Section 4 of the 4700 User's Handbook.

Reset

The 4600 is reset by the action of pressing the 4700 Reset key, or if the 4700 'Watchdog Bark' (malfunction) occurs. The reset command forces 4600 Power On state, with its switch mode power supply and its output Off. To minimize any incipient damage, these transitions are forced without sequencing.

Calibration

The entire AUTOCAL operation is controlled from the 4700, all the calibration constants being stored within the 4700 non-volatile calibration memory. Subsequently, these constants do not affect the gain of the 4600 internal circuitry, but modify the value of the reference voltage being fed from the 4700 via the analog cable to the 4600. The 4600 should therefore be slaved only to the individual 4700 which holds its calibration constants, otherwise invalid corrections will be applied.

Self Test

Pressing the Test key on the 4700 automatically checks both the 4700 and the 4600. This is additional to the 4600's normal testing, which includes continuous monitoring for catastrophic failures (such as power supplies), overload (overcompliance), input overdrive and overtemperature. These conditions are reported on the 4700 display as well as by the indicator LEDs on the 4600 front panel. Output turns Off when appropriate.

The relevant 4700 Test mode checks for the 4600 are described later in this section.

First ensure that the Reference Voltage Source and 4600 have been powered ON and warmed up for at least 1 hour, then use the following sequence to set up the solo operation, from ① to ⑪:

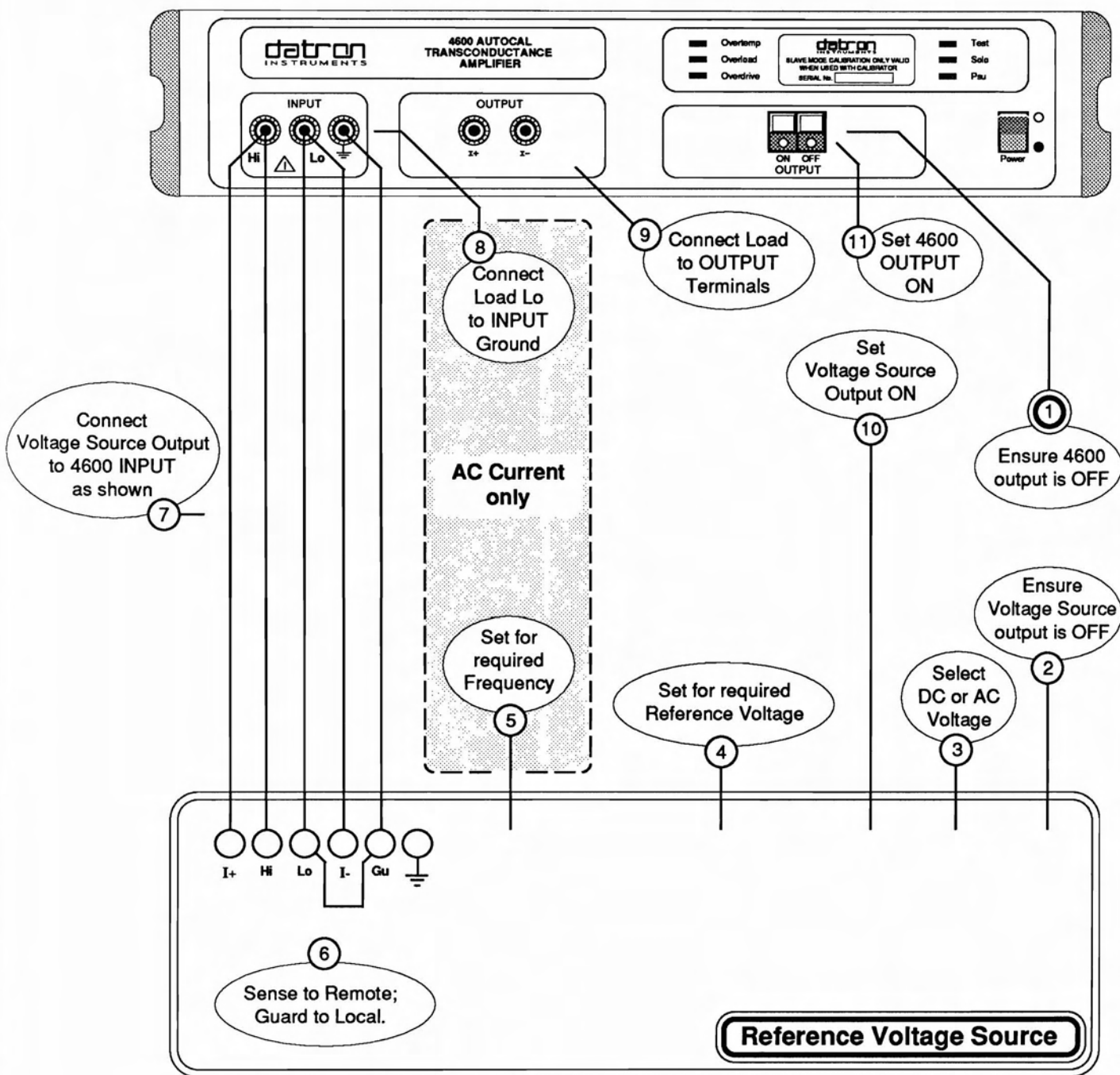

* To set Output Off, press the 4600 OUTPUT OFF key.

Fig. 3.3 GENERAL SEQUENCE OF OPERATIONS - SOLO MODE

Solo Mode - Operating Routines

Interconnections

The 4600 should be linked to its Reference Voltage source as shown in Fig. 3.3. The current output lead kit (Part Number 440154) can be used for connection from the 4600 to the Current output load.

Analog Operation

The reference voltage is fed into Hi and Lo INPUT terminals on the front of the 4600, to be converted into a current which passes out of the 4600 front panel I+ and I- OUTPUT terminals. The transfer characteristic is 1 amp per volt.

Local Control

The value and polarity of the 4600 output is controlled by the value and polarity of its input voltage, its output being switched On and Off by its own front-panel keys.

Calibration Corrections

Solo Mode corrections are incorporated at calibration by simple mechanical adjustments of trimpots. The trimpots are connected instead of using Autocal corrections when the 4600 is using a voltage source only as Reference, and is not slaved to a compatible 4700-series calibrator. These corrections are bypassed in Slave mode.

Solo Mode calibration procedures are given in Section 5.

Power Switches

Ensure that both 4600 and Reference Voltage Source Power switches are set to ON, and both instruments have warmed up for at least 1 hour.

DC Current Output

Use the General Sequence in Fig. 3.4. Modify selections as follows:

- At operation [3] select DC,
- Omit operations [5] and [8],
- Use operations [10], [11] and [4] as required.

N.B. For full specification, output compliance should be limited to 2V DC.

AC Current Output

Use the General Sequence in Fig. 3.4. Modify selections as follows:

- At operation [3] select AC,
- Use operations [10], [11], [4] and [5] as required.

N.B. For full specification, output compliance should be limited to 2V RMS.

Current Output On/Off

Once operating in Solo mode, the 4600 Current output is turned on and off from the 4600 front panel. All On/Off actions are sequenced by the 4600 to maintain a safe internal environment, and are thus subject to small delays.

Self Test

Error conditions such as power supply failure, overload (overcompliance), overtemperature and input overdrive are reported by the indicator LEDs on the 4600 front panel. All error conditions cause the Output to turn Off.

Systems Application via the IEEE 488 Interface

No direct connection to the IEEE 488 bus is required for the 4600. In Solo Mode its Output Current can be varied and set to zero, using the bus to program the Reference Voltage Source's output voltage, otherwise it is not programmable. In Slave mode it can be programmed via the 4700 interface as described below.

It is controlled remotely by using command **F2** or **F3** to program the 4700 into DCI or ACI function respectively, then using bus command **R6** to call up the 10A range. The Output Current value within the 10A range is set using the **M****** code as described in the 4700 series User's Handbook. Where frequent changes of range are programmed, it is possible to interlink the Current

output terminals of the two instruments in parallel, as the firmware isolates one output when the other is selected. Thus a single output analog bus can be set up, to which the outputs of the integrated system appear to derive from a single instrument. Switching the Current output Off isolates the 4700/4600 combination from the common analog bus.

When in function **F3**, range **R6**, the 4700/4600 combination can be programmed up to 20kHz using the **H****** codes. Otherwise, the 4600 responds to 4700 programming codes as if it were merely a sixth Current range of the 4700. Refer to the 4700 User's Handbook, Section 5.

SECTION 4 4600 Specifications and Verification

Specifications

Accuracy

Function and Range	Frequency (Hz)	Accuracy ±(ppm OUTPUT + ppm FS) [1] [2] [3]			Calibration Uncertainty (ppm)	Temperature Coefficient ±(ppm OUTPUT/°C) 3°C - 13°C 33°C - 43°C [4]	Total Harmonic Distortion %	Impedance	Compliance
		24 Hour 23°C±1°C	90 Day 23°C±1°C	1 Year 23°C±10°C					
DCI 0 - 11.00000A	-	30 +25	50 +25	150 +25	30	14	-	>100kΩ	>2V DC
ACI 0.9 - 11.00000A	10 - 1k	150 +55	200 +55	300 +60	110	20	0.1	>2kΩ	>2V RMS
	1k - 5k	650 +70	700 +70	800 +80	110	20	0.5	>2kΩ	>2V RMS
	5k - 10k	1050 +300	1400 +300	2100 +300	130	50	1.0	>400Ω	>2V RMS
	10k - 20k	4000 +1660	5400 +1660	7300 +1660	250 [5]	100	1.5	>67Ω	>2V RMS

General

Power Supply:	100/120/220/240 Volts ± 10%, 50Hz or 60Hz.
Power Consumption:	200 Watts.
Operating Temperature:	0°C to +50°C.
Storage Temperature:	-40°C to +70°C.
Dimensions:	89mm x 455mm x 420mm. 3.5" x 18" x 16.5"
Weight:	10kg.
Safety:	designed to UL1244, IEC348 & BS4743.
Warranty:	1 Year.

Other Specifications

Input Impedance:	300kΩ // 100pF.
Isolation:	100Vpk I- to Chassis.
Output Protection:	Fully protected against open and short circuits.
Input Protection:	240V RMS continuous.
DCI Output:	True bipolar output capable of delivering ±11A.
Overrange:	10%.
Settling Time:	1s to 40ppm of step size.
ACI Scale Length:	9% to 110% of range.
Settling Time:	To 100ppm of step size: 10Hz - 32Hz < 10s 32Hz - 330Hz < 3s 330Hz - 20kHz < 1s
Slave Mode Compatibility:	Datron 4708 Version 5.00 or later Datron 4700 Version 5.00 or later Datron 4705 Version 5.00 or later

Notes:

- [1] Relative to input voltage.
- [2] For resistive loads. Typical for inductive loads.
- [3] FS = 2 x Full Range.
- [4] Halve these coefficients for the range 23°C ± 10°C
- [5] Estimated.



4600 Specification Verification

Introduction

References

The factory calibration of the 4600 ensures traceable accuracy to national standards. Figures of performance are quoted in the specifications on page 4-1, related to time since calibration.

The following material deals with user-verification of the 4600 performance to specification, describing a recommended method of verifying each of the various parameters.

The following supplementary information is given in Appendices to the section:

- Appendix 1: Validity Tolerance Calculations.
- Appendix 2: Uncertainty and Traceability.
- Appendix 3: General Procedural Information.
- Appendix 4: Alternative AC Current Verification.
- Appendix 5: Harmonic Distortion Measurement.

Verification Sequence Profiles

The methods and sequence of verification depend on how the 4600 is intended to be used, and whether it was acquired in combination with a 4700-series calibrator. This leads to three broad ways of setting about the verification.

1. Solo Only

If the 4600 is not to be slaved to any 4700-series calibrator, then it will not be possible to verify its slaved operation. In this case, verify the specifications as follows:

- a. The Voltage Source to be used as reference for the 4600;
- b. The 4600 in Solo mode.

2. Acquired in Combination with a 4700-series Calibrator

In this case the combination will have been calibrated by the manufacturer. Verify the specifications in the following sequence:

- a. The calibrator
(detailed in Section 7 of its User's Handbook);
- b. The 4600 in Solo mode;
- c. The combination in Slave mode.

3. Slaved to an Existing 4700-series Calibrator

(Issue 5 firmware or later, fitted with Option 20 or 27, and with the analog and digital slaving connectors)

In the case of a 4600 which has been acquired to be slaved to such an existing 4700-series calibrator, the verification should be carried out using the following sequence:

- a. Ensure that the specification of the existing 4700-series calibrator is verified;
- b. Use that calibrator to verify the 4600 in Solo mode;
- c. Slave the 4600 to that same calibrator, and use the calibrator front panel keys to calibrate the slaved combination (refer to Section 5).
- d. Verify the slaved combination.

Verification Methods

Solo and Slave modes employ different independent methods of applying calibration corrections, with implications to the methods and criteria of verification for each mode:

- **In Solo mode** the corrections are applied, during calibration, by adjusting internal trim pots. The 4600 essentially converts a voltage to a current, so calibration (and hence verification) directly relates the current output to the voltage input, within specification limits. Thus the specification can be verified against any voltage source of suitable value and accuracy.
- **In Slave mode** the Solo mode trim pots are disconnected, (the two calibrations being totally independent of each other). No internal adjustments are provided, but the 4600 is autocalibrated as if it were just another Current range of its slaving 4700. Thus its calibration corrections are stored in the non-volatile memory of the 4700-series calibrator with which it was calibrated.

Therefore, if the 4600 is to be verified with a different 4700-series calibrator, it will need to be re-calibrated first. If the 4700-series calibrator and the 4600 are purchased as a combination, the calibration performed at the factory will be on the combination of the two units, therefore verification may proceed without recalibration.

In addition, the 4600 supplies both DC and AC outputs, so it is necessary to employ different verification methods for each.

User's Uncertainty Calculations

The range, accuracy and traceability of users' standards affects the manner in which the performance of any new equipment can be verified.

Users will need to evaluate the effects of their own Standards' uncertainties, so calculations for total tolerance limits (Validity Tolerance) are given in Appendix 1 to this section.

On receipt from the manufacturer, the Validity Tolerance must include the factory calibration uncertainties, but after user-calibration, these uncertainties no longer apply. The implications of this change, and other related matters, are discussed in Appendix 2 to this section.

4600 Solo Verification

General Philosophy

Measurement of Transconductance

To verify a 4600 in Solo mode, we check its transconductance value, by providing a traceable DC or AC voltage input and measuring the current output. Verifying 10 amperes of DC or AC current is not a simple matter, as most DMMs which have a 10A range cannot match the 4600's accuracy; indeed the 4600 is designed to calibrate such instruments.

DC Outputs

For DC output the verification method relies on the accuracy provided by the measurement of voltage across a precision 10A shunt, using a high-quality (ie stable) DMM, used only as a transfer-measurement device to remove its inherent uncertainties. A DC voltage, from the same traceable voltage source used as input to the 4600, is adjusted to achieve the same DMM reading as that measured across the shunt. The output voltage setting of the source is then compared against calculated limits.

The verification points used are: 0V, +10V and -10V of input voltage, producing 0A, +10A and -10A respectively. The source of DC voltage is referred to in the procedure as the 'DCRVs' (DC Reference Voltage Source).

AC Outputs

To verify the AC output, an AC/DC thermal transfer can be used with a 10A shunt. The AC reference voltage source is set to nominal 10V AC, and the Shunted TTS is nulled to the 4600 AC current output. The DCRVS is used as DC reference for the same 4600, and its output reference voltage is adjusted for the same current null as for AC (its DC specification being sufficiently accurate). The output voltage setting of the DC source is then compared against calculated limits.

The AC checks should be carried out immediately after the DC verification of the 4600, to take advantage of DC readings already taken.

The verification points used are: 10V RMS of input voltage at 300Hz, 5kHz and 20kHz in turn, producing 10A RMS at the same frequencies. To generate the reference DC current, the DCRVS is used as input to the 4600. The source of AC voltage is referred to in the procedure as 'ACRVs' (AC Reference Voltage Source).

Shunt Values

In the following procedures, the shunt voltage values are given for a 100m Ω shunt; values for a 10m Ω shunt are indicated by square braces [...].

Sequence Profile

Before embarking on any verification, decide which sequence profile is to be followed, after reading the paragraphs headed 'Verification Sequence Profiles' on page 4-3. The following procedures should form only part of that profile.

Warm-up Period

It is recommended that the 4600, DCRVS, ACRVS, DMM and Thermal Transfer Standard are powered on to warm up for at least 2 hours in the recommended environment, before carrying out any steps of the verification process.

Interconnections

Interconnection instructions in this section are necessarily simple and basic, and are mainly intended to show connections to the 4600. It is recognized that they may need to be adapted to meet an individual user's requirements.

Operation of Standards Equipment

It is assumed that users will possess adequate knowledge of the operation and use of the required standards equipment.

Validity Tolerance Calculations

The verification processes are modelled in Appendix 1 to this section. The validity tolerance limits are derived by calculations which are also given in Appendix 1.

Report Sheets

A report sheet is provided for each of the four recommended verification processes.

They are on pages 4600 RS 1-1 to 1-5 ahead of the Appendices, and should be used as masters for copying at each occasion when the 4600 is to be verified.

Alternative AC Current Verification

An alternative method of verifying AC current output, using a DMM for AC-AC transfer, can be found in Appendix 4 to this section. The Validity Tolerance Calculations, and Report Sheets RS 2 for this method, are contained within Appendix 4.

Solo DC Current Verification

Zero and Full Range Checks

The Solo 4600 is verified by measuring its transconductance. We use the DCRVS to input a nominal voltage, and measure the 4600 output current. A shunt converts the output current to a voltage, measured across the shunt using a DMM. The DCRVS output is then connected directly to the DMM and adjusted to give the same

reading as for the shunt voltage. The output setting of the DCRVS is compared against calculated limits.

This 'DC - DC Transfer' ensures that the DMM uncertainties are reduced to negligible levels.

Equipment Requirements

- A DC Reference Voltage Source (DCRVS), calibrated to suitable accuracy at Zero, $\pm 10\text{V}$ and $\pm 1\text{V}$ [$\pm 100\text{mV}$].
Example: A Datron 4000/A, 4700 or 4708.
- A Calibrated 10A Current Shunt of suitable accuracy, of value $100\text{m}\Omega$ [$10\text{m}\Omega$].
- A DMM of sufficient resolution and stability, for use as a transfer device to measure the DC voltage across the shunt.
Example: A Datron 1281, 1081 or 1071.

CAUTION

When choosing a 10A current shunt, ensure that its rated power dissipation is sufficient to avoid permanent degradation from the self-heating effects of the current being checked.

Summary of DC Procedure

General

The 4600 is verified at three output currents: 0A, +10A and -10A, corresponding to input voltages of 0V, +10V and -10V. The outputs pass through a precision current shunt of value $100\text{m}\Omega$ [or $10\text{m}\Omega$]; the resulting voltages of 0V, +1V and -1V [0V, +100mV and -100mV] are measured by a DC - DC transfer method, using a DMM.

4600 DC Output Current Measurement

The specification of the DC Reference Voltage Source (DCRVS) should be known to verify at the voltages to be used. Its output is applied to the Solo 4600 INPUT terminals. The OUTPUT I+ and I- terminals of the 4600 are connected to pass the output current through the shunt, and the DMM is connected to measure the voltage across the shunt. The DCRVS output voltage is set to the three nominal verification points in turn, and the DMM readings are noted.

DC - DC Transfer

The DCRVS output is then connected directly to the DMM input terminals, with the shunt connection removed. Its output voltage setting is adjusted in turn to give the same DMM voltage readings obtained across the shunt. For each of these readings the DCRVS output setting is noted. The accumulated uncertainties are also recorded, and the Validity Tolerance Limits are calculated. The 4600 verifies if the DCRVS output readings are within these tolerance limits.

Preparation

Before attempting any verification ensure that the following steps have been carried out.

1. Before connecting and operating any equipment, consult the manufacturers' handbooks.
2. Ensure that the DCRVS and DMM specifications verify at the following voltages:
DCRVS -10V; -1V [-100mV]; 0V; +1V [100mV]; +10V.
DMM -1V [-100mV]; 0V; +1V [+100mV].
3. Turn on the DCRVS, DMM and 4600 to be checked and allow at least 2 hours' warm-up in the specified environment.
4. Ensure that the DCRVS and 4600 Outputs are OFF.
5. The 4600 front panel LEDs should show no errors present. Carry out any self-test routine on the DCRVS.

The procedure is detailed on pages 4-6/7.

Solo DC Current Verification Procedure

Record results on Report Sheet 4600 RS 1, (Page RS1-2)

DC Output Current Measurement

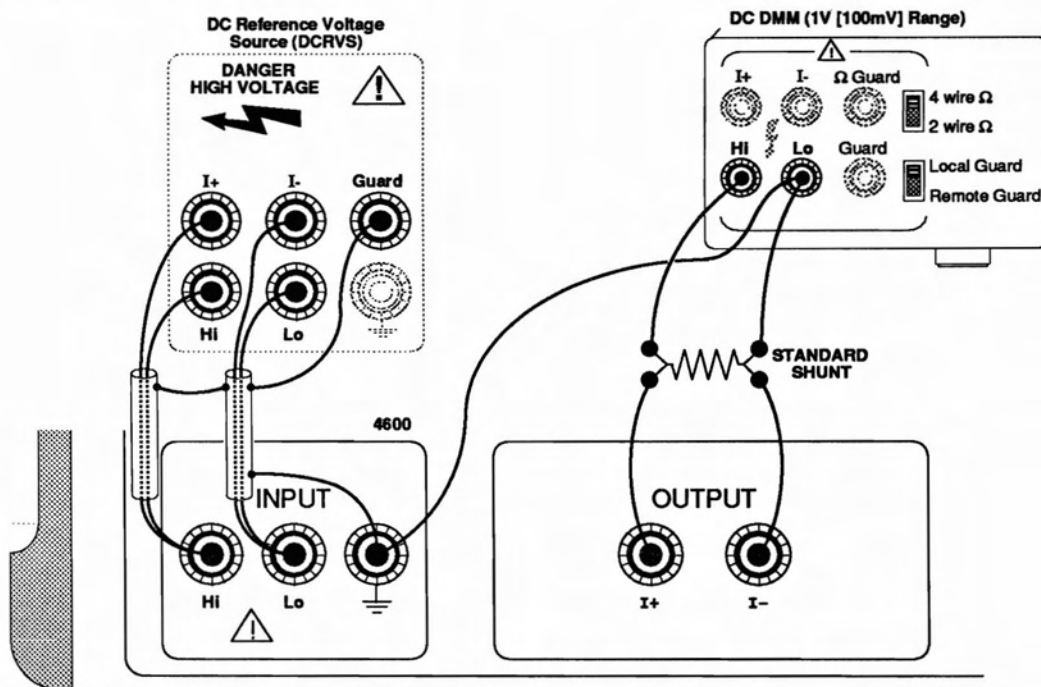

Connect the DCRVS, 4600, Shunt and DMM as shown in the above diagram (ensure the connection of DMM Lo to the 4600 INPUT ground).

Carry out operations (a) to (h) in turn:

- a. **DMM** Set DC range to measure the shunt voltage.
- b. **DCRVS** Ensure that OUTPUT is OFF, FUNCTION to DC Voltage, OUTPUT RANGE to 10V, Sense and Guard to Remote. OUTPUT voltage 0.00000V. Set Output ON.
- c. **4600** Set Output ON.
- d. **DMM** Record the reading in the Report Sheet RS1, as DMM Transfer Reading: 'V0'.
- e. **DCRVS** Set Output to +10.00000V.
- f. **DMM** Record the reading in the Report Sheet RS1, as DMM Transfer Reading: '+V1'.
- g. **DCRVS** Set Output to -10.00000V.
- h. **DMM** Record the reading in the Report Sheet RS1, as DMM Transfer Reading: '-V1'.
- j. **4600** Set Output OFF.
- k. **DCRVS** Set Output OFF.

DC - DC Transfer

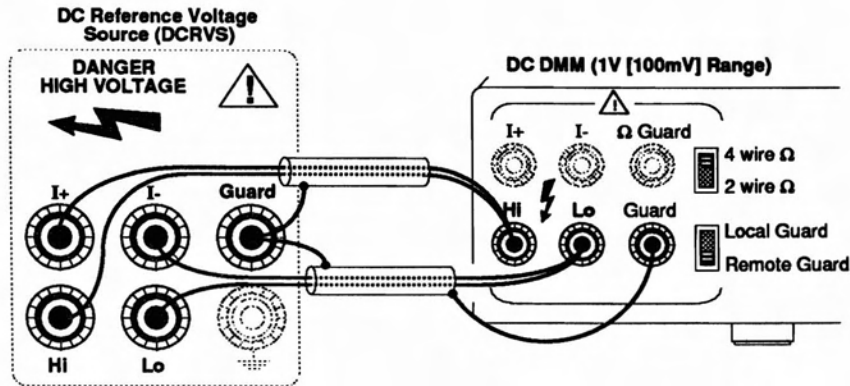

Connect the DMM to read the DCRVS output as in the above diagram. Ensure that the DMM Guard is set to remote.

Carry out operations (j) to (r) in turn:

- j. DCRVS** Ensure that OUTPUT is OFF, FUNCTION to DC Voltage, OUTPUT RANGE to 1V [100mV], Sense to Remote. Guard to Local.
- k. DMM** Set DC range to measure 'V0'.
- l. DCRVS** Set OUTPUT ON. Adjust the DCRVS output voltage to give a DMM reading of 'V0'. Record the DCRVS output voltage setting against 'V_m' in the 0A column of RS1 Table 1. Set OUTPUT OFF.
- m. DMM** Set DC range to measure '+V1'.
- n. DCRVS** Set OUTPUT ON. Adjust the DCRVS output voltage to give a DMM reading of '+V1'. Record the DCRVS output voltage setting against 'V_m' in the +10A column of RS1 Table 1. Set OUTPUT OFF.
- p. DMM** Set DC range to measure '-V1'.
- q. DCRVS** Set OUTPUT ON. Adjust the DCRVS output voltage to give a DMM reading of '-V1'. Record the DCRVS output voltage setting against 'V_m' in the -10A column of RS1 Table 1. Set OUTPUT OFF.

Validity Tolerance Limit Calculations

Refer to Appendix 1 page 4-A1-1.

- r.** Calculate the Lower and Upper V_m Tolerance Limits.
- Use Calculation A if the 4600 was last calibrated by Datron.
 - Use Calculation B if the 4600 was last calibrated against the standards being used for verification.
 - Use Calculation C if the verification immediately follows a calibration using the same equipment.

The Solo Zero and ±Full Range DC outputs verify if the values of V_m recorded in (l), (n) and (q) are at or between the corresponding V_m Tolerance Limits.

Solo AC Current Verification

Full Range Checks

The Solo 4600 is verified by measuring its transconductance. A Thermal Transfer Standard (TTS), in conjunction with a 10A shunt, is first nulled at the nominal Full Range 10A AC current output from the 4600; using the ACRVS to provide the 4600 input reference voltage.

We then use the DCRVS to input DC voltage to the 4600, adjusting the input voltage value to obtain a null on the TTS. The DCRVS output voltage settings to obtain the null are compared against calculated limits.

Equipment Requirements

- The DC Reference Voltage Source (DCRVS) used in the previous procedure to verify the 4600 DC current output.
Example: A Datron 4000/A, 4700 or 4708.
- An AC Reference Voltage Source (ACRVS) of suitable accuracy, with its specification verified for 10V RMS outputs at 300Hz, 5kHz and 20kHz.
Example: A Datron 4200A, 4700 or 4708.
- A Calibrated AC 10A Thermal Transfer Current Shunt of suitable accuracy, of value 100m Ω [10m Ω].
Example: Holt HCS 1.
- A Thermal Transfer Standard of sufficient resolution and stability, for use in conjunction with the shunt.

CAUTION

When choosing a 10A current shunt, ensure that its rated power dissipation is sufficient to avoid permanent degradation from the self-heating effects of the current being checked.

Summary of AC Procedure

General

The 4600 is verified for three output currents: 10A RMS at 300Hz, 5kHz and 20kHz; for input voltages of 10V RMS at those frequencies. The AC outputs are measured using a thermal transfer standard with a precision current shunt of value 100m Ω [or 10m Ω]; the 4600 DC output is used as reference current.

TTS Null to 4600 AC Output Current

The OUTPUT I+ and I- terminals of the 4600 are connected to pass the output current to a thermal transfer standard, used in conjunction with a 10A current shunt. The TTS is nulled for AC output currents at 300Hz, 5kHz and 20kHz, derived by driving the 4600 from the ACRVS set to nominal 10V AC output at each of the three frequencies.

AC - DC Thermal Transfer

The DCRVS output is then applied to the 4600 input. This voltage is adjusted for the 4600 output current to give a null on the TTS. The DCRVS output setting is recorded. The accumulated uncertainties are also recorded, and the Validity Tolerance Limits calculated. The 4600 is verified if the DCRVS output reading is within these tolerance limits.

Preparation

Before attempting any verification ensure that the following steps have been carried out:

1. Before connecting and operating any equipment, consult the manufacturers' handbooks.
2. Check that the DCRVS specification is verified at 10V DC output, and that the ACRVS specification is verified for 10V output at 300Hz, 5kHz and 20kHz.
3. Check that the Solo 4600 specification is verified for +10A DC output.
4. Check that the DCRVS, ACRVS, TTS and 4600 are fully warmed up, and their Outputs are OFF.
5. The 4600 front panel LEDs should show no errors present.

The procedure is detailed on pages 4-10/11.

Solo AC Current Verification Procedure

Record results on Report Sheet 4600 RS 1, (Page RS1-3)

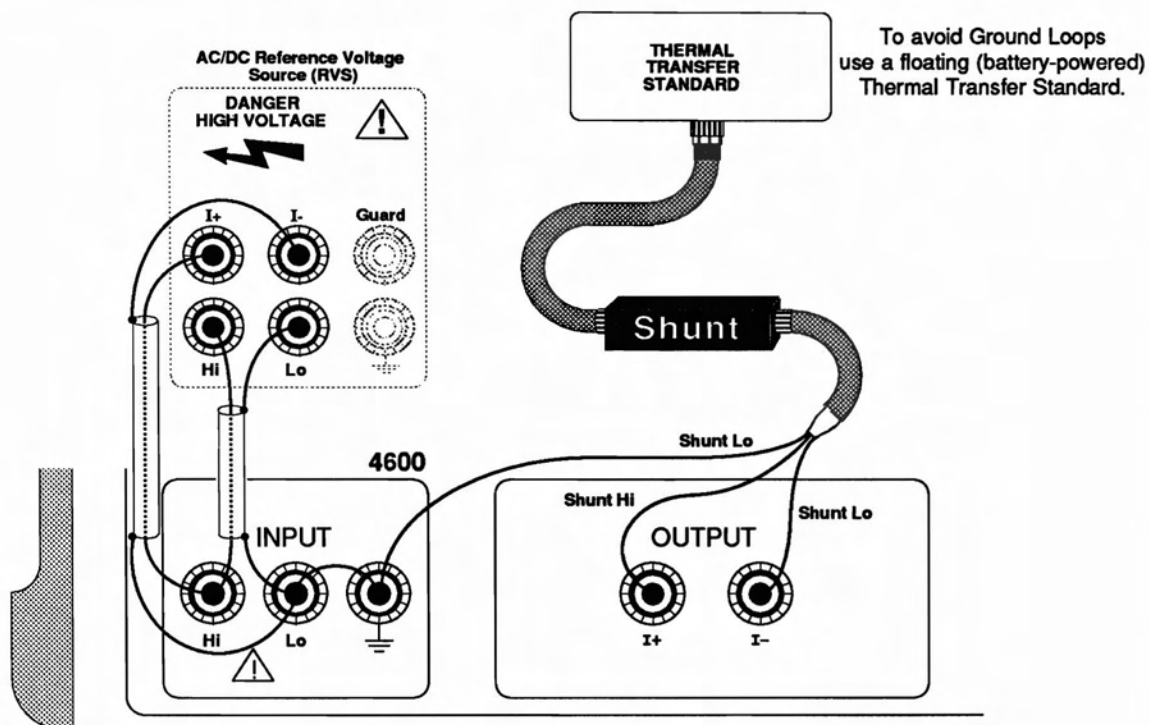

Measure at 300Hz

Null the TTS to the 4600 AC Output Current

Connect the ACRVS output to the 4600 INPUT terminals as in the diagram. Connect the shunt and TTS to the 4600 OUTPUT terminals as shown (ensure the connection of Shunt Lo to the 4600 INPUT ground).

Carry out operations (a) to (g):

- a. **ACRVS** Ensure that OUTPUT is OFF, FUNCTION to AC Voltage, FREQUENCY to 300Hz, OUTPUT RANGE to 10V, Sense to Remote; Guard to Local. OUTPUT voltage to 10.00000V RMS.
- b. **TTS** Set range to maximum.
- c. **ACRVS** Set OUTPUT ON.
- d. **4600** Set OUTPUT ON. Note that the TTS indicates.
- e. **TTS** Adjust for a Null reading. Reduce range for the largest stable reading. Allow the reading to stabilize. Readjust for a Null reading.
- f. **4600** Set OUTPUT OFF.
- g. **ACRVS** Set OUTPUT OFF.

AC - DC Thermal Transfer

Disconnect the ACRVS output from the 4600 INPUT terminals and connect the DCRVS in its place.

Carry out operations (h) to (k):

- h. **DCRVS** Ensure that OUTPUT is OFF, FUNCTION to DC Voltage, OUTPUT RANGE to 10V, Sense and Guard to Remote. Set OUTPUT ON. Adjust OUTPUT voltage for a Null reading on the TTS, increasing TTS sensitivity to obtain the best null. Allow the reading to stabilize. Readjust OUTPUT voltage for a Null reading on the TTS. Record the Output voltage setting on RS1 Table 2 against V_m in the 300Hz column. Set OUTPUT OFF.
- j. **4600** Set OUTPUT OFF.
- k. Disconnect the DCRVS from the 4600 INPUT terminals.

Measure at 5kHz

- l. Repeat as for the 300Hz procedure, but setting the ACRVS frequency to **5kHz** at operation (a). At operation (h) record the output voltage setting against **V_m** in the **5kHz** column.

Measure at 20kHz

- m. Repeat as for the 300Hz procedure, but setting the ACRVS frequency to **20kHz** at operation (a). At operation (h) record the output voltage setting against **V_m** in the **20kHz** column.

Verify Against Calculated Limits

Validity Tolerance Limit Calculations

Refer to Appendix 1 page 4-A1-3.

- n. Calculate the Lower and Upper **V_m** Tolerance Limits.
 - Use Calculation A if the 4600 was last calibrated by Datron.
 - Use Calculation B if the 4600 was last calibrated against the standards being used for verification.
 - Use Calculation C if the verification immediately follows a calibration using the same equipment.

The Solo Full Range AC outputs verify if the values of **V_m** recorded in operations (h), (l) and (m) are at or between the corresponding **V_m** Tolerance Limits.

4600 Slave Verification

N.B. In this sub-section, reference to a '4700' refers also to a compatible model 4705, 4707 or 4708.

General Philosophy

Measurement of Output

To verify a combined 4600 in Slave mode, we should first have measured its transconductance value in Solo mode, to check the independent, manual Solo calibration. This is because in Slave mode, the actual reference voltage input to the 4600 is inaccessible due to the front panel INPUT terminals being isolated, and so the transconductance cannot be checked when slaved.

To verify a 4600 which is slaved to a particular 4700-series calibrator, we measure its output current (using the same techniques as for Solo mode), which is then compared against the slaving 4700's OUTPUT setting.

DC Outputs

For DC output the verification method relies on the accuracy provided by the measurement of voltage across a precision 10A shunt, using a high-quality (ie stable) DMM, used only as a transfer-measurement device to remove its inherent uncertainties. A DC voltage, from the slaving 4700, is adjusted to achieve the same DMM reading as that measured across the shunt. The output display setting of the 4700 is then compared against calculated limits. The combination is verified at: 0A, +10A and -10A.

AC Outputs

To verify the AC output, an AC/DC thermal transfer can be used with a 10A shunt. The slaving 4700 is set to nominal 10A AC, and the Shunted TTS is nulled to the 4600 AC current output. The 4700 setting is changed to the 10A DC range, and the 4600 DC output is adjusted for the same current null as for AC. The 4700 DC current OUTPUT setting is then compared against calculated limits.

The AC checks should be carried out immediately after the DC verification of the 4600, to take advantage of DC readings already taken.

The verification points used are: 10A RMS of output current at 300Hz, 5kHz and 20kHz in turn.

Shunt Values

In the following procedures, the shunt voltage values are given for a 100m Ω shunt; values for a 10m Ω shunt are indicated by square braces [...].

Sequence Profile

Before embarking on any verification, decide which sequence profile is to be followed, after reading the paragraphs headed 'Verification Sequence Profiles' on page 4-2. The following procedures should form only part of that profile.

Prior Calibration of the Combination

The 4600 cannot be verified with any 4700-series calibrator, other than that with which it was calibrated in Slave mode. That particular 4700 holds the corrections which were stored at the prior calibration, in its non-volatile calibration memory.

If the 4700 and 4600 to be verified were purchased as a combination, Slave mode would have been calibrated before shipment and verification can proceed without further calibration. But if the 4600 has not yet been calibrated in Slave mode with the 4700 to be used for verification, it is necessary to perform this calibration (detailed in Section 5) before verifying as described in this sub-section.

Warm-up Period

It is recommended that the 4600, 4700, DMM and Thermal Transfer Standard are powered on to warm up for at least 2 hours in the recommended environment, before carrying out any steps of the verification process.

Interconnections

Interconnection instructions in this section are necessarily simple and basic, and are mainly intended to show connections to the 4600. It is recognized that they may need to be adapted to meet an individual user's requirements.

Operation of Standards Equipment

It is assumed that users will possess adequate knowledge of the operation and use of the required standards equipment.

Validity Tolerance Calculations

The verification processes are modelled in Appendix 1 to this section. The validity tolerance limits are derived by calculations which are also given in Appendix 1.

Report Sheets

A report sheet is provided for each of the four recommended verification processes.

They are on pages 4600 RS 1-1 to 1-5 ahead of the Appendices, and should be used as masters for copying at each occasion when the 4600 is to be verified.

Alternative AC Current Verification

An alternative method of verifying AC current output, using a DMM for AC-AC transfer, can be found in Appendix 4 to this section. The Validity Tolerance Calculations, and Report Sheets RS 2 for this method, are contained within Appendix 4.

Slave DC Current Verification

Zero and Full Range Checks

The slaved 4600 is verified by measuring its output. We compare the output current value against the 4700 OUTPUT setting. A shunt converts the output current to a voltage, measured across the shunt using a DMM. The 4700 voltage output is then connected directly to the DMM and adjusted to give the same reading as for

the shunt voltage. The 4700 OUTPUT display setting is compared against calculated limits.

This 'DC - DC Transfer' ensures that the DMM uncertainties are reduced to negligible levels.

Equipment Requirements

- The slaving 4700, DC voltage verified to suitable accuracy at Zero, $\pm 10\text{V}$ and $\pm 1\text{V}$ [$\pm 100\text{mV}$], and previously calibrated in Slave mode with the 4600 to be verified.
- A Calibrated 10A Current Shunt of suitable accuracy, of value $100\text{m}\Omega$ [$10\text{m}\Omega$].
- A DMM of sufficient resolution and stability, for use as a transfer device to measure the DC voltage across the shunt.
Example: A Datron 1281, 1081 or 1071.

CAUTION

When choosing a 10A current shunt, ensure that its rated power dissipation is sufficient to avoid permanent degradation from the self-heating effects of the current being checked.

Summary of DC Procedure

General

The 4600 is verified at three output currents: 0A, +10A and -10A. The outputs are passed through a precision current shunt of value $100\text{m}\Omega$ [or $10\text{m}\Omega$], the resulting voltages of 0V, +1V and -1V [0V, +100mV and -100mV] being measured by a DC - DC transfer method, using a DMM.

4600 DC Output Current Measurement

The specification of the 4700 should be known to verify at the voltages to be used. It is connected in slave mode to the 4600. The OUTPUT I+ and I- terminals of the 4600 are connected to pass the output current through the shunt, and the DMM is connected to measure the voltage across the shunt. The 10A range OUTPUT display is set to the three nominal verification points in turn, and the DMM readings are noted.

DC - DC Transfer

The 4700 output is then connected directly to the DMM input terminals, with the shunt connection removed. Its output voltage setting is adjusted in turn to give the same DMM voltage readings obtained across the shunt. For each of these readings the 4700 output setting is noted. The accumulated uncertainties are also recorded, and the Validity Tolerance Limits are calculated. The 4600 verifies if the 4700 OUTPUT display settings are within these tolerance limits.

Preparation

Before attempting any verification ensure that the following steps have been carried out.

1. Before connecting and operating any equipment, consult the manufacturers' handbooks.
2. Ensure that the 4700 and DMM specifications verify at the following voltages:

4700	-10V; -1V [-100mV]; 0V; +1V [100mV]; +10V.
DMM	-1V [-100mV]; 0V; +1V [+100mV].
3. Turn on the 4700, DMM and 4600 to be checked and allow at least 2 hours' warm-up in the specified environment.
4. Ensure that the 4700 and 4600 Outputs are OFF.
5. The 4600 front panel LEDs should show no errors present. Press the 4700 Test key to carry out the self-test routine on the 4700/4600 combination.

The procedure is detailed on pages 4-14/15.

Slave DC Current Verification Procedure

Record results on Report Sheet 4600 RS 1, (Page RS1-4)

DC Output Current Measurement

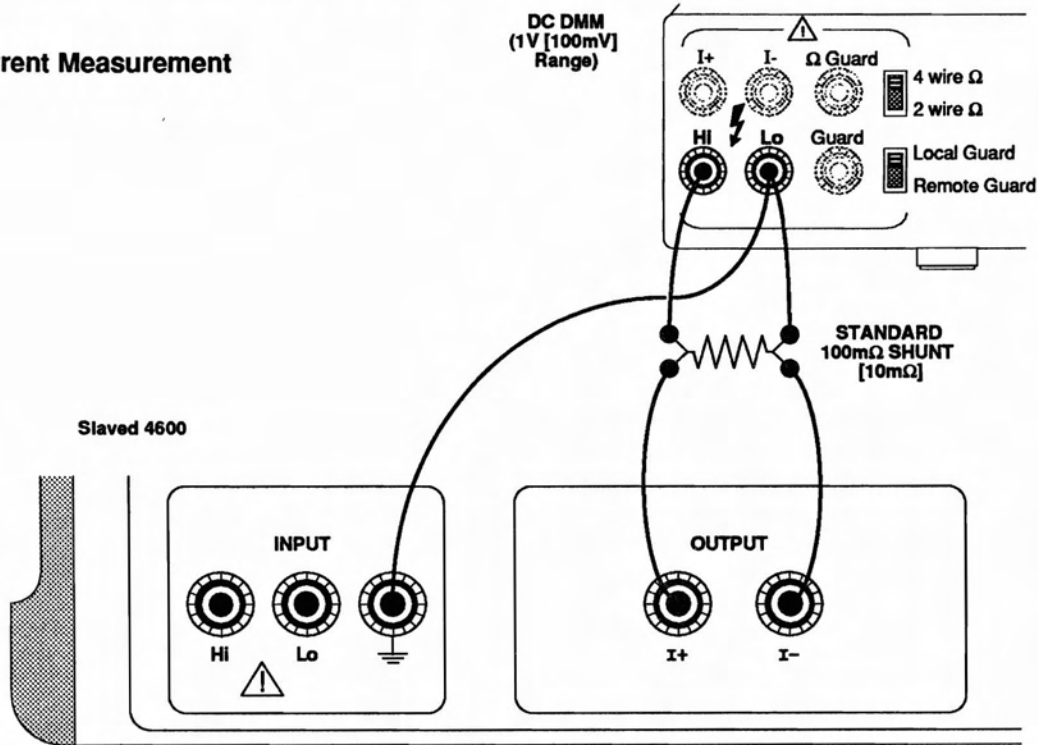

Connect the slaved 4600, Shunt and DMM as shown in the above diagram (ensure the connection of DMM Lo to the 4600 INPUT ground).

Carry out operations (a) to (k) in turn:

- a. **DMM** Set DC range to measure the shunt voltage.
- b. **4700** Ensure that OUTPUT is OFF, FUNCTION to DC, then I, RANGE to 10, Guard and Sense are controlled internally by firmware. OUTPUT to 0.00000A by pressing the 'Zero' key. Press the ON+ key. Check that the 4700 and 4600 ON key LEDs light and the DMM indicates. Press the OFF key. Check that the 4700 and 4600 ON key LEDs go out, OFF LEDs light and the DMM indication falls to zero.
- c. **4600** Press the OUTPUT ON key. Check that the 4700 and 4600 ON key LEDs light and the DMM indicates. Press the OUTPUT OFF key. Check that the 4700 and 4600 ON key LEDs go out, OFF LEDs light and the DMM indication falls to zero.
- d. **4700** Press the OUTPUT ON+ key.
- e. **DMM** Record the reading in the Report Sheet RS1, as DMM Transfer Reading: 'V0'.
- f. **4700** Press the Full Range key to set the OUTPUT display reading to +10.00000A.
- g. **DMM** Record the reading in the Report Sheet RS1, as DMM Transfer Reading: '+V1'.
- h. **4700** Press the ON- key to set the OUTPUT display reading to -10.00000A.
- j. **DMM** Record the reading in the Report Sheet RS1, as DMM Transfer Reading: '-V1'.
- k. **4700** Set Output OFF.

DC - DC Transfer

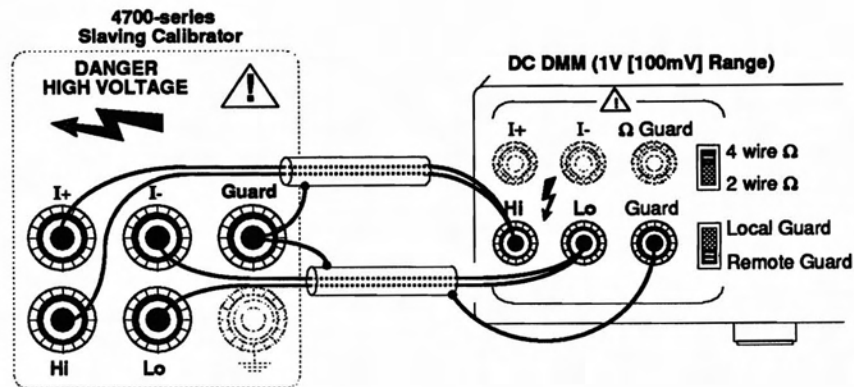

Connect the DMM to read the 4700 output as in the above diagram. Ensure that the DMM Guard is set to **Remote**.

Carry out operations (l) to (t) in turn:

- l. 4700 Ensure that OUTPUT is OFF, FUNCTION to DC, OUTPUT RANGE to 1 [100m], Sense to Remote. Guard to Local.
- m. DMM Set DC range to measure 'V0'.
- n. 4700 Set OUTPUT ON+. Using the OUTPUT $\uparrow \downarrow$ keys, adjust the 4700 output voltage to give a DMM reading of 'V0'. Record the 4700 OUTPUT display setting against 'V_m' in the 0A column of RS1 Table 3. Set OUTPUT OFF.
- p. DMM Set DC range to measure '+V1'.
- q. 4700 Set OUTPUT ON+. Using the OUTPUT $\uparrow \downarrow$ keys, adjust the 4700 output voltage to give a DMM reading of '+V1'. Record the 4700 OUTPUT display setting against 'V_m' in the +10A column of RS1 Table 3. Set OUTPUT OFF.
- r. DMM Set DC range to measure '-V1'.
- s. 4700 Set OUTPUT ON-. Using the OUTPUT $\uparrow \downarrow$ keys, adjust the 4700 output voltage to give a DMM reading of '-V1'. Record the 4700 OUTPUT display setting against 'V_m' in the -10A column of RS1 Table 3. Set OUTPUT OFF.

Validity Tolerance Limit Calculations

Refer to Appendix 1 page 4-A1-5.

- t. Calculate the Lower and Upper V_m Tolerance Limits.
 - Use Calculation A if the 4600 was last calibrated by Datron.
 - Use Calculation B if the 4600 was last calibrated against the standards being used for verification.
 - Use Calculation C if the verification immediately follows a calibration using the same equipment.

The Slave Zero and \pm Full Range DC outputs verify if the values of V_m recorded in (n), (q) and (s) are at or between the corresponding V_m Tolerance Limits.



Slave AC Current Verification

Full Range Checks

The Slave 4600 is verified by measuring its output. A Thermal Transfer Standard (TTS), in conjunction with a 10A shunt, is first nulled at the nominal 10A AC current output from the 4700/4600 combination.

We then switch the combination to output DC current, and adjust the 4700 OUTPUT display value to obtain a null on the TTS. The 4700 OUTPUT display settings to obtain the null are compared against calculated limits.

Equipment Requirements

- The slaving 4700, AC voltage verified to suitable accuracy at 10V for frequencies of 300Hz, 5kHz and 20kHz; previously calibrated in Slave mode with the 4600 to be verified. Verification of the 10A DC output of the same 4700/4600 combination must have been carried out within the previous 24 hours.
- A Calibrated AC 10A Thermal Transfer Current Shunt of suitable accuracy, of value 100mΩ [10mΩ].
Example: Holt HCS 1.
- A Thermal Transfer Standard of sufficient resolution and stability, for use in conjunction with the shunt.

CAUTION

When choosing a 10A current shunt, ensure that its rated power dissipation is sufficient to avoid permanent degradation from the self-heating effects of the current being checked.

Summary of AC Procedure

General

The 4600 is verified for three output currents: 10A RMS at 300Hz, 5kHz and 20kHz. The AC outputs are measured using a thermal transfer standard in conjunction with a precision current shunt of value 100mΩ [or 10mΩ], against the 4600 DC output used as reference current.

TTS Null to 4600 AC Output Current

The OUTPUT I+ and I- terminals of the slaved 4600 are connected to pass output current to a thermal transfer standard, used in conjunction with a 10A current shunt. The TTS is nulled for AC output currents at 300Hz, 5kHz and 20kHz, derived by setting the 4700 to nominal 10A AC output at each of the three frequencies.

AC - DC Thermal Transfer

The 4700 is then switched to its 10A DC range. Its output display is adjusted to give a null on the TTS, and the actual display setting is recorded. The accumulated uncertainties are also recorded, and the Validity Tolerance Limits calculated. The 4600 is verified if the 4700 output display setting is within these tolerance limits.

Preparation

Before attempting any verification ensure that the following steps have been carried out.

1. Before connecting and operating any equipment, consult the manufacturers' handbooks.
2. Check that the 4700 specification is verified for 10V AC output at 300Hz, 5kHz and 20kHz.
3. Check that the slaved 4700/4600 specification is verified for +10A DC output.
4. Check that the TTS, 4700 and 4600 are fully warmed up, and their Outputs are OFF.
5. The 4600 front panel LEDs should show no errors present.

The procedure is detailed on pages 4-18/19.

Slave AC Current Verification Procedure

Record results on Report Sheet 4600 RS 1, (Page RS1-5)

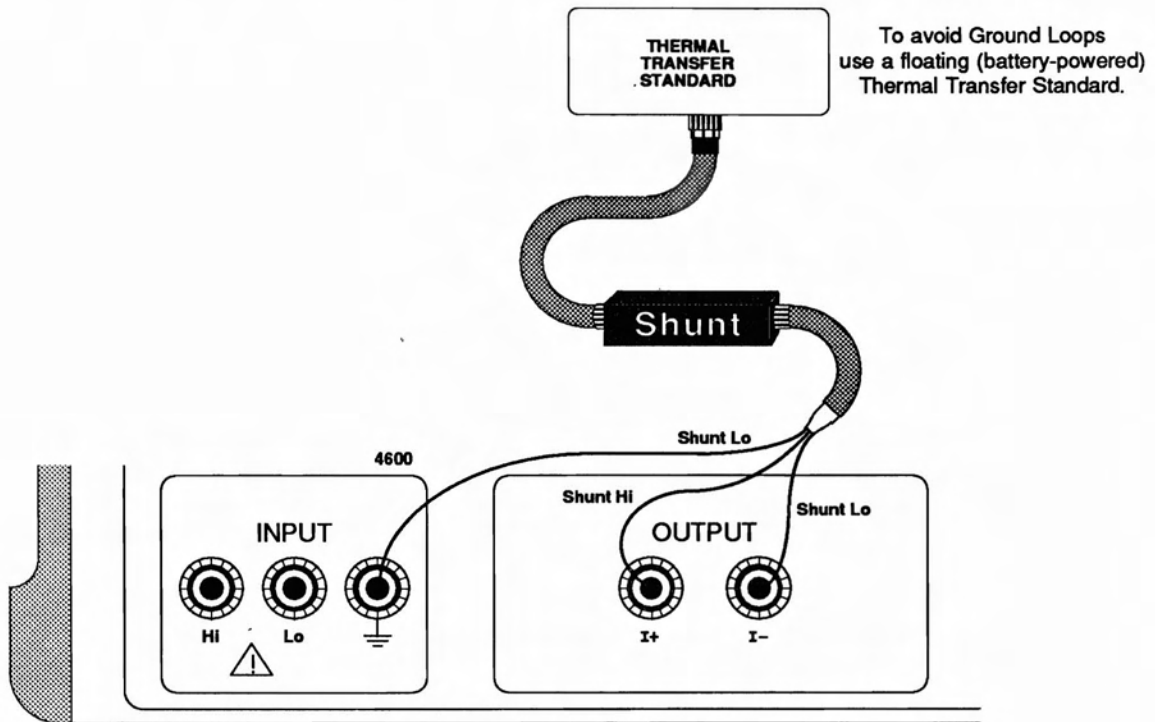

Measure at 300Hz

Null the TTS to the 4600 AC Output Current

Connect the shunt and TTS to the slaved 4600 OUTPUT terminals as shown in the diagram (ensure the connection of Shunt Lo to the 4600 INPUT ground).

Carry out operations (a) to (e):

- a. 4700 Ensure that OUTPUT is OFF, FUNCTION to AC then I, FREQUENCY to 300Hz, OUTPUT RANGE to 10, Guard and Sense are controlled internally by firmware. Press the Full Range key to set the 4600 output current to 10.00000A RMS.
- b. TTS Set range to maximum.
- c. 4700 Set OUTPUT ON.
- d. TTS Adjust for a Null reading. Reduce range for the largest stable reading. Allow the reading to stabilize. Readjust for a Null reading.
- e. 4700 Set OUTPUT OFF.

AC - DC Thermal Transfer

Carry out operation (f):

- f. 4700 Ensure that OUTPUT is OFF, FUNCTION to DC then I, OUTPUT RANGE to 10, Press OUTPUT ON+ key. Using OUTPUT \uparrow \downarrow keys, adjust the 4600 output current for a Null reading on the TTS, increasing TTS sensitivity to obtain the best null. Allow the reading to stabilize. Readjust output current for a Null reading on the TTS. Record the OUTPUT display current setting on RS1 Table 4 against DCIm in the 300Hz column. Set OUTPUT OFF.

Measure at 5kHz

- g. Repeat as for the 300Hz procedure, but setting the 4700 frequency to **5kHz** at operation (a). At operation (f) record the output voltage setting against DCIm in the **5kHz** column.

Measure at 20kHz

- h. Repeat as for the 300Hz procedure, but setting the 4700 frequency to **20kHz** at operation (a). At operation (f) record the output voltage setting against DCIm in the **20kHz** column.

Verify Against Calculated Limits

Validity Tolerance Limit Calculations

Refer to Appendix 1 page 4-A1-7.

- n. Calculate the Lower and Upper DCIm Tolerance Limits.
- Use Calculation A if the 4600 was last calibrated by Datron.
 - Use Calculation B if the 4600 was last calibrated against the standards being used for verification.
 - Use Calculation C if the verification immediately follows a calibration using the same equipment.

The Slave Full Range AC outputs verify if the values of DCIm recorded in operations (f), (g) and (h) are at or between the corresponding DCIm Tolerance Limits.

Verification Report

4600 RS 1

Model 4600

4600 Serial Number.....

Associated 4700/4705/4707/4708 Serial Number.....

Calibration Interval --- 90days---...

Specification --- Accuracy ---.....

Date.....

Checked by.....

Company/Dept.....

Note: On receipt of the instrument it is recommended to check at the values shown in the tables.

The 'Validity Tolerance'

Why is it necessary to calculate this tolerance?

It is impossible to verify the specification of an instrument with absolute certainty, even using the original calibration equipment to make measurements. All measurements carry a degree of uncertainty, this being quantified by the traceability of the measuring equipment.

The measurements attempt to verify that the instrument performs within its specification; ie. it operates within the tolerance of its accumulated uncertainties. But as the measurement itself has its own accumulated uncertainties, these must be added to those of the instrument in order to set a 'Validity Tolerance'.

If an instrument performs within its validity tolerances, all that can be assumed is that its verification is uncertain. For example; if results agree exactly with the instrument settings, the measurements are still

at least as uncertain as the traceability (to absolute accuracy) of the measuring equipment. The only certainty is that if one result exceeds its validity tolerance, then the instrument has failed to verify.

For a verification measurement to be acceptable, therefore, each validity tolerance must express a continuous trace of all the uncertainties from the instrument terminals, via 'Absolute Accuracy', to the measuring equipment connections to those terminals. The validity tolerance of the trace is obtained by adding together all the intervening uncertainties at the time the measurement is made. The specification sets out the worst-case allowances (relative tolerances) for the instrument performance. For the measuring equipment, worst-case tolerances must also be assumed. The full extent of the accumulation is illustrated below in the simplified diagram:

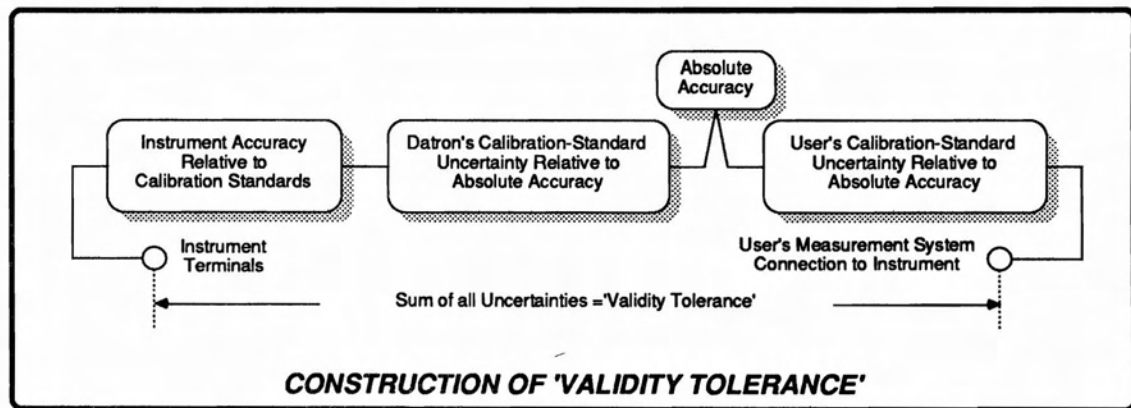

Implementation on Receipt of Instrument

The tables in this report document provide columns to enter both the relevant results of measurements and results of calculations from the measurements. Guidance is given in the form of calculation equations, where to obtain information, and tables to simplify the calculations.

Wherever appropriate and possible, the figures in the columns are already entered (90 day Specification). The recommended methods of setting up the equipment, and measuring the instrument outputs, are described in the body of Section 4.

Implementation after User-calibration

Once the instrument has been calibrated against the user's standards, then Datron's calibration-standard uncertainties can be removed from the validity tolerance calculation.

It is still necessary to include the worst-case user's calibration-standard uncertainties for the time period elapsed since the instrument was last verified or calibrated.

It is anticipated that users will wish to employ their own standard report formats on these occasions.

TABLE 1. SOLO DC CURRENT

Zero and Full Range Checks

Calculate Total Measurement Uncertainty (Enter all uncertainties in ppm)		4600 Output Measurement Uncertainties (\pm ppm of Full Range)								
		0A			+10A			-10A		
Shunt Accuracy relative to Absolute	Ur									
4600 Accuracy relative to Cal. Stds.	Ug	24hr 50	90dy 50	1yr 50	24hr 80	90dy 100	1yr 200	24hr 80	90dy 100	1yr 200
Datron Cal Std uncertainty relative to Absolute	Ud^[1]	30	30	30	30	30	30	30	30	30
User's Cal Std uncertainty relative to Absolute	Uc^[2]									
Total Measurement Uncertainty (Validity Tolerance)	DCUt									

Calculate Validity Tolerance Limits

Value of DC Current Shunt	Rs		Ω		Ω		Ω
Target Value for Vm	TgtVm^[3]		v		v		v
Upper Tolerance Limit for Vm	ULVm		v		v		v
Lower Tolerance Limit for Vm	LLVm		v		v		v

DMM Readings and DCRVS Settings

DMM Transfer Readings		'V0' =	v	'+V1' =	v	'-V1' =	v
Actual DCRVS Settings (Vm) for DMM Transfer Reading	Vm		v		v		v

Notes:

1. Use Ud only if the 4600 was last calibrated by Datron.
2. Use Uc only if the 4600 was **not** last calibrated by Datron. Enter the calibration uncertainty for the most-recent calibration.
3. The value of TgtVm is dependent on the value Rs of the shunt.

TABLE 2. SOLO AC CURRENT

Full Range Checks

Calculate Total Measurement Uncertainty (ppm)		4600 Output Measurement Uncertainties (\pm ppm of Full Range) - Verification Frequencies -								
		300Hz			5kHz			20kHz		
Total DC Measurement Uncertainty (from DC Verification)	DCU ^{t(1)} + U _v									
ACRVS Accuracy (absolute)	ACU _v									
4600 AC Accuracy relative to Cal. Stds.	ACU _g	24hr 260	90dy 310	1yr 420	24hr 790	90dy 840	1yr 960	24hr 7320	90dy 8720	1yr 10620
Datron AC Cal. Standard Uncert. relative to Absolute	ACU _d ⁽²⁾	110	110	110	110	110	110	250*	250*	250*
User's AC Cal. Standard Uncert. relative to Absolute	ACU _c ⁽³⁾									
Total Measurement Uncertainty (Validity Tolerance)	ACU _t									

Calculate Validity Tolerance Limits

TTS Transfer Function	F _{tr}									
Target Value for V _m	TgtV _m ⁽⁴⁾			v			v			v
Upper Tolerance Limit for V _m	ULV _m			v			v			v
Lower Tolerance Limit for V _m	LLV _m			v			v			v
DCRVS setting (V _m) for Thermal Transfer Null	V _m			v			v			v

Notes:

- DCU_t was calculated during the previous DC verification. Ensure that the correct Cal. Std. Uncertainty (U_d or U_c) was included.
- Use ACU_d only if the 4600 was last calibrated by Datron.
- Use ACU_c only if the 4600 was **not** last calibrated by Datron. Enter the calibration uncertainty for the most-recent calibration.
- The value of TgtV_m is dependent on the Shunt/TTS Transfer Function (F_{tr}).

* Estimated

TABLE 3. SLAVE DC CURRENT

Zero and Full Range Checks

Calculate Total Measurement Uncertainty
(Enter all uncertainties in ppm)

4600 Output Measurement Uncertainties (\pm ppm of Full Range)

		4600 Output Measurement Uncertainties (\pm ppm of Full Range)								
		0A			+10A			-10A		
DCRVS Accuracy	Um									
Shunt Accuracy relative to Absolute	Ur									
Slaved 4600/4700 Accuracy relative to Cal. Stds.	Us ^[4]	24hr 50	90dy 50	1yr 52	24hr 81	90dy 104	1yr 217	24hr 81	90dy 104	1yr 217
Slaved 4600/4705 Accuracy relative to Cal. Stds.	Us ^[4]	24hr 52	90dy 52	1yr 60	24hr 88	90dy 117	1yr 245	24hr 88	90dy 117	1yr 245
Slaved 4600/4707 Accuracy relative to Cal. Stds.	Us ^[4]	24hr 50	90dy 50	1yr 50	24hr 80	90dy 102	1yr 174	24hr 80	90dy 102	1yr 174
Slaved 4600/4708 Accuracy relative to Cal. Stds.	Us ^[4]	24hr 50	90dy 50	1yr 50	24hr 80	90dy 100	1yr 170	24hr 80	90dy 100	1yr 170
Datron Cal Std uncertainty relative to Absolute	Ud ^[1]	30	30	30	30	30	30	30	30	30
User's Cal Std uncertainty relative to Absolute	Uc ^[2]									
Total Measurement Uncertainty (Validity Tolerance)	DCUt									

Calculate Validity Tolerance Limits

Value of DC Current Shunt	Rs		Ω		Ω		Ω
Target Value for Vm	TgtVm ^[3]		v		v		v
Upper Tolerance Limit for Vm	ULVm		v		v		v
Lower Tolerance Limit for Vm	LLVm		v		v		v

DMM Readings and 4700 Settings

DMM Transfer Readings		'V0' =	v	'+V1' =	v	'-V1' =	v
Actual 4700 Settings (Vm) for DMM Transfer Reading	Vm		v		v		v

Notes:

1. Use Ud only if the 4600 was last calibrated by Datron.
2. Use Uc only if the 4600 was **not** last calibrated by Datron.
Enter the calibration uncertainty for the most-recent calibration.
3. The value of TgtVm is dependent on the value Rs of the shunt.
4. Use only one value of Us: the one appropriate to the slaving calibrator in use.

TABLE 4. SLAVE AC CURRENT

Full Range Checks

Calculate Total Measurement Uncertainty (ppm)		4600 Output Measurement Uncertainties (\pm ppm of Full Range) - Verification Frequencies -								
		300Hz			5kHz			20kHz		
Total DC Measurement Uncertainty (from DC Verification)	DCU ^{t(1)}									
Slaved 4600/4700 AC Accuracy relative to Calibration Standards	ACU ^{s(5)}	24hr 520	90dy 590	1yr 820	24hr 930	90dy 1000	1yr 1220	24hr 7420	90dy 8960	1yr 10980
Slaved 4600/4705 AC Accuracy relative to Calibration Standards	ACU ^{s(5)}	24hr 630	90dy 730	1yr 940	24hr 1090	90dy 1190	1yr 1360	24hr 7620	90dy 9320	1yr 11270
Slaved 4600/4707 AC Accuracy relative to Calibration Standards	ACU ^{s(5)}	24hr 400	90dy 470	1yr 570	24hr 860	90dy 940	1yr 1030	24hr 7320	90dy 8770	1yr 10410
Slaved 4600/4708 AC Accuracy relative to Calibration Standards	ACU ^{s(5)}	24hr 340	90dy 410	1yr 470	24hr 810	90dy 870	1yr 940	24hr 7320	90dy 8720	1yr 10340
Datron AC Cal. Standard Uncert. relative to Absolute	ACU ^{d(2)}	110	110	110	110	110	110	250*	250*	250*
User's AC Cal. Standard Uncert. relative to Absolute	ACU ^{c(3)}									
Total Measurement Uncertainty (Validity Tolerance)	ACU ^t									

Calculate Validity Tolerance Limits

TTS Transfer Function	F _{tr}			
Target Value for DCIm	Tgt DCIm ⁽⁴⁾		A	A
Upper Tolerance Limit for DCIm	ULIm		A	A
Lower Tolerance Limit for DCIm	LLIm		A	A
4700 AC Current setting for Thermal Transfer Null	DCIm		A	A

Notes:

- DCU^t was calculated during the previous Slave DC verification. Ensure that the correct Cal. Std. Uncertainty (U_d or U_c) was included.
- Use ACU^d only if the 4600 was last calibrated by Datron.
- Use ACU^c only if the 4600 was **not** last calibrated by Datron. Enter the calibration uncertainty for the most-recent calibration.
- The value of TgtDCIm is dependent on the Shunt/TTS Transfer Function (F_{tr}).
- Use only one value of ACUs: the one appropriate to the slaving calibrator in use.

* Estimated

Validity Tolerance Limit Calculations

This appendix deals with the calculations necessary to determine the Validity Tolerance Limits for each of the verification procedures. Reference to the appropriate calculation is given in each procedure.

Solo Verifications

To confirm the 4600 specification it is necessary to measure its transconductance G_m , whose nominal value is 1 siemens.

$$G_m = I_{out} / V_{in}, \text{ where } V_{out} \text{ is constant.}$$

DC Current (Page RS 1-2 Table 1)

Measurement of G_m

G_m cannot be measured directly, so the method described on pages 4-5 to 4-7 employs a precision shunt (value R_s) to convert the output current into a voltage. The shunt voltage is then measured (again indirectly - via a 'transfer' procedure). The method minimizes the effects of the DMM uncertainties.

Procedural Model

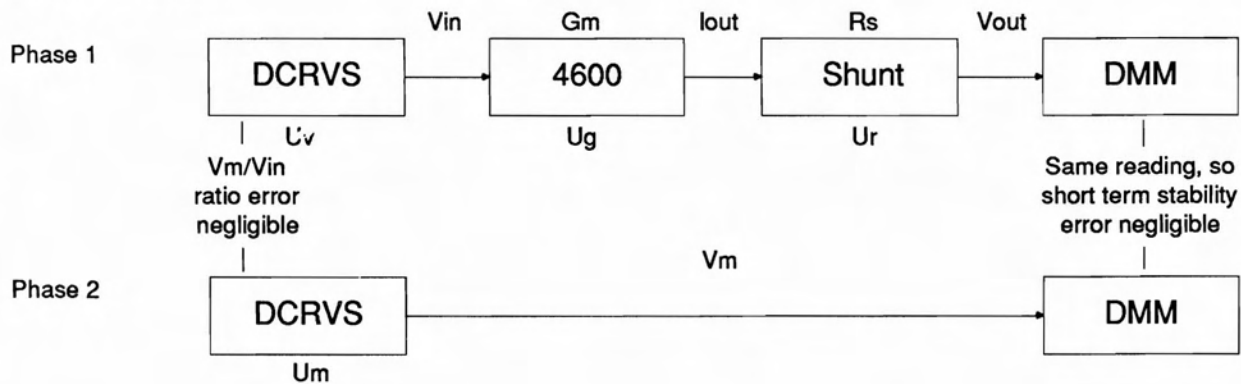

To relate Phase 1 to the value of G_m , the above equation is transposed to place V_{out} as the subject:

$$V_{out} = V_{in} \times G_m \times R_s$$

V_{out} remains constant, as in Phase 2 it is measured by adjusting the DCRVS to obtain the same DMM voltage reading. Thus the basic equation becomes:

$$V_m = V_{in} \times G_m \times R_s$$

Implicit Uncertainties

The uncertainties implicit in the above equation are as follows:

- U_v:** Traceable accuracy of the DCRVS 0V and 10V outputs relative to Absolute accuracy.
- U_m:** Traceable accuracy of the DCRVS 0V and 1V [100mV] outputs, relative to Absolute accuracy.
- U_r:** Traceable accuracy of the shunt resistance relative to Absolute accuracy.
- U_g:** Traceable accuracy of the 4600 relative to Calibration Standards.
- U_x:** Short term transfer stability of the DMM.

The calculations to find the Validity Tolerance for this equation for each of the verification points are lengthy and complicated, possibly with unrealistically-large result. But the method itself introduces two major simplifications:

1. By using the DMM only as a transfer standard, adjusting the DCRVS for the same reading during Phase 2, the accuracy required of the DMM is limited to its short-term stability.
2. By using a suitable Datron calibrator as DCRVS (as suggested in 'Equipment Requirements') the ratio error between V_{in} and V_m is very small.

Both these uncertainties are minute compared with other traceable accuracies in the equation. By assuming that they do not exist (in the interests of simplifying the calculations), the Validity Tolerance is made marginally tighter but remains well within the capability of the 4600. The calculation of Validity Tolerance and V_m Limits, detailed overleaf, makes the assumption that the suggested equipment will be used. Note that this may not be valid for other DCRVS/DMM combinations.

Validity Tolerance

The assumptions made on the previous page allow us to discard any uncertainties associated with the DMM transfer error (U_x) and the DCRVS 0V-10V accuracy (U_v). Thus we need only sum U_r and U_g , plus the uncertainties associated with the most-recent calibration of the 4600; to arrive at the validity tolerance:

Specific Uncertainties

4600 G_m

The allowed uncertainty of G_m consists of its basic accuracy specification relative to calibration standards (U_g), plus the uncertainty to absolute accuracy of its most-recent calibration. It is possible to give both of these if the instrument was last calibrated by Datron. In verification report RS 1 Table 1, the values are already entered in against U_g and U_d for the nominal verification points. For verifications after any calibration other than by Datron, then Datron's calibration uncertainty (U_d) must be replaced by the uncertainty associated the most-recent calibration (U_c). A space is provided in the table for U_c to be entered. For a verification immediately following a recalibration, using the same equipment in the same conditions, both U_d and U_c can be discarded.

R_s

The uncertainty relative to absolute accuracy associated with shunt (U_r) will need to be calculated and added to the total for G_m . This forms the total user's uncertainty for the present verification, and a space is provided in the table for it to be entered.

Summing in ppm

The total measurement uncertainty calculation is best carried out all in the same units, and for parts-per-million (ppm) it is a simple sum of the relevant uncertainties. So units such as % should be converted to ppm before summing. A space is provided for entry of the total measurement uncertainty (Validity Tolerance) DCU_t .

Upper and Lower Limits

Once the validity tolerance in ppm has been calculated for the particular verification being carried out (the interval since the last calibration is significant), the figure is applied to the target value of V_m ($TgtV_m = \text{nominal } I_{out} \times \text{nominal } R_s$), in order to determine the upper and lower voltage tolerances to be placed on the V_m setting for validity of the verification. Spaces are provided in the table to register these limits.

Measurement Results

A space is provided in the table to enter the actual V_{in} setting, for comparison with the tolerance limits.

Summary of Symbols

The symbols used in the calculations appear in Table 1 in Verification Report RS 1.

Relevant Formulae

The following formulae should be used in the different circumstances shown:

Solo DC Verification at Zero and Full Range Values

A. When the Last Calibration was by Datron:

For each 4600 OUTPUT Value calculate the Validity Tolerance Limits, using the *90dy* figures for U_g , as follows:

- First enter the user's uncertainty in ppm:

$$U_r$$

(U_g and U_d are already entered for three intervals)

- Next sum the three uncertainties:

$$U_r + U_g + U_d$$

Enter the result on the DC Current table as DCU_t .

- Determine the Target Measurement Voltage:

$$TgtV_m = I_{out} \times R_s$$

- Then calculate the Validity Tolerance Limits:

For output value +10A:

$$ULV_m = TgtV_m [1 + (DCU_t \times 10^{-6})]$$

$$LLV_m = TgtV_m [1 - (DCU_t \times 10^{-6})]$$

For output value -10A:

$$ULV_m = TgtV_m [1 - (DCU_t \times 10^{-6})]$$

$$LLV_m = TgtV_m [1 + (DCU_t \times 10^{-6})]$$

At 0A use the '0A' $TgtV_m$, the '0A' DCU_t and $+10A \times R_s$:

$$ULV_m = TgtV_m + (10A \times R_s \times DCU_t \times 10^{-6})$$

$$LLV_m = TgtV_m - (10A \times R_s \times DCU_t \times 10^{-6})$$

Enter the results as Upper and Lower Tolerance Limits for V_m respectively.

B. When the Last Calibration was not by Datron:

Use the calculations in (A), but substitute U_c for U_d .

C. Immediately Following a User-Calibration

(Same equipment, same conditions)

Use the calculations in (A), but discard both U_c and U_d , and use the 24hr specification interval figure for U_g .

Solo Verifications (Contd.)

AC Current (Page RS 1-3 Table 2)

Measurement of G_m

G_m cannot be measured directly, so the method described on pages 4-9 to 4-11 performs an AC/DC thermal transfer with precision shunt (value R_t), using the 4600 as the DC current reference source.

Procedural Model

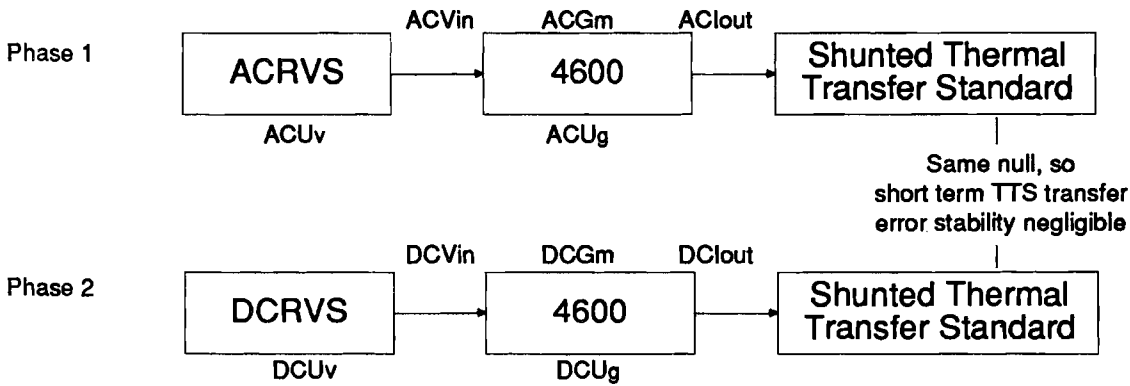

Overall Model Formula

To relate the method to the value of ACG_m; in Phase 1 the basic Solo equation is transposed to place ACI_{out} as the subject:

$$ACI_{out} = ACV_{in} \times ACG_m$$

The ACRVS is set to nominal 10V ACV_{in}. The TTS is nulled to the 4600 AC 10A output, ACI_{out} passing through the shunt.

In Phase 2, DCI_{out} is set by adjustment of DCV_{in}, to obtain the same null on the thermal transfer. Thus DCI_{out} carries the uncertainties due to ACV_{in} and ACG_m. DCI_{out} value is also affected by the DC→AC transfer function F_{tr} of the shunted TTS at each of the frequencies to be verified, so this is accounted for in the expanded equation.

$$DCI_{out} = ACV_{in} \times ACG_m / F_{tr}$$

DCI_{out} is the result of adjusting DCV_{in} such that:

$$DCI_{out} = DCV_{in} \times DCG_m$$

When the equation is expanded and transposed to make DCV_{in} the subject, we have the model formula for the method:

$$DCV_{in} = (ACV_{in} \times ACG_m) / (F_{tr} \times DCG_m)$$

The nominal value of F_{tr} is usually unity; ie. 1A(RMS)/1A(DC); any deviation from this value at the specified frequencies of 300Hz, 5kHz and 20kHz will be known from the calibration data of the Shunt/TTS. The value is used to determine the Target DC V_{in} setting (V_m)

Implicit Uncertainties

The uncertainties implicit in the above equation are as follows:

- ACU_v: Traceable accuracy of the ACRVS 10V output relative to Absolute accuracy.
- ACU_g: AC Traceable accuracy of the 4600 relative to calibration standards.
- E_{tr}: Shunt/TTS Transfer-Function Error.

The method itself introduces two major simplifications:

1. By using the verified DCRVS/4600 as the DCI source, DCU_v and DCU_g are known, and DCU_t has already been calculated.
2. By using the Shunt/TTS only as a transfer standard, adjusting the DCRVS for the same reading during Phase 2, the accuracy required of the transfer is limited to its short-term stability.

This uncertainty is minute compared with other traceable accuracies in the equation. By assuming that it does not exist (in the interests of simplifying the calculations), the Validity Tolerance is made marginally tighter but remains well within the capability of the 4600.

The calculation of Validity Tolerance and V_m Limits, detailed overleaf, makes the assumption that the suggested equipment will be used. Note that this may not be valid for other ACRVS/DCRVS/Shunt/TTS combinations.

Validity Tolerance

The assumptions made on the previous page allow us to discard any uncertainties associated with the Shunt/TTS transfer error (E_{tr}). Thus we need only sum DCU_t , DCU_v , ACU_v and ACU_g , plus the uncertainties associated with the most-recent AC calibration of the 4600; to arrive at the validity tolerance:

Specific Uncertainties

4600 AC Gm

The allowed uncertainty of G_m consists of its basic accuracy specification relative to calibration standards (ACU_g), plus the uncertainty to absolute accuracy of its most-recent calibration. It is possible to give both of these if the instrument was last calibrated by Datron. In verification report RS 1 Table 2, the values are already entered against ACU_g and ACU_d at the verification frequencies. For verifications after any calibration other than by Datron, then Datron's calibration uncertainty (ACU_d) must be replaced by the uncertainty associated the most-recent calibration (ACU_c). A space is provided in the table for ACU_c to be entered. For a verification immediately following a recalibration, using the same equipment in the same conditions, both ACU_d and ACU_c can be discarded.

ACV_{in} and previous DC Verification

The uncertainties relative to absolute accuracy associated with the ACRVS (ACU_v) will need to be calculated and added to the total for the AC Gm. These two, plus the total DC uncertainty of DCU_v (DCU_t - see the previous page) form the total uncertainty ACU_t for the present verification, and spaces are provided in the table for them to be entered.

Summing in ppm

The total measurement uncertainty calculation is best carried out all in the same units, and for parts-per-million (ppm) it is a simple sum of the relevant uncertainties. So units such as % should be converted to ppm before summing. A space is provided for entry of the total measurement uncertainty ACU_t .

Upper and Lower Limits

N.B. The DCRVS setting required to provide the correct DCV_{in} for the TTS null is given the symbol V_m , as it is this setting which is measured against the uncertainty tolerance limits.

Once the validity tolerance in ppm has been calculated for the particular verification being carried out (the interval since the last calibration is significant), the figure is applied to the target value of V_m ($TgtV_m = \text{nominal } DCV_{in} / \text{nominal } F_{tr}$), in order to determine the upper and lower voltage tolerances to be placed on the V_m setting for validity of the verification. Spaces are provided in the table to register these limits.

Measurement Results

A space is provided in the table to enter the actual V_m setting, for comparison with the tolerance limits.

Summary of Symbols

The symbols used in the calculations appear in Table 2 in Verification Report RS 1.

Relevant Formulae for Solo AC Verification at Full Range Value

(10A RMS at three frequencies)

A. When the Last Calibration was by Datron:

For each 4600 OUTPUT Frequency (300Hz, 5kHz and 20kHz) calculate the Validity Tolerance Limits, using the *90dy* figures for ACU_g , as follows:

- First enter the three user's uncertainties in ppm:

DCU_t , DCU_v and ACU_v

(ACU_g and ACU_d are already entered for three intervals)

- Next sum the five uncertainties:

$DCU_v + DCU_t + ACU_v + ACU_g + ACU_d$

Enter the result on the AC Current table as **ACU_t** .

- Determine the Target Measurement Voltage for each of the three frequencies:

$TgtV_m = \text{nominal } ACV_{in} / \text{nominal } F_{tr}$

- Then calculate the Validity Tolerance Limits at each frequency:

$ULV_m = TgtV_m [1 + (ACU_t \times 10^{-6})]$

$LLV_m = TgtV_m [1 - (ACU_t \times 10^{-6})]$

Enter the results in the AC Current table as Upper and Lower Tolerance Limits for V_m respectively.

B. When the Last Calibration was not by Datron:

Use the calculations in (A), but substitute ACU_c for ACU_d .

C. Immediately Following a User-Calibration

(Same equipment, same conditions)

Use the calculations in (A), but discard both ACU_c and ACU_d , and use the 24hr specification interval figure for ACU_g .

Validity Tolerance Limit Calculations (Contd)

Slave Verifications

N.B. In this description, reference to a '4700' refers also to a compatible model 4705, 4707 or 4708.

To confirm the 4600 specification it is necessary to measure I_{out} , for a nominal 4700 OUTPUT setting of 10A.

DC Current (Page RS 1-2 Table 1)

Measurement of I_{out}

I_{out} cannot be measured directly, so the method described on pages 4-13 to 4-15 employs a precision shunt (value R_s) to convert the output current into a voltage. The shunt voltage is then measured (again indirectly - via a 'transfer' procedure). The method minimizes the effects of the DMM uncertainties.

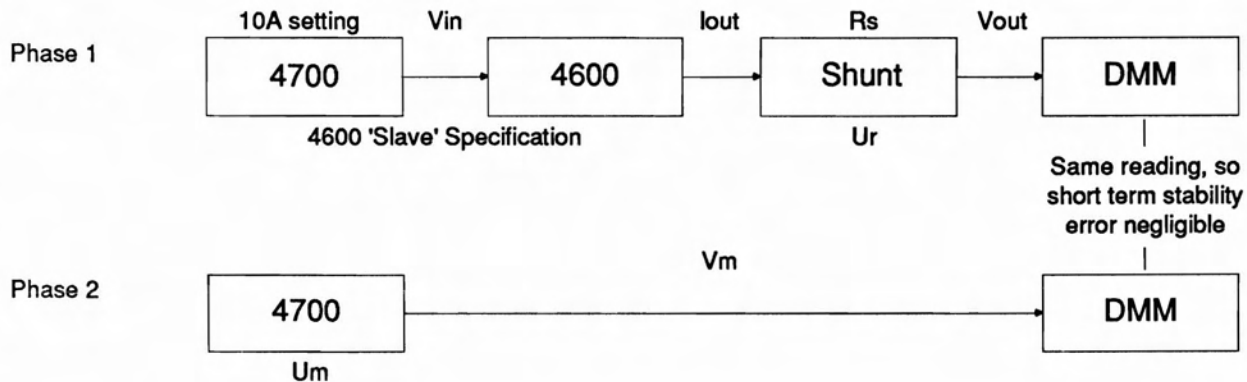

Procedural Model

To relate Phase 1 to the Slave Error, the basic equation places V_{out} as the subject:

$$V_{out} = 10A \times \text{Slave Error} \times R_s$$

V_{out} remains constant, as in Phase 2 it is measured by adjusting the 4700 voltage V_m to obtain the same DMM voltage reading. Thus the basic equation becomes:

$$V_m = 10A \times \text{Slave Error} \times R_s$$

Implicit Uncertainties

The uncertainties implicit in the above equation are as follows:

- Us: Traceable accuracy of the Slaved 0A and 10A outputs relative to Absolute.
- Um: Traceable accuracy of the 4700 0V and 1V [100mV] outputs, relative to Absolute.
- Ur: Traceable accuracy of the shunt resistance relative to Absolute accuracy.
- Ux: Short term transfer stability of the DMM.

Simplifications

The calculations to find the Validity Tolerance for this equation for each of the verification points are lengthy and complicated, possibly with unrealistically-large result. But the method itself introduces a major simplification:

By using the DMM only as a transfer standard, adjusting the 4700 for the same reading during Phase 2, the accuracy required of the DMM is limited to its short-term stability U_x .

This uncertainty is minute compared with other traceable accuracies in the equation. By assuming that U_x does not exist (in the interests of simplifying the calculations), the Validity Tolerance is made marginally tighter but remains well within the capability of the 4600. The calculation of Validity Tolerance and V_m Limits, detailed overleaf, makes the assumption that the suggested method will be used.

Validity Tolerance

The assumptions made on the previous page allow us to discard any uncertainties associated with the DMM transfer error (U_x). Thus we need only sum U_s , U_m and U_r , plus the uncertainties associated with the most-recent calibration of the 4600 and 4700; to arrive at the validity tolerance:

Specific Uncertainties

4600/4700 Slaved Combination

The allowed uncertainty of the slaved combination consists of the basic accuracy specification relative to calibration standards (U_s), plus the uncertainty to absolute accuracy of the most-recent calibration. It is possible to give both of these if the instrument was last calibrated by Datron. In verification report RS 1 Table 3, the values are already entered against U_s and U_d for the nominal verification points. For verifications after any calibration other than by Datron, then Datron's calibration uncertainty (U_d) must be replaced by the uncertainty associated the most-recent calibration (U_c). A space is provided in the table for U_c to be entered. For a verification immediately following a recalibration, using the same equipment in the same conditions, both U_d and U_c can be discarded.

R_s & U_m

The uncertainties relative to absolute accuracy associated with the shunt (U_r) and with the measurement voltage V_m (U_m) will need to be calculated and added to the total for the slaved combination. U_r , U_m and U_s form the total user's uncertainty for the present verification, and spaces are provided in the table for them to be entered.

Summing in ppm

The total measurement uncertainty calculation is best carried out all in the same units, and for parts-per-million (ppm) it is a simple sum of the relevant uncertainties. So units such as % should be converted to ppm before summing. A space is provided for entry of the total measurement uncertainty.

Upper and Lower Limits

Once the validity tolerance in ppm has been calculated for the particular verification being carried out (the interval since the last calibration is significant), the figure is applied to the target value of V_m ($TgtV_m = \text{nominal } I_{out} \times \text{nominal } R_s$), in order to determine the upper and lower voltage tolerances to be placed on the V_m setting for validity of the verification. Spaces are provided in the table to register these limits.

Measurement Results

A space is provided in the table to enter the actual V_m setting, for comparison with the tolerance limits.

Summary of Symbols

The symbols used in the calculations appear in the Table 3 in Verification Report RS1.

Relevant Formulae

The following formulae should be used in the different circumstances shown:

Slave DC Verification at Zero and Full Range Values

A. When the Last Calibration was by Datron:

For each 4600 OUTPUT Value calculate the Validity Tolerance Limits, using the *90dy* figures for U_s , as follows:

- First enter the measurement voltage and shunt uncertainties in ppm:

$$U_m \text{ and } U_r$$

(U_s and U_d are already entered for three intervals)

- Next sum the four uncertainties:

$$U_r + U_s + U_d + U_m$$

Enter the result on the DC Current table as DCUt.

- Determine the Target Measurement Voltage:

$$TgtV_m = \text{nominal } I_{out} \times R_s$$

- Then calculate the Validity Tolerance Limits:

For output value +10A:

$$\begin{aligned} ULV_m &= TgtV_m [1 + (DCUt \times 10^{-6})] \\ LLV_m &= TgtV_m [1 - (DCUt \times 10^{-6})] \end{aligned}$$

For output value -10A:

$$\begin{aligned} ULV_m &= TgtV_m [1 - (DCUt \times 10^{-6})] \\ LLV_m &= TgtV_m [1 + (DCUt \times 10^{-6})] \end{aligned}$$

At 0A use the '0A' $TgtV_m$, the '0A' U_t and $+10A \times R_s$:

$$\begin{aligned} ULV_m &= TgtV_m + (10A \times R_s \times DCUt \times 10^{-6}) \\ LLV_m &= TgtV_m - (10A \times R_s \times DCUt \times 10^{-6}) \end{aligned}$$

Enter the results as Upper and Lower Tolerance Limits for V_m respectively.

B. When the Last Calibration was not by Datron:

Use the calculations in (A), but substitute U_c for U_d .

C. Immediately Following a User-Calibration (Same equipment, same conditions)

Use the calculations in (A), but discard both U_c and U_d , and use the 24hr specification interval figure for U_s .

Slave Verifications (Contd.)**AC Current (Page RS 1 Table 4)****Measurement of ACIout**

ACIout cannot be measured directly, so the method described on pages 4-17 to 4-19 performs an AC/DC thermal transfer with precision shunt (value Rt), using the slaved 4700/4600 as the DC current reference source.

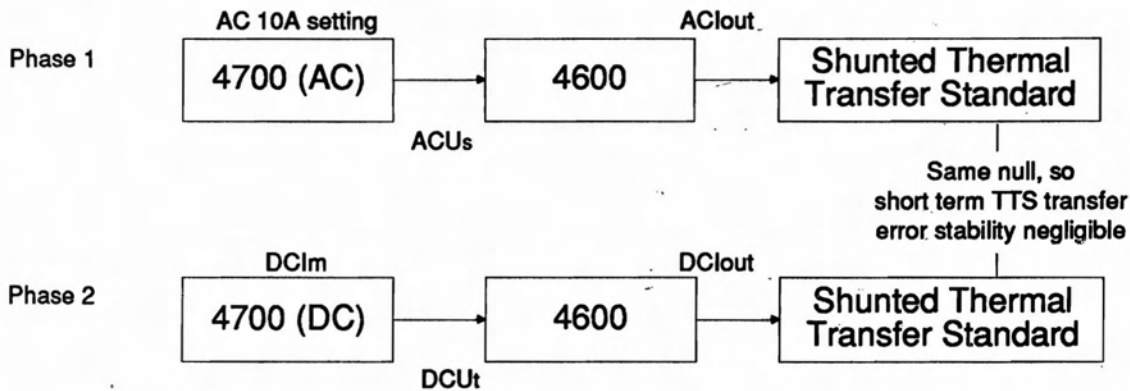
Procedural Model**Overall Model Formula**

To relate Phase 1 to the AC Slave Error, the basic equation places ACIout as the subject:

$$\text{ACIout} = 10\text{A} \times \text{AC Slave Error}$$

The 4700 is set to nominal 10A. The TTS is nulled to the 4600 AC 10A output, ACIout passing through the shunt.

In Phase 2, DCIout is set by adjustment of DCIm, to obtain the same null on the thermal transfer. Thus DCIout carries the uncertainties due to the 4700 reference voltage output and the 4600 transconductance. DCIout value is also affected by the DC→AC transfer function Ftr of the shunted TTS at each of the frequencies to be verified, so this is accounted for in the expanded equation.

$$\text{DCIout} = 10\text{A} \times \text{AC Slave Error} / \text{Ftr}$$

DCIout is the result of adjusting DCVin such that:

$$\text{DCIout} = \text{DCIm} \times \text{DC Slave Error}.$$

When the equation is expanded and transposed to make DCIm the subject, we have the model formula for the method:

$$\text{DCIm} = (10\text{A} \times \text{AC Slave Error}) / (\text{Ftr} \times \text{DC Slave Error})$$

The nominal value of Ftr is usually unity; ie. 1A(RMS)/1A (DC); any deviation from this value at the specified frequencies of 300Hz, 5kHz and 20kHz will be known from the calibration data of the Shunt/TTS. The value is used to determine the 4700 Target Current OUTPUT setting (TgtACIm).

Implicit Uncertainties

The uncertainties implicit in the above equation are as follows:

- ACUs: Traceable accuracy of the slaved 4700/4600 10A output relative to Absolute accuracy.
- DCUt: Total Traceable accuracy of the slaved 4700/4600 DC verification at 10A.
- Etr: Shunt/TTS Transfer-Function Error.

The method itself introduces two major simplifications:

1. By using the verified slaved 4700/4600 as the DCI source, DCUt has already been calculated.
2. By using the Shunt/TTS only as a transfer standard, adjusting the slaved 4700/4600 DCI OUTPUT for the same reading during Phase 2; the accuracy required of the transfer is limited to its short-term stability.

This uncertainty is minute compared with other traceable accuracies in the equation. By assuming that it does not exist (in the interests of simplifying the calculations), the Validity Tolerance is made marginally tighter but remains well within the capability of the 4600.

The calculation of Validity Tolerance and DCIm Limits, detailed overleaf, makes the assumption that the suggested method will be used.

Validity Tolerance

The assumptions made on the previous page allow us to discard uncertainties associated with the Shunt/TTS transfer error (E_{tr}). Thus we need only sum DCU_t and ACU_s , plus the uncertainties associated with the most-recent AC calibration of the 4600 and 4700; to arrive at the validity tolerance:

Specific Uncertainties

4600/4700 Slaved Combination

The allowed uncertainty of the slaved combination consists of its basic accuracy specification relative to calibration standards (ACU_s), plus the uncertainty to absolute accuracy of its most-recent calibration. It is possible to give both of these if the instrument was last calibrated by Datron. In the verification report RS 1 Table 4, the values are already entered against ACU_s and ACU_d at the verification frequencies. For verifications after any calibration other than by Datron, then Datron's calibration uncertainty (ACU_d) must be replaced by the uncertainty associated the most-recent calibration (ACU_c). A space is provided in the table for ACU_c to be entered. For a verification immediately following a recalibration, using the same equipment in the same conditions, both ACU_d and ACU_c can be discarded.

Components of the Validity Tolerance

The total DC measurement uncertainty (DCU_t - see previous page), plus ACU_s and either ACU_d or ACU_c , account for the total measurement uncertainty ACU_t (Validity Tolerance) for the present verification.

Summing in ppm

The total measurement uncertainty calculation is best carried out all in the same units, and for parts-per-million (ppm) it is a simple sum of the relevant uncertainties. So units such as % should be converted to ppm before summing. A space is provided for entry of the total measurement uncertainty ACU_t .

Upper and Lower Limits

N.B. The 4700 DC 10A range output setting required to provide the correct output current for the TTS null is given the symbol DCI_m , as it is this setting which is measured against the uncertainty tolerance limits.

Once the ACU_t has been calculated in ppm for the particular verification being carried out (the interval since the last calibration is significant), the figure is applied to the target value of DCI_m ($TgtDCI_m = \text{nominal } ACI_{out} / \text{nominal } Fr$), in order to determine the upper and lower voltage tolerances to be placed on the DCI_m setting for validity of the verification. Spaces are provided in the table to register these limits.

Measurement Results

A space is provided in the table to enter the actual DCI_m setting which gives TTS null, for comparison with the tolerance limits.

Summary of Symbols

The symbols used in the calculations appear in Tables 4 in Verification Report RS 1.

Relevant Formulae for Slave AC Verification at Full Range Value

(10A RMS at three frequencies)

A. When the Last Calibration was by Datron:

For each 4600 OUTPUT Frequency (300Hz, 5kHz and 20kHz) calculate the Validity Tolerance Limits, using the *90dy* figures for ACU_s , as follows:

- First enter the total DC uncertainty in ppm:

DCU_t

(ACU_s and ACU_d are already entered for three intervals)

- Next sum the three uncertainties:

$DCU_t + ACU_s + ACU_d$

Enter the result on the AC Current table as ACU_t .

- Determine the Target Measurement Voltage for each of the three frequencies:

$TgtDCI_m = \text{nominal } ACI_{out} / \text{nominal } Fr$

- Then calculate the Validity Tolerance Limits at each frequency:

$ULI_m = TgtDCI_m [1 + (ACU_t \times 10^{-6})]$

$LLI_m = TgtDCI_m [1 - (ACU_t \times 10^{-6})]$

Enter the results in the AC Current table as Upper and Lower Tolerance Limits for DCI_m respectively.

B. When the Last Calibration was not by Datron:

Use the calculations in (A), but substitute ACU_c for ACU_d .

C. Immediately Following a User-Calibration (Same equipment, same conditions)

Use the calculations in (A), but discard both ACU_c and ACU_d , and use the 24hr specification interval figure for ACU_g .

Uncertainty and Traceability

Appendix 2 to:
4600 User's Handbook
Section 4

Cumulative Tolerances

If an instrument was correctly calibrated against the factory standard at its uncertainty limit, and then verified against a user's standard, also at its limit; there are two extremes to the range of traceable results which could be obtained. If, for example, both standards' traceable errors were equal and in the same sense, the instrument would appear to verify as absolutely accurate. But if the errors were in opposite sense, it could appear to be inaccurate by the sum of the two limits of uncertainty.

In the following numerical example, a 4600 is verified in the factory at 10A, and with 0ppm error against a 5ppm-high standard (relative to Absolute Accuracy):



It remains correctly calibrated, and could be delivered to one of two users: one user's standard is 5ppm higher than Absolute, and the other's is 5ppm lower.

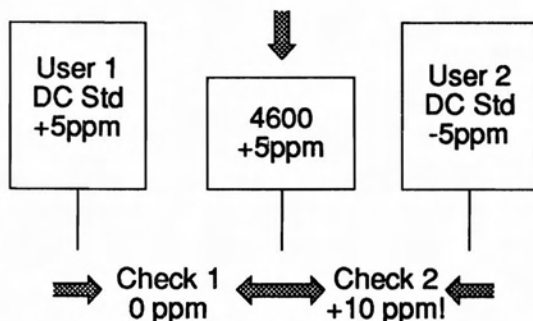

Despite the instrument sustaining its original accuracy of +5ppm, and the standards all being within 5ppm of Absolute; the first user would verify the 4600 as having 0ppm error, but the second would obtain an error of +10ppm.

The increased uncertainty is unavoidable unless the same standard is used for each verification. This is clearly not a practical proposition following delivery. But after the first autocalibration against the user's standard, Datron's calibration uncertainty no longer applies.

Verification Uncertainties

Each element in the calibration traceability chain (on the next page) contributes its uncertainty to influence the overall verification tolerance limits. All uncertainties must be accounted for when calculating the total tolerances.

In addition, if two separate systems are used, one for calibration and the other for verification, then the cumulative total tolerance ('Validity Tolerance') is the sum of those established for each system (as described earlier).

Thus on receipt of the 4600, Datron's uncertainties must be included in the total tolerance limits; but when verifying against the same Standards setup used to calibrate the instrument, they are excluded.

Two formulae for calculating the total tolerance limits are given for each procedure, covering the two types of verification occasions mentioned.

Validity Tolerance Limit Calculations

The 4600 is verified by comparing its transconductance with the Validity (Total) Tolerance Limits. These have to be calculated by summing the appropriate uncertainties from the traceability chain, and expressing the result in upper and lower absolute deviations from the chosen verification value. The 4600 checks out if its measured transconductance is between the limits.

Where possible, the 4600 specification and Datron calibration uncertainties are given in a form suitable for calculation (see Report Sheet RS 1 where actual uncertainties are entered). Where this is not possible they can be assembled from the specifications in Section 6 (refer to Appendix 1).

User's uncertainties need to be assembled and included, expressed in the form appropriate to the calculations.

Whereas Datron's uncertainties are normally included in the calculations only once (on receipt), user's uncertainties must always be included. So it is sensible to provide a permanent record, eg on Report Sheets.

Once the relevant uncertainties have been entered on the Report Sheet, the Validity Tolerance Limits can be calculated. The correct calculations are identified in the individual procedures.

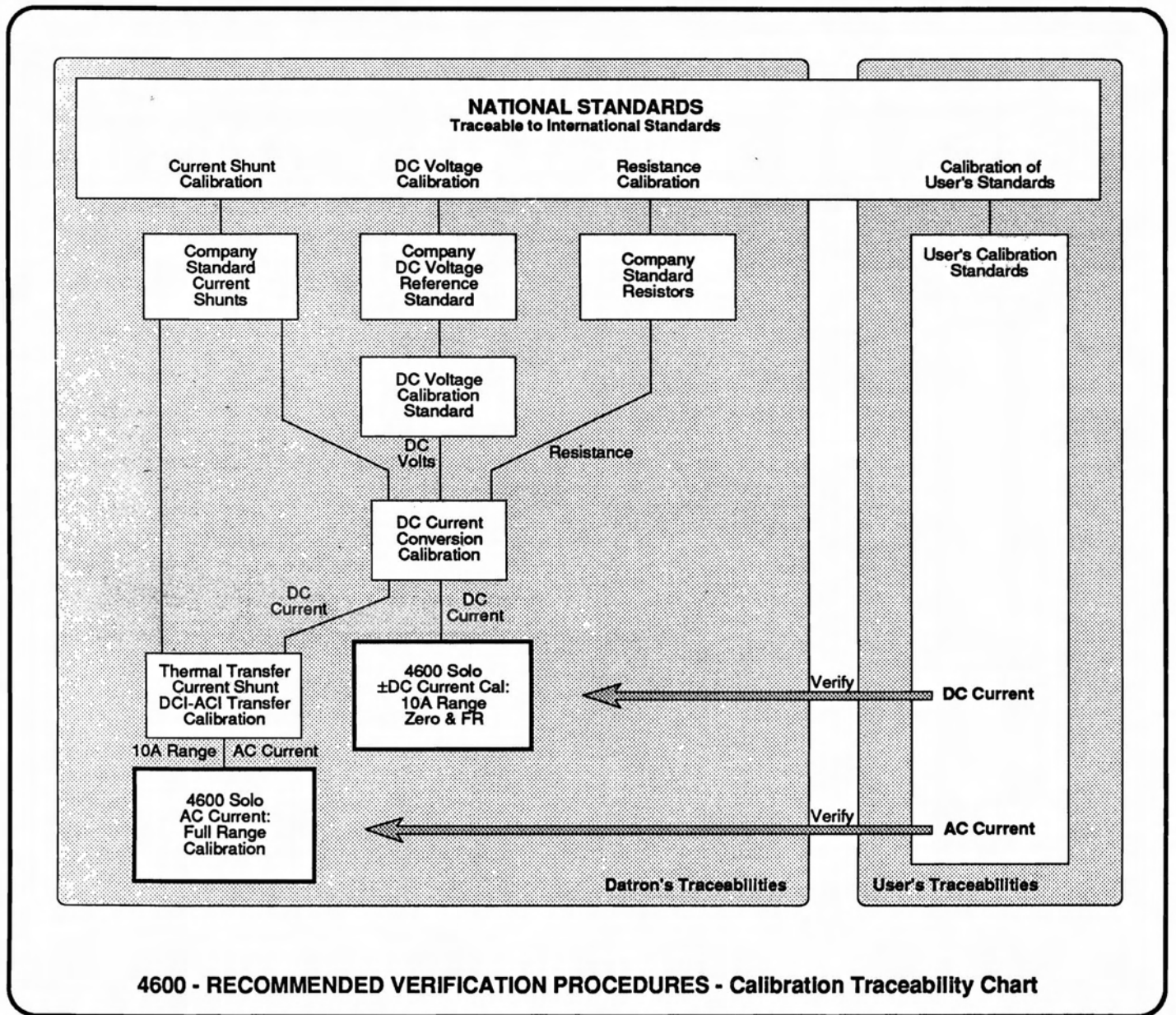

General Procedural Information

Appendix 3 to:
4600 User's Handbook
Section 4

Specifications and Verification

4600 Specification Formats

The specifications can be found in two forms:

a. Tabular layout as in Section 4.

In Section 4, the stability and relative accuracy specifications alone describe the true performance of the instrument, in a form which can be made traceable to National Standards merely by adding in the uncertainty of the reference standards used for checking. Datron's calibration uncertainty is shown in a separate column. This must be added, to obtain true traceable accuracy for all instruments which were last calibrated by Datron. For instruments calibrated by other agencies, their own calibration uncertainty must be added instead.

b. Slave Mode Specifications stored within the slaving 4700-series calibrator's non-volatile memory.

The 4600's non-volatile memory figures can be accessed using the 'Spec' Mode of the slaving 4700-series calibrator. These are compiled specifically for users without verification facilities, so that they can obtain the tolerance limits of the 4600 output, without referring to Section 4.

The position of the CAL INTERVAL switch on the calibrator's rear panel selects the readout for the intervals listed below. The '90-day' and '1-year' readouts always include Datron's own calibration uncertainty relative to National Standards, giving traceable accuracies for instruments which were last calibrated by Datron.

For AC Current, the output is specified in four frequency bands:

10Hz - 1kHz; 1kHz - 5kHz; 5kHz - 10kHz
and 10kHz - 20kHz.

The Spec mode readout also aligns to these three bands.

24hr CALIBRATION INTERVAL

24 Hours Stability figure only, relative to Calibration Standards.

90dy CALIBRATION INTERVAL

90 Days Relative Accuracy figure plus Datron's Calibration Uncertainty relative to National Standards.

1yr CALIBRATION INTERVAL

1 Year Relative Accuracy figure plus Datron's Calibration Uncertainty relative to National Standards.

Because the 4600 operates in two modes and for DC and AC, the Report Sheets are subdivided into tables each relating to a particular verification technique for the combinations.

Verification Conditions

Stability Specifications

The 24-hour stability specifications are relative to user's reference standards. In all cases validity depends on using the same standard as reference, under the same conditions, including temperature. Also, verification is valid only within 24 hours of calibration or a previous verification. In the latter case, the specifications are relative to the figures obtained at the earlier verification.

On Receipt

The 90-day and 1-year accuracy specification periods start from the date of final test on the certificate of conformance. The 90-day and 1-year tolerances can be calculated by adding both the user's reference standard absolute uncertainty and Datron's calibration absolute uncertainty to the Relative Accuracy figure given in the Report Sheets.

Following User Calibration or a Previous Verification

Add only the user's uncertainty to the Relative Accuracy figure.

Temperature

Where ambient temperatures are outside the Specified range, temperature coefficient correction should be taken into account.

Uncertainties in Verification

Appendix 2 describes the uncertainties inherent in any verification process. Worst-case figures must always be assumed, although accumulated uncertainty is generally much less than implied.

Duplicate the Report Sheets

Please use the printed report sheets as masters to generate duplicate copies, then record the instrument's performance on the duplicates (both on receipt from Datron and for future periodic checks).

The report sheets list the appropriate accuracy limits and Datron's calibration uncertainty (relative to Absolute Accuracy) at the verification points. Blank columns are provided for the user's calibration uncertainty, the cumulative 'Validity' tolerance limits, and the DC Voltage Source's adjusted reading (for comparison with the tolerance).

Page 1 of Report Sheet RS1 is assigned to guidance for those users who are unfamiliar with the Verification process.

The appropriate limit calculations appear in Appendix 1.

Thermal Transfer

(AC Current)

When verifying the 4600, the Thermal Transfer Standard is connected to the 4600 output terminals via a shunt, and the AC output is compared with the DC output.

Important Points when using a Thermal Transfer Standard:

- **Start with OUTPUT OFF.**

The 4600 should be connected to the Thermal Transfer Standard only when the 4600 OUTPUT OFF LED is lit. (With Output **OFF**, the I+ and I- terminals are at high impedance).

- **Sensitivity.**

Always set the Thermal Transfer Standard to its lowest sensitivity before connecting up. Increase sensitivity when necessary to obtain the required input level.

Alternative AC Current Verification

(Using an AC DMM for AC - AC Transfer instead of a Thermal Transfer Standard)

Appendix 4 to:
4600 User's Handbook
Section 4

References

Validity Tolerance Calculations

The verification processes are modelled later in this appendix, together with the validity tolerance limit calculations, starting on page 4-A4-9.

Report Sheets

The Report Sheets RS 2 for the alternative solo and slave procedures are given at the end of this appendix, starting on page 4-A4-RS2-1.

Shunt Values

In this appendix, in the interests of clarity, an assumption is made that a 100mΩ shunt will be used. The shunt value and shunt voltage values are given for a 100mΩ shunt; values for a 10mΩ shunt are indicated by square braces [...].

Solo Mode

Full Range Checks

The Solo 4600 is verified by measuring its transconductance. We use the ACRVS to input a voltage, and compare the output current value against the input voltage value. A shunt converts the output current to a voltage, measured across the shunt using a DMM.

The ACRVS output is then connected directly to the DMM and adjusted to give the same reading as for the shunt voltage. The output setting of the ACRVS is compared against calculated limits.

This AC - AC transfer ensures that the DMM uncertainties are reduced to negligible levels.

Equipment Requirements

- An AC Reference Voltage Source (ACRVS), calibrated to suitable accuracy for frequencies of 300Hz, 5kHz and 20kHz at 10V and 1V [100mV] RMS.
Example: Datron 4200A, 4700 or 4708.
- A Calibrated 10A AC Current Shunt of suitable accuracy, of value 100mΩ [10mΩ].
- A DMM of sufficient resolution and stability, for use as a transfer device to measure the AC voltage across the shunt.
Example: Datron 1281, 1081 or 1071 with Option 10.

CAUTION

Ensure that the shunt's rated power dissipation is sufficient to avoid permanent degradation from the self-heating effects of the current being checked.

Summary of AC Procedure

General

The 4600 is verified at 10A RMS for three output frequencies: 300Hz, 5kHz and 20kHz, corresponding to an input voltage of 10V at the same frequencies. The 4600 output is passed through a calibrated precision AC current shunt of value 100mΩ [10mΩ]; the resulting voltages are measured by an AC - AC transfer method, using a DMM.

4600 AC Output Current Measurement

The specification of the AC Reference Voltage Source (ACRVS) should be known to verify at the voltages and frequencies to be used. Its output is applied to the Solo 4600 INPUT terminals. The OUTPUT I+ and I- terminals of the 4600 are connected to pass the current through the shunt, and the DMM is connected to measure the voltage across the shunt. The ACRVS output voltage is set to the three verification points in turn, and the DMM readings are noted.

AC - AC Transfer

The ACRVS output is then connected directly to the DMM input terminals, with the shunt connection removed.

For each frequency, the ACRVS output voltage setting is adjusted in turn to give the same DMM voltage readings obtained across the shunt. For each frequency the ACRVS output setting is recorded. The accumulated uncertainties are recorded and used to calculate the Validity Tolerance Limits. The 4600 is verified if the ACRVS output settings are within these tolerance limits.

Preparation

Before attempting any verification ensure that the following steps have been carried out.

1. Before connecting and operating any equipment, consult the manufacturers' handbooks.
2. Ensure that the ACRVS and DMM specifications verify for frequencies of 300Hz, 5kHz and 20kHz; at the following voltages:
ACRVS 1V [100mV] RMS; 10V RMS.
DMM 1V [100mV] RMS.
3. Turn on the ACRVS, DMM and 4600 to be checked and allow at least 2 hours' warm-up in the specified environment.
4. Ensure that the ACRVS and 4600 Outputs are OFF.
5. The 4600 front panel LEDs should show no errors present. Carry out any self-test routine on the ACRVS.

The procedure is detailed on pages 4-A4-2/3.

Solo AC Current Verification Procedure

Record results on Report Sheet 4600 RS 2, (Pages 4-A4-RS2-1 & 2)

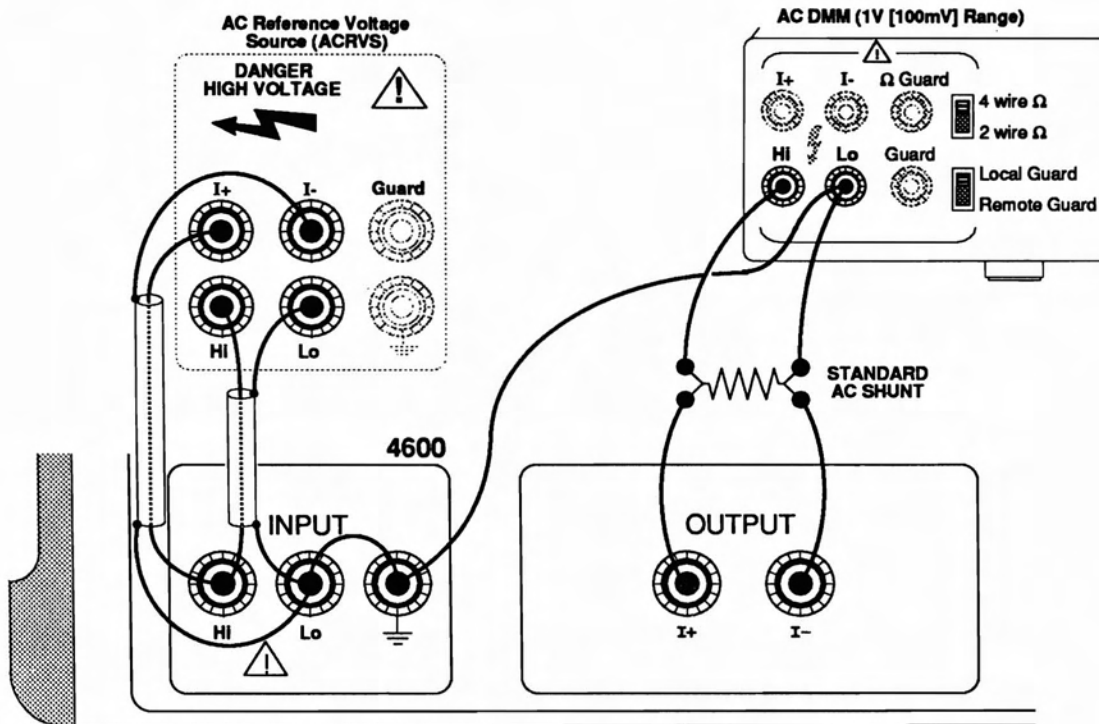

Output Current Measurement

Connect the ACRVS, 4600, Shunt and DMM as shown in the above diagram (ensure the connection of DMM Lo to the 4600 INPUT ground).

Carry out operations (a) to (l):

- | | | | | | |
|----|-------|---|----|-------|---|
| a. | ACRVS | Ensure that OUTPUT is OFF, FUNCTION to AC Voltage, FREQUENCY to 300Hz, OUTPUT RANGE to 10V, Sense to Remote. Guard to Local. OUTPUT voltage to 10.00000V RMS. | f. | ACRVS | Reset FREQUENCY to 5kHz. |
| b. | DMM | Set AC range to measure 1V [100mV] RMS. Set Guard to Local. | g. | DMM | Record the DMM reading on RS2 Table 1 against 'DMM Transfer Reading' as 'V5k'. |
| c. | ACRVS | Set OUTPUT ON. | h. | ACRVS | Reset FREQUENCY to 20kHz. |
| d. | 4600 | Set OUTPUT ON. | j. | DMM | Record the DMM reading on RS2 Table 1 against 'DMM Transfer Reading' as 'V20k'. |
| e. | DMM | Record the DMM reading on RS2 Table 1 against 'DMM Transfer Reading' as 'V300'. | k. | 4600 | Set OUTPUT OFF. |
| | | | l. | ACRVS | Set OUTPUT OFF. |

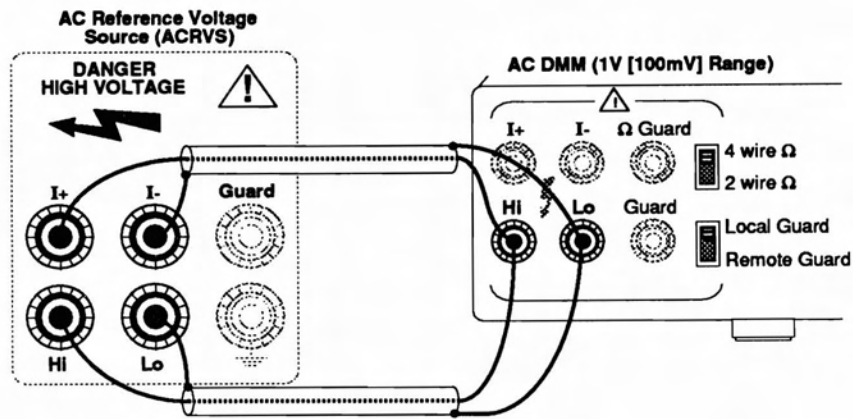

AC - AC Transfer

Connect the DMM to read the ACRVS output as in the above diagram. Ensure that the DMM Guard is set to **Local**.

Carry out operations (m) to (s):

- m. ACRVS Ensure that OUTPUT is OFF,
FUNCTION to AC Voltage,
FREQUENCY to 300Hz
OUTPUT RANGE to 1V [100mV],
Sense to Remote.
Guard to Local.
- n. DMM Set AC range to measure 1V [100mV] RMS.
- p. ACRVS Set OUTPUT ON.
Adjust the ACRVS output voltage to give a DMM
reading of 'V300'.
Record the ACRVS output voltage setting
against 'Vm' in the 300Hz column of the Report
Sheet RS 2 Table 1.
- q. ACRVS Set FREQUENCY to 5kHz.
Adjust the ACRVS output voltage to give a DMM
reading of 'V5k'.
Record the ACRVS output voltage setting
against 'Vm' in the 5kHz column of the Report
Sheet RS 2 Table 1.
- r. ACRVS Set FREQUENCY to 20kHz.
Adjust the ACRVS output voltage to give a DMM
reading of 'V20k'.
Record the ACRVS output voltage setting
against 'Vm' in the 20kHz column of the Report
Sheet RS 2 Table 1.
Set OUTPUT OFF.

Validity Tolerance Limit Calculations

Refer to Appendix 1 page 4-A4-9.

- s. Calculate the Lower and Upper Vm Tolerance Limits.
 - Use Calculation A if the 4600 was last calibrated by Datron.
 - Use Calculation B if the 4600 was last calibrated against the standards being used for verification.
 - Use Calculation C if the verification immediately follows a calibration using the same equipment.
 - The Solo Full Range AC outputs verify if the value of Vm recorded in (p), (q) and (r) are at or between the corresponding Validity Tolerance Limits.

Alternative AC Current Verification (Contd)

(Using an AC DMM for AC - AC Transfer instead of a Thermal Transfer Standard)

Slave Mode

N.B. In this description and procedure, reference to a '4700' refers also to a compatible model 4705, 4707 or 4708.

Full Range Checks

The slaved 4600 is verified by measuring its output. We compare the output current value against the 4700 OUTPUT setting. A shunt converts the output current to a voltage, measured across the shunt using a DMM.

The 4700 output voltage is then connected directly to the DMM and adjusted to give the same reading as for the shunt voltage. The output setting of the 4700 is compared against calculated limits.

This AC - AC transfer ensures that the DMM uncertainties are reduced to negligible levels.

Equipment Requirements

- The slaving 4700, AC voltage verified to suitable accuracy for frequencies of 300Hz, 5kHz and 20kHz at 10V and 1V [100mV] RMS, and previously calibrated in Slave mode with the 4600 to be verified.
- A Calibrated 10A AC Current Shunt of suitable accuracy, of value 100m Ω [10m Ω].
- A DMM of sufficient resolution and stability, for use as a transfer device to measure the AC voltage across the shunt.
Example: Datron 1281, 1081 or 1071 with Option 10.

CAUTION

Ensure that the shunt's rated power dissipation is sufficient to avoid permanent degradation from the self-heating effects of the current being checked.

Summary of AC Procedure

General

The 4700/4600 combination is verified at 10A RMS for three output frequencies: 300Hz, 5kHz and 20kHz. The 4600 output passes through a precision AC current shunt of value 100m Ω [or 10m Ω]; the resulting voltages are measured by an AC - AC transfer method, using a DMM.

4600 Output Current Measurement

The specification of the 4700 AC voltage output should be known to verify at the voltages and frequencies to be used. The 4600 is connected in Slave mode to the 4700. The OUTPUT I+ and I- terminals of the 4600 are connected to pass the output current through the shunt, with the DMM connected to measure the shunt voltage. The 4700 AC 10A OUTPUT RANGE is selected. Its OUTPUT display is set to Full Range 10A for each frequency in turn, and the DMM readings are noted.

AC - AC Transfer

The 4700 voltage output is then connected directly to the DMM input terminals, with the shunt connection removed.

For each frequency, the 4700 OUTPUT voltage is adjusted to give the same DMM voltage readings obtained across the shunt. For each frequency the 4700 OUTPUT display setting is recorded. The accumulated uncertainties are recorded and used to calculate the Validity Tolerance Limits. The combination is verified if the 4700 output settings are within these tolerance limits.

Preparation

Before attempting any verification ensure that the following steps have been carried out.

1. Before connecting and operating any equipment, consult the manufacturers' handbooks.
2. Ensure that the 4700 and DMM specifications verify at the following voltages:

4700	1V [100mV] RMS; 10V RMS.
DMM	1V [100mV] RMS.
3. Turn on the 4700, DMM and 4600 to be checked and allow at least 2 hours' warm-up in the specified environment.
4. Ensure that the 4700 and 4600 Outputs are **OFF**.
5. The 4600 front panel LEDs should show no errors present. Press the 4700 Test key to carry out the self-test routine on the 4700/4600 combination.

The procedure is detailed on pages 4-A4-6/7.

Slave AC Current Verification Procedure

Record results on Report Sheet 4600 RS 2, (Page 4-A4-RS2-1 & 3)

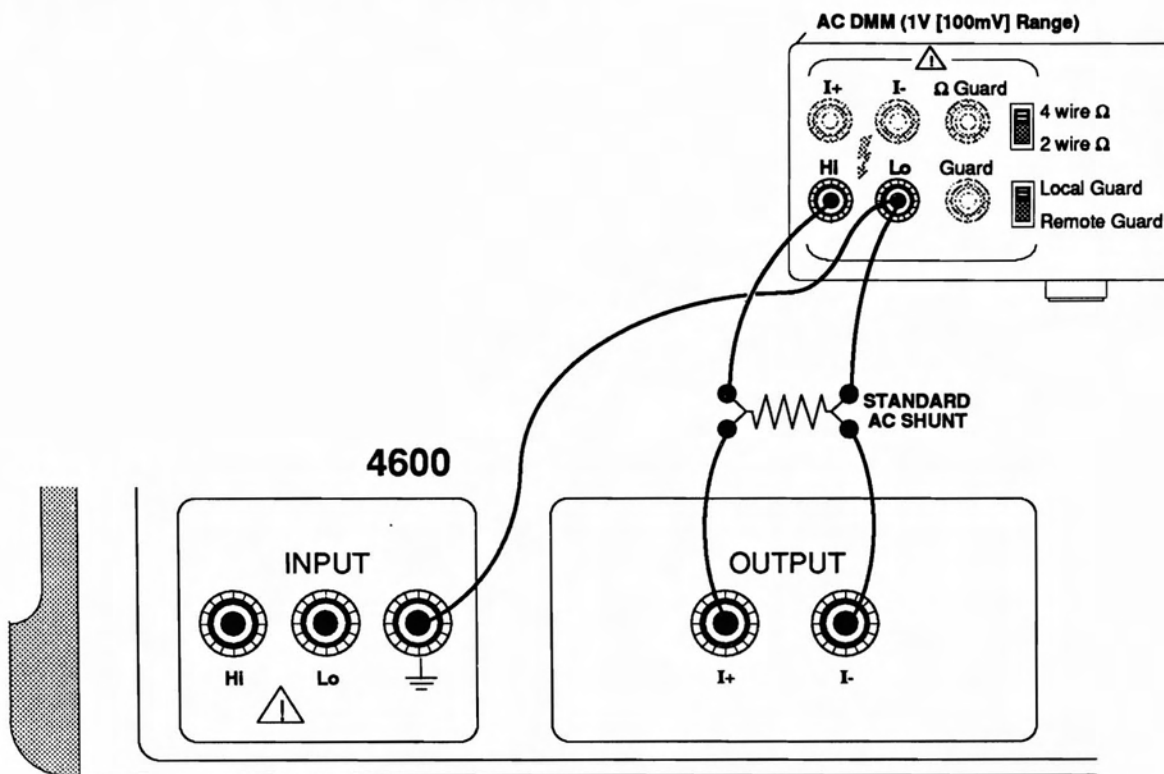

Output Current Measurement

Connect the slaved 4600, Shunt and DMM as shown in the above diagram (ensure the connection of DMM Lo to the 4600 INPUT ground).

Carry out operations (a) to (j):

- | | | | |
|---------|--|---------|---|
| a. 4700 | Ensure that OUTPUT is OFF, FUNCTION to AC then I, FREQUENCY to 300Hz, OUTPUT RANGE to 10, Guard and Sense are controlled by firmware. Press the Full Range key to set the output voltage to 10.00000V RMS. | g. 4700 | Reset FREQUENCY to 20kHz. |
| b. DMM | Set AC range to measure 1V [100mV] RMS. Set Guard to Local. | h. DMM | Record the DMM reading on RS2 Table 2 against 'DMM Transfer Reading' as 'V20k'. |
| c. 4700 | Set OUTPUT ON. | j. 4700 | Set OUTPUT OFF. |
| d. DMM | Record the DMM reading on RS2 Table 2 against 'DMM Transfer Reading' as 'V300'. | | |
| e. 4700 | Reset FREQUENCY to 5kHz. | | |
| f. DMM | Record the DMM reading on RS2 Table 2 against 'DMM Transfer Reading' as 'V5k'. | | |

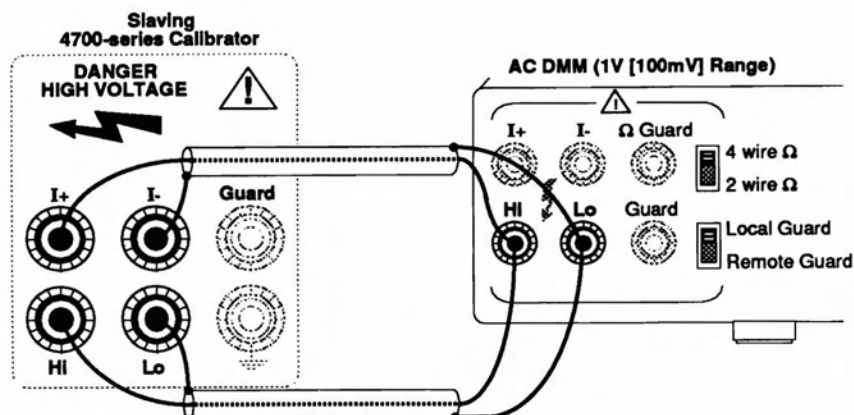

AC - AC Transfer

Connect the DMM to read the 4700 output as in the above diagram. Ensure that the DMM Guard is set to **Local**.

Carry out operations (k) to (q):

- k. 4700 Ensure that OUTPUT is OFF,
FUNCTION to AC, *not* I,
FREQUENCY to 300Hz
OUTPUT RANGE to 1V [100mV],
Sense to Remote.
Guard to Local.
- l. DMM Set AC range to measure 1V [100mV] RMS.
- m. 4700 Set OUTPUT ON.
Adjust the 4700 output voltage to give a DMM
reading of 'V300'.
Record the 4700 output voltage setting against
'Vm' in the 300Hz column of the Report Sheet RS
2 Table 2.
- n. 4700 Set FREQUENCY to 5kHz.
Adjust the 4700 output voltage to give a DMM
reading of 'V5k'.
Record the 4700 output voltage setting against
'Vm' in the 5kHz column of the Report Sheet RS
2 Table 2.
- p. 4700 Set FREQUENCY to 20kHz.
Adjust the 4700 output voltage to give a DMM
reading of 'V20k'.
Record the 4700 output voltage setting against
'Vm' in the 20kHz column of Report Sheet RS 2
Table 2.
Set OUTPUT OFF.

Validity Tolerance Limit Calculations

Refer to Appendix 1 page 4-A4-11 & 12.

- q. Calculate the Lower and Upper Vm Tolerance Limits.
- Use Calculation A if the 4600 was last calibrated by Datron.
 - Use Calculation B if the 4600 was last calibrated against the standards being used for verification.
 - Use Calculation C if the verification immediately follows a calibration using the same equipment.
 - The Slave Full Range AC outputs verify if the value of Vm recorded in (m), (n) and (p) are at or between the corresponding Validity Tolerance Limits.

Validity Tolerance Limit Calculations

This deals with the calculations necessary to determine the Validity Tolerance Limits for each of the verification procedures. Reference to the appropriate calculation is given in each procedure.

Solo Verifications

To confirm the 4600 specification it is necessary to measure its transconductance G_m , whose nominal value is 1 siemens.

$$G_m = I_{out} / V_{in}, \text{ where } V_{out} \text{ is constant.}$$

AC Current

Measurement of G_m

G_m cannot be measured directly; the method described on pages 4-A4-1 to 4-A4-3 employs a precision shunt (value R_s) to convert the output current into a voltage. The shunt voltage is then measured (again indirectly - via a 'transfer' procedure). The method minimizes the effects of the DMM uncertainties.

Procedural Model

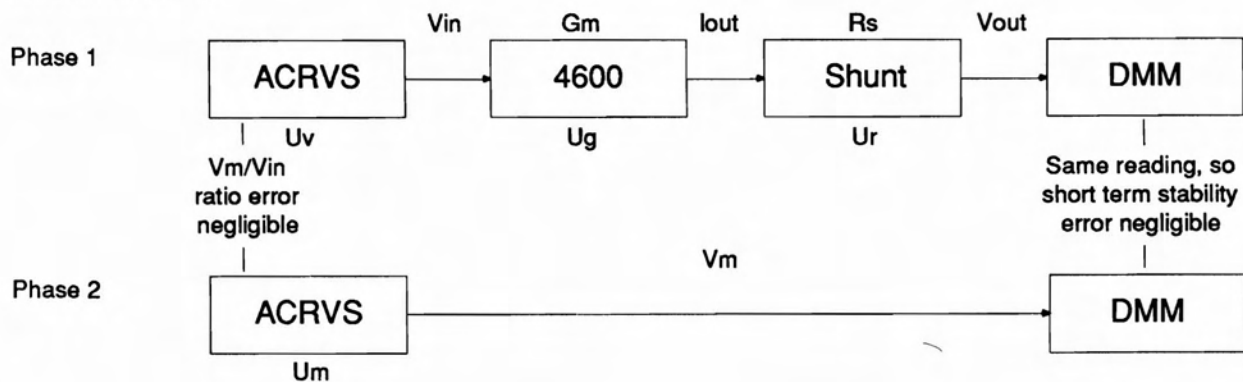

To relate Phase 1 to the value of G_m , the above equation is transposed to place V_{out} as the subject:

$$V_{out} = V_{in} \times G_m \times R_s$$

V_{out} remains constant, as in Phase 2 it is measured by adjusting The ACRVS to obtain the same DMM voltage reading. Thus the basic equation becomes:

$$V_m = V_{in} \times G_m \times R_s$$

Implicit Uncertainties

The uncertainties implicit in the above equation are as follows:

- U_v : Traceable accuracy of the ACRVS 10V output relative to Absolute accuracy.
- U_m : Traceable accuracy of the ACRVS 1V [100mV] output, relative to Absolute accuracy.
- U_r : Traceable AC accuracy of the shunt resistance relative to Absolute accuracy.
- U_g : Traceable AC accuracy of the 4600 relative to Calibration Standards.
- U_x : Short term transfer stability of the DMM.

The calculations to find the Validity Tolerance for this equation for each of the verification points are lengthy and complicated, possibly with unrealistically-large result. But the method itself introduces two major simplifications:

1. By using the DMM only as a transfer standard, adjusting the ACRVS for the same reading during Phase 2, the accuracy required of the DMM is limited to its short-term stability.
2. By using a suitable Datron calibrator as ACRVS (as suggested in 'Equipment Requirements') the ratio error between V_{in} and V_m is very small.

Both these uncertainties are minute compared with other traceable accuracies in the equation. By assuming that they do not exist (in the interests of simplifying the calculations), the Validity Tolerance is made marginally tighter but remains well within the capability of the 4600. The calculation of Validity Tolerance and V_m Limits, detailed overleaf, makes the assumption that the suggested equipment will be used. Note that this may not be valid for other ACRVS/DMM combinations.

Validity Tolerance

The assumptions made on the previous page allow us to discard any uncertainties associated with the DMM transfer error (U_x), the ACRVS 10V output error (U_v) and the ACRVS ratio error (U_m). Thus we need only sum U_r and U_g , plus the uncertainties associated with the most-recent calibration of the 4600; to arrive at the validity tolerance:

Specific Uncertainties

4600 G_m

The allowed uncertainty of G_m consists of its basic accuracy specification relative to calibration standards (U_g), plus the uncertainty to absolute accuracy of its most-recent calibration. It is possible to give both of these if the instrument was last calibrated by Datron, and the values are already entered in the table against U_g and U_d on verification report RS2 for the nominal verification points. For verifications after any calibration other than by Datron, then Datron's calibration uncertainty (U_d) must be replaced by the uncertainty associated the most-recent calibration (U_c). A space is provided in the tables for U_c to be entered. For a verification immediately following a recalibration, using the same equipment in the same conditions, both U_d and U_c can be discarded.

R_s

The uncertainties relative to absolute accuracy associated with the shunt (U_r) will need to be calculated and added to the total for G_m . This forms the total user's uncertainty for the present verification, and a space is provided in the table for it to be entered.

Summing in ppm

The total measurement uncertainty calculation is best carried out all in the same units, and for parts-per-million (ppm) it is a simple sum of the relevant uncertainties. So units such as % should be converted to ppm before summing. A space is provided for entry of the total measurement uncertainty ACUt.

Upper and Lower Limits

Once the validity tolerance in ppm has been calculated for the particular verification being carried out (the interval since the last calibration is significant), the figure is applied to the target value of V_m ($TgtV_m = \text{nominal } I_{out} \times \text{nominal } R_s$), in order to determine the upper and lower voltage tolerances to be placed on the V_m setting for validity of the verification. Spaces are provided in the tables to register these limits.

Measurement Results

A space is provided in the table to enter the actual V_{in} setting, for comparison with the tolerance limits.

Summary of Symbols

The symbols used in the calculations appear in the tables in Verification Report RS2.

Relevant Formulae

The following formulae should be used in the different circumstances shown:

Solo AC Verification at Full Range Values

A. When the Last Calibration was by Datron:

For each 4600 OUTPUT Frequency calculate the Validity Tolerance Limits, using the *90dy* figures for U_g , as follows:

- First enter the user's uncertainty in ppm:

$$U_r$$

(U_g and U_d are already entered for three intervals)

- Next sum the three uncertainties:

$$U_r + U_g + U_d$$

Enter the result on the DC Current table as ACUt.

- Determine the Target Measurement Voltage for each of the three frequencies:

$$TgtV_m = I_{out} \times R_s$$

- Then calculate the Validity Tolerance Limits at each frequency:

$$ULV_m = TgtV_m [1 + (ACUt \times 10^{-6})]$$

$$LLV_m = TgtV_m [1 - (ACUt \times 10^{-6})]$$

Enter the results as Upper and Lower Tolerance Limits for V_m respectively.

B. When the Last Calibration was not by Datron:

Use the calculations in (A), but substitute U_c for U_d .

C. Immediately Following a User-Calibration (Same equipment, same conditions)

Use the calculations in (A), but discard both U_c and U_d , and use the 24hr specification interval figure for U_g .

Validity Tolerance Limit Calculations (Contd)

Slave Verifications

N.B. In this description, reference to a '4700' refers also to a compatible model 4705, 4707 or 4708.

To confirm the 4600 specification it is necessary to measure I_{out} , for a nominal 4700 OUTPUT setting of 10A.

AC Current

Measurement of I_{out}

I_{out} cannot be measured directly, so the method described on pages 4-A4-5 to 4-A4-7 employs a precision shunt (value R_s) to convert the output current into a voltage. The shunt voltage is then measured (again indirectly - via a 'transfer' procedure). The method minimizes the effects of the DMM uncertainties.

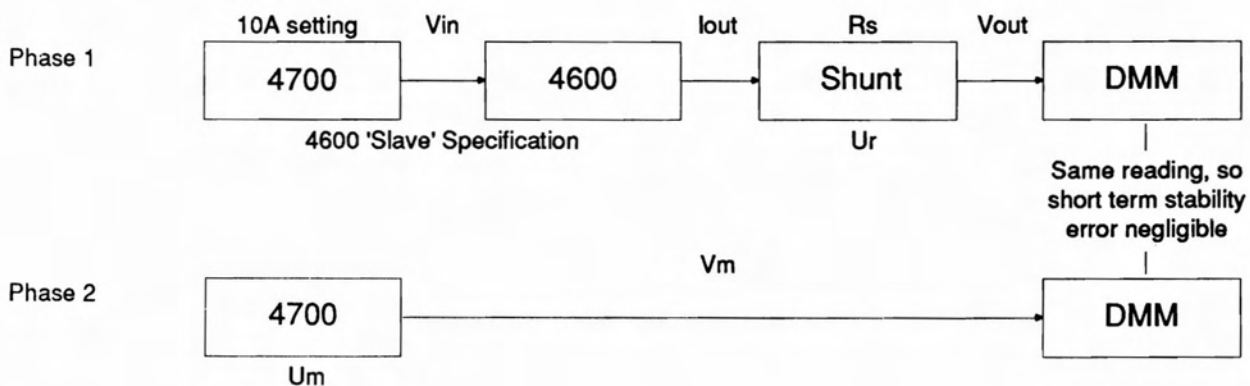

Procedural Model

To relate Phase 1 to the Slave Error, the basic equation places V_{out} as the subject:

$$V_{out} = 10A \times \text{Slave Error} \times R_s$$

V_{out} remains constant, as in Phase 2 it is measured by adjusting the 4700 voltage V_m to obtain the same DMM voltage reading. Thus the basic equation becomes:

$$V_m = 10A \times \text{Slave Error} \times R_s$$

Implicit Uncertainties

The uncertainties implicit in the above equation are as follows:

- Us: Traceable accuracy of the Slaved 10A output relative to Calibration Standards.
- Um: Traceable accuracy of the 4700 1V [100mV] output, relative to Absolute accuracy.
- Ur: Traceable accuracy of the shunt resistance relative to Absolute accuracy.
- Ux: Short term transfer stability of the DMM.

Simplifications

The calculations to find the Validity Tolerance for this equation for each of the verification points are lengthy and complicated, possibly with unrealistically-large result. But the method itself introduces two major simplifications:

1. By using the DMM only as a transfer standard, adjusting the 4700 for the same reading during Phase 2, the accuracy required of the DMM is limited to its short-term stability U_x .

This uncertainty is minute compared with other traceable accuracies in the equation. By assuming that U_x does not exist (in the interests of simplifying the calculations), the Validity Tolerance is made marginally tighter but remains well within the capability of the 4600. The calculation of Validity Tolerance and V_m Limits, detailed overleaf, makes the assumption that the suggested method will be used.

Validity Tolerance

The assumptions made on the previous page allow us to discard any uncertainties associated with the DMM transfer error (U_x). Thus we need only sum U_s , U_m and U_r , plus the uncertainties associated with the most-recent calibration of the 4600 and 4700; to arrive at the validity tolerance:

Specific Uncertainties

4600/4700 Slaved Combination

The allowed uncertainty of the slaved combination consists of the basic accuracy specification relative to calibration standards (U_s), plus the uncertainty to absolute accuracy of the most-recent calibration. It is possible to give both of these if the instrument was last calibrated by Datron, and the values are already entered in the table against U_s and U_d on verification report RS2 for the nominal verification points. For verifications after any calibration other than by Datron, then Datron's calibration uncertainty (U_d) must be replaced by the uncertainty associated the most-recent calibration (U_c). A space is provided in the tables for U_c to be entered. For a verification immediately following a recalibration, using the same equipment in the same conditions, both U_d and U_c can be discarded.

R_s & V_m

The uncertainties relative to absolute accuracy associated with the shunt (U_r) and with the measurement voltage V_m (U_m) will need to be calculated and added to the total for the slaved combination. These two form the total user's uncertainty for the present verification, and spaces are provided in the tables for them to be entered.

Summing in ppm

The total measurement uncertainty calculation is best carried out all in the same units, and for parts-per-million (ppm) it is a simple sum of the relevant uncertainties. So units such as % should be converted to ppm before summing. A space is provided for entry of the total measurement uncertainty $ACUt$.

Upper and Lower Limits

Once the validity tolerance in ppm has been calculated for the particular verification being carried out (the interval since the last calibration is significant), the figure is applied to the target value of V_m ($TgtV_m = \text{nominal } I_{out} \times \text{nominal } R_s$), in order to determine the upper and lower voltage tolerances to be placed on the V_m setting for validity of the verification. Spaces are provided in the tables to register these limits.

Measurement Results

A space is provided in the table to enter the actual V_m setting, for comparison with the tolerance limits.

Summary of Symbols

The symbols used in the calculations appear in the tables in Verification Report RS2.

Slave AC Verification at Full Range Values

A. When the Last Calibration was by Datron:

For each 4600 OUTPUT Value calculate the Validity Tolerance Limits, using the *90dy* figures for U_s , as follows:

- First enter the measurement voltage and shunt uncertainties in ppm:

$$U_m \text{ and } U_r$$

(U_s and U_d are already entered for three intervals)

- Next sum the four uncertainties:

$$U_r + U_s + U_d + U_m$$

Enter the result on the AC Current table as $ACUt$.

- Determine the Target Measurement Voltage for each of the three frequencies:

$$TgtV_m = \text{nominal } I_{out} \times R_s$$

Then calculate the Validity Tolerance Limits for each frequency:

$$ULV_m = TgtV_m [1 + (ACUt \times 10^{-6})]$$

$$LLV_m = TgtV_m [1 - (ACUt \times 10^{-6})]$$

Enter the results as Upper and Lower Tolerance Limits for V_m respectively.

B. When the Last Calibration was not by Datron:

Use the calculations in (A), but substitute U_c for U_d .

C. Immediately Following a User-Calibration (Same equipment, same conditions)

Use the calculations in (A), but discard both U_c and U_d , and use the 24hr specification interval figure for U_s .

Verification Report

4600 RS 2

Model 4600

4600 Serial Number..... Associated 4700/4705/4707/4708 Serial Number.....

Calibration Interval --- 90days---... Specification --- Accuracy ---.....

Date..... Checked by..... Company/Dept.....

Note: On receipt of the instrument it is recommended to check at the values shown in the tables.

The 'Validity Tolerance'

Why is it necessary to calculate this tolerance?

It is impossible to verify the specification of an instrument with absolute certainty, even using the original calibration equipment to make measurements. All measurements carry a degree of uncertainty, this being quantified by the traceability of the measuring equipment.

The measurements attempt to verify that the instrument performs within its specification; ie. it operates within the tolerance of its accumulated uncertainties. But as the measurement itself has its own accumulated uncertainties, these must be added to those of the instrument in order to set a 'Validity Tolerance'.

If an instrument performs within its validity tolerances, all that can be assumed is that its verification is uncertain. For example; if results agree exactly with the instrument settings, the measurements are still

at least as uncertain as the traceability (to absolute accuracy) of the measuring equipment. The only certainty is that if one result exceeds its validity tolerance, then the instrument has failed to verify.

For a verification measurement to be acceptable, therefore, each validity tolerance must express a continuous trace of all the uncertainties from the instrument terminals, via 'Absolute Accuracy', to the measuring equipment connections to those terminals. The validity tolerance of the trace is obtained by adding together all the intervening uncertainties at the time the measurement is made. The specification sets out the worst-case allowances (relative tolerances) for the instrument performance. For the measuring equipment, worst-case tolerances must also be assumed. The full extent of the accumulation is illustrated below in the simplified diagram:

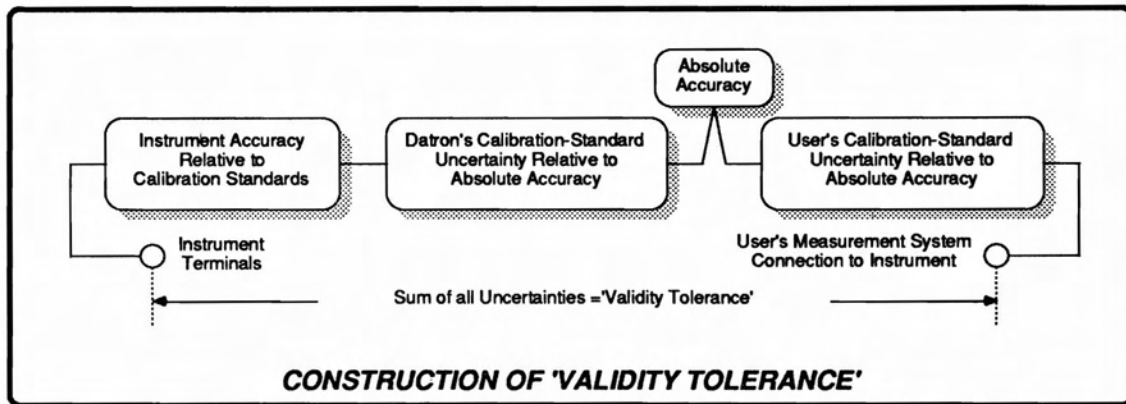

Implementation on Receipt of Instrument

The tables in this report document provide columns to enter both the relevant results of measurements and results of calculations from the measurements. Guidance is given in the form of calculation equations, where to obtain information, and tables to simplify the calculations.

Wherever appropriate and possible, the figures in the columns are already entered (90 day Specification). The recommended methods of setting up the equipment, and measuring the instrument outputs, are described elsewhere in this Appendix.

Implementation after User-calibration

Once the instrument has been calibrated against the user's standards, then Datron's calibration-standard uncertainties can be removed from the validity tolerance calculation.

It is still necessary to include the worst-case user's calibration-standard uncertainties for the time period elapsed since the instrument was last verified or calibrated.

It is anticipated that users will wish to employ their own standard report formats on these occasions.

TABLE 1. SOLO AC CURRENT

Full Range Checks

Calculate Total Measurement Uncertainty
(Enter all uncertainties in ppm)

		4600 Output Measurement Uncertainties (ppm of Full Range) - Verification Frequencies -								
		300Hz			5kHz			20kHz		
Shunt Accuracy relative to Absolute	Ur									
4600 Accuracy relative to Cal. Stds.	Ug	24hr 260	90dy 310	1yr 420	24hr 790	90dy 840	1yr 960	24hr 7320	90dy 8720	1yr 10620
Datron Cal Std uncertainty relative to Absolute	Ud ^[1]	110	110	110	110	110	110	250*	250*	250*
User's Cal Std uncertainty relative to Absolute	Uc ^[2]									
Total Measurement Uncertainty (Validity Tolerance)	ACUt									

Calculate Validity Tolerance Limits

Value of AC Current Shunt	Rs		Ω		Ω		Ω
Target Value for Vm	TgtVm ^[3]		V		V		V
Upper Tolerance Limit for Vm	ULVm		V		V		V
Lower Tolerance Limit for Vm	LLVm		V		V		V

DMM Readings and ACRVS Settings

DMM Transfer Readings		'V300' =	V	'V5k' =	V	'V20k' =	V
Actual ACRVS Settings (Vm) for DMM Transfer Reading	Vm		V		V		V

Notes:

- Use Ud only if the 4600 was last calibrated by Datron.
- Use Uc only if the 4600 was not last calibrated by Datron. Enter the calibration uncertainty for the most-recent calibration.
- The value of TgtVm is dependent on the value Rs of the shunt.

* Estimated

TABLE 2. SLAVE AC CURRENT

Full Range Checks

Calculate Total Measurement Uncertainty
(Enter all uncertainties in ppm)

4600 Output Measurement Uncertainties (±ppm of Full Range)
- Verification Frequencies -
300Hz 5kHz 20kHz

Measurement Voltage Vm accuracy relative to absolute	Um									
Shunt Accuracy relative to Absolute	Ur									
Slaved 4600/4700 AC Accuracy relative to Calibration Standards	Us ⁽⁴⁾	24hr 520	90dy 590	1yr 820	24hr 930	90dy 1000	1yr 1220	24hr 7420	90dy 8960	1yr 10980
Slaved 4600/4705 AC Accuracy relative to Calibration Standards	Us ⁽⁴⁾	24hr 630	90dy 730	1yr 940	24hr 1090	90dy 1190	1yr 1360	24hr 7620	90dy 9320	1yr 11270
Slaved 4600/4707 AC Accuracy relative to Calibration Standards	Us ⁽⁴⁾	24hr 400	90dy 470	1yr 570	24hr 860	90dy 940	1yr 1030	24hr 7320	90dy 8770	1yr 10410
Slaved 4600/4708 AC Accuracy relative to Calibration Standards	Us ⁽⁴⁾	24hr 340	90dy 410	1yr 470	24hr 810	90dy 870	1yr 940	24hr 7320	90dy 8720	1yr 10340
Datron Cal Std uncertainty relative to Absolute	Ud ⁽¹⁾	110	110	110	110	110	110	250*	250*	250*
User's Cal Std uncertainty relative to Absolute	Uc ⁽²⁾									
Total Measurement Uncertainty (Validity Tolerance)	ACUt									

Calculate Validity Tolerance Limits

Value of AC Current Shunt	Rs		Ω		Ω		Ω
Target Value for Vm	TgtVm ⁽³⁾		v		v		v
Upper Tolerance Limit for Vm	ULVm		v		v		v
Lower Tolerance Limit for Vm	LLVm		v		v		v

DMM Readings and 4700 Settings

DMM Transfer Readings		'V300' =	v	'V5k' =	v	'V20k' =	v
Actual 4700 Settings (Vm) for DMM Transfer Reading	Vm		v		v		v

Notes:

1. Use Ud only if the 4600 was last calibrated by Datron.
2. Use Uc only if the 4600 was not last calibrated by Datron.
Enter the calibration uncertainty for the most-recent calibration.
3. The value of TgtVm is dependent on the value Rs of the shunt.
4. Use only one value of Us: the one appropriate to the slaving calibrator in use.

* Estimated

Harmonic Distortion Measurement

Appendix 5 to:
4600 User's Handbook
Section 4

The measurement of True Harmonic Distortion is not detailed as part of the verification procedure. However, some users may wish to check this feature from time to time, so one or two points need to be clarified.

The very low noise content of the 4600 output is included in its accuracy specifications, but not in its TOTAL HARMONIC DISTORTION specifications on page 4-1. The latter relate to true harmonic distortion only.

If the 4600 distortion specification is to be verified, the measurement equipment must be selected with care. Some distortion meters merely suppress the fundamental and measure the remainder over a specific bandwidth. The readings obtained include wideband noise integrated over the full bandwidth, introducing measurement errors which increase the apparent harmonic distortion (particularly at low fundamental levels, where the harmonic envelope rapidly descends into the noise floor).

Measurement of true harmonic distortion only, in any signal, can be a laborious process. To measure the value of each single frequency harmonic, (as would be required to verify the 4600 THD specification), any wideband noise must be filtered out. Very selective bandpass notch filtering is required; this is usually achieved by phase-locking the measurement circuitry to the signal, as performed by a selective signal level meter.

A modern automatic spectrum analyser is more satisfactory. The harmonic amplitudes can be displayed on a screen against a grid, the noise levels can also be seen, or a cursor can be used to set a bandpass notch filter to the harmonic frequency required, to give a direct digital readout. THD measurement is simplified and speeded up by this method.

It is therefore recommended that either a spectrum analyser or selective level meter be employed. Suitable instruments are:

Hewlett-Packard HP3585 Spectrum Analyser,
or HP3586 Selective Level Meter.

)

)

)

)

)

)

)

)

)

)

)

)

)

)

)

)

)

)

)

)

)

)

SECTION 5 4600 Calibration

Routine Calibration

Reasons for Recalibration

Scheduled Recalibration

Calibration Modes

The 4600 has two separate modes of operation: Solo and Slave modes. Each mode is calibrated independently of the other by different methods, there being no mutual interaction.

Routine calibration in Solo mode consists of adjusting two internal trim potentiometers and an adjustable trimmer capacitor, which are connected into the circuit only in Solo mode.

Routine calibration in Slave mode is carried out from the front panel of the slaving 4700-series calibrator. This process corrects the reference voltage by which the 4700 controls the 4600 output, but makes no physical adjustment to the 4600 itself. Although the reference voltage is derived from the 4700's 10V range circuitry, routine recalibration of the 10V range does not affect the 4600 calibration (and vice versa), as the 10V range and reference voltage have separate calibration corrections, each held in separate non-volatile memory stores.

In effect, the slaved combination behaves as if the 10A range provided by the 4600 were merely another range built in to the 4700. All the built-in 4700 facilities such as Error and Offset modes (and the SET and STD calibrations), are available for the 10A range.

Calibration of Slave Mode on Receipt (Special Case)

The 4600 is fully calibrated in Solo and Slave modes before leaving the factory, but from the previous description it can be seen that the Slave mode corrections are held in the non-volatile memory of the 4700-series instrument with which it was calibrated. If both calibrator and 4600 were supplied as a combination, the 4600 factory calibration is still valid. But if the 4600 was supplied on its own (possibly for use with an existing compatible 4700-series calibrator, or for use in Solo mode with existing voltage reference sources), then it will be necessary to repeat the Slave mode calibration in combination with any compatible 4700-series calibrator to which it is to be slaved.

Calibration Intervals

The specifications for the 4600 are based on standard intervals of up to 24 hours, 90 days or 1 year from calibration. Some users will wish to maintain the highest accuracy by recalibrating at short intervals (e.g. every 24 hours). In these cases, recalibration becomes a routine task.

Users may wish to choose alternative schemes, accounting for:

- The accuracy required when in use,
- The instrument specifications (this handbook Section 4),
- The scheduled calibration intervals normally adopted by the user's organization

Restandardization (Slave mode)

Occasions may arise when it is necessary to trim the slaving 4700's internal Master Reference. For example, when the combination is to be made traceable to a different National Standard, after transportation from one country to another (*Refer to AUTOCAL FACILITIES, page 1-3 of the Calibration and Servicing Handbook for the relevant 4700-series calibrator*). Carried out on the 10V or 1V DC range, this process corrects all Voltage and Current ranges, including the 4600 10A range output.

Pre-calibration Procedures (Slave mode)

In an initial internal calibration process at manufacture of the 4700-series calibrator, certain 'Pre-cal' parameters are established in a special calibration memory.

Under certain conditions (*detailed in Table 1.1 of the Calibration and Servicing Handbook for the relevant 4700-series calibrator*) these parameters need to be re-established by completing the 'Pre-Cal' procedure before a Full Routine Autocalibration. Subsequent to this Pre-Cal, the 4600 Routine Calibration will also be required.

Calibration Memory Corruption (Slave Mode)

Battery Change

Calibration corrections for a slaved 4600 are stored by the slaving 4700 in an internal memory which remains energized by a battery. The Lithium battery which powers the non-volatile calibration memory should be replaced after 5 years (*Refer to Section 4.3 of the Calibration and Servicing Handbook for the relevant 4700-series calibrator*). After replacement, a full Pre-calibration is required followed by a complete Routine Autocalibration (this includes the 4700/4600 10A range).

Memory Check failure

When the slaving 4700 Cal key is pressed to effect the 4600 calibration, the correction constant is checked to be within prescribed limits before being stored. Values outside prescribed limits flag a *Fail 6*. On the following occasions, the same check is performed and *Fail 6* can indicate a corruption in the slaved 4600's correction memory:

- When the 4700 is powered-up,
- When the 4700 10A range is selected,
- Each time the output is switched ON,
- During each self-test routine.

Critical Part Changes

Recalibration (or Verification) is necessary after replacement of a critical PCB assembly or a critical component. These are listed in Section 8, Table 8.1, indicating the extent of the recalibration necessary.

Recalibration Procedures in this Section

Routine Calibration (Solo mode)

Routine Autocalibration (Slave mode)

These Routine Calibration procedures are sufficient for all normal recalibration purposes, except when Common mode, DC Offset or Autobias correction is called for (*refer to Table 8.1*).

Remote Calibration

via the IEEE 488 Interface (Slave mode)

The 4600 has no IEEE 488 interface of its own, so remote control in Solo mode is unavailable.

The device-dependent commands necessary for routine calibration of the slaved 4600 via the IEEE 488 bus are given in Section 3, page 3-12. A guide-line example is given in Section 1 of the relevant Calibration and Servicing Handbook for the slaving 4700 (Vol 1), but this needs to be adapted for the bus controller in use.

Calibration Sequence Profiles

The methods and sequence of calibration depend on how the 4600 is intended to be used, and whether it is to be slaved to a 4700-series calibrator. This leads to two ways of setting about the calibration.

1. Solo Only

If the 4600 is not to be slaved to any 4700-series calibrator, then it will not be possible to calibrate its slaved operation. In this case, proceed as follows:

- a. Verify the Voltage Source to be used as reference for the 4600;
- b. Calibrate the 4600 in Solo mode.

2. Slaved to a 4700-series Calibrator

Use the following sequence:

- a. Ensure that the specification of the 4700-series calibrator is verified;
- b. Use that calibrator to calibrate the 4600 in Solo mode;
- c. Slave the 4600 to that same calibrator, and use the calibrator front panel keys to calibrate the slaved combination.

Option Requirements for Slave Mode

Slave Mode needs issue 5 firmware or later.

4700 needs option 20 for current outputs.

4707 needs option 27 for current outputs.

4708 needs options 10 and 30 for DC current outputs,
or 20 and 30 for AC Current outputs.

Evaluating User's Calibration Uncertainties

Naturally, the performance of any equipment is affected by the range, accuracy and traceability of the users' standards against which it is calibrated.

Where traceability is of importance, users will need to evaluate the effects of their own Standards' uncertainties on the performance of equipment such as the 4600.

Section 4 and its appendices contain descriptions and calculations which are necessary to establish a 'Validity Tolerance' for the results of verification procedures. The calibration processes in this section can be a means of reducing the magnitude of uncertainties which go to make up the Validity Tolerance, and so the calculations in Section 4 appendices can assist in evaluating these uncertainties.

Preparing the 4600 for Calibration

General

Before any calibration is carried out, prepare the 4600 as follows:

Turn on and allow a minimum of 2 hours to warm up in the specified environment.

Solo Mode

If the 4600 is to be calibrated in **Solo** mode:

Using the 2.5mm hexagon key from the tool kit, loosen and remove the four M4 countersunk screws retaining the 4600 top cover, but to avoid internal cooling do not lift the cover until required by the Solo calibration procedure.

Slave Mode

If the 4600 is to be calibrated in **Slave** mode, prepare the slaving 4700-series calibrator as follows:

1. Turn on and allow a minimum of 2 hours to warm up in the specified environment.
2. Cancel any MODE keys, ensure OUTPUT set to **OFF**.
3. IEEE 488 Address switch:
Set to ADD 11111 (Address 31) unless the 4700 is to be calibrated via the IEEE 488 interface.
4. CALIBRATION ENABLE key switch:
Insert Calibration Key and turn to **ENABLE**.

These actions activate the four calibration modes (labelled in red), and present the **cal** legend on the MODE display.

Caution

Inadvertent use of the Cal key will overwrite the calibration memory!

For other **warning** and **cautionary** notices, and more details of the calibration facilities of the slaving 4700-series calibrator, refer to Section 1 of its Calibration and Servicing Handbook.

Returning the Solo 4600 to Use

When any Solo mode calibration is completed, return the 4600 to use as follows:

1. Ensure that the OUTPUT OFF LED is lit.
2. Refit and tighten the four M4 screws to retain the top cover.

Returning the Slaved 4600 to Use

When any Slave mode calibration is completed, return the slaved 4700/4600 combination to use as follows:

1. Ensure that both OUTPUT **OFF** LEDs are lit.
2. 4700 CALIBRATION ENABLE key switch:
Turn to **RUN** and withdraw calibration key.
3. IEEE 488 Address switch:
Restore to the **correct address** if the 4700 is to be used in an IEEE 488 system. If not, set any address other than 31 to prevent inadvertent entry to Cal mode.

The **cal** legend and calibration modes are deactivated.

4600 Solo Calibration

General Philosophy

Correction of Transconductance

To calibrate a 4600 in Solo mode, we correct its transconductance value, by providing a traceable DC or AC voltage input and correcting the current output.

DC Outputs

For DC output the calibration method relies on the accuracy provided by the measurement of voltage across a precision 10A shunt, using a high-quality (ie stable) DMM, used only as a transfer-measurement device to remove its inherent uncertainties.

The DMM is first standardized to the same traceable voltage source used as input to the 4600, at the expected voltage due to the value of the selected shunt. The calibration points are: 0V and +10V of input voltage, producing 0A and +10A respectively. The source of DC voltage is referred to in the procedure as the 'DCRVS' (DC Reference Voltage Source).

AC Outputs

To correct the AC output, a DC/AC thermal transfer can be used with a 10A shunt. The DC output of the same 4600 can be used as the reference DC current source for the transfer, its DC specification being sufficiently accurate. The AC calibration should be carried out immediately after the DC calibration of the 4600, to take advantage of readings already taken. The calibration points are: 10V RMS of input voltage at 300Hz and 5kHz in turn, producing 10A RMS at the same frequencies. To generate the reference DC current, the DCRVS is used as input to the 4600; the source of AC voltage for correction of the output is referred to in the procedure as the 'ACRVS' (AC Reference Voltage Source).

Shunt Values

In the following procedures, the shunt voltage values are given for a 100mΩ shunt; values for a 10mΩ shunt are indicated by square braces [...].

Sequence Profile

Before embarking on any calibration, decide which sequence profile is to be followed, after reading the paragraphs headed 'Calibration Sequence Profiles' on page 5-2. The following procedures should form only part of that profile.

Interconnections

Interconnection instructions in this section are necessarily simple and basic, and are mainly intended to show connections to the 4600. It is recognized that they may need to be adapted to meet an individual user's requirements.

Operation of Standards Equipment

It is assumed that users will possess adequate knowledge of the operation and use of the required standards equipment.

Alternative AC Current Calibration

An alternative method of calibrating AC current output, using a DMM for AC-AC transfer, can be found in Appendix 1 to this section.

Location of Internal Controls

The internal trim pots and trimming capacitors, used to correct the 4600 output, are at the left front of of the Sense Assembly (shown in Fig. 5.1 below).

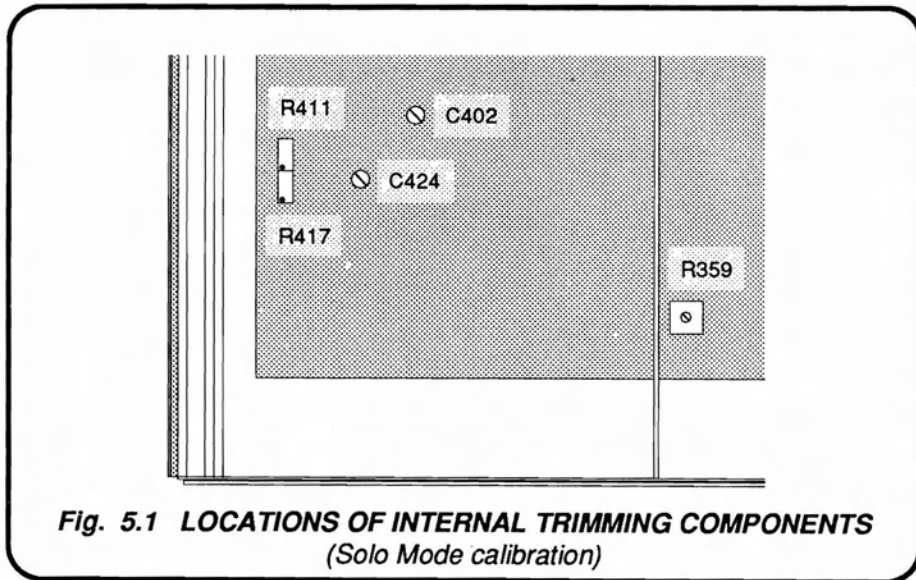

Fig. 5.1 LOCATIONS OF INTERNAL TRIMMING COMPONENTS
(Solo Mode calibration)

Solo DC Current Calibration

Zero and Full Range

The Solo 4600 is calibrated by correcting its transconductance. The DCRVS inputs a voltage, and the output current value is corrected by internal adjustment. A shunt converts the output current to a voltage, measured across the shunt using a DMM which we have first 'Standardized' to the DCRVS.

'Standardizing' ensures that the DMM is aligned to the DCRVS, at the expected values of shunt voltage. 10A will produce 1V across a 100mΩ shunt [100mV for a 10mΩ shunt]. A table given in the procedure relates the DCRVS settings used to standardize the DMM to the expected voltages, for each shunt value.

Equipment Requirements

- A DC Reference Voltage Source (DCRVS), calibrated to suitable accuracy at Zero, $\pm 10V$ and $\pm 1V$ [$\pm 100mV$].
Example: A Datron 4000/A, 4700 or 4708.
- A Calibrated 10A Current Shunt of suitable accuracy, of value 100mΩ [10mΩ].
- A DMM of sufficient resolution and stability, for use as a transfer device to measure the DC voltage across the shunt.
Example: A Datron 1281, 1081 or 1071.

CAUTION

When choosing a 10A current shunt, ensure that its rated power dissipation is sufficient to avoid permanent degradation from the self-heating effects of the current being checked.

Summary of DC Procedure

General

The 4600 is calibrated at two output currents: 0A and +10A, corresponding to input voltages of 0V and +10V. The outputs pass through a precision current shunt of value 100mΩ [or 10mΩ]; the resulting voltages of 0V and +1V [0V and +100mV] are measured by a previously-standardized DMM. The 4600 output is corrected at these two values.

DMM Standardization

The specification of the DC Reference Voltage Source (DCRVS) should be known to verify at the voltages to be used. It is then used to standardize the DMM, at the voltages it will be measuring.

4600 DC Current Calibration

The DCRVS output is then applied to the Solo 4600 INPUT terminals. The OUTPUT I+ and I- terminals of the 4600 are connected to pass the output current through the shunt, and the DMM is connected to measure the voltage across the shunt.

The 4600 input voltage is set to nominal 0V, and the shunt voltage is measured. The 4600 internal 'Offset' trimpot is adjusted for a standardized reading on the DMM. With an input voltage of +10V, the 4600 internal 'Gain' trimpot is adjusted for a second standardized reading on the DMM.

The 4600 should then be verified at 0A, +10A and -10A in accordance with the procedure on pages 4-5 to 4-7 of Section 4.

Preparation

Before attempting any calibration ensure that the following steps have been carried out.

1. Before connecting and operating any equipment, consult the manufacturers' handbooks.
2. Ensure that the DCRVS and DMM specifications verify at the following voltages:
DCRVS 0V; +1V [100mV]; +10V.
DMM 0V; +1V [+100mV].
3. Comply with the instructions for 'Preparing the 4600 for Calibration' on page 5-3.
4. The 4600 front panel LEDs should show no errors present. Carry out any self-test routine on the DCRVS.

The procedure is detailed on pages 5-6/7.

Solo DC Current Calibration Procedure

First Standardize the DMM at 1V [100mV]

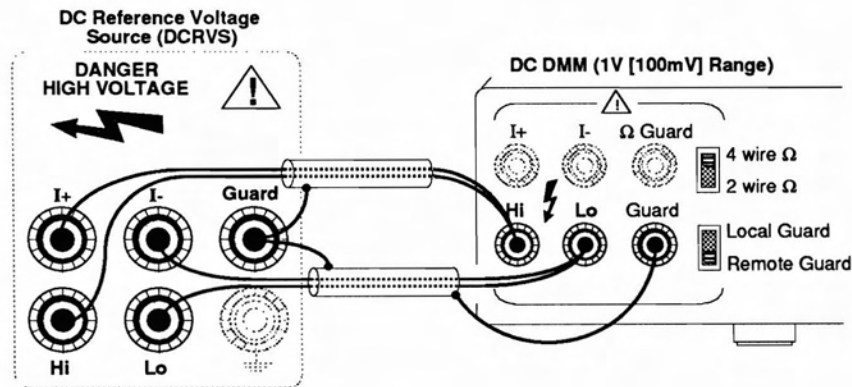

Connect the DMM to read the DCRVS output as in the above diagram. Ensure that the DMM Guard is set to **Remote**.

Carry out operations (a) to (e) at +Full Range:

- a. **DCRVS** Ensure that OUTPUT is OFF, FUNCTION to DC Voltage, OUTPUT RANGE to 1V [100mV], Sense to Remote. Guard to Local. OUTPUT voltage to the appropriate value shown in the Table.
- b. **DMM** Ensure that the DMM has been 'Input Zeroed'. Set DC range to measure the selected DCRVS output voltage (see Table).
- c. **DCRVS** Set OUTPUT ON.
- d. **DMM** Note the reading as '+V1' (See Table).
- e. **DCRVS** Set OUTPUT OFF.

Standardization points:

Point	DCRVS Setting		Note DMM reading as
	100mΩ Shunt	10mΩ Shunt	
+Full Range	+1.000000V	+100.0000mV	'+V1'

Correct the 4600 DC Output

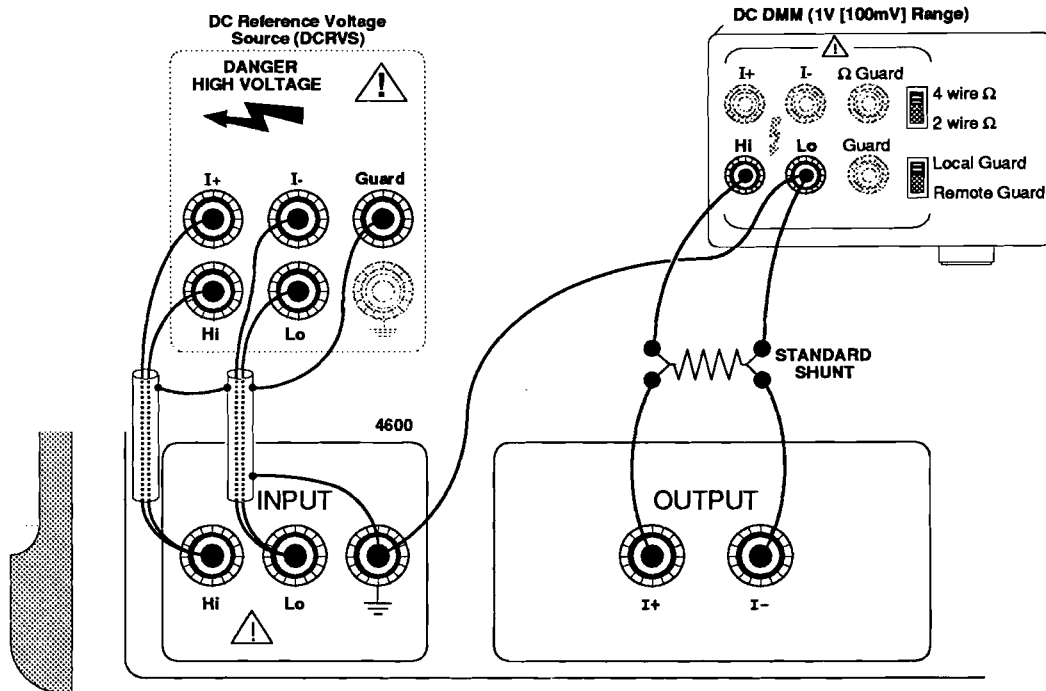

Connect the DCRVS, 4600, Shunt and DMM as shown in the above diagram (ensure the connection of DMM Lo to the 4600 INPUT ground).

Carry out operations (f) to (j).

- f. DCRVS
 - i. Set FUNCTION to DC Voltage.
 - ii. Select the 10V range, Sense and Guard to Remote.
 - iii. Set Output to 0.00000V.
 - iv. Set Output ON.
- g. 4600
 - i. Set Output ON.
 - ii. Lift the top cover and locate R411 (DC Offset trimpot).
 - iii. Adjust R411 to obtain a DMM reading of 0.00000V.
 - iv. Refit the top cover (do not secure).
 - v. Check that the DMM reading is 0.00000V
- h. DCRVS
 - i. Set FUNCTION to DC Voltage.
 - ii. Select the 10V range, Remote Guard.
 - iii. Set Output to +10.00000V.
 - iv. Set Output ON.

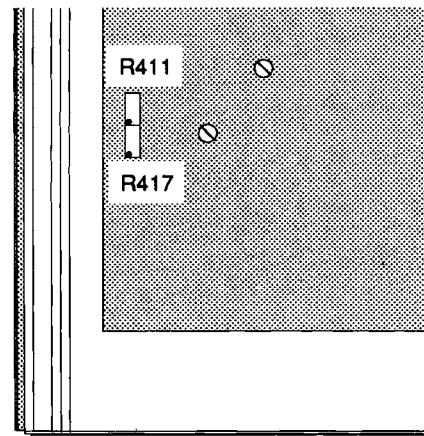

- j. 4600
 - i. Set Output ON.
 - ii. Lift the top cover and locate R417 (Gain trimpot).
 - iii. Adjust R417 to obtain a DMM reading of '+V1' noted in (d).
 - iv. Refit the top cover (do not secure).
 - v. Check that the DMM reading is '+V1'.

Verify the DC specification as in Section 4, pages 4-5 to 4-7.

Solo AC Current Calibration

Full Range

The Solo 4600 is calibrated by correcting its transconductance. A Thermal Transfer Standard (TTS), in conjunction with a 10A shunt, is first nulled at the verified DC current output from the 4600; using the DCRVS to provide the 4600 input reference voltage.

We then use the ACRVS to input 5kHz AC voltage to the 4600, adjusting an internal trimmer capacitor to obtain a null on the TTS.

Equipment Requirements

- The DC Reference Voltage Source (DCRVS) used in the previous procedure to verify the 4600 DC current output.
Example: A Datron 4000/A, 4700 or 4708.
- An AC Reference Voltage Source (ACRVS) of suitable accuracy, with its specification verified for 10V RMS outputs at 5kHz.
Example: A Datron 4200A, 4700 or 4708.
- A Calibrated AC 10A Thermal Transfer Current Shunt of suitable accuracy, of value 100m Ω [10m Ω].
Example: Holt HCS 1.
- A Thermal Transfer Standard of sufficient resolution and stability, for use in conjunction with the shunt.

CAUTION

When choosing a 10A current shunt, ensure that its rated power dissipation is sufficient to avoid permanent degradation from the self-heating effects of the current being checked.

Summary of AC Procedure

General

The 4600 DC output is used as reference current. The 4600 is corrected at 5kHz; for an input voltage of 10V RMS. The AC output is measured using a thermal transfer standard with a precision current shunt of value 100m Ω [or 10m Ω].

TTS Null to DC Reference Current

The OUTPUT I+ and I- terminals of the 4600 are connected to pass the output current to a thermal transfer standard, used in conjunction with a 10A current shunt. The TTS is nulled for a DC reference current, derived by driving the 4600 from the DCRVS set to the voltage previously recorded for 10A DC output.

4600 AC Current Calibration

The 4600 input voltage is set to nominal 10V at 5kHz. The 4600 internal 'HF Gain Compensation' trimmer capacitor C424 is adjusted for the 4600 output current to give a null on the TTS.

Preparation

N.B. The following gives the full preparation assuming that DC Cal. has not been carried out. For best results the DC Cal. should immediately precede AC Cal., so some of the items will be unnecessary.

Before attempting any verification ensure that the following steps have been carried out.

1. Before connecting and operating any equipment, consult the manufacturers' handbooks.
2. Check that the ACRVS specification is verified for 10V output at 5kHz.
3. Check that the Solo 4600 specification is verified for +10A DC output.
3. Comply with the instructions for 'Preparing the 4600 for Calibration' on page 5-3.
4. The 4600 front panel LEDs should show no errors present. Carry out any self-test routines on the DCRVS and ACRVS.

The procedure is detailed on pages 5-10/11.

Solo AC Current Calibration Procedure

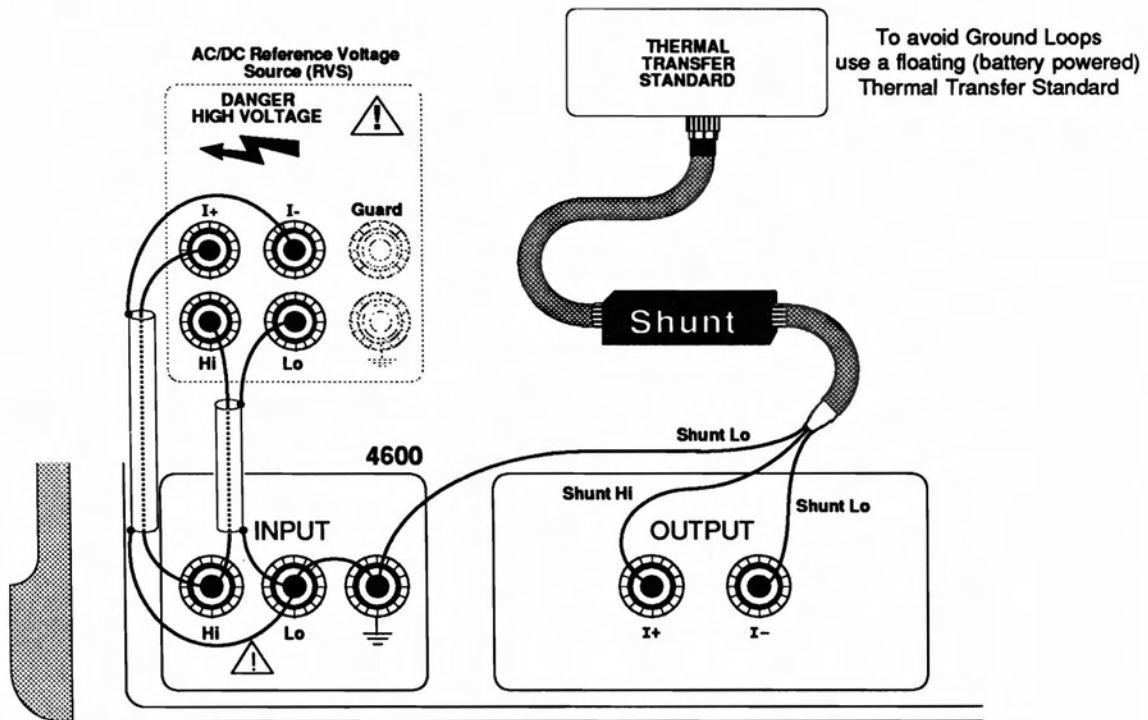

First Null the TTS at 10A DC

Connect the DCRVS output to the 4600 INPUT terminals as in the diagram. Connect the shunt and TTS to the 4600 OUTPUT terminals as shown (ensure the connection of Shunt Lo to the 4600 INPUT ground).

Carry out operations (a) to (g):

- | | |
|---|--|
| <p>a. DCRVS Ensure that OUTPUT is OFF, FUNCTION to DC Voltage, OUTPUT RANGE to 10V, Sense to Remote, Guard to Local, OUTPUT voltage to 10.00000V DC.</p> | <p>e. TTS Adjust for a Null reading. Allow the reading to stabilize. Readjust for a Null reading.</p> |
| <p>b. TTS Set range to maximum.</p> | <p>f. 4600 Set OUTPUT OFF.</p> |
| <p>c. DCRVS Set OUTPUT ON.</p> | <p>g. DCRVS Set OUTPUT OFF and disconnect from the 4600 INPUT terminals.</p> |
| <p>d. 4600 Set OUTPUT ON. Check that the OUTPUT ON key LED lights and the TTS indicates. Set OUTPUT OFF. Check that the OUTPUT OFF key LED lights and the TTS indication falls to null. Reset OUTPUT ON.</p> | |

Correct the 4600 AC Output

Connect the ACRVS output to the 4600 INPUT terminals.

Carry out operations (h) to (p):

- h. **ACRVS** Ensure that **OUTPUT** is **OFF**,
FUNCTION to **AC Voltage**,
FREQUENCY to **5kHz**,
OUTPUT RANGE to **10V**,
Sense to **Remote**,
Guard to **Local**,
OUTPUT voltage to **10.00000V RMS**.
- j. **TTS** Set range to maximum.
- k. **ACRVS** Set **OUTPUT ON**.
- l. **4600** Lift the top cover and locate **C424** (ACHF gain compensation trimming capacitor).
Set **OUTPUT ON**. Note that the **TTS** indicates.
Adjust **C424** for a **Null** reading on the **TTS**,
increasing **TTS** sensitivity to obtain the best null.
Allow the reading to stabilize.
Readjust **C424** for a **Null** reading on the **TTS**.
Refit and secure the top cover.
- p. **ACRVS** Set **OUTPUT OFF**.

Verify the 4600 specification as detailed in Section 4, pages 4-9 to 4-11 (the **TTS** is already standardized).

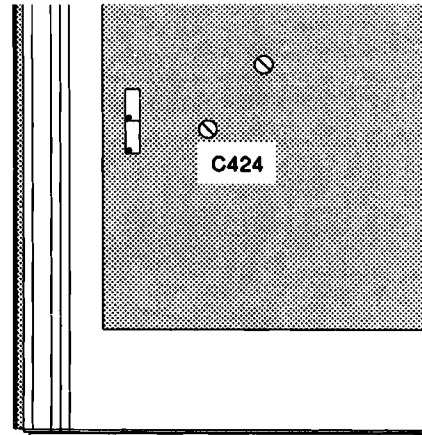

4600 Slave Calibration

N.B. In this sub-section, reference to a '4700' refers also to a compatible model 4705, 4707 or 4708.

General Philosophy

Correction of Output

To calibrate a 4600 which is slaved to a particular 4700-series calibrator, we measure its output current (using the same techniques as for Solo mode), which is then corrected to agree with the slaving 4700's OUTPUT setting.

DC Outputs

For DC output the method of correction relies on the accuracy provided by the measurement of voltage across a precision 10A shunt, using a high-quality (ie stable) DMM, but only as a transfer-measurement device to remove its inherent uncertainties. It is first standardized to the voltage output of the slaving 4700, at the expected voltage due to the value of the selected shunt. The combination is then corrected at: 0A and +10A.

AC Outputs

To calibrate the AC output, an AC/DC thermal transfer can be used with a 10A shunt. The DC output of the same slaved 4600 can be used as the reference DC current source for the transfer, its DC specification being sufficiently accurate. The AC calibration should be carried out immediately after the DC calibration to take advantage of readings already taken. The combination is corrected for 10A RMS of output current at 5kHz. To generate the reference DC current, the combination first operates in its DC function; then correction in AC function is carried out.

Shunt Values

In the following procedures, the shunt voltage values are given for a 100m Ω shunt; values for a 10m Ω shunt are indicated by square braces [...].

Sequence Profile

Before embarking on any calibration, decide which sequence profile is to be followed, after reading the paragraphs headed 'Calibration Sequence Profiles' on page 5-2. The following procedures should form only part of that profile.

Interconnections

Interconnection instructions in this section are necessarily simple and basic, and are mainly intended to show connections to the 4600. It is recognized that they may need to be adapted to meet an individual user's requirements.

Operation of Standards Equipment

It is assumed that users will possess adequate knowledge of the operation and use of the required standards equipment.

Slave DC Current Autocalibration

Zero and Full Range

The 4700/4600 combination is calibrated by correcting its output. We use the 4700 Cal mode to adjust the output current value so that it agrees with the 4700 OUTPUT setting. A shunt converts the output current to a voltage, measured across the shunt using a DMM which we have first 'Standardized' to the 4700 voltage.

'Standardizing' ensures that the DMM is aligned to the 4700 at the expected values of shunt voltage. 10A will produce 1V across a 100mΩ shunt [100mV across a 10mΩ shunt]. A table given in the procedure relates the 4700 settings used to standardize the DMM to the expected voltages, for each shunt value.

Equipment Requirements

- The slaving 4700, DC voltage verified to suitable accuracy at Zero, +10V and +1V [+100mV].
- A Calibrated 10A Current Shunt of suitable accuracy, of value 100mΩ [10mΩ].
- A DMM of sufficient resolution and stability, for use as a transfer device to measure the DC voltage across the shunt.
Example: A Datron 1281, 1081 or 1071.

CAUTION

When choosing a 10A current shunt, ensure that its rated power dissipation is sufficient to avoid permanent degradation from the self-heating effects of the current being checked.

Summary of DC Procedure

General

The 4600 is calibrated at two output currents: 0A and +10A. The outputs are passed through a precision current shunt of value 100mΩ [or 10mΩ], the resulting voltages of 0V and +1V [0V and +100mV] being measured via a previously-standardized DMM. The 4600 output is corrected at these two values, and then verified in accordance with Section 4.

DMM Standardization

The specification of the 4700 should be known to verify at the voltages to be used. It is then used to standardize the DMM, at the voltages it will be measuring.

Slave DC Current Calibration

The 4600 is connected in Slave mode to the 4700. The 4600 OUTPUT I+ and I- terminals are connected to pass the output current through the shunt, and the DMM is connected to measure the voltage across the shunt.

The 4700 10A DC OUTPUT RANGE is selected. With its OUTPUT display set to nominal 0A, the shunt voltage is measured. The 4700 Cal mode is used to calibrate Zero for a standardized reading on the DMM. With the 4700 output set to nominal +10A, the 4700 Cal mode is used to calibrate Full Range at a second standardized reading on the DMM.

The 4600 should then be verified at 0A and ±10A in accordance with the procedure on pages 4-14 to 4-15 of Section 4.

Preparation

Before attempting any calibration ensure that the following steps have been carried out.

1. Before connecting and operating any equipment, consult the manufacturers' handbooks.
2. Ensure that the 4700 and DMM specifications verify at the following voltages:

4700	0V; +1V [100mV]; +10V.
DMM	0V; +1V [+100mV].
3. Comply with the instructions for 'Preparing the 4600 for Calibration' on page 5-3.
4. The 4600 front panel LEDs should show no errors present. Press the 4700 Test key to carry out the self-test routine on the 4700/4600 combination.

The procedure is detailed on pages 5-14/15.

Slave DC Current Calibration Procedure

First Standardize the DMM at 1V [100mV]

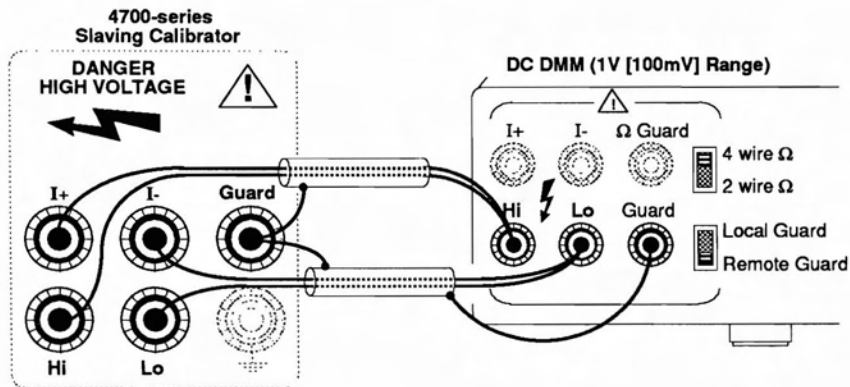

Connect the DMM to read the 4700 DC voltage output as in the above diagram. Ensure that the DMM Guard is set to **Remote**.

Carry out operations (a) to (e) at each of the two points in the table (Zero and +Full Range) in turn:

- 4700** Ensure that OUTPUT is OFF, FUNCTION to DC, OUTPUT RANGE to 1 [100m], Sense to **Remote**, Guard to **Local**, OUTPUT voltage to the appropriate value shown in the Table.
- DMM** Set DC range to measure the selected 4700 output voltage (see Table).
- 4700** Set OUTPUT ON (use ON+)
- DMM** Note the reading as 'V0' or '+V1' (See Table).
- 4700** Set OUTPUT OFF.

Standardization point:

Point	4700 Setting		Note DMM reading as
	100mΩ Shunt	10mΩ Shunt	
Zero	.000000V	.0000V	'V0'
+Full Range	+1.000000V	+100.0000mV	'+V1'

Correct the 4600 DC Output

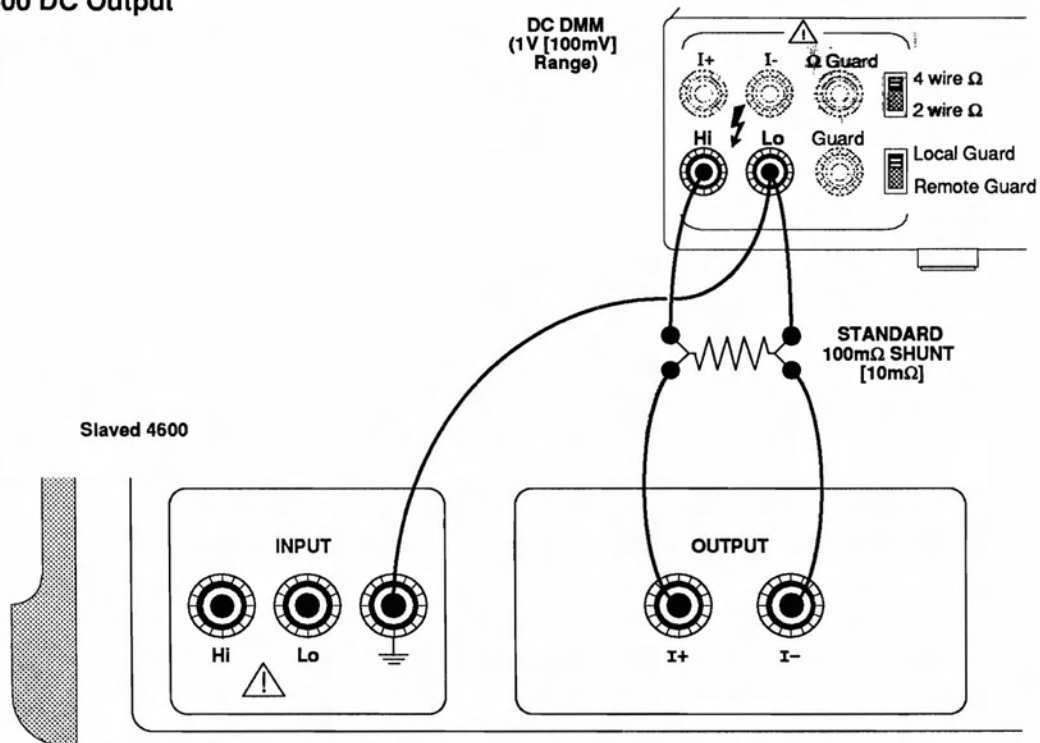

Connect the 4700 and 4600 in Slave mode. Connect the 4600, Shunt and DMM as shown in the above diagram (ensure the connection of DMM Lo to the 4600 INPUT ground).

Carry out operations (f) to (k).

f. 4700
(Zero)

- i. Set FUNCTION to DC, then I.
- ii. Select RANGE 10, Guard, and Sense are controlled internally by firmware.
- iii. Set Output to 0.00000A by pressing the 'Zero' key.
- iv. Press the ON+ key. Check that the 4700 and 4600 ON key LEDs light and the DMM indicates.
- v. Set OUTPUT OFF. Check that the 4700 and 4600 ON key LEDs go out, OFF LEDs light and the DMM indication falls to zero.

g. 4600

- i. Press the OUTPUT ON+ key. Check that the 4700 and 4600 ON key LEDs light and the DMM indicates.
- ii. Set OUTPUT OFF. Check that the 4700 and 4600 ON key LEDs go out, OFF LEDs light and the DMM indication falls to zero.

h. 4700

- i. Press the OUTPUT ON+ key.
- ii. Adjust OUTPUT $\uparrow \downarrow$ keys to obtain a DMM reading of 'V0' recorded in (d).
- iii. Correct by pressing the Cal key.

j. 4700
(+Full Range)

- i. Set Output to +10.00000A by pressing the 'Full Range' key.
- ii. Adjust OUTPUT $\uparrow \downarrow$ keys to obtain a DMM reading of '+V1' recorded in (d).
- iii. Correct by pressing the Cal key.

k. 4700

Set OUTPUT OFF.

Verify the 4700/4600 combination specification as detailed in Section 4, pages 4-13 to 4-15 (the DMM is already standardized at two points, and readings V0 and +V1 are already noted).

Slave AC Current Autocalibration

Full Range Checks

The Slave 4600 is calibrated by correcting its output. A Thermal Transfer Standard (TTS), in conjunction with a 10A shunt, is first nulled at the verified DC current output from the 4700/4600 combination.

We then switch the combination to output AC current at 300Hz, and adjust the 4700 OUTPUT display value to obtain a null on the TTS. The OUTPUT display value is corrected at this output by pressing the Cal key. The process is repeated at 5kHz.

Equipment Requirements

- The slaving 4700, AC voltage verified to suitable accuracy at 10V, 300Hz and 5kHz. Calibration of the 10A DC output of the same 4700/4600 combination must have been carried out within the previous 24 hours (preferably immediately before starting this AC calibration).
- A Calibrated AC 10A Thermal Transfer Current Shunt of suitable accuracy, of value 100mΩ [10mΩ].
Example: Holt HCS 1.
- A Thermal Transfer Standard of sufficient resolution and stability, for use in conjunction with the shunt.

CAUTION

When choosing a 10A current shunt, ensure that its rated power dissipation is sufficient to avoid permanent degradation from the self-heating effects of the current being checked.

Summary of AC Procedure

General

The 4600 is calibrated for two output currents: 10A RMS at 300Hz and 5kHz. The AC outputs are measured using a thermal transfer standard in conjunction with a precision current shunt of value 100mΩ [or 10mΩ], against the 4600 DC output used as reference current.

TTS Null to DC Reference Current

The OUTPUT I+ and I- terminals of the 4600 are connected to pass the output current to a thermal transfer standard, used in conjunction with a 10A current shunt. The TTS is first nulled for a DC reference current, derived by setting the 4700 output display for 10A DC output.

4600 AC Current Correction

The 4700/4600 combination is switched to output AC current at 300Hz. The 4700 OUTPUT display is adjusted so that the 4600 output current causes a null on the TTS. At this setting the 4600 is corrected by pressing the 4700 Cal key.

The correction is repeated at 5kHz.

Preparation

N.B. The following gives the full preparation assuming that DC Cal. has not been carried out. For best results the DC Cal. should immediately precede AC Cal., so some of the items will be unnecessary.

Before attempting any calibration ensure that the following steps have been carried out.

1. Before connecting and operating any equipment, consult the manufacturers' handbooks.
2. Check that the 4700 specification is verified for 10V output at 300Hz, 5kHz and 20kHz.
3. Check that the slaved 4700/4600 specification is verified for +10A DC output.
3. Comply with the instructions for 'Preparing the 4600 for Calibration' on page 5-3.
5. The 4600 front panel LEDs should show no errors present.

The procedure is detailed on pages 5-18/19.

Slave AC Current Calibration Procedure

First Null the TTS at 10A DC

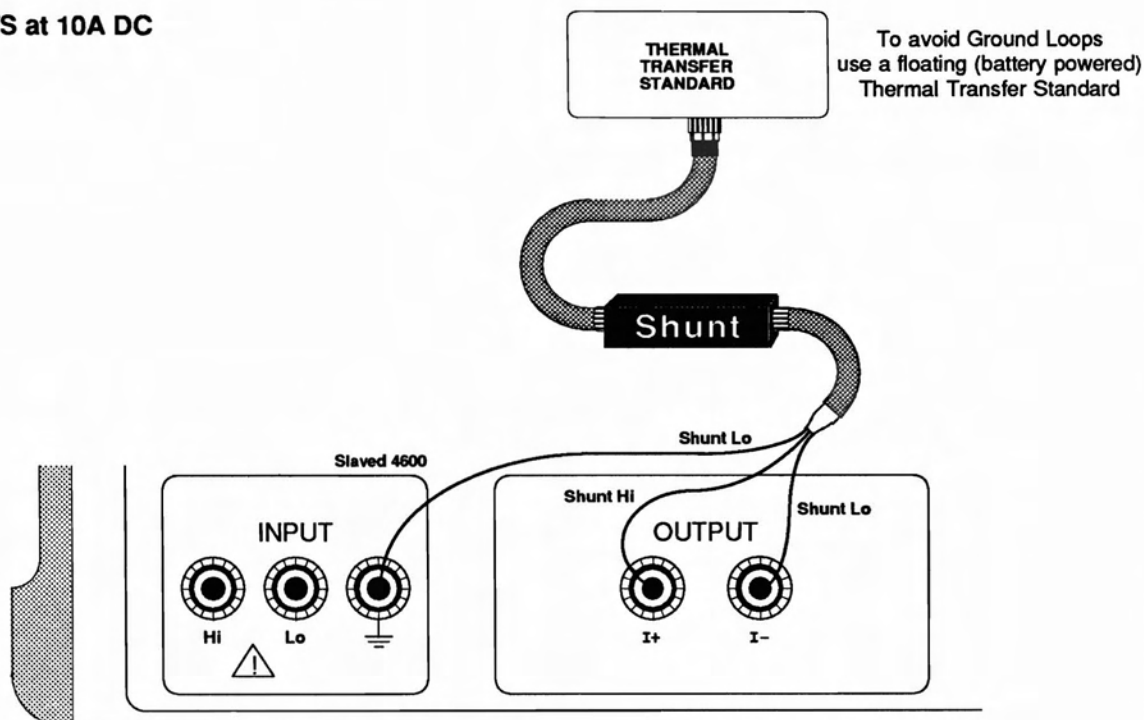

Ensure that the 4700/4600 combination is connected in Slave mode. Connect the shunt and TTS to the 4600 OUTPUT terminals as shown (ensure the connection of Shunt Lo to the 4600 INPUT ground).

Carry out operations (a) to (f):

- | | | | |
|---------|---|---------|---|
| a. 4700 | <ul style="list-style-type: none"> i. Ensure that OUTPUT is OFF, ii. FUNCTION to DC, I. iii. OUTPUT RANGE to 10, (Sense and Guard settings are internally controlled by firmware). iv. Press the Full Range key to set OUTPUT current to 10.0000A | d. 4600 | <ul style="list-style-type: none"> i. Press the OUTPUT ON+ key. Check that the 4700 and 4600 LEDs light and the TTS indicates. ii. Set OUTPUT OFF. Check that the 4700 and 4600 LEDs go out and the TTS indication falls to null. iii. Reset OUTPUT ON+. |
| b. TTS | Set range to maximum. | e. TTS | <ul style="list-style-type: none"> i. Adjust for a Null reading. ii. Allow the reading to stabilize. iii. Readjust for a Null reading. |
| c. 4700 | <ul style="list-style-type: none"> i. Press the OUTPUT ON+ key. Check that the 4700 and 4600 LEDs light and the TTS indicates. ii. Set OUTPUT OFF. Check that the 4700 and 4600 LEDs go out and the TTS indication falls to null. | f. 4600 | Set OUTPUT OFF. |

Correct the 4600 AC Output

Carry out operations (g) to (k):

- g. 4700
- i. Ensure that OUTPUT is OFF,
 - ii. Set FUNCTION to AC, I,
 - iii. Set FREQUENCY to 300Hz,
 - iv. Set OUTPUT RANGE to 10 (Sense and Guard settings are internally controlled by firmware).
 - v. Set OUTPUT current to 10.00000A RMS by pressing the Full Range key.
- h. TTS
- Set range to maximum.
- j. 4760
- i. Set OUTPUT ON.
 - ii. Use the OUTPUT \uparrow \downarrow keys to adjust the OUTPUT display reading for a Null reading on the TTS.
 - iii. Allow the reading to stabilize.
 - iv. Readjust OUTPUT for a Null reading on the TTS.
 - v. Correct at this frequency by pressing the Cal key.
 - vi. Set OUTPUT OFF.
- k. Repeat operations (h) and (j) at 5kHz.

Verify the 4700/4600 combination AC specification as detailed in Section 4, pages 4-17 to 4-19 (the TTS is already nulled).

Alternative AC Current Calibration

(Using a standardized AC DMM instead of a Thermal Transfer Standard)

Appendix 1 to:
4600 User's Handbook
Section 5.

N.B. Shunt Values

In this appendix, in the interests of clarity, an assumption is made that a 100mΩ shunt will be used. The shunt value and shunt voltage values are given for a 100mΩ shunt; values for a 10mΩ shunt are indicated by square braces [...].

Solo Mode

Full Range

The Solo 4600 is calibrated by correcting its transconductance. We use the ACRVS to input verified 10V RMS, and correct the output current at 10A RMS. A shunt converts the output current to a voltage, measured across the shunt using an AC DMM which we have first 'Standardized' to the ACRVS.

'Standardizing' ensures that the DMM is aligned to the ACRVS, at the expected values of shunt voltage. 10A will produce 1V across a 100mΩ shunt [100mV for a 10mΩ shunt]. The procedure compares the ACRVS settings used to standardize the DMM to the expected voltages, for the shunt value in use.

Equipment Requirements

- An AC Reference Voltage Source (ACRVS), calibrated to suitable accuracy for 10V and 1V [100mV] RMS at 5kHz.
Example: Datron 4200A, 4700 or 4708.
- A Calibrated 10A AC Current Shunt of suitable accuracy, of value 100mΩ [10mΩ].
- A DMM of sufficient resolution and stability, for use as a transfer device to measure the AC voltage across the shunt.
Example: Datron 1281, 1081 or 1071 with Option 10.

CAUTION

Ensure that the shunt's rated power dissipation is sufficient to avoid permanent degradation from the self-heating effects of the current being checked.

Summary of AC Procedure

General

The 4600 is corrected at 10A RMS at 5kHz, corresponding to an input voltage of 10V RMS. The output passes through a calibrated AC current shunt of value 100mΩ [10mΩ]; the resulting voltage is measured using a previously-standardized AC DMM.

DMM Standardization

The AC Reference Voltage Source at 5kHz is used to standardize the DMM at the expected nominal shunt voltage.

4600 AC Current Correction

The ACRVS 5kHz output at 10V RMS is then applied to the Solo 4600 INPUT terminals, whose OUTPUT terminals are connected to pass the output current through the shunt, with the DMM connected to measure the shunt voltage.

The 4600 internal 'HF Gain Compensation' trimmer capacitor C424 is adjusted until the DMM voltage reading represents nominal full range output into the shunt.

Preparation

Before attempting any calibration ensure that the following steps have been carried out.

1. Before connecting and operating any equipment, consult the manufacturers' handbooks.
2. Ensure that the ACRVS and DMM specifications verify at the following voltages:
ACRVS 1V [100mV] RMS; 10V RMS.
DMM 1V [100mV] RMS.
3. Comply with the instructions for 'Preparing the 4600 for Calibration' on page 5-3.
4. The 4600 front panel LEDs should show no errors present. Carry out any self-test routine on the ACRVS.

The procedure is detailed on pages 5-A1-2/3.

Solo AC Current Calibration Procedure

First Standardize the DMM at 1V [100mV]

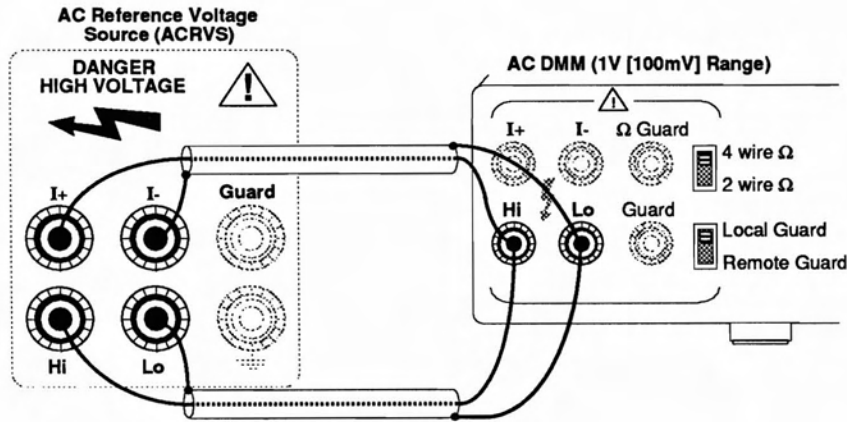

Connect the DMM to read the ACRVS output as in the above diagram. Ensure that the DMM Guard is set to **Local**.

Carry out operations (a) to (e):

- a. **ACRVS** Ensure that **OUTPUT** is **OFF**,
FUNCTION to **AC Voltage**,
FREQUENCY to **5kHz**,
OUTPUT RANGE to **1V [100mV]**,
Sense to **Remote**,
Guard to **Local**,
OUTPUT voltage to **1V [100mV] RMS**.
- b. **DMM** Set AC range to measure **1V [100mV] RMS**.
- c. **ACRVS** Set **OUTPUT ON**.
- d. **DMM** Note the reading as '**V5k**'.
- e. **ACRVS** Set **OUTPUT OFF**.

Correct the 4600 AC Output

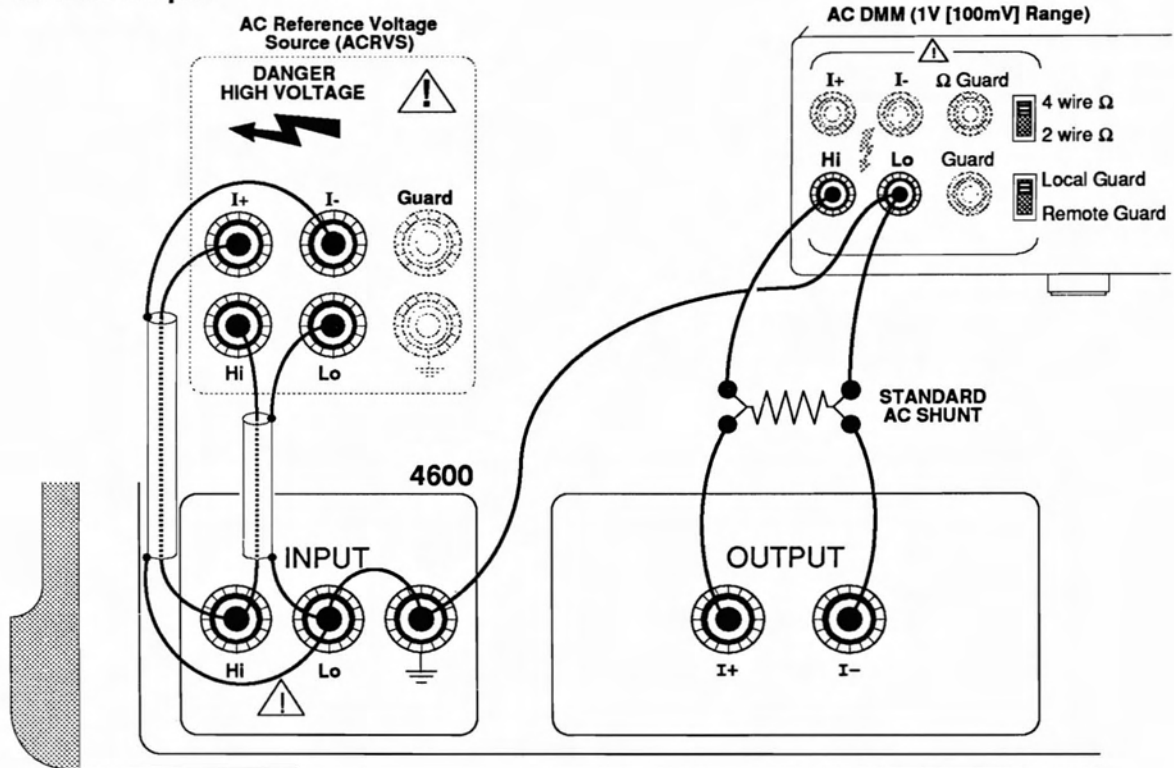

Connect the ACRVS, 4600, Shunt and DMM as shown in the above diagram (ensure the connection of DMM Lo to the 4600 INPUT ground).

Carry out operations (h) to (m):

- h. **ACRVS** Ensure that OUTPUT is OFF, FUNCTION to AC Voltage, FREQUENCY to 5kHz, OUTPUT RANGE to 10V, Sense to Remote. Guard to Local. OUTPUT voltage to 10.00000V RMS.
- j. **DMM** Set range 1V [100mV].
- k. **ACRVS** Set OUTPUT ON.
- l. **4600** Set OUTPUT ON. Lift the 4600 top cover and adjust the 'AC Flatness' trimmer capacitor C424 to obtain a DMM reading of 'V5k' noted in (e). Set OUTPUT OFF.
- m. **ACRVS** Set OUTPUT OFF.

Verify the Solo 4600 AC specification as detailed in Appendix 4 to Section 4.

Alternative AC Current Calibration (Contd)

(Using a standardized AC DMM instead of a Thermal Transfer Standard)

Slave Mode

Full Range Checks

The slaved 4600 is calibrated by correcting its output. We use the 4700 Cal mode to adjust the 4600 output current so that it agrees with the 4700 OUTPUT setting. A shunt converts the output current to a voltage, measured across the shunt using a DMM which we have first 'Standardized' to the 4700 voltage output.

'Standardizing' ensures that the DMM is aligned to the 4700 at the expected values of shunt voltage. 10A will produce 1V across a 100mΩ shunt [100mV across a 10mΩ shunt]. The procedure compares the 4700 settings used to standardize the DMM to the expected voltages, for the shunt value in use.

Equipment Requirements

- The slaving 4700, AC voltage verified to suitable accuracy for frequencies of 300Hz and 5kHz at 10V and 1V [100mV] RMS.
- A Calibrated 10A AC Current Shunt of suitable accuracy, of value 100mΩ [10mΩ].
- A DMM of sufficient resolution and stability, for use as a transfer device to measure the AC voltage across the shunt.
Example: Datron 1281, 1081 or 1071 with Option 10.

CAUTION

Ensure that the shunt's rated power dissipation is sufficient to avoid permanent degradation from the self-heating effects of the current being checked.

Summary of AC Procedure

General

The 4700/4600 combination is calibrated at 10A RMS for two output frequencies: 300Hz and 5kHz. The output passes through a precision AC current shunt of value 100mΩ [or 10mΩ]; the resulting voltages are measured by a previously-standardized AC DMM. The 4600 output is corrected at these two frequencies, and then verified in accordance with Section 4.

DMM Standardization

For each frequency the slaving 4700 is used to standardize the DMM at the expected nominal shunt voltage.

Slave AC Current Calibration

The 4600 is connected in Slave mode to the 4700. The 4600 OUTPUT terminals are connected to pass the output current through the shunt, with the DMM connected to measure the shunt voltage. The 4700 AC 10A OUTPUT RANGE is selected. For each frequency, its OUTPUT display is adjusted until the DMM voltage reading represents nominal full range output into the shunt. At this setting the 4700 Cal key is pressed.

Preparation

Before attempting any calibration ensure that the following steps have been carried out.

1. Before connecting and operating any equipment, consult the manufacturers' handbooks.
2. Ensure that the 4700 and DMM specifications verify at 300Hz and 5kHz for the following voltages:

4700	1V [100mV] RMS; 10V RMS.
DMM	1V [100mV] RMS.
3. Comply with the instructions for 'Preparing the 4600 for Calibration' on page 5-3.
4. The 4600 front panel LEDs should show no errors present. Press the 4700 Test key to carry out the self-test routine on the 4700/4600 combination.

The procedure is detailed on pages 5-A1-6/7.

Slave AC Current Calibration Procedure

First Standardize the DMM at 1V [100mV]

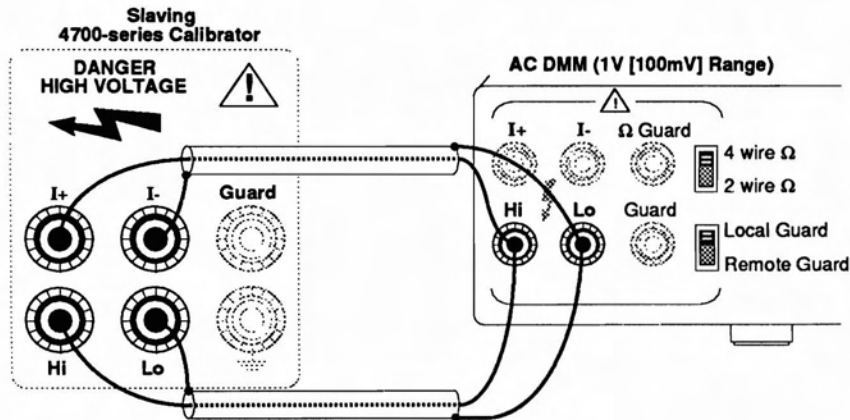

Connect the DMM to read the 4700 output as in the diagram. Ensure that the DMM Guard is set to Local.

Carry out operations (a) to (g):

- | | | | |
|---------|---|---------|----------------------------|
| a. 4700 | Ensure that OUTPUT is OFF, FUNCTION to AC, not I, FREQUENCY to 300Hz OUTPUT RANGE to 1 [100m], Sense to Remote. Guard to Local. OUTPUT voltage to 1V [100mV] RMS. | e. 4700 | Set FREQUENCY to 5kHz. |
| b. DMM | Set AC range to measure 1V [100mV] RMS. | f. DMM | Note the reading as 'V5k'. |
| c. 4700 | Set OUTPUT ON. | g. 4700 | Set OUTPUT OFF. |
| d. DMM | Note the reading as 'V300'. | | |

Correct the 4600 AC Output

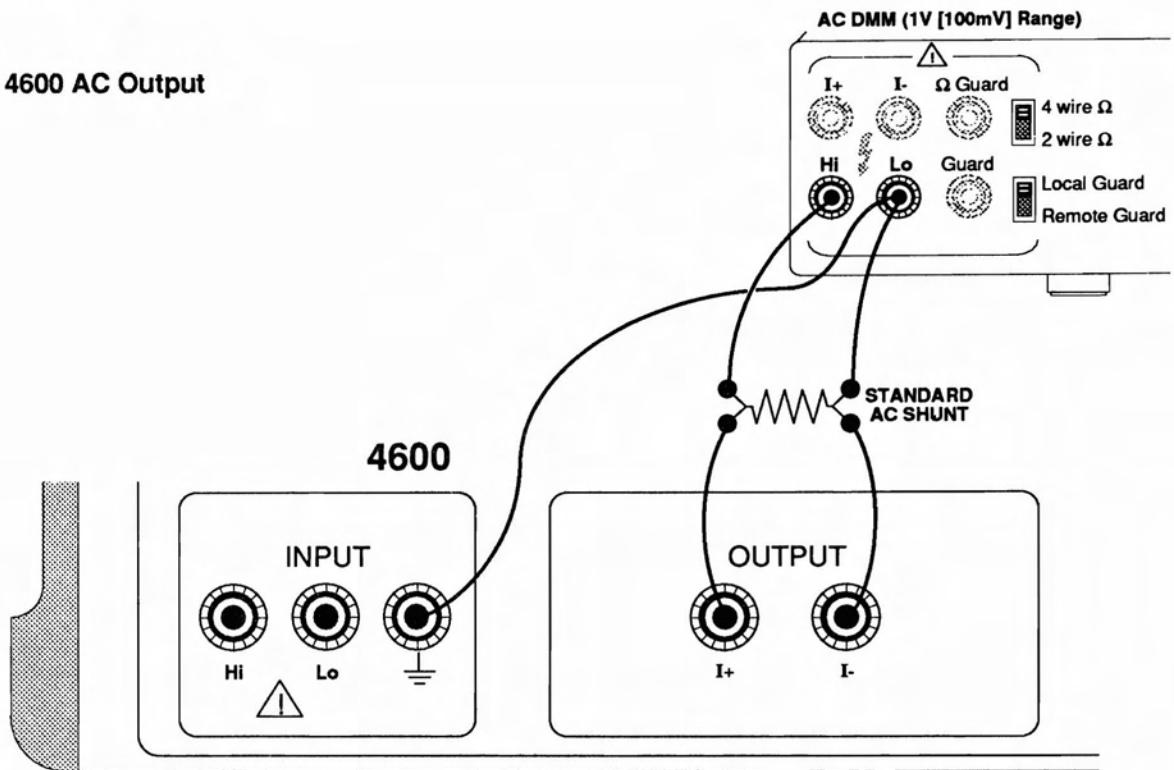

Connect the 4700 and 4600 in Slave Mode. Connect the Shunt and DMM to the 4600 as shown in the above diagram (ensure the connection of DMM Lo to the 4600 INPUT ground).

Carry out operations (h) to (m):

- h. 4700 Ensure that OUTPUT is OFF,
FUNCTION to AC, I,
FREQUENCY to 300Hz,
OUTPUT RANGE to 10A,
OUTPUT current to 10A RMS.
(Sense and Guard are controlled by software.)
- j. DMM Set range to 1V [100mV].
- k. 4600 Set OUTPUT ON.
- l. 4700 Using $\uparrow\downarrow$ keys, adjust OUTPUT display to
obtain a DMM reading of 'V300' noted in (d).
Correct at 300Hz by pressing the 4700 Cal key.
- m. 4700 Reset FREQUENCY to 5kHz.
Using $\uparrow\downarrow$ keys, adjust OUTPUT display to
obtain a DMM reading of 'V5k' noted in (f).
Correct at 5kHz by pressing the 4700 Cal key.

Verify the Slave 4600 AC specification as in Appendix 4 to Section 4.

i

)

)

)

)

)

)

)

)

)

)

)

)

)

)

)

)

)

)

i

SECTION 6 FAULT DIAGNOSIS

WARNING

HAZARDOUS ELECTRICAL POTENTIALS ARE EXPOSED WHEN THE INSTRUMENT COVERS ARE REMOVED. ELECTRIC SHOCK CAN KILL

CAUTION

The instrument warranty can be invalidated if damage is caused by unauthorised repairs or modifications. Check the warranty detailed in the "Terms and Conditions of Sale". It appears on the invoice for your instrument.

6.1 INTRODUCTION

6.1.1 Use of Diagnostic Guides

The diagnostic guides given in Section 6.2 are intended to aid the user in locating a failed printed circuit board or other sub-assembly. The self-diagnostic capabilities of the instrument provide the first step in fault analysis by lighting a warning LED on the Front Panel, and if in Slave mode this is accompanied by a FAIL message on the mode display of the slaving 4700-series calibrator. Initial actions to be taken after the occurrence of a reported fault are given, where applicable, in the diagnostic guides of Section 6.2. The lit LED or FAIL message localizes the failure into a distinct functional area and the 'Fault Condition' summary in each guide relates the function failure to a probable hardware boundary.

The identities of the sub-assemblies involved in the failure are given beneath the fault condition summary, but it is unlikely that all assemblies listed will prove to be faulty. For successful failure analysis, it is advisable to be familiar with the electronic functioning of the instrument and with the physical location of the assemblies. To assist in these aspects, the diagnostic guides include references to relevant parts of this publication.

6.1.2 Effects of Protection on Diagnosis

The 4600 incorporates built-in protection. To minimize damage, protective circuitry acts immediately, and if in Slave mode this is backed up by a pre-programmed CPU response in the slaving 4700 to detected failure symptoms. If possible the CPU informs the user by presenting a failure message on the MODE display.

When investigating a failure, it should therefore be anticipated that protective measures will have suppressed the original fault conditions. A useful starting-point is to identify the origin of the failure message to localize the area of search.

6.1.3 Self-Test Sequence

Refer to Section 9.4.5, page 9.4-13.

6.1.4 Fuses and their Locations

Sub-section 6.3 lists the external and internal fuses; together with their locations, protected circuits and page references.

6.2 DIAGNOSTIC GUIDES

6.2.1 Overtemp LED Lit (FAIL 1)

(Excessive Heatsink Temperature)

AUTOMATIC INITIAL ACTION

1. The 4600 will have defaulted to OUTPUT OFF, and disabled the SMPS.
If in Slave mode the 4700 will also have defaulted to OUTPUT OFF.
No immediate user-action is required.

RECOVERY ACTION

After the temperature returns to normal, the Overtemp LED goes off (and the FAIL 1 message on the 4700 is cleared if in Slave mode) so an attempt can be made to restore Output On:

Solo Mode

1. Press the 4600 OUTPUT ON key. Once approximately 1 minute has passed since the Overtemp LED went off, the PSUEN delay will have timed out, and the output will be sequenced on again.
2. Overtemp LED remains unlit - no further action. If the LED relights - fault persists.

Slave Mode

1. Ensure that the 4700 10A range is selected. Press the 4700 or 4600 OUTPUT ON key. Once approximately 1 minute has passed since the Overtemp LED went off, the PSUEN delay will have timed out, and the output will be sequenced on again.
2. Overtemp LED remains unlit and FAIL 1 message does not appear - no further action. If the LED relights and the FAIL 1 message recurs - fault persists.

FAULT CONDITION

Excessive temperature has been sensed in the Output PCB Heatsink Assembly.

Inguard fault-indication signal OVTP_H asserts OVTEMP_H outguard, which drives the sequence controller U204. An Off sequence is initiated, due to U204 resetting the Key Latch and On Latch. The sequence reverts to S1 state, whether in Slave or Solo mode. While OVTEMP_H remains set, it is gated inside U204 to set PSUEN_H false, disabling the Switch Mode Power Supply. Note that although the SMPS has been turned off, this was not due to the LTPSUFL signal being set true, so the Psu LED on the 4600 front panel remains green.

In Slave mode, the OVTEMP_H signal is one of those polled by the 4700 via U111. If the poll discovers that OVTEMP_H is set, the 4700 CPU turns its OUTPUT OFF and presents the FAIL 1 message on its MODE display.

RECOVERY CONDITION

If the overtemperature was due to external factors; such as the airway behind the instrument being blocked, or it being enclosed so that the exhaust air is drawn back into the intake; then once these have been corrected, the output on condition can be recovered. This is controlled by the digital sequencing as follows:

The temperature in the Output PCB Heatsink Assembly falls below the sensor trip threshold; the Overtemp LED goes out, (and if in Slave mode the FAIL 1 message is cleared).

OVTP (and thus OVTEMP) reverting to false releases the resets on the Key Latch and On Latch.

Subsequent action depends on which mode was selected at the time of the overtemperature:

Solo Mode (at least one of the bus cables disconnected)

From state S1, OVTP false forces transition to state S2 (see the state diagram on *page 9.4-4*). PSUEN goes true, so the SMPS switches on. The instrument output was latched off by the overtemperature resetting the Key Latch, so the OUTPUT ON key needs to be pressed for total recovery. Although this sets the Key Latch, it cannot turn the output on until the PSUEN delay (U202-10) has timed out after approximately 1 second from PSUEN going true, setting the PODLY signal false. Then, providing the Key Latch is set, the sequence transits through to S5 state, and the output is turned on.

Slave Mode (both bus cables connected)

From state S1, OVTP false (with the bus cables connected) forces transition to state R1 (see the state diagram on *page 9.4-4*). If the 10A range is selected on the 4700, then CK_SELBIT is true, and the sequence transits to R2 state. PSUEN goes true, so the SMPS switches on. The instrument output was latched off by the overtemperature resetting the On Latch, so the 4600 or 4700 OUTPUT ON key needs to be pressed for total recovery. Although this sets the On Latch, it cannot turn the output on until the PSUEN delay (U202-10) has timed out after approximately 1 second from PSUEN going true, setting the PODLY signal false. Then, providing the On Latch is set, the sequence transits through to R5 state, and the output is turned on.

If the cause of the overtemperature has not been cleared, then excessive temperature will be detected and the output will sequence off again.

POSSIBLE FAULT LOCATIONS

- External heat-retaining factors, such as the airway behind the instrument being blocked, or it being enclosed so that the exhaust air is drawn back into the intake.
- Blocked air-intake filter.
- Internal cooling-air fan inoperative.
- Output PCB (*page 10.1-14*)
- SMPS Main PCB (*page 10.1-16*)

It is unlikely for the SMPS to be the cause of an overtemperature. Because the $\pm 7.5V$ supply is current-fed, the SMPS heatsink should not overheat unless the Output PCB has also overheated.

FURTHER INFORMATION IN THIS HANDBOOK

Technical Descriptions:

Section 9.2 - Analog (especially 9.2.4)

Section 9.4 - Digital (especially 9.4.5)

6.2.2 Psu LED Lit (FAIL 9)

(Power Supply Failure)

AUTOMATIC INITIAL ACTION

1. The 4600 will have defaulted to OUTPUT OFF, and disabled the SMPS.
If in Slave mode the 4700 has defaulted to OUTPUT OFF.

RECOVERY ACTION

Although unlikely, it is possible that a very severe 'Glitch' in the line supply could cause one of the power supplies to operate its failure detector. Because of this, it is worth an attempt to recover the situation before removing covers to investigate. To do this we must clear the CK_LTPSUFL latch in U204 (Sense PCB):

Solo Mode

1. Set the Front Panel Power switch to OFF, then ON again.
2. Psu LED lights and remains green - no further action. If the LED lights red - fault persists.

Slave Mode

1. Press the 4700 Reset key.
2. Select the 10A range.
3. 4600 Psu LED lights and remains green and FAIL 9 message does not appear - no further action. If the LED lights red and the FAIL 9 message recurs - fault persists.

FAULT CONDITION

One of four failures of in-guard power supplies has been detected:

1. An overvoltage or undervoltage has been sensed in the SMPS Control PCB when the SMPS was enabled by PSUEN true, and has set fault-indication signal SMPS_FAIL true.

or:

2. Failure of the 15V_2 supply has been sensed by Q9 on the SMPS Control PCB setting signal PSUFAIL_2 true.

or:

3. Failure of the 15V_3 supply has been sensed by Q309 on the Sense PCB setting fault-indication signal PSUFAIL_3 true.

or:

4. Excessive power in the SMPS tank circuit has been sensed in the outguard secondary of T3 on the SMPS Main PCB. The excessive rectified output voltage of T3 (signal PWR_SIG) has been detected by comparator U315 on the Sense PCB, setting outguard fault-indication signal OVPWR true.

The SMPS_FAIL, PSUFAIL_2 and PSUFAIL_3 signals are ORed by U319 on the Sense PCB to generate the PSUFL signal, so that if any one or more of the three failures occurs, then PSUFL is set true.

PSUFL is passed out of guard and ORed with the OVPWR signal; the resulting signal drives the sequence controller U204 to generate the latched signal CK_LTPSUFL true at the next 30ms clock. An Off sequence is initiated, due to U204 resetting the Key Latch and On Latch. The sequence reverts to S1 state, whether in Slave or Solo mode. While CK_LTPSUFL true remains latched, it is gated inside U204 to set PSUEN false, disabling the Switch Mode Power Supply. Note in this case the SMPS has been turned off due to the LTPSUFL signal being set true, so the Psu LED on the 4600 front panel changes to red.

In Slave mode, the CK_LTPSUFL_H signal is one of those polled by the 4700 via U111. If the poll discovers that CK_LTPSUFL_H is set, the 4700 CPU commands OUTPUT OFF and presents the FAIL 9 message on its MODE display.

POSSIBLE FAULT LOCATIONS

- SMPS Control PCB page (10.1-18).
- SMPS Main PCB (page 10.1-16).
- Sense PCB (page 10.1-4).
- Output PCB (page 10.1-14).

It is unlikely that a real fault can be cleared without removing the covers, if only to access a blown fuse.

FURTHER INFORMATION IN THIS HANDBOOK

Technical Descriptions:

Section 9.2 - Analog (especially 9.2-4).

Section 9.3 - SMPS.

Section 9.4 - Digital (especially 9.4.5).

Section 9.5 - Power Supplies.

6.2.3 Overdrive LED Lit (Error OL)

(Excessive Input Reference Voltage or Frequency)

AUTOMATIC INITIAL ACTION

1. The 4600 will have defaulted to OUTPUT OFF; the SMPS remains enabled.
If in Slave mode the 4700 will also have defaulted to OUTPUT OFF; the Reference Voltage is switched off.
No immediate user-action is required.

RECOVERY ACTION

After the Input Reference Voltage falls to zero, the Overdrive LED goes off (and the Error OL message on the 4700 is cleared if in Slave mode) so an attempt can be made to restore Output On after reducing the Reference Voltage to within limits:

Solo Mode

1. Press the 4600 OUTPUT ON key. The output will be sequenced on again.
2. Overdrive LED remains unlit - corrective action was successful. If the LED relights - fault persists.

Slave Mode

1. Ensure that the 4700 10A range is selected. Press the 4700 or 4600 OUTPUT ON key. The output will sequence on again.
2. Overdrive LED remains unlit and FAIL 1 message does not appear - corrective action was successful. If the LED relights and the FAIL 1 message recurs - fault persists.

FAULT CONDITION

Excessive Input Reference Voltage has been sensed at the output of the differential input amplifier on the Sense PCB (Vin).

Inguard fault-indication signal OVDR_H has been set true by the Overdrive Detector on the Sense PCB, and passed outguard to turn on the Overdrive LED and drive the sequence controller U204. An Off sequence is initiated, due to U204 resetting the Key Latch and On Latch. If in Solo mode the sequence reverts to S2 state, if in Slave mode to R2 state (because PSUFL and OVTP are still false, the sequence does not transit to S1 state). PSUEN_H remains true, so the Switch Mode Power Supply is not disabled.

OVDR and the stretched Overload signal are ORed in U204 to generate the signal OVDRLD_H. In Slave mode, the OVDRLD_H signal is one of those polled by the 4700 via U111. If the poll discovers that OVDRLD_H is set, the 4700 CPU turns its OUTPUT OFF and presents the Error OL message on its MODE display.

RECOVERY CONDITION

If the overdrive was due to the Input Reference Voltage to the 4600 being excessive; then once this has been corrected, the output on condition can be recovered. This is controlled by the digital sequencing as follows:

Vin falls below the sensor trip threshold; the Overdrive LED goes out, (and if in Slave mode the Error OL message is cleared).

OVDR reverting to false releases the resets on the Key Latch and On Latch.

Subsequent action depends on which mode was selected at the time of the overdrive:

Solo Mode (at least one of the bus cables disconnected)

The instrument output was latched off by the overdrive resetting the Key Latch, so the OUTPUT ON key needs to be pressed for total recovery. As the PSUEN signal is still true, the PODLY signal is false. Then, providing the Key Latch is set, the sequence transits through to S5 state, and the output is turned on.

Slave Mode (both bus cables connected)

If the 10A range remained selected on the 4700, then CK_SELBIT is true, and the sequence is in R2 state. PSUEN is true, so the SMPS is on. The instrument output was latched off by the overdrive resetting the On Latch, so the 4600 or 4700 OUTPUT ON key needs to be pressed for total recovery. As the PSUEN signal is still true, the PODLY signal is false. Then, providing the On Latch is set, the sequence transits through to R5 state, and the output is turned on.

If the cause of the overdrive has not been cleared, then excessive Vin will be detected and the output will sequence off again.

POSSIBLE FAULT LOCATIONS

- Excessive Input Reference Voltage.
- Sense PCB (page 10.1-4)

Although the most probable cause of an overdrive is an excessive input voltage, it is possible for a fault to exist (eg. in the input differential amplifier) to cause Vin to be excessive; or a fault may exist in the detector itself. This will show up if the Overdrive LED remains lit after the input has been reduced (in Slave mode after the OFF key LEDs have lit on the 4600 and 4700).

FURTHER INFORMATION IN THIS HANDBOOK

Technical Descriptions:

Section 9.2 - Analog (especially 9.2.3)

Section 9.4 - Digital (especially 9.4.5)

6.2.4 Overload LED Lit (Error OL)

(Excessive Output Terminal Voltage - overcompliance)

AUTOMATIC INITIAL ACTION

1. The 4600 will have defaulted to OUTPUT OFF; the SMPS remains enabled.

If in Slave mode the 4700 will also have defaulted to OUTPUT OFF; the Reference Voltage is switched off.

No immediate user-action is required.

RECOVERY ACTION

After the Output Voltage falls to zero, the Overload LED goes off (and the Error OL message on the 4700 is cleared if in Slave mode) so an attempt can be made to restore Output On after the fault conditions have been cleared:

Solo Mode

1. Press the 4600 OUTPUT ON key. The output will be sequenced on again.
2. Overload LED remains unlit - corrective action was successful. If the LED relights - fault persists.

Slave Mode

1. Ensure that the 4700 10A range is selected. Press the 4700 or 4600 OUTPUT ON key. The output will sequence on again.
2. Overload LED remains unlit - corrective action was successful. If the LED relights - fault persists.

FAULT CONDITION

Excessive Output Voltage has been sensed at the I+ contact of the Output Relay.

Inguard fault-indication signal OVLD_H has been set true by the Overload Detector on the Sense PCB, and passed outguard to turn on the Overload LED and drive the sequence controller U204. An Off sequence is initiated, due to U204 resetting the Key Latch and On Latch. If in Solo mode the sequence reverts to S2 state, if in Slave mode to R2 state (because PSUFL and OVTP are still false, the sequence does not transit to S1 state). PSUEN_H remains true, so the Switch Mode Power Supply is not disabled.

The Overload signal is stretched by U202-7 (so that a poll from the 4700 has time to acquire it) and ORed with OVDR in U204 to generate the signal OVDRLD_H. In Slave mode, the OVDRLD_H signal is one of those polled by the 4700 via U111. If the poll discovers that OVDRLD_H is set, the 4700 CPU turns its OUTPUT OFF and presents the Error OL message on its MODE display.

RECOVERY CONDITION

If the overload was due to the 4600 being presented with too high an output impedance; then once this has been corrected, the output on condition can be recovered. This is controlled by the digital sequencing as follows:

The output current has been switched off, so the output voltage falls to zero; the Overload LED goes out, (and if in Slave mode the Error OL message is cleared).

OVLd reverting to false releases the resets on the Key Latch and On Latch.

Subsequent action depends on which mode was selected at the time of the overload:

Solo Mode (at least one of the bus cables disconnected)

The instrument output was latched off by the overload resetting the Key Latch, so the OUTPUT ON key needs to be pressed for total recovery. As the PSUEN signal is still true, the PODLY signal is false. Then, providing the Key Latch is set, the sequence transits through to S5 state, and the output is turned on.

Slave Mode (both bus cables connected)

If the 10A range remained selected on the 4700, then CK_SELBIT is true, and the sequence is in R2 state. PSUEN is true, so the SMPS is on. The instrument output was latched off by the overload resetting the On Latch, so the 4600 or 4700 OUTPUT ON key needs to be pressed for total recovery. As the PSUEN signal is still true, the PODLY signal is false. Then, providing the On Latch is set, the sequence transits through to R5 state, and the output is turned on.

If the cause of the overload has not been cleared, then an excessive output voltage will be detected and the output sequences off again.

POSSIBLE FAULT LOCATIONS

- Load impedance too high.
- Output sense loop open-circuit.
- Output PCB (page 10.1-14)

Although the most probable cause of an overload is a load with too high an impedance, it is possible for a fault to exist (eg. within the Sense loop) to cause overcompliance; or a fault may exist in the overload detector itself. This will show up if the Overload LED lights when the output is switched on after the load impedance has been reduced.

FURTHER INFORMATION IN THIS HANDBOOK

Technical Descriptions:

Section 9.2 - Analog (especially 9.2.5)

Section 9.4 - Digital (especially 9.4.5)

6.2.2 Solo LED Lit with FAIL 10 when Slave Mode should be Active

(Slaving Failure)

AUTOMATIC INITIAL ACTION

1. The 4600 will have defaulted to OUTPUT OFF; the SMPS remains powered on.

If in Slave mode the 4700 defaulted to OUTPUT OFF.

RECOVERY ACTION

It is most likely that one of the two interconnecting bus cables has become disconnected or faulty, or that a digital failure has disconnected the ANABUS_ON or DIGBUS_ON signals.

Slave Mode

1. Set the 4600 and 4700 Power switches to OFF.
2. Check the two bus cables and reconnect if necessary.
3. Set the 4600 and 4700 Power switches to ON.
4. Select the 10A range.
5. If the 4600 Solo LED does not light and FAIL 10 message does not appear - no further action. If the Solo LED lights and the FAIL 10 message recurs - fault persists.

FAULT CONDITION

The Bus On Decode circuit on the Sense PCB has generated the signal BUSON_L false. This drives Sequence Controller U204 to latch CK_BUSON false; this is an input to the Sequencer U206. Whatever 'R' state the sequence was in, it will have transferred to Solo state S2 (unless there is also a power supply failure or overtemperature, in which case it will have entered S1 state) and the Solo LED has been lit.

In U204, CK_BUSON false causes the CLR_ON and CLR_CTRL signals to become true, so that both the On Latch and Control Latches are reset.

CK_BUSON false also sets CLR_LTKEY false and releases the reset on the Key Latch which was part of the Slaving conditions.

POSSIBLE FAULT LOCATIONS

- One of the external bus cables disconnected or faulty.
- Sense PCB (page 10.1-4).

FURTHER INFORMATION IN THIS HANDBOOK

Technical Descriptions:

Section 9.4 - Digital (especially 9.4.2).

6.3 FUSE PROTECTION

In addition to the electronic protection devices used in the instrument, fuses are provided to protect against catastrophic component failure.

6.3.1 Fuse Replacement

A blown fuse is merely a symptom of failure, in the large majority of cases the cause lies elsewhere.

CAUTION

Every occurrence of a blown fuse should be investigated to find the cause. Only when satisfied that the cause has been removed, should a user replace a fused link by a serviceable item.

6.3.2 Reasons For Fusing

The fuses in the calibrator fall into two groups:

- a. Clip-in anti-surge fuses in the Power Supplies and Mother Board protect the power sources from damage.
- b. A soldered-in thermal fuse F2 is used in the SMPS Main PCB to protect against the effects of relay RL3 failure during normal operating conditions. It senses the temperature of the inrush limiting resistor which should be shorted after the initial SMPS power on.

6.3.3 Locating a Blown Fuse

The ultimate causes of blown fuses are so numerous that it is impractical to list them. In many cases the underlying cause, or the blown fuse itself, will activate an electronic protective process which can conceal some of the symptoms.

Fault location in the 4600 should proceed from the primary indications of fault condition (e.g. failure messages described in Section 6.2). These will lead to particular areas of investigation, and at this point the relevant circuit fuses should be checked first. Whether fuses are blown or not, the checks will add to the information available for further diagnosis. The types of fuses to be used can be found in the component lists of Section 10.

Table 6.1 below lists their values and locations.

Location and Designator	Value/Fitting	Protected Circuits	Page
Rear Panel - Power Input Module			
220/240V	2.5A/Littlefuse/Clip-in	Line Supply Main Fuse	2-1
100/120V	5A/Littlefuse/Clip-in	Line Supply Main Fuse	2-1
Sense PCB			
F501	1A/20mm/Clip-in	+5V_REG Main 5V Supply	10.1-13
F502	1A/20mm/Clip-in	+15V_REG Main 15V Supply	10.1-13
F503	1A/20mm/Clip-in	-15V_REG Main 15V Supply	10.1-13
SMPS Main PCB			
F1	2A/20mm/Clip-in	Power Switch High Voltage Supply Line	10.1-16
F2	147°C/Thermal/Soldered	SMPS Input Line	10.1-16
SMPS Control PCB			
F1	500mA/20mm/Clip-in	-22V(2) Supply Line	10.1-18
F2	500mA/20mm/Clip-in	+22V(2) Supply Line	10.1-18
Front PCB			
F101	500mA/20mm/Clip-in	Mains Transformer Input	10.1-20

Table 6.1 Fuse Location and Purpose

SECTION 7

DISMANTLING AND REASSEMBLY

This section contains information and instructions for dismantling the Datron 4600 to sub-assembly level. Reassembly is generally the reverse of dismantling, but where it may be helpful, additional notes are given.

7.1 General Precautions

7.1.1 WARNING

ISOLATE THE INSTRUMENT FROM THE LINE SUPPLY BEFORE ATTEMPTING ANY DISMANTLING OR REASSEMBLY.

7.1.2 CAUTIONS

1. THE FOLLOWING ACTIONS INVALIDATE THE MANUFACTURER'S CALIBRATION CERTIFICATION: REMOVAL OF THE BOTTOM GROUND/GUARD ASSEMBLY, REPLACEMENT OF SUB-ASSEMBLIES, OR PHYSICAL MOVEMENT OF COMPONENTS.
2. HANDLE THE INSTRUMENT CAREFULLY WHEN PARTIALLY DISMANTLED, TO AVOID SHAKING UNSECURED ITEMS LOOSE.
3. DO NOT TOUCH THE CONTACTS OF ANY PCB CONNECTORS.
4. ENSURE THAT NO WIRES ARE TRAPPED WHEN FITTING GROUND/GUARD ASSEMBLIES OR LIDS.
5. DO NOT ALLOW WASHERS, NUTS, ETC. TO FALL INTO THE INSTRUMENT.

7.2 General Mechanical Layout

Assembly Drawings in Section 10, pages 10.2-2 to 10.2-9: DA400785 (Finished Assembly) and DA400786 (Instrument Assembly); show how the 4600 is broken down into sub-assemblies.

7.2.1 Front Panel

The Front Panel layout is illustrated in Section 3, Page 3-1.

Three INPUT terminals and two OUTPUT terminals are provided, for connection to the Reference Voltage Source (Solo) and Load, respectively.

Two pushbutton switches are provided for setting the output on and off. Each houses a red LED.

Six other LEDs are arranged in a panel above the switches; the Psu LED is green/red, the other five are red.

The line power is turned on and off by a toggle on the right side of the Front Panel.

A printed overlay labels all the front panel features.

7.2.2 Rear Panel

(All directions as viewed from the rear of the instrument)

The Rear Panel layout is illustrated in Section 3, Page 3-2.

The recessed Power Input plug, Power Fuse and Line Voltage Selector are contained in an integral module at the left of the panel.

The cooling air intake filter is screwed on to the outside of the panel at the right side; the exhaust vents and louvres occupy the left side of the panel, above and to the right of the Power Input Module.

The instrument identification label is situated between the intake filter and the exhaust louvres, and directly below the panel is the 15-way D-type digital slave input plug J54.

The 6-way 'LEMO' analog slave input plug J66 is located on the extreme right of the panel.

7.3 Location and Access

7.3.1 External Construction

Both the front and rear panels are held together by two side extrusions running from front to rear. These extrusions provide slots for the handles or rack mounting 'ears', and locating points for the structural foam covers.

The bottom cover is fitted with the tilt-stand and four rubber feet. Ground screening of the covers is provided by steel plates, heat-staked to the inside of the covers with electrical connections made by spring contacts.

7.3.2 Internal Construction

Internal Supports

Four supports are secured to the front panel, rear panel and side extrusions:

(Page 10.2-5, Assembly Drawing DA400786 Sheet 1)

- (Part no. 450684)
A complex angled steel bracket acts as the main internal support. As well as supporting the right side of the Sense PCB, three corners of the Output PCB and the front of the SMPS box, it also carries the mains transformer and the cooling fan. It is screwed to both the rear panel and the right extrusion.
- (Part no. 450621)
Screwed to the left extrusion, a full-length steel bracket has a right-angled extension at the front to carry the three INPUT terminals. Its bottom edge, fitted with four swaged nuts, is turned up at 90° to form attachments for the left side of the Sense PCB.

(Page 10.2-7, Assembly Drawing DA400786 Sheet 3)

- (Part no. 450685)
A steel angle bracket is screwed into the rear of the right extrusion. It supports the rear of the SMPS screening box, and the SMPS within.

(Page 10.2-15, Assembly Drawing DA400856)

- (Part no. 450705)
The fourth support is an angled aluminium plate, screwed to the rear panel between the exhaust vents and louvres, supports a corner of the Output PCB.

A support for the Sense resistor, Output relay and the two Output terminals, mounted on the Sense PCB, is also secured to the Front Panel.

Printed Circuit Boards

The instrument contains five printed circuit boards:

- **Sense PCB:** fitted component side up at the bottom of the left side of the instrument.
- **Output PCB:** fitted component side up at the bottom rear of the right side of the instrument, inboard of the SMPS screening box. A double-sided, finned heatsink is mounted at top center of the PCB, in the direct airflow from the cooling-air fan.
- **SMPS Main PCB:** fitted within its screening box on the rear right side of the instrument.
- **SMPS Control PCB:** fits vertically into slots on top of the SMPS Main PCB, within the screening box. A finned heatsink is mechanically and thermally attached to the left of the box, overlapping the right side of the Output PCB, in the direct airflow from the cooling-air fan.
- **Front Panel PCB:** fitted behind the Front Panel, on the right side of the instrument.

Cooling Airflow

The cooling-air fan is positioned on the front lateral part of the center support. Ambient air is drawn into the instrument from the external intake filter on the Rear Panel, through the front/left side cavity, and forced rearwards through the Output PCB and SMPS Box heatsinks to be expelled through the vents and louvres in the Rear Panel. The louvres deflect the airflow away from the intake filter.

The construction around the heatsinks forms an enclosed duct, bounded on the left by the center support and on the right by the SMPS Box (drilled to allow airflow across the SMPS high power components). The Output PCB forms the bottom, and the top is sealed by a flat foam insulator. This minimizes leakage of the heated air from the sinks back into the rest of the instrument.

Mains Transformer Assembly

This is a self-contained unit, all its connections being made to the Front PCB by removable Molex sockets. It is mounted with insulators and retainer onto a thick spindle, which is secured by a countersunk screw to the front of the lateral section of the center support. The other end of the spindle is extended as a thin stub, which locates into a hole in the front PCB. The orientation of the transformer body is set at manufacture using foam pads, an endplate and a Nylock nut to secure it to the spindle.

Bus-bars

A feature of the internal appearance of the instrument is the presence of silver-colored bus-bar strips, which provide a low resistance path for the high output current. Bends position them correctly, and where they run close together, they are separated by insulating foam spacers.

7.4 General Access

- ENSURE THAT POWER IS OFF.
- Heed the General Precautions 7.1.1 and 7.1.2.

If, during a procedure, sufficient access has been obtained, then no further dismantling is required.

7.4.1 Top Cover

- **Removal**
 - a. Remove the four M4 x 12mm socket-head countersunk screws from the cover.
 - b. Remove the cover by lifting at the front.

- **Fitting**

Locate the cover at the rear first, then reverse the removal procedure, ensuring that the foam insulation is correctly located.

7.4.2 Bottom Cover

- **Removal**
 - a. Invert the instrument.
 - b. Remove the four M4 x 12mm socket-head countersunk screws from the cover.
 - c. Remove the cover by lifting at the front.

- **Fitting**

Locate the cover at the rear first, then reverse the removal procedure, ensuring that the foam insulation is correctly located.

7.4.3 Insulation Pieces

- Remove top and bottom covers: 7.4.1 and 7.4.2.
- **Removal**
 - a. (Page 10.2-2, DA400785 Sheet 1)
Stand the instrument in its normal upright position.
 - b. Lift the top foam insulating sheet (Part No. 450637), easing it out from under the lip of the center support, and remove.
 - c. (Page 10.2-3, DA400785 Sheet 2)
Invert the instrument.
 - d. Lift the bottom foam insulating sheet (Part No. 450732), easing it out from under the Rear Panel lip and Cover Contact, and remove.
 - e. Lift the back foam insulating sheet (Part No. 450734), easing it out from under the Rear Panel lip and Cover Contact, and remove.

- **Fitting**

Reverse the removal procedure, ensuring that the foam insulating sheets are correctly located under the lips of the relevant Panel and Support.

7.4.4 Top Finger Plate

WARNING: This prevents operators' fingers contacting the line voltage points on the Front PCB.
DO NOT REMOVE the plate while the line power is connected to the instrument!

- Remove top and bottom covers: 7.4.1 and 7.4.2.
- Remove insulating pieces: 7.4.3.

- **Removal**

- a. (Page 10.2-2, DA400785 Sheet 1)
Stand the instrument in its normal upright position.
- b. Remove two countersunk screws securing the finger plate to the SMPS Box, noting which two screwholes in the plate are used. Remove the finger plate.

7.4.5 Bottom Finger Plate

WARNING: This prevents operators' fingers contacting the line voltage points on the Front PCB.
DO NOT REMOVE the plate while the line power is connected to the instrument!

- Remove top and bottom covers: 7.4.1 and 7.4.2.
- Remove insulating pieces: 7.4.3.

- **Removal**

- a. (Page 10.2-3, DA400785 Sheet 2)
Invert the instrument.
- b. Remove two countersunk screws securing the finger plate to the SMPS Box, noting which two screwholes in the plate are used. Remove the finger plate.

7.4 General Access *(Contd)*

7.4.6 Front Panel Assembly

- Remove top and bottom covers: 7.4.1 and 7.4.2.
- Remove insulating pieces: 7.4.3.
- Remove top and bottom finger plates: 7.4.4 and 7.4.5.
- **Removal**
 - a. Invert the instrument.
 - b. *(Page 10.2-7, DA400786 Sh. 3, Detail 12)*
Remove the three M3 nuts and shakeproof washers which secure the input and output terminal support brackets to the Front Panel.
 - c. *(Pages 10.2-8 & 10.2-9, DA400786 Shts. 4 & 5)*
Disconnect the ribbon connector, soldered into J31, from the other end at J9 on the Sense PCB. Release the ribbon from its clips on the Sense PCB.
 - d. Reinvert the instrument to its upright position, taking care not to trap the ribbon cable.
 - e. *(Page 10.2-9, DA400786 Sh. 5)*
Release the cables, running along the top rear of the front panel, from their white nylon clip on the Front Panel PCB.
 - f. *(Page 10.2-9, DA400786 Sh. 5)*
Release and disconnect the following seven Molex PCB connector sockets from the Front Panel PCB : J25, J18, J17, J19, J2, J20 and J13. Ensure that they can be identified for correct refitting later. (The Molex connector at J30 for the Power Switch need not be removed.)
 - g. *(Page 10.2-7, DA400786 Sh. 3, Detail 11)*
Remove the four M3 x 8mm countersunk screws which secure the front panel to the side extrusions.
 - h. Carefully withdraw the Front Panel Assembly from the instrument (remember that the ribbon cable is still attached!).

- **Fitting**

Reverse the removal procedure, taking heed of the references at each stage. Locate the mains transformer stub into its hole on the PCB, and be careful not to trap any wiring. Make a final inspection to ensure that the ribbon cable and Molex sockets are correctly fitted and secured.

7.4.7 Air Intake Filter

- **Removal**
 - a. *(Page 10.2-15, DA400856)*
Remove the four M3 x 10mm screws and shakeproof washers which secure the Filter Support to the rear panel. Remove the support and filter.

- **Fitting**

Reverse the removal procedure.

7.4.8 Rear Panel Assembly

CAUTION:

For most purposes it should not be necessary to remove the Rear Panel Assembly. To do so will remove much of the mechanical support for the internal sub-assemblies. Great care must be taken to avoid leaving the sub-assemblies unsupported.

- Remove top and bottom covers: 7.4.1 and 7.4.2.
- Remove insulating pieces: 7.4.3.
- Remove top and bottom finger plates: 7.4.4 and 7.4.5.
- **Removal**
 - a. *(Pages 10.2-8 and 10.2-9, DA400786 Sheets 4 and 5)*
Disconnect the two Molex sockets from their plugs at J25 and J17 on the Front Panel PCB.
 - b. Invert the instrument.
 - c. Release the two cables disconnected in (a) from their retaining clips. Pull the socket ends clear of the instrument.
 - d. *(Page 10.2-8, DA400786 Sh. 4)*
Remove the M3 nut and shakeproof washer which secure the braid and three ground wires to the Rear Panel ground screw. Remove the leads from the screw, leaving the locknut and washer in place.
 - e. *(Page 10.2-7, DA400786 Sh. 3, Detail 9)*
Remove the two hexagonal 'D' lock screws securing J54 to the rear panel.
 - f. Reinvert the instrument to its upright position.
 - g. *(Page 10.2-15, DA400856)*
Analog Slave Input J66 internal cable: disconnect the Molex socket at J8 on the Sense PCB. Release the cable from its retaining clip and pull it clear of the instrument.
 - h. *(Page 10.2-15, DA400856)*
Remove the two M3 x 8mm screws and shakeproof washers which secure the Output PCB support bracket (Pt. No. 450705) to the rear panel.
 - j. *(Pages 10.2-5 and 10.2-7, DA400786 Sheets 1 and 3)*
Remove the two M3 x 8mm screws and shakeproof washers which secure the Main Support Bracket (Pt. No. 450684), to release the support from the rear panel. Ensure that the bracket is well supported from below.
 - k. *(Page 10.2-7, DA400786 Sh. 3, Detail 6)*
Remove the four M3 x 8mm countersunk screws which secure the rear panel to the side extrusions.
 - l. Carefully withdraw the Rear Panel Assembly from the instrument (remember that cables are still attached!).

- **Fitting**

Reverse the removal procedure, taking heed of the references at each stage. Be careful not to trap any wiring. Make a final inspection to ensure that the wiring and Molex sockets are correctly fitted and secured.

7.5 Sub-Assembly Removal and Fitting

7.5.1 Sense PCB

- Remove top and bottom covers: 7.4.1 and 7.4.2.
- Remove insulating pieces: 7.4.3.
- Remove Front Panel Assembly: 7.4.4.
- **Removal**
 - a. Stand the instrument in its normal upright position.
 - b. (Page 10.2-15, DA400856)
Analog Slave Input J66 internal cable: disconnect the Molex socket at J8 on the Sense PCB. Leave the cable in its clip, but pull the end clear of the Sense PCB.
 - c. (Pages 10.2-5 & 10.2-17, DA400786 Sh. 1 & DA400788 Sh. 1)
Disconnect the Fan Drive Molex connector (two leads) from J50 on the right side of the Sense PCB.
 - d. (Pages 10.2-8 & 10.2-17, DA400786 Sh. 4 & DA400788 Sh. 1)
Disconnect the SMPS PCB Molex connector (two cables) from J4 on the right side of the Sense PCB. (The Molex connector at J12 for the Output Relay need not be removed.)
 - e. Invert the instrument, taking care not to trap any cables.
 - f. (Page 10.2-8, DA400786 Sh. 4)
Disconnect the Output PCB ribbon connector from J22 on the Sense PCB. Pull the cable back to clear the Sense PCB.
 - g. (Pages 10.2-8 and 10.2-17, DA400786 Sh. 4 & DA400788 Sh. 1)
Disconnect the SMPS PCB Molex connector (two cables) from J4 on the right side of the Sense PCB.
 - h. (Page 10.2-7, DA400786 Sh. 3)
Remove the M3 nut and shakeproof washer which secure the braid and three ground wires to the Rear Panel ground screw. Remove the three leads from the screw, leaving the braid, locknut and washer in place. Release the Front Panel Input Ground lead from the clips on the Sense PCB, and pull it clear of the instrument.
 - j. (Page 10.2-8, DA400786 Sh. 4)
Disconnect the complete bus-bar set (part No. 450724): remove six M3 x 6mm screws and wavy washers on the Sense and Output PCBs; and three M3 x 16 screws, wavy washers and spacers on the SMPS PCB. Carefully detach the complete bus-bar set, ensuring that the strips and foam spacers are not bent or separated..
 - k. (Page 10.2-7, DA400786 Sh. 3, Detail 9)
Remove the two hexagonal 'D' lock screws securing J54 to the rear panel.
 - l. (Page 10.2-7, DA400786 Sh. 3, Detail 8)
Remove the six M3 x 6mm screws and wavy washers securing the Sense PCB to the side and center supports. Carefully ease the board forward to clear the lip of the Rear Panel. Lift it away from the instrument, complete with the Sense Resistor, Output Relay and Output Terminals secured to their bracket.

- **Fitting**

Reverse the removal procedure, paying due regard to the references at each stage. Be careful not to trap any wiring. Make a final inspection to ensure that the wiring, ribbon cables, bus-bar set and Molex sockets are correctly fitted and secured.

7.5.2 Output PCB

- Invert the instrument and remove the bottom cover: 7.4.2.
- Remove bottom and back insulating pieces: 7.4.3.
- **Removal**
 - a. (Page 10.2-8, DA400786 Sh. 4)
Disconnect the Output PCB ribbon connector from J22 on the Sense PCB.
 - b. (Page 10.2-8, DA400786 Sh. 4)
Disconnect the complete bus-bar set (part No. 450724): remove six M3 x 6mm screws and wavy washers on the Sense and Output PCBs; and three M3 x 16 screws, wavy washers and spacers on the SMPS PCB. Carefully detach the complete bus-bar set, ensuring that the strips and foam spacers are not bent or separated..
 - c. (Page 10.2-7, DA400786 Sh. 3, Detail 8)
Remove the four M3 x 6mm screws and wavy washers securing the Output PCB to the rear panel bracket and center supports. Carefully lift the front and ease the board forward to clear the contact plate and wiring at the rear. Lift it away from the instrument and remove.
- **Fitting**

Reverse the removal procedure, paying due regard to the references at each stage. Be careful not to trap any wiring. Make a final inspection to ensure that the wiring, ribbon cable and bus-bar set are correctly fitted and secured.

7.5.3 Front PCB

- Remove top and bottom covers: 7.4.1 and 7.4.2.
- Remove insulating pieces: 7.4.3.
- Remove top and bottom finger plates: 7.4.4 and 7.4.5.
- Remove Front Panel Assembly: 7.4.6.
- **Removal**
 - a. (Page 10.2-5, DA400786 Sh. 1)
Remove the six M3 x 6mm screws and wavy washers securing the Front PCB to the front panel. Lift it away from the panel, complete with the switches and LEDs (the foam gaskets adhere to the front panel only).
- **Fitting**

Reverse the removal procedure, being careful not to trap any wiring. Make a final inspection to ensure that the LEDs and switches are correctly oriented, and that the Power Switch Molex connector at J30 is correctly fitted and secured.

7.5 Sub-Assembly Removal and Fitting (Contd.)

7.5.4 SMPS Box

- Remove top and bottom covers: 7.4.1 and 7.4.2.
- Remove insulating pieces: 7.4.3.
- Remove top and bottom finger plates: 7.4.4 and 7.4.5.
- **Removal**
 - a. Stand the instrument in its normal upright position.
 - b. (Pages 10.2-9 & 10.2-25, DA400786 Sh. 5 & DA400792 Sh. 1)
Disconnect the SMPS Control Molex connector from J18 on the top right side of the Front Panel PCB (second Molex connector in from the right).
 - c. (Pages 10.2-8 and 10.2-17, DA400786 Sh. 4 & DA400788 Sh. 1)
Disconnect the SMPS PCB Molex connector (two cables) from J4 on the right side of the Sense PCB.
 - d. Invert the instrument, taking care not to trap any cables. Unclip the cables from the Front Panel PCB.
 - e. (Pages 10.2-9 & 10.2-25, DA400786 Sh. 5 & DA400792 Sh. 1)
Disconnect the SMPS Control Molex connector from J2 on the bottom left side of the Front Panel PCB (the Molex connector nearest the PCB edge next to the ribbon cable).
 - f. (Page 10.2-8, DA400786 Sh. 4)
Disconnect the three bus-bar strips from the SMPS terminals by removing three M3 x 16 screws, wavy washers and spacers on the SMPS PCB. Ensure that the strips and foam spacers are not bent or separated..
 - g. (Page 10.2-8, DA400786 Sh. 4)
Release the two power input cables from their clips on the bottom of the SMPS box, in preparation for removing the box.
 - h. (Page 10.2-7, DA400786 Sh. 3, Detail 16)
Support the SMPS box from below, and remove the five M3 x 6mm screws and shakeproof washers securing it to the side panel angle bracket and center supports. Carefully lift the instrument off the box, ensuring that the cables from the box do not snag on any parts of the instrument. Lift the instrument away from the box and remove.
- **Fitting**

Reverse the removal procedure, supporting the box from below, and being careful not to trap any wiring. Make a final inspection to ensure that the Molex connectors on the Sense and Front Panel PCBs, and the bus-bar strips, are correctly fitted and secured.

7.5.5 SMPS Main PCB

- Remove top and bottom covers: 7.4.1 and 7.4.2.
- Remove insulating pieces: 7.4.3.
- Remove top and bottom finger plates: 7.4.4 and 7.4.5.
- Remove SMPS Box: 7.5.4.
- **Removal**
 - a. (Page 10.2-6, DA400786 Sh. 2; Detail 11)
Remove the three M3 x 6mm screws and shakeproof washers securing the End Plate to the side and top of the screening box.
 - b. (Page 10.2-6, DA400786 Sh. 2; Details 10 and 9)
Remove the two countersunk screws securing the End Plate to the internal Control Screen on the SMPS Main PCB, and remove the End Plate with its gasket, lifting the cables and grommets out of the slots.
 - c. (Page 10.2-6, DA400786 Sh. 2; Details 8 and 7)
Remove the two M3 x 6mm screws securing the air scoop to the screening box, and remove the air scoop.
 - d. (Page 10.2-6, DA400786 Sh. 2; Details 6 and 5)
Remove the three M3 x 12mm screws and shakeproof washers securing the Heatsink, through the box, to the Heatsink Support Block of the SMPS Main PCB. Remove the Heatsink.
 - e. (Page 10.2-6, DA400786 Sh. 2; Detail 4)
Remove the seven countersunk screws securing the SMPS Main PCB to the screening box (five underneath the box, and two at the closed end).
 - f. (Page 10.2-6, DA400786 Sh. 2; Details 1, 2 and 3)
Carefully withdraw the SMPS Main Assembly, including the SMPS Control PCB and insulating sheet, from the box.
- **Fitting**

Reverse the removal procedure, being careful not to trap any wiring. Ensure that the Heatsink is correctly secured to the Heatsink Support block within the box. Make a final inspection to ensure that the connector cable grommets are correctly fitted in their slot in the end plate.

7.5.6 SMPS Control PCB

- Remove top and bottom covers: 7.4.1 and 7.4.2.
- Remove insulating pieces: 7.4.3.
- Remove SMPS Box: 7.5.4.
- Remove SMPS Main PCB Assembly from its Box: 7.5.5.
- **Removal**
- a. Ease the SMPS Control PCB away from the SMPS Main PCB until the two plugs and sockets (J/P1 and J/P28) have separated.
- b. Lift the Control PCB out of its end-slots and remove.

- **Fitting**

Reverse the removal procedure; do not press the PCB home until the plug/socket pins are correctly located in their slots.

7.5.7 Mains Transformer

- Remove top and bottom covers: 7.4.1 and 7.4.2.
- Remove insulating pieces: 7.4.3.
- Remove top and bottom finger plates: 7.4.4 and 7.4.5.
- Remove Front Panel Assembly: 7.4.6.
- **Removal**

N.B. Do not attempt to remove the transformer spindle from the center support, as the large screw which retains it is secured with 'Studlock'.

- a. *(Page 10.2-5, DA400786 Sh. 1)*
Remove the M6 Nylock nut and washer which secure the transformer to its spindle screw. Carefully withdraw the transformer, endplate and pad from the spindle; replace the endplate, pad, washer and locknut until ready to refit a transformer to the spindle.

- **Fitting**

Reverse the removal procedure, ensuring correct orientation of the transformer body.

7.5.8 Cooling Fan

- Remove top and bottom covers: 7.4.1 and 7.4.2.
- Remove insulating pieces: 7.4.3.
- Remove top and bottom finger plates: 7.4.4 and 7.4.5.
- Remove Front Panel Assembly: 7.4.6.
- **Removal**

- a. *(Page 10.2-5 & 10.2-17, DA400786 Sh. 1 & DA400788 Sh. 1)*
Disconnect the Fan Drive Molex connector (two leads) from J50 on the right side of the Sense PCB.
- b. *(Page 10.2-5, DA400786 Sh. 1)*
Remove the four M3 x 8mm screws and shakeproof washers securing the Fan to the center support. Lift the Fan and lead away from the instrument.

- **Fitting**

Reverse the removal procedure, ensuring correct orientation of the Fan body. Push the lead grommet into the slot in the center support.

SECTION 8 SERVICING AND INTERNAL ADJUSTMENTS

8.1 Introduction

This section provides procedures for maintenance operations which require removal of covers or partial dismantling.

The operations fall into three categories, as described in *Table 8.1* below.

Category A - Routine Servicing			
Servicing and Time Interval	Procedure Section 8	Calibration Required?	Calibration Procedure
Clean the Air Intake Filter 1 year (or less in adverse conditions)	8.2	No	—
Category B - Periodic Internal Adjustments			
PCB Assembly and Adjustment	Procedure Section 8	Calibration Required?	Calibration Procedure
Sense PCB (at yearly intervals) Differential Amplifier Common Mode Null and DC Offset.	8.3	Yes	Adjust Autobias before Calibrating
Output Amplifier Autobias Level.	8.4	Yes	Section 5
Category C - Adjustment Following Replacement of PCBs			
Assy Replaced and Adjustment	Adjustment Procedure Section 8	Calibration Required?	Routine Recalibration Procedure
Sense PCB; Sense Resistor; Output Relay. Differential Amplifier Common Mode Null and DC Offset.	8.3	Yes	Autobias next
Output Amplifier Autobias Level.	8.4	Yes	Section 5
Output PCB Output Amplifier Autobias Level.	8.4	Yes	Section 5
SMPS Main PCB; SMPS Control PCB. Repair at Datron Service Center	8.5	Yes	Section 5
Front Panel PCB; Mains Transformer; Cooling Fan. —	—	Yes	Section 5

TABLE 8.1 CATEGORIES OF SERVICING AND INTERNAL ADJUSTMENTS.

8.1 Introduction (Contd.)

8.1.1 General Procedural Notes

- a. Set Power OFF before attempting to dismantle the instrument (for dismantling and reassembly instructions see *Section 7*).
- b. After servicing ensure that all connections have been made, and that Top and Bottom Insulating Pieces and Covers have been replaced. Leave assembled instrument powered-up for at least 1 hour before carrying out any adjustment.
- c. Although replacement assemblies are set up by the manufacturer, the internal adjustments in *Table 8.1* must be carried out to ensure correct operation. These adjustments need to be carried out when the assembly is in the user's instrument, in order to account for interaction between assemblies.

8.2 Cleaning the Air Intake Filter

(Datron Part No. 450643)

8.2.1 Servicing Frequency

The filter should be cleaned at intervals no greater than one year. In dusty conditions the frequency should be increased.

8.2.2 Removal

(Assembly Diagram DA 400856, page 10.2-15)

- a. Remove the four M3 x 10mm screws (Pt No 611006) and washers (Pt No 613005) which retain the filter grille (Part No. 450636).
- b. Remove the filter grille and reticulated foam filter.

8.2.3 Cleaning

- a. Wash the foam filter in a dilute solution of household detergent (hand hot).
Rinse thoroughly in clean hand-hot water and dry completely, without using excessive heat.
- b. Clean the grille and the grille holes in the rear panel (use a vacuum cleaner and soft brush).

8.2.4 Inspection

Examine the foam filter for wear, replacing if links are broken.

8.2.5 Reassembly

Place the filter in the grille housing and secure the grille to the rear panel using the screws removed in 8.2.2.

8.3 Differential Amplifier - Common Mode Null and DC Offset Adjustment

(Refer to page 10.1-8)

8.3.1 Preamble

The following three adjustments account for small variations which may have occurred due to ageing of components. They should only be necessary at yearly intervals, or after a different Sense PCB is fitted into the instrument. For these reasons both of the common mode adjustments are preceded by a check, which determines whether or not the adjustment is needed. The DC offset adjustment accounts for any changes resulting from the DC and LF common mode adjustment.

A routine calibration is required after the adjustments are completed.

8.3.3 Test Equipment Required

AC Reference Voltage Source; Oscilloscope and DVM.

8.3.4 Initial Conditions

Solo Mode

Remove Top Cover - 7.4.1; p7-3.

8.3.5 DC and LF CMRR

- a. Remove any input to the instrument and short INPUT Hi to INPUT Lo, using a shorting bar or the shortest possible lead.
- b. Connect an AC Reference Source of 10VRMS at 10Hz to the instrument as follows; do not switch the source on yet:
 - i. Source Lo to TP404 on the Sense PCB (between inductors L401 and L402, to the right of relay RL402 at the front of the PCB).
 - ii. Source Hi to the shorted INPUT terminals.
- c. Connect an oscilloscope via a 2.5kHz bandwidth limiter as follows:
 - i. Scope Lo to TP404.
 - ii. Scope Input to TP414 (to the rear left of Relay RL401 at the front of the PCB).
- d. Switch on the instrument and the AC source, and adjust the oscilloscope controls to obtain a measurable waveform. Ignoring any 50/60Hz line signal that may be present, check that the 10Hz waveform on the oscilloscope is less than 500 μ V peak-to-peak.

Ignore operations (e) to (m) if the 500 μ V check in operation (d) was successful.

Note: The term 'FSV' means 'Factory-Selected Value'.

An isolated soldering iron should be used.

- e. Note the peak-to-peak value of the scope waveform. SWITCH OFF the instrument. Carefully unsolder and remove FSV resistor R409; suck out the solder from the FSV terminals.
- f. Note the value of the removed resistor. Select a 1% metal film resistor of value one increment larger, and fit into the FSV terminals, but do not solder in. Switch the instrument on, allow to settle and note the peak-to-peak value of the scope waveform. SWITCH OFF the instrument and remove the resistor.

Carry out operation (g) only if the peak-to-peak reading in (f) was less than that in (e).

- g. Repeat operation (f) until the peak-to-peak reading has passed through a minimum value and started to rise again. Select the resistor which provided the minimum peak-to-peak reading and refit to the FSV terminals.

Carry out operations (h) and (j) only if the peak-to-peak reading in (f) was greater than that in (e).

- h. Note the value of the removed resistor. Select a 1% metal film resistor of value one increment smaller, and fit into the FSV terminals, but do not solder in. Switch the instrument on, allow to settle and note the peak-to-peak value of the scope waveform. SWITCH OFF the instrument and remove the resistor.
- j. Repeat operation (h) until the peak-to-peak reading has passed through a minimum value and started to rise again. Select the resistor which provided the minimum peak-to-peak reading and refit to R409 FSV terminals.
- k. Switch on the instrument and check that the 10Hz waveform on the oscilloscope is less than 500 μ V peak-to-peak. SWITCH OFF the instrument and remove the resistor.

Ignore operation (l) if the 500 μ V check in operation (k) was successful.

- l. Reselect values of resistor for R409 as described above, and recheck the peak-to-peak values until a minimum of less than 500 μ V is obtained. (If this cannot be achieved, a fault exists which must be corrected before proceeding.)
- m. Trim the leads of the successful resistor to size and carefully solder it into the FSV terminals. Allow to cool and switch on the instrument.
- n. Check that the 10Hz waveform on the oscilloscope is still less than 500 μ V peak-to-peak. Reduce the output of the AC reference source in 1V steps from 10VRMS to 1VRMS, checking at each step that the peak-to-peak waveform value is less than 1mV.
- p. SWITCH OFF the instrument, leaving the AC reference source and oscilloscope connected, and proceed to 8.3.6.

8.3.6 HF CMRR

- a. With AC Reference Source and Oscilloscope connected as for DC and LF CMRR adjustment (8.3.5 above), remove the 2.5kHz bandwidth limiter (or set the oscilloscope to full bandwidth).
- b. Adjust the output voltage and frequency of the AC Reference Source to 10VRMS at 5kHz.
- d. Switch on the instrument and the AC source, and adjust the oscilloscope controls to obtain a measurable waveform. Ignoring any 50/60Hz line signal that may be present, check that the 5kHz waveform on the oscilloscope is less than 5mV peak-to-peak.

Ignore operation (e) if the 5mV check in operation (d) was successful.

Note: An isolated screwdriver-type adjustment tool must be used. Even so, the presence of the tool in the slot will add some capacitance and the reading is likely to change when it is removed. The peak-to-peak readings are only valid with the tool removed. This adjustment therefore requires some delicacy.

- e. Using the adjustment tool, adjust C402 (see Fig. 8.1) for a minimum peak-to-peak value of the scope waveform. Check that this is less than 5mV. (If this cannot be achieved, a fault exists which must be corrected before proceeding.)
- f. Check that the 5kHz waveform on the oscilloscope is still less than 5mV peak-to-peak. Reduce the output of the AC reference source in 1V steps to 1VRMS, checking at each step that the peak-to-peak waveform value remains less than 5mV.
- g. Reset the AC reference source voltage to 10V. Reduce the frequency of the AC reference source in 100Hz steps to 10Hz, checking at each step that the peak-to-peak waveform value remains less than 5mV.
- h. Reset the AC reference source frequency to 5kHz. Then increase the frequency in 1kHz steps to 20kHz, checking at each step that the peak-to-peak waveform value remains less than 25mV.

8.3.7 DC Offset

- a. Disconnect the AC Reference Source and Oscilloscope. Leave the input short connected.
- b. Perform an 'Input Zero' on the DVM to be used (10 μ V, 100 μ V and 1mV Ranges). Connect the DVM, set to its 1mV range, as follows:
 - i. DVMLo to TP404 on the Sense PCB (between inductors L401 and L402, to the right of relay RL402 at the front of the PCB).
 - ii. DVMHi to TP414 (to the rear left of Relay RL401 at the front of the PCB).
- c. Adjust R411 (see Fig. 8.1) to give a DVM reading as close to zero as possible, and check that this is less than 5 μ V. (If this cannot be achieved, a fault exists which must be corrected before proceeding.)
- d. Disconnect and remove the DVM.

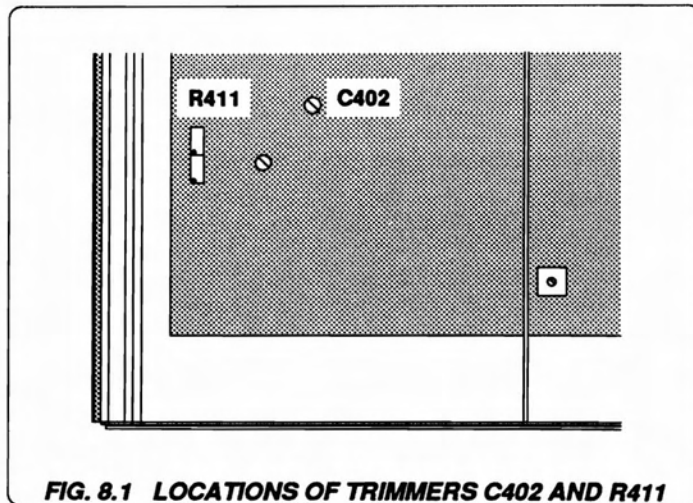

FIG. 8.1 LOCATIONS OF TRIMMERS C402 AND R411

8.3.8 Return to Use

Refit and secure the Top Cover - 7.4.1; p 7-3

A routine calibration is required after the adjustments are completed.

8.4 Output Amplifier Autobias Value Adjustment

(Refer to Section 10; pages 10.1-9 and 10.1-15)

8.4.1 Preamble

The following adjustment accounts for small variations which may have occurred due to ageing of components. They should be necessary only at yearly intervals, or after a different Sense PCB or Output PCB is fitted into the instrument. For these reasons the Autobias adjustment is preceded by a check, which determines whether or not the adjustment is needed. If the check discovers a large discrepancy in the standing Autobias current value, a further check is carried out to discover if this is due to a fault in one of the eighteen power transistors which drive the output.

A routine calibration is required after the adjustment is completed.

8.4.3 Test Equipment Required

10A DC Ammeter
Suitable DVM

8.4.4 Initial Conditions

Instrument Power Switch OFF.
Input disconnected from INPUT terminals.
External bus cables removed (for Solo mode).
Remove Top & Bottom Covers - 7.4.1/2; p7-3.
Remove the Bottom and Back Insulation Sheets - 7.4.3; p7-3
Place the instrument on its left side (ie. with the SMPS box uppermost).

8.4.5 10A DC Ammeter Connection

- Ensure that the Front Panel Power Switch is OFF.
- Looking from the front at the bottom of the instrument (now on the right side), identify the bus-bar screw at connection E26 on the Output PCB (see Fig. 8.1 and page 10.2-8).
- Release the E26 screw and gently lift the bus-bar so that it just clears its swage.
- Using crocodile clips on short leads (and thin insulating strips where necessary) connect the 10A DC Ammeter negative lead to the E26 swage only; then clip the positive lead to the other end of the bus-bar, close to the output screw at E241 on the SMPS. This places the ammeter directly in series with the +7.5V₂ supply line to the power transistors in the Output PCB.

8.4.6 Total Bias Current Measurement

- Set the Front Panel Power Switch to ON. The instrument powers up the SMPS by entering S2 state. This is shown by the ammeter reading increasing from zero as the class A bias current is established. Allow the reading to stabilize (approx. 20 seconds). Check that the reading lies between 8.5A and 9.5A.

Carry out the Current-Sharing check procedure 8.4.7 if the $\pm 0.5A$ check in operation (a) was unsuccessful.

- Check that the reading lies between 8.82A and 9.18A.

Carry out the Total Bias Adjustment procedure 8.4.8 if the $\pm 0.18A$ check in operation (b) was unsuccessful.

- SWITCH OFF the instrument, and disconnect the ammeter. Replace and secure the bus-bar screw at E26 on the Output PCB.

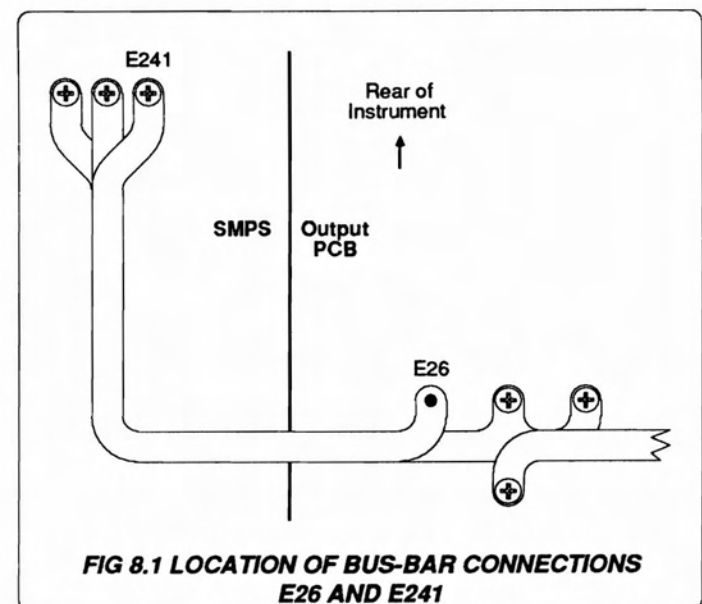

8.4.7 Current-Sharing Check

(Only to be carried out if the Total Bias Current Measurement Procedure 8.4.6 Operation {a} was unsuccessful)

- a. SWITCH OFF the instrument, and disconnect the ammeter. Replace and secure the bus-bar screw at E26 on the Output PCB.
- b. Place the instrument upside-down on the bench. Identify the connections to the power transistors Q120, Q121, Q122; Q124, Q125, Q126; Q128, Q129, Q130 on the Output PCB. The emitters are the square pads on the solder side of the PCB; these are positioned at intervals along the right side of the line of the heatsink, with Q130 at the front.
- c. SWITCH ON the instrument and allow it to settle for approx. 20 seconds. Set a DVM to its 100mV range and connect its Lo input to the emitter of Q130. Use the Hi input to probe the emitters of each of the other transistors listed in operation (b) in turn, noting the DVM reading for each emitter.
- d. Identify the emitters of the power transistors Q108, Q109, Q110; Q112, Q113, Q114; Q116, Q117, Q118 (also square pads). They are positioned along the left side of the line of the heatsink, with Q118 at the front.
- e. Set the DVM to its 100mV range and connect its Lo input to the emitter of Q118. Use the Hi input to probe the emitters of each of the other transistors listed in operation (d) in turn, noting the DVM reading for each emitter.
- f. Disconnect the DVM. The readings obtained in operations (c) and (e) should be between -50mV and +50mV. If any reading is outside this value, a faulty component (most likely the transistor) may be causing the deviation. A reading of volts, rather than millivolts, could represent a catastrophic failure.
- g. SWITCH OFF the instrument. After correcting any indicated faults, reconnect the ammeter as in procedure 8.4.5, and use procedure 8.4.6 to check the total bias current again.

8.4.8 Total Bias Current Adjustment

(Only to be carried out if the Total Bias Current Measurement Procedure 8.4.6 Operation {b} only was unsuccessful)

- a. Note the ammeter reading. SWITCH OFF the instrument. Identify FSV resistor R313 at the center front of the Sense PCB, to the rear of the test link TL402 between U310 and U405. Carefully unsolder and remove R313; suck out the solder from the FSV terminals.

Adjustment for Low Current

Carry out operations (b) to (f) only if the ammeter reading noted in (a) was less than 8.82A.

- b. Note the value of the removed resistor. Select a 1% metal film resistor of value one increment larger; fit into the FSV terminals, but do not solder in. Switch the instrument on, allow to settle and note the ammeter reading. SWITCH OFF the instrument and remove the resistor.
- c. Keep repeating operation (b), increasing the value of R313, until the first ammeter reading above 9.1A is reached. Select the resistor which provided the closest approach to 9.1A, and refit it to R313 FSV terminals.
- d. Switch on the instrument and check that the ammeter reading is between 9.00A and 9.18A. SWITCH OFF the instrument and remove the resistor.
- e. Trim the leads of the successful resistor to size and carefully solder it into the FSV terminals. Allow to cool and switch on the instrument.
- f. Check that the ammeter reading remains between 9.00A and 9.18A.

Adjustment for High Current

Carry out operations (g) to (l) only if the ammeter reading in (a) was greater than 9.18A.

- g. Note the value of the removed resistor. Select a 1% metal film resistor of value one increment smaller; fit into the FSV terminals, but do not solder in. Switch the instrument on, allow to settle and note the ammeter reading. SWITCH OFF the instrument and remove the resistor.
- h. Keep repeating operation (g) reducing the value of R313 until the first ammeter reading below 8.9A is reached. Select the resistor which provided the closest approach to 8.9A and refit it to R313 FSV terminals.
- j. Switch on the instrument and check that the ammeter reading is between 8.82A and 9.00A. SWITCH OFF the instrument and remove the resistor.

Final Check and Recovery

- k. Trim the leads of the successful resistor to size and carefully solder it into the FSV terminals. Allow to cool and switch on the instrument.
- l. Check that the ammeter reading remains between 8.82A and 9.00A.
- m. SWITCH OFF the instrument, and disconnect the ammeter. Replace and secure the bus-bar screw at E26 on the Output PCB.

8.4.7 Return to Use

Refit the Bottom and Back Insulation Sheets - 7.4.3; p7-3
Refit Top & Bottom Covers - 7.4.1/2; p7-3.

8.5 SMPS Tuned Circuit - Faults and Optimization

Two variable resistors on the SMPS Control PCB adjust the pulsewidth and maximum frequency of the signals which drive the tuned circuit on the SMPS Main PCB. These controls are interactive and the tuning operation is delicate. Access to detect the results of tuning entails removal of the PCBs from the screening box and application of power and signals by reconnection to the instrument. This leads to a potentially dangerous situation, because of the presence of high AC and DC voltages on the SMPS Main PCB.

User fault diagnosis might lead to the conclusion that a component or components within the box is defective. In this case, to safeguard personnel and equipment, contact the nearest Datron service center. The box may be removed from the instrument as described on page 7-6, but **DO NOT DISMANTLE THE BOX**. Further investigation will be carried out by the service center.

Before removing the box from the instrument, read the following warnings:

WARNINGS:

1. **DO NOT** attempt to adjust the drive signals to the tuned circuit.
2. **SWITCH OFF** the instrument before removing the box.
3. **DO NOT DISMANTLE THE BOX**

SECTION 9 TECHNICAL DESCRIPTIONS

9.1 PRINCIPLES OF OPERATION

9.1.1 Introduction

Functional Diagram

Fig. 9.1.1.1 illustrates the basic principles of the 4600.

Instrument Description and Slaving Options

The 4600 Autocal Transconductance Amplifier is an accurate DC or Sinewave AC current source, whose output amplitude (and frequency for AC) are determined by user inputs (within the specifications detailed in Section 4). In 'Solo' mode, it takes its AC or DC reference voltage input from any suitable source. In 'Slave' mode, it increases the DC and AC current outputs ranges of the 4700 compatible series of calibrators, up to a maximum of 11 Amps (DC or RMS AC). For Slave operation, the option requirements for the models in the range are as follows:

4700	Option 20
4705	Option 20
4708	DC Current: Options 10 and 30.
	AC Current: Options 20 and 30.
	DC and AC Current: Options 10, 20 and 30.

For all models, the firmware must be at issue 5 or later.

9.1.2 General Description

(Refer to Fig. 9.1.1.1)

Transfer Functions

As a 'Black Box', the 4600 defines a transfer function which is a linear 'Transconductance'. Between DC input voltage limits of +11V and -11V, the output is a current whose value lies between +11A and -11A and is defined by the linear equation: $I_{out} = V_{in} \times 1A/V$.

For AC voltage inputs, the same equation operates, generating output currents between 0.9A RMS and 11A RMS corresponding to input voltages between 0.9V RMS and 11V RMS, at frequencies between 10Hz and 20kHz.

All outputs are subject to the specifications given in Section 4.

Forward Amplification

A DC or AC voltage is delivered to the input of a non-inverting Differential Amplifier, which acts as a fixed-gain buffer to maximize common-mode rejection. Its conditioned output voltage is input to a 'Sense Amplifier', which drives a power amplifier capable of delivering the full range of output currents.

Sensing the Output

All the load current is passed through an internal series resistor. This provides a sense voltage which feeds back negatively as the other input to the Sense Amplifier, thus controlling the overall transconductance.

Digital Control

In Slave mode, a digital interface transfers control information from the slaving 4700-series calibrator to command the 4600, and retrieves status data. Solo mode is controlled by internal digital circuits.

For both modes, the Switch Mode Power Supply and Output On/Off switching are subjected to digitally-controlled sequencing to maintain safety, and protect the internal analog circuitry.

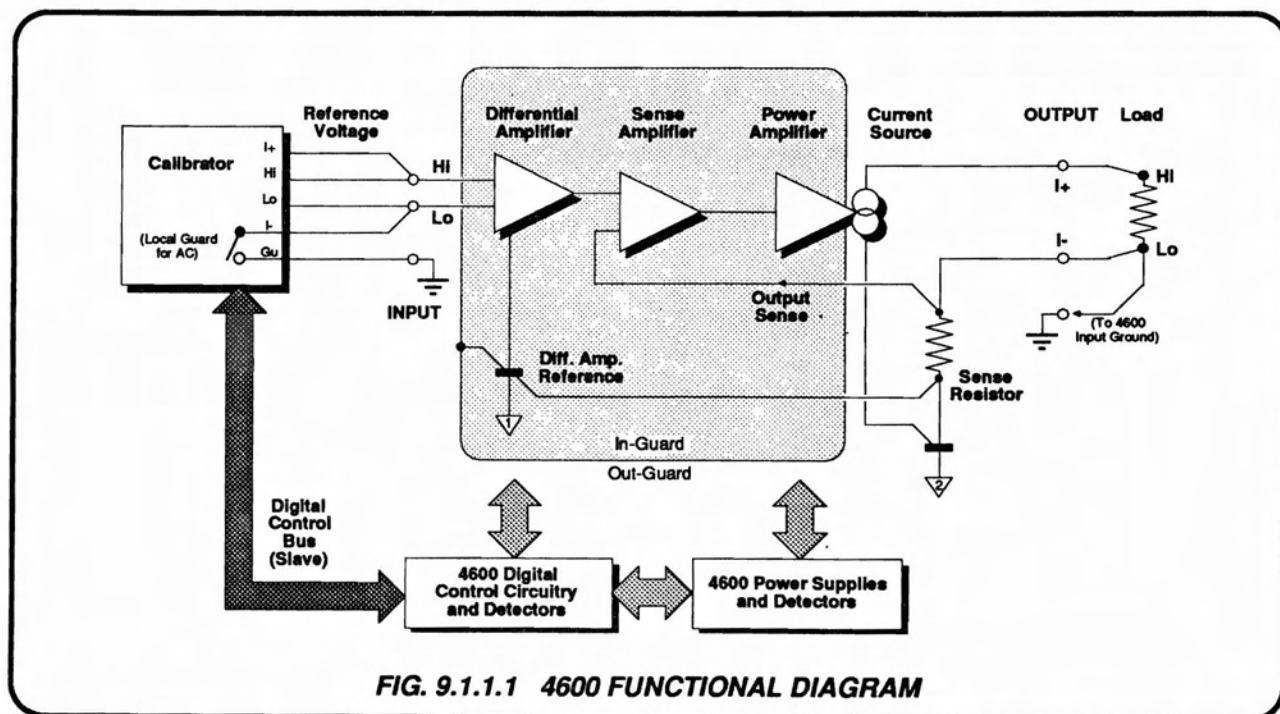

FIG. 9.1.1.1 4600 FUNCTIONAL DIAGRAM

9.1.3 Circuit Descriptions in Section 9

Section Divisions

This Section describes the operation of the circuits incorporated into the 4600. The object is to provide back-up information for those who are engaged in fault diagnosis on the instrument.

The description is split into four main divisions:

9.2 Analog Circuits:

This describes the main operational circuits which are directly concerned with generating the analog output of the instrument.

9.3 SMPS:

The Switch Mode Power Supply is permanently operative in Solo mode, but is turned on in Slave mode only when the 10A range is selected on the slaving 4700-series calibrator. It is the main supply for the analog output, and so is treated separately from the other power supplies in the instrument.

9.4 Digital Circuits:

Because the 4600 can be operated either in Slave or Solo mode, there is a basic need to transfer it from one mode to the other. When outputting its rated maximum current of 11A (DC or RMS), safety must be paramount when turning the output on and off. These two requirements have led to the design of automatic digital systems, which place minimal onus on the user, to perform the transfer and protect the circuitry. These systems are described in some detail within this sub-section.

9.5 Power Supplies:

This deals with both inguard and outguard supplies and their distribution, but not the SMPS.

9.2 ANALOG CIRCUITRY

9.2.1 Introduction

The circuits described in this section perform the following functions:

Differential Amplifier:

Buffers the Input Reference Voltage, maximizing common-mode rejection.

Sense Amplifier:

Senses the current output as the voltage across the internal series Sense Resistor, which carries the full output current. It uses the sensed voltage to determine the amount of drive to the Power Amplifier.

Power Amplifier:

Converts the drive from the Sense Amplifier into a current in the range -11A to +11A DC or RMS AC. This current is passed out of the Front Panel OUTPUT I+ terminal, and is returned to the internal Output Common 0V_2 through the internal series 'Sense' resistor via the OUTPUT I- terminal.

The Differential and Sense Amplifiers are located on the Sense PCB, the Power Amplifier occupies the Output PCB, and the Sense resistor is mounted separately within the instrument.

Fig. 9.2.1.1 illustrates the analog techniques by which the 4600 converts its Reference Voltage input into a defined current output.

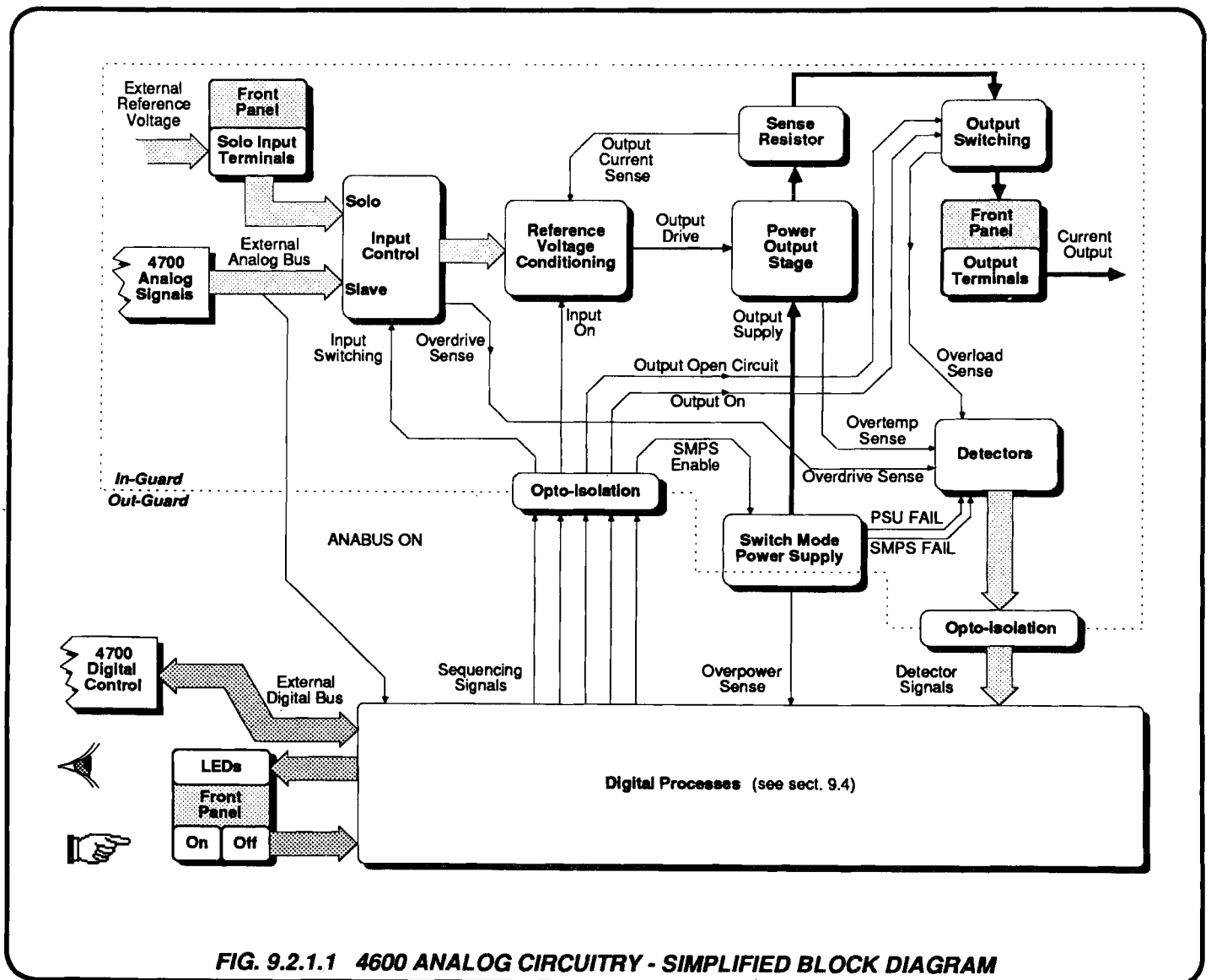

9.2.2 Slave and Solo Modes

(Circuit Diagram DC400786 Sheet 1, page 10.1-2 and Circuit Diagram DC400788 Sheet 4, page 10.1-11)

Solo/Slave Mode - Analog Differences

In the action of the analog circuits, the only differences between the two operating modes is that the input reference voltage enters at different terminals, and in Solo mode the manual zero and gain adjustment circuits are connected.

Solo Mode Input Connection

The DC Calibrator output voltage is applied to the two front panel INPUT terminals in Solo mode. Two-wire connection can be used, but the voltage arriving at the 4600 input terminals will be affected by the resistance of the connector leads, so it is preferred to use 4-wire connection to sense the reference voltage at the 4600 input terminals.

The input voltage is transferred internally from the front panel terminals as Hi_FR and Lo_FR, via pins E15-1/2 to the Sense PCB at J10-1/3.

The Input Ground terminal is connected directly to the internal case ground, and thence to the local line ground.

Slave Mode Input Connection

The Slaving 4700 output voltage is applied via the rear panel analog bus connector in Slave mode. Four-wire connection is used to deliver the reference voltage directly to the Differential Amplifier input switch, so that the 4700 senses its output voltage on the 4600 Sense PCB.

The input voltage is transferred internally from the rear Analog Socket J66 as Hi_R, Lo_R, I+_R and I-_R, to the Sense PCB at J8-1/2/3/4 respectively.

The Analog Socket Guard connection is passed into the Sense PCB as GU_R at J8-5, across the internal Guard barrier, and via E401 as EARTHST to the outguard local line ground.

Slave/Solo Mode Input Switching

(Circuit Diagram DC400788 Sheets 2 & 4, pages 10.1-7 & 10.1-11)
Section 9.4 (Digital Circuits) describes the Slave/Solo mode states. As far as the analog circuits are concerned, the mode changeover is effected by the state of the signal SOLO_H, received in-guard from opto-coupler U212 at pin 8. When SOLO_H is true (high), it is inverted by the relay driver at U401-15, and so selects Solo mode by energizing relays RL401 and RL402. When SOLO_H is false (LOW) the relays are unenergized, selecting Slave mode.

Four-pole relay RL402 performs the input changeover switching. In Solo mode only; relay RL401 connects the slider of Differential Amplifier zero offset potentiometer R411 to +15V_1B, and introduces a manual gain control circuit in parallel with the input resistor of the Main Attenuator connected across the Diff. Amp. output.

9.2.3 Reference Voltage Conditioning

(Circuit Diagram DC400788 Sheet 4, page 10.1-11)

Differential Amplifier

U402 is connected as a non-inverting, differential-input buffer, both sets of input resistors being equal to provide high common-mode rejection. Its gain is controlled by feedback resistors R413/R414 to the inverting input, and an attenuator on the non-inverting input (R408/R409 to mecca 0V_1) provides fine gain setting during manufacture. The gain is frequency-compensated for AC operation by C403 and C404, and across the input attenuator by trimmer C402 and padder C425. Overall gain of the stage is approximately 0.7. Diodes D401 and D402 protect against inadvertent application of excessive input voltages.

Main Voltage Attenuator

R415 and R436 forms the main voltage attenuator, connected between the Diff. Amp. and the Sense Amp. In Solo mode its attenuation is also affected by the trimpot R417 (padded by R416) in parallel with R415. R417 is manually set during calibration of Solo mode, to adjust the 4600 DC gain; R416 is normally only selected at manufacture. C424 is provided to allow the AC frequency response in Solo mode to be manually calibrated, its range of adjustment being set by C406.

Sense Amplifier

The non-inverting input to The Sense Amplifier is derived from the input reference voltage, and the inverting input is the Sense voltage (developed across the Sense resistor which is connected in series with the total output current). So the Sense Amplifier as a whole acts as an error amplifier, whose output is proportional to the difference between the two inputs. Its output is fed as a current 'I_DRIVE' to a buffer stage on the Output PCB.

The Sense preamplifier U403/U404 is a low-noise compound AC/DC circuit. DC components of the input signal from the Main Attenuator are amplified in U403, and then applied as offset null control to U404-8 via attenuator R423/R422. Capacitor C411 controls U403 frequency response.

Because the Power Amplifier has to be able to feed into inductive loads, it is necessary to ensure that non-linearities in the Sense/Power Amplifier loop response do not cause oscillations over a range of output load, amplitude and frequency conditions. The design of the cascaded integrator U404/U405 sets the dominant pole of the response to achieve this flexibility.

U405 uses the full $\pm 15V_{1A}$ supply to linearize its output swings, whereas U403 and U404 supplies are further regulated by D403 and D404 to approx. $\pm 6.8V$ to achieve low preamp. noise levels.

The Sense Amplifier output is passed out of the Sense PCB at J22-6 as a current, to drive the Power Amplifier buffer on the Output PCB.

Input On/Off

During the Output On sequence for both Slave and Solo modes, the final operation is to permit the input reference voltage to control the output in state R5 or S5. This is done by releasing two FET short-circuits in the Main Attenuator. During Output Off, the shorts are reimposed when transferring from R5 to R4, or from S5 to S4. The signal IPON_H is used to accomplish the changes; it is passed into guard via optocoupler U214 at U214-8 (refer to Section 9.4).

When IPON_H is true (high) in state R5 or S5, MOSFET Q402 conducts, pulling the gates of FETs Q401 and Q403 down below conduction threshold. The FET source-drains become open-circuit, removing the attenuator shorts. In all other states IPON_H is false (low), Q402 is cut off, and the FET gates are released to acquire Common 0V_1 potential. This allows the source-drains to conduct, short circuiting both ends of R444 to common 0V_1 and removing the voltage input to the Sense Amplifier.

Test Links

The test links TL401 and TL402 are provided so that the Sense Amplifier can be tested in a negative feedback loop of its own, isolated from the Power Amplifier and Sense Resistor. This is mainly for use during manufacture, or when a fault is suspected on the Sense PCB.

9.2.4 Current Amplification

(Circuit Diagram DC400789, page 10.1-15)

Buffer

M101 is connected as a non-inverting, unity-gain, differential-input buffer. The output current from the Sense amplifier is driven via J21-6, R101 and R105 into Common 0V_2, which is the output current sink. The output current at M101-6 is driven via R107 and R102 back into Common 0V_1, which is the Input Reference Voltage and Sense Voltage common. Thus the differential input to M101 is referred to both commons, in a sense which rejects common-mode disturbances between the two.

The buffer output eventually drives the two complementary sets of three Darlington output stages, but it first needs to be inverted and level-shifted.

Inversion and Level-Shifting

The complementary inverters Q103 and Q104 are parallel fed from the buffer output. This eventually causes the Darlington to give a push-pull drive to their heatsink output. As the two transistors are in common-emitter mode, their collector outputs are inverted.

The two inverters are biased to establish the correct class A conditions for the Darlington. Q101 provides a 2.4mA constant current drive to the bias circuit, to shift the levels of the split buffer outputs to the potentials required for the inverters. These potentials also need to compensate for variations of the mean Darlington current, so the negative end of the bias chain is taken to the output of an 'Autobias' generator, which senses each of the Darlington emitter currents, and carries out the averaging process.

Emitter-followers Q102 and Q105 buffer the outputs from the inverters before driving the Darlington.

Autobias

The output Darlington operate in class A push-pull, to eliminate the crossover distortion in the output which would be associated with class B or C operation. In class A, even with no input, a standing bias current is established through each of the 18 Darlington transistors, whose collectors are thermally attached to the heatsink. Variations of heatsink temperature can occur (particularly for a few minutes after a cold start-up), and unless compensation is applied, these variations, or component ageing, could cause the standing bias current to drift.

To reduce the drift to a manageable level, any compensation must detect variations in the total current affected by the heatsink temperature, and provide a bias which restores it to its correct value. Fortunately in class A, any current taken off as output increases the current in one side of the push-pull output by an amount equal to the decrease it causes in the other side. So the total current affected by the heatsink temperature remains the sum of all the individual transistor currents, and can be represented by their mean value; regardless of the value of output current.

In the 4600, the compensation is applied as a form of 'Autobias', which detects the emitter current in each of the output transistors, calculates the mean value to determine the amount of bias to be generated, and then superimposes that bias on the drive voltages to the two inverters Q103 and Q104. The necessary processing is done on the Sense PCB, using analog techniques (Circuit Diagram DC400788 Sheet 3, page 10.1-9).

Autobias Generation

Each of the nine positive-side Darlington output transistors has its output current sensed separately, by a low-value resistor placed in series with its emitter. The nine voltages across the resistors are summed at a star-point to form the +SENSE signal. Similarly the negative-side star-point is the SENSE- signal. These two signals (together with their associated SMPS $\pm 7.5V$ supply line potentials) are passed to the Sense PCB via J21 and J22 to drive the Autobias Generator. The bias supply, ($\pm 15V_{OP}$ on Common 0V_2) is also passed to the Sense PCB to power the circuit.

Thus the Autobias Generator has two inputs:

- The +SENSE signal referred to the SMPS +7.5V supply-line potential, applied to the inverting input U308-2;
- The -SENSE signal referred to the SMPS -7.5V supply-line potential, applied to the non-inverting input U308-5.

Both halves of U308 are connected as differential amplifiers to reject the $\pm 7.5V$ common-mode components of the inputs. The two outputs are summed into the inverting input of Error Amplifier U310, to be compared against a reference voltage produced at the junction of R313 and R314. U310 is connected as an integrator to match the slow slew rates of thermally-dependent variations, and not be affected by any AC components of signals in the Output Amplifier. The output current from U310 drives the base of current-mirror Q316, whose collector draws current through the Output Amplifier 'AUTOBIAS' line.

Variations in the mean of the emitter currents of the Power Transistors in the Output Amplifier will thus cause variations in the current in the AUTOBIAS line at J21-13 (Circuit Diagram DC400789, page 10.1-15). To show that the action gives the required compensation we need to trace the sense of the autobias signals from cause to effect.

Autobias Sense

Consider the case of the heatsink warming from a cold startup. Intrinsic conduction in all the power transistors will increase due to the temperature rise, so the compensation should be applied in such a sense as to oppose the increase.

For an increased conduction, emitter currents will also increase and the summed +SENSE signal will be driven more negative with respect to the +7.5V supply line; similarly the -SENSE signal will be driven more positive with respect to the -7.5V line.

These changes are transferred to the Sense PCB, affecting the input differential amplifiers. Because of their input connections, both output voltages from U308 at TP507 and TP508 will rise positive, causing the summing point at TP509 (Q310-2) to follow. The voltage at this point will rise more positive than the 0.4V at the reference input to U310-3. Thus the output voltage at U310-6 will ramp negative due to the positive input and the integrator action. Less current will be driven into current-mirror Q316 base, so its collector current will draw less through the AUTOBIAS line in the Output Amplifier.

On the Output PCB, Q101 sources a constant 2.4mA into the AUTOBIAS line. Because the current mirror collector is drawing less, the difference must be sunk into the buffer M101 negative supply, and M101-6 moves more positive. This will start the heatsink (output) voltage moving negatively, assisted by the greater positive movement at Q104 base. The main Output Sense loop responds by sending M101-6 more negative to absorb the diverted current, pulling the voltage at Q103 base down until the heatsink voltage is restored and both inverter bases have the same (but less) complementary bias.

With less bias on the inverter bases, the output transistor base currents are reduced on both positive and negative sides of the heatsink. As a result the standing currents in the output transistors (which had increased due to the temperature rise) are reduced, to restore the original values.

The same stabilizing effect is felt when changes occur due to ageing or power supply variations, or when ambient temperatures fluctuate. Because the response of the Autobias loop is slow, and the Autobias Generator's input amplifiers reject common-mode; and also because the buffer output M101-6 is AC-coupled to the inverter bases by C113 and C114; the autobias is as effective for AC outputs as it is for DC, limited only by the gain of the Autobias loop.

Current Output Stage

(Circuit Diagram DC400789, page 10.1-15)

All of the Darlington transistor collectors are electrically and thermally connected to the heatsink, including the six drivers. The stage therefore provides a single totem-pole current output via the heatsink to the I+ terminal, the current being returned via the I- terminal to Common 0V_2, with all contributing current sources operating in push-pull parallel. The stage is biased in class A to maintain a constant internal power dissipation via the heatsink, which is force-air cooled to stabilize the internal temperature. Use of class A conditions assists the effectiveness of the autobias in compensating for unavoidable temperature variations, as mentioned earlier.

Overtemperature Sensing

Thermistor R160 is thermally (but not electrically) connected to the heatsink to sense heatsink temperatures. R160's negative temperature coefficient of resistance determines the operation of the Overtemp LED and its associated detector circuit. This is described in *Section 9.4.5* on *Page 9.4-9*.

9.2.5 Current Output and Sensing

Current Output Routing

(Interconnection Diagram DC400786 Sheet 1, page 10.1-2)

The output current signal 'I+' travels from the heatsink out of the Output PCB via E102 to the Output Relay contacts, and from the closed contacts to the Front Panel OUTPUT I+ terminal as the 'I+_OUT' signal.

The current returns via the I- terminal, then as 'I-_OUT' to other Output Relay contacts, and from the closed contacts to terminal RH of the precision Sense Resistor. After passing through the sense resistor, the output current passes to the Output PCB to be sunk into the SMPS Common 0V_2.

Output Current Sensing

The Sense Resistor is 4-wire connected in the I- output current path and to the inverting input of the Sense Amplifier. The Sense connections go via E407 and E408 into the Sense PCB, where the SENSE_Hi voltage is applied to the inverting input of the Sense Amplifier to close the whole output negative feedback loop. The SENSE_Lo connection is taken to the voltage amplification mecca - Common 0V_1.

A simplified functional diagram of the loop and a description of its overall action is given in Section 1, on Page 1-3.

Internal Load

(Circuit Diagram DC400788 Sheet 4, page 10.1-11)

During the On/Off Sequence, an internal 18Ω load (R437 in the Sense PCB) is connected across the output relay contacts via J12-3/4 and Sense PCB relay RL403 contacts. This load is open-circuited by RL403 only in states R4 and R5 (Slave mode) or states S4 and S5 (Solo mode).

9.2.6 Output On/Off Sequence

The digital operation of the On/Off Sequence is described in Section 9.4.3 starting on Page 9.4-4. The aim of the sequence is to turn on the output safely, with detectors alert to potential faults.

Effect on Analog Circuits

The effect of the sequence on the analog circuitry is the same whether in Slave or Solo mode, and whether the output is being sequenced on or off:

State	SMPS	Output Relay Contacts	Internal Load	Input Reference Voltage
R1; S1:	disabled	open	connected	Off
R2; S2:	enabled	open	connected	Off
R3; S3:	enabled	closed	connected	Off
R4; S4:	enabled	closed	open circuit	Off
R5; S5:	enabled	closed	open circuit	On

Detector Activity

Because of the effects of the sequence, the analog fault detectors can be active in more than one state. For instance the overdrive detector can sense excessive input voltage in all states and light its warning LED. Analysis of the information provided by the Front panel LEDs or Slave mode messages is more relevant to fault diagnosis than to circuit description, and is therefore conducted in Section 6.

9.3 Switch Mode Power Supply

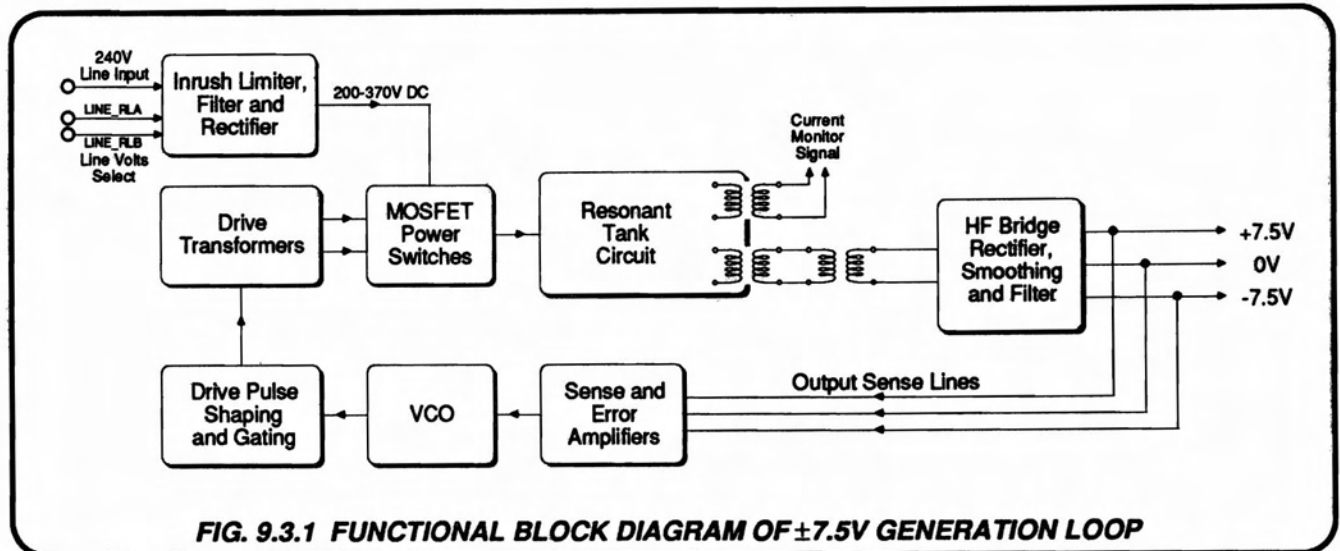

9.3.1 General

(Refer to Fig. 9.3.1)

Purpose

The SMPS provides the $\pm 7.5V$ power rails for the output amplifier. Since the amplifier operates in class A, the power requirement is constant at approximately 135 watts. A resonant switch topology is used to reduce conducted and radiated noise spikes. Noise radiation is further reduced by housing the SMPS in a welded aluminium enclosure.

Implementation

Two MOSFET switches, synchronized to the output of a VCO, drive a series-resonant LC tank circuit. The inductance of the tank is formed by the leakage inductance in the series primary windings of two separate transformers. A cascaded power transformer contributes the majority of the inductance, driving a bridge rectifier to provide the 7.5V rail supply; the other senses the power transformer primary current for monitoring purposes.

Control

The rail voltages are continuously sensed. Rail error voltages control the frequency of the VCO, which closes the loop by adjusting the frequency of the switching waveforms for the MOSFET switches. A reduced rail voltage increases the frequency of the VCO, which results in an increase of current into the tank circuit, raising and restoring the rail voltage.

Protection

Undervoltage, overvoltage and overpower detectors are also provided, to protect against catastrophic variations of the rail voltages or excess amplifier standing current.

9.3.2 $\pm 7.5V$ Generation Loop

(Circuit Diagram DC400790 Sh1 1 page 10.1-17)

Line Input

The switching stage is powered from a DC supply of between 210 and 370 volts which is derived from the power line. Rectifier D1 is configured automatically by a line voltage sensing circuit and relay located on the front PCB. It is connected either as a full-wave bridge (for 220V-240V AC operation), or as a half-wave voltage doubler by shorting the two lines LINE_RLA and LINE_RLB (for 100V-120V AC operation).

Line Voltage Detector

(Circuit Diagram DC400792, Page 10.1-21)

Because the SMPS is required to draw a heavy current from the line supply, it does not receive its power through the mains transformer, but takes it directly from the mains input module. The line voltage selector PCB on the Rear Panel of the instrument operates only in conjunction with the primaries of the mains transformer; so a separate, automatic means of detecting the voltage of the line input is used. This shorts the two lines LINE_RLA and LINE_RLB whenever the input voltage is less than 200V and removes the short for input voltages greater than 200V.

The detector is located on the Front Panel PCB and is powered from the +10V_RAW_OG supply (the rectified main digital supply, taken across the reservoir capacitor C104). MOSFET Q101 and relay RL101 are powered from the Front Panel FP_+5V supply.

After being switched by the Front Panel Power switch, the line input splits into two paths: P_LIVE and P_NEUT driving the Mains Transformer; MAINS_L and MAINS_N being fed to the SMPS bridge rectifier (which is sensed by the detector).

The sensed voltage is applied across diode-resistor chain D101/D102/R101/D103, including the LED in opto-coupler U101. D102 is a 200V zener in reverse bias to positive half-cycles of line input.

During negative half-cycles both D102 and D103 are held in forward bias, so virtually all the input voltage is developed across D101 (R101 carrying only the D101 leakage current) and the U101 LED is cut off.

During positive half-cycles both D101 and the U101 LED are in forward bias and D103 is cut off. The LED current is controlled by the input voltage acting on the 200V zener D102, and R101. If the input voltage is less than 200V peak (e.g. 120V RMS peaks at around 170V), then the zener does not enter avalanche conditions and the LED current is below light threshold. The LED is only lit for instantaneous voltages just in excess of 200V (200V RMS peaks at about 280V), causing U101 transistor to conduct.

At power on, when the +10V supply voltage is rising, the time constant R102/C101 holds back any increase at Q101 gate for approximately half a second. During this time Q101 does not conduct and relay RL101 remains unenergized. Thus for a safety delay of half a second the SMPS rectifier is connected as a full wave bridge (>200V condition), not as a voltage doubler (<200V condition).

Once the delay is finished: if the line input voltage is in excess of 200V the LED is lit, U101 transistor conduction holds Q101 gate below threshold and RL101 remains unenergized; but if the input voltage is less than 200V the LED is not lit, Q101 conducts as C101 charges, and RL101 energizes to short LINE_RLA and LINE_RLB. Under the latter conditions the SMPS acts as a voltage doubler to establish the correct high-voltage supply to the SMPS resonant tank driver switches in response to the lower line input voltage.

At power off, diode D112 conducts to discharge C101 rapidly through the digital circuitry, restoring safety conditions as the line voltage subsides. So if power is immediately restored, the half second safety delay is reimposed.

Bridge Rectifier Circuitry

The output from the rectifier is smoothed by two series-connected reservoir capacitors C3 and C4. During the first second following Power-on, relay RL3 contact remains open. This allows the series resistor R1 to limit the C3/C4 charging current. The relay contact closes after 1 second, and remains closed to maintain high efficiency. Fuse F2 is a thermal fuse strapped to R1, which will blow if R1 temperature exceeds 150°C (e.g. if RL3 contact fails to close). A line input filter minimizes differential and common-mode noise being conducted back along the power cable.

Power Switches

The power switches are N-channel power MOSFETs Q1 and Q2, connected in series across the DC supply. They receive their input from the in-guard SMPS Control assembly via pulse transformers T1 and T2. The MOSFETs are switched on alternately for 2.5 μ s, each on-pulse being followed by an adjustable short period when both devices are turned off ('dead bands'). During the pulses they feed current in turn (alternating polarities) into the resonant tank circuit.

Ring on the gate drives is damped by R-C networks, and resistors R7 and R8 prevent local oscillation of the power MOSFETs Q1/Q2.

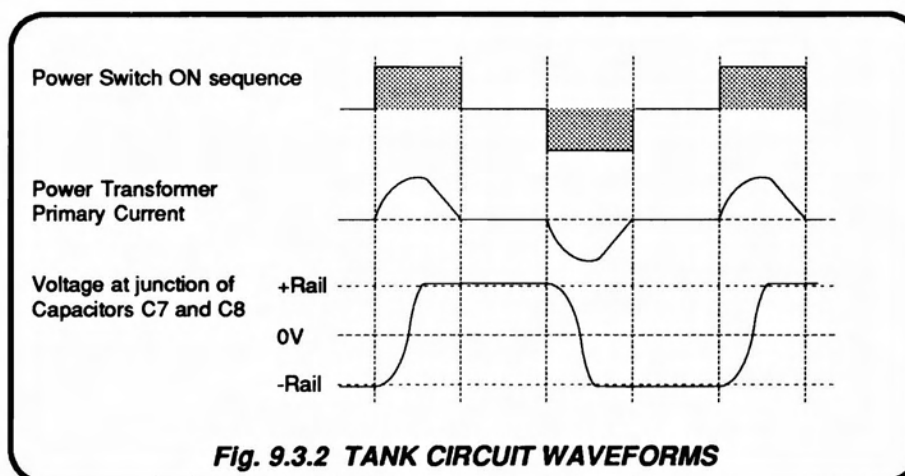

Fig. 9.3.2 TANK CIRCUIT WAVEFORMS

Resonant Tank Circuit

The tank is a series tuned circuit with a resonant frequency of approximately 200kHz, comprising C7 and C8 together with the leakage inductance of cascaded power transformers T4/5 (24 μ H). The 2.5 μ s current pulses, being applied via the center-node of the two MOSFETs, are forced to be sinusoidal; so a half-sine of current is produced in the power transformer primary for each pulse applied.

The magnitude of the primary current is determined by the magnitude of the supply voltage, the reflected transformer voltage, and the characteristic impedance of the resonant tank. Fast-recovery diodes D7 and D8 restrict the voltage across C7/C8 to be always within the supply rails of the switching stage.

When a switch is turned on, the charging current rise is held back by the leakage inductance, so the capacitor voltage (V_c) rises sinusoidally to cross the supply voltage level (V_{in}) just after $\pi/2$ of the resonant cycle ($\approx 1.3\mu$ s). As it continues towards its overshoot of $2V_{in}$, one of the damping diodes conducts at V_{in} + the diode drop and so V_c can increase no further. The leakage inductance field collapses, forcing current through the damping diode and transformer primary (to the load). The current falls linearly to reach zero at about the half-cycle point ($\approx 2.5\mu$ s), at which time the switch stops conducting, leaving the capacitor charged. Setting the ON times of the switches to 2.5 μ s (tuned to half a resonant cycle) ensures that the energy stored in the inductor field is close to its zero-crossing at the point of breaking the series connection.

The series resonant circuit cannot 'ring' during the dead band, as it requires at least one of the switching MOSFETs to be conducting to complete the series resonant circuit, and both are switched off during this period. The capacitor remains charged.

When the complementary switch is turned on, the current in the transformer is reversed, and the process is repeated to charge the other capacitor. By this means, alternate half-cycles of sinusoidal current are passed through the transformer primary, separated by short period of zero current. The two capacitors alternately charge and discharge, so that at their junction the voltage waveform is virtually trapezoidal.

Because the power switch ON times remain constant at 2.5 μ s, an increase in the frequency of the VCO is manifested as a reduced length of 'dead band'. The mean power in the tank is increased, resulting in an increased mean current in the power transformer primary and thus a higher DC voltage across the rail reservoir capacitors. Conversely, a reduction in VCO frequency reduces the voltage on the rails. Fig. 9.3.2 shows the transformer current and capacitor voltage waveforms.

Caution:

The voltage waveforms are included only to assist understanding of the tank action, and are in idealized form. Under no circumstances should an attempt be made to view the waveforms directly, as high 50/60Hz common-mode voltages are involved. In any case, probing this circuit will introduce distortion and radiation, so the results are not worth the danger and difficulty of measurement. The Current waveform in the tank circuit can be safely viewed at the secondary of transformer T3 (TP301 on the Sense PCB, or TP3 on the SMPS main PCB).

Power Transformers

T4 and T5 are cascaded to minimize electrostatic noise coupling to the in-guard 7.5V rails. To minimize common-mode transfer, the power is transferred across guard via low voltage, ground-related, balanced lines.

$\pm 7.5V$ Voltage Rails

The output from T5 secondary is bridge-rectified by high-frequency Schottky diodes D11-14, each diode having its own damping network. Six low-impedance electrolytic capacitors are used for bulk-smoothing on each of the supply rails, and further L-C filtering reduces output differential noise to the required level. Any common-mode HF noise on the output bus is filtered out by C32-34.

Voltage Regulation

The on-time of both MOSFETs is fixed at 2.5 μ s, but the dead time is varied automatically by adjustment of the switching frequency (and hence the switching mark/period ratio). Sensors on the 7.5V rails control the duration of the dead time using a negative feedback loop, and so regulate the rail voltage.

Current Monitor

Transformer T3 is present for two purposes:

- To provide a safe test point for viewing the tank circuit current waveform. TP3 (and TP 301 on the Sense PCB) are ground-related, so no large common-mode voltages occur at these test points.
- To sense the mean current in the tank circuit which, because the tank peak voltage remains constant, is a measure of the power provided by the $\pm 7.5V$ supply. The rectified and smoothed signal PWR_SIG is passed to the Sense PCB, where it is compared against a reference voltage to become the signal OVPWR_H (refer to Sub-section 9.4.5 on page 9.4.12; Circuit Diagram DC400788 sheet 3 - page 10.1-9).

9.3.3 $\pm 7.5V$ Control

(Circuit Diagram DC400791 Sheet 1 page 10.1-19)

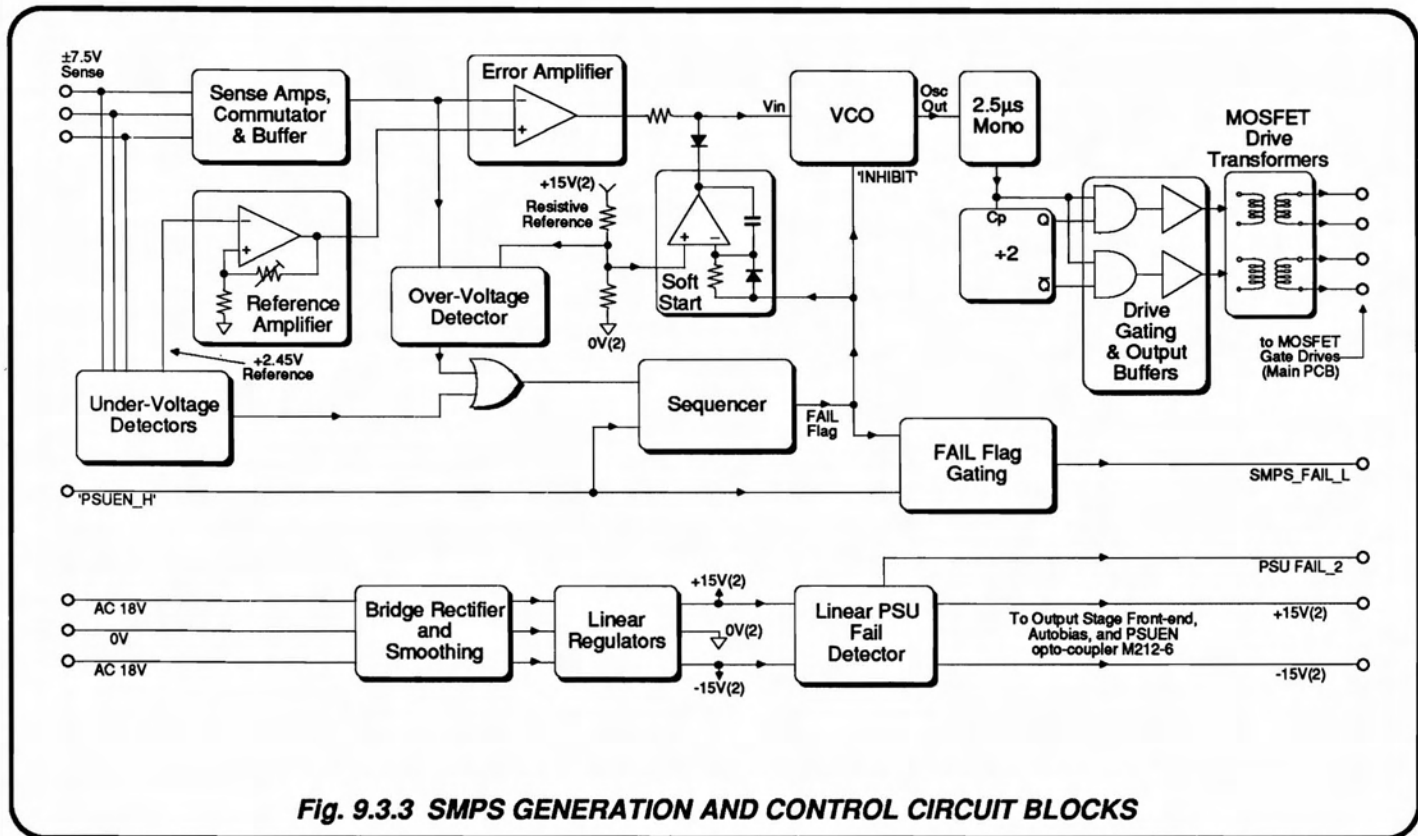

Fig. 9.3.3 SMPS GENERATION AND CONTROL CIRCUIT BLOCKS

$\pm 7.5V$ Rail Voltage Sensing

The sense amplifiers M1-7 and M1-1 provide inverting and non-inverting unity gain buffers for the balanced $\pm 7.5V$ rails. D1, D2 and R3 form a 'Sense Commutator', so that the Error Amplifier always senses only the rail whose voltage magnitude is the lesser. This method accounts for occasions when the rail loads are unbalanced (for instance when a DC Current is being output from the 4600), ensuring that the most-heavily loaded rail is the one which is actively regulated by the control loop.

Error Amplifier

The error amplifier is in two stages: M2-1 is a unity-gain buffer, while inverting amplifier M2-7 determines the control loop gain. D20 biases M2-5 and tracks the temperature coefficients of D1 and D2. The error amplifier output from M2-7 controls the frequency of the VCO in M3.

VCO

M3 is a PLL device used only for its VCO (the comparators are not connected). The VCO frequency end-stops are set by C3, R17, R18 and R19, and controlled between these limits by the error amplifier output into M3-9.

2.5µs Monostable, +2 Stage and Gating

The VCO output from M3-4 is passed to monostable M4(1-7) where the positive-going edge at M4-4 triggers a positive pulse at M4-6, whose pulse-width is set at 2.5µs by C6, R20 and R21. The monostable operates only when the PSUEN_H signal on M4-3 is active. The positive M4-6 pulses are applied to the four AND gates (M7).

M4-7 Q2_L output clocks a +2 bistable M10(8-13), which enables pairs of M7 gates in turn, steering the 2.5µs pulses from M4-6 alternately to the two power switch drivers. Thus the drivers are switched on and off in the following sequence: Q4/Q5 on; both off; Q6/Q7 on; both off; and so on. As all the 'on' times are fixed at 2.5µs, and as the VCO frequency is varied by the action of the error amplifier, so the effect of a change in the $\pm 7.5V$ rail voltage is to alter the duration of the 'both off' times in the sequence of driver conduction.

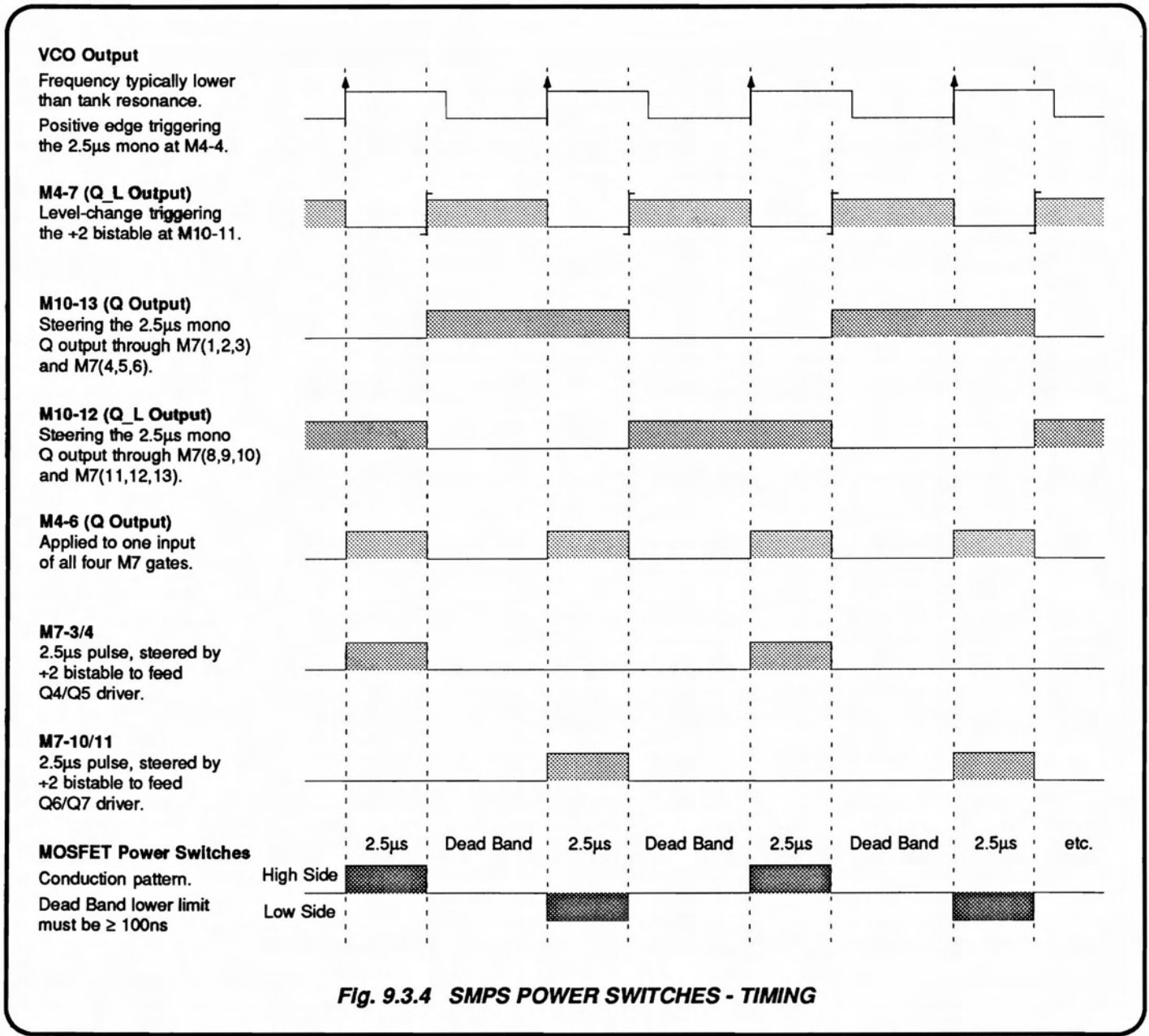

Power Switch Drivers

The outputs of the two gates in each pair are connected in parallel to provide sufficient current to drive the following totem-pole driver stage. Each driver is AC coupled to its output pulse transformer, the time constants being long enough to avoid serious distortion of the output pulses. Any ringing from the pulse transformer is limited to rail voltages by clamp diodes D4-D7. Both the drivers have identical action, and they are switched on alternately, interspersed by dead bands. Two MOSFET clamps (Q2 and Q3) are cross-connected from one driver to the other to ensure that the driver which is not switched on has no input. This prevents the catastrophe of both power switches in the SMPS Main PCB being turned on at a time.

Drive Output

The secondaries of the two pulse transformers are connected to two similar transformers on the SMPS Main PCB, whose primary center-taps are grounded. The windings of all four transformers are electrostatically screened to the same ground via the MAINS_E line, to minimize common-mode transfers. A series C-R filter is placed across the each of the primaries on the SMPS Main PCB to damp out any ringing in the cascaded transformers.

The subsequent drive to the main switching circuitry is described earlier under the heading of 'Power Switches'.

9.3.4 SMPS Control Sequencing

(Circuit Diagram DC400791 Sht 1 page 10.1-19)

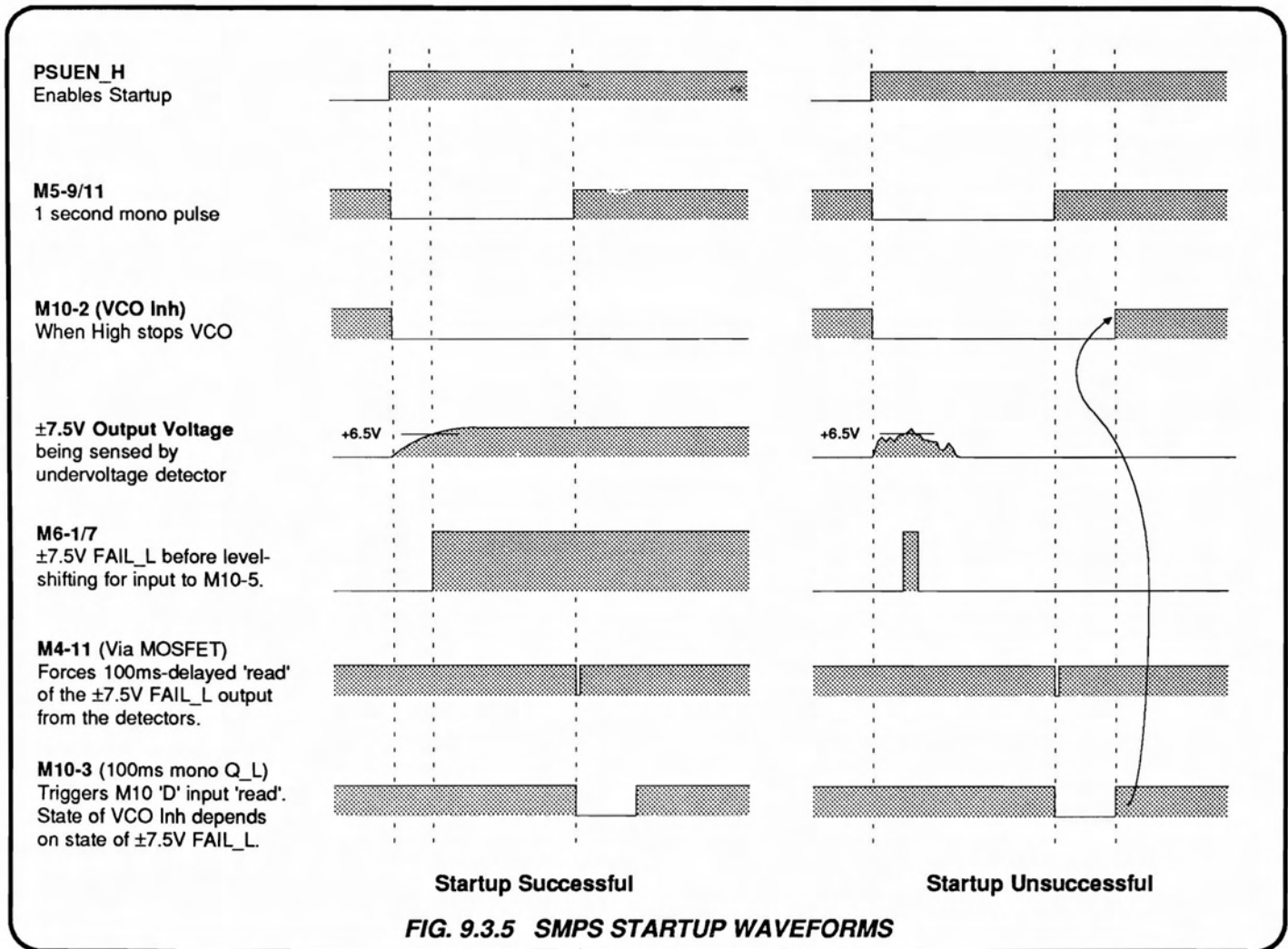

SMPS Startup Sequence

When the 4600 output is off, M10(1-6) is in reset. This holds the 'INHIBIT' input to M3 active at +15V, so the VCO is inoperative. Thus the power switches are both turned off, the power supply is not running and the 7.5V rails are at 0V. The 1-second monostable M5(8-14) is timed-out in reset state.

Some 500ms after the output is switched on (or the 4600 recovers from a fault) the PSUEN-H signal at P1-1 is taken from 0V to +15V, remaining active at +15V until either the output is switched off or a fault occurs. It is passed via a spike filter to M5-12, M5-5, M4-3 and R46. At M4-3, PSUEN_H high level enables the 2.5μs mono in preparation for the VCO clock pulses. It has no effect at M5-5, this is connected for the SMPS off sequence.

The rising edge of PSUEN_H at M5-12 generates a 1 second positive-going pulse at M5-10 (negative-going at M5-9) which sets M10(1-6). The 'Q_L' output at M10-2 falls to 0V, removing the inhibit from the M3 VCO, also setting the Soft-Start integrator (M2-14) on its ramp-up. The VCO starts to oscillate at a low frequency, so the 7.5V rails start at low voltage and ramp up as the VCO frequency is increased by the soft start ramp.

When M5-9 'Q_L' returns to high after its 1-second pulse, the rising edge couples through R39/C12 to the MOSFET switch Q8, turning it on briefly and clocking the monostable M4(9-15). Diode D11 prevents the negative backswing on the gate of Q8 coupling through the device capacitance and triggering M4 directly.

M4 output duration is ≈100ms, and when it times out the rising edge of its Q_L output (M4-9) is used to 'read' the D input of M10, which is the output from the over-undervoltage detectors. If all is well and the SMPS is running, then D will be high and the D-type will not change state, VCO Inh stays low and the SMPS continues to run. If D is low for any reason, the D-type will change state and inhibit the VCO.

If the detector outputs go low while the SMPS is running, M4 is clocked via C9/R33. Again the D input is read after M4 times out, and the SMPS will be shut down if D is still low. Because of the 100ms delay, the sequencer ignores any 'glitch' low outputs from the detectors whose duration is less than 100ms.

Diode D21, and resistors R49/R32 interface the ±15V swings of the detectors into the CMOS logic devices running from +15V/0V supplies.

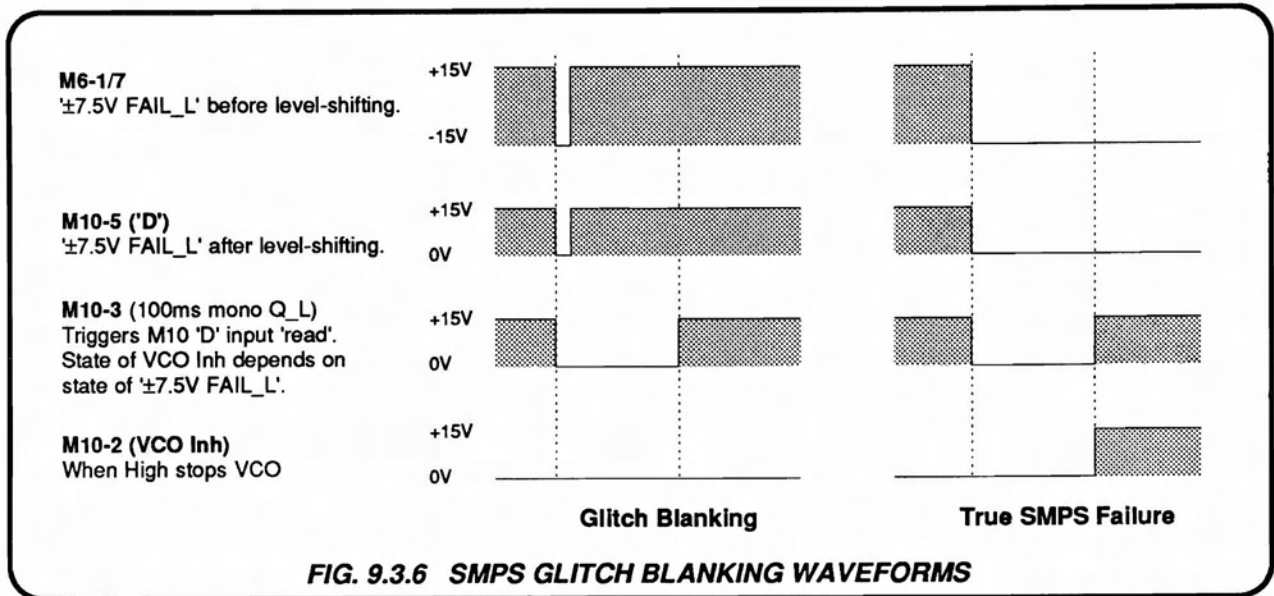

SMPS Off Sequence

When PSUEN_H is taken low to disable the SMPS, the falling edge triggers M5(1-7) at M5-5. A 10ms positive pulse is produced which resets M10(1-6), whose resulting positive 'Q_L' output is VCO Inh. This inhibits the VCO and the SMPS is disabled.

Undervoltage Detection

The Undervoltage Detector circuit is a standard window detector whose window is determined by twin bandgap references D8 and D9. Both 7.5V rail voltages are resistively divided (R23/R24 and R27/R28) to be compared against the 2.45V inputs to the two comparators. When both rail voltages are greater than 6.5V, the open-collector outputs of both comparators (M6-1/7) are held at +15V by R26. If one of the rail voltages falls below 6.5V, its comparator output pulls both M6-1 and M6-7 towards the -15V rail. This provides a negative-going trigger edge via C9 to the monostable M4(9-15) at M4-11, resulting in a 0V pulse at M4-9 which returns to +15V after 100ms.

After the 100ms delay, the rising edge of the M4-9 pulse clocks bistable M(1-6), and the comparator output low state (level-shifted by R49/R32 on to the 'D' input of the bistable) results in a positive 'Q_L' output at M10-2. This is 'VCO Inh' which causes the VCO oscillations to cease, disabling the SMPS. Because of the delay, the sequencer ignores any 'glitch' low outputs from the undervoltage detector whose duration is less than 100ms (see waveforms in Fig. 9.3.6).

The bistable 'Q' output at M10-1 changes to low, pulling Q10 emitter down with it. Because the signal PSUEN_H is still active-high, Q10 conducts to set the SMPS_FAIL_L signal to active-low.

Overvoltage Detection

The commutated output from the 7.5V Sense Amplifier has a second function - to drive the Overvoltage Detector (M1-9 via R50/C30). The detector is a high-gain inverting amplifier whose reference is set by divider R8/R9 at 10.2V.

Under normal operating conditions, this will always be greater than the input from the Sense Amplifier, so M1-8 is set close to the positive rail, keeping D10 cut off.

If the 7.5V rails rise to 11V (for instance by the control loop becoming open circuit), then after a delay of 2 seconds due to R50/C30, M1-8 changes polarity to the -15V rail. D10 conducts, pulling down the Undervoltage Detector output, and providing a negative trigger edge to M4-11. As a result of M1-8 being negative for more than 100ms, the SMPS is disabled and the SMPS_FAIL_L signal becomes active-low (as described above for undervoltage detection). Again, 'glitch' low outputs of less than 100ms from the overvoltage detector are ignored.

SMPS_FAIL_L

Q10 acts as a gate to activate the SMPS_FAIL_L signal only when the external PSUEN_H signal is active, and the SMPS has been internally disabled. Q10 collector is low only when M10-1 is low (signifying that the high at M10-2 has inhibited the VCO) and the divided PSUEN_H at Q10 base is high, causing collector conduction. The SMPS_FAIL_L signal therefore becomes active low only when the external state requires the SMPS to operate, but an internal cause is preventing it from doing so.

The SMPS_FAIL_L signal is passed via the SMPS Main PCB to the Sense PCB, where an internal LED (D326 - see Circuit Diagram DC400788 Sht 3, page 10.1-9) is lit when the signal is not active, but goes out when the signal is active low. It is ORed there with two other signals: the PSUFAIL_2 signal and the 15V_3 signal; to form PSUFL_H, which is passed out of guard to change the front panel 'Psu' LED from red to green for any one of the three original failures. In Slave mode, PSUFL_L results in an 'FAIL 9' message on the 4700-series slaving calibrator.

9.4 DIGITAL CIRCUITRY

9.4.1 Introduction

Fig. 9.4.1.1 is a simplified block diagram of the 4600 digital circuitry. It shows the main functional blocks and signal paths associated with

selection of Slave or Solo mode, and the output On/Off switching. These are examined in more detail in the subsequent descriptions.

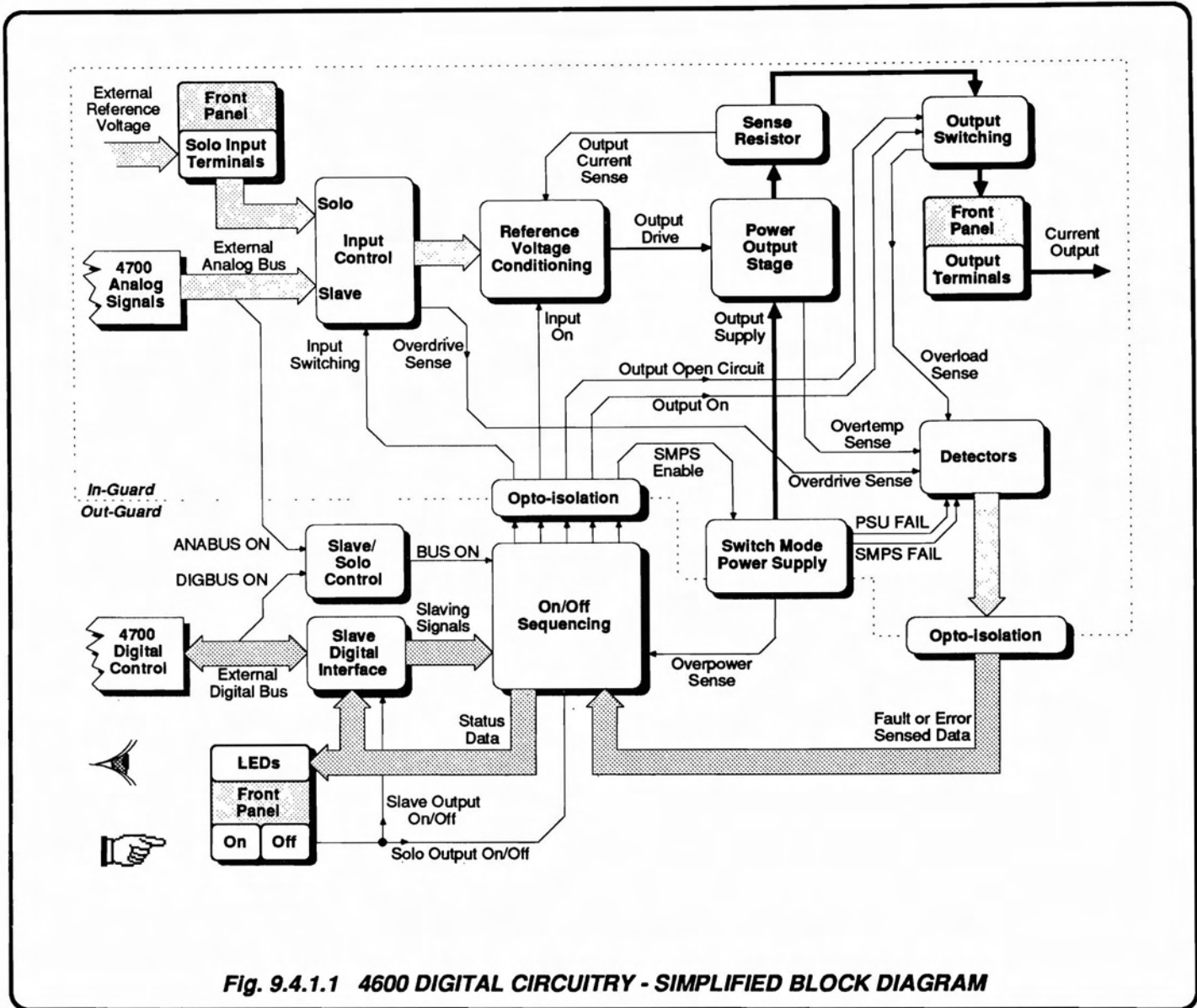

Fig. 9.4.1.1 4600 DIGITAL CIRCUITRY - SIMPLIFIED BLOCK DIAGRAM

The digital section of the 4600 has to deal with both Slaved and Solo operation.

In the analog bus cable between the 4600 and its controlling 4700-series calibrator, a dedicated line (J66-4) carries a signal 'ANABUSON_L'.

Also, the digital bus cable carries the signal 'DIGBUSON_H' on J54-9. When both bus cables are connected, these two signals are passed onto the Sense PCB, where they are used to select Slave mode. If EITHER of the bus cables is disconnected, its signal is lost and the 4600 reverts to Solo mode.

The Sense PCB accommodates the central digital circuits of the instrument.

Circuit diagram DC400788 sheet 1 (Section 10, page 10.1-5) contains mostly those functions concerned with interfacing the Slaving signals carried on the Digital bus.

Sheet 2 on page 10.1-7 shows Output On/Off control and sequencing for both modes, plus the opto-isolating Out-guard / In-guard interface and front panel LED driver circuits.

9.4.2 Slaving Interface

(Circuit Diagram DC400788 Sheet 1, page 10.1-5)

4700 Processor Control

Once the 4600 is connected in Slave mode, its operation is controlled as a separate peripheral by the central processor in the controlling 4700, connected via an external 15-way cable: the 'Digital Bus'. In the 4600 the bus at J54 is connected to the Sense PCB, entering via J7 whose fifteen lines are shown on diagram DC400788 sheet 1.

Sense PCB Digital Bus Connections

At J7, three lines carry the control signals 'IA_H_D_L', 'IRD_L' and 'IWR_L'. These define the operation of an Address/Data bus 'IAD4-0', which occupies a further five lines. One input, (signal CAL_RST) is not used in the 4600, another carries the cable shield potential, and the rest refer the 4600 digital common potential to that of the controlling 4700.

Sense PCB Digital Bus Interface

This interface is designed for use in other instruments as well as the 4600, so only four of the full range of 32 addresses are used. U102 and U103 are not fitted in the 4600.

The main functions are to buffer, latch, decode and activate addresses received from the 4700; thus receiving control data into the instrument, or transmitting retrieval data back to the 4700. The GAL U105 is responsible for latching and decoding received addresses together with accompanying control signals, converting them mainly into chip-selects. This routes subsequent data to or from the selected devices. U105 also controls the send/receive mode of the interface buffer U101.

Interface Buffer U101

U101 is a standard three-state bi-directional buffer with send/receive control. Its five data channels B4-B0/D4-D0 (carrying the Address/Data bus) are controlled to send or receive data, by the SDATA_H signal from U105-13 at U101-1/17; the address control logic ensuring that addresses cannot be sent, only received. D4-D0 are connected as a bus AD(4-0) for distribution to the required devices. The three channels B7-B5/D7-D5 (used for the control signals) are set to receive only, their controls being connected to fixed potentials. They are passed via spike filters to the appropriate inputs of GAL U105.

Address Latch U104

The 4700 sets the IA_H_D_L signal high to identify the incoming word on B(4-0) as an address, and not data. The signal is decoded by U105 to clock the Address Latch (U104) when the new address is written on to the AD bus. The address latch drives the decoder inputs of U105 so that the read and write strobes can activate the decoder outputs when IA_H_D_L is low. Out of 32 possible addresses only four (0, 1, 2, and 3) are used. The latched address is decoded by U105 to chip-select the addressed device during the subsequent data transfer.

AD Bus Peripherals

Two latches (U108 and U109) and four three-state buffers (U106, U110, U111 and U112) are chip-selected by U105. The two latches are used as a register for commands from the 4700, and the four buffers pass status information back to the 4700 when read.

Address Decoder U105

U105 has two types of input. Five lines are allocated to the output of the Address Latch (A4-0), and five for the following control signals:

- Buff'd IA_H_D_L (pin 2) sets U105 to deal with Address latching or decoding;
- Buff'd IWR_R (pin 4) pulsed low to write address or data, depending on state of IA_H_D_L;
- Buff'd IRD_L (pin 3) pulsed low to read retrieval data, when IA_H_D_L is low;
- POR_L (pin 11) low for 500ms at power on, and whenever regulator U501 detects a power failure.;
- CK_BUSON_L (pin 1) clocked low by the first 30ms clock after both external bus lines are connected with 4700 active.

BUS ON Decode

U107-3/6 provide an 'AND' function so that the 4600 cannot be in Slave mode unless both Analog and Digital Bus connectors are plugged in at both ends. The ANABUS_L signal is passed via the connected Analog bus cable to set U107-1/2 input to 0V (instead of being pulled to +5V). The signal is inverted at U107-3 (this can be read via U110 and the external digital bus) and is 'NAND'ed with DIGBUSON_H at U107-6. DIGBUSON_H is driven by the 4700 +5V supply.

BUS ON Delay

U315 is an offset voltage comparator whose +2.45V reference 'REF_2V5' is shared with the overpower detector circuit (the other half of U315 on circuit diagram DC400788 sheet 3, page 10.1-9). Changes in the state of U107-6 are delayed by approximately 300ms before reaching changeover potential at the input to U315-5. This acts as a debounce when the external cables are being connected or disconnected. Resistor R111 speeds up the transitions when detected and provides hysteresis. The output at U315-7 passes out as the signal BUSON_L to the On/Off Sequence Controller U204-6, where it is clocked through as the signal CK_BUSON_L, used to synchronize the sequencer U206-2 (DC400788 sheet 2, page 10.1-7).

Slaving Signal CK_BUSON_L - Reset Inhibit

The CK_BUSON_L signal is used by U105 to inhibit the Reset command (decoded from signals RD and WR when both are true) if the Analog bus is disconnected. This is needed to avoid resetting the 4600 in Solo mode if and when Reset is required for any other device which may also be connected to the same Digital bus.

U105 Decoder - Address and Command Decodes

The tables in Appendix 1 relate each encoded U105 input to its decoded output. For the Command Decodes, a 'Decode Group Name' is attached to link each input to its Grouped Output, presenting inputs and outputs on separate tables to utilize the available space. These names broadly describe the effects of the commands.

Address Selection

Under the control of the processor in the slaving 4700, address selection proceeds as follows:

- The current address is placed at the inputs to the Address Latch U104;
- The 4700 causes U105 to generate the LTAD_R signal which clocks and latches the current address into U104;
- The new latched address is passed to the A4-Ø inputs of U105 to be decoded into the chip-select for the addressed register.

Command Data

Two registers (U108, U109) share the same address 'WØ1_L'. All operational commands emanating from the 4700 are written as data into these two latches (refer to command group 'Write Data to Address WØ1_L' in the U105 Decoder table in Appendix 1).

Retrieval Data

Four non-inverting 3-state buffers carry retrieval data and are accessed by 'read' chip-selects from U105:

- U106 by RØØ_L (U105 pin 14)
- U110 by RØ1_L (U105 pin 16)
- U111 by RØ2_L (U105 pin 17)
- U112 by RØ3_L (U105 pin 18)

A buffer is deselected by its chip-select signal being false (high). Its outputs are then at high impedance. When its chip-select is true (low), its inputs are buffered without inversion onto the AD bus.

U106

All inputs are pulled low, so when selected, all AD bus bits are low. This is used by the 4700 processor to determine whether the DIGBUS cable is connected.

If this common interface were to be used in other peripherals on the external Digital Bus, the inputs to U106 could be hard-wired to other codes, and be interrogated as a means of identifying the responding peripheral. However, a different set of addresses would be used.

U110

This reads the state of the Command Latch (U108 and U109) outputs; the condition of the front panel On and Off keys (so that in Slave mode, these keys can duplicate the slaving operation of the 4700 On and Off keys); and the state of the ANABUSON_L signal (buffered and inverted by U107-3). The 4700 processor reads back ANABUSON_L to ensure that the analog bus is connected.

U111

Whereas U110 reads the state of the front panel On/Off keys, U111 reads the actual commanded On/Off state. It also retrieves fault information:

- LTPSUFL_H: The Switch Mode Power Supply has tripped off or another In-Guard supply has failed.
- OVTEMP_H: The Output Assembly heatsink temperature is excessive and the Switch Mode Power Supply is disabled until this condition clears.
- OVDRLD_H: The input is being overdriven or the output overloaded (excessive voltage demand).

In each of these cases of failure, the output has been sequenced Off.

U112

The inputs are states which occur during the output On/Off sequence. They are provided for diagnostic use during manufacture, and are not programmed for retrieval by production 4700-series calibrators.

Interface Control Decodes

Two further outputs from U105 are used to control the operation of the slaving interface (refer to 'Command Decodes - Grouped Outputs' on the U105 Decode table):

- LTAD_R: To read or write a register, its address is first written to the Address Latch U104 by setting IA_H_D_L high and pulsing IWR_L low with the required address on the AD bus. This sets LTAD_R low at U105-12 and U104-11. When latched, the outputs from U104 drive the decoder inputs of U105, so that the read and write strobes can activate the decoder outputs when IA_H_D_L is low.
- SDATA_H: To read one of the retrieval data buffers U106, U110, U111 or U112; IA_H_D_L is set low, and IRD_L is pulsed low. While IRD_L is low the signal SDATA_H at U105-13 is true, setting the Bus Buffer U101 into its 'send' mode (U101-1/17). The data from the addressed retrieval buffer is thus driven from the AD bus onto the external IAD digital bus back to the slaving 4700.

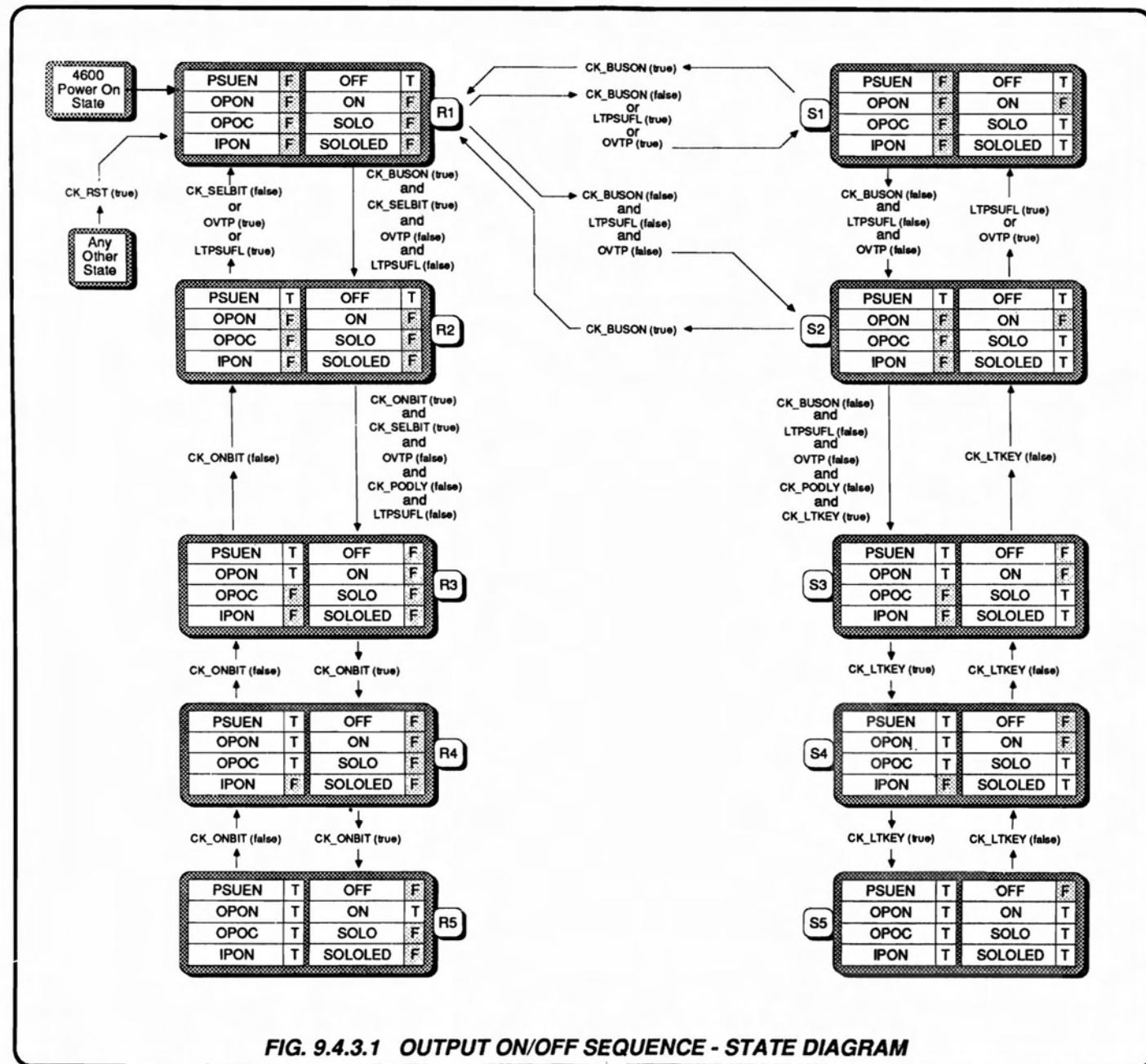

FIG. 9.4.3.1 OUTPUT ON/OFF SEQUENCE - STATE DIAGRAM

9.4.3 Output On/Off Sequencing

(Circuit Diagram DC400788 sheet 2, page 10.1-7)

Slave/Solo Control

The 4600 is designed to operate, at any time, in one of two modes:

- Slave mode, in which the 4600 output is referenced to, and controlled by, a controlling 4700-series calibrator;
- Solo mode, where the 4600 output is referenced to any suitable voltage source, but otherwise controls itself.

Mode selection is thus necessarily carried out by the 4600 itself. Two signals, one carried by each of the external bus cables, are decoded on the Sense PCB (refer to page 9.4-2) to generate signal BUSON_L.

When the external Analog and Digital bus cables are correctly connected, BUSON_L is true (low). If the 4600 is already operating in Solo mode when the cables are connected, the 4600 automatically turns its output off and reverts to a Slave mode state with output off. The OUTPUT ON key on either the 4700 or 4600 must then be pressed to reassert output on.

Similarly, if operating in Slave mode, BUSON_L is true (low). Removal of any one of the cables will set BUSON_L false (high), and the 4600 turns the output off and reverts to a Solo mode state with output off. The OUTPUT ON key on the 4600 must then be pressed to reassert output on.

The actions required to effect these mode changes form part of the sequencing circuitry described below.

GALs U204 & U206 - Signal Processing

The logic diagrams for the GAL U204 Sequence Controller can be found in Appendix 1 to this section, on pages 9-A1-2/3. They relate each of the eight U204 outputs to its constituent inputs.

The State diagram is given on the foldout of this page; and tables for the GAL U206 Sequencer can be found in Appendix 1 to this section, on pages 9-A1-4/5. They show how changes of inputs generate the Output On and Off sequences.

Power On or Reset

(Refer to Fig. 9.4.3.2)

The power on reset signal POR_L is asserted true (low) when the regulator U501 (Circuit Diagram 400788 sheet 5, page 10X) detects a power failure, or during a delay of some 900ms (C502) after the instrument has been switched on. At Power On this signal sets all U206 outputs to high impedance by driving U206-11 high via U207-8, to prevent the energization of in-guard relays by signals derived from U206.

The slaving reset command from the 4700 (BUSON_L low with both RD_L and WR-R low together) is ORed with POR_L in the Address Decoder U105 to generate the signal RST_L. U205 synchronizes RST_L to the falling clock, and when CK_RST_L is true the sequence controller U204 is reset. U204 in turn resets the Key Latch by U109-13, also resetting the On Latch and Control Latch by U109-1 and U108-1 (sheet 1) respectively. The three signals LTKEY, ONBIT and SELBIT all become false so that if the output is on, whether the 4600 is in Slave mode or Solo mode, the Output Off sequence starts (refer to the state diagram for U206). The rest of the system is not reset until three falling clock edges later at U206-9 (refer to 'Clock Dependence', on the next page).

Transistor Q201 provides a signal PSUCLP_L which affects the line input to the SMPS. To avoid excessive inrush current to the SMPS reservoir capacitors, a resistor and fuse are placed in series with the input to the bridge rectifier circuit at Power On. PSUCLP_L false (high) energizes relay RL3 on the SMPS Main PCB, whose contact shorts the fuse F2 and resistor R1. For normal operation, POR_L and the delayed CK_RST_L are both false (high), so PSUCLP_L is pulled high by Q201, the relay is energized and the resistor/fuse short is applied.

At the instant of Power On, POL_L is true, so the short is absent. PSUCLP_L cannot go false until the delayed CK_RESET_L is also false some 1 second after Power On, when the +5V supply has settled. If regulator U501 senses a fall of 150mV in the +5V supply, POR_L is again driven true, so PSUCLP_L and CK_RST_L go true, followed by the delayed CK_RST_L. The output is sequenced off and the resistor/fuse short is removed until the +5V supply is restored.

Output On/Off Sequencing

Whether in Slave or Solo mode, the output is sequenced on in a controlled way paying due regard to user-errors or any faults which may exist within the in-guard analog circuitry. Four signals are returned via opto-couplers, which when true inhibit the output on sequence:

- PSUFL:** True if any in-guard power supply fails, including the Switch Mode Power Supply (SMPS). In the case of the SMPS, PSUFL clears to false (in-guard) when the SMPS enable (PSUEN) goes false in response to the fault. For this reason the PSUFL signal is latched out-guard in U204, and cannot be cleared until U204 is reset by CK_RESET. PSUFL starts the Output Off sequence, and the SMPS is disabled.
- OVTP:** True if the output stage heatsink temperature is excessively high, and the Output Off sequence is started. When the sequence is finished, the SMPS is switched off until OVTP clears to false.
- OVDV:** True if the selected input (Slave or Solo) is being overdriven. The output is sequenced off.
- OVLV:** True if the output voltage (compliance) becomes excessive. The output is sequenced off, but this action will set OVLV false in-guard. The OVLV signal is therefore stretched to approx. 1 second by monostable U202-7. This allows time for the slaving 4700 to acquire the fault signal, and the OVERLOAD LED remains lit until the monostable times out.

The logic sense of these signals is arranged so that at Power On, they will not become active. If an opto-coupler fails, then the control function will be deselected or the status will indicate a fault.

Clock-Dependence

All state changes in the sequences occur on the edges of a 30ms clock waveform, generated by astable U201. This allows time for relay contacts to be made for one state before passing to the next. The output is sequenced on the rising edges by U206, whose inputs from U204 are also synchronized to rising edges, whereas those from U205 are transferred on falling edges.

When RST_L goes true at U205-13, the clocked CK_RST_L from U205-12 to U204-9 occurs on the next falling clock edge; but CK_RST_L from U205-18 to U206-9 is transferred some 90ms later, due to the three extra stages of U105. During this time the reset action of U205 has time to force U206 to sequence the output off, before U206 is itself reset.

Power On Status

(Refer to Figs. 9.4.3.1 [Page 9.4-4] and 9.4.3.3 [Page 9.4-7])

From Fig. 9.4.3.1 it can be seen that Slave state R1 is the Power On condition, and R1 is also entered whenever the delayed CK_RESET signal goes true.

S1 Signal CK_BUSON is false if one of the external bus cables is not connected, so in this case the status transfers to either S1 or S2 at the next rising clock edge, dependent on the condition of the LTPSUFL (true if an analog power supply fault is reported) and OVTP (true if the Output PCB heatsink temperature is excessive). State S2 is the quiescent output-off state for Solo operation. State S1 is only entered in the event of a fault as reported by LTPSUFL or OVTP.

R1 If the external bus cables are correctly connected, then CK_BUSON will be true, then the sequence remains in its quiescent Slave output-off state R1 until further instructions are received from the 4700.

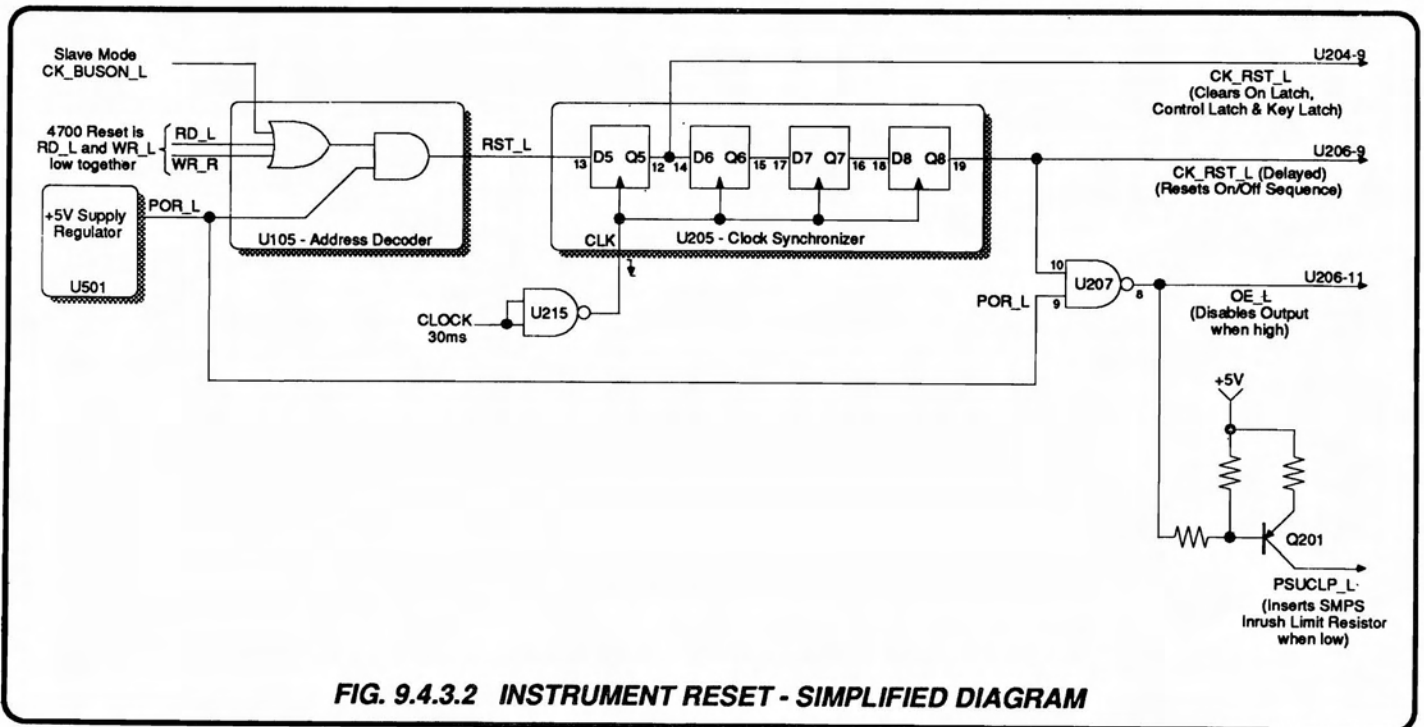

FIG. 9.4.3.2 INSTRUMENT RESET - SIMPLIFIED DIAGRAM

Solo Mode 'On' Sequencing

(Refer to Figs. 9.4.3.1 [Page 9.4-4] and 9.4.3.3 [Page 9.4-7])

From Fig. 9.3.3.3 it can be seen that the Front Panel ON key provides a rising clock edge to the key latch U109, whose permanently-high D input results in LTKEY_L true (low). Conversely the OFF key resets the latch, via U204 and CLR_LTKEY_L, to set LTKEY_L false (high). On the next falling 30ms clock edge after either of these actions, LTKEY_L is clocked to the output of the Clock Sync Latch U205, as CK_LTKEY_L at U206-6. What happens next depends on the current status of the on/off sequence, and the conditions of the other U206 inputs.

S2 Under normal Solo mode output-off conditions, the status is quiescent in S2 state, and the SMPS is powered up - PSUEN true turns the SMPS on via opto-coupler U212-5 and J4B-4 (refer to Paras 9.3). The OFF and SOLO LEDs are lit.

S3 When the Front Panel OUTPUT ON switch is pressed, CK_LTKEY_L at U206-6 is true and the status transfers to S3 state at the next rising clock edge, providing the SMPS is not in the process of being turned on. The PSUEN delay monostable U202-10 causes CK_PODLY to be true for approx. 1 second after the sequence enters S2 state, to inhibit selection of Power On until the SMPS has powered up and settled.

In S3 state U206-14 OFF_L signal is false (high), so the OFF LED is unlit. Note that both ON and OFF key LEDs remain unlit during sequencing on or off.

The OPON_L signal at U206-17 is true (low), energizing the output relay (A) which connects the output stage and sense resistor to the Front Panel OUTPUT terminals. OPON is transferred into guard via U213-8, also removing the inhibit placed on the overload detector in S1 and S2 states (OVLN_INH_L goes false at U213-8).

The OPOC signal remains false, ensuring that the internal load is not removed from across the output (relay RL 403 on the Sense PCB remains un-energized, so the 18Ω resistor R437 across the output is not open-circuited - see circuit diagram DC400788 sheet 4 page 10.1-11).

From S3 state the sequence tracks through to S5 on successive rising clock edges, so long as the CK_LTKEY_L signal remains true and the Key latch is not cleared by the signal CLR_LTKEY_L. To clear the Key Latch either the OFF key must be pressed, or there must be a power supply failure, an overdrive, overload, overtemperature or reset condition; or the external bus cables must have been connected (refer to the U204 transfer-function diagrams in Appendix 1).

S4 This state can only be entered from S3 if CK_LTKEY is true at the next rising clock edge. The only action is to open-circuit the internal load resistor mentioned above for S3, with the faults associated with CLR_LTKEY_L (true) absent. This is done by the OPOC_L signal at U206-16 going true.

S5 The final stage in setting the output on, is to activate the reference voltage from the external voltage source. To do this, the IPON signal is set true, which open-circuits FET shorts to 'Common 1' in the Sense Amplifier (see circuit diagram DC400788 sheet 4 page 10.1-11).

Solo Mode 'Off' Sequencing

S5 - S2

Once the output is on, the instrument status remains at S5 until something occurs to set CLR_LTKEY true (low). For normal operation, this will be by the Front Panel OFF key being pressed; the other causes are shown on the U204 transfer-function diagrams in Appendix 1. Then CK_LTKEY is set false and the status is sequenced back through S4 and S3 to S2, by successive rising clock edges.

S2 If the Output Off sequence was started by pressing the OFF key, then the status remains quiescent in S2. If it was started by a power supply failure (LTPSUFL) or an overtemperature (OVTP), then status transfers to S1. But if the external bus cables were reconnected while the output was on (although this is not recommended), the CK_BUSON (true) signal will initiate the Output Off sequence back to S2, and then the next rising clock edge will cause a transfer to Slave mode R1.

S1 This is really a holding state for psu and overtemperature faults. When the fault is cleared, the status reverts to S2.

Slave Mode Control

The external Digital Bus cable carries nine signal lines so that the 4700 can address peripherals connected to the bus. To read or write an address the 4700 writes the required address into the Address Latch U104, with the Address/Data control line IA_H_D_L set to 'Address' (high). To write command data to the 4600, the address decode from U105 chip-selects the Control Latch U108 and On Latch U109.

Control data is written into these latches via the internal AD(4-0) bus. Each bus line carries a separate signal bit, and the whole combination is decoded by U107, U108 and U109 for specific purposes, as shown in Table 9.4.3.1, below.

AD4 TEST3_H	AD3 TEST2_H	AD2 TEST1_H	AD1 ONBIT_H	AD0 SELBIT_H	Decode
X	X	X	0	0	Output Off - Power Supply Off
X	X	X	0	1	Output Off - Power Supply On
X	X	X	1	1	Output On - Power Supply On
0	X	X	1	0	Output Off - Power Supply Off - Enable Test Mode
0	0	0	1	0	Test - No LED selected
0	0	1	1	0	Test - Solo LED selected
0	1	0	1	0	Test - On LED selected
1	1	1	1	0	Test - Off LED selected
1	0	0	1	0	Test - Overload LED selected
1	0	1	1	0	Test - Overdrive LED selected
1	1	0	1	0	Test - Overtemp LED selected
1	1	1	1	0	Test - Psu LED (green off / red on selected)

Table 9.4.3.1 AD(4-0) Internal Bus - Command Signal Decodes

Slave Mode Signals from the 4700

(Refer to Fig. 9.4.3.3)

The Slaving 4700 uses two main signals to control the Output On/Off switching in the 4600:

- 'SELBIT': true when 4700 10A range is selected. Its function is to turn on the SMPS, ready to set the output on.
- 'ONBIT': true when 4700 10A range and Output On are selected.

When the 4700 is not in the 10A range, both signals are false.

Slave Mode 'On' Sequencing

In Slave mode, the 4600 output can be switched on and off using the front panel keys on either the 4700 or the 4600. The 4600 ON and OFF key states are returned as KON_H and KOFF_H to the digital bus interface and thence to the 4700, which processes them to set the ONBIT bus message either true or false. Thus ultimate control still remains with the slaving calibrator, as the Key Latch U109-8 remains cleared (high) by BUSON_L true whenever the 4600 is in Slave mode. In the following sequence description, either the 4700 or 4600 front panel ON/OFF keys will produce the required effect.

Consider the condition before the 4700 10A range is selected. Both SELBIT and ONBIT signals are false, and with the two external bus cables connected, the BUSON signal is true. The 4600 is already powered on, in R1 state.

Once the 4700 10A range is selected, the 'SELBIT true' signal is transmitted across the digital bus to the 4600. This is decoded by U105, and latched into U108/109 to give SELBIT_L true at U108-3. SELBIT_L is applied to U204-7 and, providing no power supply or overtemperature faults are signalled, the CK_SELNPSUNTP_L is set true at U204-15 and U206-4, on the next rising 30ms clock edge.

R1 Under normal Slave mode 10A unselected conditions, the status is quiescent in R1 state, and the SMPS is powered off.

R2 CK_SELNPSUNTP_L true sets the conditions required for transfer from state R1 to state R2. The only effect on U206 is to set PSUEN_L true at U206-18. PSUEN true turns the SMPS on via opto-coupler U212-5 and J4B-4 (refer to Paras 9.3). The OFF LED is lit.

R3 When the 4700 or 4600 Front Panel OUTPUT ON switch is pressed, the 'SELBIT and ONBIT true' signal is transmitted across the digital bus to the 4600. This is decoded by U105, latched into U108/109 and combined at U107-11 as ONBIT_L true, which is latched on the next falling 30ms clock edge into U205. CK_ONBIT_L at U205-6 and U206-7 is true and the status transfers to R3 state at the next rising clock edge, providing the SMPS is not in the process of being turned on. The PSUEN delay monostable U202-10 causes CK_PODLY to be true for approx. 1 second after the sequence enters S2 state, to inhibit selection of Power On until the SMPS has powered up and settled.

In R3 state U206-14 OFF_L signal is false (high), so the OFF LED is unlit. Note that both ON and OFF key LEDs remain unlit during sequencing on or off.

The OPON_L signal at U206-17 is true (low), energizing the output relay (A) which connects the output stage and sense resistor to the Front Panel OUTPUT terminals. OPON is transferred into guard via U213-8, also removing the inhibit placed on the overload detector in R1 and R2 states (OVLN_INH_L goes false at U213-8).

R3 (Contd)

The OPOC signal remains false, ensuring that the internal load is not removed from across the output (relay RL 403 on the Sense PCB remains un-energized, so the 18Ω resistor R437 across the output is not open-circuited - see circuit diagram DC400788 sheet 4 page 10.1-11).

From R3 state the sequence tracks through to R5 on successive rising clock edges, so long as the CK_ONBIT_L signal remains true and the Control latch U108 and On latch are not cleared (by CLR_CTRL_L or CLR_ON_L).

R4 This state can only be entered from R3 if CK_ONBIT is true at the next rising clock edge. The only action is to open-circuit the internal load resistor mentioned above for R3. This is done by the OPOC_L signal at U206-16 going true.

R5 The final stage in setting the output on, is to activate the reference voltage from the external voltage source. To do this, the IPON signal is set true, which open-circuits FET shorts to 'Common 1' in the Sense Amplifier (see circuit diagram DC400788 sheet 4 page 10.1-11).

Slave Mode 'Off' Sequencing

R5 - R2

Once the output is on the instrument status remains at R5 until something occurs to set CK_ONBIT false (high). For normal operation this will be by the 4700 or 4600 Front Panel OFF key being pressed; other causes are shown on the U204 transfer-function diagrams in Appendix 1. Then CK_ONBIT is set false and the status is sequenced back through R4 and R3 to R2, by successive rising clock edges.

R2 and R1

If the Output Off sequence was started by pressing the 4700 OFF key, then the status remains quiescent in R2. If it was started by a power supply failure (LTPSUFL) or an overtemperature (OVTP), then status transfers to R1.

If an external bus cable is disconnected while the output is on (although this is not recommended), the CK_BUSON (false) signal initiates the Output Off sequence to R1, and then to S2.

R1 If the Output Off sequence was started by selecting a 4700 output range or function other than 10A while the output was on, then the 4700 would first have cleared ONBIT, and then SELBIT. The ONBIT_L signal at U107-11 is set false (high), and the SELBIT_H signal at U108-2 and U107-13 is set false (low). This initiates a transfer to R2, then R1.

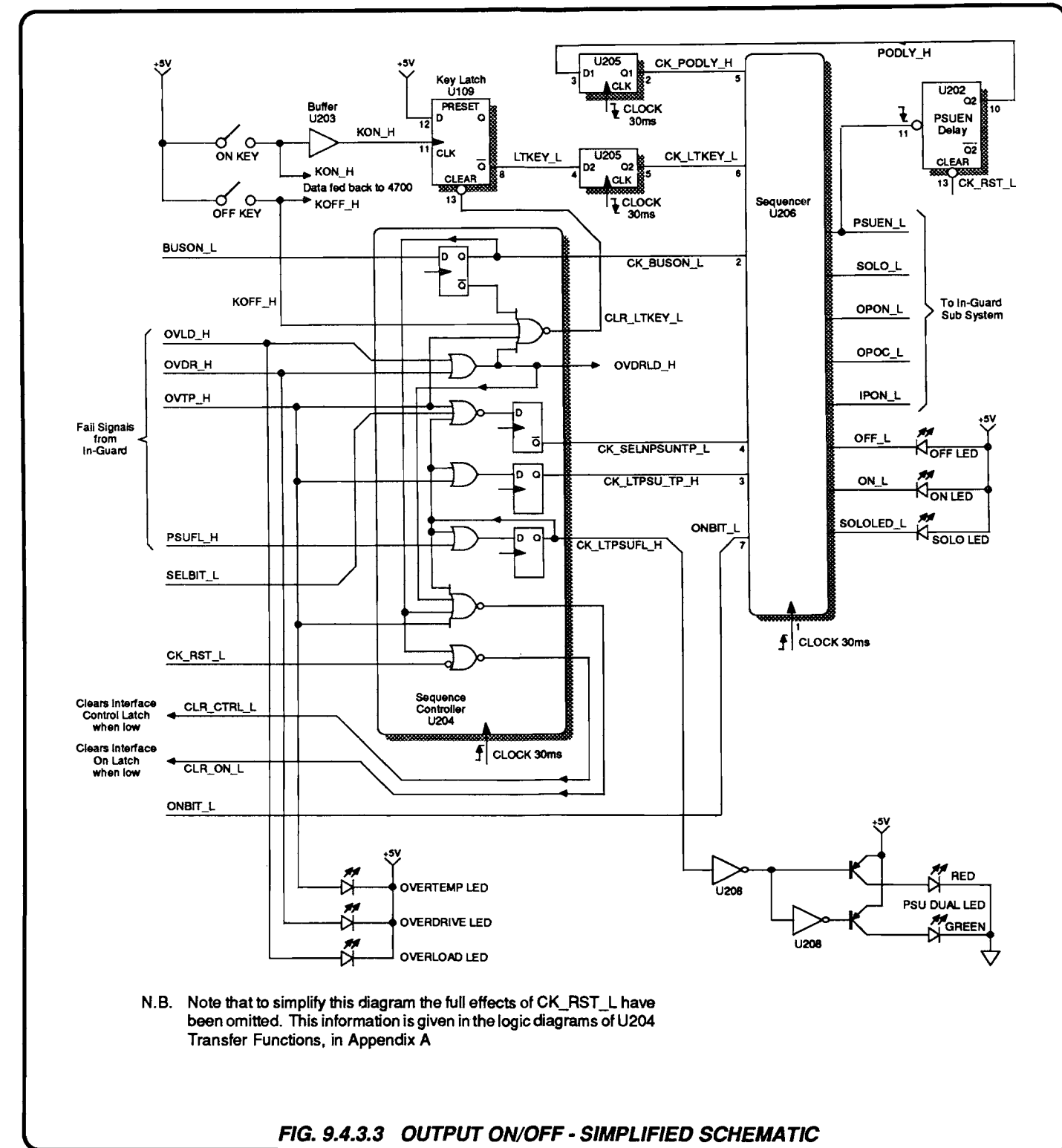

FIG. 9.4.3.3 OUTPUT ON/OFF - SIMPLIFIED SCHEMATIC

9.4.4 In-Guard/Out-Guard Opto-Couplers*(Circuit Diagram DC400788 sheet 2, page 10.1-7)*

Five devices (U210 - U214) are used to transfer digital signals across the Guard isolation barrier.

Status Signals*(from inguard to outguard)*

Four fault signals are passed out of guard from the in-guard detectors on the Sense PCB, to affect the On/Off sequencing:

- PSUFL (U210) True when the SMPS or any other in-guard supply has developed a fault.
- OVTTP (U210) True when the Output Assembly heatsink temperature is excessive.
- OVDR (U211) True when the differential amplifier is being overdriven.
- OVLDD (U211) True when the output voltage is excessive (overcompliance).

Control Signals*(from outguard to inguard)*

Six control signals from the sequencer output are passed into guard to alter the states of the analog circuitry; giving effect to the sequencing commands:

- SOLO (U212) When true, switches the source of input from the Analog Bus cable to the Front Panel INPUT terminals, and enables the internal calibration adjustments.
- PSUEN (U212) When true, initiates power-up in the SMPS.
- OVLDD_INH (U213) When true (low), inhibits the overload detector in R1, R2, S1 and S2 states.
- OPON (U213) When true, energizes the relay which feeds the high current from the Output Assembly to the Front Panel OUTPUT terminals.
- OPOC (U213) When true, disconnects the internal load from across the output of the Output Assembly.
- IPON (U214) When true, turns off shorting FETs in the Sense Amplifier.

Opto-Coupler Power Supplies

On the outguard side of the barrier, the opto-isolators are tied to the general digital +5V regulated supply via a separate route (+5V_7) from the +5V and Common star points. This route is separately decoupled to limit the effects of any rapid in-guard edges which could otherwise be transferred, via the opto capacitance, to the rest of the digital circuitry. For the same purpose, each of the signal paths on the outguard side of the opto devices has individual HF decoupling.

All the inguard control signals except PSUEN are powered from the Sense Assembly $\pm 15V_8$ supply for relays. PSUEN is destined for the SMPS, so it is tied to the SMPS $\pm 15V_2$ to avoid circulating currents, which could otherwise pass through the main sense resistor. The inguard status signals are powered from the $\pm 15V_3$ route, so their opto LEDs (U210, U211) are also referred to the $\pm 15V_3$ supply.

9.4.5 Front Panel LED Signals

(Circuit Diagram DC400788 sheet 2, page 10.1-7)

Eight status indicator LEDs are located on the Front Panel. Two are fitted into the ON/OFF keys, the remaining six are positioned together in the upper right-hand group. The operation of the LEDs, under the control of their driving signals, is described below.

LED Supplies

The common cathode of the red/green Psu indicator D111 is taken to the 0V_RAW_OG line, which is the common output from the bridge rectifier W001 on the Front Panel. This is the rectifier used to drive the Sense PCB +5V main digital supply regulator, so the 0V_RAW_OG line is tied to the Common star-point for that supply, from which the Psu LED signals are driven. Each of these signals is true (to light its LED) when high; they cannot both be lit at the same time.

All other LED anodes are connected directly to the Sense PCB +5V_5 supply line, via J9-20 on the Sense PCB and J31-20 on the Front Panel. Their cathodes are driven by signals, derived from the Sense PCB digital circuitry, which are true (to light the LEDs) when low.

ON Key LED

This is lit only after all the stages of the Output On sequence have been completed, that is in either S5 or R5 state.

OFF Key LED

This is lit only in stages R1, R2, S1 and S2 of the Output On sequence.

N.B. To avoid an ambiguous indication to the user, the transitory states R3, R4, S3 and S4 ensure that both ON and OFF LEDs are not lit.

Solo LED

This is lit only when the sequencer U206 has activated Solo mode, i.e. is in one of the five states S1 to S5.

The ON and OFF key LEDs and the SOLO LED are driven, directly via isolating diodes, by outputs ONLED_L, OFFLED_L and SOLOLED_L respectively from the Sequencer U206 in the Sense PCB.

Overtemp LED

This is lit by the TEMPLED_L signal being true (low). TEMPLED_L originates at a thermistor, attached to the heatsink for the power stages, in the Output PCB (Circuit Diagram DC400789, page 10.1-15). One end of the thermistor is connected to +15V_3, and the other (signal RT1) to the inverting input of the Temperature Sense comparator U301-2 (Circuit Diagram DC400788 sheet 3, page 10.1-9). At normal heatsink temperatures the high thermistor resistance in series with R337 holds RT1 at a low enough voltage to ensure that U301-1 open-collector output is pulled high by R339. As the temperature rises above normal, the negative thermal coefficient of the thermistor reduces the thermistor resistance so that RT1 voltage rises above the reference, pulling U301-1 low. This is signal OVERTEMP, which is true when low.

OVERTEMP is inverted by the open-collector buffer U318-7/10, becoming OVTP_H at the input of the opto-isolator U210-3. At normal temperatures the opto LED is conducting (OVTP_H low) and the transistor collector output at U210-6 is low; but when a high heatsink temperature sends OVTP_H high, the LED cuts off and so does the transistor, sending U210-6 high. This signal is transferred via TP215 and buffer U203 to U204-3, where it is combined with other signals to affect the On/Off sequence.

The outguard OVTP_H signal is also passed to the external bus interface at U111-10 for transmission to any controlling 4700, and to the LED Driver at U208-2. The signal is inverted at U208-15 as TEMPLED_L, which energizes the Overtemp LED on the Front Panel by pulling its cathode low.

Overdrive LED

This is lit by the OVDRLD_L signal being true (low), indicating that the Input Reference Voltage to the 4600 is too large ($>12.25V$). OVDRLD_L originates as the voltage output V_{in} of the main differential amplifier (gain ≈ 0.7), at TP414 (*Sheet 4*). This voltage is passed to the inverting buffer (gain ≈ 0.3) at U314-6 (*Sheet 3*).

Overdrive Comparator

The buffered signal is applied to a window comparator with hysteresis at U303-4/7 (whose $\pm 2.45V$ reference D303/D305 is shared with the Overload comparator). If the buffer output is between $\pm 2.45V$, both comparator open-collector outputs at 303-1/2 are pulled high at inverter U304-1/2 by R322. But if the buffered voltage (DC or peak AC) is outside this window, one of the comparator outputs and the inverter input U304-1/2 will be pulled low.

Single Pulse Detection (with Glitch Rejection)

The inverted comparator output at U304-3 is applied to two delay monostables at U305-12 (15ms) and U305-4 (90ms). It is also applied to D308, part of a diode OR gate with D304 (but used in negative logic as an AND function). With no overdrive, the U304-3 is low at 0V₃ potential. This pulls TP306 low via D308, and the mono output U305-9 is open-collector.

Any overdrive output from the comparators will appear at U304-3 as a +15V pulse (AC), or the positive-going edge of a +15V DC level. This signal releases diode D308 so TP306 can rise. But the pulse is also applied to U305-12, which when triggered generates a 15ms negative-going pulse at U305-9. This takes over to pull TP306 low after a 220ns positive 'pip' at TP306, due to propagation time in U305. The pip amplitude is reduced by absorption in C312 and U304-6/8 remain below threshold level.

If the positive output pulse from the inverter at U304-3 is less than 15ms, then it will return to low before the mono times out and TP306 will remain low. But if it persists until after the mono has timed out, then both diodes will be cut off, and TP306 will be pulled high by R324. Thus TP306 is set high only if the comparators respond to an overdrive which persists for more than 15ms. This is illustrated in the waveforms of Fig. 9.4.5.2.

AC Overdrive Detection

The circuit described above cannot detect overdrives for AC of higher frequencies, as the comparator pulses will be short enough to be rejected as glitches; so the inverted comparator output is applied to a second mono. Any positive pulses applied to U305-4 will cause a negative-going output pulse from U305-7 of 90ms duration (the lowest frequency on AC is 10Hz). This is buffered by Q303 which charges C319 via R336 until U305 is triggered. Transistor Q314 drains constant current from C319 so repetitive overloads reduce the voltage on C319, which is applied to comparator U312.

For low frequencies, Q314 collector voltage has time to recover between successive comparator output pulses. No pulses cause the input to comparator U312-11 to fall below its +4.7V reference on U312-10, and U312-13 voltage remains low.

At higher frequencies, Q314 collector voltage is not able to recover in time for the next pulse, so this second pulse drives U312-11 below its reference threshold. U312-13 open-collector output and the NOR-gate input U304-9 are pulled up to +15V by R390.

The input is always corrected to the Overdrive detector, even when the output is off.

Detector Output Gating

Under no overdrive conditions TP306 and U312-13 are at Common 0V₃ potential. Thus the NOR-gate output at U304-10 is at +15V. Providing the output mono U306-6 has timed out, U304-5/6 are also at 0V₃ and U304-4 is also at +15V. Both diodes D333/334 are cut off and the OVERDRIVE_L signal into buffer-inverter U318-4 is pulled to +15V by R388. Thus OVDR_H at U318-13 is low (false).

DC and AC overdrives result in +15V pulses at TP306 or U312-13. U304-10 goes low, triggering the output mono at U306-5 to generate a 160ms, +15V pulse. So both NOR-gate outputs are set to 0V₃. The OVERDRIVE_L signal is true, and must remain true until at least the 160ms mono times out. Thus whenever a real (non-glitch) overdrive is detected, the OVDR_H signal is held true (high) for at least 160ms.

Fig. 9.4.5.3 illustrates this AC case.

Overload LED

This is lit by the OVLDLED_L signal being true (low). OVLDLED_L originates as the voltage developed across the 4600 output load, due to the output current flowing in it. This voltage is picked off the instrument side of the output relay, and passed into the Sense PCB at J12-3 (*Circuit Diagram DC400788 Sheet 4, page 10.1-11*). At the 'Hi' side of the internal load resistor R437, the signal SENSE_OUT goes to the non-inverting buffers at U302-3 (*Sheet 3*).

Overload Comparator

The buffered signal (buffer gain 0.66 by R330/R335) is applied to a window comparator at U303-9/10 (whose $\pm 2.45V$ reference Q303/Q305 is shared with the Overdrive comparator). If the buffered output is between $\pm 2.45V$, both comparator open-collector outputs U303-13/14 are pulled high at NOR-gate U313-6 by R344/R350. But if the buffered voltage (DC or peak AC) is outside this window, one of the comparator outputs and the NOR-gate input U313-6 will be pulled low.

Overload Detector Inhibit

The other NOR-gate input at U313-5 is controlled by the OVLD_INH_L signal which is true only during the On/Off sequence states R1, R2, S1 and S2, when OPON is false. When it is true, U313-1/2 are low, U315-5 is held high and U313-4 is held low. So no low-going pulses from the comparator will be able to affect the NOR-gate output. In the other On/Off sequence states, the inhibit is removed.

Remainder of Overload Detector

The descriptions for the Overdrive Detector apply equally to the Overload Detector, as the Glitch Rejection, AC Overload Detection and Output Gating circuits are virtually identical.

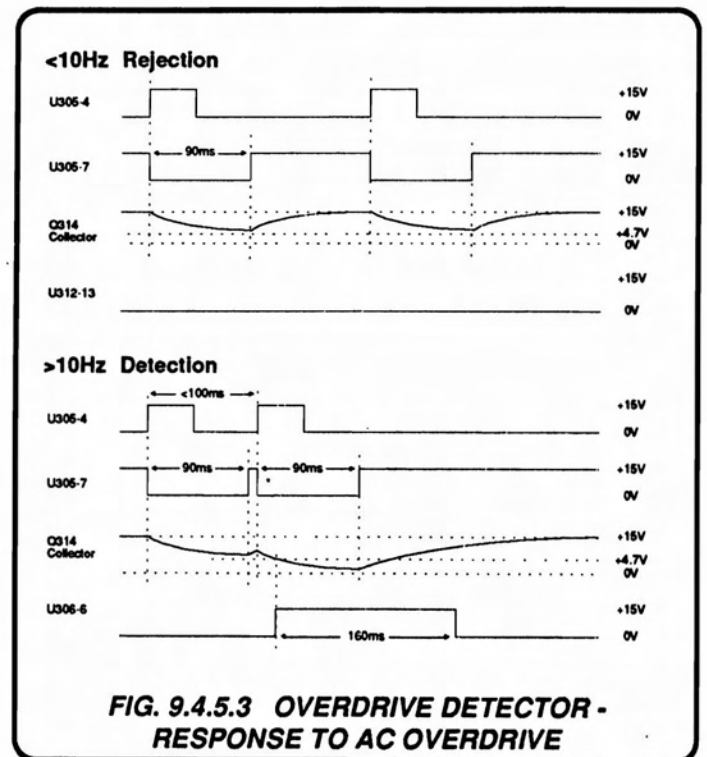
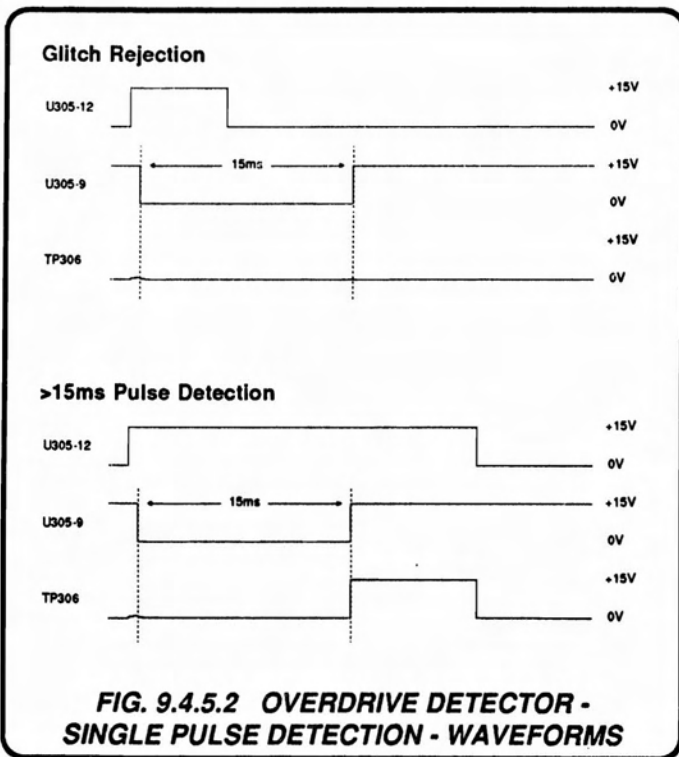
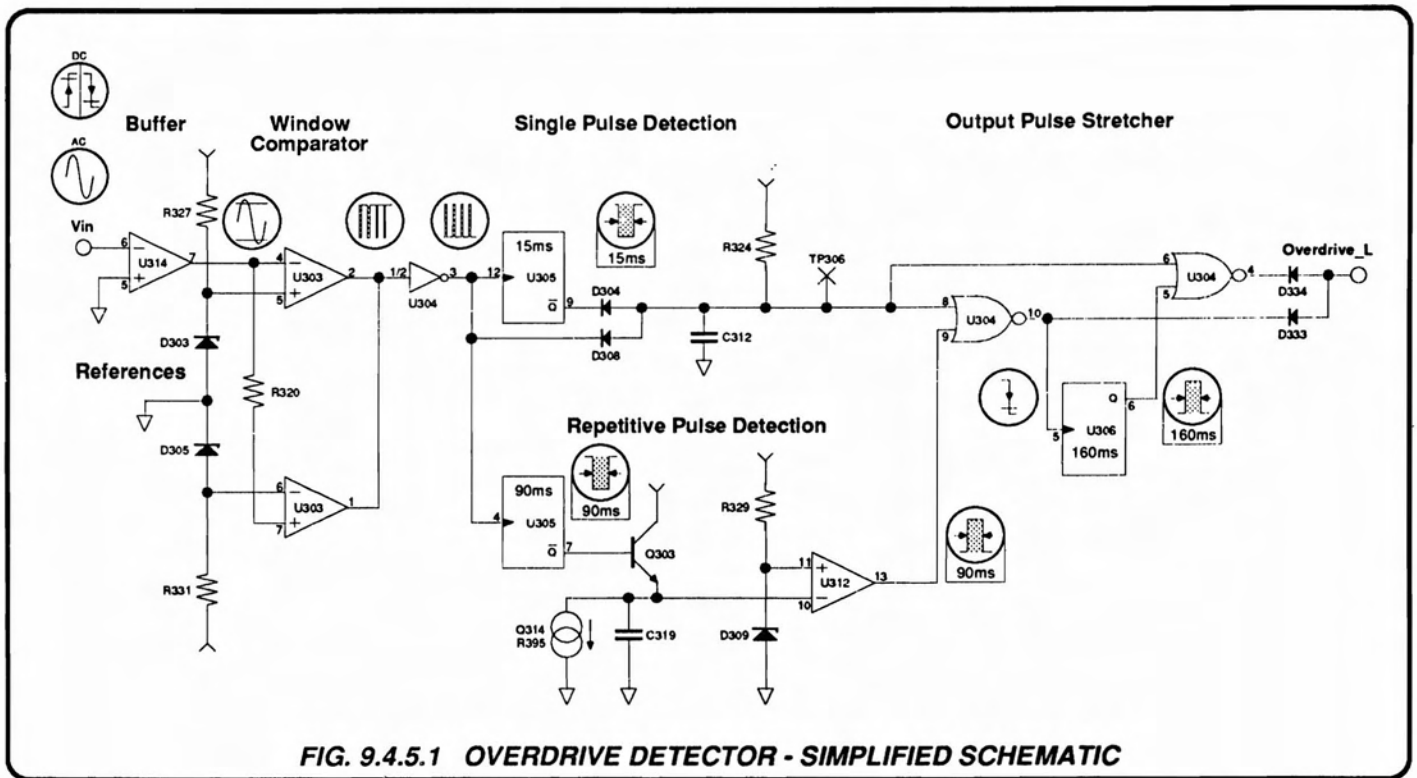

Psu LED

This is the only two-colour LED on the Front Panel. It lights green for user-confidence when the signal PSUOKLED_H is true (high), but this is merely an inversion of the PSUFLED_H signal which lights the Psu LED red if there is a fault in the Switch Mode Power Supply.

There are two signals each of which can set PSUFLED_H true:

- The PSUFL signal when true;
- The OVPWR signal when true.

PSUFL

This is a composite signal which is ORed from three other signals:

- SMPS_FAIL_L is true only when an overvoltage or undervoltage has been detected in the SMPS AND the PSUEN signal is true (i.e. does not go true if the SMPS is powered down). This signal is derived in the SMPS Control PCB at the collector of Q10, which is at +15V_2 when the SMPS is operating normally (refer to Circuit Diagram DC400791, page 10.1-19), and is passed through the SMPS Main PCB to the Sense PCB at J4C-1, and to MOSFET Q311 gate.

When false, SMPS_FAIL_L at +15V_2 turns Q311 on, lighting the internal confidence LED D326 and providing a low input to NOR-gate U319-8.

When true, SMPS_FAIL_L at 0V_2 turns Q311 off, extinguishing LED D326 and providing a high input to NOR-gate U319-8.

- PSUFAIL_2 is true when the 15V_2 supply on the SMPS Control PCB has failed. It is sensed by Q9 in the SMPS Control PCB, which conducts when the 15V_2 supply is operating normally, so PSUFAIL_2 is false at -15V_2. Failure of the supply turns Q9 off, so PSUFAIL_2 rises to 0V_2 (true). It is transferred via the SMPS Main PCB to the Sense PCB at J4C-2, and to Q310 gate.

When false, PSUFAIL_2 at -15V_2 turns FET Q310 off, setting U318-2 to +15V_3. U318-15 is pulled down to 0V_3, lighting the internal LED D330 and providing a low input to NOR-gate U319-2.

When true, PSUFAIL_2 at 0V_2 turns Q340 on setting U318-2 to 0V_3. The inverter-driver is open-collector allowing R386 to pull U318-15 to 0V_3, extinguishing LED D330 and providing a high input to NOR-gate U319-2.

- PSUFAIL_3 is true when the 15V_3 supply on the Sense PCB has failed. It is sensed by Q309, which conducts when the supply is operating normally, so PSUFAIL_3 on U318-1 is high at +15V_3. U318-16 is pulled down to 0V_3, lighting the internal confidence LED D329 and providing a low input to NOR-gate U319-1.

When the supply fails, Q309 is turned off, so PSUFAIL_3 true sets U318-1 to -15V_3. The inverter-driver is open-collector allowing R383 to pull U318-16 to +15V_3, extinguishing LED D329 and providing a high input to NOR-gate U319-1.

When the three power supplies are operating normally, the three inputs to NOR-gate U319 are low. Its output at U319-9 and U318-3 is high, so PSUFL_H at U318-14 is low (false).

When any one of the three supplies fails, one input to U319 goes low and PSUFL_H goes true (high).

PSUFL_H is transferred out of guard via non-inverting opto-coupler U210-2/7, buffered by U203-6/14, and diode ORed by D205/D206 with OVPWR_H.

OVPWR

This originates as signal PWR_SIG in the SMPS Main PCB (refer to Circuit Diagram DC400790, page 10.1-17). Transformer T3 forms part of the SMPS resonant tank circuit, and its secondary voltage is a measure of the current flowing in the tank. This voltage is full-wave rectified by D9/D10 and smoothed to become the PWR_SIG signal. Because the tank circuit operates at a constant voltage, and because the transformer secondary voltage represents tank current; PWR_SIG is a measure of current which only needs scaling to represent power.

The significant point of interest is the point at which the power in the tank (and hence in the 4600 current output circuitry) becomes excessive. So the scaling required for PWR_SIG at this point can, and is, performed by a comparator. PWR_SIG is transferred to the Sense PCB at J4A-3. (The raw secondary voltage is also transferred to the Sense PCB at J4A-2 to give a safe test point - TP301 - for viewing the tank current waveform using an oscilloscope.)

The comparator U315 is powered from +5V_5 and 0V_5, the latter being connected to case ground, as is the center-tap of the tank current monitor transformer in the SMPS PCB. PWR_SIG is scaled by divider R302/R303 and applied to the comparator U315-3 to be compared with the 2.45V reference D301. Under normal operation U315-3 is less positive than U315-2, so the comparator output at U315-1 is at 0V_5 and OVPWR_H is false. Once the reference voltage is exceeded by increased tank power; the output starts to rise and positive feedback via R303 reinforces the rise so that the output rapidly switches to 5V_5, so OVPWR_H goes true.

Generation of PSUFLED and PSUOKLED Signals

As mentioned earlier, OVPWR_H is ORed with PSUFL_H by D205/206. The ORed signal is inverted by U208-6/11, and applied to the sequence controller U204-4. The result of either PSUFL_H or OVPWR_H going true is that CK_LTPSUFL_H goes true unless the reset mode is operative (refer to the transfer function diagrams for U204, in Appendix 1 to this section).

The output CK_LTPSUFL_H is fed out of U204 at pin 14. (Note that it is also fed back internally to construct other U204 logic outputs.) It is passed to the interface register U111-6 for transmission as status data to any controlling 4700, over the external digital bus. In the 4600, it is passed through AND-gates U207-2/3/4/6 (unless Test mode is selected) to LED Driver U208-1, where it is inverted at U208-16. Q202 buffer inverts it again to become PSFLED_H, which is transferred to the Front Panel PCB.

The output on U208-16 is passed through another driver stage of U208, emerging inverted at U208-10. This output is again inverted by Q203 to become the PSUOKLED_H signal.

Green/Red Psu LED States

At the Front Panel PCB, PSUFLED_H is fed to the red anode of Psu LED D111, whereas PSUOKLED_H drives the green anode. Under normal operation, PSUOKLED_H is high and PSUFLED_H is low (even if the SMPS is not powered up) so only the green Psu LED is lit; but when an overpower occurs or one of the three power supplies fails, then the two signal states are reversed and only the red Psu LED is lit.

Test LED

The Test LED is provided for Slave mode, to indicate that the slaving 4700 has entered Test mode, and that any other 4600 LED indications are part of the 4700 test.

4700 Test Sequence

The 4700 Self Test is composed of four stages, and the 4600 is tested as a supplement to stages 3 and 4:

1. Hardware Test

Immediately after the Test key is pressed, followed by the Reset key, the 4700 program tests its hardware. No test of the 4600 hardware is performed, but if the 4600 output is On, it is sequenced Off to state R1. Consequently the Psu LED is lit green. The Test LED is lit, and remains lit throughout the test sequence.

2. Display Test

The display test itself does not affect the 4600. But on completion of this test the 4600 LEDs are lit, then extinguished, in the following sequence: Overtemp, Overload, Overdrive and Solo. The Psu LED is cycled from green to red to green.

3. Key LED Test

Each 4700 key LED is lit in turn, followed by the 4600 ON key LED and OFF key LED.

4. Key Test

After the Key LED test is completed, the 4700 MODE/FREQUENCY display shows a double offset '0', to indicate that the Key Test stage is enabled. The 4600 ON and OFF keys are also available for testing in this mode. When either key is pressed, its LED lights and the previous LED is extinguished.

Implementation in the 4600

As soon as the 4700 Test key is pressed, the 4700 requests Test mode in the 4600 via the external digital bus, by setting SELBIT false and ONBIT true. (For normal operation this is an invalid command.)

In the Sense PCB, the SELBIT and ONBIT states are passed via the internal AD bus to the Control Latch U108 (*Circuit Diagram DC 400788 sheet 1, page 10.1-5*). For the Test sequence, U108 output sets both U107-9 and U107-10 high. The NAND gate output at U107-8 is set low; this is the 'TESTEN_L' signal, which places the 4600 into Test mode.

TESTEN_L is clocked into U206 by U205 (*Sheet 2*). The effect of CK_TESTEN_L when true is to prevent U206 from supplying the OFFLED_L, ONLED_L and SOLOLED_L signals to drive the corresponding front panel LEDs. It also drives U203-1 via U207-11 so that the front panel warning LEDs will not be lit. Thus the Psu LED is green, even if there had been a power failure. U207-11 is passed via U208-5/12 as TESTLED_L true, to light the Test LED.

LED Test

After testing its own LEDs in stage 3 of the test sequence, the 4700 cycles the signals TEST1_H, TEST2_H and TEST3_H via the external digital bus, to test the 4600 LEDs. The 4600 internal AD bus versions of these signals are latched in the Control Latch U108, and passed to a decoder U209. CK_TESTEN_L at U209-2/14 enables U209 decoded outputs, which are cycled by its inputs to light each LED in turn. Diodes D202, D203 and D204 isolate each U209 low (driven) output from the corresponding open-collector outputs of the sequencer U206.

The Psu LED, which is normally green, will turn red when its code is on the decoder inputs. The unconnected output U209-7 position is encoded by the 4700 for 'no LEDs', so for this decode just the Test LED and the Psu green LED are lit.

Key Test

At the end of the LED test, when the double offset '0' is on the 4700 MODE/FREQUENCY display, the states of the 4600 ON and OFF keys are returned to the 4700 via the external digital bus.

The signals OFFKEY_H and ONKEY_H are passed from the Front Panel to the Sense PCB at J9-18 and J9-19, and read back onto the internal AD bus at U110. When either of the keys is pressed, and the corresponding state change is read by the 4700 in Test mode, it sends the appropriate code back to the 4600 to light the pressed key's LED. To the user, the two 4600 keys appear to behave in the same way as do other keys on the 4700.

End of Test

When the 4700 Test or Zero key is pressed, the 4700 addresses the Control Latch U108, and removes the latched TESTEN code from its output. The 4600 reverts to On/Off Sequence state R1, and awaits further programming from the 4700.

9.5 POWER SUPPLIES

9.5.1 Introduction

The Switch Mode Power Supply is described in *Section 9.3*, so no other description is given here.

The main inguard $\pm 15\text{V}$ supply and main outguard $+5\text{V}$ supply have their rectifiers and reservoir capacitors situated on the Front Panel PCB (*Circuit Diagram DC400792, Page 10.1-21*), next to the Mains Transformer, whose stub locates into a hole in the Front Panel PCB.

9.5.2 Line Power Distribution

Circuit Diagram DC400786 Sheet 2, Page 10.1-3 shows the main distribution of the 4600 power supplies.

Mains Input Module

(*Assembly Drawing DA400856, Page 10.2-15*)

This module is located on the left of the rear panel, (looking from behind the 4600). It is fitted with a voltage selector panel for use with the Mains Transformer, and a line fuse. Details of changing the line input voltage selection, and the required values of the fuse for different selections, are given in *Section 2 - Installation*. The module does not contain a filter, as a special input filter is fitted in the SMPS rectifier input, and the main supplies are input-filtered by the Mains Transformer. Connections to the module inside the 4600 are shown on the Assembly Diagram.

Local Ground Connection

It is **essential** to connect the local ground to the input cable (*refer to Section 2*). A sleeved 'earth' braid connects the incoming local ground to the instrument chassis. For other internal ground connections, see *Circuit Diagram DC400786 Sheet 2, Page 10.1-3*.

Power Switch

The line 'Live' is passed through the input module fuse, and both 'Live' and 'Neutral' are connected or isolated as a pair by the double-pole Power switch on the Front Panel. After switching, the line pair branches into two on the Front Panel PCB, both 'Live' lines being fused: one (P_LIVE and P_NEUT) passing back to the Input Module Voltage Selector PCB; the other (MAINS_L and MAINS_N) going to the SMPS Main PCB to drive the SMPS high-voltage rectifier. The automatic Line Voltage Detector for the SMPS is located on the Front Panel PCB to sense the input voltage level (*refer to Section 9.3.2 on Page 9.3-2*).

Mains (Line) Transformer

The primaries of the transformer are selected by the orientation of the Voltage Selector PCB in its external slot in the Input Module (*refer to Section 2 and Distribution Diagram DC400786 Sheet 2 Page 10.1-3 for details*). Transformer secondary windings are isolated by guard and ground electrostatic screens.

Three outputs are provided: 8VAC to drive the main outguard $+5\text{VDC}$ supply rectifier on the Front Panel PCB; 18V-0V-18V for the main inguard $\pm 15\text{VDC}$ supply rectifier (also on the Front Panel PCB); and 18V-0V-18V for the inguard $\pm 15\text{V}$ SMPS control supply (located on the SMPS Control PCB).

9.5.3 Outguard Power Supplies

Main $+5\text{V}$ Digital Power Supply

The 8V-0V AC output of the mains transformer is rectified by full-wave bridge D105 on the Front Panel PCB and passed to the Sense PCB, where the positive line is fused by F501 and regulated by U501 as $+5\text{V_REG}$. This supply is distributed to the opto-isolator outguard circuits as $+5\text{V_7}$, and to the main digital circuits and Overpower Detector as $+5\text{V_5}$; each having their own related commons. The regulator U501 has a power failure sensing output which is used in the instrument reset circuitry (*refer to Section 9.4.3 on Page 9.4-4*).

The $+5\text{V_5}$ is passed to the Front Panel PCB as FP_+5V to supply all LED cathodes except the green/red Psu LED. It also provides the supply for the ON and OFF keys, and the Line Voltage Selector MOSFET/relay RL101 circuit.

The 10V rectified unregulated line of this supply is used on the Front Panel PCB to power the Line Voltage Detector circuit (*refer to Sect. 9.3.2 on Page 9.3-2*). The green/red Psu indicator LED cathodes are taken to the 0V_RAW_OG common line on the Front Panel PCB.

9.5.4 Inguard Power Supplies

Main $+15\text{V}$ Analog Power Supply

The 18V-0V-18V AC output of the mains transformer is rectified by the full-wave bridge rectifier D104 on the Front Panel PCB and transferred as $+30\text{V}/0\text{V}/-30\text{V_RAW_IG}$ to the Sense PCB, where both positive and negative lines are fused by F502 and F503. Both lines are regulated (U502/U503) to $+15\text{V_REG}$ and -15V_REG . This supply is distributed to the opto-isolator inguard circuits, the relay driver and relays as $\pm 15\text{V_8}$, and to the Detector circuits and thermistor as $\pm 15\text{V_5}$; each having their own related commons.

The main supply to the Sense circuits has a separate star-point system ST2/ST3/ST4, with decoupling HF chokes inserted in the $\pm 15\text{V}$ lines. The $\pm 15\text{V_1}$ supply is distributed to the sense circuits from these star-points, with ST3 being used as a mecca.

Part of the Sense Amplifier is powered from a $\pm 6.8\text{V}$ supply, which has been further zener-regulated and smoothed from ST2/ST4 as $\pm 6\text{V8_1}$.

$\pm 15\text{V}$ SMPS Control Supply

The 18V-0V-18V AC output of the mains transformer is rectified by full-wave bridge D12 on the SMPS Control PCB and fused by F1 and F2. Both lines are regulated (M8/M9) to $+15\text{V_2}$ and -15V_2 . This supply is distributed to the SMPS control circuits, and passed to the SMPS Main PCB where each line is decoupled before being transferred to the Sense PCB as $\pm 15\text{V_OP}$. One of the inguard opto-coupler outputs (PSUEN) is also powered by $+15\text{V_2}$ to eliminate circulating currents.

In the Sense PCB the $\pm 15\text{V_OP}$ supply is used to power the Autobias sensors; it is also transferred to the Output PCB to supply the Input Buffer and the Autobias constant-current source.



GALs U105, U204 and U206 - Transfer Functions

Appendix 1 to:
4600 User's Handbook
Section 9

U105 Decoder - Address and Command Decodes

1 = High; 0 = Low; x = 1 or 0 U105 pin numbers shown in *italics*

Address Decodes

A4 (9)	A3 (8)	A2 (7)	A1 (6)	A0 (5)	A_H_D_L (2)	WR_R (4)	RD_L (3)	POR_L (11)	CK_BUSON_L (1)	Decode Address Name	Chip(s) Selected
0	0	0	0	1	0	0	1	1	x	W01_L (15)	U108/U109
0	0	0	0	0	0	1	0	1	x	R00_L (14)	U106
0	0	0	0	1	0	1	0	1	x	R01_L (16)	U110
0	0	0	1	0	0	1	0	1	x	R02_L (17)	U111
0	0	1	1	0	0	1	0	1	x	R03_L (18)	U112

Command Decodes

A4 (9)	A3 (8)	A2 (7)	A1 (6)	A0 (5)	A_H_D_L (2)	WR_R (4)	RD_L (3)	POR_L (11)	CK_BUSON_L (1)	Decode Group Name
x	x	x	x	x	x	x	x	0	x	Power On
x	x	x	x	x	1	0	1	x	x	Latch Address into U104
0	0	0	0	1	0	0	1	1	x	Write Data to Address W01
0	0	0	x	x	0	1	0	1	x	Send Read Data to Interface
x	x	x	x	x	1	1	1	1	x	Deselected, No Read or Write
x	x	x	x	x	1	0	0	1	0	Encoded Reset

Command Decodes - Grouped Outputs

Decode Group Name	LTAD_R (12)	SDATA_H (13)	RST_L (19)	W01_L (15)	R00_L (14)	R01_L (16)	R02_I (17)	R03_L (18)
Power On	x	0	0	1	1	1	1	1
Latch Address into U104	0	0	1	1	1	1	1	1
Write Data to Address W01	1	0	1	0	1	1	1	1
Send Read Data to Interface	1	1	1	1	x	x	x	x
Deselected, No Read or Write	1	0	1	1	1	1	1	1
Encoded Reset	1	0	0	1	1	1	1	1

U204 Clocked Transfer Functions - Logic Diagrams

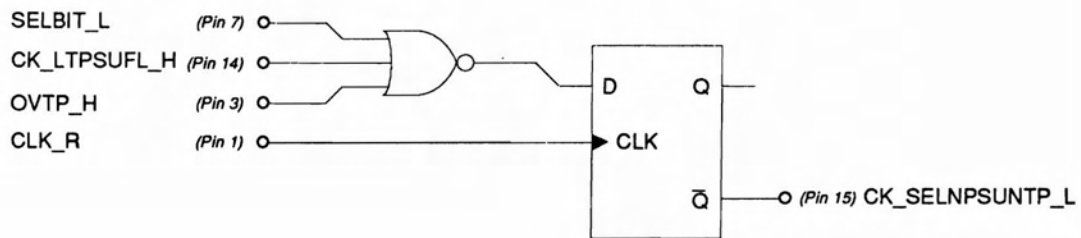
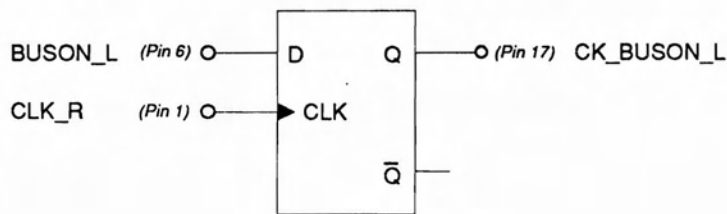
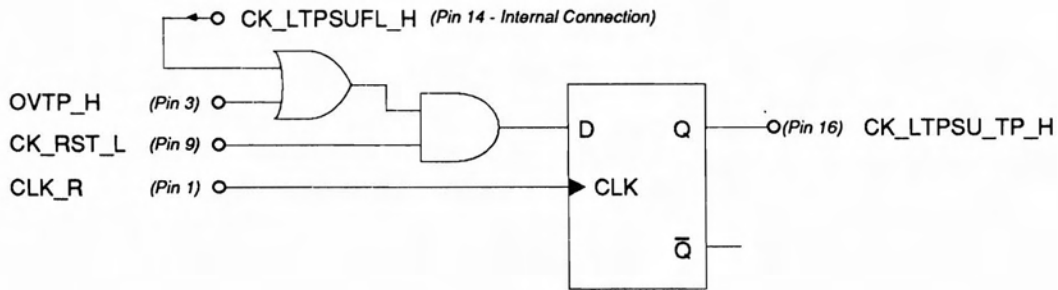
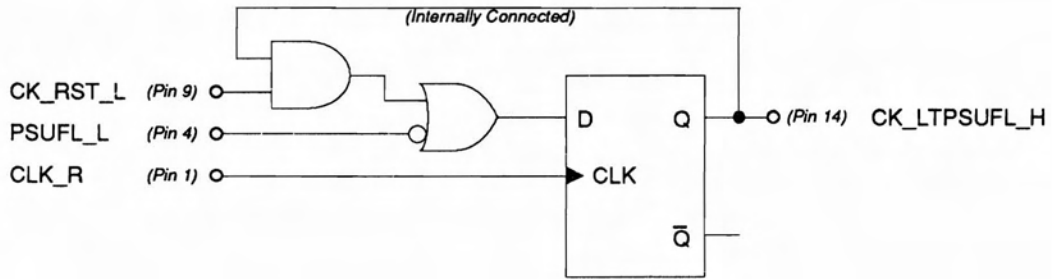

U204 Combination Transfer Functions - Logic Diagrams

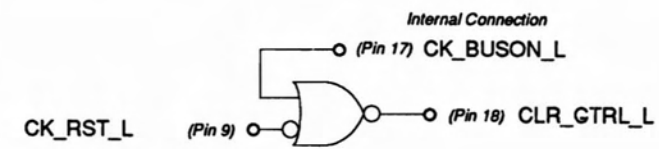
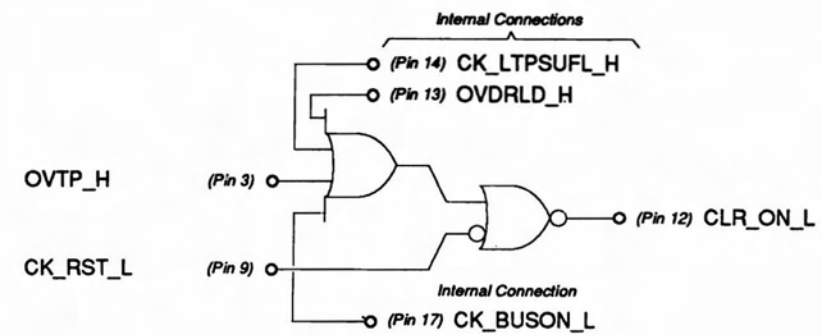
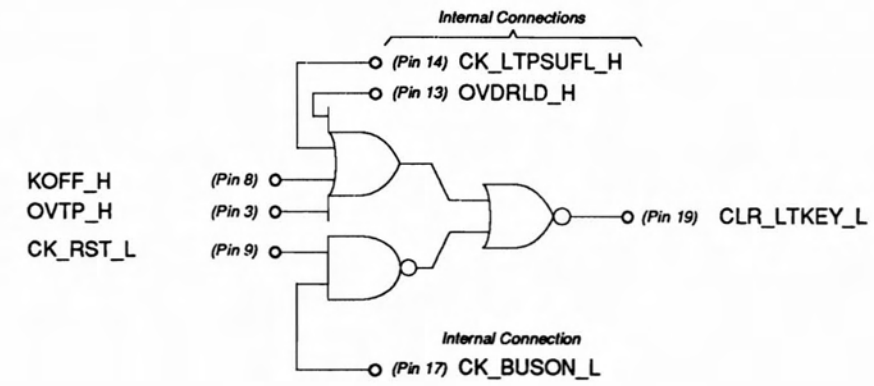
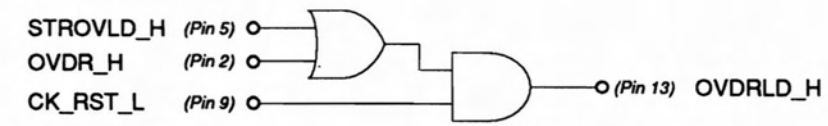

Output On and Off Sequence Tables

Slave

Activation

U206 Output State to be Entered	Previous Established State	Conditional states referred to U206 input at the time U206 is clocked	Resulting U206 Output States after U206 clock							
			SOLO {19'}	SOLOLED {12'}	PSUEN {18'}	OPON {17'}	OPOC {16'}	IPON {15'}	OFF {14'}	ON {13'}
R1	Power On Any Other state Solo S1 or S2	----- CK_RST {9'} true CK_BUSON {2'} true	F	F	F	F	F	F	T	F
R2	R1	CK_BUSON {2'} true and CK_(SELBIT true and LTPSUFL false and OVTP false) {4'} true	F	F	T	F	F	F	T	F
R3	R2	CK_ONBIT {7'} true and CK_PODLY {5'} false and CK_(SELBIT true and LTPSUFL false and OVTP false) {4'} true	F	F	T	T	F	F	F	F
R4	R3	CK_ONBIT {7'} true	F	F	T	T	T	F	F	F
R5	R4	CK_ONBIT {7'} true	F	F	T	T	T	T	F	T

De-activation

U206 Output State to be Entered	Previous Established State	Conditional states referred to U206 input at the time U206 is clocked	Resulting U206 Output States after U206 clock							
			SOLO {19'}	SOLOLED {12'}	PSUEN {18'}	OPON {17'}	OPOC {16'}	IPON {15'}	OFF {14'}	ON {13'}
R5	-----	(State achieved during activation)	F	F	T	T	T	T	F	T
R4	R5	CK_ONBIT {7'} false	F	F	T	T	T	F	F	F
R3	R4	CK_ONBIT {7'} false	F	F	T	T	F	F	F	F
R2	R3	CK_ONBIT {7'} false	F	F	T	F	F	F	T	F
R1	R2	CK_(SELBIT true and LTPSUFL false and OVTP false) {4'} false	F	F	F	F	F	F	T	F

Notes:

Input TESTEN_L turns off SOLOLED_L, OFF_L and ON_L so that they are driven by LED test.

Sequencer U206 pin numbers in curly braces.

Solo**Activation**

U206 Output State to be Entered	Previous Established State	Conditional states referred to U206 input at the time U206 is clocked	Resulting U206 Output States after U206 clock							
			SOLO {19'}	SOLOLED {12'}	PSUEN {18'}	OPON {17'}	OPOC {16'}	IPON {15'}	OFF {14'}	ON {13'}
S1	Remote R1	CK_BUSON {2'} false and CK_(LTPSUFL false and OVTP false) {3'} false	T	T	F	F	F	F	T	F
S2	Remote R1 or Solo S1	CK_BUSON {2'} false and CK_(LTPSUFL false and OVTP false) {3'} true	T	T	T	F	F	F	T	F
S3	S2	CK_BUSON {2'} false and CK_(LTPSUFL false and OVTP false) {3'} true and CK_LTKEY {6'} true and CK_PODLY {5'} false	T	T	T	T	F	F	F	F
S4	S3	CK_LTKEY {6'} true	T	T	T	T	T	F	F	F
S5	S4	CK_LTKEY {6'} true	T	T	T	T	T	T	F	T

De-activation

U206 Output State to be Entered	Previous Established State	Conditional states referred to U206 input at the time U206 is clocked	Resulting U206 Output States after U206 clock							
			SOLO {19'}	SOLOLED {12'}	PSUEN {18'}	OPON {17'}	OPOC {16'}	IPON {15'}	OFF {14'}	ON {13'}
S5	----	(State achieved during activation)	T	T	T	T	T	T	F	T
S4	S5	CK_LTKEY {6'} false	T	T	T	T	T	F	F	F
S3	S4	CK_LTKEY {6'} false	T	T	T	T	F	F	F	F
S2	S3	CK_LTKEY {6'} false	T	T	T	F	F	F	T	F
S1	S2	CK_(LTPSUFL false and OVTP false) {3'} false	T	T	F	F	F	F	T	F

Notes:

Input TESTEN_L turns off SOLOLED_L, OFF_L and ON_L so that they are driven by LED test.

Sequencer U206 pin numbers in curly braces.



SECTION 10 Servicing Diagrams and Parts Lists

Contents of this Section

10.1 Circuit Diagrams and Component Layouts

Interconnection Diagrams	10.1-2
Sense PCB	10.1-4
Output PCB	10.1-14
SMPS Main PCB	10.1-16
SMPS Control PCB	10.1-18
Front PCB	10.1-20

10.2 Assembly Diagrams and Parts Lists

(The Parts List for each assembly is generally placed immediately behind its assembly diagrams)

Finished Assembly	10.2-2
Instrument Assembly	10.2-5
Top Cover	10.2-11
Bottom Cover	10.2-12
Mains Transformer	10.2-13
Handle	10.2-14
Rear Panel	10.2-15
Sense PCB	10.2-17
Output PCB	10.2-19
SMPS Main PCB	10.2-21
SMPS Control PCB	10.2-23
Front PCB	10.2-25
Analog Bus Cable	10.2-27
Digital Bus Cable	10.2-28
Output Lead Kit	10.2-29

10.1 Circuit Diagrams and Component Layouts

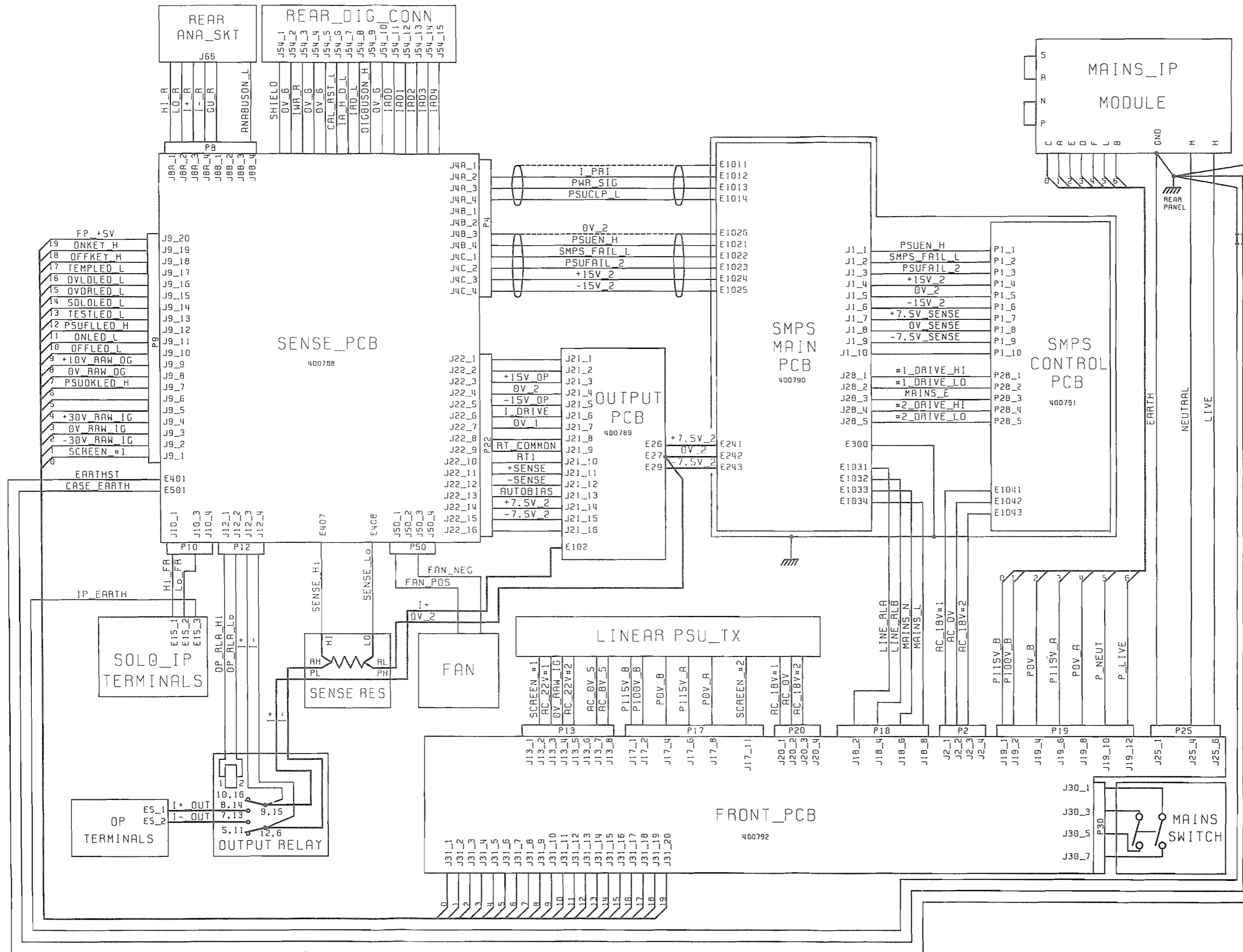

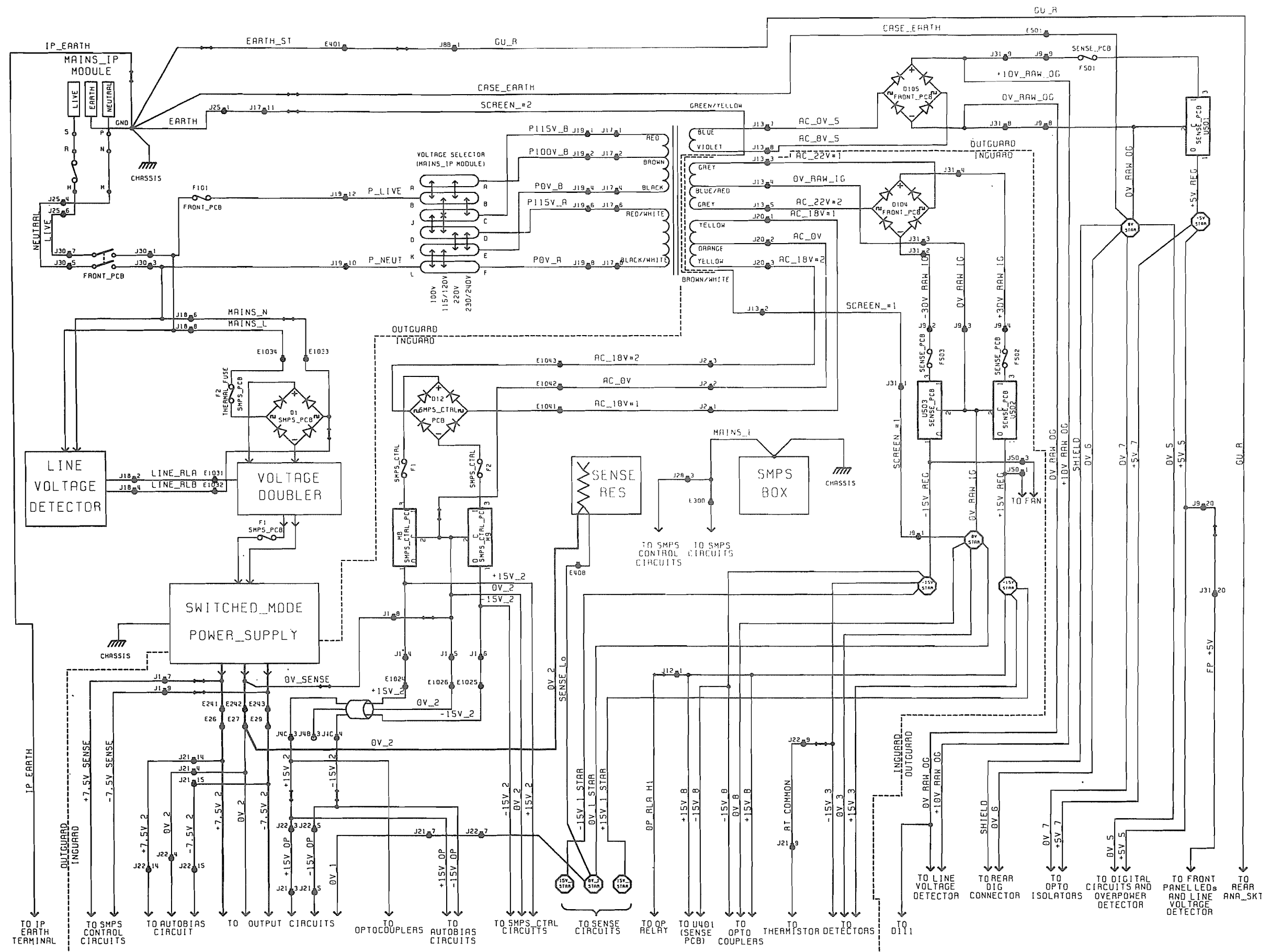

INTERCONNECTION DIAGRAM
Power Distribution
 Drawing No. DC400786 Sheet 2

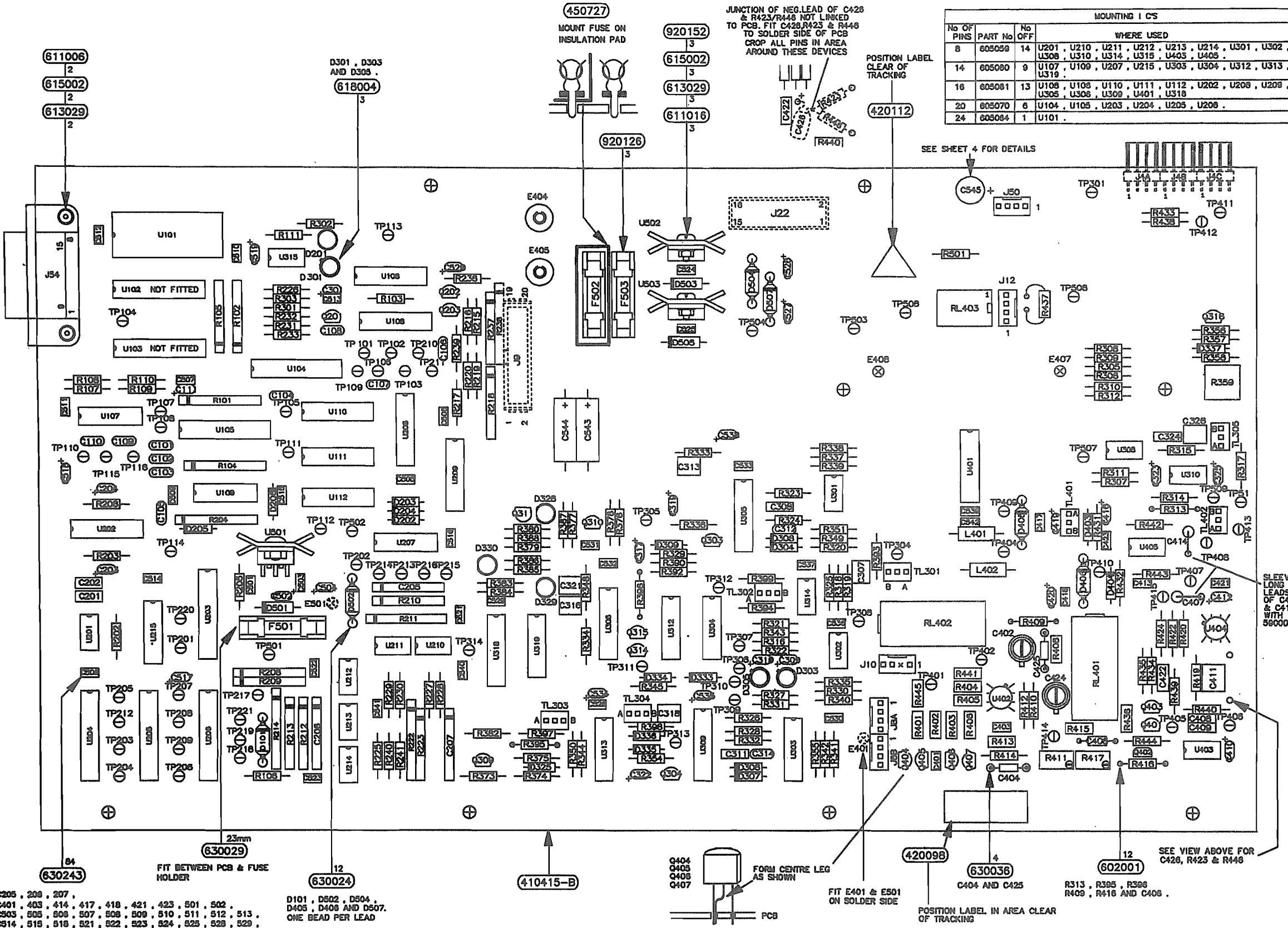

MOUNTING I CS

No OF PINS	PART No	No OFF	WHERE USED
8	605058	14	U201, U210, U211, U212, U213, U214, U301, U302, U308, U310, U314, U315, U403, U408.
14	605080	9	U107, U108, U207, U215, U303, U304, U312, U313, U319.
16	605081	13	U108, U108, U110, U111, U112, U202, U208, U209, U305, U306, U309, U401, U318.
20	605070	6	U104, U105, U203, U204, U205, U206.
24	605084	1	U101.

JUNCTION OF NEG. LEAD OF C428 & R423/R448 NOT LINKED TO PCB. FIT C428, R423 & R448 TO SOLDER SIDE OF PCB. CROP ALL PINS IN AREA AROUND THESE DEVICES

SEE SHEET 4 FOR DETAILS

SLEEVE LONG LEADS OF C407 & C414 WITH 590004

C205, 209, 207, C401, 403, 414, 417, 418, 421, 423, 501, 502, C503, 505, 506, 507, 508, 509, 510, 511, 512, 513, C514, 515, 516, 521, 522, 523, 524, 525, 528, 529, C530, 531, 532, 533, 536, 537, 539, 540, 541, 542.
ONE BEAD PER LEAD

D101, D502, D504, D405, D406 AND D507.
ONE BEAD PER LEAD

4600
datron
INSTRUMENTS

SENSE PCB
Component Layout

© Datron Instruments 1988 Drawing No. DA400788 Sheet 1

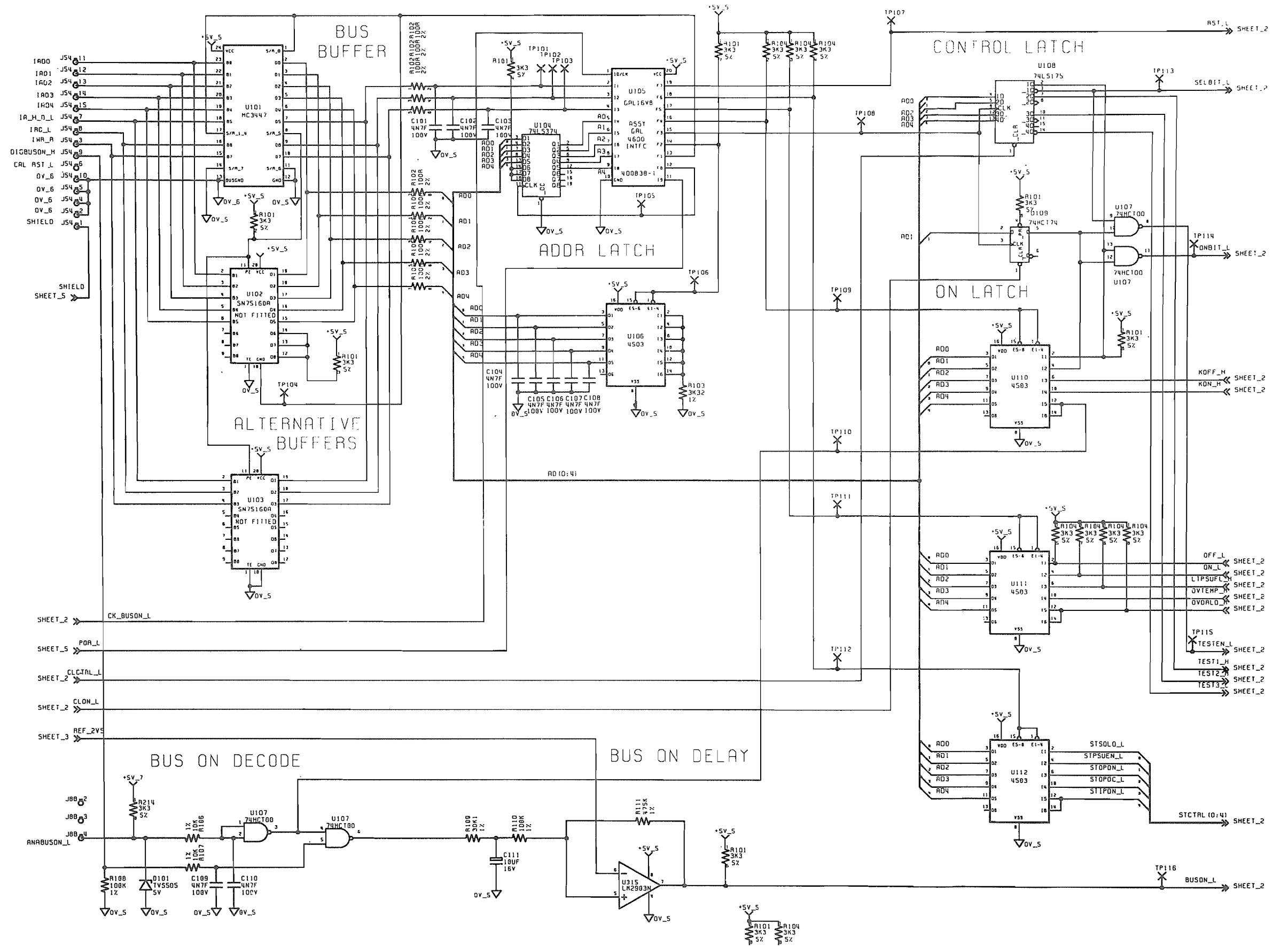

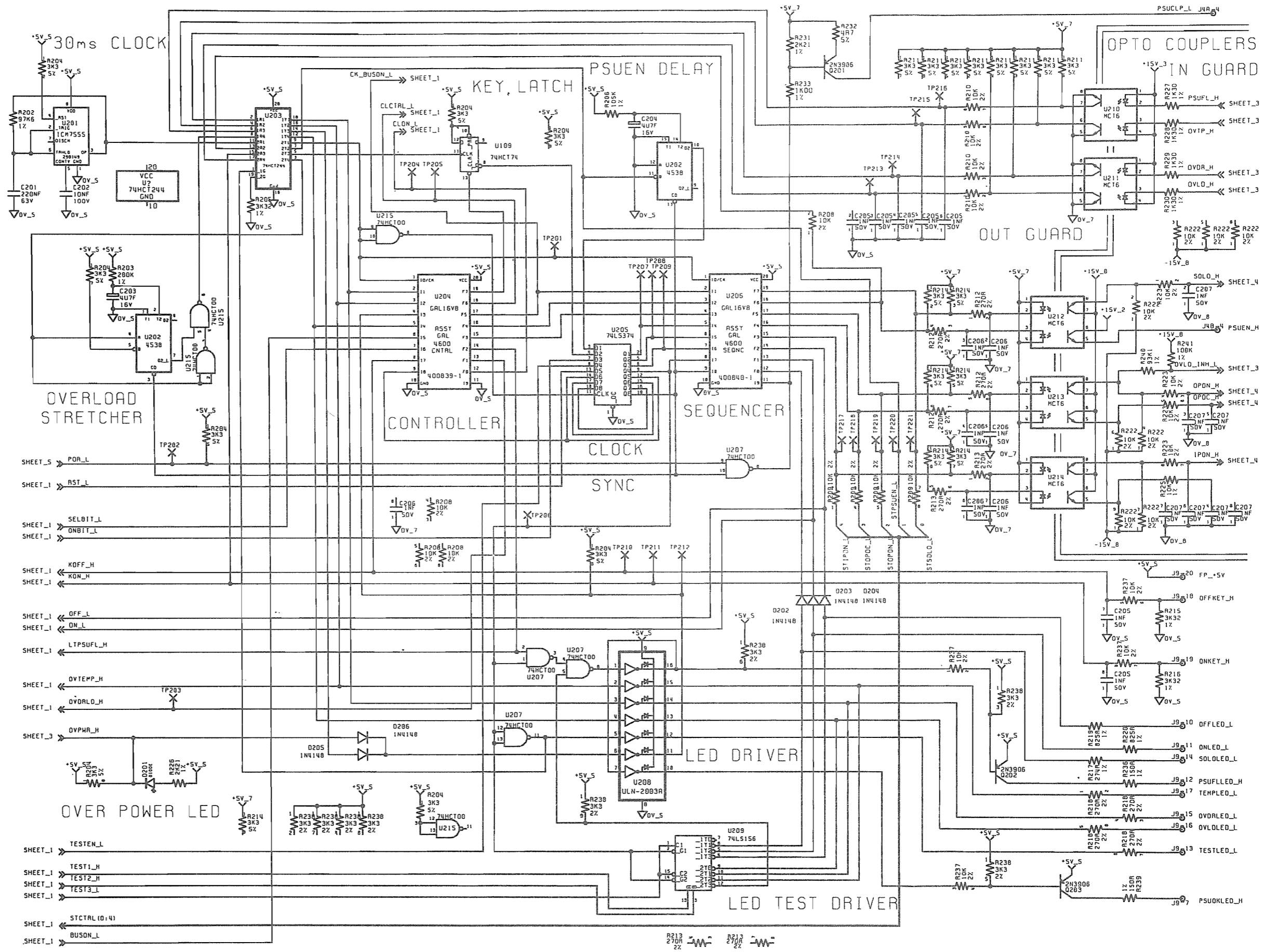

MOUNTING I C'S		
No OF PINS	PART No	No OFF
8	605059	14
14	605080	9
16	605081	13
20	605070	8
24	605084	1

WHERE USED
 U201, U210, U211, U212, U213, U214, U301, U302, U308, U310, U314, U315, U403, U405.
 U107, U109, U207, U215, U303, U304, U312, U313, U319.
 U108, U109, U110, U111, U112, U202, U208, U209, U305, U309, U401, U318.
 U104, U105, U203, U204, U205, U206.
 U101.

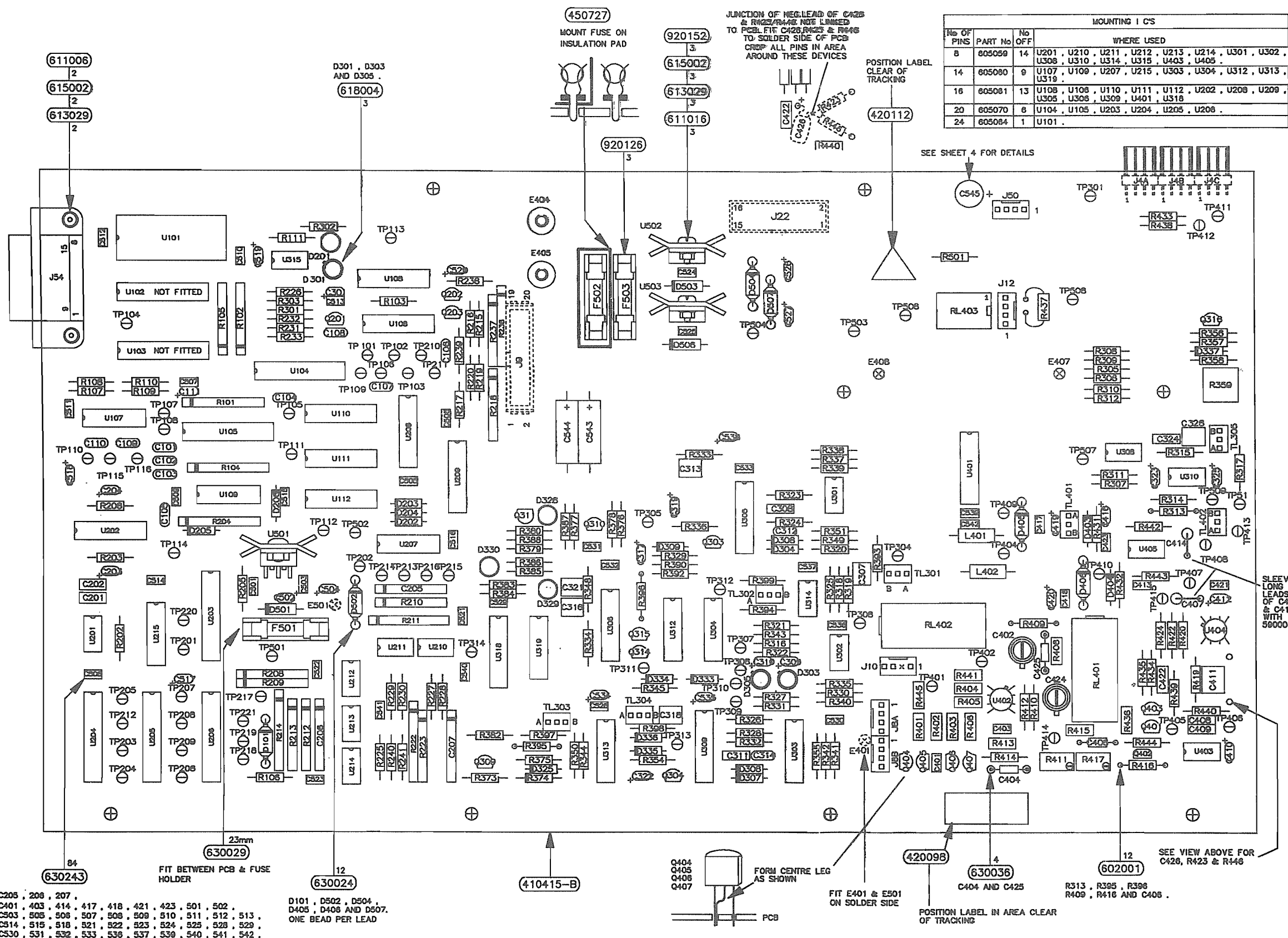

C205, 206, 207,
 C401, 403, 414, 417, 418, 421, 423, 501, 502,
 C503, 505, 508, 507, 508, 509, 510, 511, 512, 513,
 C514, 515, 518, 521, 522, 523, 524, 525, 528, 529,
 C530, 531, 532, 533, 536, 537, 539, 540, 541, 542.
 ONE BEAD PER LEAD

D101, D502, D504,
 D405, D408 AND D507.
 ONE BEAD PER LEAD

410415-B

Q404
 Q405
 Q406
 Q407

420098
 630036
 C404 AND C425

602001
 R313, R395, R396
 R409, R416 AND C408.

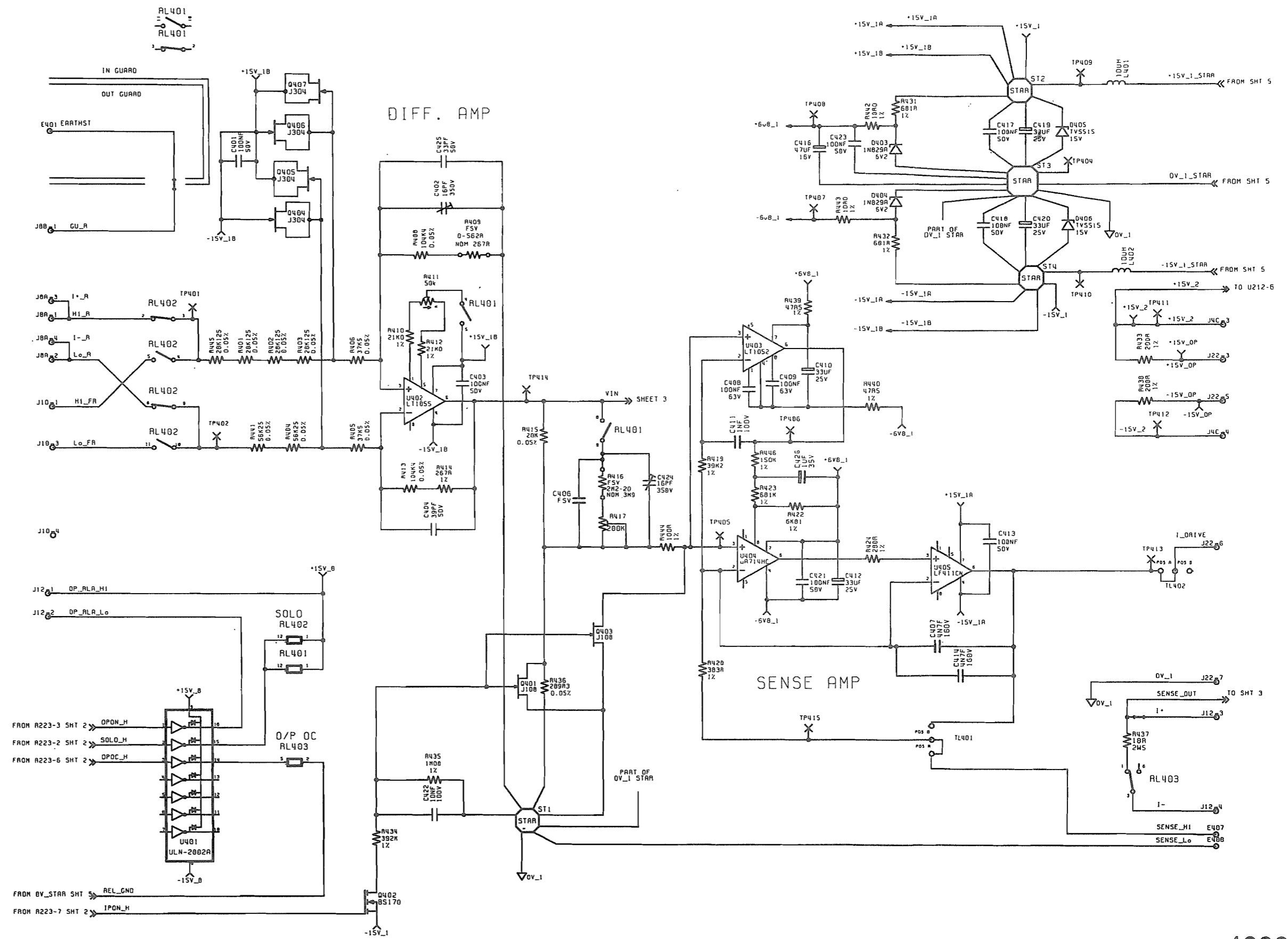

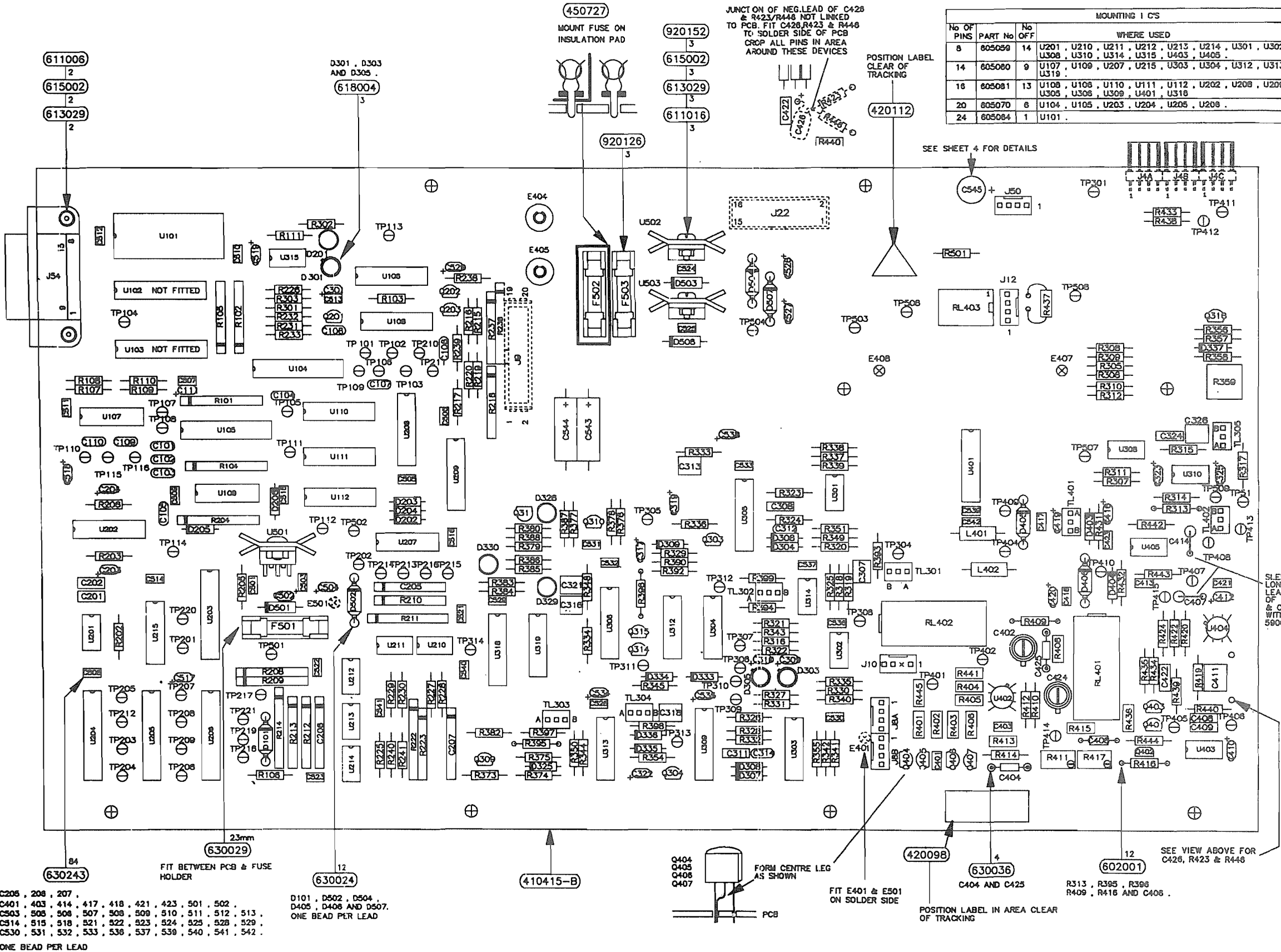

MOUNTING I CS			
No OF PINS	PART No	No OFF	WHERE USED
8	605059	14	U201, U210, U211, U212, U213, U214, U301, U302, U308, U310, U314, U315, U403, U405.
14	605060	9	U107, U109, U207, U215, U303, U304, U312, U313, U319.
16	605081	13	U108, U108, U110, U111, U112, U202, U208, U209, U305, U306, U309, U401, U318.
20	605070	6	U104, U105, U203, U204, U205, U208.
24	605084	1	U101.

C206, 208, 207,
 C401, 403, 414, 417, 418, 421, 423, 501, 502,
 CS43, 508, 508, 507, 508, 509, 510, 511, 512, 513,
 CS14, 515, 518, 521, 522, 523, 524, 525, 528, 529,
 CS30, 531, 532, 533, 536, 537, 538, 540, 541, 542.
 ONE BEAD PER LEAD

D101, D502, D504,
 D405, D406 AND D507.
 ONE BEAD PER LEAD

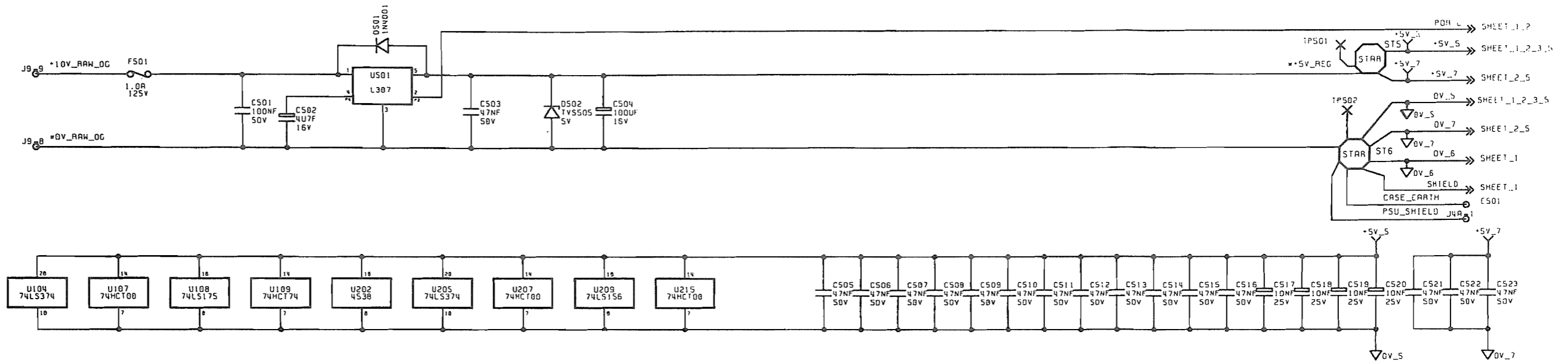

OUT GUARD

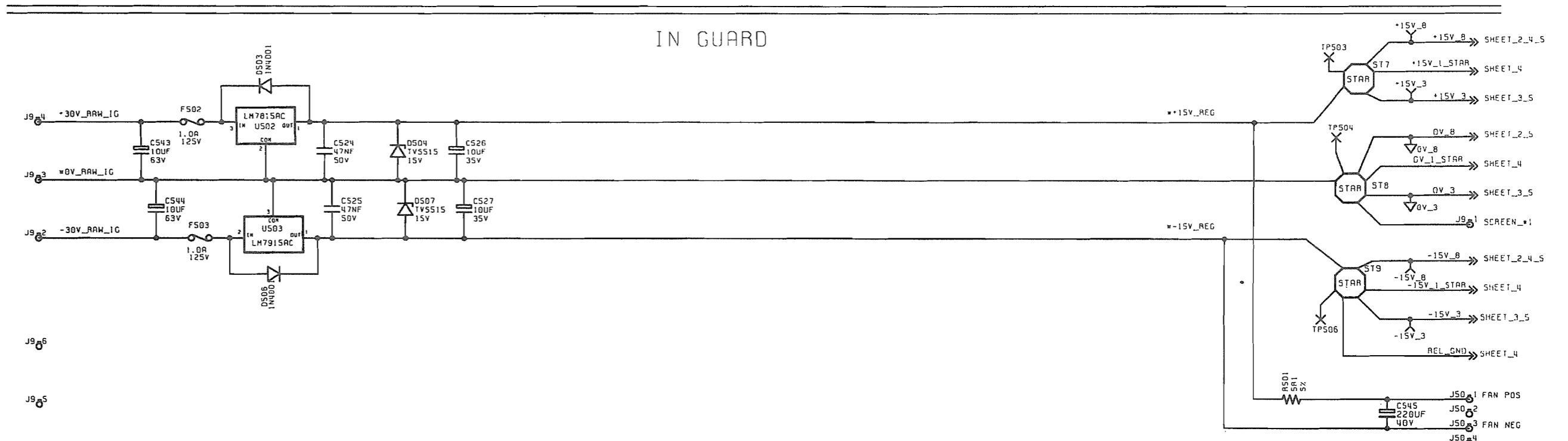

IN GUARD

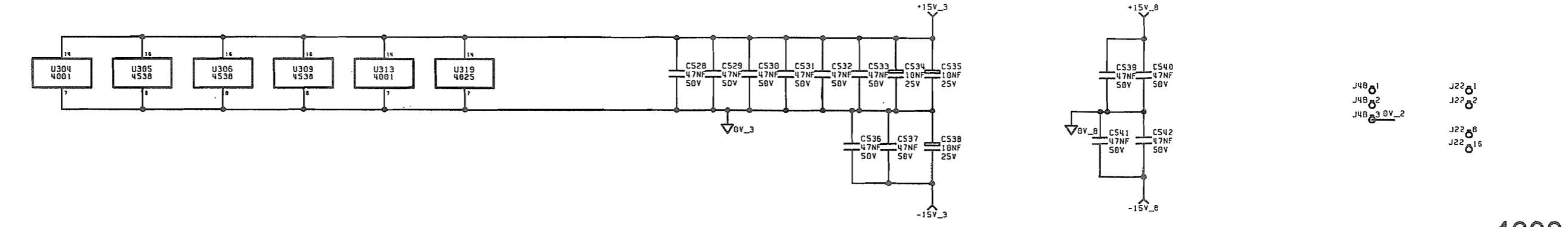

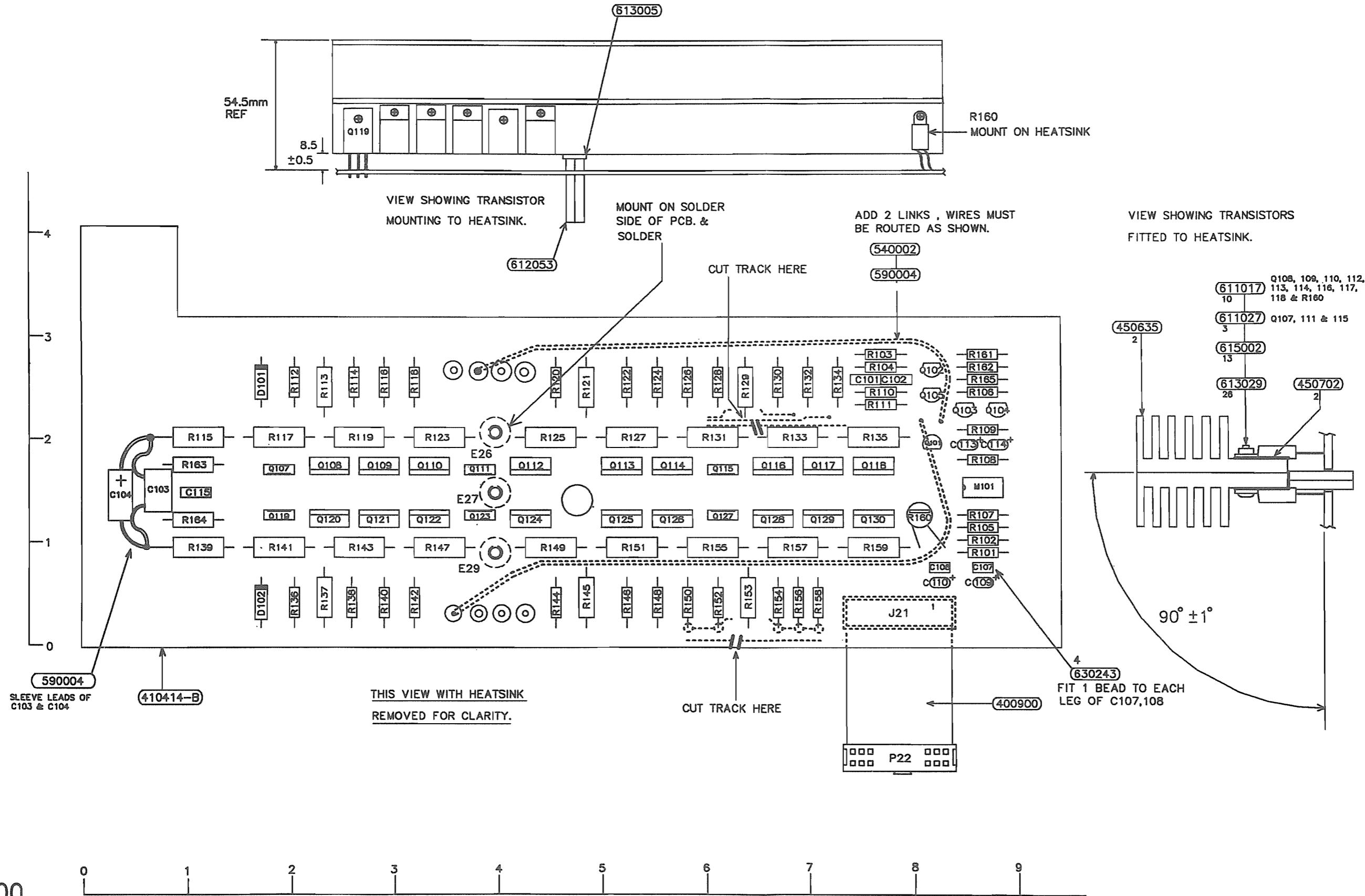

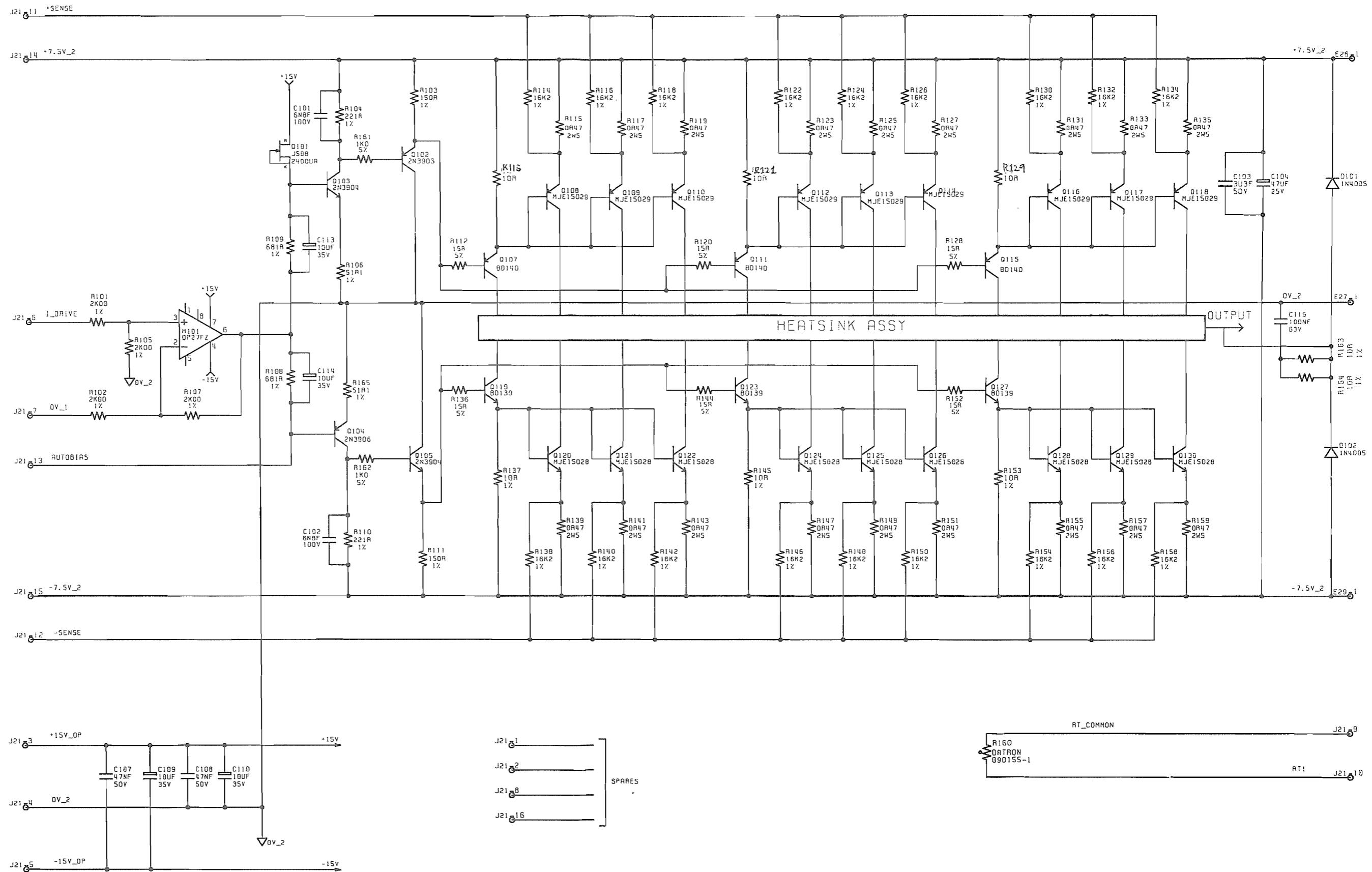

**OUTPUT PCB
Circuit Diagram**

Drawing No. DC400789

Sheet 1



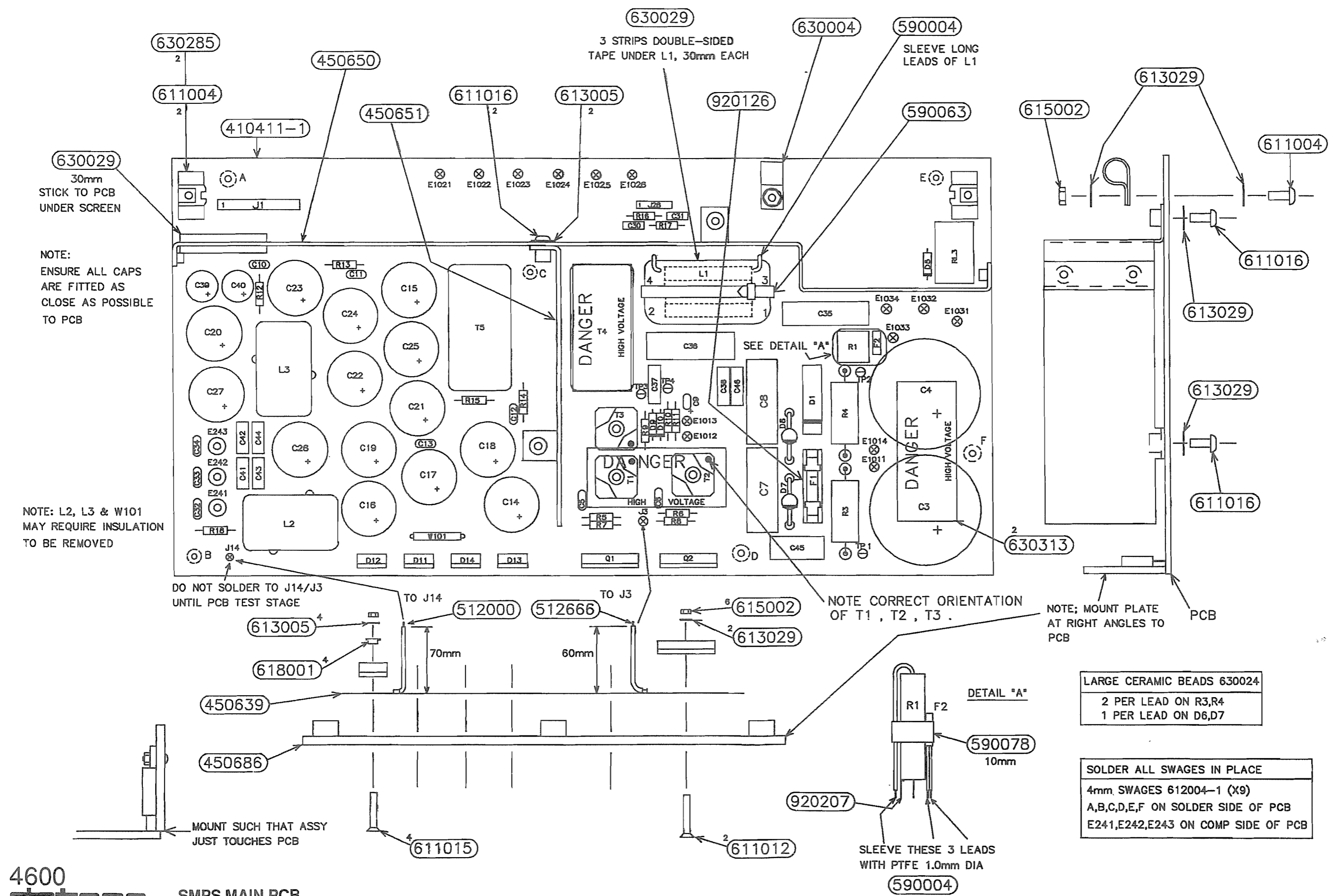

630029
 30mm
 STICK TO PCB
 UNDER SCREEN

NOTE:
 ENSURE ALL CAPS
 ARE FITTED AS
 CLOSE AS POSSIBLE
 TO PCB

NOTE: L2, L3 & W101
 MAY REQUIRE INSULATION
 TO BE REMOVED

DO NOT SOLDER TO J14/J3
 UNTIL PCB TEST STAGE

NOTE CORRECT ORIENTATION
 OF T1, T2, T3.

NOTE; MOUNT PLATE
 AT RIGHT ANGLES TO
 PCB

MOUNT SUCH THAT ASSY
 JUST TOUCHES PCB

SLEEVE THESE 3 LEADS
 WITH PTFE 1.0mm DIA

LARGE CERAMIC BEADS 630024
 2 PER LEAD ON R3,R4
 1 PER LEAD ON D6,D7

SOLDER ALL SWAGES IN PLACE
 4mm SWAGES 612004-1 (X9)
 A,B,C,D,E,F ON SOLDER SIDE OF PCB
 E241,E242,E243 ON COMP SIDE OF PCB

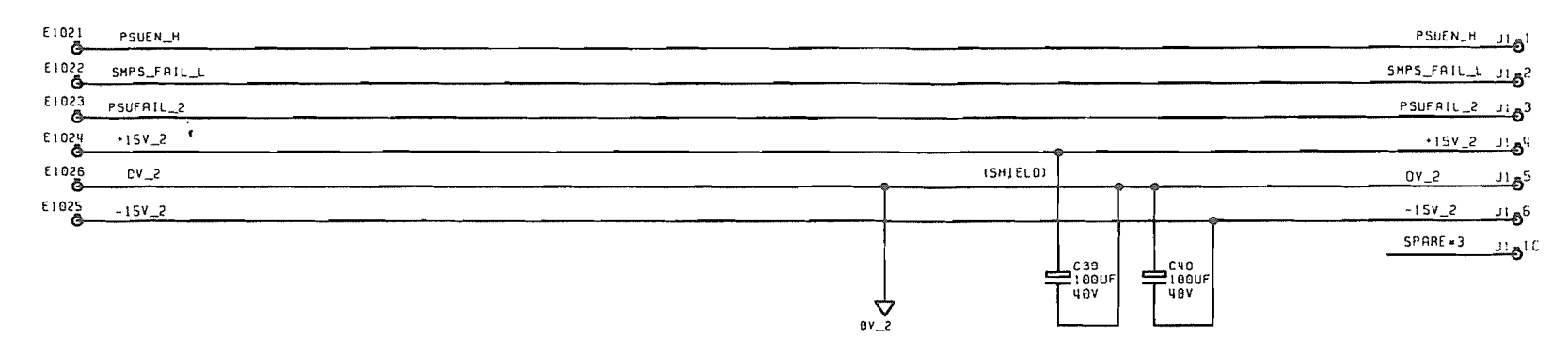
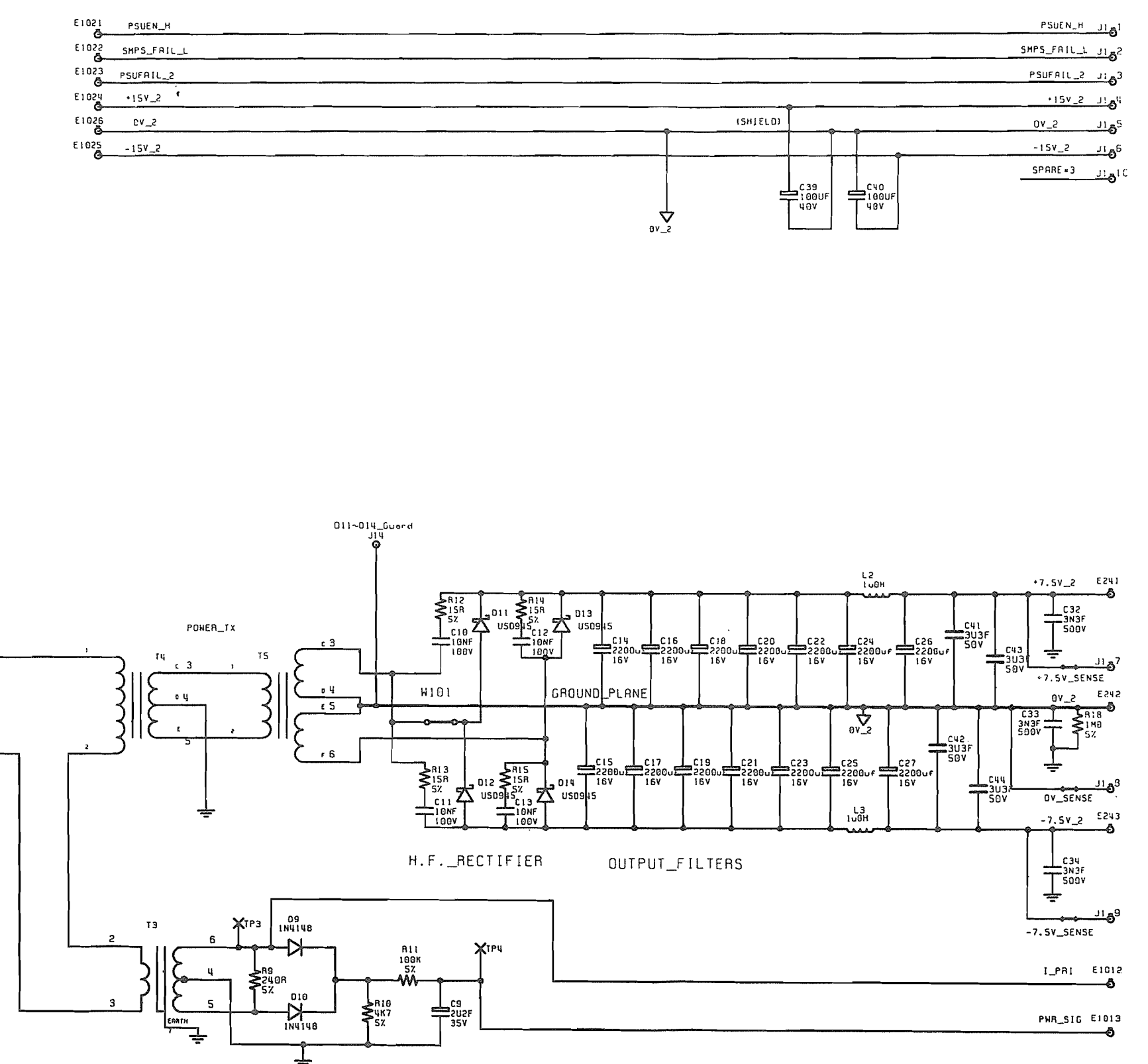
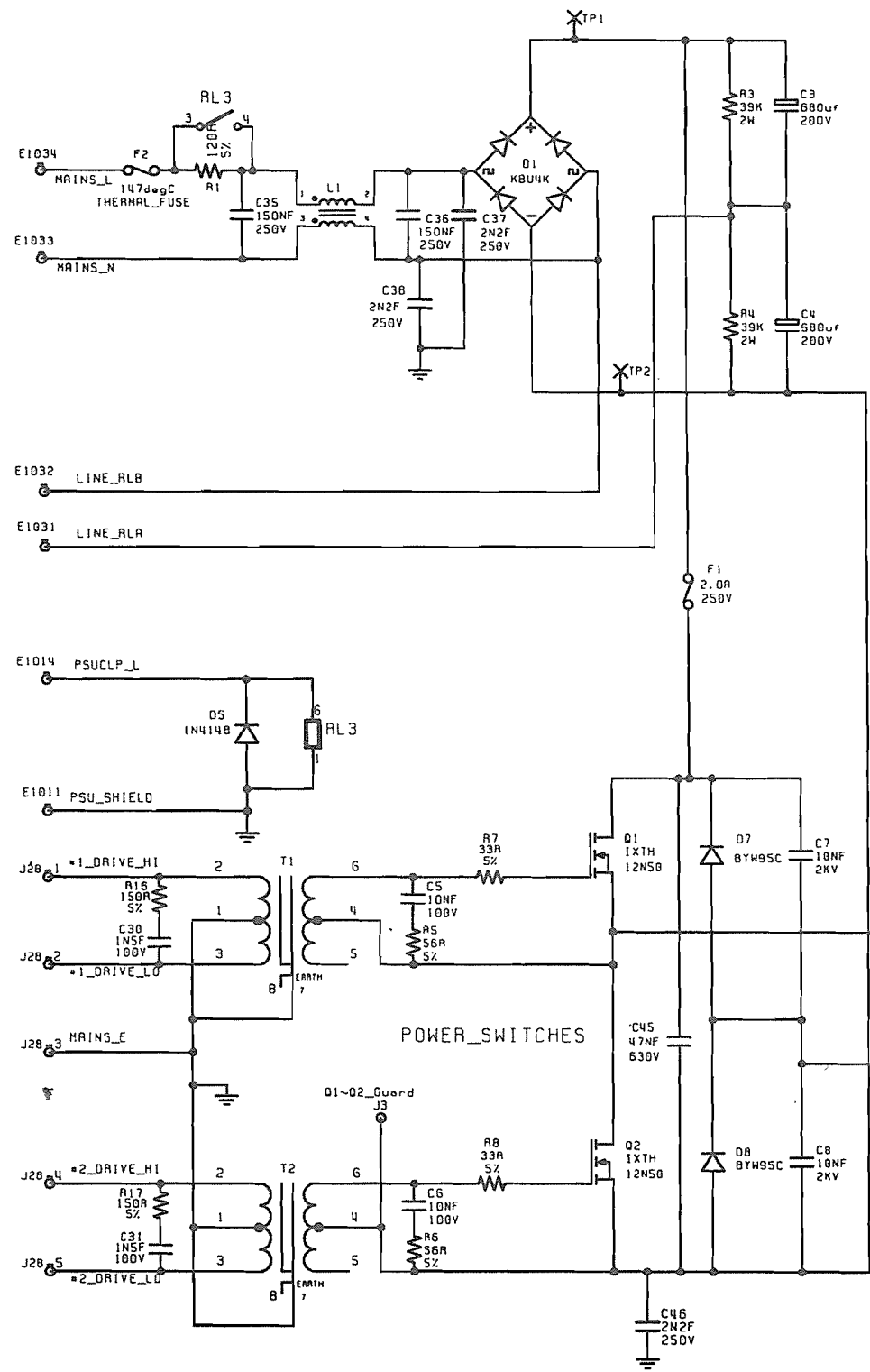

CURRENT_MONITOR

SMPS MAIN PCB
Circuit Diagram

Drawing No. DC400790 Sheet 1

4600
datron
INSTRUMENTS
© Datron Instruments 1988

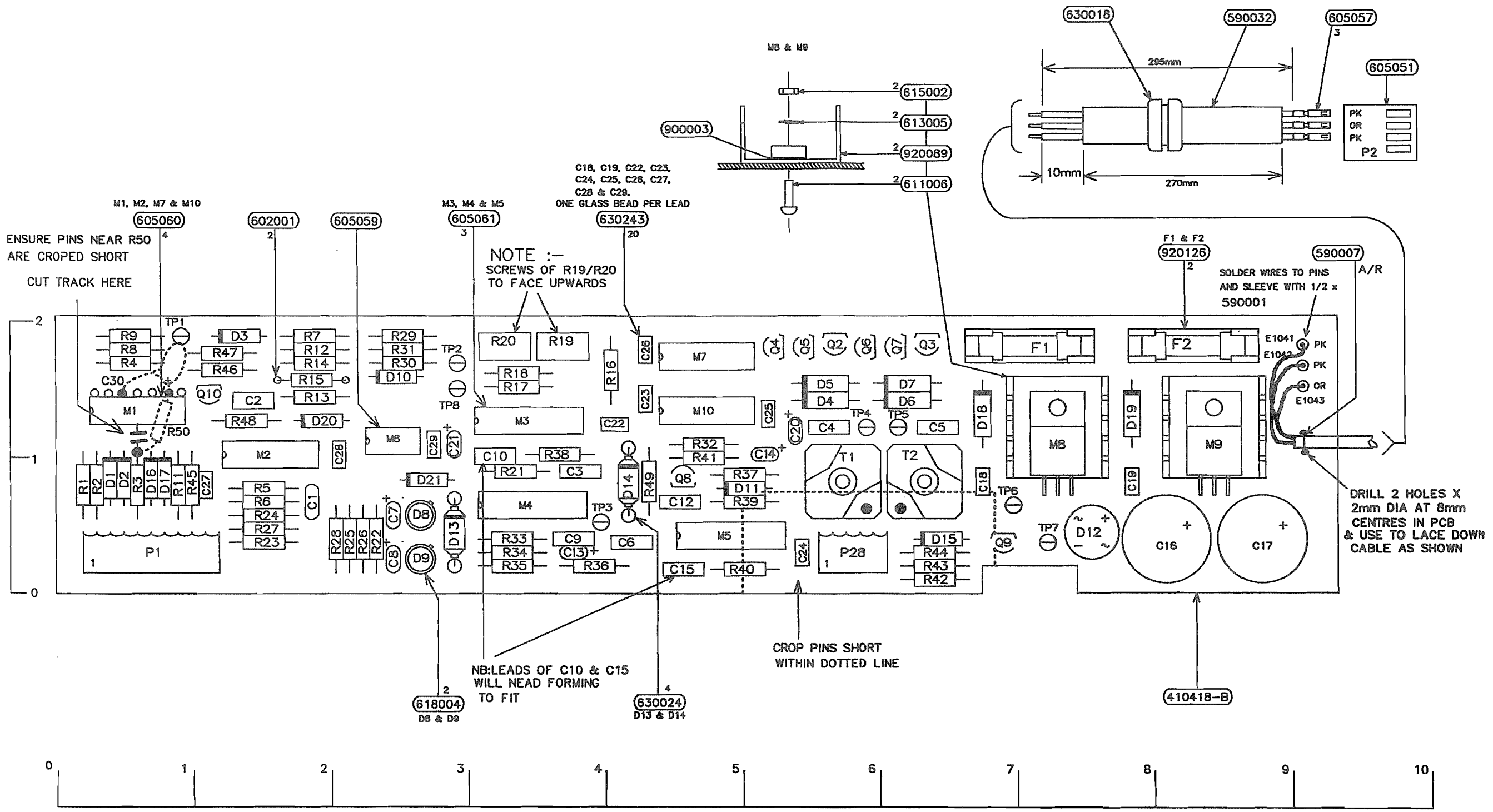

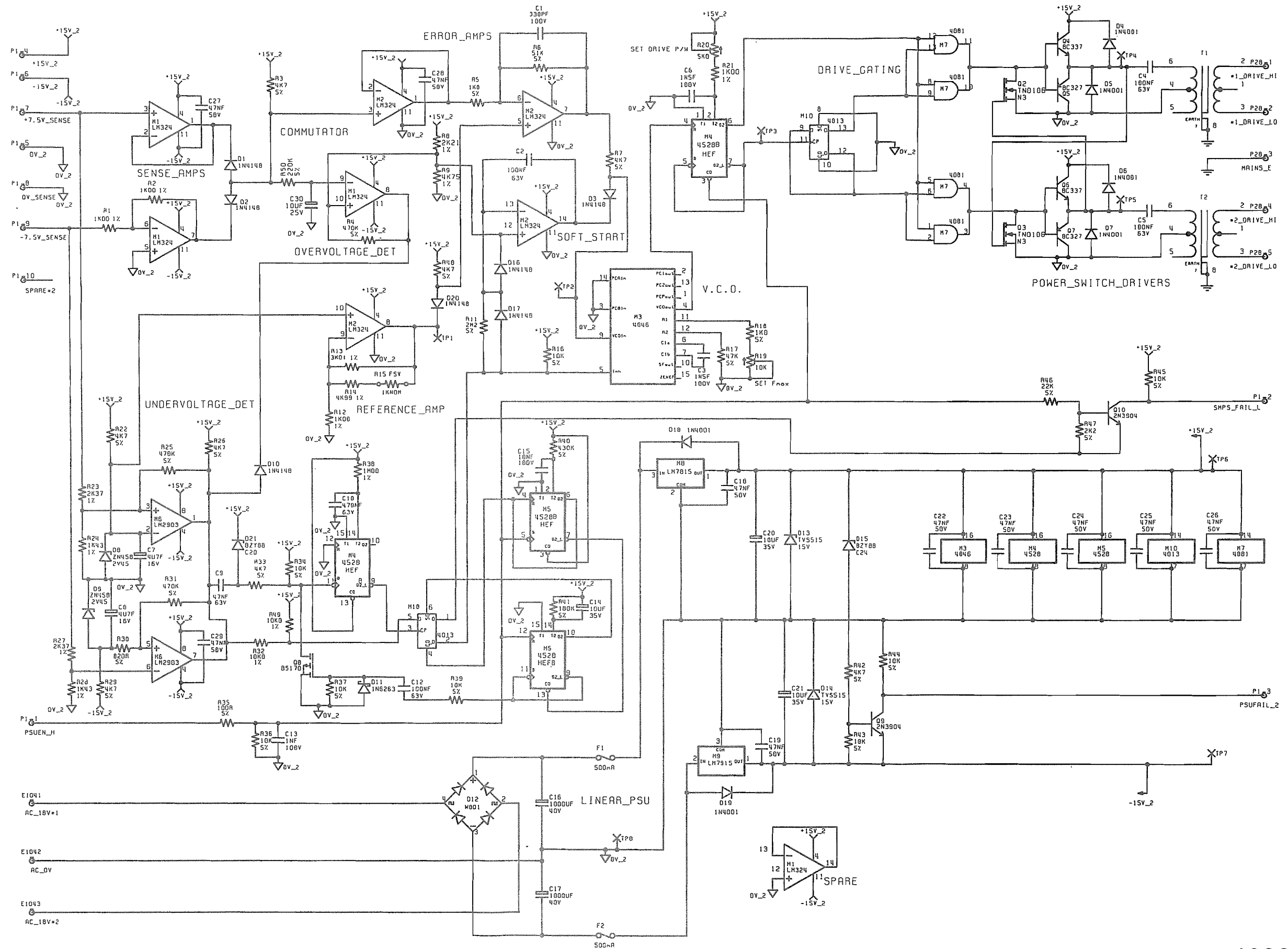

SMPS CONTROL PCB
Circuit Diagram
Drawing No. DC400791

DRILL HOLE 0.8mm DIA
WHERE INDICATED AT
"A". (SOLDER SIDE OF
PCB SHOWN)
FIT WIRE LINK (540001)
BETWEEN "A" AND PAD
"B" AFTER FITTING RL101

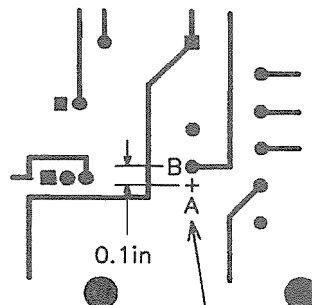

420098

630309

MOUNT D106-D110 ON
GLASS BEADS (630243)
1 PER LEG

REMOVE PINS
SHOWN '•'

MOUNT THESE COMPONENTS ON
THE SOLDER SIDE OF THE PCB
D106 - D111, S102, S103.

920126

SOLDER SIDE

410410-B

U101 MUST BE SOLDERED
DIRECTLY INTO PCB

WIRES : RED & BLACK = 45mm
BLUE & BROWN = 50mm

Q101 -
JOINED LEG
AT "D"

FIT P30 TO J30
WHEN SWITCH IS
SCREWED TO PCB

400899

611011

615006

613014

613012

SLEEVE EACH JOINT
1/2 X 590001

605052

605057 4OFF

4600
datron
INSTRUMENTS

FRONT PCB
Component Layout

© Datron Instruments 1988

Drawing No. DA400792 Sheet 1

10.1-20

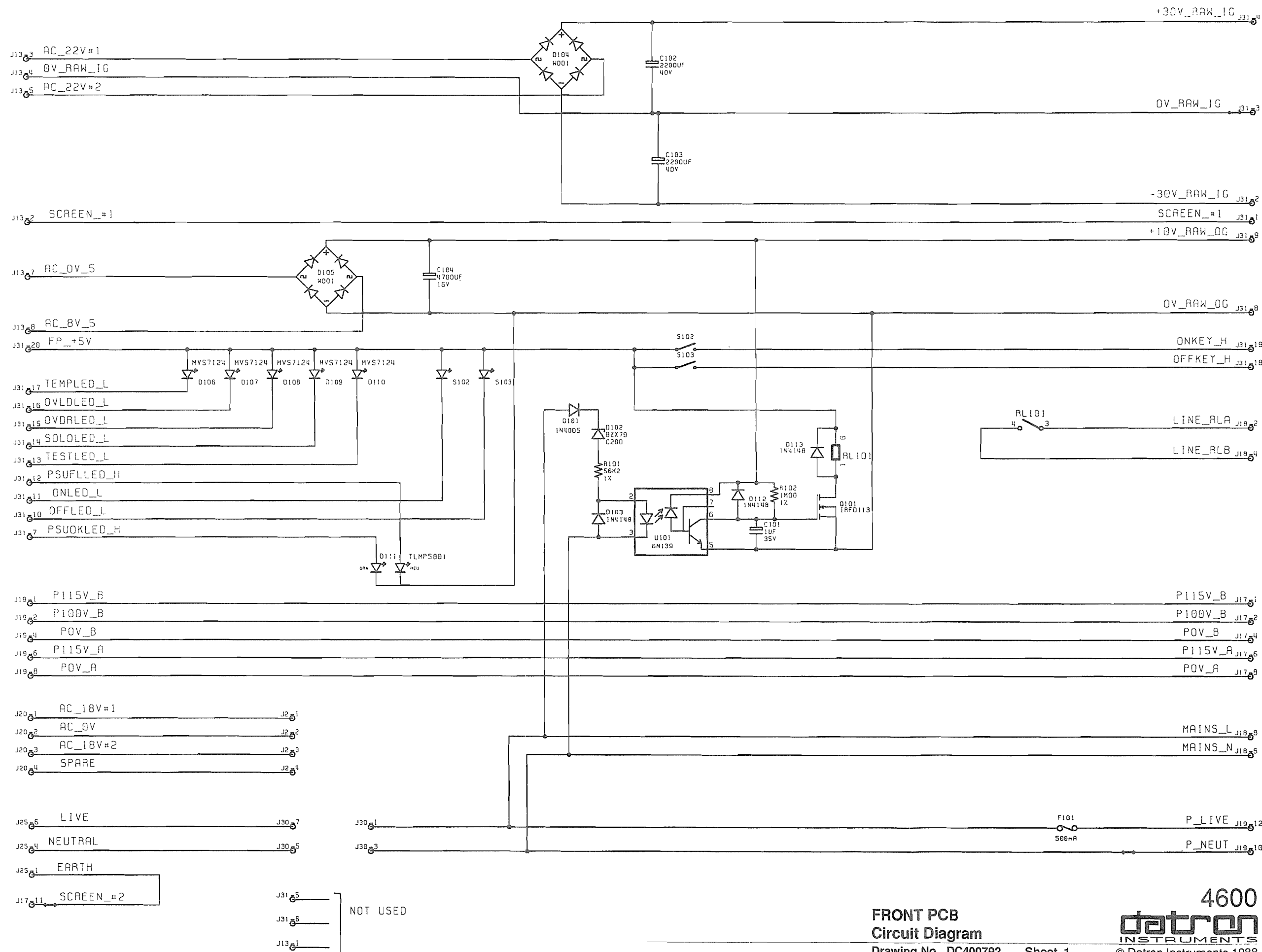

FRONT PCB
Circuit Diagram

Drawing No. DC400792 Sheet 1

4600
datron
INSTRUMENTS
© Datron Instruments 1988



10.2 Assembly Diagrams and Parts Lists

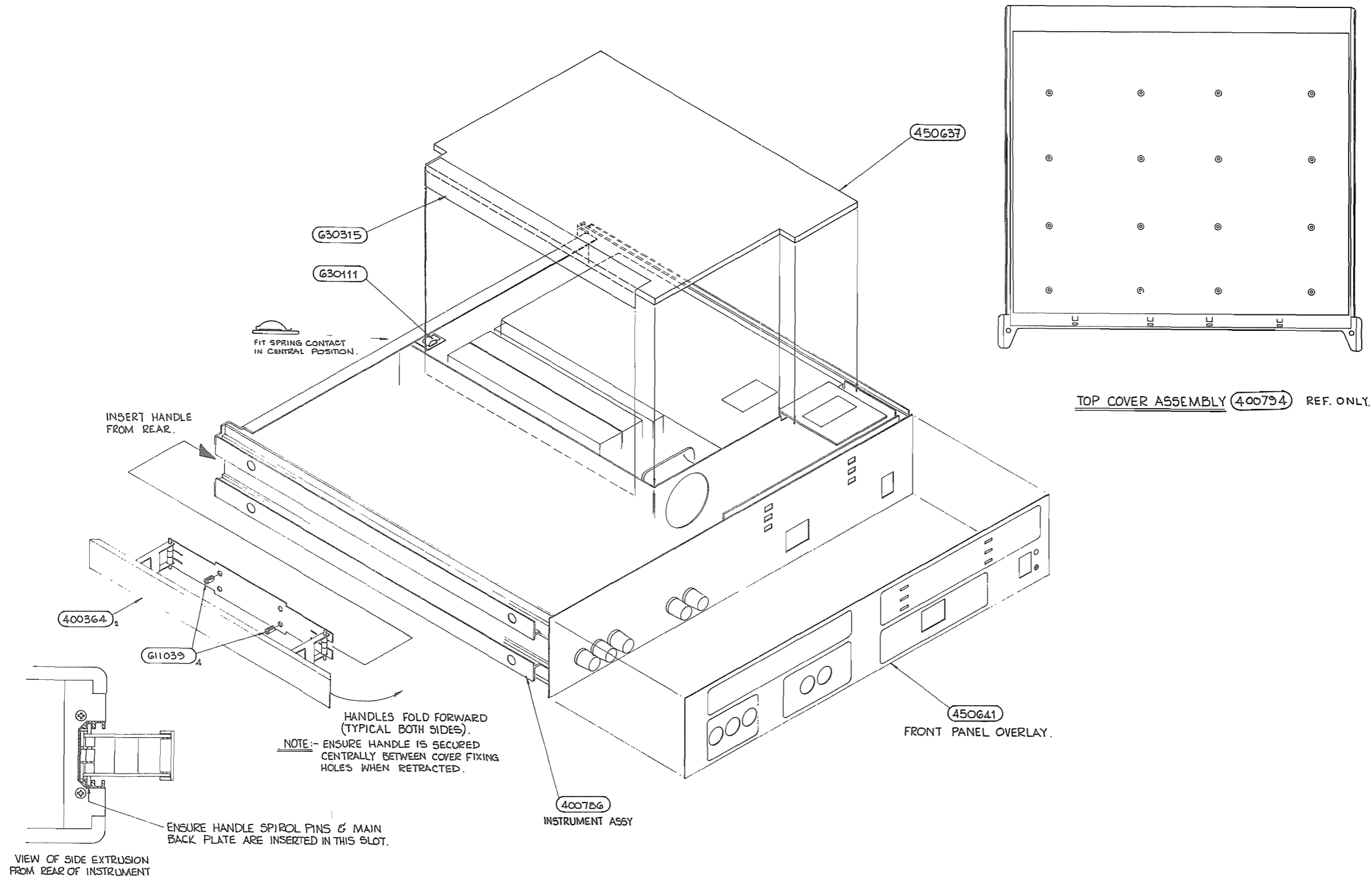

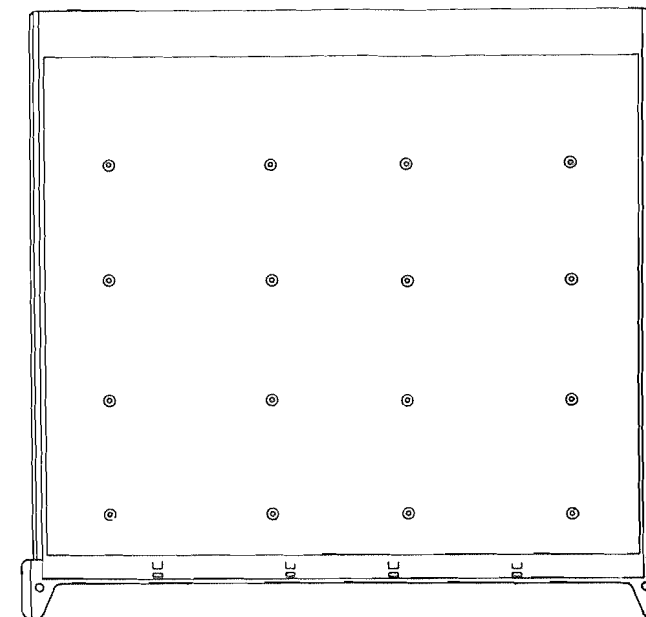
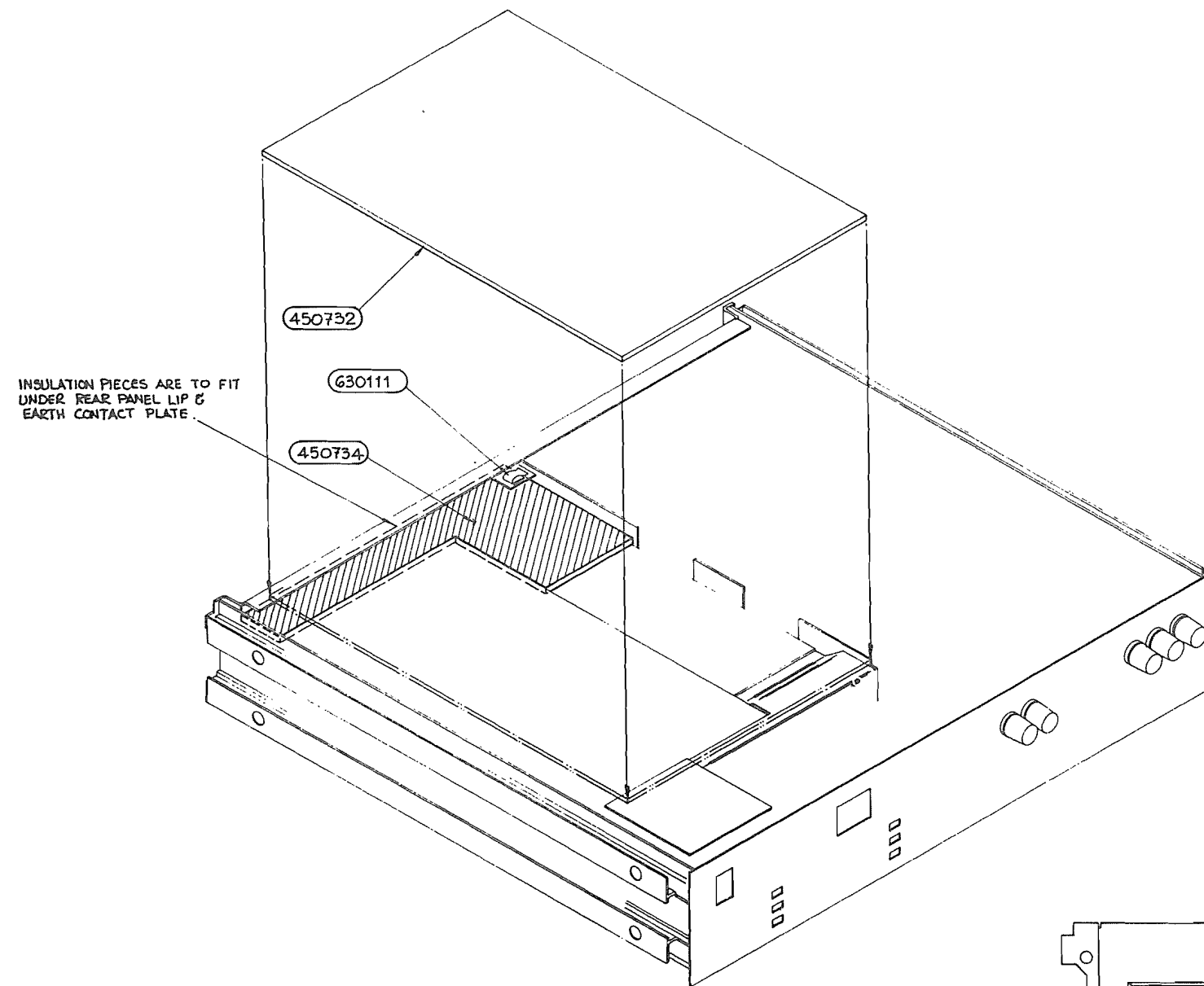

BOTTOM COVER ASSEMBLY (400795) REF. ONLY.

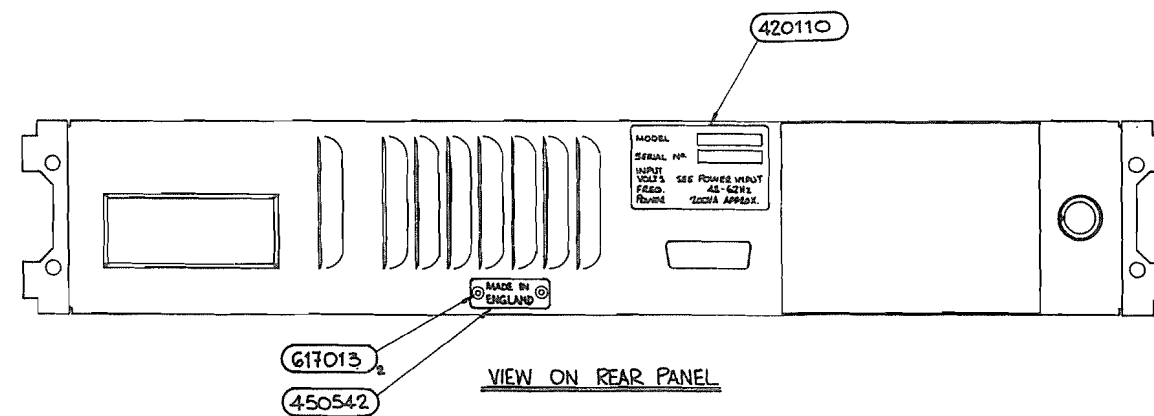

FINISHED ASSEMBLY

Drawing No. DA400785 Sheet 2

4600
datron
 INSTRUMENTS
 © Datron Instruments 1988

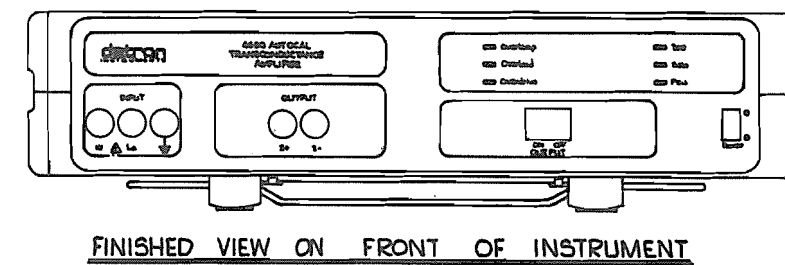
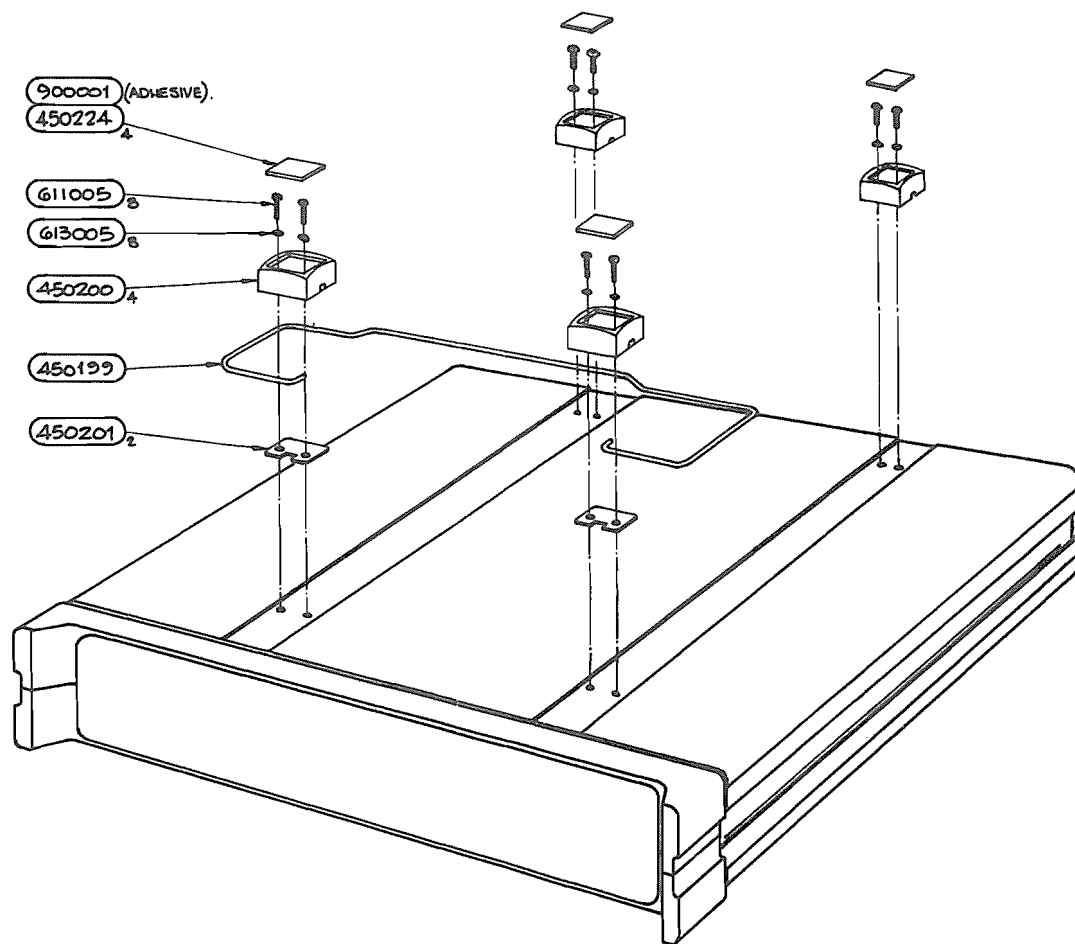
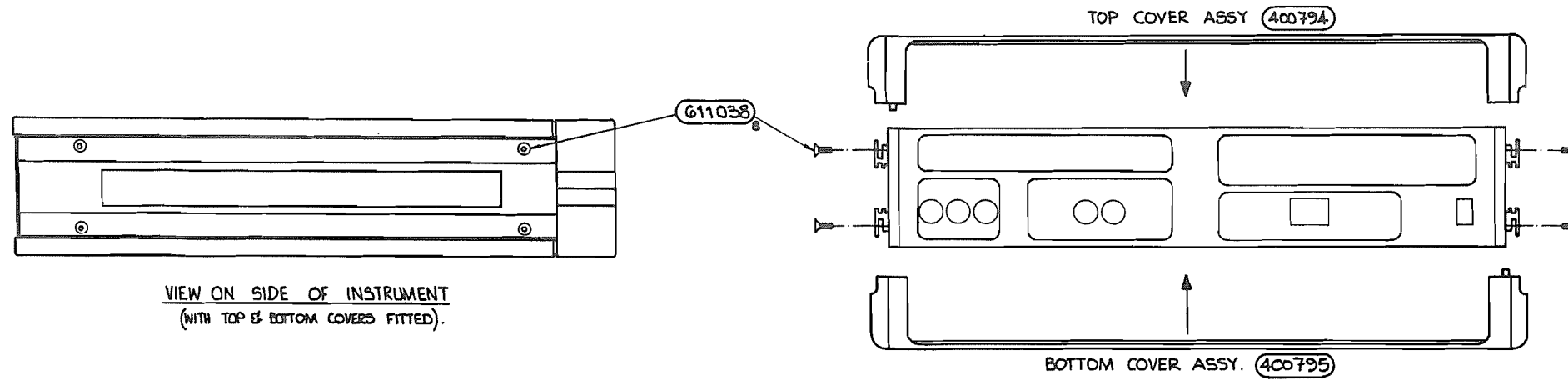

NOTE:- THE FOLLOWING ITEMS ARE TO BE INCLUDED IN THE ACCESSORY WALLET IN THE FRONT OF THE HANDBOOK

PART NO.	DESCRIPTION	QTY
630101	2mm A/F HEX KEY	1
630103	2.5mm A/F HEX KEY	1
920203	2.5A 32mm FUSE	1

DESIG	PART NO	DESCRIPTION	PRINC MANUF	MANUF PART NUMBER	CLASS	UM	QUANTITY	CHANGES
	400364-2	HANDLE ASSY	DATRON	SEE DRG			EA	2
	400786-1	ASSY INSTRUMENT 4600	DATRON	SEE DRG			EA	1
	400794-1	ASSY COVER TOP 4600	DATRON	SEE DRG			EA	1
	400795-1	ASSY COVER BOTTOM 4600	DATRON	SEE DRG			EA	1
	420098	LABEL SERIAL/ASSY No.	RS	554-793			EA	1
	420110-1	RATING LABEL		SEE DRG			EA	1
	440063-1	KIT RACK MTG 1061	DATRON	SEE DRG			AR	-
	440151-1	KIT INTERCONNECTION LEAD 4600	DATRON	SEE DRG			AR	-
	440154-1	KIT OUTPUT LEAD 4600	DATRON	SEE DRG			AR	-
	440156-1	KIT 115V 60Hz 4600	DATRON	SEE DRG			AR	-
	450199-1	TILT STAND		SEE DRG			EA	1
	450200-1	MOULDED FOOT		SEE DRG			EA	4
	450201-2	TILT STAND PLATE		SEE DRG			EA	2
	450224-2	FOOT PAD		SEE DRG			EA	4
	450234-1	PACKING BOX		SEE DRG			EA	1
	450641-1	OVERLAY 4600		SEE DRG			EA	1
	450542-1	MADE IN ENGLAND BADGE		SEE DRG			EA	1
	450637-2	INSULATOR 4600		SEE DRG			EA	1
	450732-1	INSULATION BOTTOM 4600		SEE DRG			EA	1
	450734-1	INSULATION BACK 4600		SEE DRG			EA	1
	611005	SCREW M3 X 12 POZIPAN SZP					EA	8
	611038	SCREW M4 X 12 SKT CSK SS BLK	IONIC				EA	8
	611039	SCREW M4 X 6 SKT GRUB HTSBZP					EA	4
	613005	WASHER M3 INT SHAKEPROOF					EA	8
	617013	RIVET POP 2.4 DOMED HD	GEORGE TUCKER	EYELET TAP/D/33/BH			EA	2
	630101	2.0mm HEX KEY	UNBRAKO	2.0mm A/F			EA	1
	630109	2.5mm HEX KEY	UNBRAKO	2.5mm A/F			EA	1
	630111	FINGER CONTACT (60 STRIP)	WALMORE	ELECT 97-500A			EA	2
	630315	TAPE PVC INSULATION 38MM WIDE	3M	TYPE 33			AR	1
	630224	BAG ANTI STATIC PINK	OK INDUSTRIES	400G (445X571X610)			EA	1
	850243-1	HANDBOOK USERS 4600		SEE DRG			EA	1
	900001	ADHESIVE CYANOCRYLATE	AVDEL	AVDELBOND 2			AR	1
	920012	MAINS LEAD/CONN	BELLING LEE	L/949			EA	1
	920209	FUSE 2.5A 32mm QUI-B	LITTLEFUSE	31202.5			EA	1

End

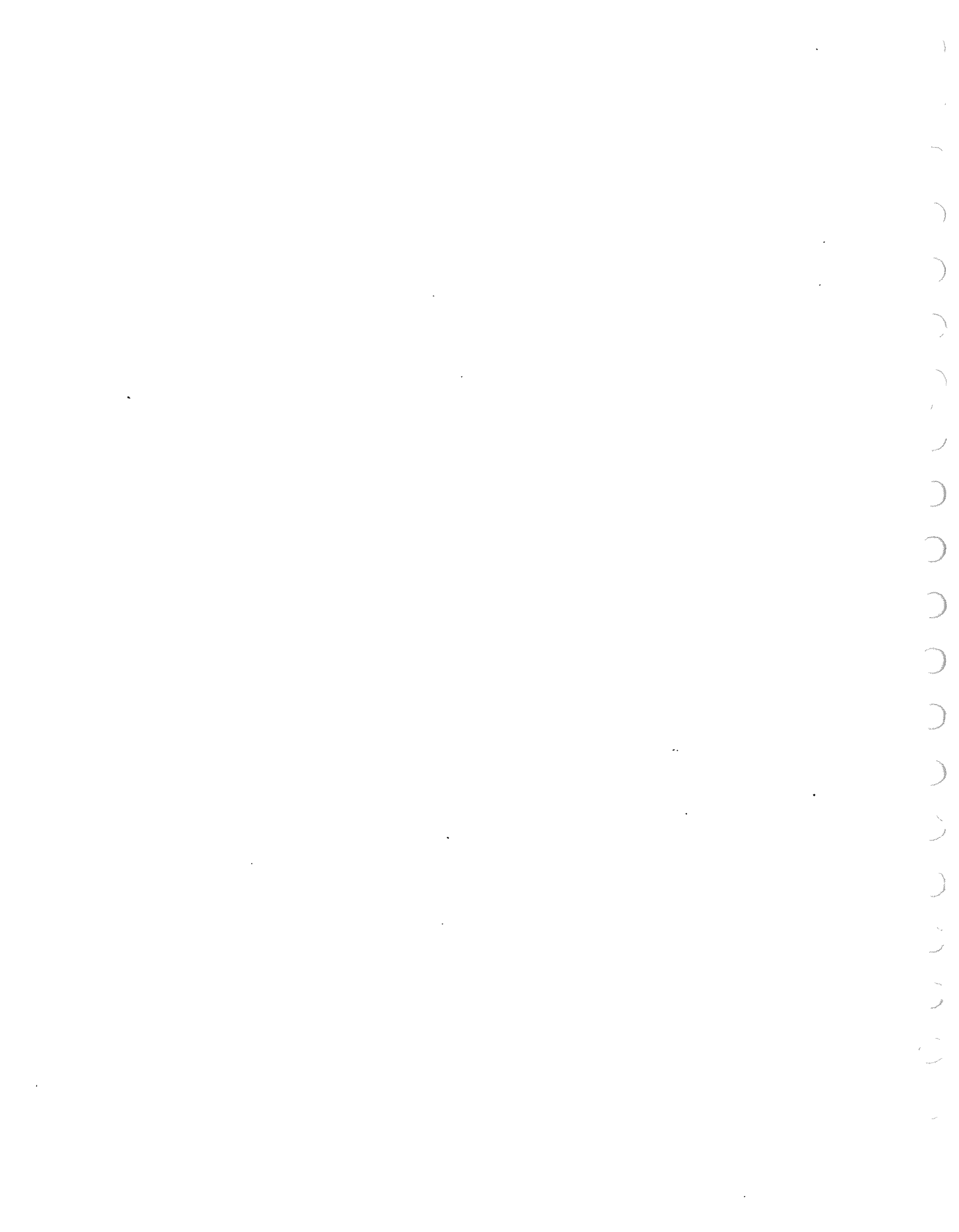

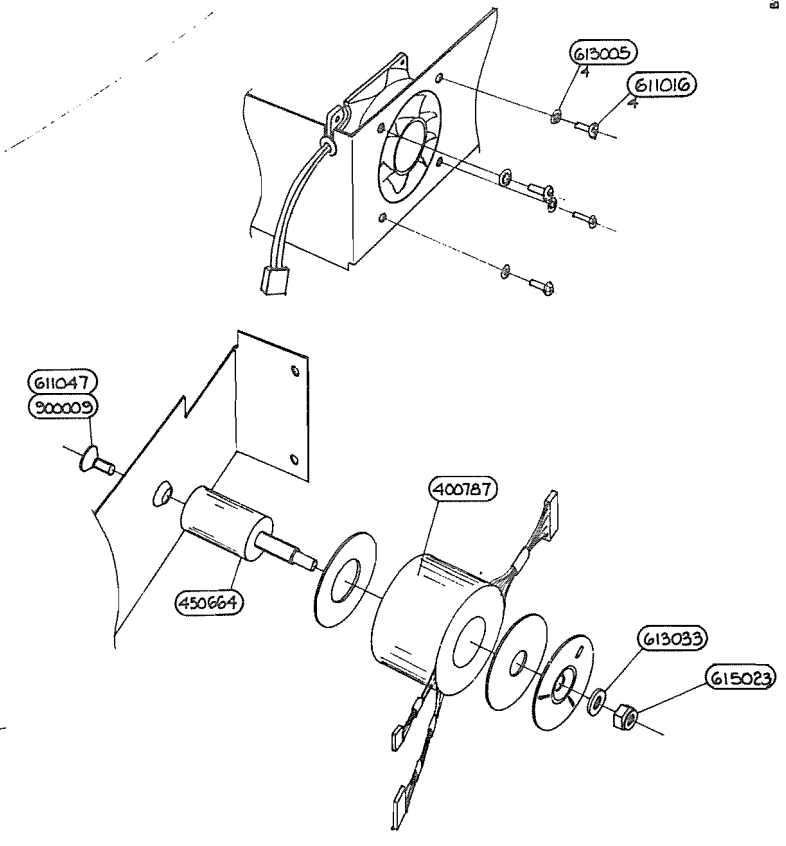
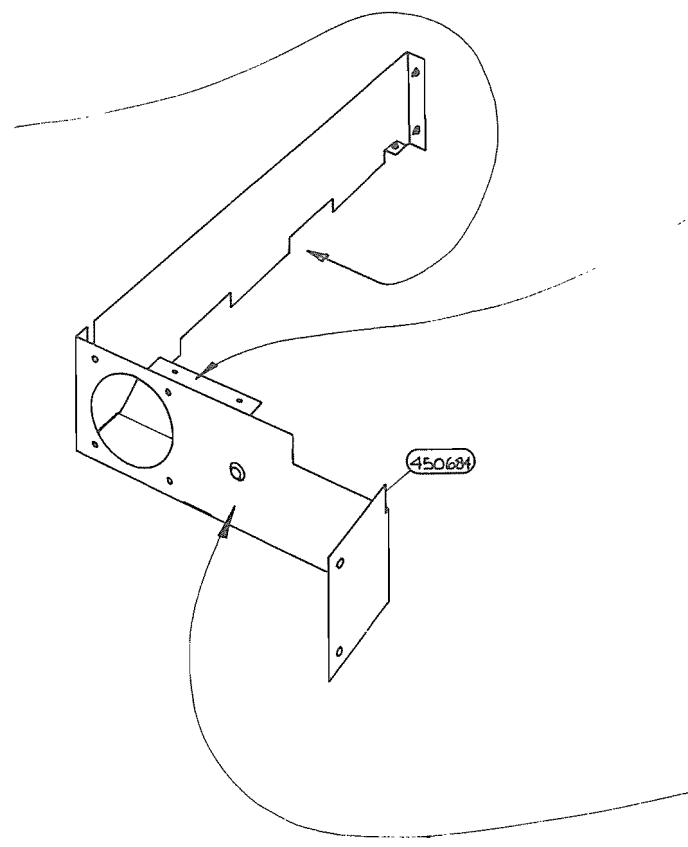
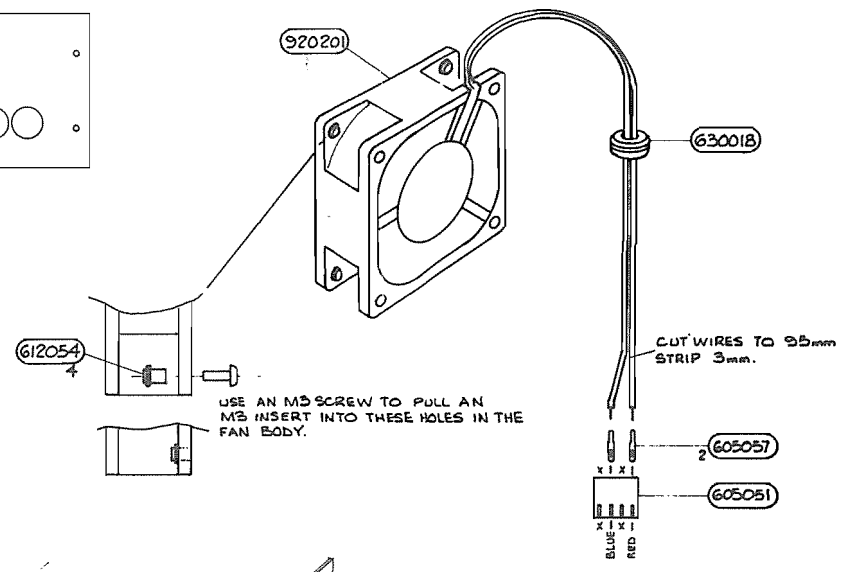
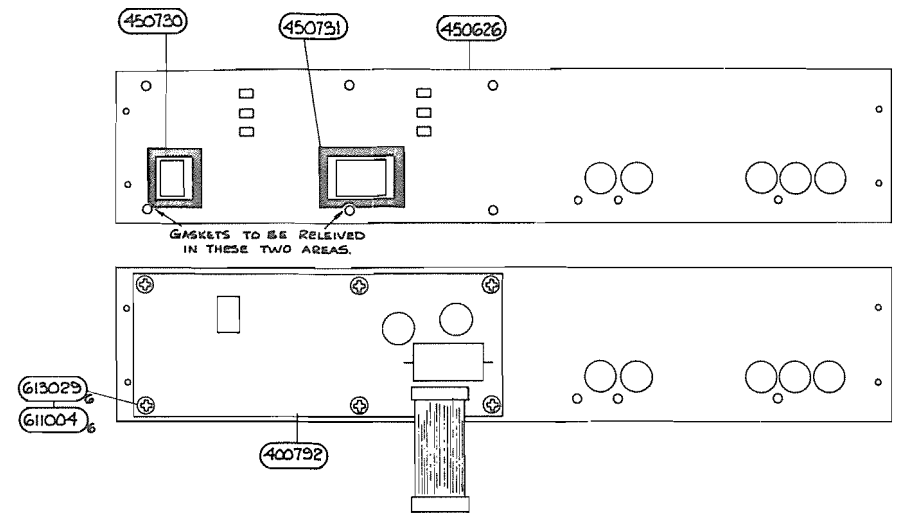
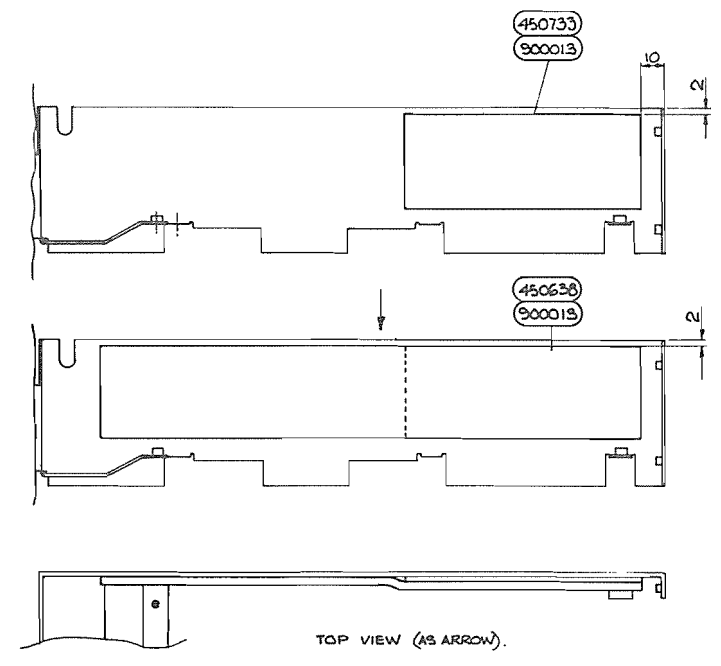
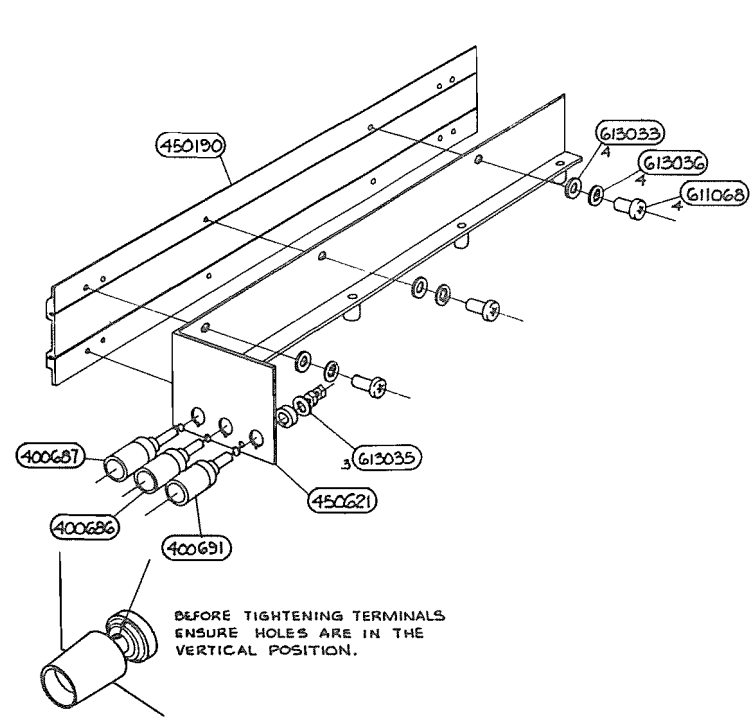

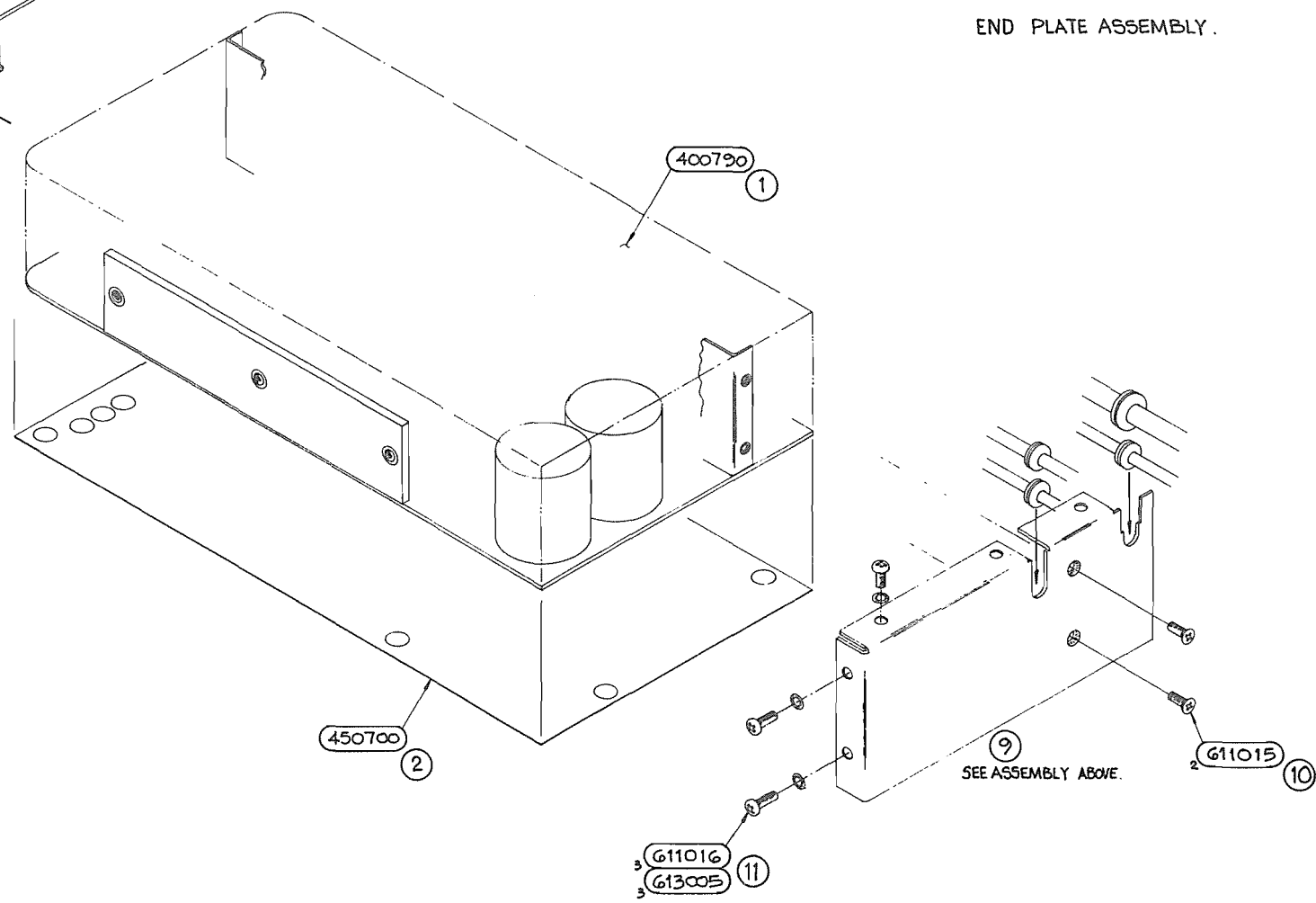
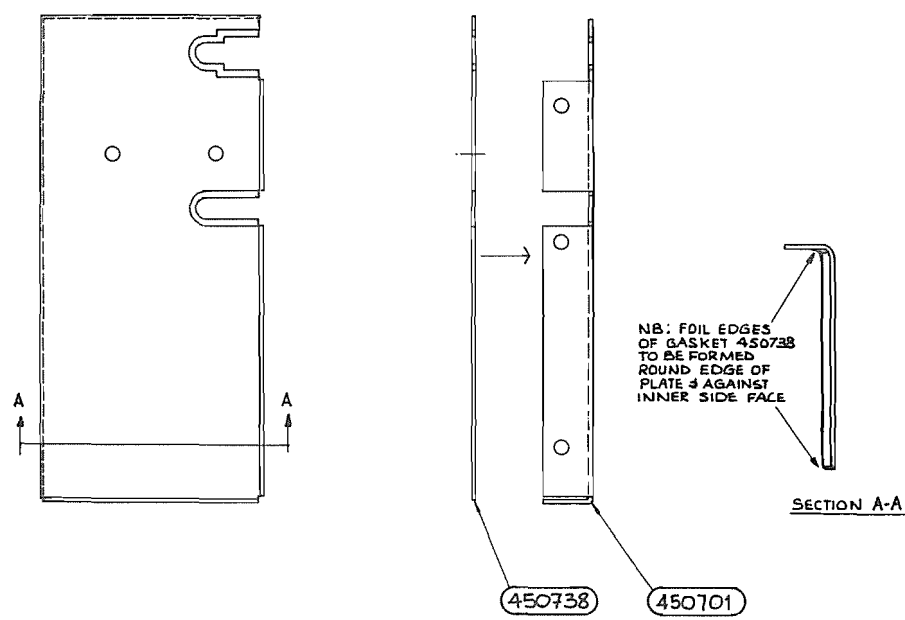
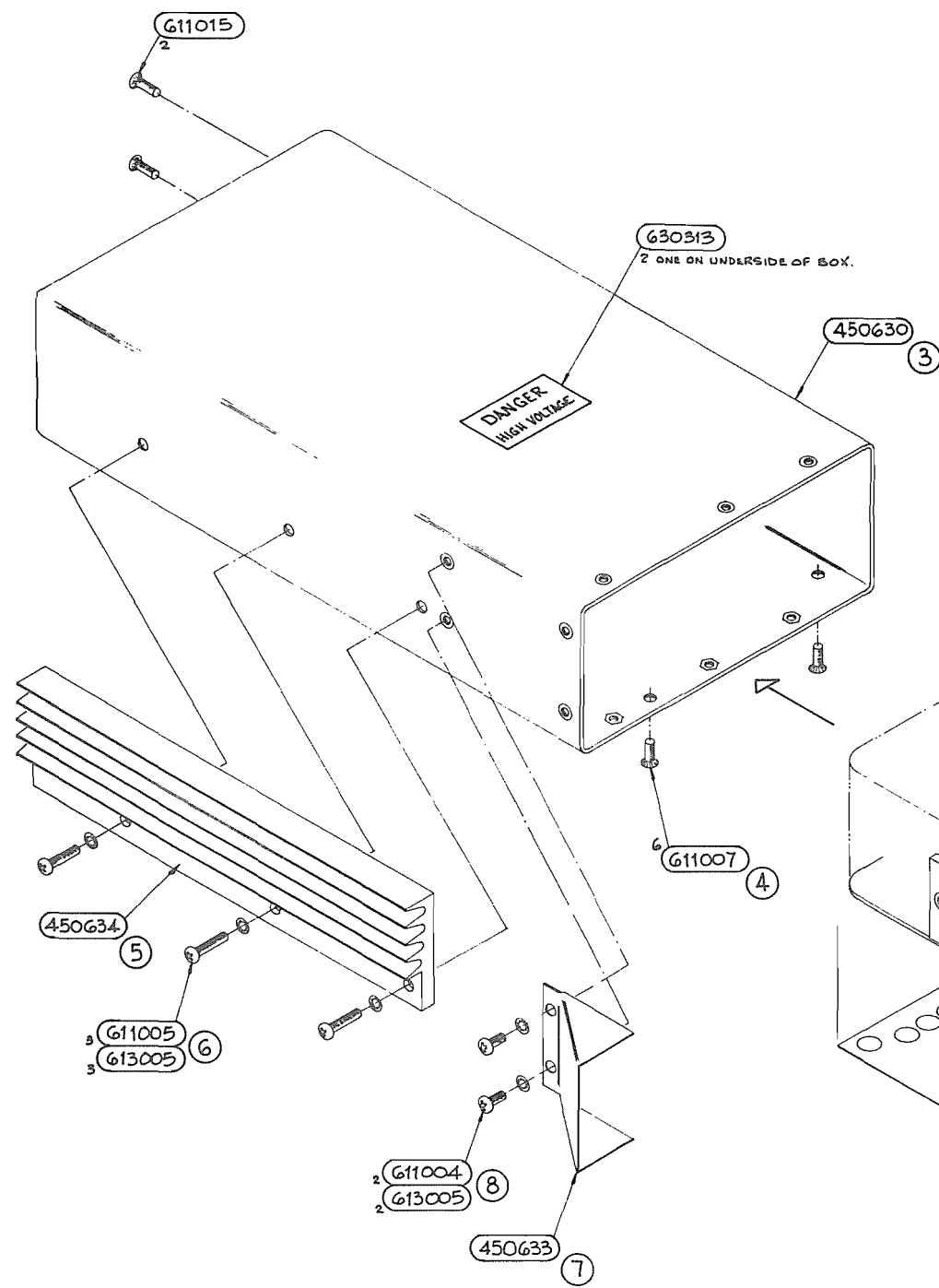

NOTE
 ASSEMBLE IN NUMBER SEQUENCE
 SHOWN THUS :- ①, ② ETC.

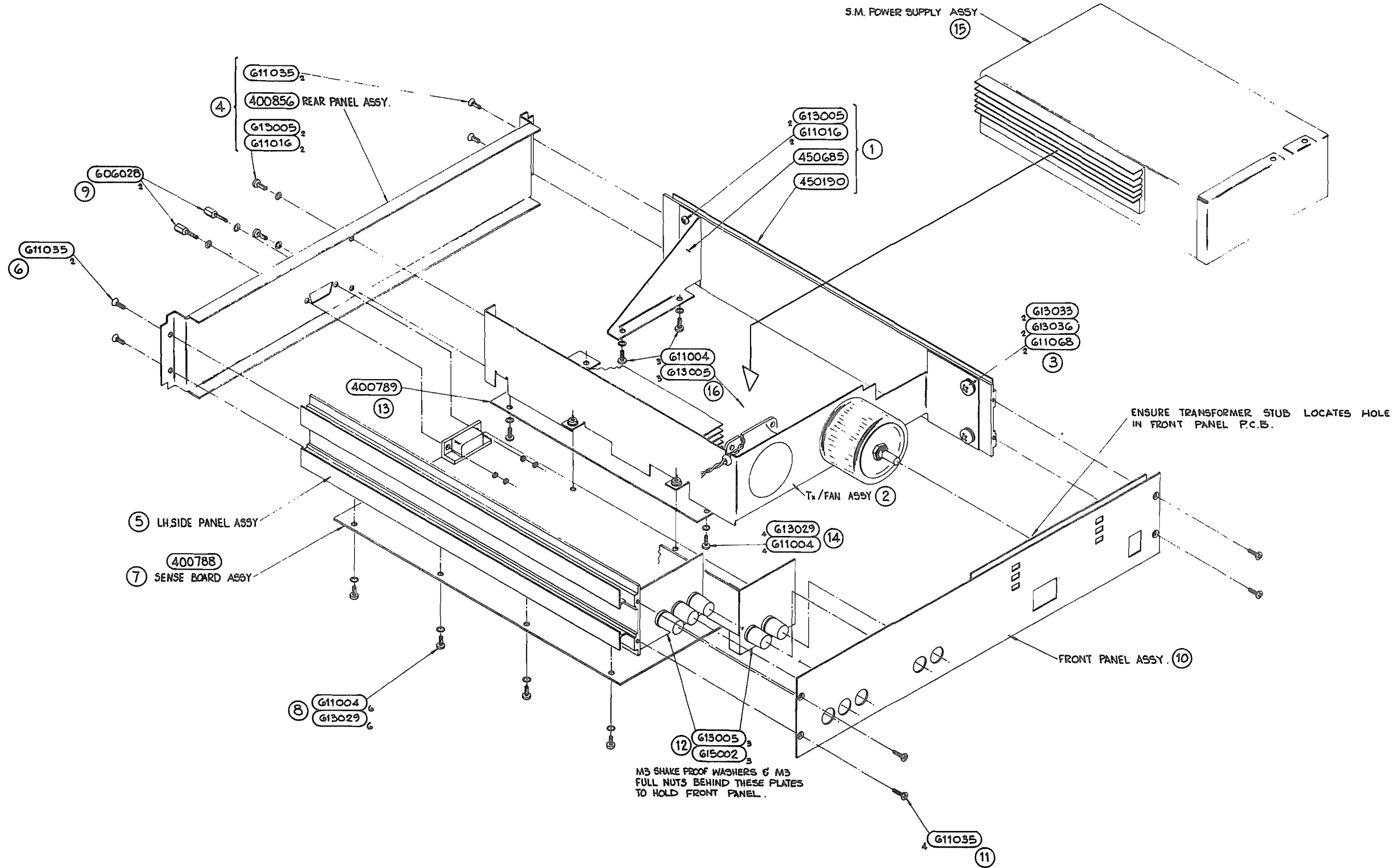

* - SOLDERED CONNECTION.

FOR CONNECTION OF CABLES TO THIS BOARD
SEE DRG DA400786 SHT 5.

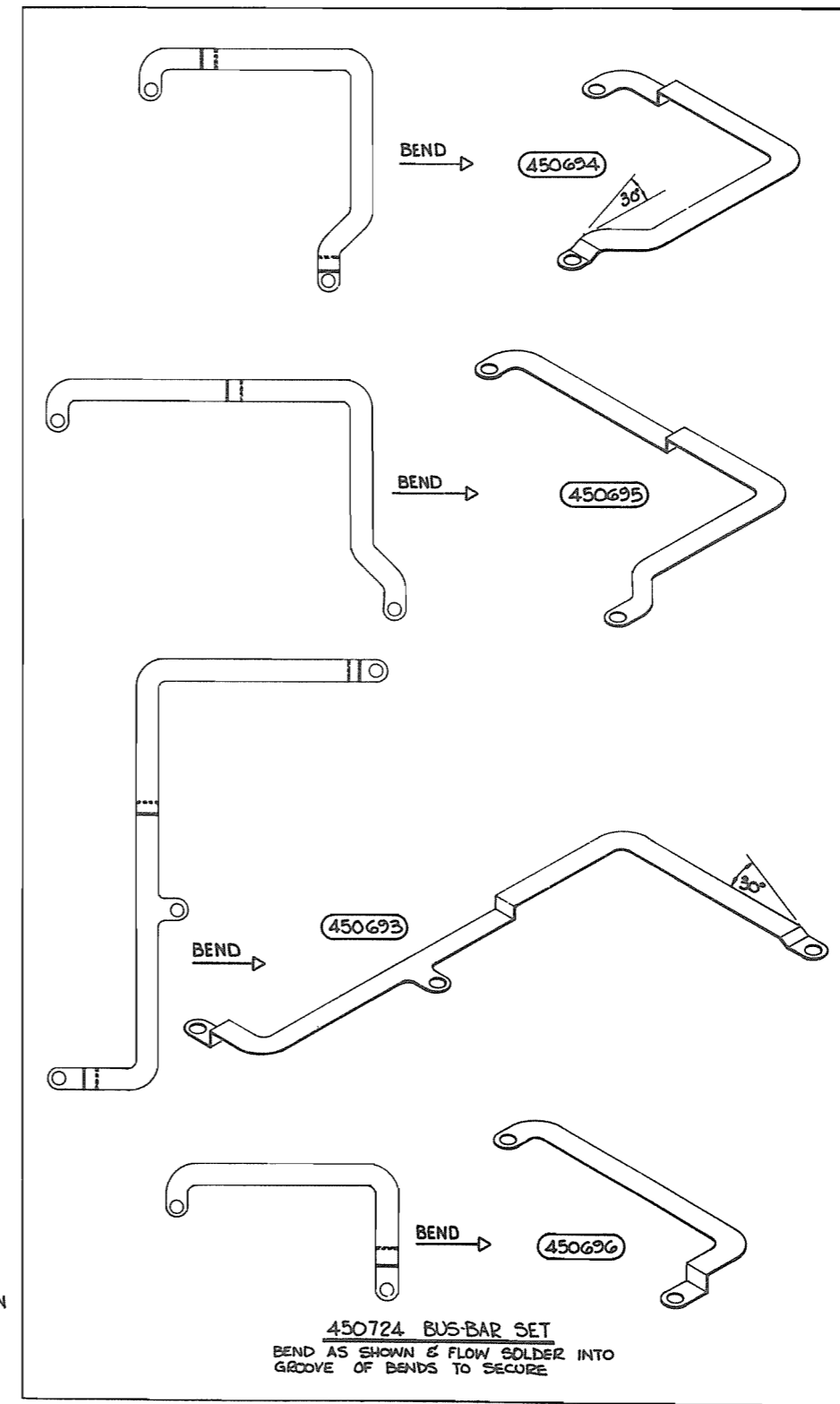
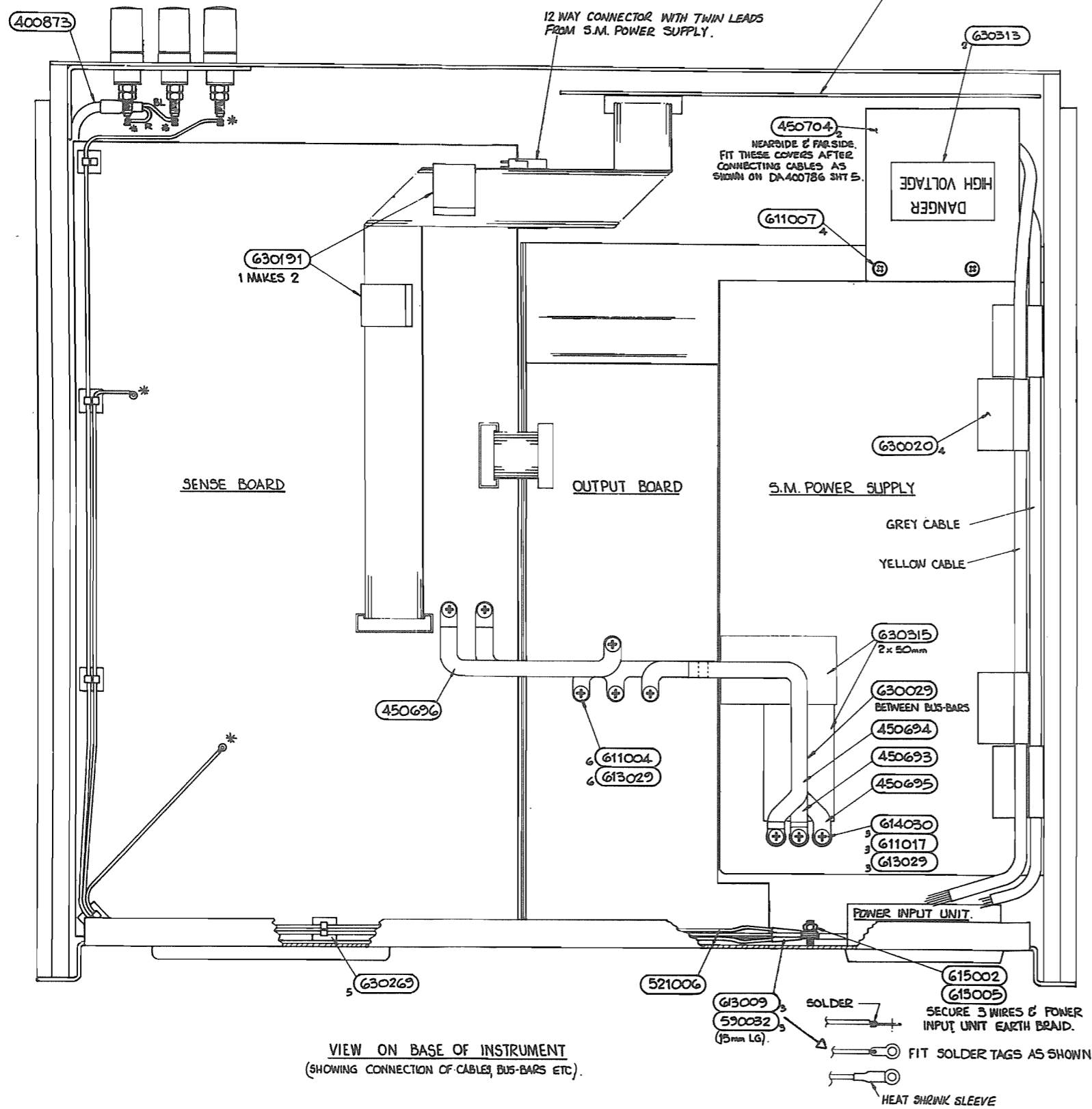

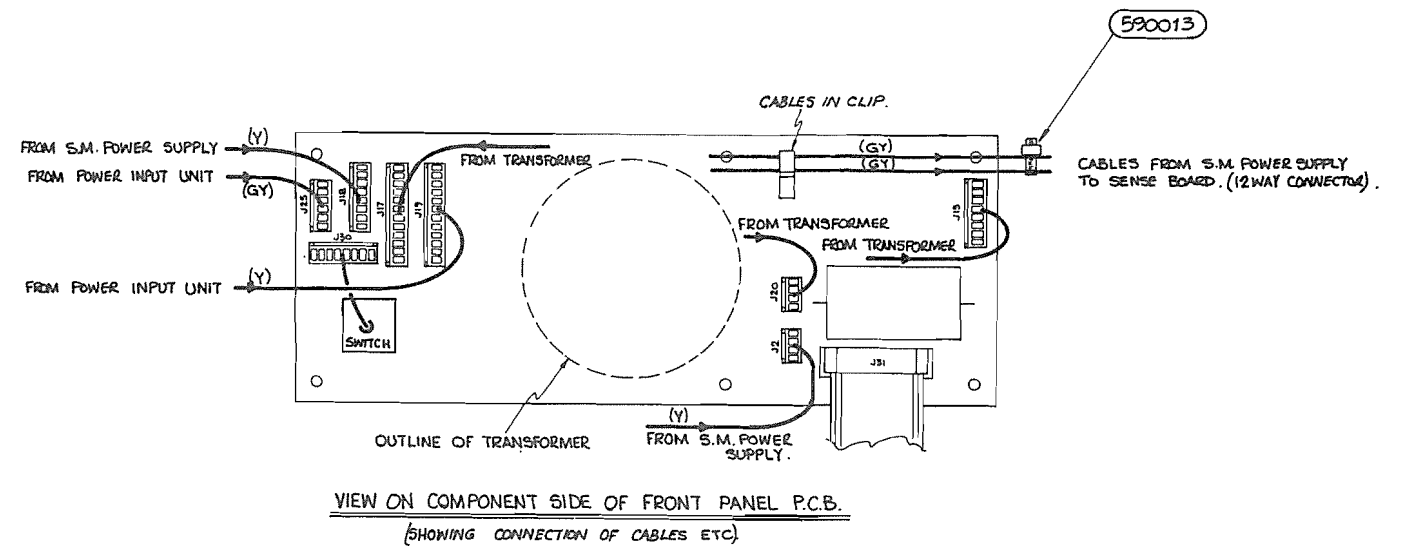
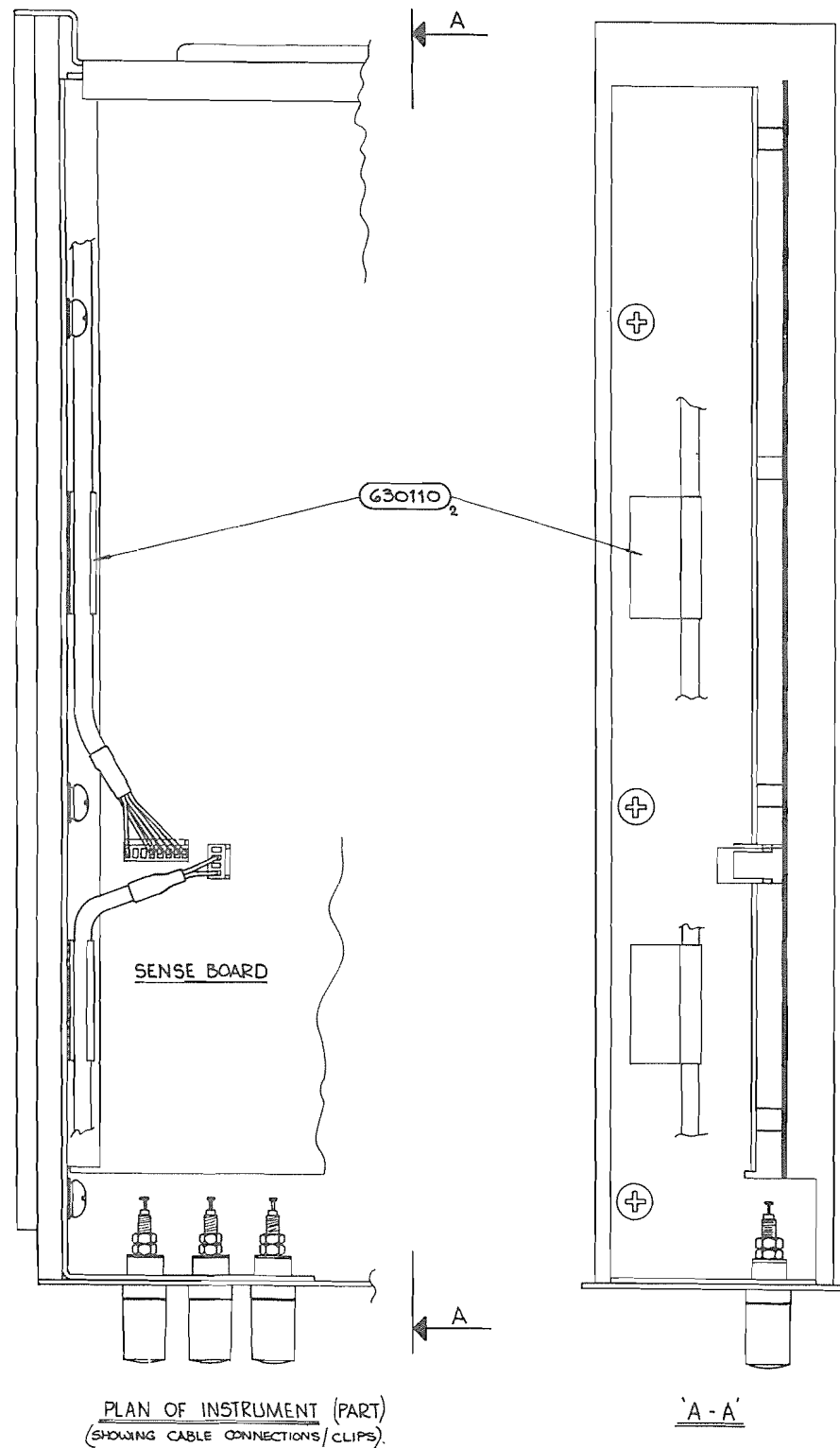



DESIG	PART NO	DESCRIPTION	PRINC MANUF	MANUF PART NUMBER	CLASS	UM	QUANTITY	CHANGES
	400686-1	ASSY SAFETY TERMINAL BLK		SEE DRG		EA	1	
	400687-1	ASSY SAFETY TERMINAL RED		SEE DRG		EA	1	
	400691-1	ASSY SAFETY TERMINAL GRN.		SEE DRG		EA	1	
	400787-1	ASSY MAINS TRANS 4600	DATRON	SEE DRG		EA	1	
	400788-1	ASSY PCB SENSE 4600	DATRON	SEE DRG		EA	1	
	400789-1	ASSY PCB OUTPUT 4600	DATRON	SEE DRG		EA	1	
	400790-1	ASSY PCB SMPS MAIN 4600	DATRON	SEE DRG		EA	1	
	400792-1	ASSY PCB FRONT 4600	DATRON	SEE DRG		EA	1	
	400856-1	ASSY PANEL REAR 4600	DATRON	SEE DRG		EA	1	
	400873-1	ASSY FRONT INPUT CABLE	DATRON	SEE DRG		EA	1	
	450190-3	SIDE EXTRUSION		SEE DRG		EA	2	
	450621-1	SUPPORT BRKT INPUT TERM 4600		SEE DRG		EA	1	
	450626-1	FRONT PANEL 4600		SEE DRG		EA	1	
	450630-1	EARTH BOX SMPS 4600		SEE DRG		EA	1	
	450633-1	AIR DEFLECTION SHIELD 4600		SEE DRG		EA	1	
	450634-1	SMPS HEATSINK		SEE DRG		EA	1	
	450638-1	INSULATION SIDE		SEE DRG		EA	1	
	450664-1	TRANSFORMER MTG POST 4600		SEE DRG		EA	1	
	450684-1	MAIN SUPPORT BRKT 4600		SEE DRG		EA	1	
	450685-1	REAR BOX SUPPORT 4600		SEE DRG		EA	1	
	450700-1	INSULATION SHEET SMPS 4600		SEE DRG		EA	1	
	450701-1	BOX END PLATE SMPS 4600		SEE DRG		EA	1	
	450704-1	MAINS SCREEN 4600		SEE DRG		EA	2	
	450724-1	BUS BAR SET 4600		SEE DRG		EA	1	
	450730-1	GASKET MAINS SWITCH 4600		SEE DRG		EA	1	
	450731-1	GASKET FRONT PANEL SWITCH 4600		SEE DRG		EA	1	
	450733-1	INSULATION SIDE		SEE DRG		EA	1	
	450738-1	GASKET SMPS SCREEN 4600		SEE DRG		EA	1	
	521006	WIRE 16/.2 PVC 1KV GRN/YEL		359-380		AR	1	
	590013	STD CABLE TIE 32mm	RS	543-412		EA	1	
	590032	SLEEVE HS. 4.8mm YLW	R.S.COMPONENTS	399-518		AR	1	
	605051	HOUSING 4WAY	MOLEX	6471 SERIES 22-01-20		EA	1	
	605057	CRIMP TERMINAL GD PL	MOLEX	4809-GI		EA	2	
	606028	'D' SCREW LOCK	CANNON	D20418-2		EA	2	
	611004	SCREW M3 X 6 POZIPAN SZP				EA	27	
	611005	SCREW M3 X 12 POZIPAN SZP				EA	3	
	611007	SCREW M3 X 6 POZICSK SZP				EA	10	
	611015	SCREW M3 X 8 POZICSK SZP				EA	4	
	611016	SCREW M3 X 8 POZIPAN SZP				EA	11	
	611017	SCREW M3 X 16 POZIPAN SZP				EA	3	
	611035	SCREW M3 X 8 POZICSK TT SZP BC				EA	8	
	611047	SCREW M5 X 12 POZICSK SZP				EA	1	
	611068	SCREW M6 X 10 POZIPAN SZP				EA	6	
	612054	INSERT LIGHTWEIGHT M3	PRECISION SCREW CO	ROSAN M3 LIGHTWEIGHT		EA	4	
	613005	WASHER M3 INT SHAKEPROOF				EA	23	

DESIG	PART NO	DESCRIPTION	PRINC MANUF	MANUF PART NUMBER	CLASS	UM	QUANTITY	CHANGES
	613009	SOLDER TAG 4 BA BTP				EA	3	
	613029	WASHER M3 WAVY SS				EA	25	
	613033	WASHER M6 SZP	SCHROFF	21100-104		EA	7	
	613035-1	WASHER LARGE M4	-	SEE DRAWING		EA	3	
	613036	WASHER M6 INT. SHAKP.				EA	6	
	614030	SPACER M3 CLEAR X 8	HARWIN	R6363-02		EA	3	
	615002	NUT M3 FULL SZP				EA	4	
	615023	NUT NYLOCK M6				EA	1	
	630018	GROMMET 4.0 DIA.	R S COMPONENTS	543-197		EA	1	
	630020	CLIP CABLE 4 DIA.	3M	708		EA	4	
	630029	TAPE 1/4" X 1/32" DBL.SIDED	3M	4032		AR	1	
	630110	CLIP CABLE 6 DIA	3M	710		EA	2	
	630191	CLIP RIBBON CABLE	RICHCO	DFCC-2		EA	1	
	630269	CLIP CABLE SELF-ADHESIVE	RICHCO	MWSB		EA	5	
	630313	LABEL DANGER HIGH VOLTAGE				EA	4	
	630315	TAPE PVC INSULATION 38MM WIDE	3M	TYPE 33		AR	1	
	900009	LOCKING COMPOUND	LOCTITE	222		AR	1	
	900013	ADHESIVE CYANOACRYLATE	LOCTITE	496		AR	1	
	920201	FAN 24V AXIAL	PAPST	814		EA	1	

End

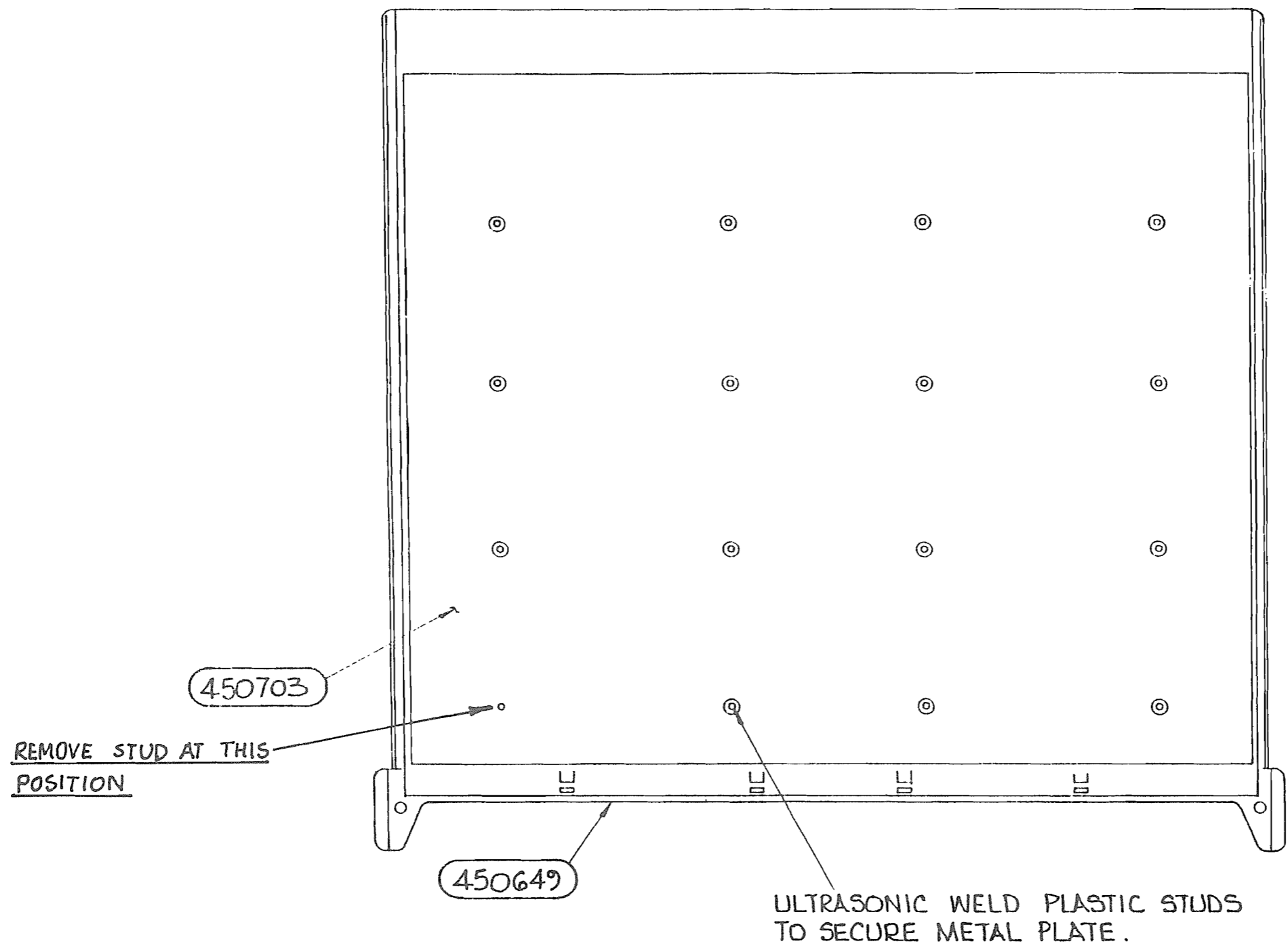

TOP COVER ASSEMBLY

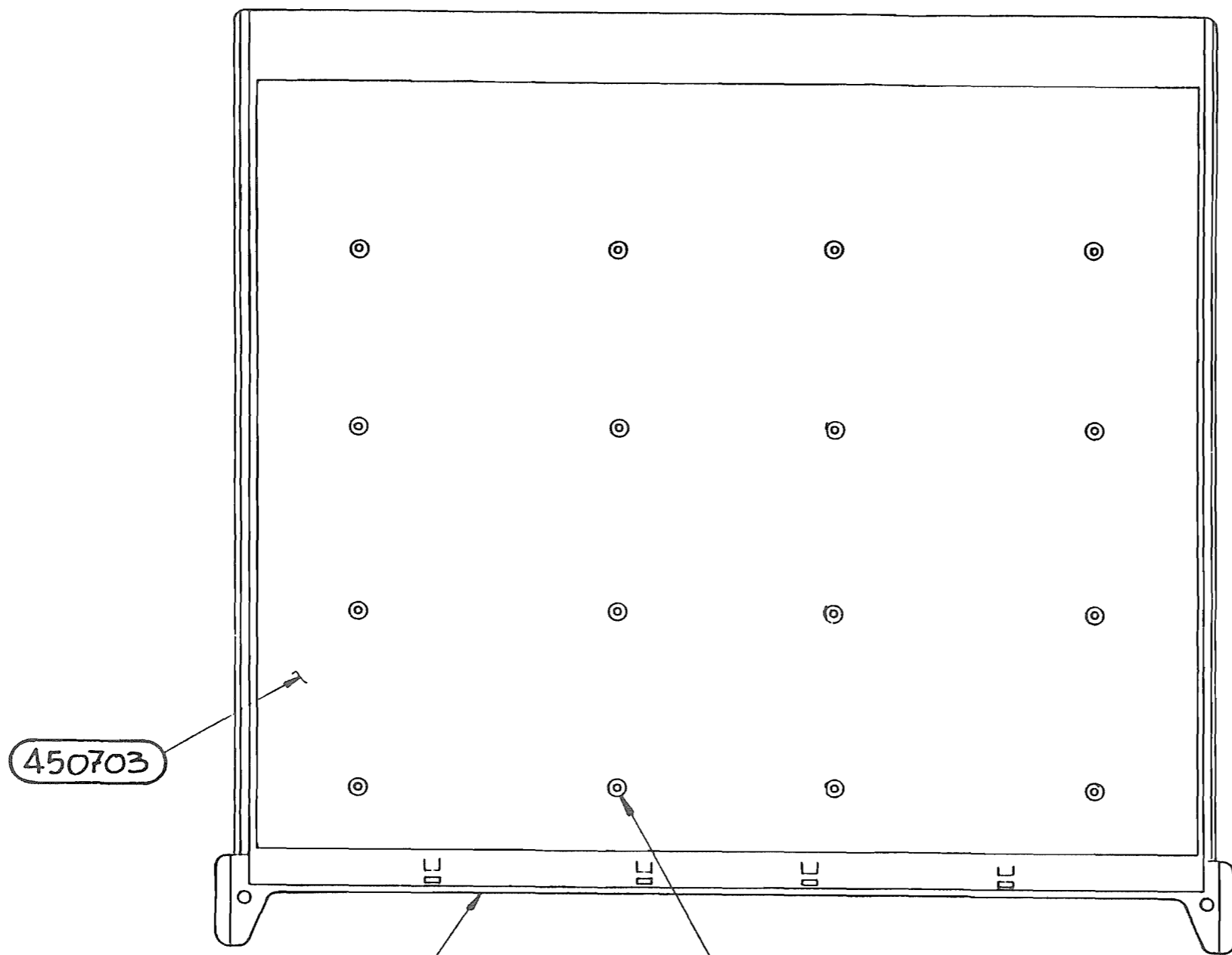

450703

450642

ULTRASONIC WELD PLASTIC STUDS
TO SECURE METAL PLATE.

BOTTOM COVER ASSEMBLY

DESIG	PART NO	DESCRIPTION	PRINC MANUF	MANUF PART NUMBER	CLASS	UM	QUANTITY	CHANGES
	450649-1	TOP COVER 4600		SEE DRG			EA 1	
	450703-1	EARTH SHEET 4600		SEE DRG			EA 1	

End

DESIG	PART NO	DESCRIPTION	PRINC MANUF	MANUF PART NUMBER	CLASS	UM	QUANTITY	CHANGES
	450642-1	BOTTOM COVER 4600		SEE DRG			EA 1	
	450703-1	EARTH SHEET 4600		SEE DRG			EA 1	

End

NOTES

1. AFTER ASSY, CHECK THAT THE SUSPENSION LINKS FIT INTO THE EXTRUSION SLOTS, WITHOUT INTERFERENCE, WHEN THE HANDLE IS FOLDED FLAT.

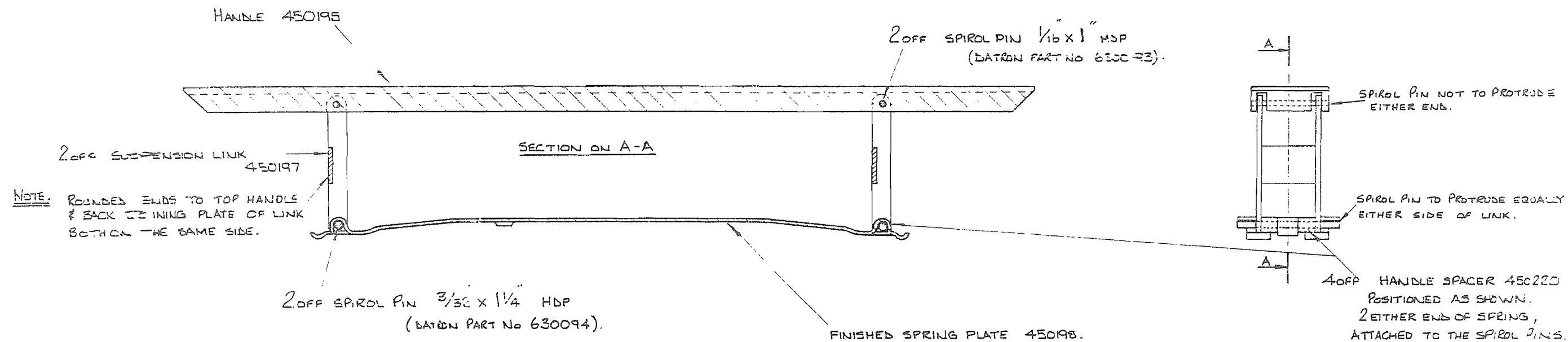

HANDLE ASSEMBLY

Drawing No. 480364

Sheet 1

4600
datron
INSTRUMENTS

© Datron Instruments 1988

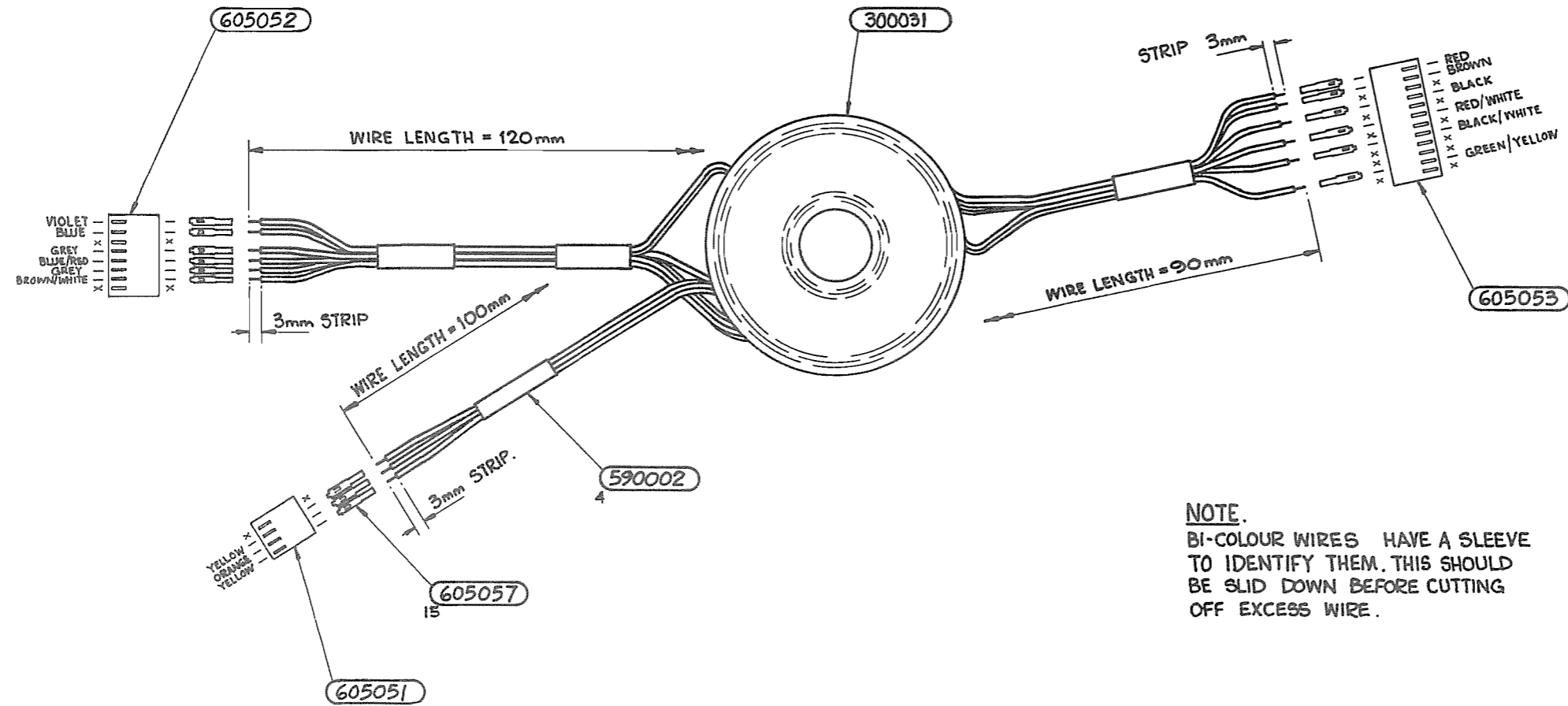

NOTE.
 BI-COLOUR WIRES HAVE A SLEEVE
 TO IDENTIFY THEM. THIS SHOULD
 BE SLID DOWN BEFORE CUTTING
 OFF EXCESS WIRE.

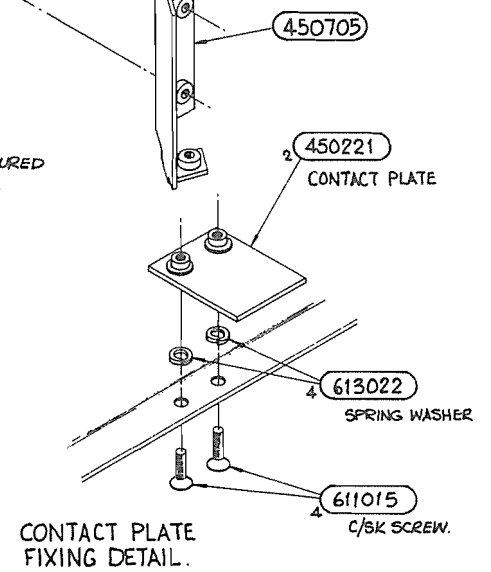
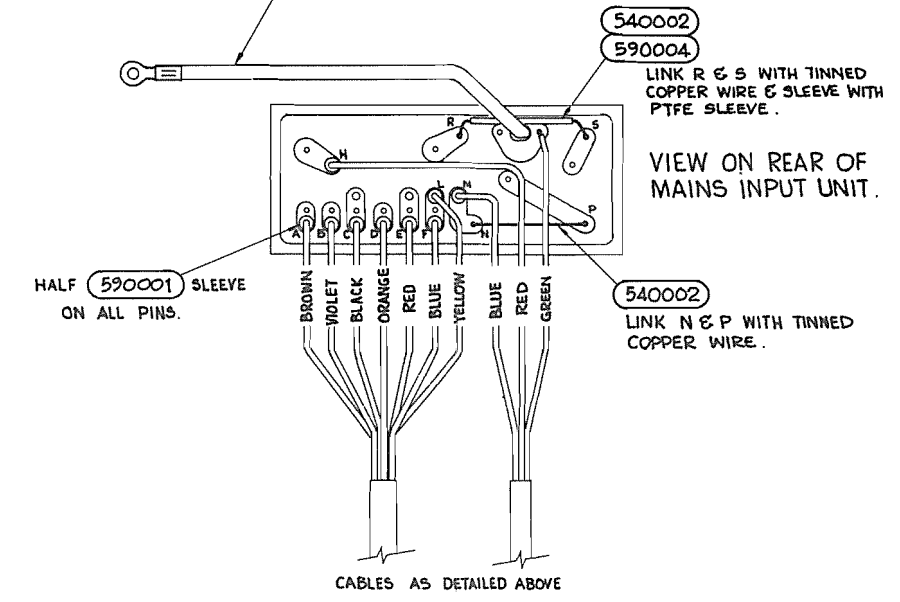
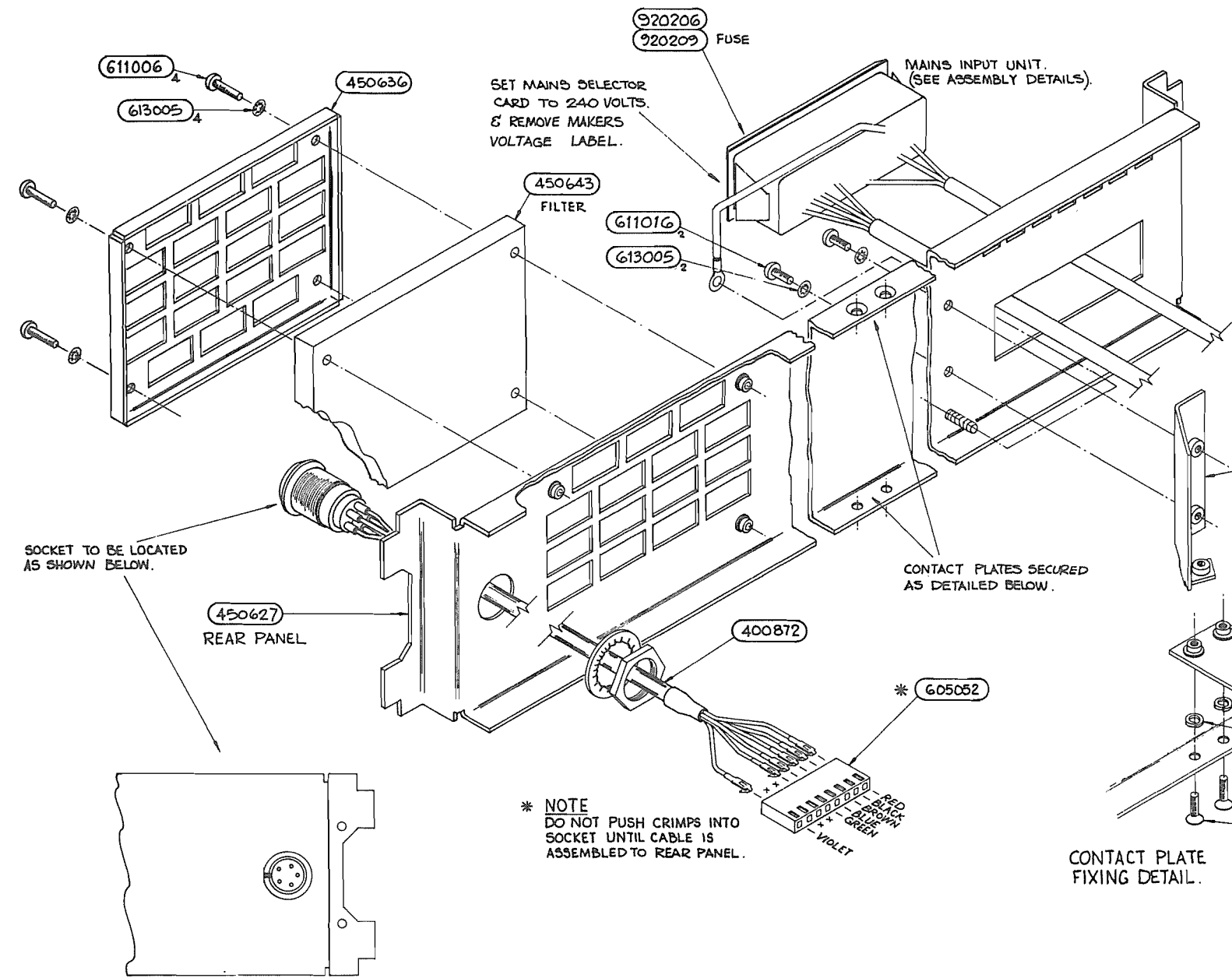
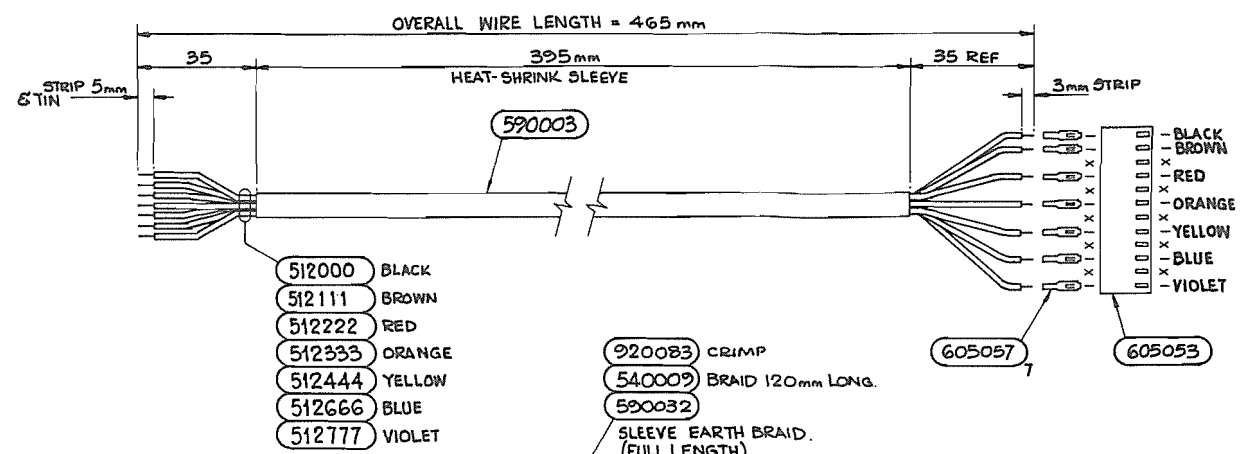
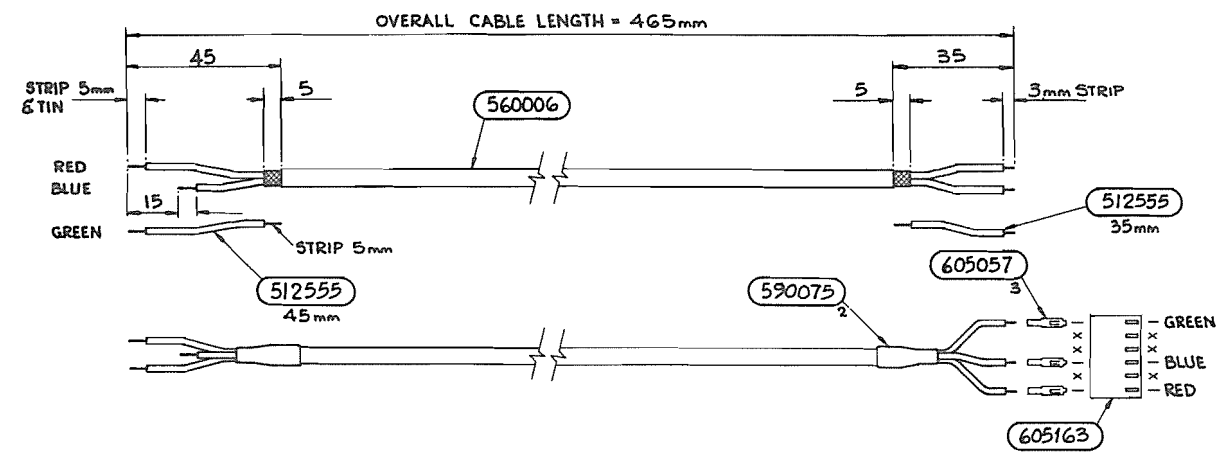

DESIG	PART NO	DESCRIPTION	PRINC MANUF	MANUF PART NUMBER	CLASS	UM	QUANTITY	CHANGES
	400872-1	ASSY REAR INPUT CABLE	DATRON	SEE DRG		EA	1	
	450643-1	AIR FILTER 4600		SEE DRG		EA	1	
	450221-1	CONTACT PLATE 4600		SEE DRG		EA	2	
	450627-2	PANEL REAR 4600		SEE DRG		EA	1	
	450636-1	AIR FILTER SUPPORT 4600		SEE DRG		EA	1	
	450705-1	OUTPUT STAGE SUPPORT BRKT 4600		SEE DRG		EA	1	
	512000	WIRE 7/.2 PTFE 1KV BLK	BSG210	TYPE C		AR	1	
	512111	WIRE 7/.2 PTFE 1KV BRN	BSG210	TYPE C		AR	1	
	512222	WIRE 7/.2 PTFE 1KV RED	BSG210	TYPE C		AR	1	
	512333	WIRE 7/.2 PTFE 1KV ORANGE	BSG210	TYPE C		AR	1	
	512444	WIRE 7/.2 PTFE 1KV YEL	BSG210	TYPE C		AR	1	
	512555	WIRE 7/.2 PTFE 1KV GRN	BSG210	TYPE C		AR	1	
	512666	WIRE 7/.2 PTFE 1KV BLU	BSG210	TYPE C		AR	1	
	512777	WIRE 7/.2 PTFE 1KV VIO	BSG210	TYPE C		AR	1	
	540002	WIRE 1/.7 TINNED COPPER	BS4109	22SWG		AR	1	
	540009	WIRE BRAID 1/8" TINNED CU	HEAD BRAIDING LTD	12-5-0048		AR	1	
	560006	CABLE 2 CORE PTFE SC				MM	465	
	590001	SLEEVE NP 1.5 X 20MM BLK	HELLERMAN	H15		EA	5	
	590003	SLEEVE HS. 6.4mm YLW.	R.S.COMONENTS	399-524		AR	1	
	590004	SLEEVE PTFE 1mm BLK	HELLERMAN	FE10		AR	1	
	590032	SLEEVE HS. 4.8mm YLW	R.S.COMONENTS	399-518		AR	1	
	590075	SOLDER SLEEVE DIAM 4.8	RAYFAST	CWT-5		EA	2	
	605052	HOUSING 8 WAY .1"	MOLEX	6471 SERIES 22-01-20		EA	1	
	605053	SOCKET HOUSING 12 WAY .1" PITCH	MOLEX	22-01-2125		EA	1	
	605057	CRIMP TERMINAL GD PL	MOLEX	4809-GL		EA	10	
	605163	SOCKET HOUSING 6 WAY .1" PITCH	MOLEX	22-01-2065		EA	1	
	611006	SCREW M3 X 10 POZIPAN SZP				EA	4	
	611015	SCREW M3 X 8 POZICSK SZP				EA	4	
	611015	SCREW M3 X 8 POZIPAN SZP				EA	2	
	613005	WASHER M3 INT SHAKEPROOF				EA	6	
	613022	WASHER M3 SQ. SPRING BZP				EA	4	
	920083	TERMINAL M3 RING	TAKBRO	W31.25-3		EA	1	
	920206	MAINS INPUT MODULE	POTTER	7100-0001		EA	1	
	920209	FUSE 2.5A 32mm QUI-B	LITTLEFUSE	31202.5		EA	1	

End

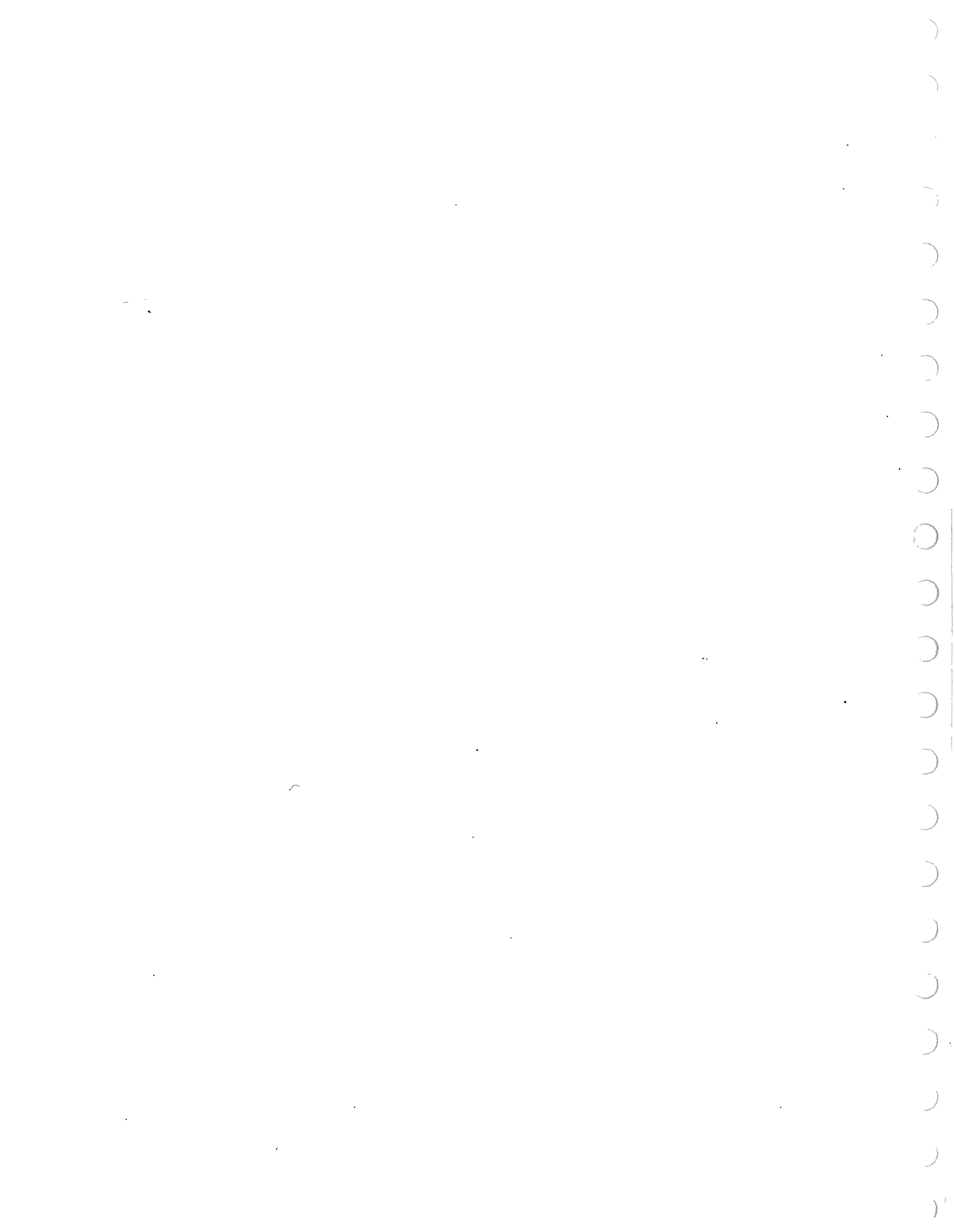

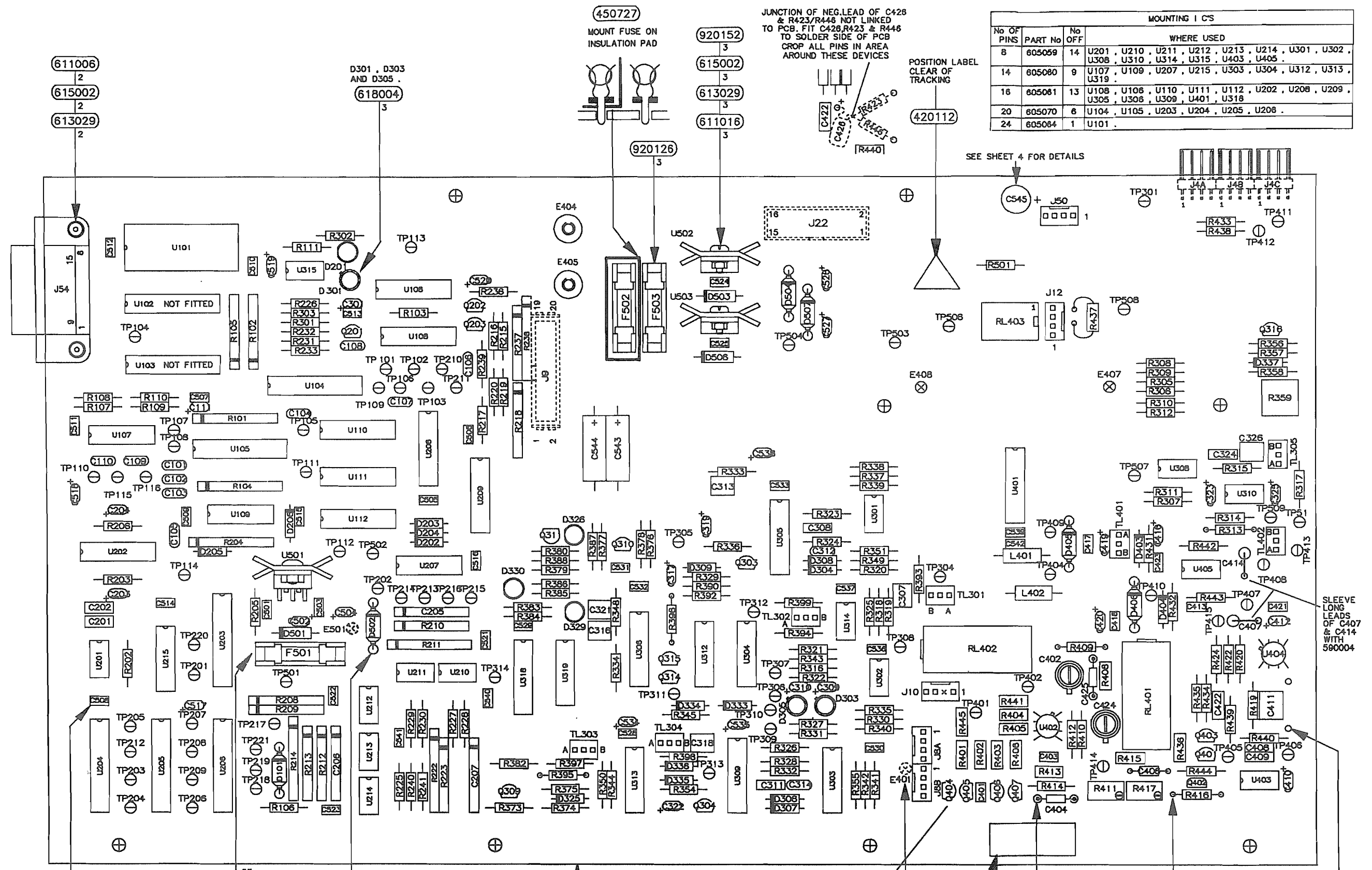

MOUNTING I CS			
No OF PINS	PART No	No OFF	WHERE USED
8	605059	14	U201, U210, U211, U212, U213, U214, U301, U302, U308, U310, U314, U315, U403, U405.
14	605080	9	U107, U109, U207, U215, U303, U304, U312, U313, U319.
16	605081	13	U108, U106, U110, U111, U112, U202, U208, U209, U305, U306, U309, U401, U318.
20	605070	6	U104, U105, U203, U204, U205, U206.
24	605084	1	U101.

C205, 206, 207, C401, 403, 414, 417, 418, 421, 423, 501, 502, C503, 505, 506, 507, 508, 509, 510, 511, 512, 513, C514, 515, 518, 521, 522, 523, 524, 525, 528, 529, C530, 531, 532, 533, 538, 537, 539, 540, 541, 542.
ONE BEAD PER LEAD

D101, D502, D504, D405, D406 AND D507.
ONE BEAD PER LEAD

SEE VIEW ABOVE FOR C426, R423 & R446
R313, R395, R396, R409, R416 AND C406.
POSITION LABEL IN AREA CLEAR OF TRACKING

SENSE PCB ASSEMBLY
Drawing No. DA400788 Sheet 1

4600
datron
INSTRUMENTS
© Datron Instruments 1988

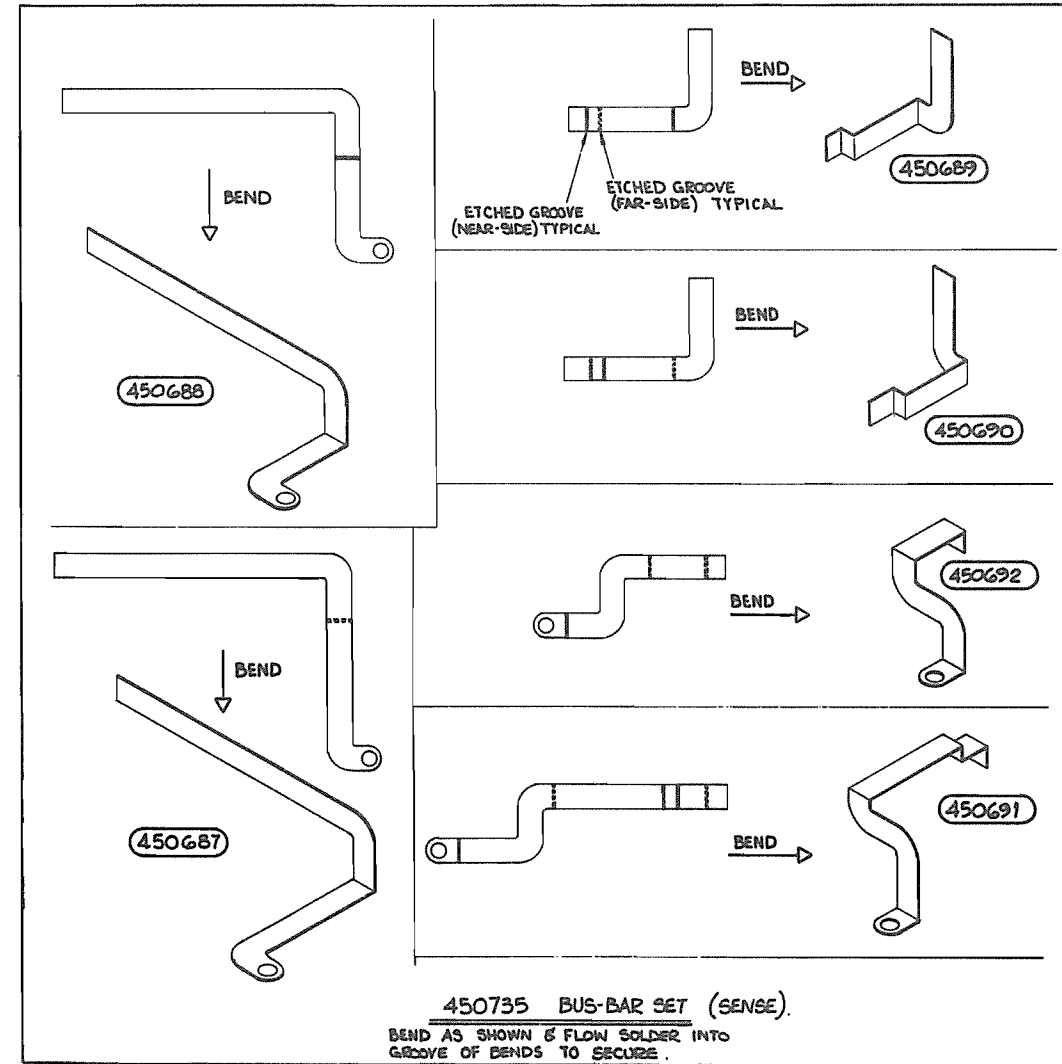
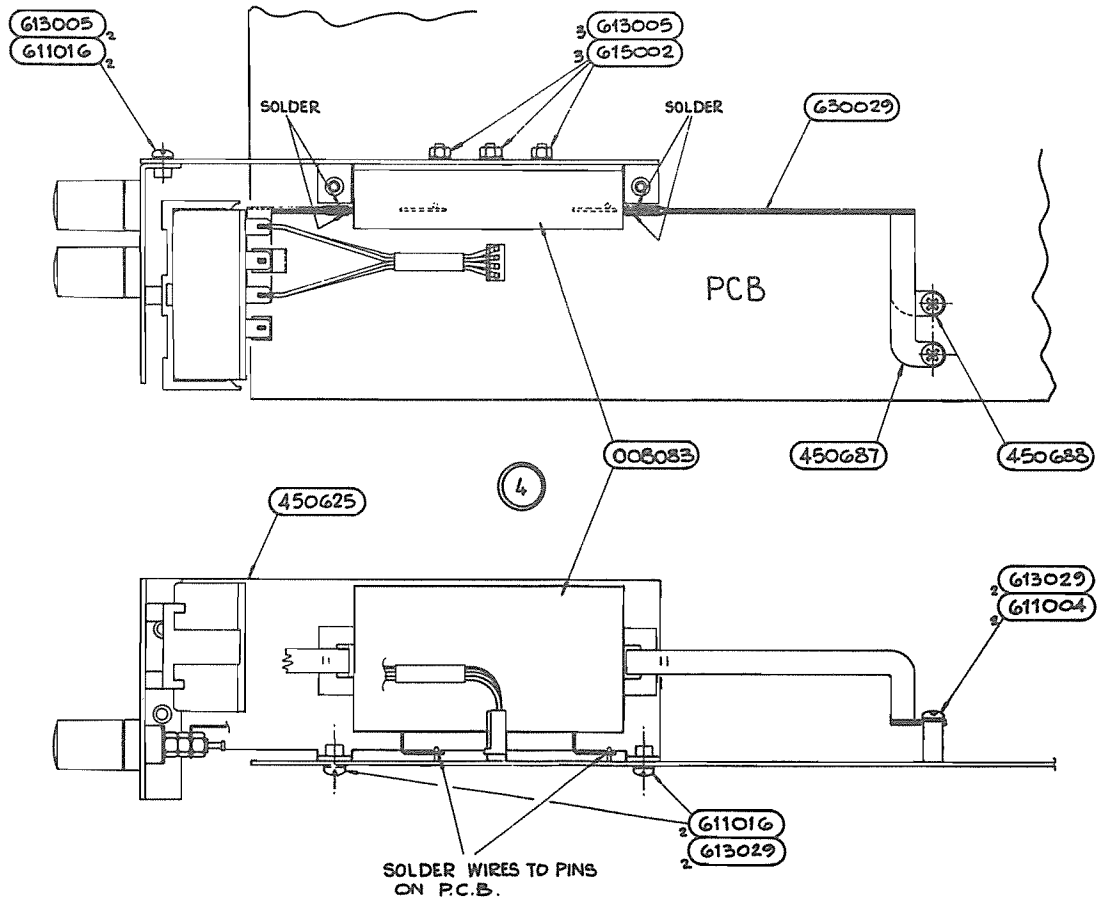
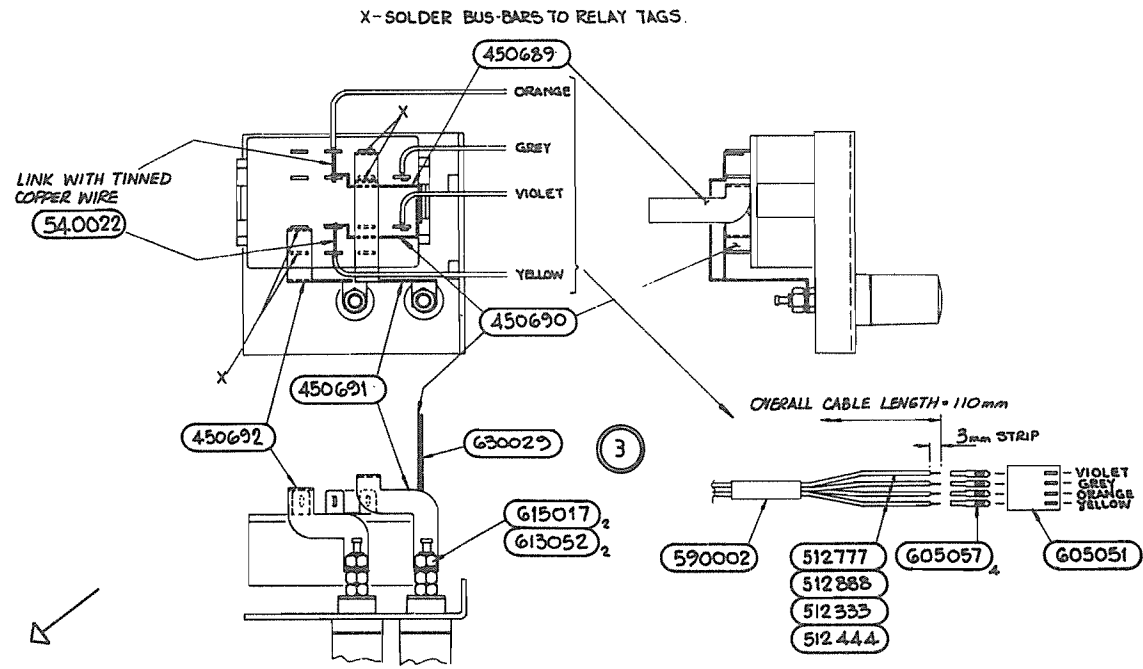
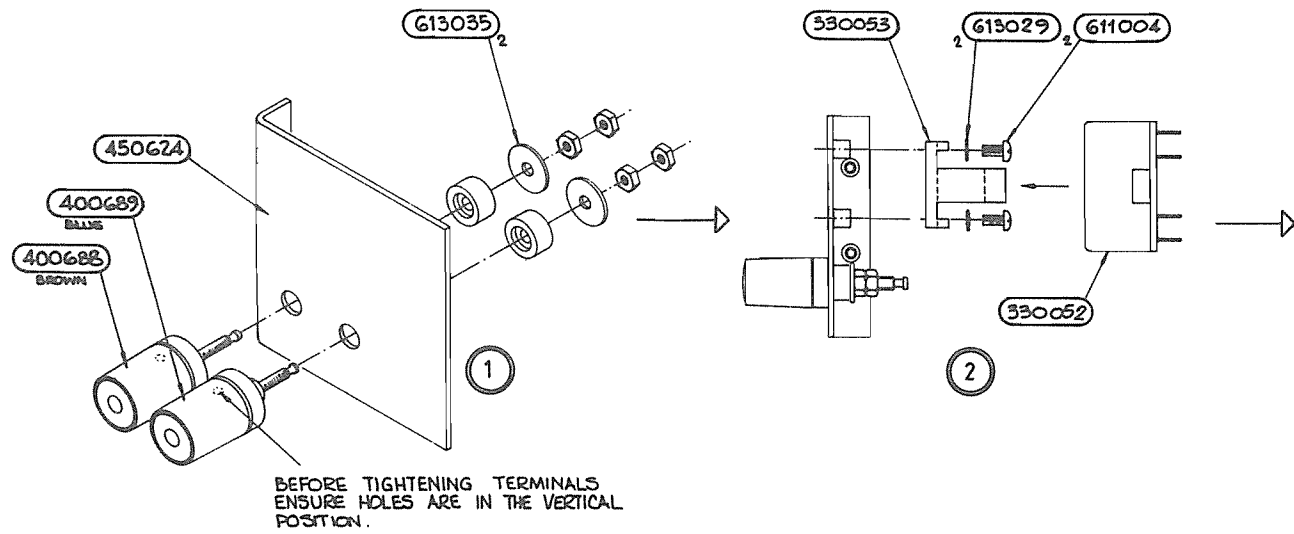

DESIG	PART NO	DESCRIPTION	PRINC MANUF	MANUF PART NUMBER	CLASS	UM	QUANTITY	CHANGES
R101	090177	RES NTWK 3K3 X 8 2%	BECKMAN	LO9-1-R3K3		EA	6	
R102	090105	RES PACK 100R X 4 2%	BECKMAN	LO8-3-R100		EA	2	
R103	013321	RES MF 3K32 1% .12W 50PPM	HOLSWORTHY	H8C	A	EA	6	
R104	090177	RES NTWK 3K3 X 8 2%	BECKMAN	LO9-1-R3K3		EA	-	
R105	090105	RES PACK 100R X 4 2%	BECKMAN	LO8-3-R100		EA	-	
R106	011002	RES MF 10K0 1% .12W 50PPM	HOLSWORTHY	H8C	A	EA	19	
R107	011002	RES MF 10K0 1% .12W 50PPM	HOLSWORTHY	H8C	A	EA	-	
R108	011003	RES MF 100K 1% .12W 50PPM	HOLSWORTHY	H8C	A	EA	11	
R109	013012	RES MF 30K1 1% .12W 50PPM	HOLSWORTHY	H8C	A	EA	4	
R110	011003	RES MF 100K 1% .12W 50PPM	HOLSWORTHY	H8C	A	EA	-	
R111	044753	RES MF 475K 1% .12W 50PPM	HOLSWORTHY	H8C	A	EA	1	
R202	019762	RES MF 97K6 1% .12W 50PPM	HOLSWORTHY	H8C	A	EA	1	
R203	012003	RES MF 200K 1% .12W 50PPM	HOLSWORTHY	H8C	A	EA	3	
R204	090177	RES NTWK 3K3 X 8 2%	BECKMAN	LO9-1-R3K3		EA	-	
R205	013321	RES MF 3K32 1% .12W 50PPM	HOLSWORTHY	H8C	A	EA	-	
R206	011053	RES MF 105K 1% .12W 50PPM	HOLSWORTHY	H8C	A	EA	1	
R208	090131	RES PACK 10K X 4 2%	BECKMAN	LO8-3-R10K		EA	5	
R209	090131	RES PACK 10K X 4 2%	BECKMAN	LO8-3-R10K		EA	-	
R210	090131	RES PACK 10K X 4 2%	BECKMAN	LO8-3-R10K		EA	-	
R211	090177	RES NTWK 3K3 X 8 2%	BECKMAN	LO9-1-R3K3		EA	-	
R212	090162	RES PACK 270R x 4 2%	AB	770-83-270R		EA	3	
R213	090162	RES PACK 270R x 4 2%	AB	770-83-270R		EA	-	
R214	090177	RES NTWK 3K3 X 8 2%	BECKMAN	LO9-1-R3K3		EA	-	
R215	013321	RES MF 3K32 1% .12W 50PPM	HOLSWORTHY	H8C	A	EA	-	
R216	013321	RES MF 3K32 1% .12W 50PPM	HOLSWORTHY	H8C	A	EA	-	
R217	012740	RES MF 274R 1% .12W 50PPM	HOLSWORTHY	H8C	A	EA	1	
R218	090162	RES PACK 270R x 4 2%	AB	770-83-270R		EA	-	
R219	018250	RES MF 825R 1% .12W 50PPM	HOLSWORTHY	H8C	A	EA	2	
R220	018250	RES MF 825R 1% .12W 50PPM	HOLSWORTHY	H8C	A	EA	-	
R222	090163	RES NTWK 10K x 8 2%	BECKMAN	LO9-1-R10K		EA	1	
R223	090131	RES PACK 10K X 4 2%	BECKMAN	LO8-3-R10K		EA	-	
R225	011002	RES MF 10K0 1% .12W 50PPM	HOLSWORTHY	H8C	A	EA	-	
R226	012211	RES MF 2K21 1% .12W 50PPM	HOLSWORTHY	H8C	A	EA	3	
R227	011301	RES MF 1K30 1% .12W 50PPM	HOLSWORTHY	H8C	A	EA	4	
R228	011301	RES MF 1K30 1% .12W 50PPM	HOLSWORTHY	H8C	A	EA	-	
R229	011301	RES MF 1K30 1% .12W 50PPM	HOLSWORTHY	H8C	A	EA	-	
R230	011301	RES MF 1K30 1% .12W 50PPM	HOLSWORTHY	H8C	A	EA	-	
R231	012211	RES MF 2K21 1% .12W 50PPM	HOLSWORTHY	H8C	A	EA	-	
R232	000478	RES CF 4R7 5% .25W	NEOHM	CFR25	A	EA	1	
R233	011001	RES MF 1K00 1% .12W 50PPM	HOLSWORTHY	H8C	A	EA	3	
R236	011500	RES MF 150R 1% .12W 50PPM	HOLSWORTHY	H8C	A	EA	6	
R237	090131	RES PACK 10K X 4 2%	BECKMAN	LO8-3-R10K		EA	-	
R238	090177	RES NTWK 3K3 X 8 2%	BECKMAN	LO9-1-R3K3		EA	-	
R239	011500	RES MF 150R 1% .12W 50PPM	HOLSWORTHY	H8C	A	EA	-	
R240	019312	RES MF 93K1 1% .12W 50PPM	HOLSWORTHY	H8C	A	EA	1	

DESIG	PART NO	DESCRIPTION	PRINC MANUF	MANUF PART NUMBER	CLASS	UM	QUANTITY	CHANGES
R241	011003	RES MF 100K 1% .12W 50PPM	HOLSWORTHY	H8C	A	EA	-	
R301	011001	RES MF 1K00 1% .12W 50PPM	HOLSWORTHY	H8C	A	EA	-	
R302	011001	RES MF 1K00 1% .12W 50PPM	HOLSWORTHY	H8C	A	EA	-	
R303	013573	RES MF 357K 1% .12W 50PPM	HOLSWORTHY	H8C	A	EA	3	
R305	011821	RES MF 1K82 1% .12W 50PPM	HOLSWORTHY	H8C	A	EA	6	
R306	011821	RES MF 1K82 1% .12W 50PPM	HOLSWORTHY	H8C	A	EA	-	
R307	011821	RES MF 1K82 1% .12W 50PPM	HOLSWORTHY	H8C	A	EA	-	
R308	011821	RES MF 1K82 1% .12W 50PPM	HOLSWORTHY	H8C	A	EA	-	
R309	011821	RES MF 1K82 1% .12W 50PPM	HOLSWORTHY	H8C	A	EA	-	
R310	011821	RES MF 1K82 1% .12W 50PPM	HOLSWORTHY	H8C	A	EA	-	
R311	012001	RES MF 2K00 1% .12W 50PPM	HOLSWORTHY	H8C	A	EA	3	
R312	012001	RES MF 2K00 1% .12W 50PPM	HOLSWORTHY	H8C	A	EA	-	
R313	00000F	RES FSV				EA	5	
R314	013651	RES MF 3K65 1% .12W 50PPM	HOLSWORTHY	H8C	A	EA	1	
R315	012213	RES MF 221K 1% .12W 50PPM	HOLSWORTHY	H8C	A	EA	1	
R316	011003	RES MF 100K 1% .12W 50PPM	HOLSWORTHY	H8C	A	EA	-	
R317	011101	RES MF 1K10 1% .12W 50PPM	HOLSWORTHY	H8C	A	EA	1	
R318	013922	RES MF 39K2 1% .12W 50PPM	HOLSWORTHY	H8C	A	EA	2	
R319	011003	RES MF 100K 1% .12W 50PPM	HOLSWORTHY	H8C	A	EA	-	
R320	011500	RES MF 150R 1% .12W 50PPM	HOLSWORTHY	H8C	A	EA	-	
R321	013161	RES MF 3K16 1% .12W 50PPM	HOLSWORTHY	H8C	A	EA	6	
R322	013161	RES MF 3K16 1% .12W 50PPM	HOLSWORTHY	H8C	A	EA	-	
R323	013012	RES MF 30K1 1% .12W 50PPM	HOLSWORTHY	H8C	A	EA	-	
R324	011002	RES MF 10K0 1% .12W 50PPM	HOLSWORTHY	H8C	A	EA	-	
R325	011373	RES MF 137K 1% .12W 50PPM	HOLSWORTHY	H8C	A	EA	1	
R326	011500	RES MF 150R 1% .12W 50PPM	HOLSWORTHY	H8C	A	EA	-	
R327	013321	RES MF 3K32 1% .12W 50PPM	HOLSWORTHY	H8C	A	EA	-	
R328	013012	RES MF 30K1 1% .12W 50PPM	HOLSWORTHY	H8C	A	EA	-	
R329	012001	RES MF 2K00 1% .12W 50PPM	HOLSWORTHY	H8C	A	EA	-	
R330	012211	RES MF 2K21 1% .12W 50PPM	HOLSWORTHY	H8C	A	EA	-	
R331	013321	RES MF 3K32 1% .12W 50PPM	HOLSWORTHY	H8C	A	EA	-	
R332	011002	RES MF 10K0 1% .12W 50PPM	HOLSWORTHY	H8C	A	EA	-	
R333	012003	RES MF 200K 1% .12W 50PPM	HOLSWORTHY	H8C	A	EA	-	
R334	013573	RES MF 357K 1% .12W 50PPM	HOLSWORTHY	H8C	A	EA	-	
R335	014321	RES MF 4K32 1% .12W 50PPM	HOLSWORTHY	H8C	A	EA	1	
R336	013161	RES MF 3K16 1% .12W 50PPM	HOLSWORTHY	H8C	A	EA	-	
R337	011331	RES MF 1K33 1% .12W 50PPM	HOLSWORTHY	H8C	A	EA	1	
R338	011002	RES MF 10K0 1% .12W 50PPM	HOLSWORTHY	H8C	A	EA	-	
R339	013011	RES MF 3K01 1% .12W 50PPM	HOLSWORTHY	H8C	A	EA	1	
R340	011500	RES MF 150R 1% .12W 50PPM	HOLSWORTHY	H8C	A	EA	-	
R341	011500	RES MF 150R 1% .12W 50PPM	HOLSWORTHY	H8C	A	EA	-	
R342	011003	RES MF 100K 1% .12W 50PPM	HOLSWORTHY	H8C	A	EA	-	
R343	011003	RES MF 100K 1% .12W 50PPM	HOLSWORTHY	H8C	A	EA	-	
R344	011161	RES MF 3K16 1% .12W 50PPM	HOLSWORTHY	H8C	A	EA	-	
R345	012003	RES MF 200K 1% .12W 50PPM	HOLSWORTHY	H8C	A	EA	-	

DESIG	PART NO	DESCRIPTION	PRINC MANUF	MANUF PART NUMBER	CLASS	UM	QUANTITY	CHANGES
R348	013573	RES MF 357K 1% .12W 50PPM	HOLSWORTHY	H8C	A	EA	-	
R349	017500	RES MF 750R 1% .12W 50PPM	HOLSWORTHY	H8C	A	EA	1	
R350	013161	RES MF 3K16 1% .12W 50PPM	HOLSWORTHY	H8C	A	EA	-	
R351	013012	RES MF 30K1 1% .12W 50PPM	HOLSWORTHY	H8C	A	EA	-	
R354	013161	RES MF 3K16 1% .12W 50PPM	HOLSWORTHY	H8C	A	EA	-	
R355	011003	RES MF 100K 1% .12W 50PPM	HOLSWORTHY	H8C	A	EA	-	
R356	011651	RES MF 1K65 1% .12W 50PPM	HOLSWORTHY	H8C	A	EA	1	
R357	011621	RES MF 1K62 1% .12W 50PPM	HOLSWORTHY	H8C	A	EA	1	
R358	015621	RES MF 5K62 1% .12W 50PPM	HOLSWORTHY	H8C	A	EA	1	
R359	063103	RES CT 10K HORZ S/T	BECKMAN	72P	A	EA	1	
R373	011002	RES MF 10K0 1% .12W 50PPM	HOLSWORTHY	H8C	A	EA	-	
R374	011092	RES MF 12K 1% .12W 50PPM	HOLSWORTHY	H8C	A	EA	-	
R375	011002	RES MF 10K0 1% .12W 50PPM	HOLSWORTHY	H8C	A	EA	-	
R376	011003	RES MF 100K 1% .12W 50PPM	HOLSWORTHY	H8C	A	EA	-	
R377	011002	RES MF 10K0 1% .12W 50PPM	HOLSWORTHY	H8C	A	EA	-	
R378	011002	RES MF 10K0 1% .12W 50PPM	HOLSWORTHY	H8C	A	EA	-	
R379	014751	RES MF 4K75 1% .12W 50PPM	HOLSWORTHY	H8C	A	EA	4	
R380	011002	RES MF 10K0 1% .12W 50PPM	HOLSWORTHY	H8C	A	EA	-	
R382	011002	RES MF 10K0 1% .12W 50PPM	HOLSWORTHY	H8C	A	EA	-	
R383	014751	RES MF 4K75 1% .12W 50PPM	HOLSWORTHY	H8C	A	EA	-	
R384	011002	RES MF 10K0 1% .12W 50PPM	HOLSWORTHY	H8C	A	EA	-	
R385	014751	RES MF 4K75 1% .12W 50PPM	HOLSWORTHY	H8C	A	EA	-	
R386	011002	RES MF 10K0 1% .12W 50PPM	HOLSWORTHY	H8C	A	EA	-	
R387	045624	RES MF 5K62 1% .12W 100PPM	STEATITE	MK2	A	EA	1	
R388	011002	RES MF 10K0 1% .12W 50PPM	HOLSWORTHY	H8C	A	EA	-	
R390	011003	RES MF 100K 1% .12W 50PPM	HOLSWORTHY	H8C	A	EA	-	
R392	011003	RES MF 100K 1% .12W 50PPM	HOLSWORTHY	H8C	A	EA	-	
R393	011002	RES MF 10K0 1% .12W 50PPM	HOLSWORTHY	H8C	A	EA	-	
R394	011002	RES MF 10K0 1% .12W 50PPM	HOLSWORTHY	H8C	A	EA	-	
R395	00000F	RES PSV			A	EA	-	
R396	00000F	RES PSV			A	EA	-	
R397	012212	RES MF 22K1 1% .12W 50PPM	HOLSWORTHY	H8C	A	EA	1	
R398	011002	RES MF 10K0 1% .12W 50PPM	HOLSWORTHY	H8C	A	EA	-	
R399	014751	RES MF 4K75 1% .12W 50PPM	HOLSWORTHY	H8C	A	EA	-	
R401	080142	RES FL 28K125 0.05%	VISHAY MANN	S102L	A	EA	4	
R402	080142	RES FL 28K125 0.05%	VISHAY MANN	S102L	A	EA	-	
R403	080142	RES FL 28K125 0.05%	VISHAY MANN	S102L	A	EA	-	
R404	080139	RES FL 56K25 0.05%	VISHAY MANN	S102L	A	EA	2	
R405	080138	RES FL 37K50 0.05%	VISHAY MANN	S102L	A	EA	2	
R406	080138	RES FL 37K50 0.05%	VISHAY MANN	S102L	A	EA	-	
R408	080137	RES FL 104K4 0.05%	VISHAY MANN	S102L	A	EA	2	
R409	00000F	RES PSV			A	EA	-	
R410	012102	RES MF 21K0 1% .12W 50PPM	HOLSWORTHY	H8C	A	EA	2	
R411	065012	RES CT 50K VERT M/T	BOURNS	3296W-50K	A	EA	1	
R412	012102	RES MF 21K0 1% .12W 50PPM	HOLSWORTHY	H8C	A	EA	-	

DESIG	PART NO	DESCRIPTION	PRINC MANUF	MANUF PART NUMBER	CLASS	UM	QUANTITY	CHANGES
R413	080137	RES FL 104K4 0.05%	VISHAY MANN	S102L	A	EA	-	
R414	012670	RES MF 267R 1% .12W 50PPM	HOLSWORTHY	H8C	A	EA	1	
R415	080141	RES FL 20K0 0.05%	VISHAY MANN	S102L	A	EA	1	
R416	00000F	RES PSV			A	EA	-	
R417	065009	RES CT 200K VERT M/T	BOURNS	3296W-200K	A	EA	1	
R419	013922	RES MF 39K2 1% .12W 50PPM	HOLSWORTHY	H8C	A	EA	-	
R420	013830	RES MF 383R 1% .12W 50PPM	HOLSWORTHY	H8C	A	EA	1	
R422	016811	RES MF 681R 1% .12W 50PPM	HOLSWORTHY	H8C	A	EA	1	
R423	046813	RES MF 681K 1% .12W 50PPM	HOLSWORTHY	H8C	A	EA	1	
R424	012800	RES MF 290R 1% .12W 50PPM	HOLSWORTHY	H8C	A	EA	1	
R431	016810	RES MF 681R 1% .12W 50PPM	HOLSWORTHY	H8C	A	EA	2	
R432	016810	RES MF 681R 1% .12W 50PPM	HOLSWORTHY	H8C	A	EA	-	
R433	012000	RES MF 200R 1% .12W 50PPM	HOLSWORTHY	H8C	A	EA	2	
R434	013923	RES MF 392K 1% .12W 50PPM	HOLSWORTHY	H8C	A	EA	1	
R435	041004	RES MF 1M00 1% .12W 50PPM	HOLSWORTHY	H8C	A	EA	1	
R436	080140	RES FL 289R3 0.05%	VISHAY MANN	S102L	A	EA	1	
R437	008082	RES WW 18R 5% 2.5W	WELWYN		A	EA	1	
R438	012000	RES MF 200R 1% .12W 50PPM	HOLSWORTHY	H8C	A	EA	-	
R439	014758	RES MF 47R5 1% .12W 50PPM	HOLSWORTHY	H8C	A	EA	2	
R440	014758	RES MF 47R5 1% .12W 50PPM	HOLSWORTHY	H8C	A	EA	-	
R441	080139	RES FL 56K25 0.05%	VISHAY MANN	S102L	A	EA	-	
R442	011008	RES MF 10R0 1% .12W 50PPM	HOLSWORTHY	H8C	A	EA	2	
R443	011008	RES MF 10R0 1% .12W 50PPM	HOLSWORTHY	H8C	A	EA	-	
R444	011000	RES MF 100R 1% .12W 50PPM	HOLSWORTHY	H8C	A	EA	1	
R445	080142	RES FL 28K125 0.05%	VISHAY MANN	S102L	A	EA	-	
R446	011503	RES MF 150K 1% .12W 50PPM	HOLSWORTHY	H8C	A	EA	1	
C501	000518	RES CF 5R1 5% .25W	NEOHM	CFR25	A	EA	1	
C101	100472	CAP CP 4N7F 10% 100V	PHILIPS	2222 630 19472	A	EA	10	
C102	100472	CAP CP 4N7F 10% 100V	PHILIPS	2222 630 19472	A	EA	-	
C103	100472	CAP CP 4N7F 10% 100V	PHILIPS	2222 630 19472	A	EA	-	
C104	100472	CAP CP 4N7F 10% 100V	PHILIPS	2222 630 19472	A	EA	-	
C105	100472	CAP CP 4N7F 10% 100V	PHILIPS	2222 630 19472	A	EA	-	
C106	100472	CAP CP 4N7F 10% 100V	PHILIPS	2222 630 19472	A	EA	-	
C107	100472	CAP CP 4N7F 10% 100V	PHILIPS	2222 630 19472	A	EA	-	
C108	100472	CAP CP 4N7F 10% 100V	PHILIPS	2222 630 19472	A	EA	-	
C109	100472	CAP CP 4N7F 10% 100V	PHILIPS	2222 630 19472	A	EA	-	
C110	100472	CAP CP 4N7F 10% 100V	PHILIPS	2222 630 19472	A	EA	-	
C111	150002	CAP DT 100F 20% 16V	AVX	TAP10M16F	A	EA	3	
C201	110035	CAP PE 220HF 20% 63V	WIMA	MKS2	A	EA	1	
C202	110041	CAP PE 100F 20% 100V	WIMA	PKS2	A	EA	2	
C203	150006	CAP DT 4U7F 200% 16V	AVX	TAP4K7M16F	A	EA	7	
C204	150006	CAP DT 4U7F 200% 16V	AVX	TAP4K7M16F	A	EA	-	
C205	104033	CAP NPWK 1NF X 7 20%	MURATA	432H	A	EA	3	
C206	104033	CAP NPWK 1NF X 7 20%	MURATA	432H	A	EA	-	
C207	104033	CAP NPWK 1NF X 7 20%	MURATA	432H	A	EA	-	

DESIG	PART NO	DESCRIPTION	PRINC MANUF	MANUF PART NUMBER	CLASS	UM	QUANTITY	CHANGES
C301	150006	CAP DT 4U7F 200% 16V	AVX	TAP4R7M16F	A	EA	-	
C307	110051	CAP PE 470NF 10% 63V	WIMA	MKS2		EA	6	
C308	110039	CAP PE 470NF 20% 63V	WIMA	MKS2		EA	2	
C309	150006	CAP DT 4U7F 200% 16V	AVX	TAP4R7M16F	A	EA	-	
C310	150006	CAP DT 4U7F 200% 16V	AVX	TAP4R7M16F	A	EA	-	
C311	110039	CAP PE 470NF 20% 63V	WIMA	MKS2		EA	-	
C312	100471	CAP CP 470PF 10% 100V	PHILIPS	2222 630 19471		EA	2	
C313	110051	CAP PE 470NF 10% 63V	WIMA	MKS2		EA	-	
C314	100471	CAP CP 470PF 10% 100V	PHILIPS	2222 630 19471		EA	-	
C316	110051	CAP PE 470NF 10% 63V	WIMA	MKS2		EA	-	
C317	150006	CAP DT 4U7F 200% 16V	AVX	TAP4R7M16F	A	EA	-	
C318	110051	CAP PE 470NF 10% 63V	WIMA	MKS2		EA	-	
C319	150002	CAP DT 10UF 20% 16V	AVX	TAP10M16F	A	EA	-	
C321	110051	CAP PE 470NF 10% 63V	WIMA	MKS2		EA	-	
C322	150002	CAP DT 10UF 20% 16V	AVX	TAP10M16F	A	EA	-	
C323	150015	CAP DT 10UF 20% 35V	AVX	TAP10M35F	A	EA	4	
C324	100151	CAP CP 150PF 2% 100V	PHILIPS	2222 683 34151		EA	1	
C325	150015	CAP DT 10UF 20% 35V	AVX	TAP10M35F	A	EA	-	
C326	110051	CAP PE 470NF 10% 63V	WIMA	MKS2		EA	-	
C401	104025	CAP CD 100NF +80%-20% 50V	SIEMENS	B37449		EA	8	
C402	140076-1	CAP VAR 16PF	TRONSER	SEE DRG	A	EA	2	
C403	104025	CAP CD 100NF +80%-20% 50V	SIEMENS	B37449		EA	-	
C404	104057	CAP CA 39PF 10% 100V	STREATITE	ASC 304		EA	1	
C406	10000F	CAP - PSV				EA	1	
C407	130089	CAP PS 4N7F 1% 160V	PHILIPS	425 44702		EA	2	
C408	110042	CAP PE 100NF 20% 63V	WIMA	MKS2		EA	2	
C409	110042	CAP PE 100NF 20% 63V	WIMA	MKS2		EA	-	
C410	150023	CAP DT 33UF 20% 25V	AVX	TAP33M25F	A	EA	4	
C411	140078	CAP PP 1NF 5% 100V	WIMA	FKP2		EA	1	
C412	150023	CAP DT 33UF 20% 25V	AVX	TAP33M25F	A	EA	-	
C413	104025	CAP CD 100NF +80%-20% 50V	SIEMENS	B37449		EA	-	
C414	130089	CAP PS 4N7F 1% 160V	PHILIPS	425 44702		EA	-	
C416	150024	CAP DT 47UF 20% 16V	AVX	TAP47M16F	A	EA	1	
C417	104025	CAP CD 100NF +80%-20% 50V	SIEMENS	B37449		EA	-	
C418	104025	CAP CD 100NF +80%-20% 50V	SIEMENS	B37449		EA	-	
C419	150023	CAP DT 33UF 20% 25V	AVX	TAP33M25F	A	EA	-	
C420	150023	CAP DT 33UF 20% 25V	AVX	TAP33M25F	A	EA	-	
C421	104025	CAP CD 100NF +80%-20% 50V	SIEMENS	B37449		EA	-	
C422	110041	CAP PE 10NF 20% 100V	WIMA	FKS2		EA	-	
C423	104025	CAP CD 100NF +80%-20% 50V	SIEMENS	B37449		EA	-	
C424	140076-1	CAP VAR 16PF	TRONSER	SEE DRG	A	EA	-	
C125	104058	CAP CA 33PF 10% 100V	STREATITE	ASC 304		EA	1	
C426	150016	CAP DT 1UF 20% 35V	AVX	TAP10M35F	A	EA	1	
C501	104025	CAP CD 100NF +80%-20% 50V	SIEMENS	B37449		EA	-	
C502	150006	CAP DT 4U7F 200% 16V	AVX	TAP4R7M16F	A	EA	-	

DESIG	PART NO	DESCRIPTION	PRINC MANUF	MANUF PART NUMBER	CLASS	UM	QUANTITY	CHANGES
C503	104026	CAP CD 47NF +50%-20% 50V	SIEMENS	B37449		EA	30	
C504	150017	CAP DT 100UF 20% 16V	AVX	TAP100M16F	A	EA	1	
C505	104026	CAP CD 47NF +50%-20% 50V	SIEMENS	B37449		EA	-	
C506	104026	CAP CD 47NF +50%-20% 50V	SIEMENS	B37449		EA	-	
C507	104026	CAP CD 47NF +50%-20% 50V	SIEMENS	B37449		EA	-	
C508	104026	CAP CD 47NF +50%-20% 50V	SIEMENS	B37449		EA	-	
C509	104026	CAP CD 47NF +50%-20% 50V	SIEMENS	B37449		EA	-	
C510	104026	CAP CD 47NF +50%-20% 50V	SIEMENS	B37449		EA	-	
C511	104026	CAP CD 47NF +50%-20% 50V	SIEMENS	B37449		EA	-	
C512	104026	CAP CD 47NF +50%-20% 50V	SIEMENS	B37449		EA	-	
C513	104026	CAP CD 47NF +50%-20% 50V	SIEMENS	B37449		EA	-	
C514	104026	CAP CD 47NF +50%-20% 50V	SIEMENS	B37449		EA	-	
C515	104026	CAP CD 47NF +50%-20% 50V	SIEMENS	B37449		EA	-	
C516	104026	CAP CD 47NF +50%-20% 50V	SIEMENS	B37449		EA	-	
C517	150020	CAP DT 10UF 20% 25V	AVX	TAP10M25F	A	EA	7	
C518	150020	CAP DT 10UF 20% 25V	AVX	TAP10M25F	A	EA	-	
C519	150020	CAP DT 10UF 20% 25V	AVX	TAP10M25F	A	EA	-	
C520	150020	CAP DT 10UF 20% 25V	AVX	TAP10M25F	A	EA	-	
C521	104026	CAP CD 47NF +50%-20% 50V	SIEMENS	B37449		EA	-	
C522	104026	CAP CD 47NF +50%-20% 50V	SIEMENS	B37449		EA	-	
C523	104026	CAP CD 47NF +50%-20% 50V	SIEMENS	B37449		EA	-	
C524	104026	CAP CD 47NF +50%-20% 50V	SIEMENS	B37449		EA	-	
C525	104026	CAP CD 47NF +50%-20% 50V	SIEMENS	B37449		EA	-	
C526	150015	CAP DT 10UF 20% 35V	AVX	TAP10M35F	A	EA	-	
C527	150015	CAP DT 10UF 20% 35V	AVX	TAP10M35F	A	EA	-	
C528	104026	CAP CD 47NF +50%-20% 50V	SIEMENS	B37449		EA	-	
C529	104026	CAP CD 47NF +50%-20% 50V	SIEMENS	B37449		EA	-	
C530	104026	CAP CD 47NF +50%-20% 50V	SIEMENS	B37449		EA	-	
C531	104026	CAP CD 47NF +50%-20% 50V	SIEMENS	B37449		EA	-	
C532	104026	CAP CD 47NF +50%-20% 50V	SIEMENS	B37449		EA	-	
C533	104026	CAP CD 47NF +50%-20% 50V	SIEMENS	B37449		EA	-	
C534	150020	CAP DT 10UF 20% 25V	AVX	TAP10M25F	A	EA	-	
C535	150020	CAP DT 10UF 20% 25V	AVX	TAP10M25F	A	EA	-	
C536	104026	CAP CD 47NF +50%-20% 50V	SIEMENS	B37449		EA	-	
C537	104026	CAP CD 47NF +50%-20% 50V	SIEMENS	B37449		EA	-	
C538	150020	CAP DT 10UF 20% 25V	AVX	TAP10M25F	A	EA	-	
C539	104026	CAP CD 47NF +50%-20% 50V	SIEMENS	B37449		EA	-	
C540	104026	CAP CD 47NF +50%-20% 50V	SIEMENS	B37449		EA	-	
C541	104026	CAP CD 47NF +50%-20% 50V	SIEMENS	B37449		EA	-	
C542	104026	CAP CD 47NF +50%-20% 50V	SIEMENS	B37449		EA	-	
C543	180024	CAP AE 10UF 63V	PHILIPS	030-38109	A	EA	2	
C544	180024	CAP AE 10UF 63V	PHILIPS	030-38109	A	EA	-	
C545	180044	CAP AE 220UF 40V	STREATITE	EKKMOODE 322G		EA	1	
D101	213006	DIODE 2N 5V 5W	UNITRODE	TVS505		EA	2	
D201	220044	DIODE LE RED HIEFF	GI	HLM-1700		EA	4	

DESIG	PART NO	DESCRIPTION	PRINC MANUF	MANUF PART NUMBER	CLASS	UM	QUANTITY	CHANGES
D202	200001	DIODE GP 75mA 75V	FAIRCHILD	1N4148		EA	15	
D203	200001	DIODE GP 75mA 75V	FAIRCHILD	1N4148		EA	-	
D204	200001	DIODE GP 75mA 75V	FAIRCHILD	1N4148		EA	-	
D205	200001	DIODE GP 75mA 75V	FAIRCHILD	1N4148		EA	-	
D206	200001	DIODE GP 75mA 75V	FAIRCHILD	1N4148		EA	-	
D301	214012	DIODE ZN 2V45 20PPM	FERRANTI	2N458		EA	3	
D303	214012	DIODE ZN 2V45 20PPM	FERRANTI	2N458		EA	-	
D304	200001	DIODE ZN 75mA 75V	FAIRCHILD	1N4148		EA	-	
D305	214012	DIODE ZN 2V45 20PPM	FERRANTI	2N458		EA	-	
D306	200001	DIODE GP 75mA 75V	FAIRCHILD	1N4148		EA	-	
D307	200001	DIODE GP 75mA 75V	FAIRCHILD	1N4148		EA	-	
D308	200001	DIODE GP 75mA 75V	FAIRCHILD	1N4148		EA	-	
D309	210047	DIODE ZN 4V7 400mW	PHILIPS	BZX79C4V7	A	EA	1	
D325	210240	DIODE ZN 24V 400mW	PHILIPS	BZX79C24	A	EA	1	
D326	220744	DIODE LE RED HIEFF	GI	HIMP-1700		EA	-	
D329	220044	DIODE LE RED HIEFF	GI	HIMP-1700		EA	-	
D330	220044	DIODE LE RED HIEFF	GI	HIMP-1700		EA	-	
D333	200001	DIODE GP 75mA 75V	FAIRCHILD	1N4148		EA	-	
D334	200001	DIODE GP 75mA 75V	FAIRCHILD	1N4148		EA	-	
D335	200001	DIODE GP 75mA 75V	FAIRCHILD	1N4148		EA	-	
D336	200001	DIODE GP 75mA 75V	FAIRCHILD	1N4148		EA	-	
D337	210056	DIODE ZN 5V6 400mW	PHILIPS	BZX79C5V6	A	EA	1	
D338	200001	DIODE GP 75mA 75V	FAIRCHILD	1N4148		EA	-	
D339	200001	DIODE GP 75mA 75V	FAIRCHILD	1N4148		EA	-	
D403	214013	DIODE ZN 6V2 5PPM	CENTRALAB	IN829A		EA	2	
D404	214013	DIODE ZN 6V2 5PPM	CENTRALAB	IN829A		EA	-	
D405	213009	DIODE ZN 15V 5W	UNITRODE	TVS515		EA	4	
D406	213009	DIODE ZN 15V 5W	UNITRODE	TVS515		EA	-	
D501	200002	DIODE GP 1A 50V	FAIRCHILD	1N4001		EA	3	
D502	213006	DIODE ZN 5V 5W	UNITRODE	TVS505		EA	-	
D503	200002	DIODE GP 1A 50V	FAIRCHILD	1N4001		EA	-	
D504	213009	DIODE ZN 15V 5W	UNITRODE	TVS515		EA	-	
D506	200002	DIODE GP 1A 50V	FAIRCHILD	1N4001		EA	-	
D507	213009	DIODE ZN 15V 5W	UNITRODE	TVS515		EA	-	
Q201	250004	TRAN PNP TO92	NATIONAL	2N3906		EA	4	
Q202	250004	TRAN PNP TO92	NATIONAL	2N3906		EA	-	
Q203	240006	TRAN NPN TO92	MOTOROLA	2N3904		EA	5	
Q304	240006	TRAN NPN TO92	MOTOROLA	2N3904		EA	-	
Q309	250004	TRAN PNP TO92	NATIONAL	2N3906		EA	-	
Q310	230036	TRAN JFET N CHAN	SILICONIX	J108		EA	3	
Q311	230078	TRAN MOSFET N CHAN	SILICONIX	BS170		EA	2	
Q314	240006	TRAN NPN TO92	MOTOROLA	2N3904		EA	-	
Q315	240006	TRAN NPN TO92	MOTOROLA	2N3904		EA	-	
Q316	240006	TRAN NPN TO92	MOTOROLA	2N3904		EA	-	

DESIG	PART NO	DESCRIPTION	PRINC MANUF	MANUF PART NUMBER	CLASS	UM	QUANTITY	CHANGES
Q401	230036	TRAN JFET N CHAN	SILICONIX	J108		EA	-	
Q402	230078	TRAN MOSFET N CHAN	SILICONIX	BS170		EA	-	
Q403	230036	TRAN JFET N CHAN	SILICONIX	J108		EA	-	
Q404	230002	TRAN JFET N-CHAN	SILICONIX	J304		EA	4	
Q405	230002	TRAN JFET N-CHAN	SILICONIX	J304		EA	-	
Q406	230002	TRAN JFET N-CHAN	SILICONIX	J304		EA	-	
U107	230002	TRAN JFET N-CHAN	SILICONIX	J304		EA	-	
U109	280137	IC DIG BUFF4 3S X2	PHILIPS	PC74HCT244P		EA	2	
U101	280086	IC DIG BUFF8 GP1B	MOTOROLA	MC1447		EA	1	
U102	00C00H	NOT FITTED				EA	2	
U103	00000H	NOT FITTED				EA	-	
U104	270068	IC DIG FLIP FLOP8 D 3S	NATIONAL	DM74LS374H		EA	2	
U105	400838-1	ASSY GAL 4600 INTFC	DATRON	SEE DRG		EA	1	
U106	280024	IC DIG BUFF6 3S	MOTOROLA	MC14503BCP		EA	4	
U107	280166	IC DIG NAND2 X4	TEXAS	SN74HCT00H	A	EA	3	
U108	270079	IC DIG FLIP FLOP4 D MR	NATIONAL	DM74LS175H		EA	1	
U109	280160	IC DIG FLIP FLOP D X2	TEXAS	SN74HCT74H		EA	1	
U110	280024	IC DIG BUFF6 3S	MOTOROLA	MC14503BCP		EA	-	
U111	280024	IC DIG BUFF6 3S	MOTOROLA	MC14503BCP		EA	-	
U112	280024	IC DIG BUFF6 3S	MOTOROLA	MC14503BCP		EA	-	
U201	290149	IC DIG CMOS TIMER	INTERSTIL	TCM7555 1PA		EA	1	
U202	280068	IC DIG MONO RTRIG PREC	MOTOROLA	MC14538BCP		EA	4	
U203	280137	IC DIG BUFF4 3S X2	PHILIPS	PC74HCT244P		EA	-	
U204	400839-1	ASSY GAL 4600 CNTRL	DATRON	SEE DRG		EA	1	
U205	270068	IC DIG FLIP FLOP8 D 3S	NATIONAL	DM74LS374H		EA	-	
U206	400840-1	ASSY GAL 4600 SEQHC	DATRON	SEE DRG		EA	1	
U207	280166	IC DIG NAND2 X4	TEXAS	SN74HCT00N	A	EA	-	
U208	290089	IC DIG DRIVER DARLINGTON X7	SPRAGUE/EXAR	ULN2003A/XR2203CP		EA	1	
U209	270071	IC DIG DECODER 2TO4 OC X2	NATIONAL	DM74LS156H	A	EA	1	
U210	220017-3	OPTO ISOL DUAL	ISOCOM	SEE DRG	A	EA	5	
U211	220017-3	OPTO ISOL DUAL	ISOCOM	SEE DRG	A	EA	-	
U212	220017-3	OPTO ISOL DUAL	ISOCOM	SEE DRG	A	EA	-	
U213	220017-3	OPTO ISOL DUAL	ISOCOM	SEE DRG	A	EA	-	
U214	220017-3	OPTO ISOL DUAL	ISOCOM	SEE DRG	A	EA	-	
U215	280166	IC DIG NAND2 X4	TEXAS	SN74HCT00H	A	EA	-	
U301	260075	IC LIN V COMP DUAL	NATIONAL	LM2903N		EA	2	
U302	260050	IC LIN OP AMP FET I/P DUAL 412	NATIONAL	LF412CN		EA	2	
U303	260091	IC LIN COMP QUAD	NATIONAL	LM339N		EA	2	
U304	280023	IC DIG NOR2 QUAD	MOTOROLA	MC14001UBCP		EA	2	
U305	280068	IC DIG MONO RTRIG PREC	MOTOROLA	MC14538BCP		EA	-	
U306	280068	IC DIG MONO RTRIG PREC	MOTOROLA	MC14538BCP		EA	-	
U308	260042	IC LIN OP AMP DUAL	SIGNETICS	NE5532N		EA	1	
U309	280068	IC DIG MONO RTRIG PREC	MOTOROLA	MC14538BCP		EA	-	
U310	260057	IC LIN OP AMP	SIGNETICS	NE5534N		EA	1	
U312	260091	IC LIN COMP QUAD	NATIONAL	LM339N		EA	-	

DESIG	PART NO	DESCRIPTION	PRINC MANUF	MANUF PART NUMBER	CLASS	UM	QUANTITY	CHANGES
U313	280023	IC DIG NOR2 QUAD	MOTOROLA	MC14001UBCP		EA	-	
U314	260050	IC LIN OP AMP FET I/P DUAL 412	NATIONAL	LF412CN		EA	-	
U315	260075	IC LIN V COMP DUAL	NATIONAL	LM2903N		EA	-	
U31E	290090	IC DIG DRIVER DARLINGTON X7	EXAR	XR2202CP	A	EA	2	
U319	280045	IC DIG NOR3 X3	MOTOROLA	MC14025BCP		EA	1	
U401	290090	IC DIG DRIVER DARLINGTON X7	EXAR	XR2202CP	A	EA	-	
U402	260121	IC LIN OP AMP FET IP	LT	LT1055ACH		EA	1	
U403	260082	IC LIN OP AMP CHOPPER	LINEAR TECHNOLOGY	LTC1052CN8		EA	1	
U404	260027	IC LIN OP AMP	FAIRCHILD	UA714HC		EA	1	
U405	260073	IC LIN OP AMP	NATIONAL	LF411CN		EA	1	
U501	260122	IC LIN REG +5V/0.5A	SGS	L387		EA	1	
U502	260094	IC LIN REG +15V 1A	SGS	L7815ACV	A	EA	1	
U503	260095	IC LIN REG -15V 1A	SGS	L7915ACV	A	EA	1	
RL401	33C036	RELAY 3PNO 1PNC	SDS	S3-24V		EA	1	
RL402	330031	RELAY 2PNO 2PNC	SDS	S2-24V		EA	1	
RL403	330017	RELAY 1FCO MINIATURE	OMRON	G2E184PHK12DCP5		EA	1	
L401	370001	CHOKE RF 10UH	SIGMA	SC10/25	A	EA	2	
L402	370001	CHOKE RF 10UH	SIGMA	SC10/25	A	EA	-	
J5	604088	PLUG PCB 20WAY .1" LP	3M	3592-6002	A	EA	1	
J10	604033	PLUG PCB 4-WAY .1"	MOLEX	22-29-2041		EA	5	
J12	604033	PLUG PCB 4-WAY .1"	MOLEX	22-29-2041		EA	-	
J22	604076	PLUG PCB 16-WAY .1" X.1" GRID	3M	3599-6002 UN		EA	1	
J4A	604098	PLUG PCB 4-WAY .1" 90DEG.	MOLEX	22-12-2044		EA	3	
J4B	604098	PLUG PCB 4-WAY .1" 90DEG.	MOLEX	22-12-2044		EA	-	
J4C	604098	PLUG PCB 4-WAY .1" 90DEG.	MOLEX	22-12-2044		EA	-	
J50	604033	PLUG PCB 4-WAY .1"	MOLEX	22-29-2041		EA	-	
J54	605169	SOCKET PCB 15 WAY D	AMP	164801-2		EA	1	
J8A	604033	PLUG PCB 4-WAY .1"	MOLEX	22-29-2041		EA	-	
J8B	604033	PLUG PCB 4-WAY .1"	MOLEX	22-29-2041		EA	-	
E401	620003	SOLDER PIN	HARWIN	H2105A01		EA	4	
E404	612024-1	STANDOFF M3 X 12.7	DATRON	SEE DRG		EA	1	
E405	612029-1	STANDOFF M3 X 12	DATRON	SEE DRG		EA	1	
E407	620003	SOLDER PIN	HARWIN	H2105A01		EA	-	
E408	620003	SOLDER PIN	HARWIN	H2105A01		EA	-	
E501	620003	SOLDER PIN	HARWIN	H2105A01		EA	-	
TL301	604046	PLUG PCB 3-WAY .1"	MOLEX	22-10-2031		EA	7	
TL302	604046	PLUG PCB 3-WAY .1"	MOLEX	22-10-2031		EA	-	
TL303	604046	PLUG PCB 3-WAY .1"	MOLEX	22-10-2031		EA	-	
TL304	604046	PLUG PCB 3-WAY .1"	MOLEX	22-10-2031		EA	-	
TL305	604046	PLUG PCB 3-WAY .1"	MOLEX	22-10-2031		EA	-	
TL401	604046	PLUG PCB 3-WAY .1"	MOLEX	22-10-2031		EA	-	
TL402	604046	PLUG PCB 3-WAY .1"	MOLEX	22-10-2031		EA	-	
TP101	620007	TEST POINT TERMINAL	MICROVAR	TYPE C30		EA	72	
TP102	620007	TEST POINT TERMINAL	MICROVAR	TYPE C30		EA	-	
TP103	620007	TEST POINT TERMINAL	MICROVAR	TYPE C30		EA	-	

DESIG	PART NO	DESCRIPTION	PRINC MANUF	MANUF PART NUMBER	CLASS	UM	QUANTITY	CHANGES
TP104	620007	TEST POINT TERMINAL	MICROVAR	TYPE C30		EA	-	
TP105	620007	TEST POINT TERMINAL	MICROVAR	TYPE C30		EA	-	
TP106	620007	TEST POINT TERMINAL	MICROVAR	TYPE C30		EA	-	
TP107	620007	TEST POINT TERMINAL	MICROVAR	TYPE C30		EA	-	
TP108	620007	TEST POINT TERMINAL	MICROVAR	TYPE C30		EA	-	
TP109	620007	TEST POINT TERMINAL	MICROVAR	TYPE C30		EA	-	
TP110	620007	TEST POINT TERMINAL	MICROVAR	TYPE C30		EA	-	
TP111	620007	TEST POINT TERMINAL	MICROVAR	TYPE C30		EA	-	
TP112	620007	TEST POINT TERMINAL	MICROVAR	TYPE C30		EA	-	
TP113	620007	TEST POINT TERMINAL	MICROVAR	TYPE C30		EA	-	
TP114	620007	TEST POINT TERMINAL	MICROVAR	TYPE C30		EA	-	
TP115	620007	TEST POINT TERMINAL	MICROVAR	TYPE C30		EA	-	
TP116	620007	TEST POINT TERMINAL	MICROVAR	TYPE C30		EA	-	
TP201	620007	TEST POINT TERMINAL	MICROVAR	TYPE C30		EA	-	
TP202	620007	TEST POINT TERMINAL	MICROVAR	TYPE C30		EA	-	
TP203	620007	TEST POINT TERMINAL	MICROVAR	TYPE C30		EA	-	
TP204	620007	TEST POINT TERMINAL	MICROVAR	TYPE C30		EA	-	
TP205	620007	TEST POINT TERMINAL	MICROVAR	TYPE C30		EA	-	
TP206	620007	TEST POINT TERMINAL	MICROVAR	TYPE C30		EA	-	
TP207	620007	TEST POINT TERMINAL	MICROVAR	TYPE C30		EA	-	
TP208	620007	TEST POINT TERMINAL	MICROVAR	TYPE C30		EA	-	
TP209	620007	TEST POINT TERMINAL	MICROVAR	TYPE C30		EA	-	
TP210	620007	TEST POINT TERMINAL	MICROVAR	TYPE C30		EA	-	
TP211	620007	TEST POINT TERMINAL	MICROVAR	TYPE C30		EA	-	
TP212	620007	TEST POINT TERMINAL	MICROVAR	TYPE C30		EA	-	
TP213	620007	TEST POINT TERMINAL	MICROVAR	TYPE C30		EA	-	
TP214	620007	TEST POINT TERMINAL	MICROVAR	TYPE C30		EA	-	
TP215	620007	TEST POINT TERMINAL	MICROVAR	TYPE C30		EA	-	
TP216	620007	TEST POINT TERMINAL	MICROVAR	TYPE C30		EA	-	
TP217	620007	TEST POINT TERMINAL	MICROVAR	TYPE C30		EA	-	
TP218	620007	TEST POINT TERMINAL	MICROVAR	TYPE C30		EA	-	
TP219	620007	TEST POINT TERMINAL	MICROVAR	TYPE C30		EA	-	
TP220	620007	TEST POINT TERMINAL	MICROVAR	TYPE C30		EA	-	
TP221	620007	TEST POINT TERMINAL	MICROVAR	TYPE C30		EA	-	
TP301	620007	TEST POINT TERMINAL	MICROVAR	TYPE C30		EA	-	
TP304	620007	TEST POINT TERMINAL	MICROVAR	TYPE C30		EA	-	
TP305	620007	TEST POINT TERMINAL	MICROVAR	TYPE C30		EA	-	
TP306	620007	TEST POINT TERMINAL	MICROVAR	TYPE C30		EA	-	
TP307	620007	TEST POINT TERMINAL	MICROVAR	TYPE C30		EA	-	
TP308	620007	TEST POINT TERMINAL	MICROVAR	TYPE C30		EA	-	
TP309	620007	TEST POINT TERMINAL	MICROVAR	TYPE C30		EA	-	
TP310	620007	TEST POINT TERMINAL	MICROVAR	TYPE C30		EA	-	
TP311	620007	TEST POINT TERMINAL	MICROVAR	TYPE C30		EA	-	
TP312	620007	TEST POINT TERMINAL	MICROVAR	TYPE C30		EA	-	
TP313	620007	TEST POINT TERMINAL	MICROVAR	TYPE C30		EA	-	

DESIG	PART NO	DESCRIPTION	PRINC MANUF	MANUF PART NUMBER	CLASS	UM	QUANTITY	CHANGES
TP314	620007	TEST POINT TERMINAL	MICROVAR	TYPE C30		EA	-	
TP401	620007	TEST POINT TERMINAL	MICROVAR	TYPE C30		EA	-	
TP402	620007	TEST POINT TERMINAL	MICROVAR	TYPE C30		EA	-	
TP403	620007	TEST POINT TERMINAL	MICROVAR	TYPE C30		EA	-	
TP404	620007	TEST POINT TERMINAL	MICROVAR	TYPE C30		EA	-	
TP406	620007	TEST POINT TERMINAL	MICROVAR	TYPE C30		EA	-	
TP407	620007	TEST POINT TERMINAL	MICROVAR	TYPE C30		EA	-	
TP408	620007	TEST POINT TERMINAL	MICROVAR	TYPE C30		EA	-	
TP409	620007	TEST POINT TERMINAL	MICROVAR	TYPE C30		EA	-	
TP410	620007	TEST POINT TERMINAL	MICROVAR	TYPE C30		EA	-	
TP411	620007	TEST POINT TERMINAL	MICROVAR	TYPE C30		EA	-	
TP412	620007	TEST POINT TERMINAL	MICROVAR	TYPE C30		EA	-	
TP413	620007	TEST POINT TERMINAL	MICROVAR	TYPE C30		EA	-	
TP414	620007	TEST POINT TERMINAL	MICROVAR	TYPE C30		EA	-	
TP415	620007	TEST POINT TERMINAL	MICROVAR	TYPE C30		EA	-	
TP501	620007	TEST POINT TERMINAL	MICROVAR	TYPE C30		EA	-	
TP502	620007	TEST POINT TERMINAL	MICROVAR	TYPE C30		EA	-	
TP503	620007	TEST POINT TERMINAL	MICROVAR	TYPE C30		EA	-	
TP504	620007	TEST POINT TERMINAL	MICROVAR	TYPE C30		EA	-	
TP506	620007	TEST POINT TERMINAL	MICROVAR	TYPE C30		EA	-	
TP507	620007	TEST POINT TERMINAL	MICROVAR	TYPE C30		EA	-	
TP508	620007	TEST POINT TERMINAL	MICROVAR	TYPE C30		EA	-	
TP509	620007	TEST POINT TERMINAL	MICROVAR	TYPE C30		EA	-	
TP510	620007	TEST POINT TERMINAL	MICROVAR	TYPE C30		EA	-	
F501	920208	FUSE 1A 20MM LBC(F)	BELLING LEE	L1427B/1A		EA	3	
F502	920206	FUSE 1A 20MM LBC(F)	BELLING LEE	L1427B/1A		EA	-	
F503	920208	FUSE 1A 20MM LBC(F)	BELLING LEE	L1427B/1A		EA	-	
	008083-1	RES WW (10A SHUNT)		SEE DRG		EA	1	
	330052	RELAY POWER 4PCO	SDS	SP4-DC24V		EA	1	
	330053	RELAY RETAINING CLIP	SDS	SP-MA		EA	1	
	400688-1	ASSY SAFETY TERMINAL BRN	DATRON	SEE DRG		EA	1	
	400689-1	ASSY SAFETY TERMINAL BLUE	DATRON	SEE DRG		EA	1	
	410415-B	PCB SENSE 4600		SEE DRG		EA	1	
	420098	LABEL SERIAL/ASSY No.	RS	554-793		EA	1	
	420112-1	LABEL SSD WARNING 12 X 12mm		SEE DRG	A	EA	1	
	450624-1	MTG BRKT OUTPUT TERMINAL 4600		SEE DRG		EA	1	
	450625-1	MTG BRKT RESISTOR 4600		SEE DRG		EA	1	
	450727-1	INSULATION PAD	DATRON	SEE DRG		EA	1	
	450735-1	BUS BAR SET 4600		SEE DRG		EA	1	
	512333	WIRE 7/.2 PTFE 1KV ORANGE	BSG210	TYPE C		AR	1	
	512444	WIRE 7/.2 PTFE 1KV YEL	BSG210	TYPE C		AR	1	
	512777	WIRE 7/.2 PTFE 1KV YIO	BSG210	TYPE C		AR	1	
	512888	WIRE 7/.2 PTFE 1KV GRV	BSG210	TYPE C		AR	1	
	540006	WIRE 1/.4 BLACK PTFE 250V	BSG210	TYPE A		AR	1	
	540022	WIRE 20SWG TINNED CU.	R. S. COMPONENTS	355-063		AR	1	

DESIG	PART NO	DESCRIPTION	PRINC MANUF	MANUF PART NUMBER	CLASS	UM	QUANTITY	CHANGES
	590002	SLEEVE NP 3 X 25MM BLK	HELLERMANN	H30		EA	1	
	590004	SLEEVE PTFE 1mm BLK	HELLERMANN	PE10		AR	1	
	602001	TERMINAL FSV	MOLEX	02-04-5114		EA	12	
	605051	HOUSING 4WAY	MOLEX	6471 SERIES 22-01-20		EA	1	
	605057	CRIMP TERMINAL GD PL	MOLEX	08-56-0120		EA	4	
	605059	SOCKET PCB 8-WAY DIL	JERMYN	J23-18008	A	EA	14	
	605060	SOCKET PCB 14-WAY DIL	JERMYN	J23-18014	A	EA	9	
	605061	SOCKET PCB 16-WAY DIL	JERMYN	J23-18016	A	EA	13	
	605064	SOCKET PCB 24 WAY DIL	JERMYN	J23-18024	A	EA	1	
	605070	SOCKET PCB 20-WAY DIL	JERMYN	J23-18020	A	EA	6	
	611004	SCREW M3 X 6 POZIPAN SZP				EA	4	
	611006	SCREW M3 X 10 POZIPAN SZP				EA	2	
	611016	SCREW M3 X 8 POZIPAN SZP				EA	7	
	613005	WASHER M3 INT SHAKEPROOF				EA	5	
	613029	WASHER M3 WAVY SS				EA	11	
	613035-1	WASHER LARGE M4		SEE DRG		EA	2	
	613052	WASHER M4 WAVY SS				EA	2	
	615002	NUT M3 FULL SZP				EA	8	
	615017	NUT LOCK M4 BNP				EA	2	
	618004	PAD MNTG TO16	JERMYN	TO18-008D		EA	3	
	630024	BEAD CERAMIC 16 SWG	PARK ROYAL PORCELAIN	No2		EA	12	
	630029	TAPE 1/4" X 1/32" DBL.SIDED	3M	4032		AR	1	
	630036	BEAD CERAMIC 18 SWG	PARK ROYAL PORCELAIN	No1		EA	4	
	630243	BEAD GLASS 2.4 X 0.81 X 1.8	MAVSOL (PREFORMS) LT	M5363B/3		EA	04	
	900004	SILICONE RUBBER COMPOUND	PS	555-588		AR	1	
	920126	FUSE HOLDER PCB 20MM	BELLING LEE	L1426		EA	3	
	920152	HEATSINK TO-220	AAVID	54258-TT		EA	3	
ST1	99908S	STAR-POINT 08 NOT FITTED				EA	8	
ST2	99908S	STAR-POINT 08 NOT FITTED				EA	-	
ST3	99916S	STAR-POINT 16 NOT FITTED				EA	1	
ST4	99908S	STAR-POINT 08 NOT FITTED				EA	-	
ST5	99908S	STAR-POINT 08 NOT FITTED				EA	-	
ST6	99908S	STAR-POINT 08 NOT FITTED				EA	-	
ST7	99908S	STAR-POINT 08 NOT FITTED				EA	-	
ST8	99908S	STAR-POINT 08 NOT FITTED				EA	-	
ST9	99908S	STAR-POINT 08 NOT FITTED				EA	-	

End

DESIG	PART NO	DESCRIPTION	PRINC MANUF	MANUF PART NUMBER	CLASS	UM	QUANTITY	CHANGES
R101	012001	RES MF 2K00 1% .12W 50PPM	HOLSWORTHY	H8C	A	EA	4	
R102	012001	RES MF 2K00 1% .12W 50PPM	HOLSWORTHY	H8C	A	EA	-	
R103	011500	RES MF 150R 1% .12W 50PPM	HOLSWORTHY	H8C	A	EA	2	
R104	012210	RES MF 221R 1% .12W 50PPM	HOLSWORTHY	H8C	A	EA	2	
R105	012001	RES MF 2K00 1% .12W 50PPM	HOLSWORTHY	H8C	A	EA	-	
R106	015118	RES MF 51R1 1% .12W 50PPM	HOLSWORTHY	H8C	A	EA	2	
R107	012001	RES MF 2K00 1% .12W 50PPM	HOLSWORTHY	H8C	A	EA	-	
R108	016810	RES MF 681R 1% .12W 50PPM	HOLSWORTHY	H8C	A	EA	2	
R109	016810	RES MF 681R 1% .12W 50PPM	HOLSWORTHY	H8C	A	EA	-	
R110	012210	RES MF 221R 1% .12W 50PPM	HOLSWORTHY	H8C	A	EA	-	
R111	011500	RES MF 150R 1% .12W 50PPM	HOLSWORTHY	H8C	A	EA	-	
R112	000150	RES CF 15R 5% .25W	NEOHM	CFR25	A	EA	6	
R113	050085	RES MF 10R 1% 0.75W 100PPM	WELWYN	MFR5	A	EA	8	
R114	011622	RES MF 16K2 1% .12W 50PPM	HOLSWORTHY	H8C	A	EA	18	
R115	008021	RES WW 0R47 5% 2.5W	WELWYN	W21-0R47	A	EA	18	
R116	011622	RES MF 16K2 1% .12W 50PPM	HOLSWORTHY	H8C	A	EA	-	
R117	008021	RES WW 0R47 5% 2.5W	WELWYN	W21-0R47	A	EA	-	
R118	011622	RES MF 16K2 1% .12W 50PPM	HOLSWORTHY	H8C	A	EA	-	
R119	008021	RES WW 0R47 5% 2.5W	WELWYN	W21-0R47	A	EA	-	
R120	000150	RES CF 15R 5% .25W	NEOHM	CFR25	A	EA	-	
R121	050085	RES MF 10R 1% 0.75W 100PPM	WELWYN	MFR5	A	EA	-	
R122	011622	RES MF 16K2 1% .12W 50PPM	HOLSWORTHY	H8C	A	EA	-	
R123	008021	RES WW 0R47 5% 2.5W	WELWYN	W21-0R47	A	EA	-	
R124	011622	RES MF 16K2 1% .12W 50PPM	HOLSWORTHY	H8C	A	EA	-	
R125	008021	RES WW 0R47 5% 2.5W	WELWYN	W21-0R47	A	EA	-	
R126	011622	RES MF 16K2 1% .12W 50PPM	HOLSWORTHY	H8C	A	EA	-	
R127	008021	RES WW 0R47 5% 2.5W	WELWYN	W21-0R47	A	EA	-	
R128	000150	RES CF 15R 5% .25W	NEOHM	CFR25	A	EA	-	
R129	050085	RES MF 10R 1% 0.75W 100PPM	WELWYN	MFR5	A	EA	-	
R130	011622	RES MF 16K2 1% .12W 50PPM	HOLSWORTHY	H8C	A	EA	-	
R131	008021	RES WW 0R47 5% 2.5W	WELWYN	W21-0R47	A	EA	-	
R132	011622	RES MF 16K2 1% .12W 50PPM	HOLSWORTHY	H8C	A	EA	-	
R133	008021	RES WW 0R47 5% 2.5W	WELWYN	W21-0R47	A	EA	-	
R134	011622	RES MF 16K2 1% .12W 50PPM	HOLSWORTHY	H8C	A	EA	-	
R135	008021	RES WW 0R47 5% 2.5W	WELWYN	W21-0R47	A	EA	-	
R136	000150	RES CF 15R 5% .25W	NEOHM	CFR25	A	EA	-	
R137	050085	RES MF 10R 1% 0.75W 100PPM	WELWYN	MFR5	A	EA	-	
R138	011622	RES MF 16K2 1% .12W 50PPM	HOLSWORTHY	H8C	A	EA	-	
R139	008021	RES WW 0R47 5% 2.5W	WELWYN	W21-0R47	A	EA	-	
R140	011622	RES MF 16K2 1% .12W 50PPM	HOLSWORTHY	H8C	A	EA	-	
R141	008021	RES WW 0R47 5% 2.5W	WELWYN	W21-0R47	A	EA	-	
R142	011622	RES MF 16K2 1% .12W 50PPM	HOLSWORTHY	H8C	A	EA	-	
R143	008021	RES WW 0R47 5% 2.5W	WELWYN	W21-0R47	A	EA	-	
R144	000150	RES CF 15R 5% .25W	NEOHM	CFR25	A	EA	-	
R145	050085	RES MF 10R 1% 0.75W 100PPM	WELWYN	MFR5	A	EA	-	

DESIG	PART NO	DESCRIPTION	PRINC MANUF	MANUF PART NUMBER	CLASS	UM	QUANTITY	CHANGES
R146	011622	RES MF 16K2 1% .12W 50PPM	HOLSWORTHY	H8C	A	EA	-	
R147	008021	RES WW 0R47 5% 2.5W	WELWYN	W21-0R47	A	EA	-	
R148	011622	RES MF 16K2 1% .12W 50PPM	HOLSWORTHY	H8C	A	EA	-	
R149	008021	RES WW 0R47 5% 2.5W	WELWYN	W21-0R47	A	EA	-	
R150	011622	RES MF 16K2 1% .12W 50PPM	HOLSWORTHY	H8C	A	EA	-	
R151	008021	RES WW 0R47 5% 2.5W	WELWYN	W21-0R47	A	EA	-	
R152	000150	RES CF 15R 5% .25W	NEOHM	CFR25	A	EA	-	
R153	050085	RES MF 10R 1% 0.75W 100PPM	WELWYN	MFR5	A	EA	-	
R154	011622	RES MF 16K2 1% .12W 50PPM	HOLSWORTHY	H8C	A	EA	-	
R155	008021	RES WW 0R47 5% 2.5W	WELWYN	W21-0R47	A	EA	-	
R156	011622	RES MF 16K2 1% .12W 50PPM	HOLSWORTHY	H8C	A	EA	-	
R157	008021	RES WW 0R47 5% 2.5W	WELWYN	W21-0R47	A	EA	-	
R158	011622	RES MF 16K2 1% .12W 50PPM	HOLSWORTHY	H8C	A	EA	-	
R159	008021	RES WW 0R47 5% 2.5W	WELWYN	W21-0R47	A	EA	-	
R160	090155-1	THERMISTOR NTC 10K	DALE-ACI	SEE DRG	A	EA	1	
R161	000102	RES CF 1K0 5% .25W	NEOHM	CFR25	A	EA	2	
R162	000102	RES CF 1K0 5% .25W	NEOHM	CFR25	A	EA	-	
R163	050085	RES MF 10R 1% 0.75W 100PPM	WELWYN	MFR5	A	EA	-	
R164	050085	RES MF 10R 1% 0.75W 100PPM	WELWYN	MFR5	A	EA	-	
R165	015118	RES MF 51R1 1% .12W 50PPM	HOLSWORTHY	H8C	A	EA	-	
C101	120029	CAP PC 6N8F 20% 100V	WIMA	FKC2	A	EA	2	
C102	120029	CAP PC 6N8F 20% 100V	WIMA	FKC2	A	EA	-	
C103	104055	CAP CER MULTILAYER 3U3F 50V	SPRAUGE	3C2025U335H050B	A	EA	1	
C104	180006	CAP AE 47UF 25V	PHILIPS	016-16479	A	EA	1	
C107	104026	CAP CD 47NF +50%-20% 50V	SIEMENS	B37449	A	EA	2	
C108	104026	CAP CD 47NF +50%-20% 50V	SIEMENS	B37449	A	EA	-	
C109	150015	CAP DT 10UF 20% 35V	AVX	TAP10M35F	A	EA	4	
C110	150015	CAP DT 10UF 20% 35V	AVX	TAP10M35F	A	EA	-	
C113	150015	CAP DT 10UF 20% 35V	AVX	TAP10M35F	A	EA	-	
C114	150015	CAP DT 10UF 20% 35V	AVX	TAP10M35F	A	EA	-	
C115	110042	CAP PE 100NF 20% 63V	WIMA	MKS2	A	EA	1	
D101	200006	DIODE GP 1A 600V	FAIRCHILD	1N4005	A	EA	2	
D102	200006	DIODE GP 1A 600V	FAIRCHILD	1N4005	A	EA	-	
Q101	230050	TRAN JFET I LIM 2m4A	SILICONIX	J508	A	EA	1	
Q102	250004	TRAN PNP TO92	NATIONAL	2N3906	A	EA	2	
Q103	240006	TRAN NPN TO92	MOTOROLA	2N3904	A	EA	2	
Q104	250004	TRAN PNP TO92	NATIONAL	2N3906	A	EA	-	
Q105	240006	TRAN NPN TO92	MOTOROLA	2N3904	A	EA	-	
Q107	250021	TRAN PNP	MOTOROLA	BD140	A	EA	3	
Q108	250032	TRAN PNP TO220	MOTOROLA	MJE15029	A	EA	9	
Q109	250032	TRAN PNP TO220	MOTOROLA	MJE15029	A	EA	-	
Q110	250032	TRAN PNP TO220	MOTOROLA	MJE15029	A	EA	-	
Q111	250021	TRAN PNP	MOTOROLA	BD140	A	EA	-	
Q112	250032	TRAN PNP TO220	MOTOROLA	MJE15029	A	EA	-	
Q113	250032	TRAN PNP TO220	MOTOROLA	MJE15029	A	EA	-	

DESIG	PART NO	DESCRIPTION	PRINC MANUF	MANUF PART NUMBER	CLASS	QM	QUANTITY	CHANGES
Q114	250032	TRAN PNP T0220	MOTOROLA	MJE15029		EA	-	
Q115	250021	TRAN PNP	MOTOROLA	BD140	A	EA	-	
Q116	250032	TRAN PNP T0220	MOTOROLA	MJE15029		EA	-	
Q117	250032	TRAN PNP T0220	MOTOROLA	MJE15029		EA	-	
Q118	250032	TRAN PNP T0220	MOTOROLA	MJE15029		EA	-	
Q119	240031	TRAN NPN	MOTOROLA	BD139	A	EA	3	
Q120	240047	TRAN NPN T0220	MOTOROLA	MJE15028		EA	9	
Q121	240047	TRAN NPN T0220	MOTOROLA	MJE15028		EA	-	
Q122	240047	TRAN NPN T0220	MOTOROLA	MJE15028		EA	-	
Q123	240031	TRAN NPN	MOTOROLA	BD139	A	EA	-	
Q124	240047	TRAN NPN T0220	MOTOROLA	MJE15028		EA	-	
Q125	240047	TRAN NPN T0220	MOTOROLA	MJE15028		EA	-	
Q126	240047	TRAN NPN T0220	MOTOROLA	MJE15028		EA	-	
Q127	240031	TRAN NPN	MOTOROLA	BD139	A	EA	-	
Q128	240047	TRAN NPN T0220	MOTOROLA	MJE15028		EA	-	
Q129	240047	TRAN NPN T0220	MOTOROLA	MJE15028		EA	-	
Q130	240047	TRAN NPN T0220	MOTOROLA	MJE15028		EA	-	
M101	260065	IC LIN OP AMP	PMI	OP27FZ		EA	1	
J21	400900-1	ASSY RIBBON CABLE 4600	DATRON	SEE DRG		EA	1	
E26	612026-1	STANDOFF M3 X 6	DATRON	SEE DRG		EA	1	
E27	612025-1	STANDOFF M3 X 5	DATRON	SEE DRG		EA	1	
E29	612004-1	STANDOFF M3 X 4	DATRON	SEE DRG		EA	1	
	410414-B	PCB OUTPUT 4600		SEE DRG		EA	1	
	450635-1	HEATSINK 4600		SEE DRG		EA	2	
	450702-1	THERMAL PAD NON -INSULATING		SEE DRG		EA	2	
	540002	WIRE 1/.7 TINNED COPPER	BS4109	22SWG		AR	1	
	590004	SLEEVE PTFE 1mm BLK	HELLERMAN	FE10		AR	1	
	605059	SOCKET PCB 8-WAY DIL	JERMYN	J23-18008	A	EA	1	
	611017	SCREW M3 X 16 POZIPAN SZP				EA	10	
	611027	SCREW M3 X 20 POZIPAN SZP				EA	3	
	612053	SPACER MALE/FEMALE X 15mm	HARWIN	R6342-02		EA	1	
	613005	WASHER M3 INT SHAKEPROOF				EA	1	
	613029	WASHER M3 WAVY SS				EA	26	
	615002	NUT M3 FULL SZP				EA	13	
	630243	BEAD GLASS 2.4 X 0.81 X 1.8	MANSOL (PREFORMS) LT	M5363B/3		EA	4	

End

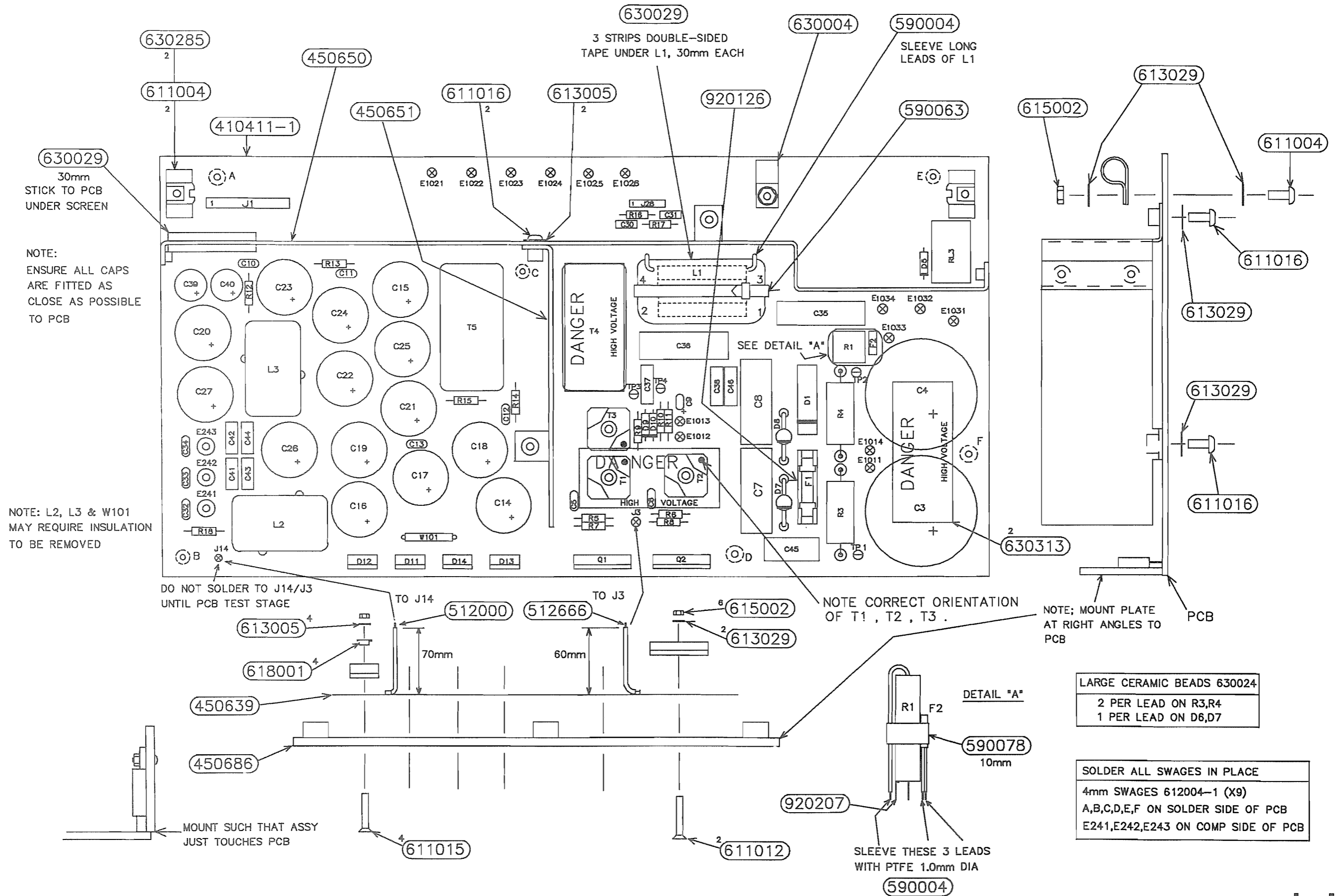

30mm
STICK TO PCB
UNDER SCREEN

NOTE:
ENSURE ALL CAPS
ARE FITTED AS
CLOSE AS POSSIBLE
TO PCB

NOTE: L2, L3 & W101
MAY REQUIRE INSULATION
TO BE REMOVED

DO NOT SOLDER TO J14/J3
UNTIL PCB TEST STAGE

NOTE CORRECT ORIENTATION
OF T1, T2, T3.

NOTE: MOUNT PLATE
AT RIGHT ANGLES TO
PCB

LARGE CERAMIC BEADS 630024
2 PER LEAD ON R3,R4
1 PER LEAD ON D6,D7

SOLDER ALL SWAGES IN PLACE
4mm SWAGES 612004-1 (X9)
A,B,C,D,E,F ON SOLDER SIDE OF PCB
E241,E242,E243 ON COMP SIDE OF PCB

SLEEVE THESE 3 LEADS
WITH PTFE 1.0mm DIA

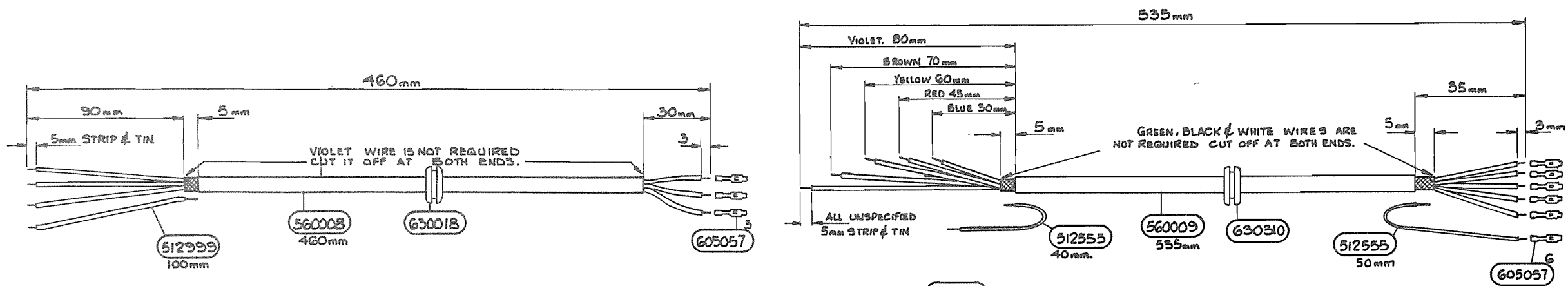

4WAY CABLE WIRE ENDS

YELLOW TO E1014
 WHITE TO E1011
 GREEN TO E1012
 ORANGE TO E1013

8WAY CABLE WIRE ENDS

VIOLET TO E1021
 BROWN TO E1022
 YELLOW TO E1023
 RED TO E1024
 BLUE TO E1025
 GREEN TO E1026
 (SCREEN CONNECTION)

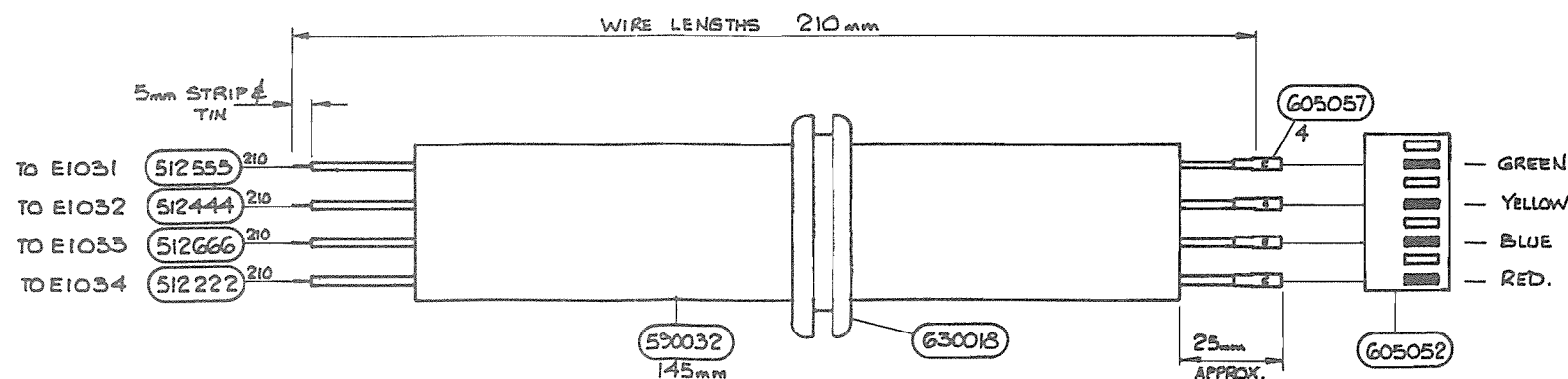
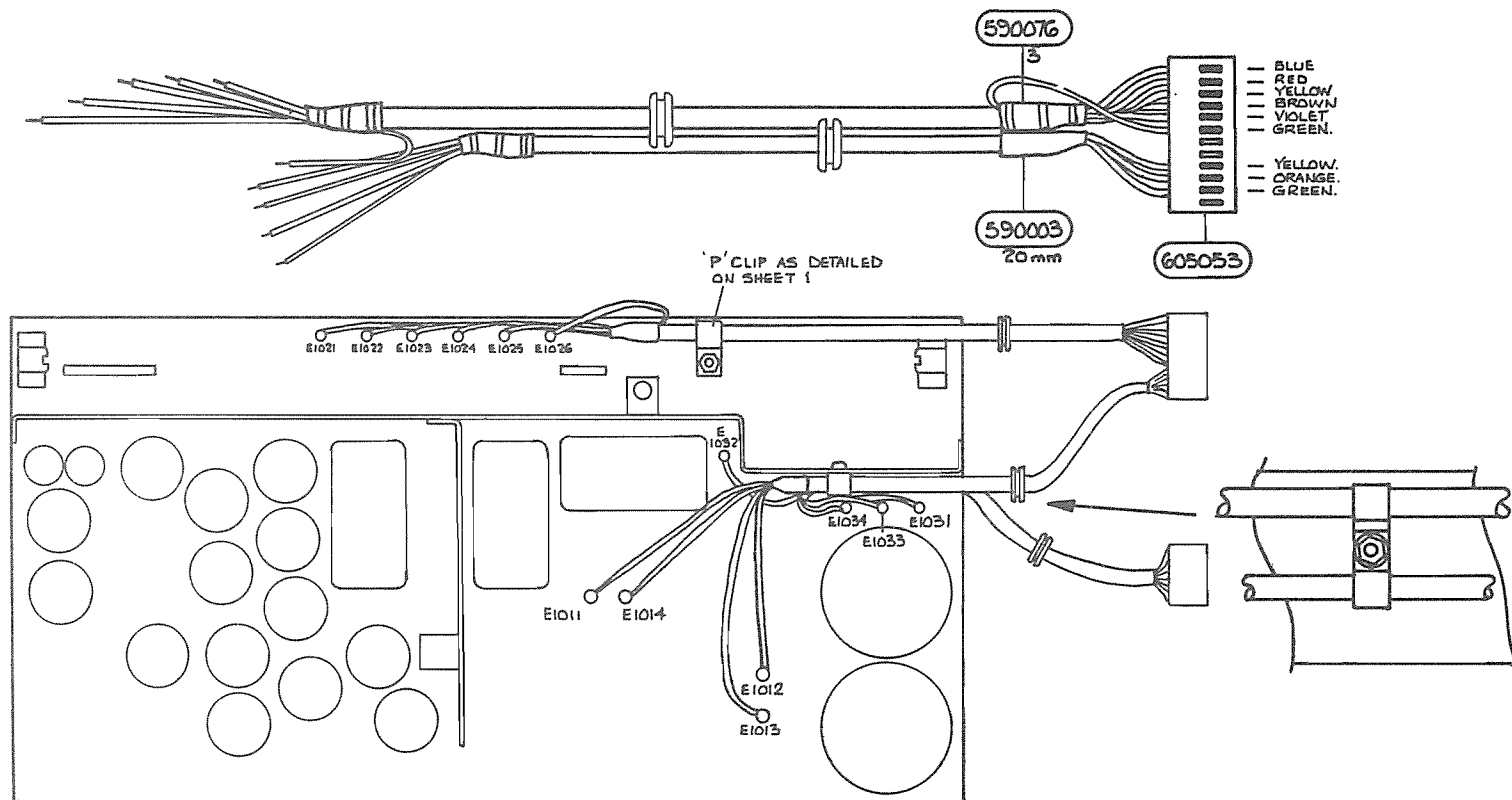

DESIG	PART NO	DESCRIPTION	PRINC MANUF	MANUF PART NUMBER	CLASS	UM	QUANTITY	CHANGES
R1	008081	RES WW 120R 5% 7W	YTM	KH210-9-120-5%		EA	1	
R3	007393	RES MO 39K 2% 2W	ELECTROSIL	FP2	-	EA	2	
R4	007393	RES MO 39K 2% 2W	ELECTROSIL	FP2	-	EA	-	
R5	000560	RES CF 56R 5% .25W	NECHM	CFR25	A	EA	2	
R6	000560	RES CF 56R 5% .25W	NECHM	CFR25	A	EA	-	
R7	000330	RES CF 33R 5% .25W	NECHM	CFR25	A	EA	2	
R8	000330	RES CF 33R 5% .25W	NECHM	CFR25	A	EA	-	
R9	000241	RES CF 240R 5% .25W	NECHM	CFR25	A	EA	1	
R10	000472	RES CF 4K7 5% .25W	NECHM	CFR25	A	EA	1	
R11	000104	RES CF 100K 5% .25W	NECHM	CFR25	A	EA	1	
R12	000150	RES CF 15R 5% .25W	NEOHM	CFR25	A	EA	4	
R13	000150	RES CF 15R 5% .25W	NEOHM	CFR25	A	EA	-	
R14	000150	RES CF 15R 5% .25W	NEOHM	CFR25	A	EA	-	
R15	000150	RES CF 15R 5% .25W	NEOHM	CFR25	A	EA	-	
R16	000151	RES CF 150R 5% .25W	NEOHM	CFR25	A	EA	2	
R17	000151	RES CF 150R 5% .25W	NEOHM	CFR25	A	EA	-	
R18	000105	RES CF 1M0 5% .25W	NEOHM	CFR25	A	EA	1	
C3	180066	CAP AE 680UF 200V	NIPPON	NMRH680/200		EA	2	
C4	180066	CAP AE 680UF 200V	NIPPON	NMRH680/200		EA	-	
C5	104024	CAP CD 10nF +80%-20% 100V	ITT	WPH5K210N02S		EA	6	
C6	104024	CAP CD 10nF +80%-20% 100V	ITT	WPH5K210N02S		EA	-	
C7	140040	CAP PP 10nF 5% 2KV	STEATITE	MKP1841	-	EA	2	
C8	140040	CAP PP 10nF 5% 2KV	STEATITE	MKP1841	-	EA	-	
C9	150022	CAP DT 2U2F 20% 35V	AVX	TAP2R2M35F	A	EA	1	
C10	104024	CAP CD 10nF +80%-20% 100V	ITT	WPH5K210N02S		EA	-	
C11	194024	CAP CD 10nF +80%-20% 100V	ITT	WPH5K210N02S		EA	-	
C12	104024	CAP CD 10nF +80%-20% 100V	ITT	WPH5K210N02S		EA	-	
C13	164024	CAP CD 10nF +80%-20% 100V	ITT	WPH5K210N02S		EA	-	
C14	180067	CAP AE 2200UF 16V	RUBICON	16PS2/2200		EA	14	
C15	180067	CAP AE 2200UF 16V	RUBICON	16PS2/2200		EA	-	
C16	180067	CAP AE 2200UF 16V	RUBICON	16PS2/2200		EA	-	
C17	180067	CAP AE 2200UF 16V	RUBICON	16PS2/2200		EA	-	
C18	180067	CAP AE 2200UF 16V	RUBICON	16PS2/2200		EA	-	
C19	180067	CAP AE 2200UF 16V	RUBICON	16PS2/2200		EA	-	
C20	180067	CAP AE 2200UF 16V	RUBICON	16PS2/2200		EA	-	
C21	180067	CAP AE 2200UF 16V	RUBICON	16PS2/2200		EA	-	
C22	180067	CAP AE 2200UF 16V	RUBICON	16PS2/2200		EA	-	
C23	180067	CAP AE 2200UF 16V	RUBICON	16PS2/2200		EA	-	
C24	180067	CAP AE 2200UF 16V	RUBICON	16PS2/2200		EA	-	
C25	180067	CAP AE 2200UF 16V	RUBICON	16PS2/2200		EA	-	
C26	180067	CAP AE 2200UF 16V	RUBICON	16PS2/2200		EA	-	
C27	180067	CAP AE 2200UF 16V	RUBICON	16PS2/2200		EA	-	
C30	100152	CAP CP 1n5F 10% 100V	PHILIPS	2222 630 19152	-	EA	2	
C31	100152	CAP CP 1n5F 10% 100V	PHILIPS	2222 630 19152	-	EA	-	
C32	102332	CAP CD 3n3F +40-20% 500V	BECK	CD08K303NXSCR/SK500D A	A	EA	3	

DESIG	PART NO	DESCRIPTION	PRINC MANUF	MANUF PART NUMBER	CLASS	UM	QUANTITY	CHANGES
C33	102332	CAP CD 3n3F +40-20% 500V	BECK	CD08K303NXSCR/SK500D A	A	EA	-	
C34	102332	CAP CD 3n3F +40-20% 500V	BECK	CD08K303NXSCR/SK500D A	A	EA	-	
C35	140017	CAP PP 150NF 10% 250V	TELEFUNKEN	9982		EA	2	
C36	140017	CAP PP 150NF 10% 250V	TELEFUNKEN	9982		EA	-	
C37	140089	CAP SUPP 2n2F 250V	WIMA	MP3-Y		EA	3	
C38	140089	CAP SUPP 2n2F 250V	WIMA	MP3-Y		EA	-	
C39	180041	CAP AE 100UF 40V	STEATITE	EKM 00FD 310G		EA	2	
C40	180041	CAP AE 100UF 40V	STEATITE	EKM 00FD 310G		EA	-	
C41	104055	CAP CER MULTILAYER 3u3F 50V	SPRAUGE	3C20Z5U335M050B		EA	4	
C42	104055	CAP CER MULTILAYER 3u3F 50V	SPRAUGE	3C20Z5U335M050B		EA	-	
C43	104055	CAP CER MULTILAYER 3u3F 50V	SPRAUGE	3C20Z5U335M050B		EA	-	
C44	104055	CAP CER MULTILAYER 3u3F 50V	SPRAUGE	3C20Z5U335M050B		EA	-	
C45	110053	CAP PE 47NF 10% 630V	WIMA	MKS4		EA	1	
C46	140089	CAP SUPP 2n2F 250V	WIMA	MP3-Y		EA	-	
D1	209015	DIODE BR 4A 800V	INT RECTIFIERS	KBU4K		EA	1	
D5	200001	DIODE GP 75mA 75V	FAIRCHILD	1N4148		EA	3	
D7	200030	DIODE LP 3A/600V RECT	PHILIPS	BYW95C		EA	2	
D8	200030	DIODE LP 3A/600V RECT	PHILIPS	BYW95C		EA	-	
D9	200001	DIODE GP 75mA 75V	FAIRCHILD	1N4148		EA	-	
D10	200001	DIODE GP 75mA 75V	FAIRCHILD	1N4148		EA	-	
D11	200031	16A/45V SCHOTT RECT	UNITRODE	USD945		EA	4	
D12	200031	16A/45V SCHOTT RECT	UNITRODE	USD945		EA	-	
D13	200031	16A/45V SCHOTT RECT	UNITRODE	USD945		EA	-	
D14	200031	16A/45V SCHOTT RECT	UNITRODE	USD945		EA	-	
Q1	230099	TRAN MOSFET N CHAN 500V	IXYS	IXTH12N50		EA	2	
Q2	230099	TRAN MOSFET N CHAN 500V	IXYS	IXTH12N50		EA	-	
T1	350002-1	GATE DRIVE Tx ASSY	DATRON	SEE DRG		EA	2	
T2	350002-1	GATE DRIVE Tx ASSY	DATRON	SEE DRG		EA	-	
T3	350003-1	CURRENT TX	DATRON	SEE DRG		EA	1	
T4	300032-1	POWER Tx PRIMARY	DATRON	SEE DRG		EA	1	
T5	300033-1	POWER Tx SECONDARY	DATRON	SEE DRG		EA	1	
RL3	330054	RELAY 1PNO POWER MONOSTABLE	SDS	DK1a-5V		EA	1	
L1	370037-1	CHOKE CM	DATRON	SEE DRG		EA	1	
L2	370038-1	CHOKE OUTPUT (POWER IND)	DATRON	SEE DRG		EA	2	
L3	370038-1	CHOKE OUTPUT (POWER IND)	DATRON	SEE DRG		EA	-	
W101	540027	WRIE 2.65 DIA POLYESTER CU	HI-WIRE LTD	G2		AR	1	
J1	604091	PLUG PCB 10WAY VERT	HARWIN	M20-9991005		EA	1	
J3	620003	SOLDER PIN	HARWIN	H2105A01		EA	2	
J14	620003	SOLDER PIN	HARWIN	H2105A01		EA	-	
J28	604090	PLUG PCB 5WAY VERT	HARWIN	M20-9990505		EA	1	
E241	612004-1	STANDOFF M3 X 4	DATRON	SEE DRAWING		EA	9	
E242	612004-1	STANDOFF M3 X 4	DATRON	SEE DRAWING		EA	-	
E243	612004-1	STANDOFF M3 X 4	DATRON	SEE DRAWING		EA	-	
E1011	620006	SOLDER TURRET	HARWIN	H9001-01		EA	14	
E1012	620006	SOLDER TURRET	HARWIN	H9001-01		EA	-	

DESIG	PART NO	DESCRIPTION	PRINC MANUF	MANUF PART NUMBER	CLASS	UM	QUANTITY	CHANGES
E1013	620006	SOLDER TURRET	HARWIN	H9001-01	EA	-		
E1014	620006	SOLDER TURRET	HARWIN	H9001-01	EA	-		
E1021	620006	SOLDER TURRET	HARWIN	H9001-01	EA	-		
E1022	620006	SOLDER TURRET	HARWIN	H9001-01	EA	-		
E1023	620006	SOLDER TURRET	HARWIN	H9001-01	EA	-		
E1024	620006	SOLDER TURRET	HARWIN	H9001-01	EA	-		
E1025	620006	SOLDER TURRET	HARWIN	H9001-01	EA	-		
E1026	620006	SOLDER TURRET	HARWIN	H9001-01	EA	-		
E1031	620006	SOLDER TURRET	HARWIN	H9001-01	EA	-		
E1032	620006	SOLDER TURRET	HARWIN	H9001-01	EA	-		
E1033	620006	SOLDER TURRET	HARWIN	H9001-01	EA	-		
E1034	620006	SOLDER TURRET	HARWIN	H9001-01	EA	-		
TP1	620007	TEST POINT TERMINAL	MICROVAR	TYPE C30	EA	4		
TP2	620007	TEST POINT TERMINAL	MICROVAR	TYPE C30	EA	-		
TP3	620007	TEST POINT TERMINAL	MICROVAR	TYPE C30	EA	-		
TP4	620007	TEST POINT TERMINAL	MICROVAR	TYPE C30	EA	-		
F1	920025	FUSE 2A 20MM QUICK BLOW	BELLING LEE	L1427B	EA	1		
F2	920191	FUSE THERMAL 147 DEG C	UMI	X150	EA	1		
	400791-1	ASSY PCB SMPS CONTROL 4600	DATRON	SEE DRG	EA	1		
	410411-1	PCB SMPS MAIN		SEE DRAWING	EA	1		
450639-1		INSULATION PAD	SEE DRG		A	EA	1	
450650-1		CONTROL SCREEN SMPS		SEE DRG	EA	1		
450651-1		TX SCREEN SMPS		SEE DRG	EA	1		
450686-1		HEATSINK SUPPORT BLOCK SMPS		SEE DRG	EA	1		
512000		WIRE 7/.2 PTFE 1KV BLK	BSG210	TYPE C	AR	1		
512222		WIRE 7/.2 PTFE 1KV RED	BSG210	TYPE C	AR	1		
512444		WIRE 7/.2 PTFE 1KV YEL	BSG210	TYPE C	AR	1		
512555		WIRE 7/.2 PTFE 1KV GRN	BSG210	TYPE C	AR	1		
512666		WIRE 7/.2 PTFE 1KV BLU	BSG210	TYPE C	AR	1		
512999		WIRE 7/.2 PTFE 1KV WHI	BSG210	TYPE C	AR	1		
560008-3		CABLE 4-CORE 7/.2 PTFE SC		SEE DRG	MM	460		
560009		CABLE 8 CORE 7/0.2 PVC SC			MM	535		
590003		SLEEVE HS. 6.4mm YLW.	R.S.COMONENTS	399-524	AR	1		
590004		SLEEVE PTFE 1mm BLK	HELLERMAN	FE10	AR	1		
590032		SLEEVE HS. 4.8mm YLW	R.S.COMONENTS	399-518	AR	1		
590063		TY-WRAP	PANDUIT	PI.T31	EA	1		
590076		SOLDER SLEEVE DIAM.7.3	RAYFAST	CWT-7	EA	3		
590078		SLEEVE HS 12.7 H.T.	RS	398-408	AR	1		
605052		SOCKET PCB 8-WAY .1"	MOLEX	22-01-2085	EA	1		
605053		12 WAY SOCKET	MOLEX		EA	1		
605057		CRIMP TERMINAL GD PL	MOLEX	4809-GL	EA	13		
611004		SCREW M3 X 6 POZIPAN SZP			EA	3		
611012		SCREW M3 X 12 POZICSK SZP			EA	2		
611015		SCREW M3 X 8 POZICSK SZP			EA	4		
611016		SCREW M3 X 8 POZIPAN SZP			EA	5		

DESIG	PART NO	DESCRIPTION	PRINC MANUF	MANUF PART NUMBER	CLASS	UM	QUANTITY	CHANGES
612004-1		STANDOFF M3 X 4	DATRON	SEE DRAWING	EA	-		
613005		WASHER M3 INT SHAKEPROOF			EA	6		
613029		WASHER M3 WAVY SS			EA	7		
615002		NUT M3 FULL SZP			EA	8		
618001		BUSH INSUL. TO220	PHILIPS	56359C	EA	4		
630003		CLIP P' 4.8	SES	CN5	EA	2		
630004		CLIP P' 6.4	SES	CN6	EA	1		
630018		GROMMET 4.0 DIA.	R S COMPONENTS	543-197	EA	2		
630024		BEAD CERAMIC 16 SWG	PARK ROYAL PORCELAIN	No2	EA	12		
630029		TAPE 1/4" X 1/32" DBL.SIDED	3M	4032	AR	1		
630285		PCB GUIDE PCB MOUNT	RICHO	CVGMIN-1	EA	2		
630310		GROMMET 6.5 DIA	R S COMPONENTS	543-204	EA	1		
630313		LABEL DANGER HIGH VOLTAGE			EA	2		
920126		FUSE HOLDER PCB 20MM	BELLING LEE	11426	EA	1		
920207		RESISTER MTG BRACKET	VTM	18141	EA	1		

Encl

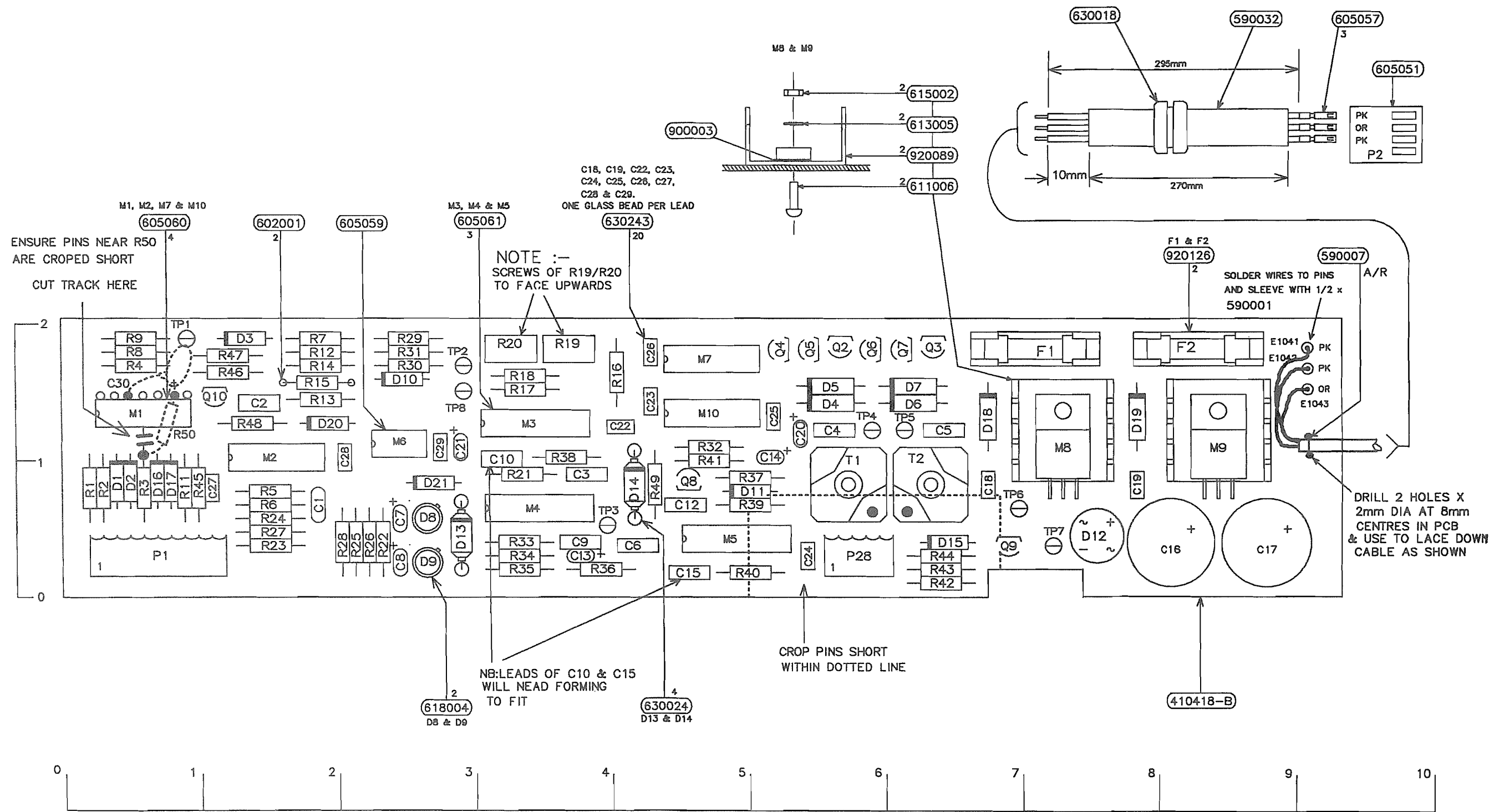

DESIG	PART NO	DESCRIPTION	PRINC MANUF	MANUF PART NUMBER	CLASS	UM	QUANTITY	CHANGES
R1	011001	RES MF 1K00 1% .12W 50PPM	HOLSWORTHY	H8C	A	EA	4	
R2	011001	RES MF 1K00 1% .12W 50PPM	HOLSWORTHY	H8C	A	EA	-	
R3	000472	RES CF 4K7 5% .25W	NEOHM	CFR25	A	EA	8	
R4	000474	RES CF 470K 5% .25W	NEOHM	CFR25	A	EA	3	
R5	000102	RES CF 1K0 5% .25W	NEOHM	CFR25	A	EA	2	
R6	000513	RES CF 51K 5% .25W	NEOHM	CFR25	A	EA	1	
R7	000472	RES CF 4K7 5% .25W	NEOHM	CFR25	A	EA	-	
R8	012211	RES MF 2K21 1% .12W 50PPM	HOLSWORTHY	H8C	A	EA	1	
R9	014751	RES MF 4K75 1% .12W 50PPM	HOLSWORTHY	H8C	A	EA	1	
R11	000225	RES CF 2M2 5% .25W	NEOHM	CFR25	A	EA	1	
R12	011001	RES MF 1K00 1% .12W 50PPM	HOLSWORTHY	H8C	A	EA	-	
R13	013011	RES MF 3K01 1% .12W 50PPM	HOLSWORTHY	H8C	A	EA	1	
R14	014991	RES MF 4K99 1% .12W 50PPM	HOLSWORTHY	H8C	A	EA	1	
R15	00000F	RES FSV						
R16	000103	RES CF 10K 5% .25W	NEOHM	CFR25	A	EA	8	
R17	000473	RES CF 47K 5% .25W	NEOHM	CFR25	A	EA	1	
R18	000102	RES CF 1K0 5% .25W	NEOHM	CFR25	A	EA	-	
R19	066103	RES CF 10K VERT S/T	BECKMAN	72XW	A	EA	1	
R20	066502	RES CF 5K VERT S/T	BECKMAN	72XW	A	EA	1	
R21	011001	RES MF 1K00 1% .12W 50PPM	HOLSWORTHY	H8C	A	EA	-	
R22	000472	RES CF 4K7 5% .25W	NEOHM	CFR25	A	EA	-	
R23	012371	RES MF 2K37 1% .12W 50PPM	HOLSWORTHY	H8C	A	EA	2	
R24	011431	RES MF 1K43 1% .12W 50PPM	HOLSWORTHY	H8C	A	EA	2	
R25	000474	RES CF 470K 5% .25W	NEOHM	CFR25	A	EA	-	
R26	000472	RES CF 4K7 5% .25W	NEOHM	CFR25	A	EA	-	
R27	012371	RES MF 2K37 1% .12W 50PPM	HOLSWORTHY	H8C	A	EA	-	
R28	011431	RES MF 1K43 1% .12W 50PPM	HOLSWORTHY	H8C	A	EA	-	
R29	000472	RES CF 4K7 5% .25W	NEOHM	CFR25	A	EA	-	
R30	000821	RES CF 820R 5% .25W	NEOHM	CFR25	A	EA	1	
R31	000474	RES CF 470K 5% .25W	NEOHM	CFR25	A	EA	-	
R32	011002	RES MF 1K00 1% .12W 50PPM	HOLSWORTHY	H8C	A	EA	2	
R33	000472	RES CF 4K7 5% .25W	NEOHM	CFR25	A	EA	-	
R34	000103	RES CF 10K 5% .25W	NEOHM	CFR25	A	EA	-	
R35	000101	RES CF 100R 5% .25W	NEOHM	CFR25	A	EA	1	
R35	000103	RES CF 10K 5% .25W	NEOHM	CFR25	A	EA	-	
R37	000103	RES CF 10K 5% .25W	NEOHM	CFR25	A	EA	-	
R38	041004	RES MF 1M00 1% .12W 50PPM	HOLSWORTHY	H8C	A	EA	1	
R39	000103	RES CF 10K 5% .25W	NEOHM	CFR25	A	EA	-	
R40	000434	RES CF 430K 5% .25W	NEOHM	CFR25	A	EA	1	
R41	000184	RES CF 180K 5% .25W	NEOHM	CFR25	A	EA	1	
R42	000472	RES CF 4K7 5% .25W	NEOHM	CFR25	A	EA	-	
R43	000103	RES CF 10K 5% .25W	NEOHM	CFR25	A	EA	-	
R44	000103	RES CF 10K 5% .25W	NEOHM	CFR25	A	EA	-	
R45	000103	RES CF 10K 5% .25W	NEOHM	CFR25	A	EA	-	
R46	000223	RES CF 22K 5% .25W	NEOHM	CFR25	A	EA	1	

DESIG	PART NO	DESCRIPTION	PRINC MANUF	MANUF PART NUMBER	CLASS	UM	QUANTITY	CHANGES
R47	000222	RES CF 2K2 5% .25W	NEOHM	CFR25	A	EA	1	
R48	000472	RES CF 4K7 5% .25W	NEOHM	CFR25	A	EA	-	
R49	011002	RES MF 10K0 1% .12W 50PPM	HOLSWORTHY	H8C	A	EA	-	
R50	000224	RES CF 220K 5% .25W	NEOHM	CFR25	A	EA	1	
C1	100331	CAP CP 330PF 2% 100V	PHILIPS	2222 683 58331				
C2	110042	CAP PE 100NF 20% 63V	WIMA	MKS2				
C3	120040	CAP PC 1n5F 5% 100V	WIMA	FKC2	A	EA	1	
C4	110042	CAP PE 100NF 20% 63V	WIMA	MKS2				
C5	110042	CAP PE 100NF 20% 63V	WIMA	MKS2				
C6	100152	CAP CP 1n5F 10% 100V	PHILIPS	2222 630 19152				
C7	150006	CAP DT 4U7F 200% 16V	AVX	TAP4R7M16F	A	EA	2	
C8	150006	CAP DT 4U7F 200% 16V	AVX	TAP4R7M16F	A	EA	-	
C9	110020	CAP PE 47NF 20% 63V	WIMA	MKS2				
C10	110039	CAP PE 470NF 20% 63V	WIMA	MKS2				
C12	110042	CAP PE 100NF 20% 63V	WIMA	MKS2				
C13	110030	CAP PE 1NF 20% 100V	WIMA	FKS2				
C14	150015	CAP DT 10UF 20% 35V	AVX	TAP10M35F	A	EA	3	
C15	120017	CAP PC 10nF 20% 100V	WIMA	FKC2				
C16	180047	CAP AE 1000UF 40V	ECC	SHVB				
C17	180047	CAP AE 1000UF 40V	ECC	SHVB				
C18	104026	CAP CD 47NF +50%-20% 50V	SIEMENS	B37449				
C19	104026	CAP CD 47NF +50%-20% 50V	SIEMENS	B37449				
C20	150015	CAP DT 10UF 20% 35V	AVX	TAP10M35F	A	EA	-	
C21	150015	CAP DT 10UF 20% 35V	AVX	TAP10M35F	A	EA	-	
C22	104026	CAP CD 47NF +50%-20% 50V	SIEMENS	B37449				
C23	104026	CAP CD 47NF +50%-20% 50V	SIEMENS	B37449				
C24	104026	CAP CD 47NF +50%-20% 50V	SIEMENS	B37449				
C25	104026	CAP CD 47NF +50%-20% 50V	SIEMENS	B37449				
C26	104C26	CAP CD 47NF +50%-20% 50V	SIEMENS	B37449				
C27	104026	CAP CD 47NF +50%-20% 50V	SIEMENS	B37449				
C28	104026	CAP CD 47NF +50%-20% 50V	SIEMENS	B37449				
C29	104026	CAP CD 47NF +50%-20% 50V	SIEMENS	B37449				
C30	150020	CAP DT 10UF 20% 25V	AVX	TAP10M25F	A	EA	1	
D1	200001	DIODE GP 75mA 75V	FAIRCHILD	1N4148				
D2	200001	DIODE GP 75mA 75V	FAIRCHILD	1N4148				
D3	200001	DIODE GP 75mA 75V	FAIRCHILD	1N4148				
D4	200002	DIODE GP 1A 50V	FAIRCHILD	1N4001				
D5	200002	DIODE GP 1A 50V	FAIRCHILD	1N4001				
D6	200002	DIODE GP 1A 50V	FAIRCHILD	1N4001				
D7	200002	DIODE GP 1A 50V	FAIRCHILD	1N4001				
D8	214012	DIODE ZN 2V45 20PPM	FERRANTI	ZN458				
D9	214012	DIODE ZN 2V45 20PPM	FERRANTI	ZN458				
D10	200001	DIODE GP 75mA 75V	FAIRCHILD	1N4148				
D11	220010	DIODE GP SB	H.P.	1N5711	A	EA	1	
D12	209003	DIODE BR 1A5 100V	MICRO-ELECTRONICS	W001				

DESIG	PART NO	DESCRIPTION	PRINC MANUF	MANUF PART NUMBER	CLASS	UM	QUANTITY	CHANGES
D13	213009	DIODE ZN 15V 5W	UNITRODE	TV5515		EA	2	
D14	213009	DIODE ZN 15V 5W	UNITRODE	TV5515		EA	-	
D15	210240	DIODE ZN 24V 400mW	PHILIPS	BZX79C24	A	EA	1	
D16	200001	DIODE GP 75mA 75V	FAIRCHILD	1N4148		EA	-	
D17	200001	DIODE GP 75mA 75V	FAIRCHILD	1N4148		EA	-	
D18	200002	DIODE GP 1A 50V	FAIRCHILD	1N4001		EA	-	
D19	200002	DIODE GP 1A 50V	FAIRCHILD	1N4001		EA	-	
D20	200001	DIODE GP 75mA 75V	FAIRCHILD	1N4148		EA	-	
D21	210200	DIODE ZN 20V 400mW	PHILIPS	BZX79C20	A	EA	1	
Q2	230103	TRAN MOSFET N CHAN 60V/2.0A	SUPERTEX	TN0106N3		EA	2	
Q3	230103	TRAN MOSFET N CHAN 60V/2.0A	SUPERTEX	TN0106N3		EA	-	
Q4	240014	TRAN NPN TO92	NATIONAL	BC337		EA	2	
Q5	250011	TRAN PNP TO92	NATIONAL	BC327		EA	2	
Q6	240014	TRAN NPN TO92	NATIONAL	BC337		EA	-	
Q7	250011	TRAN PNP TO92	NATIONAL	BC327		EA	-	
Q8	230078	TRAN MOSFET N CHAN	SILICONIX	BS170		EA	1	
Q9	240006	TRAN NPN TO92	MOTOROLA	2N3904		EA	2	
Q10	240006	TRAN NPN TO92	MOTOROLA	2N3904		EA	-	
M1	260039	IC LIN OP AMP QUAD	NATIONAL	LM324N		EA	2	
M2	260039	IC LIN OP AMP QUAD	NATIONAL	LM324N		EA	-	
M3	280145	IC DIG	MOTOROLA	MC14046B		EA	1	
M4	280178	IC DIG MONO DUAL	PHILIPS	HEF4528B		EA	2	
M5	280178	IC DIG MONO DUAL	PHILIPS	HEF4528B		EA	-	
M6	260075	IC LIN V COMP DUAL	NATIONAL	LM2903N		EA	1	
M7	280085	IC DIG QUAD 2 I/P AND	MOTOROLA	MC14081BCP		EA	1	
M8	260006	IC DIG REG 15V 1A	MOTOROLA	MC7815CT		EA	1	
M9	260051	IC DIG REG -15V 1A	MOTOROLA	MC7915CT		EA	1	
M10	280011	IC DIG FLIP/FLOP D.DUAL	MOTOROLA	MC14013BCP		EA	1	
T1	350002-1	GATE DRIVE Tx ASSY	DATRON	SEE DRG		EA	2	
T2	350002-1	GATE DRIVE Tx ASSY	DATRON	SEE DRG		EA	-	
P1	605171	SOCKET PCB HORIZ 10WAY	HARWIN	M20-989 10 05		EA	1	
P28	605170	SOCKET PCB HORIZ 5 WAY	HARWIN	M20-989 05 05		EA	1	
E1041	620009	PIN VERO 1.0MM SS	R S COMPONENTS	433-854		EA	3	
E1042	620009	PIN VERO 1.0MM SS	R S COMPONENTS	433-854		EA	-	
E1043	620009	PIN VERO 1.0MM SS	R S COMPONENTS	433-854		EA	-	
TP1	620007	TEST POINT TERMINAL	MICROVAR	TYPE C30		EA	8	
TP2	620007	TEST POINT TERMINAL	MICROVAR	TYPE C30		EA	-	
TP3	620007	TEST POINT TERMINAL	MICROVAR	TYPE C30		EA	-	
TP4	620007	TEST POINT TERMINAL	MICROVAR	TYPE C30		EA	-	
TP5	620007	TEST POINT TERMINAL	MICROVAR	TYPE C30		EA	-	
TP6	620007	TEST POINT TERMINAL	MICROVAR	TYPE C30		EA	-	
TP7	620007	TEST POINT TERMINAL	MICROVAR	TYPE C30		EA	-	
TP8	620007	TEST POINT TERMINAL	MICROVAR	TYPE C30		EA	-	
F1	920084	FUSE 500mA 250V 20mm SLOW BLOW	BELLING LEE	L2080A/.500		EA	2	
F2	920084	FUSE 500mA 250V 20mm SLOW BLOW	BELLING LEE	L2080A/.500		EA	-	

DESIG	PART NO	DESCRIPTION	PRINC MANUF	MANUF PART NUMBER	CLASS	UM	QUANTITY	CHANGES
	410418-B	PCB SMPS CONTROL		SEE DRG			1	
	512333	WIRE 7/.2 PTFE 1KV ORANGE	BSG210	TYPE C		AR	1	
	513001	WIRE 7/.2 PTFE 1KV PINK	BSG210	TYPE C		AR	1	
	590001	SLEEVE NP 1.5 X 20MM BLK	HEILERMANN	H15		EA	2	
	590007	LACING TAPE 2.5MM	ALPHA	LC136	A	AR	1	
	590032	SLEEVE HS. 4.8mm YLW	R.S.COMPONENTS	399-518		AR	1	
	602001	TERMINAL PSY	MOLEX	02-04-5114		EA	2	
	605051	HOUSING 4WAY	MOLEX	6471 SERIES 22-01-20		EA	1	
	605057	CRIMP TERMINAL GD PL	MOLEX	4809-GL		EA	3	
	605059	SOCKET PCB 8-WAY DIL	JERMYN	J23-18008	A	EA	1	
	605060	SOCKET PCB 14-WAY DIL	JERMYN	J23-18014	A	EA	4	
	605061	SOCKET PCB 16-WAY DIL	JERMYN	J23-18016	A	EA	3	
	611006	SCREW M3 X 10 POZIPAN SZP				EA	2	
	613005	WASHER M3 INT SHAKEPROOF				EA	2	
	615002	NUT M3 FULL SZP				EA	2	
	618004	PAD MNTG. TO18	JERMYN	TO18-008D		EA	2	
	630018	GROMMET 4.0 DIA.	R S COMPONENTS	543-197		EA	1	
	630024	BEAD CERAMIC 16 SWG	PARK ROYAL PORCELAIN	No2		EA	4	
	630243	BEAD GLASS 2.4 X 0.81 X 1.8	MANSOI, (PREFORMS) LT	M5363B/3		EA	20	
	900003	HEATSHRINK COMPOUND	RS	554-311		AR	1	
	920089	HEATSINK TO220	THERMALLOY	6073B		EA	2	
	920126	FUSE HOLDER PCB 20MM	BELLING LEE	L1426		EA	2	

End

DRILL HOLE 0.8mm DIA
WHERE INDICATED AT
"A". (SOLDER SIDE OF
PCB SHOWN)
FIT WIRE LINK (540001)
BETWEEN "A" AND PAD
"B" AFTER FITTING RL101

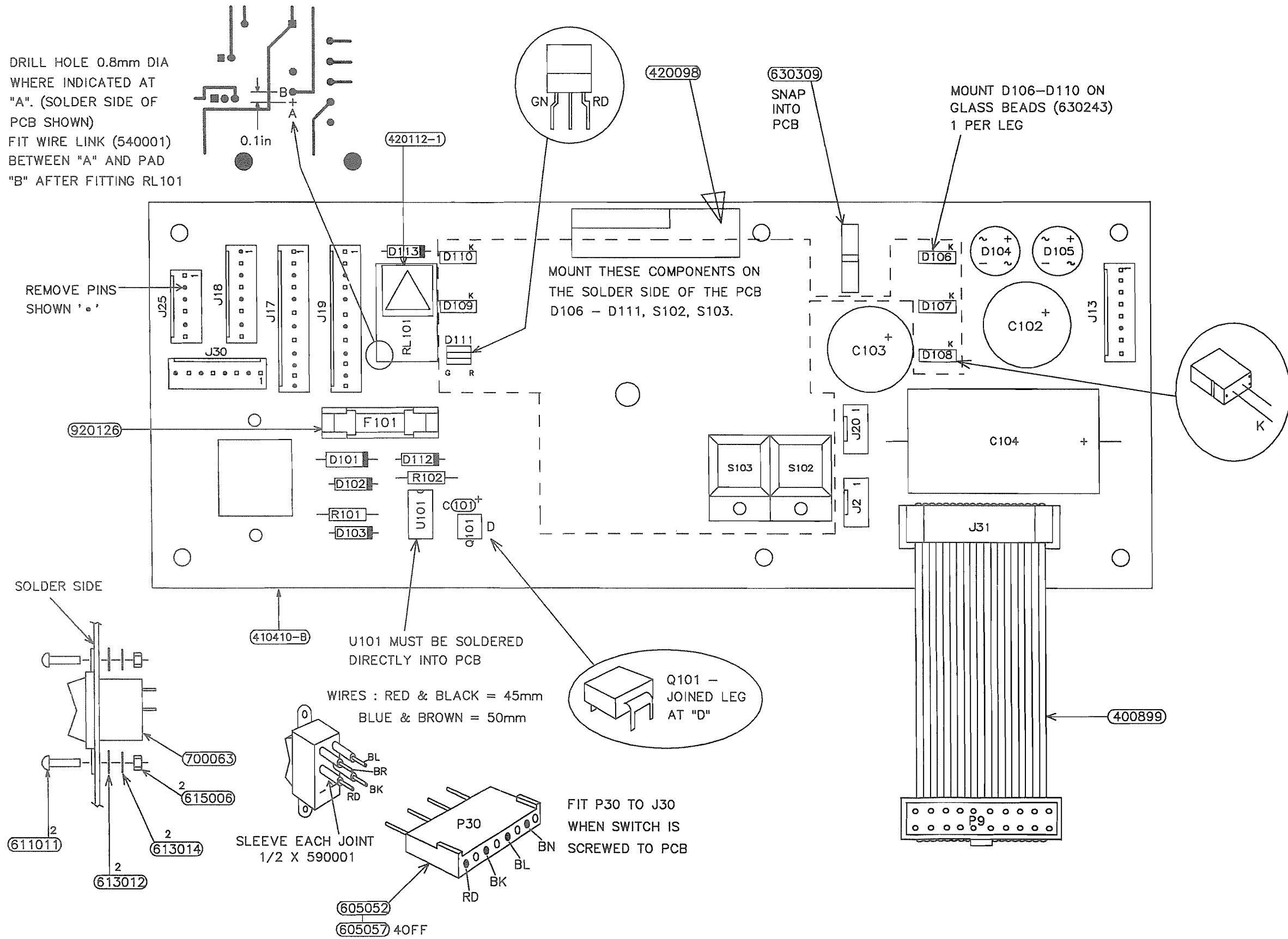

DESIG	PART NO	DESCRIPTION	PRINC MANUF	MANUF PART NUMBER	CLASS	UM	QUANTITY	CHANGES
R101	015622	RES MF 56K2 1% .12W 50PPM	HOLSWORTHY	HBC	A	EA	1	
R102	041004	RES MF 1M00 1% .12W 50PPM	HOLSWORTHY	HBC	A	EA	1	
C101	150016	CAP DT 10F 20% 35V	AVX	TAP1R0M35F	A	EA	1	
C102	180027	CAP AE 2200UF 40V	STC	SMVB 2200UF/40V		EA	2	
C103	180027	CAP AE 2200UF 40V	STC	SMVB 2200UF/40V		EA	-	
C104	180004	CAP AE 4700UF 16V	STEATITE	EG4700/16		EA	1	
D101	200006	DIODE ZN 1A 600V	FAIRCHILD	1N4005		EA	1	
D102	213019	DIODE ZN 200V 500mW	THOMPSON	BZ55C200	A	EA	1	
D103	200001	DIODE GP 75mA 75V	FAIRCHILD	1N4148		EA	3	
D104	209003	DIODE BR 1A5 100V	MICRO-ELECTRONICS	W001		EA	2	
D105	209003	DIODE BR 1A5 100V	MICRO-ELECTRONICS	W001		EA	-	
D106	220045	DIODE LE RED RECT	GI	MV57124		EA	5	
D107	220045	DIODE LE RED RECT	GI	MV57124		EA	-	
D108	220045	DIODE LE RED RECT	GI	MV57124		EA	-	
D109	220045	DIODE LE RED RECT	GI	MV57124		EA	-	
D110	220045	DIODE LE RED RECT	GI	MV57124		EA	-	
D111	220046	DIODE LE BICOLOUR R/G	III-V	TLMP5801		EA	1	
D112	200001	DIODE GP 75mA 75V	FAIRCHILD	1N4148		EA	-	
D113	200001	DIODE GP 75mA 75V	FAIRCHILD	1N4148		EA	-	
Q101	230109	TRAN MOSFET N CHAN 60V 0.8A	IR	IRFD113		EA	1	
U101	220038	OPTO ISOL 3KV	H.P.	6N133		EA	1	
RL101	330054	RELAY IPNO POWER MONOSTABLE	SDS	DK1a-5V		EA	1	
J2	604033	PLUG PCB 4-WAY .1"	MOLEX	22-29-2041		EA	2	
J13	604087	PLUG PCB 8 WAY .1"	MOLEX	22-29-2081		EA	3	
J17	604086	PLUG PCB 12-WAY .1"	MOLEX	22-29-2121		EA	2	
J18	604087	PLUG PCB 8 WAY .1"	MOLEX	22-29-2081		EA	-	
J19	604086	PLUG PCB 12-WAY .1"	MOLEX	22-29-2121		EA	-	
J20	604033	PLUG PCB 4-WAY .1"	MOLEX	22-29-2041		EA	-	
J25	604075	PLUG PCB 6-WAY .1"	MOLEX	22-29-2061		EA	1	
J30	604087	PLUG PCB 8 WAY .1"	MOLEX	22-29-2081		EA	-	
J31	400899-1	ASSY RIBBON CABLE 4600	DATRON	SEE DRG		EA	1	
S102	700061	SWITCH 1P C/O	SCHADOW	SRL BLACK/RED		EA	2	
S103	700061	SWITCH 1P C/O	SCHADOW	SRL BLACK/RED		EA	-	
F101	920084	FUSE 500mA 250V 20mm SLOW BLOW	BELLING LEE	L2080A/.500		EA	1	
	410410-B	PCB FRONT		SEE DRG		EA	1	
	420098	LABEL SERIAL/ASSY No.	RS	554-793		EA	1	
	420112-1	LABEL SSD WARNING 12 X 12mm		SEE DRG	A	EA	1	
	512000	WIRE 7/.2 PTFE 1KV BLK	BSG210	TYPE C		AR	1	
	512111	WIRE 7/.2 PTFE 1KV BRN	BSG210	TYPE C		AR	1	
	512222	WIRE 7/.2 PTFE 1KV RED	BSG210	TYPE C		AR	1	
	512666	WIRE 7/.2 PTFE 1KV BLU	BSG210	TYPE C		AR	1	
	590001	SLEEVE NP 1.5 X 20MM BLK	HELLERMANN	H15		EA	2	
	605052	HOUSING 8 WAY .1"	MOLEX	6471 SERIES 22-01-20		EA	1	
	605057	CRIMP TERMINAL GD PL	MOLEX	08-56-0120		EA	4	
	611011	SCREW M2.5 X 6 POZIPAN SZP				EA	2	

DATRON INSTRUMENTS LTD PARTS LIST 16-Mar-89 DESC: ASSY PCB FRONT 4600 DRG NO: LP400792-1 REV: 2 PAGE NO: 2

DESIG	PART NO	DESCRIPTION	PRINC MANUF	MANUF PART NUMBER	CLASS	UM	QUANTITY	CHANGES
	613012	WASHER M2.5 SZP				EA	2	
	613014	WASHER M2.5 INT. SHAKP.				EA	2	
	615006	NUT M2.5 FULL SZP				EA	2	
	630243	BEAD GLASS 2.4 X 0.81 X 1.8	MANSOL (PREFORMS) LT	M5363B/3		EA	10	
	630309	WIRE SADDLE PCB MOUNT	RICHO	WS-A-2-01		EA	1	
	700063	SWITCH 2P 2POSN ROCKER	PLESSEY	408/1/38521/110	A	EA	1	
	920126	FUSE HOLDER PCB 20MM	BELLING LEE	L1426		EA	1	

End



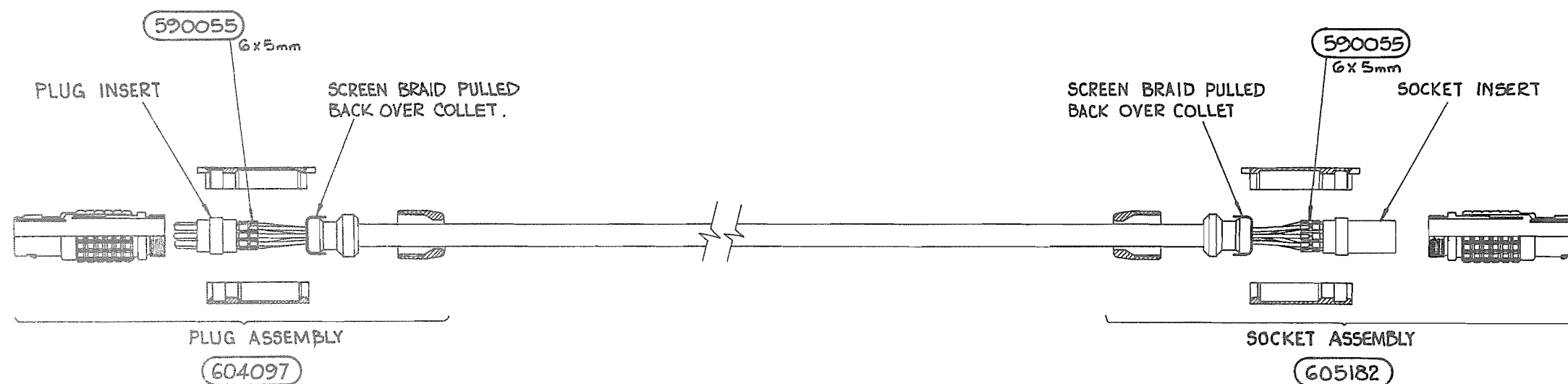
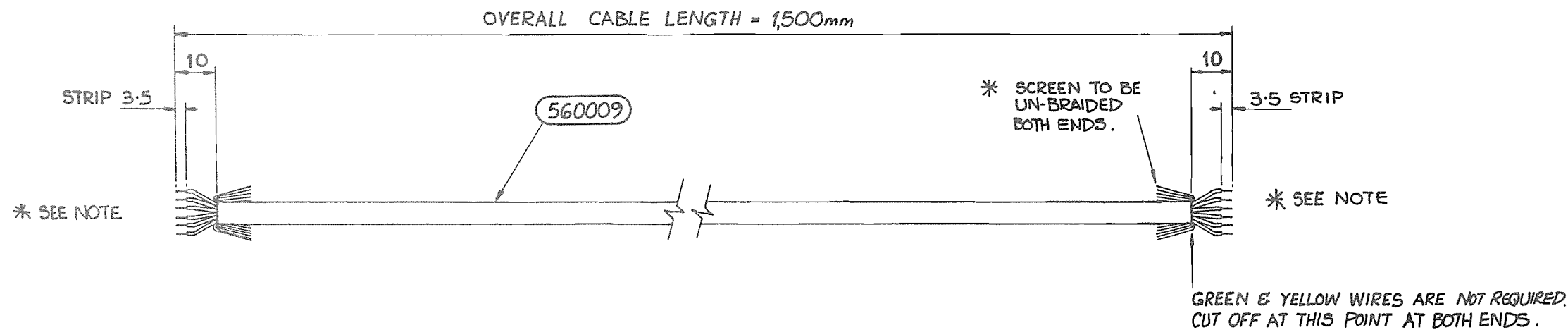

* NOTE
ENSURE COLLET & COLLET NUT ARE FITTED TO CABLE BEFORE STRIPPING OUTER SHEATH.

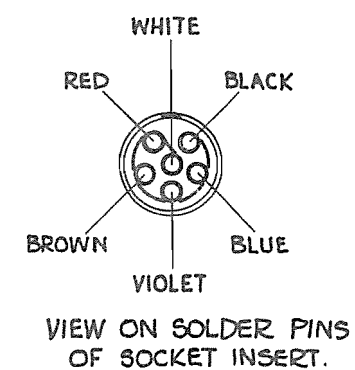
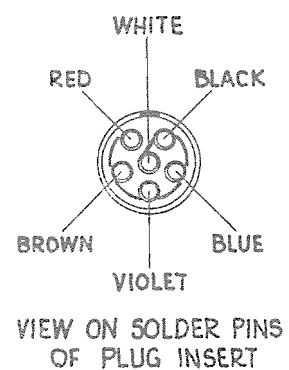

OVERALL CABLE LENGTH APPROX 1.5m

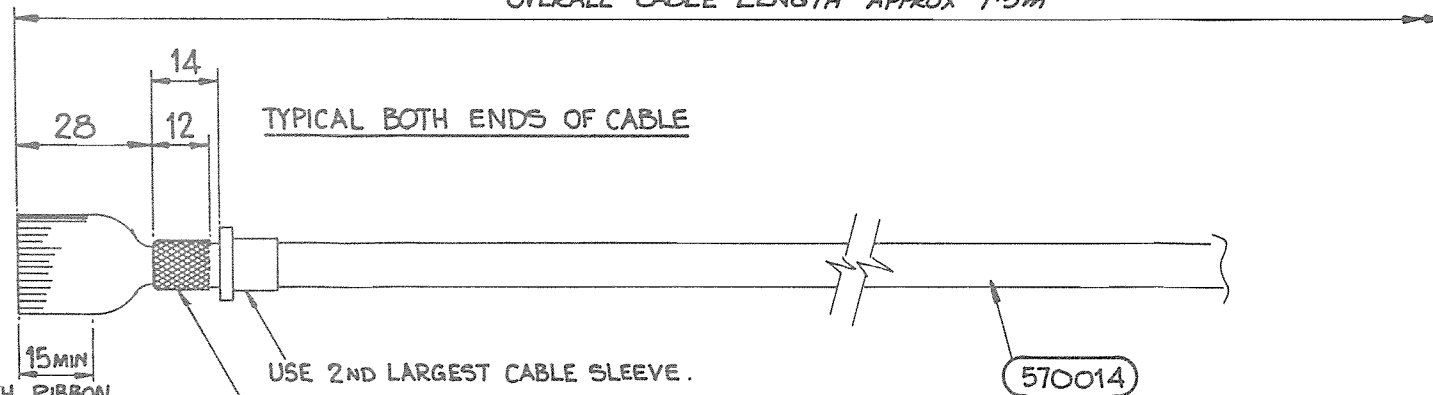

NOTE
CABLE IS MANUFACTURED WITH RIBBON WIRES PART SEPERATED (30mm ON 60mm CENTRES). ENSURE THIS PORTION DOES NOT HAVE WIRES SEPERATED, CUT BACK CABLE UNTIL SUITABLE AREA IS FOUND.

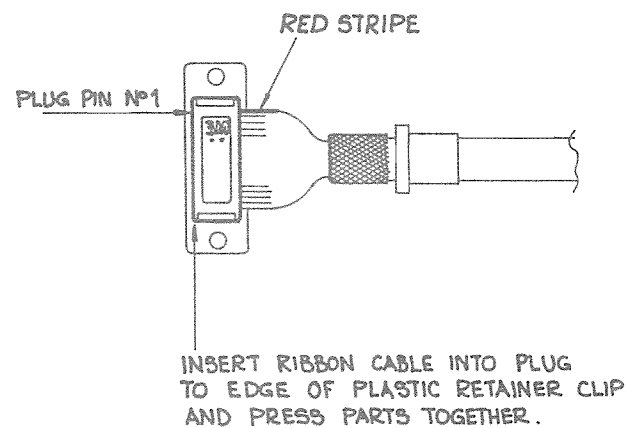

TYPICAL BOTH ENDS OF CABLE

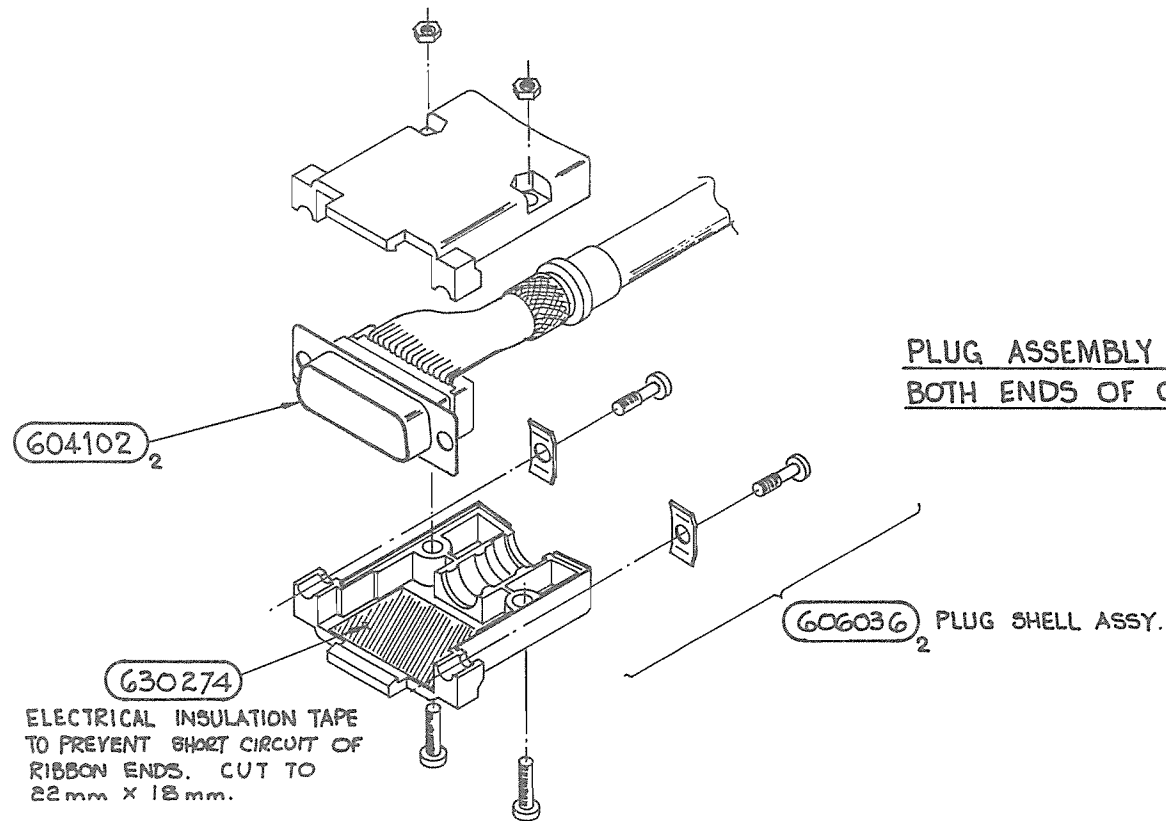

PLUG ASSEMBLY TYPICAL FOR BOTH ENDS OF CABLE.

DESIG	PART NO	DESCRIPTION	PRINC MANUF	MANUF PART NUMBER	CLASS UM	QUANTITY	CHANGES
	560009	CABLE 8 CORE 7/0.2 PVC SC			MM	1500	
	604097	6WAY CABLE MNT PLUG	LEMO	FGG2B306CHAD62	EA	1	
	605182	6WAY CABLE MNT SOCKET	LEMO	FGJ2B306CHJD62	EA	1	
	590055	SLEEVE SILICON 1mm BLK	R S COMPONENTS	399-394	AR	1	

End

DESIG	PART NO	DESCRIPTION	PRINC MANUF	MANUF PART NUMBER	CLASS UM	QUANTITY	CHANGES
	570014	CABLE FLAT 15 WAY ROUND JACKET	3M	3659/15SF	MM	1500	
	604102	PLUG 15WAY DELTA PIN	3M	8215-8009	EA	2	
	606036	CABLE MOUNT MET JUNC SHELL	3M	3357-0215	EA	2	
	630274	TAPE PTFE 0.5mm THK x 30mm	DALAU		AR	1	

End

DESIG	PART NO	DESCRIPTION	PRINC MANUF	MANUF PART NUMBER	CLASS	UM	QUANTITY	CHANGES
	530555	WIRE 24/.2 PVC 1.5KV GRN		DEF61-12				AR 1
	550008	CABLE 2 CORE 50/.025 RUBBER	STC	42812X				MM 1
	590030	SLEEVE HS 18.0MM BLK	HELLERMAN	SFM18-6BK				AR 1
	920166	PLUG BUNCH PIN 4MM DIA BRN	DELTRON	555/BRN BNP				EA 2
	920169	PLUG BUNCH PIN 4MM DIA BLU	DELTRON	555/BLU BNP				EA 2
	920214	PLUG BUNCH PIN 4MM DIA GRN	DELTRON	555/GRN BNP				EA 2

End

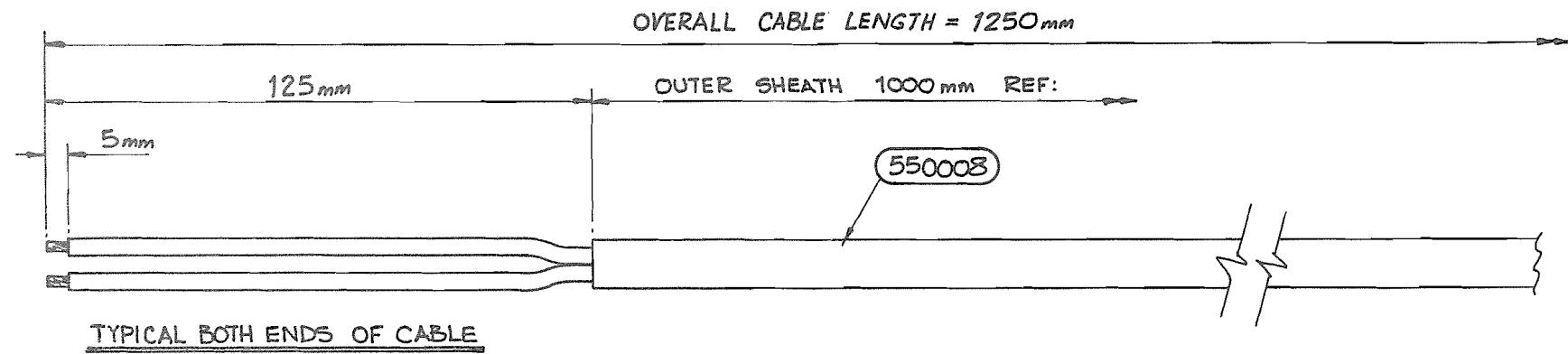

TYPICAL BOTH ENDS OF CABLE

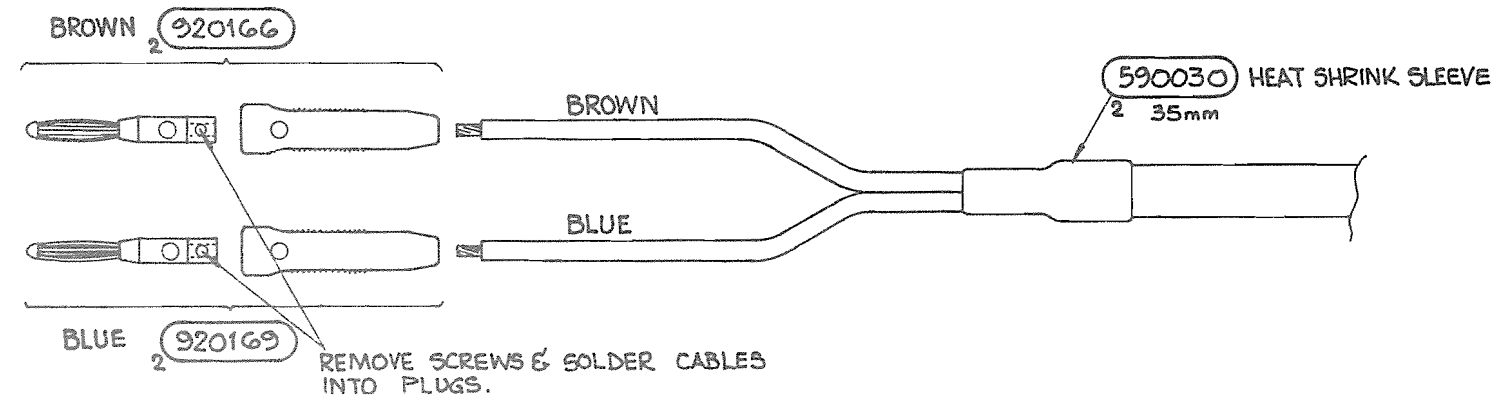

TYPICAL BOTH ENDS OF CABLE

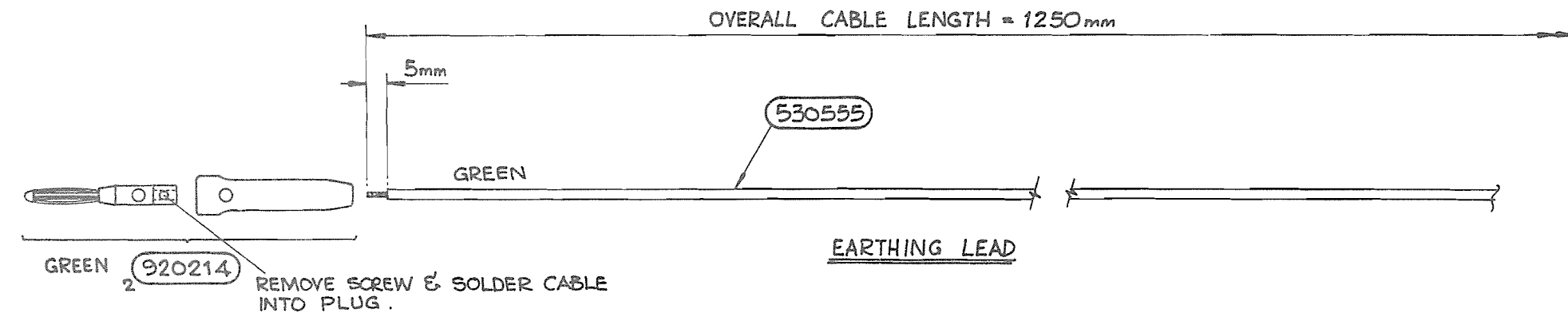

EARTHING LEAD

TYPICAL BOTH ENDS OF CABLE



Wavetek Calibration Division Sales and Service Representatives Worldwide

ARGENTINA

Reycom Electronica SA
B de Irigoyen 972 2DO Piso C,
1304 Buenos Aires
Tel: 54 1304 2018
Telex: -----
Fax: 54 1304 2010

AUSTRALIA

Scientific Devices Pty. Ltd
PO Box 63, 2 Jacks Road,
South Oakleigh, Victoria 3167
Tel: 61 3 579 3622
Telex: AA92724
Fax: 61 3 579 0971

AUSTRIA

Walter Rekirsch, und Co.
Vertriebs KG, Obachgasse 28, 1220 Wien
Tel: 43 1 259 7270
Telex: -----
Fax: 43 1 259 7275

BELGIUM

Air-Parts International B. V.
Avenue Huart-Hamoirlaan 1,
Box 34, 1030 Bruxelles
Tel: 32 2 241 6460
Telex: -----
Fax: 32 2 241 8130

BOLIVIA

Electronic Marconi SRL
Colle Yanacocho 337,
Cajon Postal 143, La Paz
Tel: 591 2 352 574
Telex: -----
Fax: 591 2 314 540

BRAZIL

Sistrionics Instrumentacao
E Sistemas
Av. Alfredo Egidio de Souza Aranha
75 3/4 Andares. Santo Antonio,
04726-170 Sao Paulo
Tel: 55 11 247 5588
Telex: 55 11 57155 SNCS
Fax: 55 11 523 8457

CHILE

Avantec Ltda
PO Box 1087
Fidel Oteiza 1921 - Of. 1106
Providencia - Santiago
Tel: 56 2 341 1021
Telex: -----
Fax: 56 2 341 1020

CHINA

Wavetek Corporation;
Beijing Representative Office.
27/F Room GH, CITIC Building,
19 Jianguomenwai Dajie,
Beijing 100004
Tel: 861 500 2255 Ext. 2768
Telex: -----
Fax: 861 500 8199

CHINA (Service Only)

Tianjin Zhong Huan
Scientific Instruments Corp.
No. 59 Zhao Jia Chang Street,
Hong Qiao Section, Tianjin
Tel: 753732
Telex: -----
Fax: 22 252 625

DENMARK

Instrutek-Periferi A/S,
Christiansholmsgade
8700 Horsens
Tel: 45 75 611 100
Telex: -----
Fax: 45 75 615 658

EASTERN EUROPE

Wavetek GmbH
Meidlinger,
Hauptstraße 46,
A-1120 Wien,
Austria
Tel: 43 1 813 5628
Telex: ---
Fax: 43 1 813 2426

EGYPT & MIDDLE EAST

Shimco Engineering Consultants
8, Abani Pasha Street,
Zizinia, Alexandria
Tel: 20 3 586 4999
Telex: -----
Fax: 20 3 586 6200

FINLAND

Finn Metric OY
Scandia Metric Group
PO Box 4, Riihitonuntie 2
FIN-02201 Espoo
Tel: 358 0 423 911
Telex: -----
Fax: 358 0 426 967

FRANCE

M. B. Electronique
606 Rue Fourny-BP31, Z.I. de Buc,
78533 BUC CEDEX
Tel: 33 1 39 56 81 31
Telex: 842 695414
Fax: 33 1 39 56 53 44

GERMANY

WAVETEK GmbH
Gutenbergstraße 2-4,
D-85737 Ismaning
Tel: 49-89-99641-0
Fax: 49-89-99641-160

GREECE

American Technical
Enterprises SA
PO Box 3156
Agiou Konstantinou 39,
Athens 10210.
Tel: 30 1 524 0620
30 1 524 0740
Telex: 863 216046 ATE GR
Fax: 30 1 524 9995

HONG KONG

Wavetek Asia Pacific Sales Office
Room 3A, HKPC Building,
78 Tat Chee Avenue,
Kowloon, Hong Kong
Tel: 852 788 6221
Telex: -----
Fax: 852 788 6220

HONG KONG

Euro Tech (Far East) Ltd
18/F., Gee Chang Hong Centre,
65 Wong Chuk Hang Road,
Hong Kong
Tel: 852 814 0311
Telex: 780 72449 EFELD HX
Fax: 852 873 5974

INDIA

Technical Trade Links

- Deodahar Centre,
424 Marol Maroshi Road,
Andheri (East), Bombay 400 059
Tel: 91 22 832 2412
91 22 834 2204
Telex: 011 95379261 TTLIN
Fax: 91 22 837 6719
- Flat B, 2nd Floor, Ashoka Centre, 4E/15,
Jhandewalan Extn.,
New Delhi - 110 055
Tel: 91 11 752 7277
Telex: 953 031 61614 APLB IN
Fax: 91 11 752 6036

INDONESIA

C. V. Schmidt Mitra Indonesia
Delta Bldg., Block A, No. 30,
JL Surya Pranoto No 1-9,
Jakarta 10160.
Tel: 62 21 380 7845
Telex: 796 46729 SCHMIDIA
Fax: 62 21 380 7847

IRELAND

Euro Electronic Systems
Unit 1, Sandyford Park,
Sandyford Ind. Est., Dublin 18.
Tel: 353 12 952 326
Telex: -----
Fax: 353 12 952 246

ISRAEL

DAN-EL Technologies Ltd.
PO Box 13144, Office 60,
Tel-Aviv 61131.
Tel: 972 3 647 8770
Telex: 342105
Fax: 972 3 647 8771

ITALY

DELO Instruments
Via Piemonte 14
20090 Fizzonasco Pieve E,
Milano
Tel: 39 2 907 22441
Telex: -----
Fax: 39 2 907 22742

JAPAN

Yokogawa Electric Corporation
Kofu General Business Division
155 Takamuro-Cho
Kofu-Shi, Yamanashi-Ken 400
Tel: 0552 43 0332
Telex: -----
Fax: 0552 43 0399

KOREA

Myoung Corporation
Yeo Eui Do, PO Box 14, Seoul
Tel: 82 2 784 9942
Telex: K 24283 MYOUNG
Fax: 82 2 784 2387

MALAYSIA

Schmidt Scientific SDN BHD
13th Floor, Wisma Mirama,
Jalan Wisma Putra,
P. O. Box 10592,
50718 Kuala Lumpur.
Tel: 60 3 242 7122
Telex: 30035 SCHMID MA
Fax: 60 3 248 5143

MEXICO

Mexitex, S.A.
Porfirio Diaz 53, Col. Del Valle,
APDO, Postal 12-1012
Mexico, D.F. 03100
Tel: 525 575 9929
525 575 0312
525 575 0269
Telex: 177 3239 MEXIME
Fax: 525 575 9981

MOROCCO

Minhol SA
64 Rue El Mortada,
Casablanca 02.
Tel: 212 2 25 52 92
Telex: CC24064
Fax: 212 2 25 49 92

NETHERLANDS

Air Parts International BV
PO Box 255, Kalkovenweg 12, 2400 AG
Alphen aan den Rijn
Tel: 31 1 1720 43221
Telex: 844 39564
Fax: 31 1 1720 20651

NEW ZEALAND

G. T. S. Engineering Ltd
5 Porters Avenue, Eden Terrace,
PO Box 9613 Newmarket Auckland
Tel: 64 9 309 2464
Telex: -----
Fax: 64 9 309 2968

NORWAY

Metric A/S
Scandia Metric Group
Postboks 46, Holmlia
Nordasveien 5
N-1201 Oslo 12.
Tel: 47-22-61-1070
Telex: ---
Fax: 47-22-61-7492

PHILIPPINES

Avesco Marketing Corp.
PO Box 3531,
Manila
Tel: 63 2 912 8881
Telex: ---
Fax: 63 2 912 2999

PORTUGAL

Decada SA
Rua Margarida Palla. 11B
Miraflores, 1495 Alges
Lisboa.
Tel: 351 1 410 3420
Telex: 832 15515 ESPBPC
Fax: 351 1 410 1844

SAUDI ARABIA

Electronic Equipment Marketing Co.
PO Box 3750,
30th Street, Olaya Road
Riyadh 11481,
Tel: 966 1 477 1650
Telex: 928 401120 ZUHAIRSJ
Fax: 966 1 478 5140

SINGAPORE (1)

Wavetek Asia-Pacific Pte Ltd
51 Goldhill Plaza #14-04/05
Singapore 1130
Tel: 65 356 2522
Fax: 65 356 2523

SINGAPORE (2)

O'Connor's Singapore Pte Ltd
O'Connor's House,
98, Pasir Panjang Road,
Singapore 0511
Tel: 65 473 7944
Telex: -----
Fax: 65 472 4508

SOUTH AFRICA

Altech Instruments Pty Ltd
PO Box 2097,
Boksburg 1460
Transvaal
Tel: 27 11 914 4525
Telex: -----
Fax: 27 11 914 1475

SPAIN

Equipos y Sistemas SA
c/o Apolonio Morales 13B,
28036 Madrid
Tel: 34 1 359 0088
Telex: 42856
Fax: 34 1 359 0298

SWEDEN

Kaliber AB
Maltesholmvägen 136,
Box 4443 S-165 15 Hasselby
Stockholm
Tel: 010 468 380 350
Telex: -----
Fax: 010 468 380 320

SWITZERLAND

Computer Controls AG
Probusweg 2, CH-8057 Zurich
Tel: 41 1 313 0616
Telex: -----
Fax: 41 1 313 0622

TAIWAN

Quatek Co., Ltd.
3rd Fl., Spring Plaza, 6,
Section 3,
Min Chuan E. Road.,
Taiwan, R.O.C.
Tel: 886 2 501 7065
Telex: -----
Fax: 886 2 509 5329

THAILAND

Trane International Co. Ltd
13 Soi Krungthonburi 4
Krungthonburi Road, Klongsan,
PO Box 6-49 BKK,
10600 Thailand.
Tel: 662 438 0038
Telex: -----
Fax: 662 438 6098

TURKEY

Turkelek
Hatay Sokak 8
06650 Ankara,
Tel: 90 312 418 9483
Telex: -----
Fax: 90 312 417 5529

UNITED KINGDOM

Wavetek Calibration Division
52 Hurricane Way,
Norwich Airport,
Norwich, Norfolk NR6 6JB, England
Tel: 44 1603 404 824
Telex: 851 975173
Fax: 44 1603 483 670

UNITED STATES of AMERICA

- Wavetek Calibration Division (Service Only): c/o Wavetek Communication Division
5808 Churchman Bypass,
Indianapolis, IN 46203
Tel: 317 788 5960
Telex: 810 341 3226
Fax: 317 788 5999
- Wavetek Eastern Area Sales
35 Pinelawn Road, Suite 209W,
Melville, NY 11747
Tel: 516 454 8440
Telex: -----
Fax: 516 454 8446
- Wavetek Western Area Sales & Service
9145 Balboa Avenue,
San Diego, CA 92123
Tel: 619 279 2200
Telex: -----
Fax: 619 450 0325

VENEZUELA

Onimex C.A.
2 Avenue Entre,
3 & 4 Transversal,
Los Palos Grandes,
Apartado Postal 61421
Caracas 1062,
Tel: 58 2 285 8641
Telex: -----
Fax: 58 2 285 8417

For customers in countries not listed, please contact WAVETEK CALIBRATION DIVISION in the United Kingdom:

Wavetek Calibration Division
52 Hurricane Way,
Norwich Airport,
Norwich, Norfolk NR6 6JB, England
Tel: 44 1603 404 824
Telex: 851 975173
Fax: 44 1603 483 670

DATRON INSTRUMENTS FAILURE REPORT.

Please complete all sections and return with your instrument.

Company:
Division: Department/Mail Stop
User, Name: Telephone Ext
Serial number:
Datron Return Authorisation number Date of failure

Brief description of fault:
.....
.....
.....

Fault details:

is the fault present on all ranges? Yes No Not Applicable

if no describe:

is the fault present on all functions? Yes No Not Applicable

is the fault: Permanent Intermittent

if intermittent under what conditions does the fault re-appear
.....

Does the instrument pass 'self test?' Yes No

Any fail/error message displayed:

Now: Yes No if yes describe

At the time of fault: Yes No

if yes describe
.....

Prior to fault: Yes No

if yes describe
.....

Is the instrument used on I.E.E.E 488 bus? Yes No

Is the instrument normally enclosed in a rack? Yes No

Approximate ambient temperature

TERMS AND CONDITIONS OF SALE

1. GENERAL

The acceptance of a quotation, of any goods supplied, advice given or service rendered includes the acceptance of the following terms and conditions and no variation of or addition to the same shall be binding upon us unless expressly agreed in writing by us. Any order shall be subject to our written acceptance.

2. QUOTATION

Unless previously withdrawn our quotation is open to acceptance in writing within the period stated or where no period is stated within thirty (30) days after its date. We reserve the right to correct any errors or omissions in our quotation. Unless otherwise stated all quotations are firm and fixed. The prices quoted are based on manufacture of the quantity and type ordered and are subject to revision when interruptions, engineering changes or changes in quantity are caused or requested by the customer.

3. LIABILITY FOR DELAY

Any delivery times quoted are from the date of our written acceptance of any order and on receipt of all information and drawings to enable us to put the work in hand. Where delivery is to take place by instalments each such instalment shall constitute a separate contract. We will use our best endeavours to complete delivery of the goods or services in the period stated but accept no liability in damages or otherwise for failure to do so for any cause whatsoever. In all cases of delay the delivery time shall be extended by reasonable period having regard to the cause of delay.

4. PAYMENT

Payment shall be made net cash within thirty (30) days of delivery or in accordance with the payment terms set out in the quotation. Unless specifically stated to the contrary payment shall be in pounds sterling. In the event of any payment to us being overdue we may without prejudice to any other right suspend delivery to you or terminate the contract and/or charge you simple interest on overdue amounts at the rate of 2.5% above the ruling Bank of England Minimum Lending Rate. No payment to us shall in any circumstance be offset against any sum owing by us to you whether in respect of the present transaction or otherwise.

5. INSPECTION & TEST

All goods are fully inspected at our works and where practicable subjected to our standard tests before despatch. If tests are required to be witnessed by your representative notice of this must be given at the time of placing the order and notice of readiness will then be given to you seven (7) days in advance of such tests being carried out. In the event of any delay on your part in attending such tests or in carrying out inspection by you after seven (7) days notice of readiness the tests will proceed in your absence and shall be deemed to have been made in your presence and the inspection deemed to have been made by you. In any event you shall be required promptly after witnessing a test or receiving test results of witnessed or unwitnessed tests to notify us in writing of any claimed defects in the goods or of any respect in which it is claimed that the goods do not conform with the contract. Before you become entitled to reject any goods we are to be given reasonable time and opportunity to rectify them. You assume the responsibility that the goods stipulated by you are sufficient and suitable for your purpose and take all steps to ensure that the goods will be safe and without risk to health when properly used. Any additional certification demanded may incur extra cost for which a special quotation will be issued.

6. DELIVERY AND PACKING

All shipments are, unless otherwise specifically provided, Ex-works which is the address given on the invoice. An additional charge will be made for carriage and insurance as necessary with the provision that all shipments shall be insured and this insurance expense shall be paid by the purchaser. Where special domestic or export packing is specified a charge will be made to cover the extra expense involved.

7. DAMAGE IN TRANSIT

Claims for damage in transit or loss in delivery of the goods will only be considered if the carriers and ourselves receive notice of such damage within seven (7) days of delivery or in the event of loss of goods in transit within fourteen (14) days of consignment.

8. TRANSFER OF PROPERTY & RISK

Title and property of the goods shall pass when full payment has been received of all sums due to us whether in respect of the present transaction or not. The risk in the goods shall be deemed to have passed on delivery.

9. WARRANTY

We agree to correct, either by repair, or at our election, by replacement, any defects of material or workmanship which develop within the warranty period specified in the sales literature or quotation after delivery to the original purchaser. All items claimed defective must be promptly returned to us carriage paid unless otherwise arranged and will be returned to you free of charge. Unless otherwise agreed no warranty is made concerning components or accessories not manufactured by us. We will be released from all obligations under warranty in the event of repairs or modifications made by persons other than our own authorised service personnel unless such repairs are made with our prior written consent.

10. PATENTS

We will indemnify you against any claim of infringement of Letters Patent, Registered Design, Trade Mark or Copyright (published at the date of the contract) by the use or sale of any goods supplied or service rendered by us to you and against all costs and damages which you may incur and for which you may become liable in any action for such infringement. Provided always that this indemnity shall not apply to any infringement which is due to our having followed a design or instruction furnished or given by you or to the use of such goods or service in association or combination with any other article, material or service not supplied by us. This indemnity is conditional on your giving to us the earliest possible notice in writing of any claim being made or action threatened or brought against you and on your permitting us at our own expense to conduct litigation that may ensue and all negotiations for a settlement of the claim or action. You on your part warrant that any design or instruction furnished or given by you shall not cause us to infringe any Letter Patent, Registered Design, Trade Mark or Copyright in the execution of your order.

11. DOCUMENTATION

All drawings, plans, designs, software specifications, manuals and technical documents and information supplied by us for your use or information shall remain at all times our exclusive property and must not be copied, reproduced, transmitted or communicated to a third party without our prior written consent.

12. FRUSTRATION

If any contract or any part of it shall become impossible of performance or otherwise frustrated we shall be entitled to a fair and reasonable proportion of the price in respect of the work done up to the date thereof. For this purpose any monies previously paid by you shall be retained against the sum due to us under this provision. We may dispose of the goods as we think fit due allowance being made to you for the net proceeds thereof.

13. BANKRUPTCY

If the purchaser shall become bankrupt or insolvent, or being a Limited Company commence to be wound up or suffer a Receiver to be appointed, we shall be at liberty to treat the contract as terminated and be relieved of further obligations. This shall be without prejudice to our right to claim for damages for breach of contract.

14. LEGAL INTERPRETATION

Any contract will be deemed to be made in England and shall be governed and construed for all purposes and in all respects in accordance with English Law and only the Courts of England shall have jurisdiction.