

OPERATOR'S MANUAL

Model 295
Synthesized 50 MHz Multichannel
Arbitrary Waveform Generator

For Model 295 Maintenance Information, refer to
separate Maintenance Manual, P/N 1006-00-0675-02.

© 1992 Wavetek

This document contains information proprietary
to Wavetek and is provided solely for instrument
operation and maintenance. The information in
this document may not be duplicated in any
manner without the prior approval in writing from
Wavetek.

Wavetek
Instruments Division
9045 Balboa Ave.
San Diego, CA 92123
Tel: (619) 279-2200
800-223-9885
Fax: (619) 565-7942

Manual Revision D,9/93
Manual Part Number 1006-00-0675-01

WARRANTY

Wavetek warrants that all products manufactured by Wavetek conform to published Wavetek specifications and are free from defects in materials and workmanship for a period of one (1) year from the date of delivery when used under normal operating conditions and within the service conditions for which they were furnished.

The obligation of Wavetek arising from a Warranty claim shall be limited to repairing, or at its option, replacing without charge, any product which in Wavetek's sole opinion proves to be defective within the scope of the Warranty. In the event Wavetek is not able to modify, repair or replace non-conforming defective parts or components to a condition as warranted within a reasonable time after receipt thereof, Buyers shall be credited for their value at the original purchase price.

Wavetek must be notified in writing of the defect or nonconformity within the Warranty period and the affected product returned to Wavetek's factory or to an authorized service center within thirty (30) days after discovery of such defect or nonconformity.

For product warranties requiring return to Wavetek, products must be returned to a service facility designated by Wavetek. Buyer shall prepay shipping charges, taxes, duties and insurance for products returned to Wavetek for warranty service. Except for products returned to Buyer from another country, Wavetek shall pay for return of products to Buyer.

Wavetek shall have no responsibility hereunder for any defect or damage caused by improper storage, improper installation, unauthorized modification, misuse, neglect, inadequate maintenance, accident or for any product which has been repaired or altered by anyone other than Wavetek or its authorized representative and not in accordance with instructions furnished by Wavetek.

Exclusion of Other Warranties

The Warranty described above is Buyer's sole and exclusive remedy and no other warranty, whether written or oral, is expressed or implied. Wavetek specifically disclaims the implied warranties of merchantability and fitness for a particular purpose. No statement, representation, agreement, or understanding, oral or written, made by an agent, distributor, representative, or employee of Wavetek, which is not contained in the foregoing Warranty will be binding upon Wavetek, unless made in writing and executed by an authorized Wavetek employee. Under no circumstances shall Wavetek be liable for any direct, indirect, special, incidental, or consequential damages, expenses, losses or delays (including loss of profits) based on contract, tort, or any other legal theory.

Contents

Section 1 Introduction

The Model 295	1-1
Organization of This Manual	1-1

Section 2 Initial Preparation

Organization Of This Section	2-1
Receiving And Inspecting Shipments	2-1
Returning Equipment For Repair	2-1
Preparation For Storage Or Shipment	2-2
Packaging	2-2
Storage	2-2
Preparation For Use	2-2
Fuse Replacement	2-2
Battery	2-3
Installation	2-3
Mounting Ears and Rack Slides	2-3
Arb Channel Board Installation	2-4
Mouse Connection	2-4
IEEE - 488 Connector	2-4
RS-232 Connector	2-5
Connecting the RS-232-C Interface	2-6
Initial Turn-On	2-7
Autocal and Calibration Procedure	2-8
Error Messages	2-8
Functional Checkout	2-8
Initial Setup	2-8
Self Test	2-9
Routine Maintenance	2-15

Section 3 Introduction To The Model 295

Overview of the Model 295	3-1
Using the Model 295	3-1
Help Menu	3-1
Initial Setup	3-2
The Main Screens	3-3
Screen Items	3-6
Selector Fields	3-6
Boolean Fields	3-6
Edit Fields	3-6
Flashing Items	3-7
Using the Mouse and Keypad	3-7
Selecting Items Using a Mouse	3-7
Selecting Items Using the Front Panel Keys	3-9
Using the Keypad to Change Values	3-10
Changing a Value	3-10

Contents (Cont.)

Using Both the Mouse and Keypad	3-11
Entering Names	3-11
Using The Mouse To Enter Names	3-11
Using the Arrow Keys to Enter Names	3-11
Getting Help	3-12
Error Messages	3-13
Using the Channel Setup Screen	3-13
Channel Setup Screen Basics	3-13
Select the Channel	3-14
Turn On the Output	3-14
Turn On the Sync Out	3-15
Select a Function	3-15
Change the Mode	3-16
Changing the Frequency	3-16
Changing the Amplitude	3-17
Storing a Setup	3-18
Using Waveforms	3-20
Creating an Arbitrary Waveform	3-20
Using Sequences	3-29
Creating a Sequence	3-29
Summary of Sequence Example	3-38
Editing a Sequence	3-39

Section 4 Operation Reference

Introduction	4-1
The Front Panel	4-1
Rear Panel	4-3
Arb Channel Board	4-4
Channel Setup Screen	4-6
Channel Numbers	4-6
Changing Channel Numbers	4-6
Output On/Off	4-7
Modes	4-7
Continuous	4-7
Triggered	4-7
Gated	4-8
Sweep Cont	4-9
Sweep Trig	4-9
Sweep Hold	4-9
Functions	4-9
Standard Functions	4-9
User-defined Functions	4-9
Function Selection	4-10
Sine	4-10
Triangle	4-10
Square	4-11
Positive Ramp	4-11
Negative Ramp	4-11
Sinc (Sin(X)/X)	4-11
Positive Haversine	4-11

Contents (Cont.)

Negative Haversine	4-11
Random	4-11
Waveform	4-11
Sequence	4-12
Amplitude	4-13
Offset	4-14
Frequency	4-14
Frequency Field	4-14
Unit of Measure Field	4-15
Channel Setup Menu Field	4-15
Filters	4-16
Modulation	4-16
Amplitude Modulation	4-17
Suppressed Carrier Modulation	4-17
Sweep	4-18
Clock BNC	4-19
High Frequency Clock Output	4-20
Internal Clock Output OFF	4-20
Internal Clock Output ON	4-20
External Clock	4-20
Phase	4-21
Sync Marker	4-22
Trigger Setup	4-23
Channel "Button"	4-23
Mode Field	4-23
Count Field	4-24
Function Field	4-24
Trigger Start (Source) Field	4-25
System Trigger Input BNC	4-25
Master Trigger (Ch1 Internal)	4-26
Channel's External Trig In BNC	4-26
Channel 2 Trigger Output	4-26
Channel 3 Trigger Output	4-26
Channel 4 Trigger Output	4-26
Previous Channel's Trig Out	4-27
Advance Field	4-27
Trigger Out Field	4-27
Trigger Setup Menu Button	4-28
System Trigger Level	4-28
Channel Trigger Polarity	4-28
Arbitrary Waveforms..	4-29
Active (Waveform Information)	4-30
Active Waveform	4-30
Waveform or Segment Name	4-30
Chan	4-30
Points:	4-30
Source:	4-31
Marker Position	4-31
Waveform Limits	4-32
Channel Memory	4-32
Load Waveforms	4-33
Loading Waveform Files from the Disk Drive	4-34
Using WaveForm DSP™	4-34
Using a Spreadsheet Application or ASCII File	4-34

Contents

Edit Waveforms	4-35
Waveform Catalog	4-35
Information Message	4-35
Scope Edit Screen	4-37
Waveform Name	4-37
Points	4-37
Cursor Address and Data	4-37
Block Start, Length, and Height	4-38
Block Selection	4-38
Editing Tools	4-39
Other Editing Tools	4-45
Point Editing	4-47
Line List Example	4-48
Scope Edit Menu "Button"	4-49
End Edit	4-49
Store on Disk	4-49
Store in Battery-Backed RAM	4-50
Keep But Don't Store	4-50
Discard	4-50
And Rename	4-50
Resize	4-51
Current Number of Points	4-51
New Number of Points	4-51
Done	4-51
Cancel	4-51
Units	4-51
Amplitude	4-52
Offset	4-52
Sample Rate	4-52
Done	4-52
Cancel	4-52
Z-Axis	4-52
Mouse Grid	4-53
Copy Waveforms	4-53
Delete Waveforms	4-54
New (Create) Waveforms	4-56
Waveform Name	4-56
Information and Scope Edit Screens	4-57
Instrument	4-73
Stored Setups	4-73
Store	4-73
Recall	4-75
Copy	4-76
Delete	4-77
Multi-Channel	4-78
Channel Group - Clocks	4-78
Channel Group Screen	4-79
Phase Lock	4-79
Analog Sum	4-80
Summed Output	4-80
Attenuator	4-80
Channel Sum Input	4-80
Reset	4-81
Current Channel:	4-81

Contents

Full Instrument:	4-81
Backup RAM:	4-82
Options	4-82
Test/Cal	4-83
Perform Self-Test	4-83
Perform AutoCal	4-83
Manual Calibration	4-83
Done	4-83
10 MHz Ref	4-84
Utilities screens	4-85
Files	4-85
Source	4-85
Types	4-86
Listing	4-86
Copy and Rename	4-86
Delete	4-86
Done	4-86
Files Menu Button	4-86
Disk	4-86
RAM	4-87
LCD/Mouse/Beeper	4-88
Viewing Angle	4-88
Blink Time	4-88
Mouse	4-88
Beeper	4-89
Screen Colors	4-89
Remote	4-89
Remote Source	4-90
Currently	4-90
RS-232	4-90
IEEE-488 Information	4-90
Date & Time	4-91
Version Report	4-93

Section 5 Remote Operation

Introduction	5-1
SCPI	5-1
IEEE 488.2	5-1
IEEE 488.1	5-1
IEEE-488.1. (GPIB) Setup	5-1
Hardware Setup	5-1
Instrument Setup	5-2
RS-232 Setup	5-3
Hardware Setup	5-3
Instrument Setup	5-3
Commands	5-4
Remote Programming	5-4
SCPI Command Summary	5-4
Long and Short Form Keywords	5-5
SCPI Command Tree	5-10
Command Message Format	5-10
Program Message Unit	5-10

Contents (Cont.)

Program Message	5-10
Program Message Delimiters	5-10
Program Data (Parameter Values) Forms	5-11
Program Message Terminators	5-11
Queries	5-11
SCPI Commands	5-13
CALibration	5-13
INITiate<n>	5-16
MMEMory	5-16
OUTPut<n>	5-18
RESet<n>	5-19
(SOURce<n>)	5-20
SYSTEM	5-28
TEST<n>	5-30
TRACe<n>	5-31
TRIGger<n>	5-34
DISPlay	5-35
HVOLTage<n>	5-36
STATus	5-37
IEEE 488.2 Common Commands	5-38
High Speed Binary Waveform Transfer	5-40
RS-232-C Programming	5-41
Baud Rate Setting	5-41
General RS-232-C Information	5-41
RS-232-C Terminator Characters	5-43
Sending Waveforms over the RS-232-C Interface	5-43
Reading Waveforms over the RS-232-C Interface	5-43
GPIB Error Handling and Status Reporting	5-43
Resuming Local Operation	5-47

Appendix A Specifications

A.1 THE MODEL 295	A-1
A.2 SPECIFICATIONS	A-2
A.2.1 Standard Waveforms (Functions)	A-2
A.2.2 User-Defined (Arbitrary) Waveform Creation and Editing ..	A-2
A.2.3 Operational Modes	A-4
A.2.4 Input and Output Specifications	A-6
A.2.4.1 System (Chassis) I/O Connectors	A-6
A.2.4.2 ARB Channel I/O Connectors	A-7
A.2.4.2 Backplane (Intermodule) I/O	A-8
A.2.5 Waveform Characteristics	A-9
A.2.6 Frequency	A-9
A.2.6.1 Arb Clock and Waveform Timing:	A-10
A.2.7 Amplitude	A-10
A.2.8 Offset	A-10
A.2.9 Filtering	A-11
A.2.10 Linked Sequence Operation	A-11
A.2.11 Sweep	A-11
A.2.12 Triggering	A-12
A.2.13 Modulation	A-13
A.2.14 Interchannel Operation	A-13
A.2.15 Clocks	A-14

Contents (Cont.)

A.2.16 Options	A-15
001 Additional 50 MHz Arb Channel Module	A-15
001-EM Additional 50 MHz Arb Channel Module	A-15
001-EM512 Additional 50 MHz Arb Channel Module	A-15
002 3.5" Floppy Disk Drive	A-15
004 Rack Mount/Chassis Slides	A-15
005 Direct DSO Download	A-15
007 High Voltage Module	A-16
A.2.17 AutoCal/Calibration	A-16
A.3 GENERAL	A-16
A.3.1 Front Panel Interface	A-16
A.3.2 Remote Interface	A-17
A.3.3 Physical	A-17
A.3.4 Environmental	A-17

Appendix B Menu - Quick Reference

Appendix C SCPI Command - Quick Reference

SCPI Primer	C-1
Parameters	C-3
Queries	C-3
SCPI Punctuation and Syntax	C-3
Condensed Rules:	C-4
Text Symbols	C-5
TRACE NAMES (numeric label data)	C-5
Example Command Tree	C-5
Example Command Table	C-7
Example Command Syntax Diagrams	C-8
Low Level Interface Commands	C-10
Model 295 SCPI Command Trees	C-11
Model 295 SCPI Command Table	C-11
SCPI Conformance Information	C-20
Model 295 SCPI Version	C-20
Model 295 SCPI Command Syntax	C-20
SCPI Confirmed Commands	C-20
SCPI Approved Commands	C-20
Commands not part of the SCPI Specification	C-20
Incomplete Command Implementation	C-20

Appendix D Rack Ears and Slides Instructions

RackSlide Kit Installation Instructions	D-1
---	-----

Contents (Cont.)

Appendix E Information/Error Messages

Waveform Editing Messages	E-1
Waveform Messages	E-3
Sequences Messages	E-3
Save/Restore Setup File Messages	E-5
File Operations Messages	E-7
Backup RAM Messages	E-8
Channel Grouping Messages	E-8
External Connection Messages	E-9
Instrument Messages	E-10
PCX Image Message	E-11
3V Battery Check Message	E-11
Disk Drive Messages	E-11
Remote Operation Messages	E-14
Self-Test and Calibration Messages	E-14
Internal System Error Messages	E-15

Appendix F DSO Upload-Option 005

F.1 Introduction	F-1
Creating Your Own Drivers	F-1
F.2 Installing the DSO Upload Option	F-1
F.3 Setup and Uploading - DSO Option	F-4
F.3.1 Uploading Waveforms	F-4
F.3.2 Ending The Program	F-5
F.4 DSO Driver Files	F-6
F.5 Creating DSO Drivers	F-6

Appendix G High Voltage Module - Option 007



G.1 Introduction	G-1
G.2 High Voltage Board Installation	G-1
G.3 Operation	G-2
G.3.1 High Voltage Module Connections	G-2
G.3.2 High Voltage Module Screen	G-3
G.3.3 High Voltage Module Operation	G-5
Output Considerations	G-5
Operation	G-6
G.3.4 Remote	G-7

Index

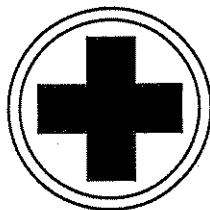
SAFETY FIRST



Protect yourself. Follow these precautions:

- Don't touch the outputs of the instrument or any exposed test wire carrying the output signals. This instrument can generate hazardous voltages and currents
- Don't bypass the power cord's ground lead with two-wire extension cords or plug adapters.
- Don't disconnect the green and yellow safety-earth-ground wire that connects the ground lug of the power receptacle to the chassis ground terminal (marked with  or )
- Don't hold your eyes extremely close to an RF output for a long time. The normally nonhazardous low-power RF energy generated by the instrument could possibly cause eye injury.
- Don't plug in the power cord until directed to by the installation instructions.
- Don't repair the instrument unless you are a qualified electronics technician and know how to work with hazardous voltages.
- Pay attention to the **WARNING** statements. They point out situations that can cause injury or death.
- Pay attention to the **CAUTION** statements. They point out situations that can cause equipment damage.

WARNING

This instrument normally contains a lithium battery. Where lithium is prohibited, such as aboard U.S. Navy ships, verify that the lithium battery has been removed.

Do not recharge, short circuit, disassemble, or apply heat to the lithium battery. Violating this rule could release potentially harmful lithium. Observe polarity when you replace the battery.



Model 295 Synthesized 50 MHz Multichannel Arbitrary Waveform Generator

THE MODEL 295

Combining sophisticated operating capabilities and up to four synthesized 50 MHz Arb channels, with a Graphical User Interface (GUI) that simplifies instrument setup, Wavetek's Model 295 Arbitrary Waveform Generator is a powerful test tool for applications requiring complex waveform generation.

Model 295 is equally at home in an ATE system or on the bench. GPIB (IEEE-488.2/SCPI compatible) and RS-232 interfaces are standard. On the bench, Model 295 Graphical User Interface logically groups and graphically displays all user programmable functions on six main screens. Instrument set up is easy using either the provided mouse or front panel keys to interact with the windows-like screens.

Up to 4 fully independent Synthesized 50 MHz channels can be installed. Each channel provides outputs to 15 Vp-p into 50 ohms (100 Vp-p with Option 007) with 2 ppm frequency accuracy. All channel setup parameters are independently programmable making each channel essentially a stand-alone 50 MHz Arb. Multiple channels can be coupled for synchronous operation with user defined phase offsets between channels.

A set of powerful, easy to use tools make creating and editing (modifying) complex user defined waveforms simple. Waveforms can be downloaded to the Model 295 via the GPIB interface, recalled from Model 295 nonvolatile memory, loaded from disk with the optional DOS format 3.5" floppy disk drive (option 002), or directly downloaded from a variety of digital storage oscilloscopes (with options 002 and 005). Ten commonly used standard waveforms, including pseudo random noise, are provided in nonvolatile memory.

Advanced features include interchannel summing and triggering, numerous non-continuous operating modes including frequency sweep, and Linked Sequence

ORGANIZATION OF THIS MANUAL**Installation and Preparation For Use**

Section 2 tells you how to set up and check out the Model 295 before you use it. It also familiarizes you with the physical setup of the unit.

Introduction To The Model 295

Section 3 describes the fundamentals of the Model 295. If followed sequentially, it provides a tutorial of front panel operations.

Operation Reference

Section 4 provides detailed explanations for every function and feature of the Model 295 using "manual" controls and the mouse. It is organized by Main Screens.

Remote Operation

Section 5 provides an introduction to the set up and operation of the Model 295 from remote sources: RS-232 or IEEE-488.2. It also contains the Model 295 SCPI remote command set and IEEE 488.2 Common Commands.

Specifications

Appendix A, located at the rear of this manual, contains the detailed instrument specifications for the Model 295.

Menu Quick Reference

Appendix B contains quick references illustrating the Model 295 menu structure.

SCPI Quick Reference

Appendix C contains quick references illustrating the Model 295 SCPI command tree. The SCPI information is presented as a "Primer". This appendix also contains the SCPI required Conformance Information.

Rack Ears and Slides Instructions – Option 004

Appendix D contains instructions for mounting the Model 295 in an instrument rack.

Information/Error Messages

Appendix E contains operator instructions relating to the various information screens and error messages that the model 295 might display during "manual" operation.

DSO Upload – Option 005

Appendix F contains operation instructions for using the model 295 to capture waveform data from an external Digitizing Oscilloscope. This capability requires Options 002 and 005 (see Appendix A).

High Voltage Module – Option 007

Appendix G contains operation instructions for installing and using the High Voltage Module to sum channel signals. This capability requires Option 007 (see Appendix A).

Index

Organization Of This Section

You will find in this section:

Receiving and Inspecting Shipments;
Returning Equipment For Repair;
Preparation For Storage or Shipment;
Preparation For Use;
Initial Turn on;
Functional Checkout;
Routine Maintenance.

Receiving And Inspecting Shipments

Use the following steps to inspect a shipment of Wavetek equipment.

1. *Inspect the shipment.* Before continuing with unpacking the instrument, the receiving clerk should check the shipment for missing boxes and inspect each box for damage. If the shipment is damaged have the driver describe the box damage and list shortages on the delivery bill.

If you find unreported shortages or damage, notify the shipper before further unpacking.

2. *After unpacking the boxes.* Save all of the packing material.
3. *Inspect the equipment for damage.* Inspect it carefully, regardless of the condition of the shipping boxes.
4. *If necessary, file a damage claim.* If any damage is found, call the shipper within 10 days and start the claim process.
5. *Call Wavetek.* Call Wavetek's Customer Service department (619-279-2200) and tell them that the equipment arrived damaged.

Returning Equipment For Repair

Use the following steps when returning Wavetek equipment to Wavetek for repair.

1. *Save the packing material.* Always return the equipment to Wavetek in its original packing material and boxes. If you use inadequate packing material, you will have to pay to repair any shipping damage. Carriers will not pay claims on incorrectly packed equipment.

2. *Call Wavetek for a Return Authorization.* Wavetek's customer service representative will ask for the name of the person returning the equipment. Plus the representative will ask for your telephone number, company name, equipment type and serial number, and a description of the problem.

Preparation For Storage Or Shipment

Packaging

If possible, always use the original shipping container. However, when using packing materials other than the original, use the following guidelines:

Wrap the Model 295 in plastic packing material.

Use a double-walled cardboard shipping container.

Protect all sides with shock absorbing material (minimum of 2 inch thick material) to prevent movement of the Model 295 within the container.

Seal the shipping container with approved sealing tape.

Mark "FRAGILE" on all sides, top, and bottom of the shipping container.

Storage

The Model 295 should be stored in a clean, dry environment. In high humidity environments, protect the Model 295 from temperature variations that could cause internal condensation. The following environmental conditions apply to both shipping and storage;

Temperature	-20°C to +70°C
Relative Humidity (sea level)	Less than 95% at +25°C.
Altitude	Less 15,000 feet (4570 meters).
Vibration	Less than 2g.
Shock	Less than 40g.

Preparation For Use

You will find in this paragraph:

Fuse Replacement,
Installation.

Fuse Replacement

The Model 295 accepts a primary input voltage from 90 to 253 Vac, 50/60 Hz. Wavetek ships the Arb with a 4 Ampere, slow blow fuse. The same fuse rating is used for all line voltages. See figure 2-1.

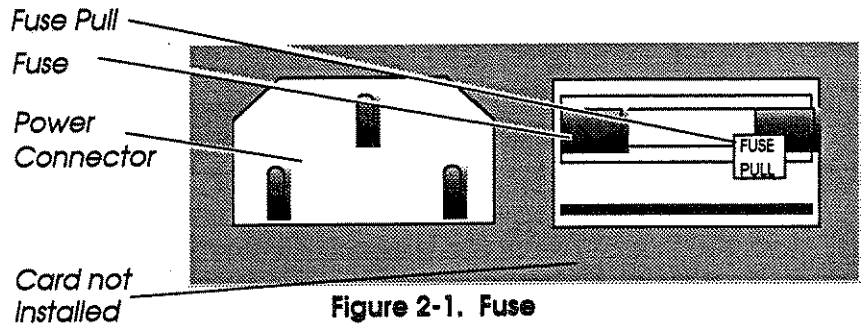

Figure 2-1. Fuse

1. Disconnect the power cord from the instrument and slide fuse holder cover to the left. Next, rotate the FUSE PULL to the left to remove the fuse.

Voltage Range	Fuse
90 to 253 Vac	4A Slo Blo

2. Compare the ampere rating on the fuse to the ampere ratings given above.
 If the fuse is blown, replace it by sliding the new fuse back into the fuse holder.
 If the fuse is not blown and has the right rating, keep it. If the fuse has the wrong rating, replace it by sliding the new fuse back into the fuse holder.
3. Rotate the fuse pull lever to the right back to its normal position and slide the fuse holder's cover to the right closing the door.
4. Connect the ac line cord to the power connector at the rear of the unit and power source.

Battery

Section 2 of the *Model 295 Maintenance Manual* covers battery replacement.

WARNING

This instrument uses an internal battery containing more than 0.2 grams of Lithium. Do not charge or short this battery. A hazard of explosion and or contamination exists.

Installation

For operating convenience, the Model 295 has flip-down feet to elevate the instrument for bench use.

Mounting Ears and Rack Slides

The Model 295 can be rack mounted using the two mounting ears which are available as accessories (Option 004). To install the mounting ears, refer to appendix D of this manual.

Arb Channel Board Installation

To install the Arb Channel Boards,

1. Disconnect the power cord from the instrument.
2. Remove the two screws from the rear panel cover plate. Next, remove the plate.
3. Slide in the Arb Channel Board, and secure the Arb Channel Board in the chassis using the two screws.

If only one channel board is to be installed, it must be installed in the Channel 1 position. See figure 2-2. If two channel boards are to be installed, the boards must go in the slots for Channel's 1 and 2. For three channel boards, use Channels 1, 2, and 3. Finally, for four channel boards, use Channel's 1, 2, 3, and 4.

Refer to Appendix G for installation of a High Voltage Module, Option 007.

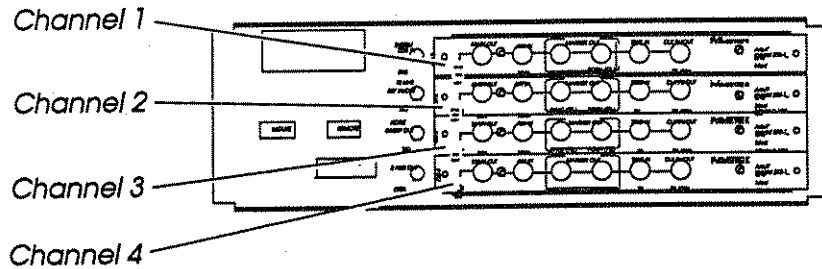

Figure 2-2. Channel Board Locations

Mouse Connection

To install the mouse, connect the nine-pin mouse connector to the rear panel MOUSE connector (DB-9, male) and tighten the thumbscrews. See figure 2-3. The Model 295 is shipped with a two button mouse. If for any reason the mouse must be replaced, the Model 295 accepts any two button serial Microsoft™ compatible mouse with a DB-9 female-pin connector.

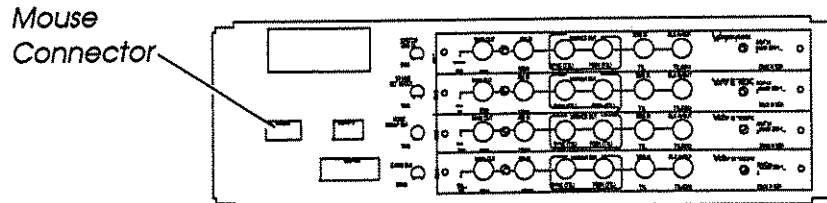

Figure 2-3. Mouse Connection

IEEE - 488 Connector

To connect the Model 295 to a IEEE-488 controller (figure 2-4), using a bus cable with Amphenol 57-10240 or equivalent connectors. You may purchase these cables from Wavetek in two or three meter lengths. For more information on IEEE-488 operation, refer to section 5 of this manual.

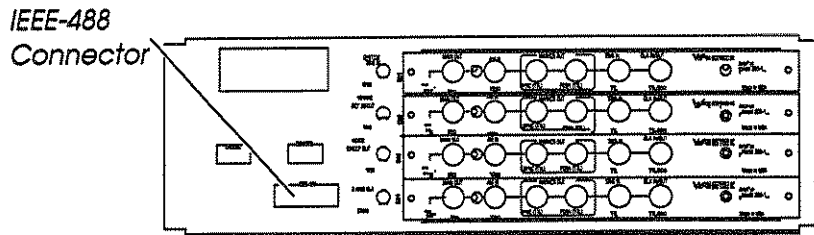

Figure 2-4. IEEE-488 Connector

RS-232 Connector

To connect the Model 295 to a RS-232 device (figure 2-5), using a standard RS-232 cable (interface type E). For more information on RS-232 operation, refer to section 5 of this manual.

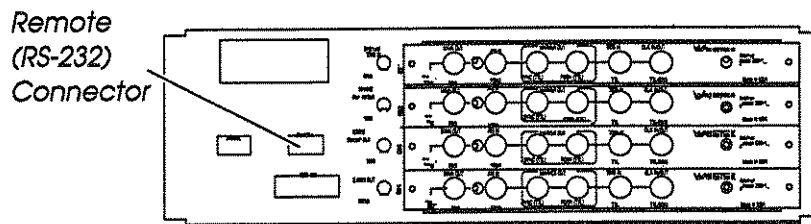

Figure 2-5. RS-232 Connector

The RS-232-C rear panel pin connections and signal names are given in Table 2-1. The panel connector is a DB-9 female connector. The data format is an 8-bit, no parity, one stop bit. The baud rate is selectable, see Figure 4-82 and its associated paragraphs.

Table 2-1. RS-232-C Data In/Out

Name	DCE Direction (Model 295)	DB-9 Pin	DTE Direction (Computer)	DB-25 Pin
TXD ¹	IN	3	OUT	2
RXD ²	OUT	2	IN	3
RTS ³	IN	7	OUT	4
CTS ⁴	OUT	8	IN	5
DSR ⁵	N/C	6	IN	6
SIG GRD	—	5	—	7
RLSD ⁶	N/C	1	IN	8
DTR ⁷	N/C	4	OUT	20

NOTE

Remaining Pins not connected. The Model 295 is configured as the DCE, and uses a DB-9 female connector. The DTE, "data terminal equipment", is generally a computer, and will use either a DB-9 or DB-25 male connector at the RS-232 "serial port". The DTE's connector choice may be configured.

¹Transmit Data

²Receive Data

³Request to Send

⁴Clear to Send

⁵Data Set Ready

⁶Receive Line Signal Detect

⁷Data Terminal Ready

In the following discussion pin numbers refer to the Model 295 DB-9 connector. The 295 serial I/O operates in the DCE configuration, and uses XON/XOFF handshaking. CTS/DTR (hardware) handshaking is not supported. Pins 3 (TXD) and 2 (RXD) are data input and output respectively. Pin 7 tells the Model 295 that the connected device is ready to transmit data. Pin 5 is signal ground and must be used. Pins 1, 4, 6, 8, and 9 are not connected to the Model 295.

Connecting the RS-232-C Interface

Before connecting the Model 295 RS-232-C interface, you must ensure proper configuration and interconnection. The following steps use DB-9 pin-outs when referring to the Model 295, and DB-9 pin-outs followed by DB-25 pin-outs in parenthesis when referring to the other device.

1. Determine if the other device is a DCE device or a DTE device. If this is not explicitly spelled out you will need to look at the pin-outs at its connector. If pin 3 (2) is the data output, the device is a DTE (most computers). If pin 2 (3) is the data output, the device is a DCE (most modems). The other device must appear as a DTE to the Model 295.
2. In most cases a straight-through cable can be used to connect the Model 295 to the DTE. The Model 295 only requires the connection of pins 2, 3, and 7, but the other device may require more. There are many interpretations of the RS-232-C standard, so the following procedure should be used to ensure that the control and handshake signals are properly connected.

- (a) Pin 5 (7), signal ground, is always connected straight-through.

- (b) Pins 2 and 3 are connected straight-through if DCE/DTE configuration is correct. Note that if the DTE has a DB-25 connector, a "straight-through" cable coincidentally swaps these two pins.
- (c) Pin 7 (RTS) of the Model 295 will need to be connected to an output of the other device that indicates readiness for character transmission from that device. If the other device does not support this, XON/XOFF handshaking will be required and pin 7 can be left disconnected.
- (d) Pins 1 and 6 are not connected at the Model 295 and will usually be pulled high at the DTE.

NOTE

Any pins not mentioned in the previous list are not connected in the Model 295 and therefore can be connected to anything if the connections are already present in the cable.

3. The handshaking method is XON/XOFF (see Section 5, RS-232-C Programming, for more information).
4. Set the baud rate on the Model 295 to the highest rate that is available on both the Model 295 and the other device (see Figure 4-82 and its associated paragraphs).
5. Configure the other device for the same baud rate as in step 4, 1 stop bit, 8 data bits, and no parity.

Initial Turn-On

WARNING

The Model 295 is equipped with a three-wire power cable. When connected to a grounded AC power receptacle, this cable grounds the instrument. Do not use extension cords or AC adapters without a ground.

1. Connect the power cable to the power connector on the Model 295 rear panel; see figure 2-6.

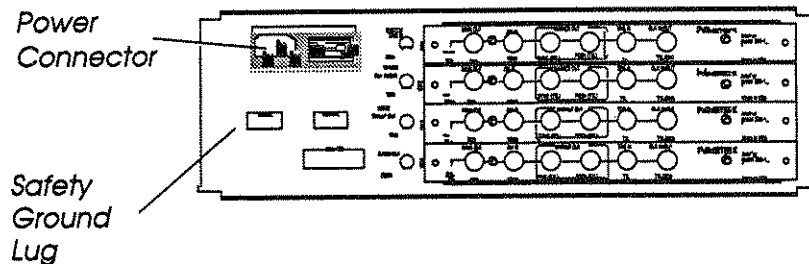

Figure 2-6. Power Connector

2. Press the "POWER" On/Off switch in to turn the unit on (figure 2-7).

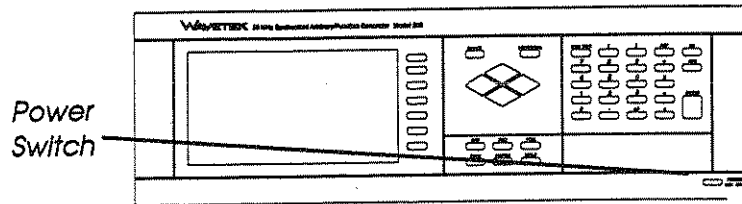

Figure 2-7. Power Switch

When power is first applied, the Model 295 performs a Self-test that checks the internal memory.

Autocal and Calibration Procedure

The Model 295 provides two levels of calibration: Autocal and Calibration Procedure.

Autocal (automatic calibration) provides a quick method of calibrating the Model 295 without using external test equipment. Autocal automatically sets up the instrument and takes internal measurements using internal standards. The Model 295 calculates correction values based on the measurements and stores those values in memory. These correction values are recalled from memory when the unit is powered up. Use Autocal when Model 295 accuracy is critical, after long term instrument storage, following drastic changes in the environment, or when the operator believes Autocal is necessary.

The Calibration Procedure provides a more extensive method of calibrating the Model 295 using external test equipment. The Calibration Procedure requires opening the instrument and making adjustments. Use the Calibration Procedure when the Model 295 has been repaired or when routine calibration is scheduled. Typically, the Model 295 calibration cycle is one year. Section 5 of the Model 295 Maintenance Manual describes the Calibration Procedure.

Error Messages

Some actions cause error or information messages to appear in the display. Appendix E lists the various messages which can appear. Many error messages may appear depending on the operations being performed. For example, parameter errors, waveform errors, sequence errors, etc.

Functional Checkout

The functional checkout provides a quick method of verifying the Model 295 operation. The only test equipment required is a signal source (Wavetek Model 90 or equivalent), an oscilloscope (Tektronix 2445 - dual channel or equivalent), and the appropriate cables and loads.

Initial Setup

1. Connect the Model 295 to the primary power source. Leave all cables disconnected. See Initial Turn On in this section.
2. Turn on the Model 295 by pushing in on the POWER switch.

At power on, the Model 295 performs a Self-test that checks the Model 295 internal memory.

After a successful Self-test, the Model 295 briefly displays its initial screen

(figure 2-8) followed by the Channel Setup screen (see figure 2-9).

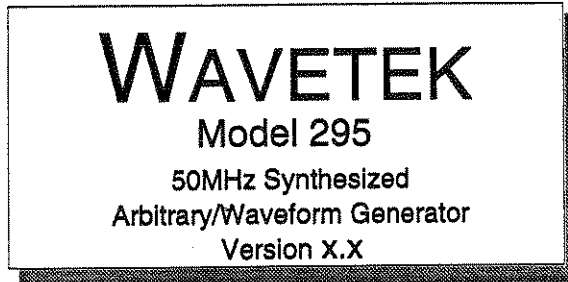

Figure 2-8. Initial Screen

Self Test

After the Model 295 has warmed up for at least 20 minutes, perform the following steps to Self Test the unit:

1. Press the INSTRUMENT key on the front panel.
2. Press "menu" and select Test /Cal from the menu.
3. Select Self Test from the pop-up menu. Select DONE as the results of each channel's Self Test is displayed.

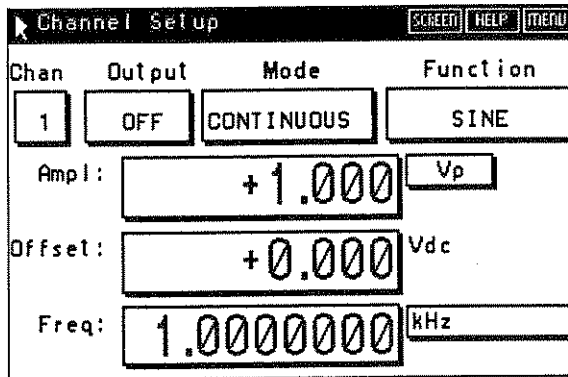

Figure 2-9. Channel Setup Screen

The Channel Setup screen illustrated is the default Model 295 start-up screen.

3. **Arb Channel 1 Connections.** Connect the Main Out and Sync Out from Arb Channel 1 to channel 1 and Trigger input connectors, respectively, on the scope. Be sure to properly terminate each output with 50Ω terminations. See figure 2-10.

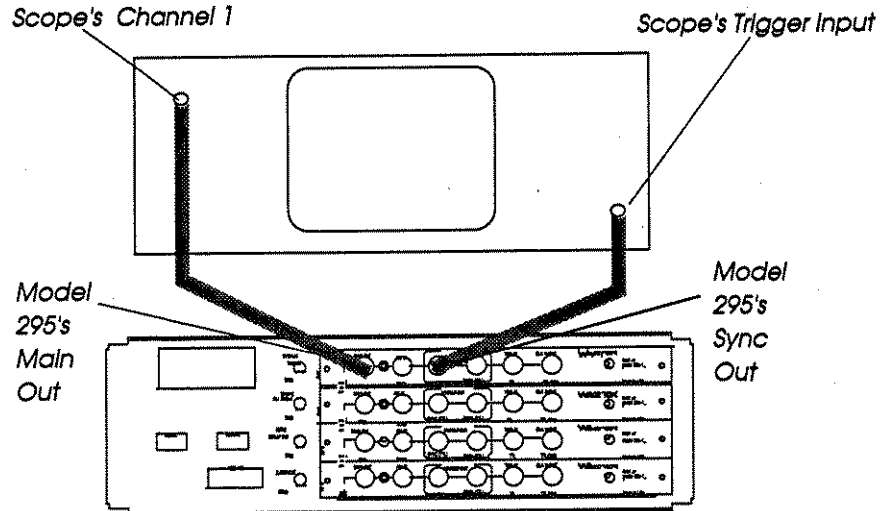

Figure 2-10. Model 295 to Scope Interconnections

4. **Main Out and Sync Out Check.** Initially the Main Out is turned off and the Sync Out is turned on. Connect the Arb Channel to the scope as described in step 3.

Turn on the Main Out by pointing the mouse pointer at Output OFF and clicking the left mouse button. The output toggles ON. See figure 2-11. To select items on the screen without the mouse, refer to section 3, "Using the Mouse and Keypad", and "Selecting Items Using the Front Panel Keys".

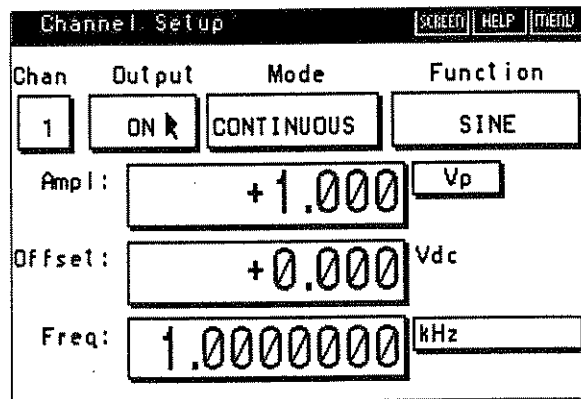

Figure 2-11. Output ON

You may turn on or off the Sync Out by pointing the mouse pointer at the MENU "button" and clicking the left mouse button. From the pop-up list select Sync Marker by pressing the "soft" key next to Sync Marker. Point the mouse pointer at ON in the Sync Marker box and clicking the left mouse button. Select DONE to return to the Channel Setup screen.

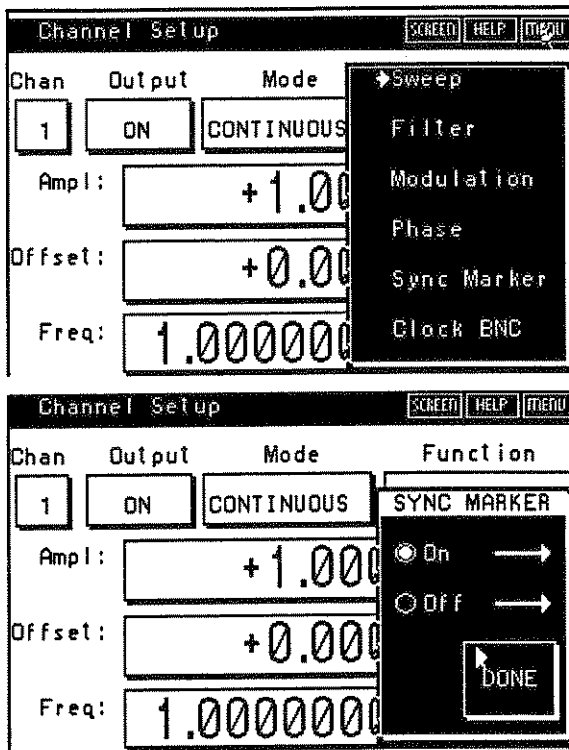

Figure 2-12. Sync Marker ON

Adjust the scope (time base and amplitude) to display a 1kHz, 1Vp, continuous, sine wave.

5. **Frequency Check.** Connect the Arb Channel to the scope as described in step 3. Vary the frequency by placing the mouse pointer in the Freq: field and clicking the left mouse button. Next, place the pointer on the most significant digit, 1, and click the left mouse button several times. See figure 2-13. Observe the increasing frequency on the scope.

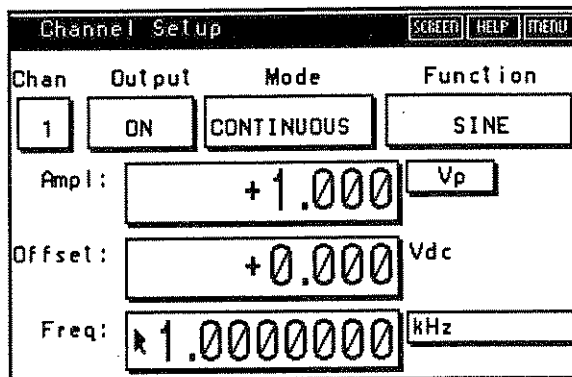

Figure 2-13. Changing Frequency

With the pointer still on the most significant digit, press the right mouse button once. Next press the left mouse button. Observe the decreasing frequency on the scope. Return the frequency back to 1.000000 kHz.

6. **Amplitude Check.** Connect the Arb Channel to the scope as described in step 3. Change the amplitude by placing the mouse pointer

in the Ampl: field and clicking the left mouse button. Next, place the cursor on the most significant digit, 1, and click the left mouse button several times. Observe the increasing amplitude on the scope.

With the pointer still on the most significant digit, press the right mouse button once. Then press the left mouse button. Observe the amplitude decreasing on the scope. Return the amplitude back to 1.000 Vp. See figure 2-14.

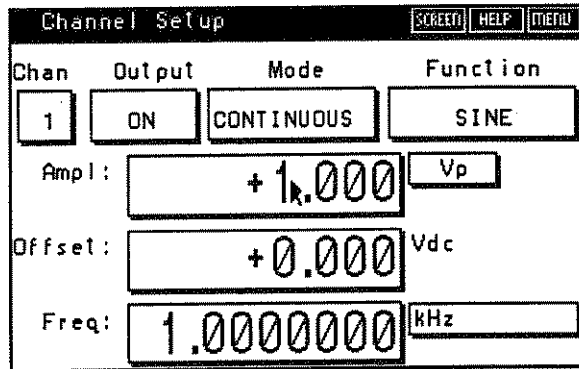

Figure 2-14. Changing Amplitude

7. **Function Check.** Connect the Arb Channel to the scope as described in step 3. To select functions, place the mouse pointer in the Function field and click the left mouse button. Select the square wave from the pop-up list with the left mouse button or by pressing the "soft" key next to SQUARE. See Figure 2-15. Observe the square wave on the scope.

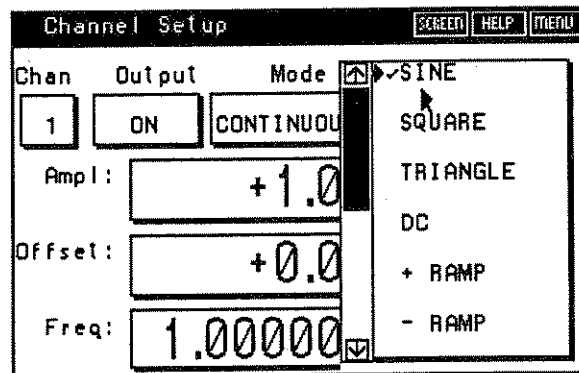

Figure 2-15. Changing Functions

To select an Arbitrary Waveform, again point and click the mouse at the Function field. Place the mouse pointer on the "down" arrow in the pop-up list and click the left mouse button until "WAVEFORMS..." appears. Select WAVEFORMS ... using the mouse or the "soft" key next to it.

The next screen, the Waveform Catalog, displays all the stored arbitrary waveforms, if any, in the selected source (initially battery backed RAM). See figure 2-16. Select a Waveform (.WFM) by placing the mouse pointer in the list and clicking the left mouse button. Select DONE to activate the Waveform. Observe the waveform on the scope.

If the catalog is empty, you can create a Waveform or choose to move on the next step. To create a Waveform, refer to the example used in section 3, "Using Waveforms, Creating a New Waveform".

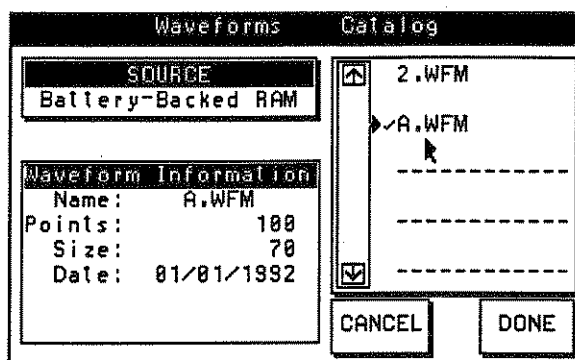

Figure 2-16. Waveform Catalog

Select the Function field once more. Select SINE from the list.

8. **Mode Check.** Connect the Arb Channel to the scope as described in step 3. To change the unit's operating Mode, place the mouse pointer in the Mode field and click the left mouse button. Select the triggered mode from the pop-up list by pressing the "soft" key next to TRIGGERED. See figure 2-17. In order to see the triggered sine wave on the scope, change the frequency to 10 kHz by selecting the Freq: field and using the keypad enter 1 EXPONENT 4 ENTER. Adjust the scope and observe a 10 kHz sine wave, triggered at a 1ms rate on the scope. The default trigger source is the Model 295 internal trigger generator.

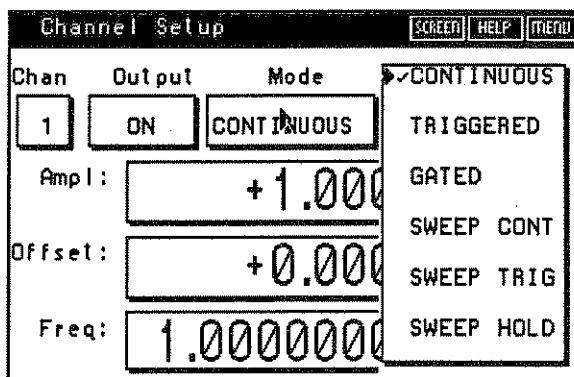

Figure 2-17. Change Modes

Arb Channel's TRIG IN BNC. To trigger the Arb Channel 1 from an external trigger source, press the front panel TRIGGER key. Place the mouse pointer on the START field on the Trigger Setup screen and click the left mouse button. This displays a list of trigger sources. Place the mouse pointer on "Channel's External Trig In BNC" and click the left mouse button which selects the Arb Channel external TRIG IN as the trigger source.

Connect the signal source (properly terminated) to Arb Channel 1 TRIG IN connector. Set the signal source for a 1kHz, TTL square wave. Connect the Arb Channel to the scope as described in step 3, but trigger the scope using the external signal source. Observe on the scope a 10 kHz sine wave triggered at a 1kHz rate.

Press the CHANNEL key to return to the Channel Setup screen.

Continuous Sweep Mode and Horizontal Sweep Out Check. Select the Channel Setup screen. Place the mouse pointer in the Mode field and click the left mouse button. Select Sweep Continuous from the pop-up list by pressing the "soft" key next to SWEEP CONT. See figure 2-18. Connect the Arb Channel to the scope as described in step 3, but connect the Model 295 Horizontal Sweep Output to channel 2 on the scope. Display both channels on the scope.

Observe on the scope:

Channel 1 displays a linearly swept sine wave whose frequency varies between 1kHz and 10 kHz at a 1s rate.

Channel 2 displays a linear ramp proportional to the sweep's frequency change.

Disconnect the Horizontal Sweep Out cable.

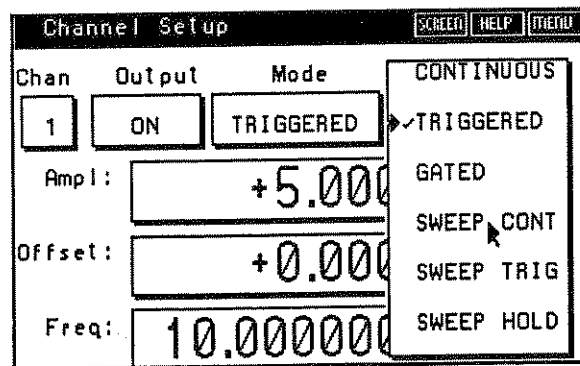

Figure 2-18. Sweep Mode

9. **Modulation Check.** Select the Mode field and choose CONTINUOUS. Select the Amplitude field, and change to 5Vp (5 ENTER via keypad). Move the mouse pointer to the MENU button and click the left mouse button. Press the "soft" key next to MODULATION. See figure 2-19. Click on AM in the dialog box. End by selecting DONE.

Set the external signal source for 1kHz, 1Vp-p sine wave. Connect the output from the signal source to the Arb Channel's AM IN connector. Connect the Arb Channel to the scope as described in step 3, but sync the scope to the signal source.

Observe on the scope a 10 kHz sine wave amplitude modulated (approximately 100%) by a 1kHz sine wave.

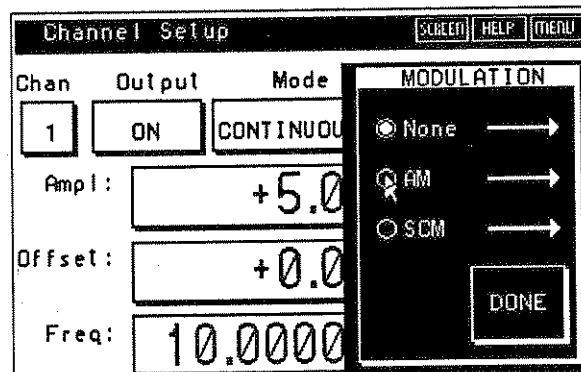

Figure 2-19. Modulation

10. **Clock Out Check.** Move the mouse pointer to the MENU button and click the left mouse button. Press the "soft" key next to CLOCK BNC. Select Internal, Clock Output ON from the list using the "soft" keys. See figure 2-20. Connect the Arb Channel's CLK IN/OUT to channel 1 on the scope; be sure to terminate the CLK OUT cable with a 50Ω termination. Observe on the scope a 50 MHz TTL signal, which is the standard waveform's sample frequency.

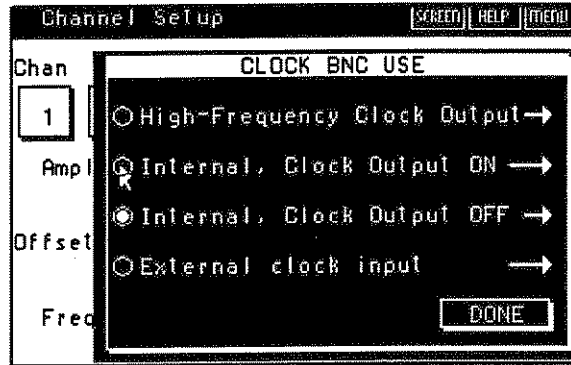

Figure 2-20. Clock Out

11. **Ref Out Check.** Press the INSTRUMENT key on the front panel. Use the "soft" key to select 10 MHz Reference from the pop-up list. Place the mouse pointer on "Output" and click the left mouse button. Connect the Ref Out (rear panel of Model 295) to channel 1 on the scope. Observe a 10 MHz TTL signal on the scope.

This completes the functional test. Remove all cables and test equipment.

Routine Maintenance

No tools or equipment are required for routine maintenance. Cleaning materials required are listed below:

Description	National Stock Number
Cotton Cheesecloth	8305-00-267-3015 CCC-C-440, Type II, Class 2 (81349)
Mild Liquid Detergent	None

Routine maintenance for the Model 295 is limited to routine checks such as listed below;

- Cleaning,
- Dusting,
- Wiping,
- Checking for frayed cables,
- Storing items not in use,
- Covering unused receptacle,
- Checking for loose nuts, bolts, and screws.

Perform these routine checks anytime they need to be done.

OVERVIEW OF THE MODEL 295

The Model 295 contains up to four Arbitrary Waveform Generator Channels which can be used independently or synchronized together. Using an Arb Channel by itself, you can produce an assortment of standard functions. Plus, you can create and use Arbitrary Waveforms for special applications. In addition, you can link several Waveforms together to create a Sequence. The Model 295 allows you to trigger all functions including Waveforms and Sequences.

With multiple Arb Channels you can use the Model 295 as a phase generator. Or, you can mix channel outputs via analog summing.

Every Waveform and Sequence can be stored in battery backed RAM or to an optional disk drive. In addition, complete instrument configurations can be stored to RAM or disk.

Optionally, a model 295 chassis can be loaded with a High Voltage (summing) Channel and one to three Arb Channels. Refer to Appendix G for information on the High Voltage Option 007.

Using the Model 295

You have two ways of controlling the Model 295. First, you can use its graphical user interface and mouse to operate the unit. This section along with section 4 describes the graphical user interface. Second, you can send a command in the SCPI format to remotely control the Model 295. Section 5 describes the SCPI commands as well as the IEEE 488.2 common commands supported by the Model 295.

Appendix B of this manual contains a quick reference to the Model 295 screens and menus. Appendix C contains a quick reference to the SCPI commands used by the Model 295.

The following topics will be covered under this heading to give you an overview of Model 295 operations:

- Using the Mouse and Keypad
- Setting Up the Channel
- Creating and Editing Arb Waveforms
- Creating and Editing Sequences

Help Menu

The model 295 user interface includes an extensive set of Help Screens

which can be used for reference in addition to this manual. To access the Help Screens, simply select the Help Icon which is located at the top, right of the Display (for most screens).

Initial Setup

Before operating the Model 295, you must connect it to the correct power source. Make sure the fuse in the instrument matches the fuse required for your primary power source's voltage. See Section 2, Preparation for Use, Fuse Selection/Replacement. Also, be sure the instrument's specified line voltage matches your primary power source. Using the supplied power cord, connect the Model 295 to the primary power source.

Using the correct cables and terminations, connect the Model 295 to a receiving device, such as an oscilloscope. Figure 3-1 illustrates a typical setup that connects the Model 295 Arb Channel's Main Out to channel 1 on the oscilloscope, and the Sync Out connects to the scope's trigger input. Cables from both outputs must be terminated with 50Ω. Figure 3-1 shows only Arb Channel 1 connected to the scope.

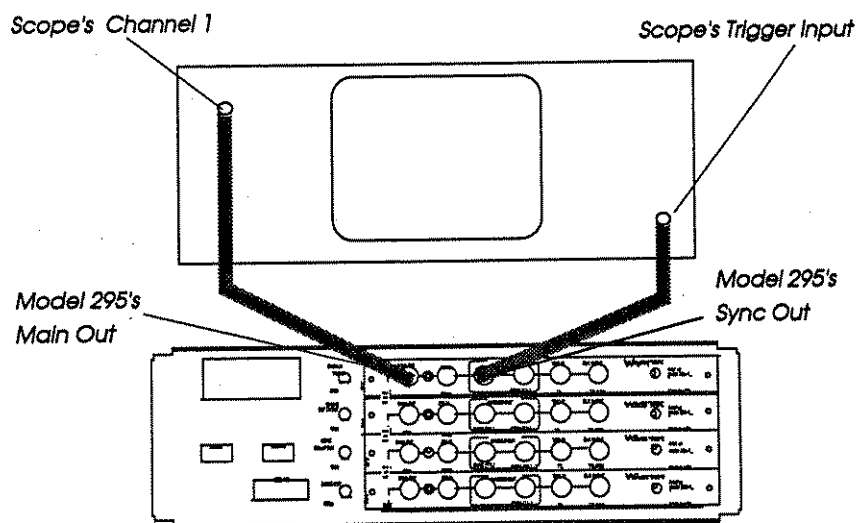

Figure 3-1. Model 295 to Scope Interconnection

When the Power is turned on, the Model 295 briefly displays its start up screen, figure 3-2. During power up, the Model 295 performs Self-Test. Immediately after the start up screen, the Channel Setup screen appears.

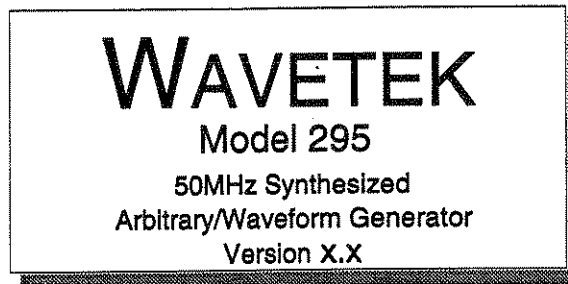

Figure 3-2. Model 295 Start-up Screen

The Main Screens

The Model 295 uses six main screens from which you can control the instrument:

The Channel Setup Screen,
Waveform Management Screen,
Sequence Management Screen,
Utilities Screen,
Instrument Screen,
Trigger Setup Screen.

The group of keys used to select the six main screens are located on the front panel below the "arrow" keys. Pressing one of these keys brings up its main screen. Each main screen has its own MENU. The Menu Box for the current screen is alternately displayed or hidden by pressing the dark gray *menu key* at the top-right corner of the Liquid-Crystal Display (LCD). The Menu Box lists menu choices, which may be selected as follows (1 to 3) below. Selecting a menu choice may cause a sub-screen to be displayed.

1. *Use the mouse* - move the mouse cursor over the item and press the left mouse button.
2. *Use the arrow keys* - press the arrow keys until the item is blinking, then press the SELECT key.
3. *Use the dark gray Menu Select keys* - if the item is in a menu, simply press the dark gray key adjacent to the item.

For example, either cycling power to the unit or pressing the CHANNEL key brings up the Channel Setup screen (shown on the following page with the Menu Box hidden). You can "show" the Menu Box by pressing the Menu Key at the upper-right of the display and then see how the menu choices line up with the dark gray keys. The top choice should be blinking. "Hide" the Menu Box for now by pressing the menu key once more. The channel number field in the screen (Channel 1 by default) should be blinking. Each field in the screen with a shaded box drawn around it can be selected (1 to 3 above) and have its value modified. To change a selected value:

1. *Use the numeric keypad* - key in a new number, and when you have it the way you want it, press the ENTER key.
2. *Use the arrow keys* - the Up/Down arrows will increment/decrement a blinking digit. When it's changed to the value you want, *deselect* the blinking digit (with the mouse or SELECT key).

3. *Use the mouse* - the left/right mouse buttons increment/decrement a blinking digit.
4. *Pick from a list* - for example select "Mode" so that "CONTINUOUS" is blinking, press SELECT to open the Mode Menu Box, and see the list of possible generator modes for the ARB. The mouse or the dark gray menu selection keys may be used to select from the list.
5. *Check a button* - use the arrows and SELECT key or the mouse and the mouse's left button to check selectable boxes or round buttons.

The following figures illustrate each screen and provide a brief description of each screen. For more details on each screen refer to section 4 of this manual.

Chan	Output	Mode	Function
1	ON	CONTINUOUS	SINE

Ampl: +5.000 Vp

Offset: +0.000 Vdc

Freq: 10.000000 kHz

Channel Setup Screen

Use the Channel Setup Screen to program an individual ARB Channel.

Waveforms Management

- Active
- Load
- Edit
- Copy
- Delete
- New

Waveforms Management Screen

Use the Waveforms Management Screen for user-defined waveforms.

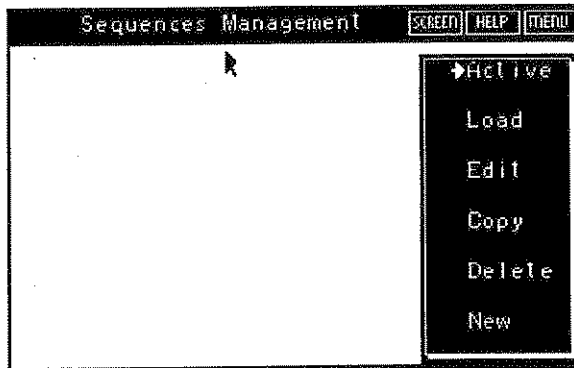

Sequences Management Screen

Use the Sequences Management Screen for linking multiple waveforms together.

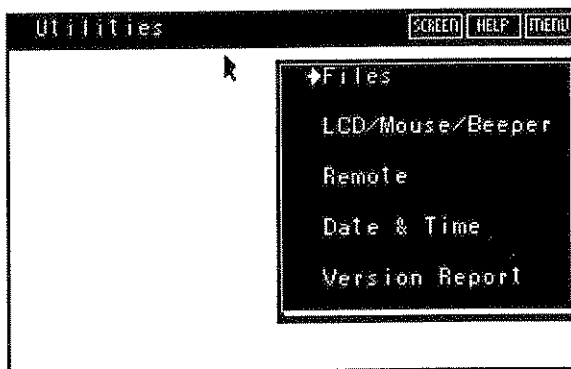

Utilities Screen

Use the Utilities Screen to review files, set preferences, set up the remote interfaces, set date and time, and check the firmware version.

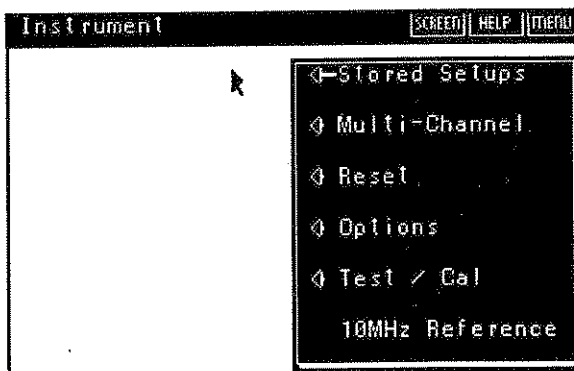

Instrument Screen

Use the Instrument Screen to access general functions, Analog Summing, Independent or Master/Slave channel relationships, and the Options.

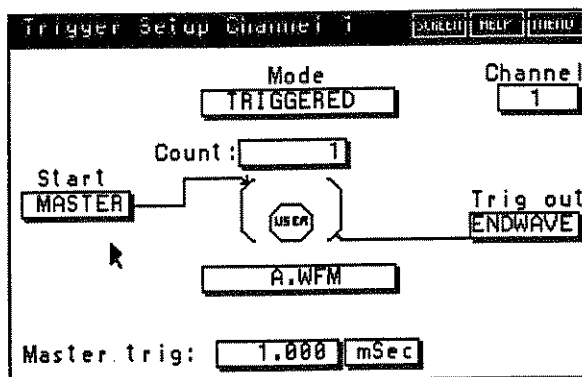

Trigger Setup Screen

Use the Trigger Setup Screen to select the trigger source and to adjust trigger slope and level.

SCREEN ITEMS

The Channel Setup screen (figure 3-3) provides an excellent example of the different types of Model 295 screen items: *Selector Fields*, *Edit Fields*, *Boolean Fields*, and *Dialog Boxes*. You can change any item enclosed by a "Shaded Box". You can access any item using either the mouse or keypad.

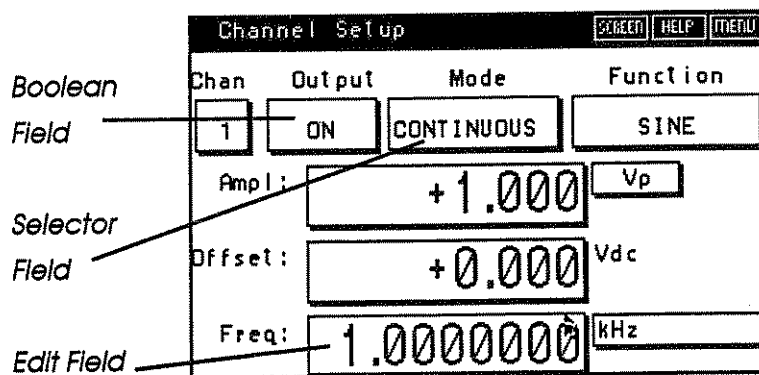

Figure 3-3. Sample Screen

Selector Fields

Selecting these Fields brings up a scroll list of all choices for that field. For example, the "Function" field allows selection of Sine, Triangle, Waveform, Sequence, etc. Other examples of Selector Fields on the Channel Setup screen are "Mode" and "Chan".

Boolean Fields

Some items when selected toggle between two states, usually "On" or "Off". The "Output" field is a Boolean Field which toggles between on and off.

Edit Fields

Selecting an Edit field allows changing of values or data. For example, the "Freq:" field allows the frequency of the function to be changed. Other

examples of Edit Fields are "Ampl:" and "Offset:".

Dialog Boxes

A dialog box contains "radio buttons" or check boxes from which you must make choices. The "Filter" menu, for example, under the Channel Setup's Menu "button" selects output filters by selecting radio buttons.

MENU Items

Selecting the MENU button field (at the upper right corner of most display screens) or the adjacent menu key displays an additional list of items related to the screen. Many of these items consist of additional screens which appears to the left of the list (when the item has a "left arrow").

Flashing Items

A flashing item illustrates any item that can currently be selected by pressing the SELECT key. For example, selecting the SCREEN button field causes it to flash. Then pressing SELECT brings up a list of all the main screens. Picking an item from this menu is the same as pressing the equivalent front panel key.

USING THE MOUSE AND KEYPAD

This paragraph describes using the mouse and front panel keys to step through the screens. For more information on the menus used in this example, refer to section 4.

Selecting Items Using a Mouse

To pick an item with a mouse, move the mouse pointer (the arrow) to the item and click the mouse's left button.

Picking a Selector field flashes the field, reverse video, and displays a listing of available choices. For example, select the "Function" field in the Channel Setup screen. If a menu contains more than six items, there will be a box for moving through the list; see figure 3-4. Use the mouse pointer to pull the slider box up or down. Also, you can point and click using the mouse at the arrow on the top and bottom of the slider box to move the list. Lists with six or fewer items will not have a slider box. The pointer (>) identifies items selectable using the SELECT key. A check mark (✓) identifies the currently selected or *active* item. To select another item, move the mouse pointer to the new item and click the mouse's left button. The new item flashes and the Model 295 returns to the original screen.

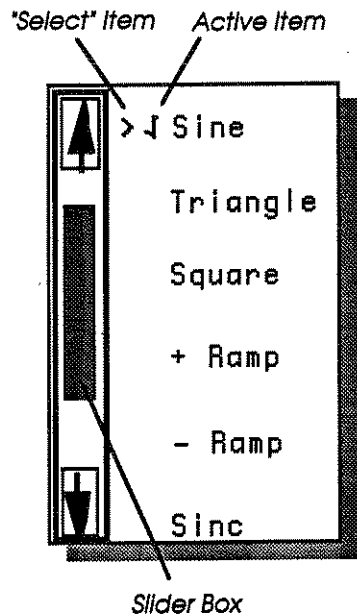

Figure 3-4. Pop Up Menu (Function)

Selecting an Edit field flashes the field. Use the mouse to point to one of the digits. Press the left mouse button to change the digit.

Clicking the mouse's left button now changes the value. You can use the left mouse button to increment or decrement the value. To switch from increment to decrement, press the mouse's right button.

NOTE: When doing Scope Edit (Waveforms), you cannot use the right mouse button to switch between increment and decrement. See Section 4, "Scope Edit Screen, Cursor Address and Data" for more information.

Figure 3-5 illustrates the Amplitude field from the Channel Setup screen.

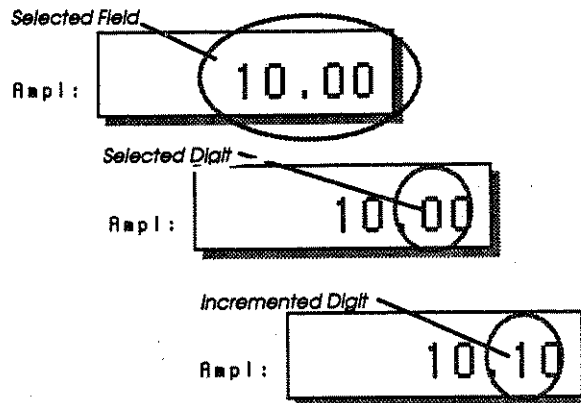

Figure 3-5. Selecting and Changing Values (Ampl selected)

Selecting Items Using the Front Panel Keys

You also can change fields via the front panel keys. To select a field, press the "arrow" keys until the desired field blinks. The "down arrow" tends to move down through the fields while the "up arrow" does the opposite. The "left arrow" and the "right arrow" move to the left and right fields respectively. See figure 3-6.

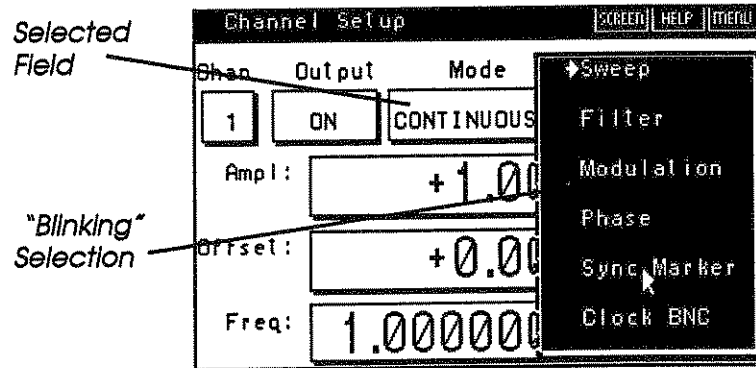

Figure 3-6. Selector Field

If a Selector field is picked, press the SELECT key to display a list of choices; see figure 3-7. To select an item from the pop-up menu, press the "soft" key next to the menu item. Also, you can use the arrow keys to move the cursor to the item you want and press the ENTER key to select.

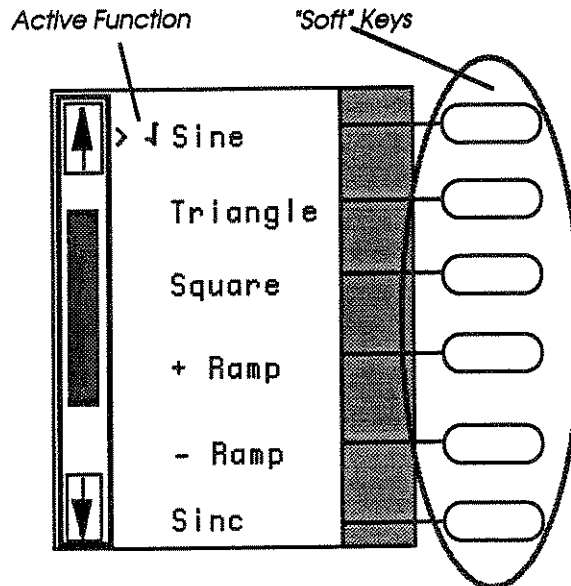

Figure 3-7. Pop Up Menu (Function) with soft keys

If the list has more than six items, a scroll box appears with the list. Move the list up or down by pressing the up or down arrow keys. A pointer (>) identifies items that can be selected using the SELECT key.

Select a menu item by pressing the "soft" key next to it. The item flashes and the Model 295 returns to the original screen. A check mark (✓) identifies the currently selected or *active* item.

If an Edit field is picked, pressing the SELECT key causes the value to blink a single character. Use the left and right "arrow" keys to move the blinking digit to the left or right. Next, press the up "arrow" or down "arrow" to increment or decrement the value. As the value increments from 9 to 0, it carries to the next decade or subtracts from the previous decade. Note that the up and down arrows consider the "sign" of the value when incrementing or decrementing. The lowest value is the most "negative" value for a field. The highest value is the most positive. For example, if a field displays the value "-1.451" with the "5" blinking, and you press the up arrow, the value will "increment" to "-1.441", the next positive value of the blinking digit. The hardware controlled by the Edit field is updated after each digit change.

Press the SELECT key again when finished.

Using the Keypad to Change Values

When you want to change values in an Edit field, such as the Freq: field, you can use the numeric keypad. Select the field using either the mouse or arrow keys; the field blinks (see figure 3-8).

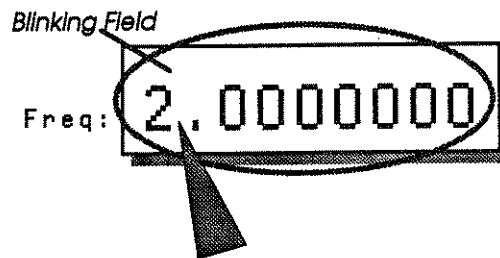

Figure 3-8. Selected Edit Field

Enter the new value using the numeric keypad. You can enter values in three basic formats: Integer, floating point, and exponential. Press the ENTER key when finished to change the value. The hardware controlled by the Edit field is updated only after ENTER is pressed.

Changing a Value

Press the CLEAR key to erase the entire value. Or, use the BSP (backspace) key while using the keypad to erase digits to left of the cursor, one digit at a time. In either case, you can then use the numeric keypad to re-enter the value.

Using Both the Mouse and Keypad

You can combine both the mouse and keypad operations when making changes to fields. For example, you may find it easier to select Edit fields, such as Offset, using the mouse, and then change the value using the keypad.

ENTERING NAMES

Many operations requires you to enter names. For example, you must name waveforms, sequences, and configurations. The Model 295 uses these names to identify them in catalogs. For the most part all name screens function the same except for a few minor items. Figure 3-9 illustrates a typical name screen.

Using The Mouse To Enter Names

The mouse is the easiest way to enter the name. Simply point the mouse pointer at a character in the set and click the left mouse button. The new character appears in the Edit box.

To backspace through a character using the mouse, point the mouse pointer at backspace character (⇐) and click the left mouse button. The CLEAR and BSP keys can also be used to delete a name from the edit box.

For example, to enter the name "SCM", point the mouse pointer at "S", "C", and "M" while clicking the left mouse button at each character.

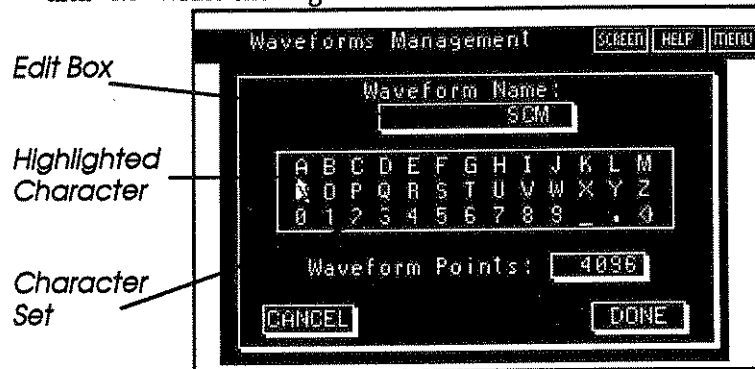

Figure 3-9. Name Screen

Using the Arrow Keys to Enter Names

As with all screens, you can use the arrow keys to move around the screen. When the name screen first appears, the character "A" is highlighted (reverse video). Once the desired character is highlighted, press the ENTER key or the SELECT key to accept the character.

Pressing the right arrow key moves the cursor to the right. At the end of the line, the cursor wraps back to left end of the same line.

Pressing the left arrow key moves the cursor to the left. At the end of the line, the cursor wraps to right end of the same line.

Pressing the up arrow key moves the cursor up one line. From the top line of the character set, the cursor moves to the Edit box.

Pressing the down arrow key moves the cursor down one line. From the last line of the character set, the cursor moves to the DONE button.

For example, to enter the name "SCM", press the down arrow key once to highlight "N" and press the right arrow key until "S" is highlighted; press the ENTER key. Next press the up arrow key which highlights "F" and press the left arrow key until "C" is highlighted; press the ENTER key. Press the left arrow key until "M" is highlighted (notice the cursor wraps from first to last characters on the same line); press the ENTER key. Press the down arrow key until DONE is highlighted. Press the SELECT key to accept the new name.

There is one final way to enter a name. If you move to the Edit box, and use the SELECT key or left mouse button to select the field, you can use the arrow keys to enter the name. LEFT and RIGHT keys move through the already-entered characters. When you go beyond the last character in either direction, spaces are added to the name. The UP and DOWN keys scroll through the available characters at the currently blinking character position. Press ENTER when done. Any leading or trailing spaces are automatically removed at that time.

GETTING HELP

Major screens in the Model 295 contain on-screen help. Help screens explain the screen, as well as, how to use the screen. To read a Help screen, select the HELP "button". Every time Help is selected after the first time, the Model 295 displays a help screen relative to the current screen. Figure 3-10 illustrates the help screen for the Utility item: Viewing Angle.

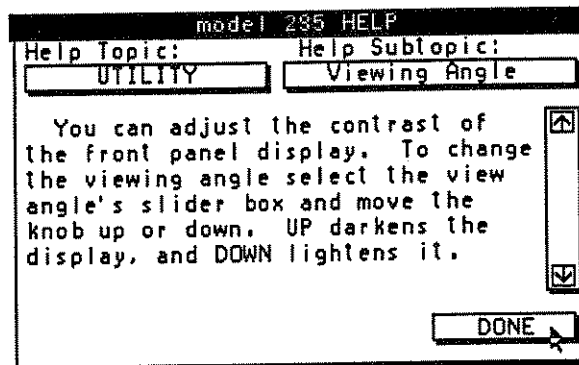

Figure 3-10. Help Screen

If you select the Help Topic selection field, a list of the major help topics appears. Topics include general information and help on each of the six main front panel screens (Channel Setup, Waveforms, Sequence, Trigger, Instrument, and Utilities). The Help Subtopic selection field lists available

areas of help for the currently displayed topic. For additional text, use the "arrows" in the slider box to scroll through text. The Topic and the selected Subtopic reflects the currently selected field and screen.

Selecting DONE returns you to the screen from which you invoked help.

ERROR MESSAGES

When the Model 295 detects an error in an operation, it displays a dialog box describing the problem. Refer to Appendix E for information on many common messages. There are several types of error messages:

An INFORMATION message informs you of a condition you should know about, which does not effect instrument operation. For instance, if you attempt to store a system setup with no channels installed, you will get an INFORMATION dialog and the request will be ignored.

A WARNING message tells you that the operation you are performing may not give you the result you expect. You would get a WARNING when you save a setup using a setup name that already exists.

An ****ERROR**** message occurs if you attempt an illegal operation, such as attempting to set the amplitude value outside the range supported by the instrument.

Finally, PARAMETER CONFLICT messages warn you when you set up the instrument into a state that is physically possible, but is outside of a specified range. For example, you can set the triangle function frequency above 2 MHz, but the result is not specified.

USING THE CHANNEL SETUP SCREEN

The Channel Setup screen controls individual Arb Channel boards. From this screen you can set up the Model 295 to perform numerous operations. For example, from this screen select existing functions (standard, Waveforms, or Sequences) or select the mode (continuous, triggered, gated, or sweep). Select one of the modulation modes (amplitude or suppressed carrier modulation) to generate amplitude modulated signals. Or, use the Channel Setup screen to operate the Arb Channel as a sweep generator.

Channel Setup Screen Basics

The previous paragraphs, *Using the Mouse and Keypad*, introduced some of the Channel Setup menus. Figure 3-11 summarizes the Channel Setup screen.

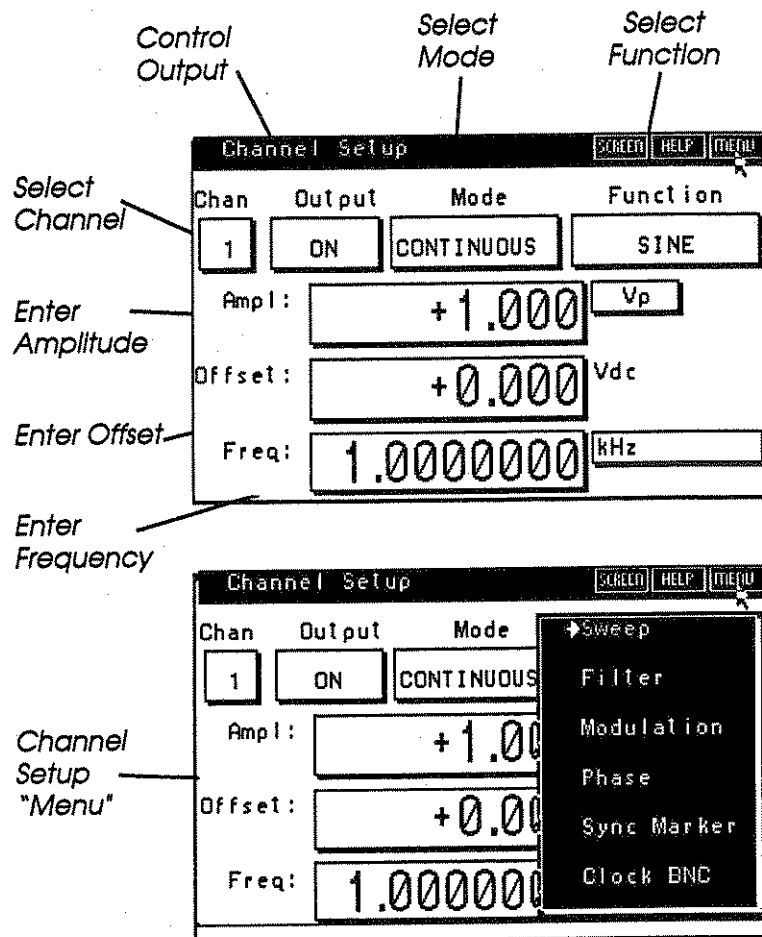

Figure 3-11. Channel Setup Screens

The following example steps you through a simple Arb Channel setup. Before continuing, connect the Model 295 to the scope as described in *Initial Setup*. This example uses the mouse to select fields and menu items and the keypad to enter new values.

Select the Channel

Select an Arb Channel by pointing the cursor at the Chan field and pressing the left mouse button. This displays the Arb Channel list. Select the channel you want to use using the mouse or "soft" keys. When the Channel Select field is blinking, you can also select the channel by entering the number (1 through 4) on the numeric keypad.

The Model 295 lists only those Arb Channels installed in the unit. The Model 295 does not display a channel list if the unit contains only one channel.

Turn On the Output

Turn on the Arb Channel's Main Output by pointing the mouse cursor at the Output field and pressing the left button. The output toggles between off and on. You must turn on the output to connect the signal to the external device. The Output selection effects only the selected Arb Channel.

Turn On the Sync Out

The Sync Out will be on when you power on the unit. If it is off, you may turn on the Sync Out (figure 3-12) by selecting the MENU button on the Channel Setup screen. From the pop-up menu, select SYNC MARKER. Select ON from the next screen. Select DONE to return to the Channel Setup screen.

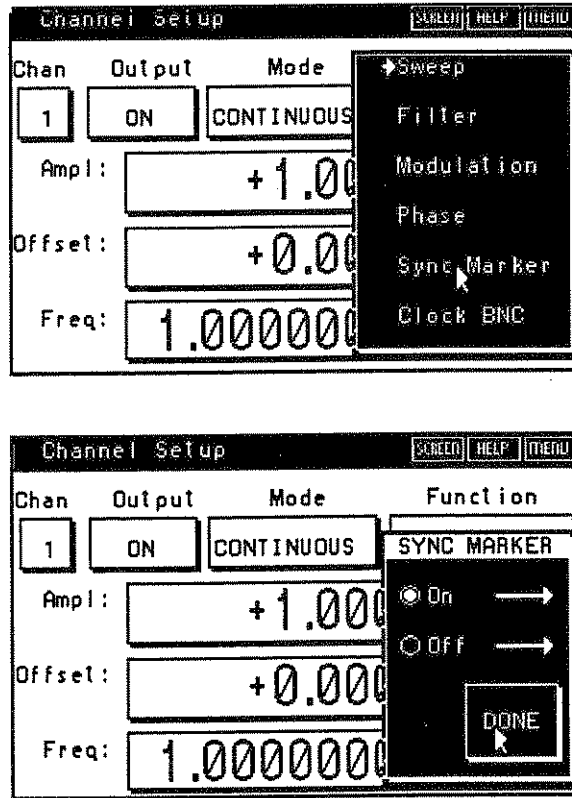

Figure 3-12. Sync Marker Screens

Select a Function

Select a function (figure 3-13) by placing the mouse pointer on the Function field and clicking the left mouse button. From the Function list select a function. For example, click on Triangle. Your scope displays a triangle.

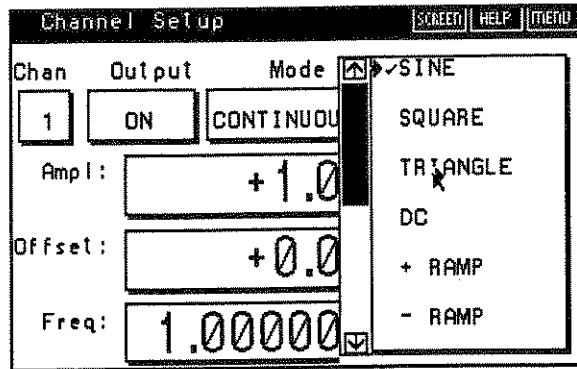

Figure 3-13. Selecting a Function

Change the Mode

Change the mode (figure 3-14) by placing the mouse pointer on the Mode field and clicking the left mouse button. The Mode list displays continuous, triggered, gated, continuous sweep, triggered sweep, and triggered and hold sweep modes. For now, leave the continuous mode selected. The scope displays a 1 kHz, 1Vp, continuous triangle. Section 4 describes all modes in detail.

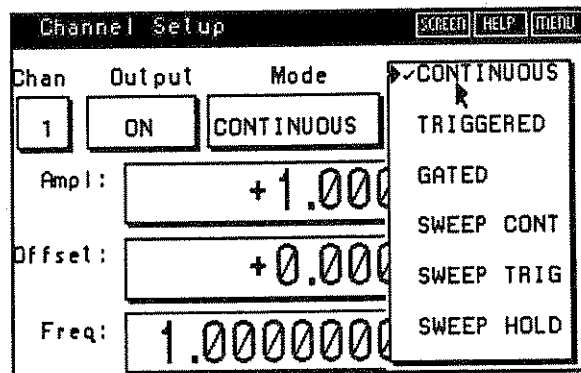

Figure 3-14. Selecting a Mode

Changing the Frequency

Change the frequency by placing the mouse pointer in the Freq field and pressing the mouse's left button (the frequency value blinks). See figure 3-15. You can select the time or frequency domain units of measure by selecting the units field to the right of the frequency number field.

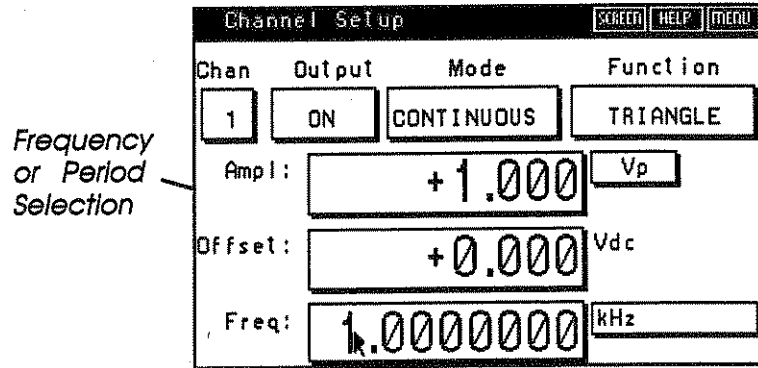
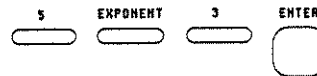

Figure 3-15. Changing a Value (Freq selected)

Next use the keypad to enter a new value. For example change the frequency to 5kHz by pressing:



You can enter 5kHz as 5000 (integer), 5000.0 (floating point), or 5 EXPO-NENT 3 (exponential). You must press the ENTER key to accept the new value. See figure 3-16.

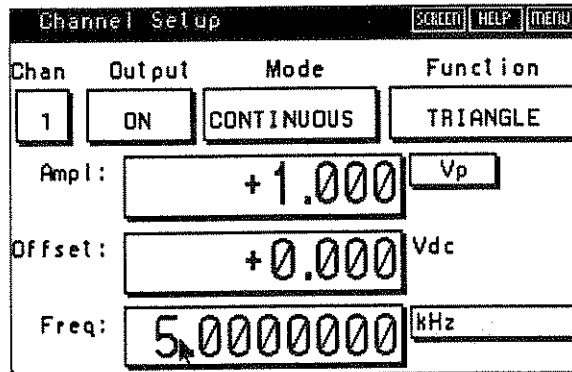

Figure 3-16. New Value

Changing the Amplitude

Change the amplitude by placing the mouse pointer in the Ampl: field. Then press the mouse's left button (the amplitude value blinks). See figure 3-17.

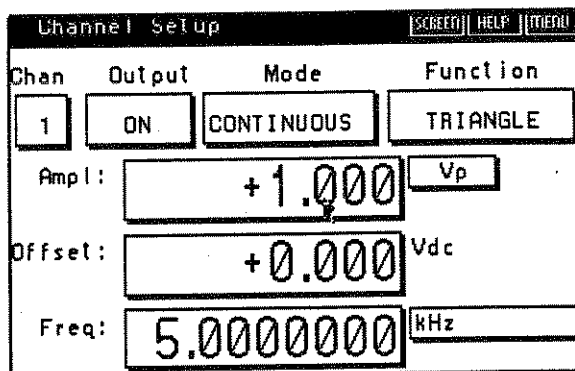
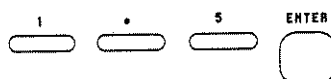

Figure 3-17. Changing a Value (Ampl selected)

Next use the keypad to enter a new value. For example change the amplitude to 1.5 Vp by pressing:



You also can change the amplitude's units of measure by placing the mouse pointer in the units of measure field (figure 3-18) and click the mouse button. This displays a units of measure list. Select another unit of measure. For example select Vrms; see figure 3-18. Notice that amplitude value changes to reflect the new unit of measure.

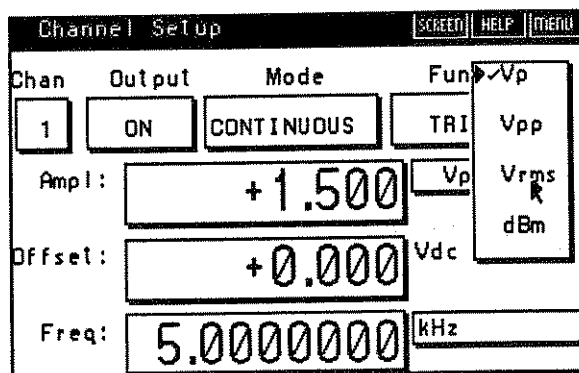

Figure 3-18. Selecting Vrms

Storing a Setup

After setting up Arb Channel 1 you can store the setup. When the Model 295 stores this configuration it stores all channels, as well as any instrument settings made.

To store this configuration, press the INSTRUMENT button and select STORED SETUPS from the menu. Select STORE from the next menu. See figure 3-19.

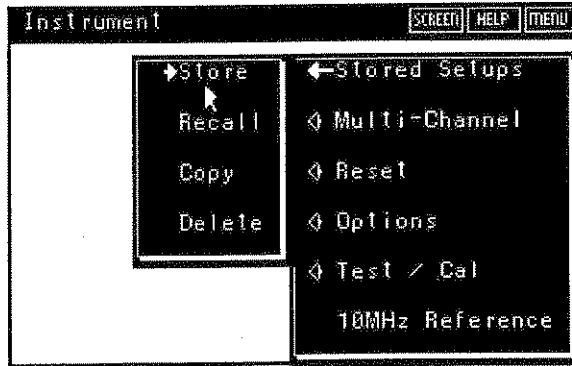

Figure 3-19. Selecting Stored Setup

Selecting STORE displays the Setup Name screen. See figure 3-20. To enter the name, simply point at a letter in the character set and click the left mouse button. For example, point at "Z" and click. Also see page 3-10, "Entering Names".

Also from this screen select the storage location. For example point the mouse at the radio button "Backup RAM" and click. Finally, point the mouse at DONE and click to store the setup.



Figure 3-20. Setup Name Screen

When finished the Model 295 tells you it saved the Setup; see figure 3-21. Using the mouse point to DONE and click the button.

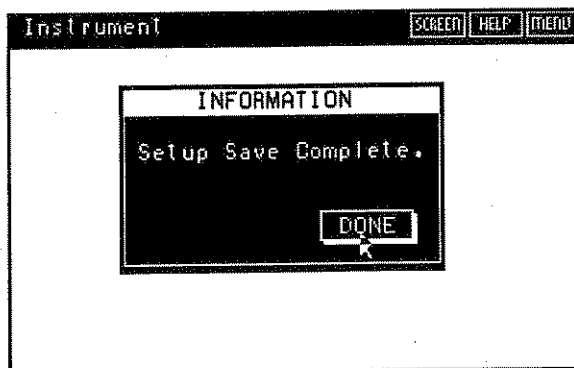

Figure 3-21. Information Screen

USING WAVEFORMS

This paragraph contains several examples on how to create, store, and edit an Arbitrary Waveform.

Creating an Arbitrary Waveform

The easiest way to understand Arbitrary Waveforms is by way of example. The following example steps you through the creation of a simple Arbitrary Waveform. This example uses the mouse to select fields and menu items and the keypad to enter new values. This example does not provide any more details than needed to create the waveform. For a detailed description of all the Waveform related screens, refer to section 4 in this manual. Also, Appendix B contains a quick reference for the Waveform screens. In addition to the manual, the Model 295 Help screens provide a good reference for waveform editing.

When finished with this example, you will have created a suppressed carrier waveform named "SCM".

Step 1 - Name the Waveform

To begin, first press the WAVEFORM button on the front panel. See figure 3-22. Select "New" from the menu.

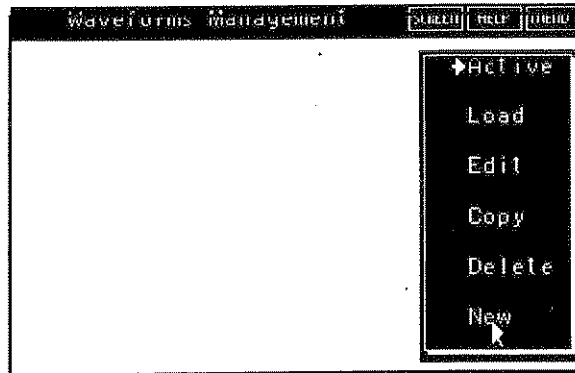

Figure 3-22. New Waveforms

The Waveform Name screen (see figure 3-23) appears after selecting "New". The first step in creating any Waveform is naming the waveform. Using the cursor, point and click at "S", "C", and "M" in that order. You can change the number of points (waveform size) in the waveform, but for this example leave the size at 4096 points. After entering the name "SCM", select DONE.

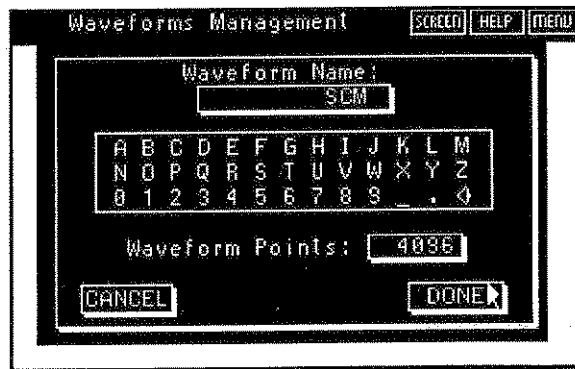

Figure 3-23. Naming the Waveform

Step 2 - Set Up Oscilloscope

The next screen (figure 3-24) describes the scope to Model 295 interconnections, as well as the scope's vertical and horizontal settings. Figure 3-25 illustrates the Model 295 to scope interconnections. If you do not set the scope's time base as listed on the Information screen, the Zoom tool (Section 4, "Scope Edit Screen, Other Editing Tools") will not function properly.

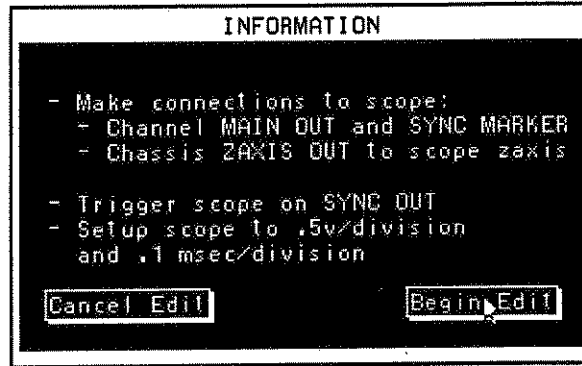

Figure 3-24. Scope Information Screen

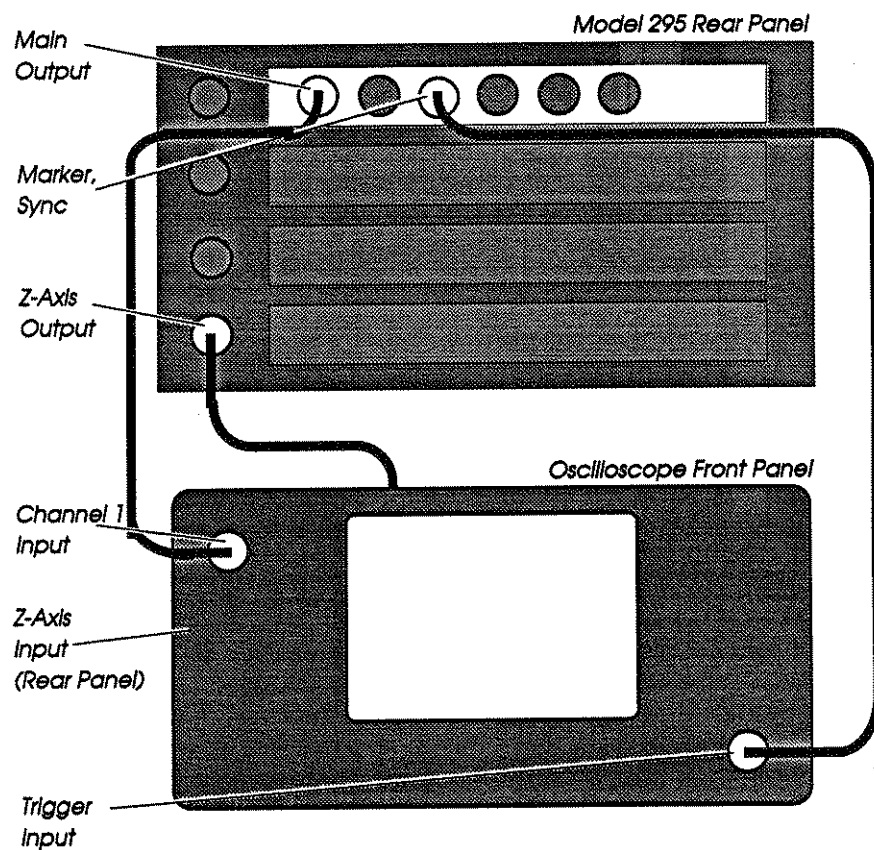

Figure 3-25. Scope Interconnections

Select "Begin Edit" to advance to the Waveform Scope Edit screen. See figure 3-26.

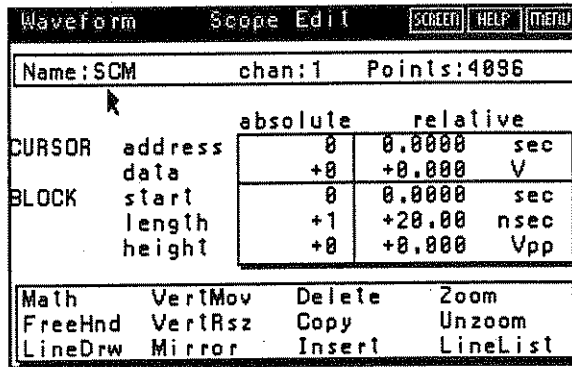

Figure 3-26. Waveform Scope Edit

Step 3 - Adjust Z-Axis Level to Oscilloscope

Before editing a Waveform, you should set up the Z-Axis level. Z-Axis modulates the intensity of the scope trace. Correctly setting the Z-Axis level marks the cursor position on the scope (usually a bright spot). Also, a properly set Z-Axis highlights a selected block of waveform points on the scope trace.

To set up the Z-Axis level, select the Menu "button" from the Waveform Scope Edit screen. See figure 3-27. Next point the mouse cursor at Z-AXIS and click the left button.

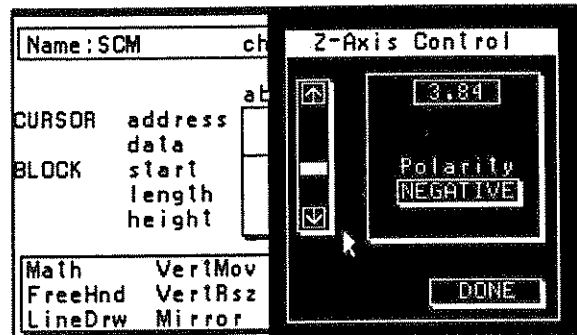

Figure 3-27. Z-Axis Setup

The following steps guide you through adjustment of Z-Axis level:

- Select Z-AXIS from the Scope Edit MENU "button."
- Select the proper polarity for your scope. Move the "Slider" up or down for the best intensity of the block; see figure 3-28.
- Select DONE when the intensity is correct. The screen returns to the Waveform Scope Edit screen. The Model 295 stores the Z-Axis setting (intensity range is $0 \pm 9.4V$).

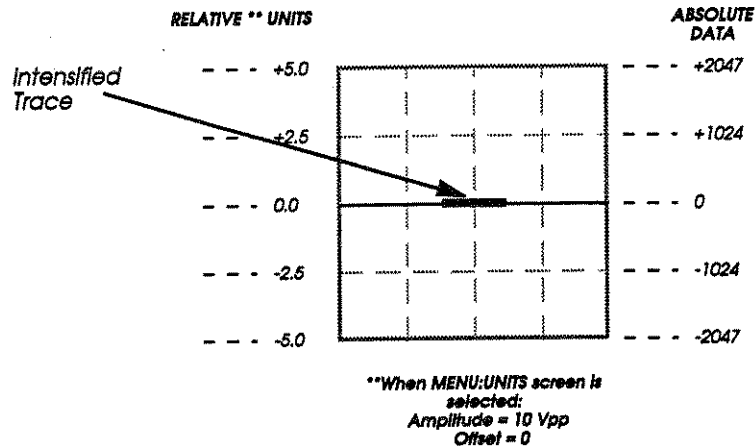

Figure 3-28. Correct Z-Axis Settings

Step 4 - Select a "Block" of Points in the Waveform

During Waveform Editing, there are two Cursors that are referred to. First is the LCD (mouse) cursor on the Model 295 display, and second is the "Waveform Cursor" on the oscilloscope. To toggle control between these two cursors, press the right mouse button or press the LCD/SCOPE key on the 295 front panel. Click the mouse's right button now to shift to "SCOPE" editing. Move the mouse to the left and to the right. Notice the cursor on the scope moves too. Place the cursor at the left edge of the trace. Then, double click the left mouse button. This will cause the entire set of points to become the selected "block" for editing. This is indicated by intensification of the scope trace and an update of the "BLOCK" values on the screen.

There are three different ways to select a block of points in the waveform. Refer to Section 4 'Scope Edit Screen Block Selection' or the Model 295 Help Screens for details.

After selecting the block, click the right mouse button to toggle control back to the LCD Cursor.

Step 5 - Use the Math Tool

On the Waveform Scope Edit screen move the LCD cursor to the Tools box. Point the cursor at "Math" and click the left mouse button. See figure 3-29.

Waveform		Scope Edit		SCREEN	HELP	MENU
Name: SCM		chan: 1	Points: 4096			
		absolute	relative			
CURSOR	address	392	7.8400	μsec		
	data	+0	+0.000	V		
BLOCK	start	0	0.0000	sec		
	length	+4096	+81.92	μsec		
	height	+0	+0.000	Vpp		
Math	VerMov	Delete	Zoom			
FreeHnd	VerRsz	Copy	Unzoom			
LineDrw	Mirror	Insert	LineList			

Figure 3-29. Selecting MATH

Selecting the Math tool, displays the EXPRESSION screen. Move the cursor

to the Function List field and click the left mouse button. See figure 3-30.

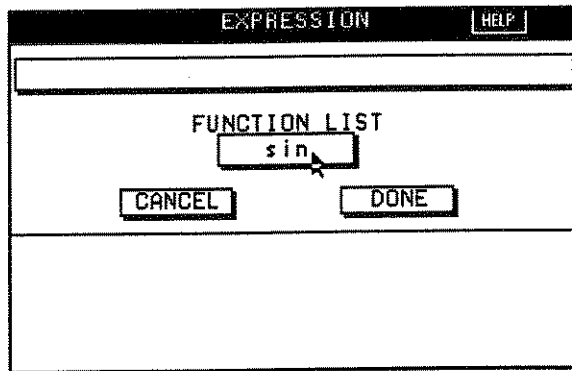

Figure 3-30. Initial Expression Screen

Select the Function List field to display the function list; see figure 3-31. Move the mouse cursor to "SIN" (sine function) and click the left mouse button. Also notice the other functions. For information on these math functions, refer to section 4, Waveforms, or use the Model 295 Help Menu.

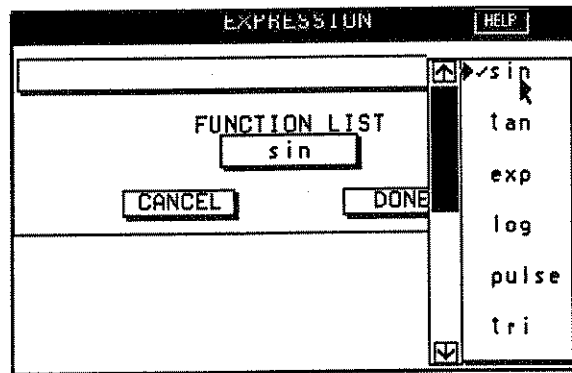

Figure 3-31. Function List

Selecting the SIN function returns Model 295 back to the Expression screen, but with "sin(t_" displayed in the expression field. See figure 3-32. Note the math syntax displayed after the function is selected.

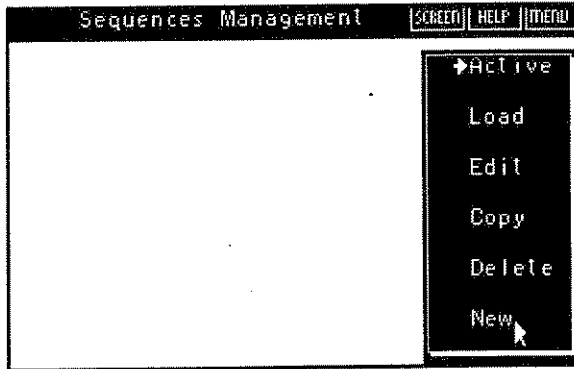

Figure 3-41. Creating a New Sequence

The Sequence Name screen (figure 3-42) appears. Name the sequence "TUTORIAL".

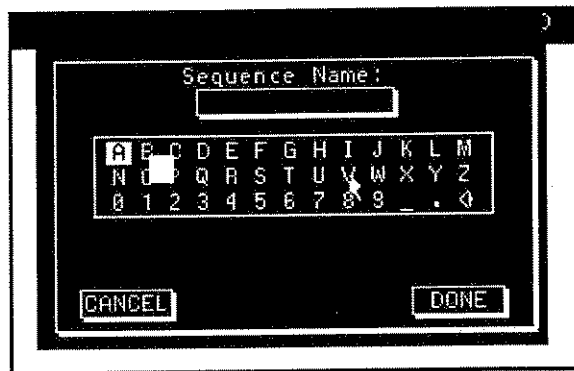

Figure 3-42. Naming the Sequence

Selecting DONE advances to the Sequence Edit screen; see figure 3-43.

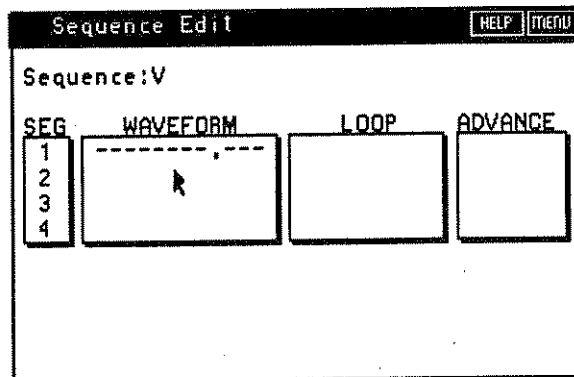

Figure 3-43. Sequence Edit

Step 3 - Set up the First Waveform In the Sequence

To select the first segment's waveform, place the mouse cursor in the

WAVEFORM field and click the left mouse button displaying the Waveforms Catalog. See figure 3-44.

From the Waveforms Catalog select the waveform, SCM.WFM, by placing the cursor on SCM.WFM and clicking the left mouse button. If SCM.WFM does not appear on the list, select Battery Backed RAM from the Source field.

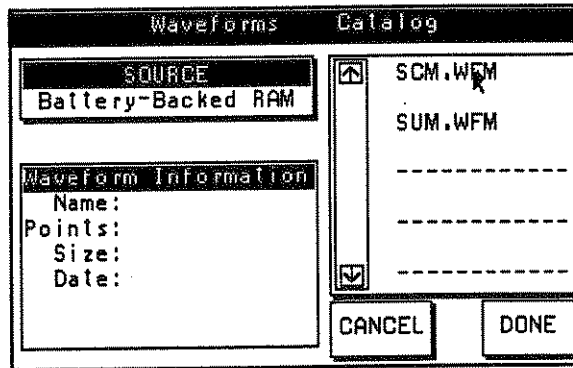

Figure 3-44. Waveforms Catalog

Select DONE to define SCM as the waveform for segment 1 and return to the Sequence Edit screen; see figure 3-45. Next select the Loop (Waveform repetition). Change the loop count by selecting LOOP from the Sequence Edit screen. This displays the Loop Waveform screen (figure 3-46).

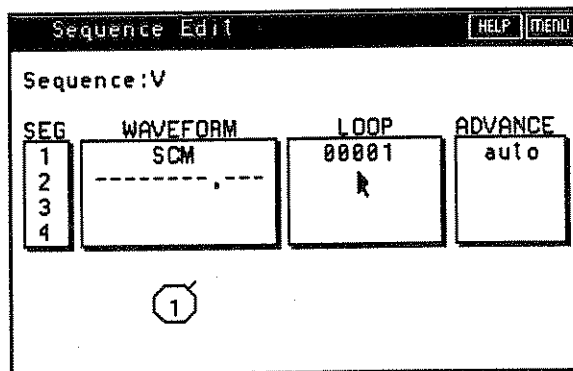

Figure 3-45. Sequence Edit

For this example, select CONTINUOUS from the Loop Waveform screen. Selecting DONE returns to the Sequence Edit screen.

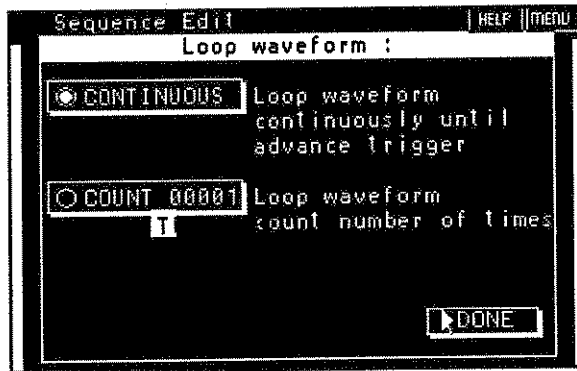

Figure 3-46. Loop Waveform Screen

Finally, select the ADVANCE field (figure 3-47) which displays the Advance to Next Waveform screen. Advance defines segment to segment advance conditions.

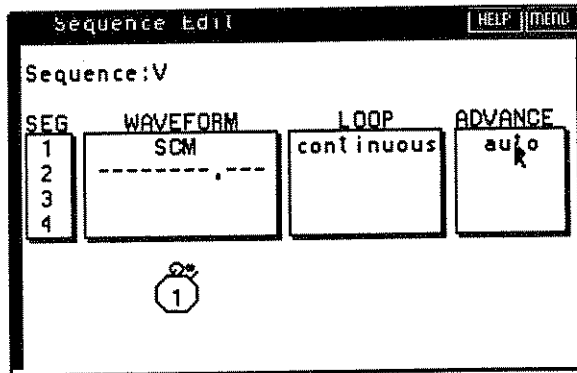

Figure 3-47. Sequence Edit Screen

From the Advance to Next Waveform screen, select ADVANCE TRIGGER, figure 3-48. This returns the Model 295 to the Sequence Edit screen.

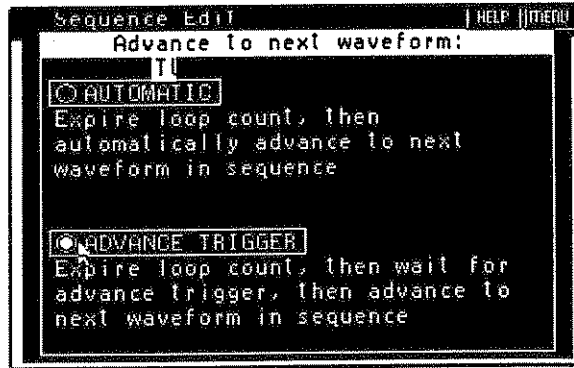

Figure 3-48. Advance to Next Waveform Screen

Step 4 - Set up the Second Waveform in the Sequence

To set up the second segment, place the mouse cursor in the WAVEFORM field and click the left mouse button. This displays the Waveforms Catalog. See figure 3-49.

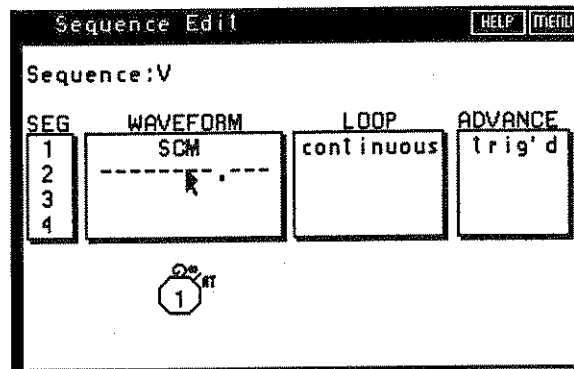

Figure 3-49. Sequence Edit

From the Waveforms Catalog select the waveform, SUM.WFM, by placing the mouse cursor on SUM.WFM and clicking the left button. If SUM.WFM does not appear on the list, select Battery Backed RAM from the Source field. See figure 3-50.

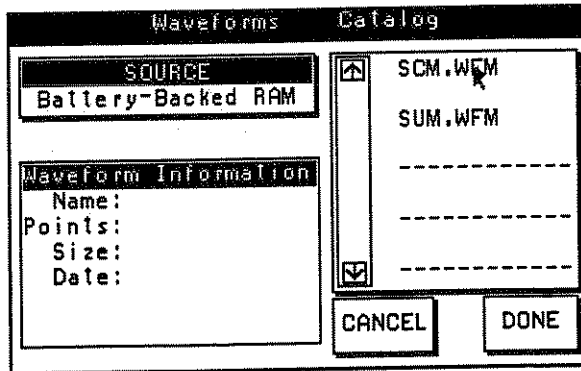

Figure 3-50. Waveforms Catalog

Select DONE to define SUM as the waveform for segment 2 and return to the Sequence Edit screen (figure 3-51). Next select the Loop (waveform repetition). Change the loop count by selecting the LOOP. This displays the Loop Waveform screen.

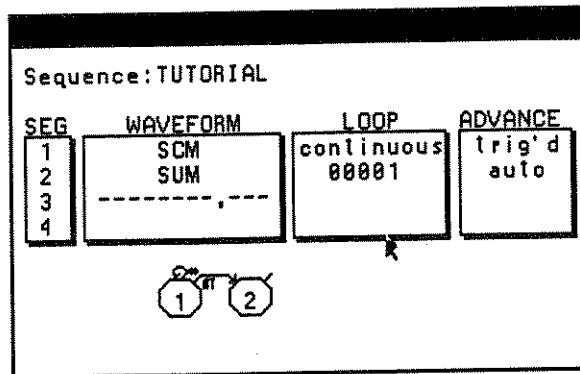

Figure 3-51. Sequence Edit

Select the COUNT "radio" button. Then select the count's value field (figure 3-52).

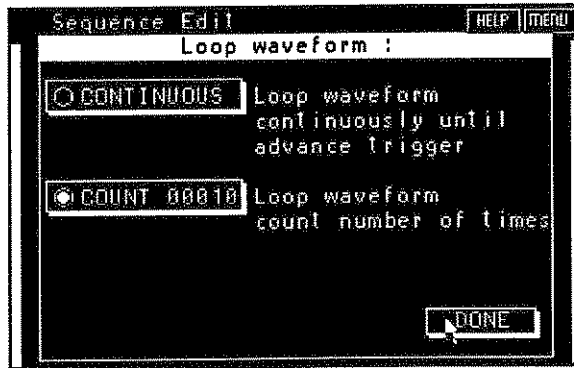

Figure 3-52. Loop Waveform

Using the numeric keypad, enter a count of 10; see below. Remember to press the ENTER key when finished.



Press the DONE key to accept the new count.

The Model 295 returns to the Sequence Edit screen; see figure 3-53. Notice the second segment's graphics. Leave segment 2 set as Auto Advance for this example.

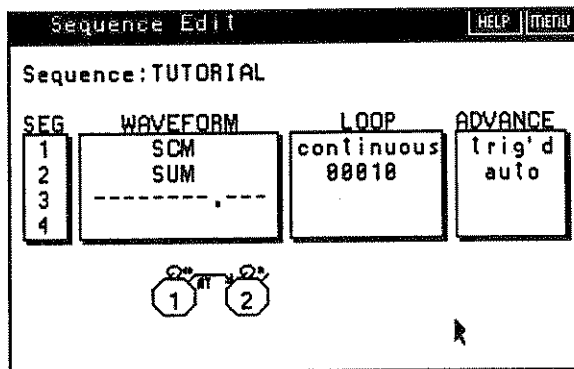

Figure 3-53. Sequence Edit Screen

Step 5 - Set up the Trigger Conditions for the Advance Triggers

Move the mouse cursor to the Sequence Edit screen's MENU "button". Click the left mouse button to display the Menu list; see figure 3-54.

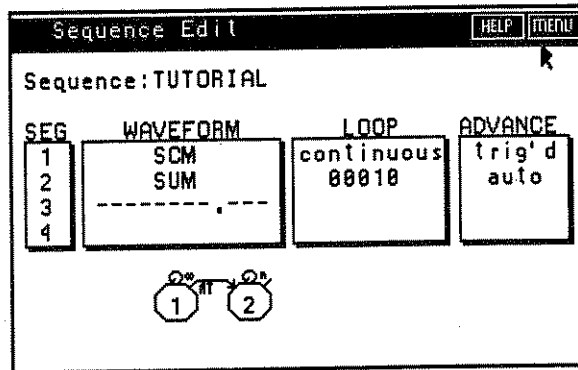

Figure 3-54. Sequence Edit - Menu "Button"

From the Menu list, Figure 3-55, select ADV TRG (advance trigger) using the mouse. This displays the ADV TRIG Setup screen.

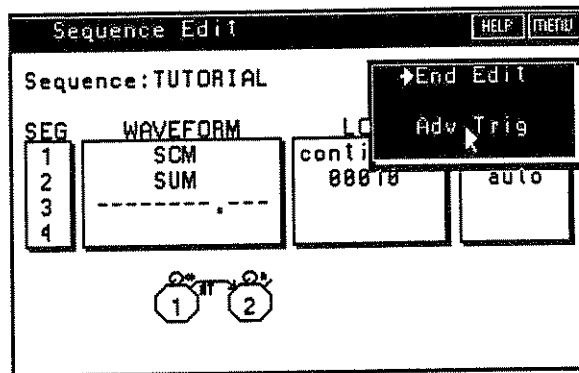

Figure 3-55. Advance Trigger

See figure 3-56. Use the mouse to select the triggering condition (EDGE) and timing (SYNC). Under these conditions, the sequence advances after receiving a trigger to segment 2 when the last cycle of segment 1 is completed. Select DONE to return the Sequence Edit screen. Define the trigger source via the Trigger Setup screens.

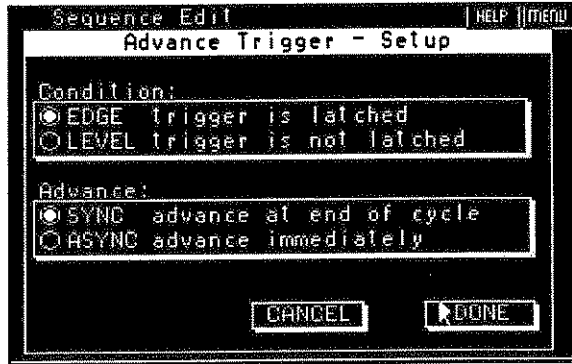

Figure 3-56. Advance Trigger Setup

Step 6 - Storing the Sequence

You must Store a sequence in order to "run" the sequence. When a sequence is stored, all the waveforms referenced in the sequence are automatically copied to the same storage location as the sequence.

To store a Sequence, move the mouse cursor to the Sequence Edit screen's MENU "button" and click the left mouse button displaying the Menu list. See figure 3-57.

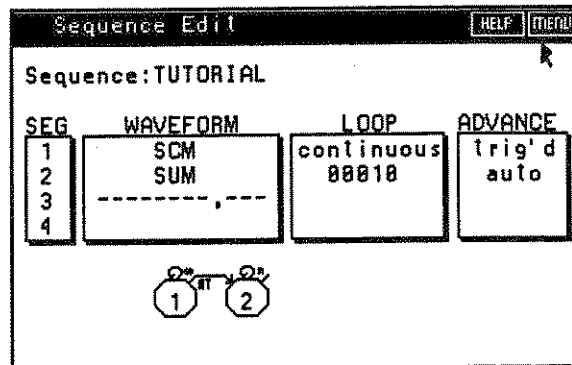

Figure 3-57. Sequence Edit Menu

Select END EDIT from the Menu list; see figure 3-58.

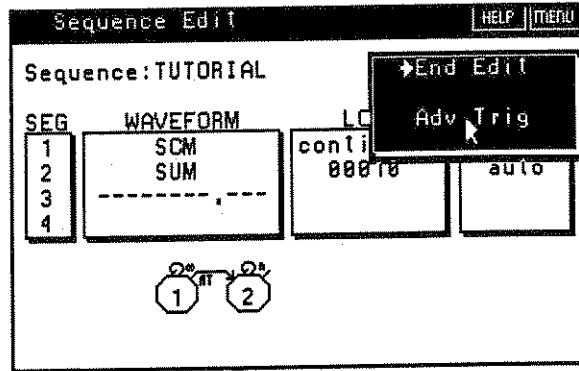

Figure 3-58. Selecting End Edit

Selecting END EDIT displays the Store screen; see figure 3-59. From this screen select where to store the Sequence. For this example, place the cursor on "Store in Battery-Backed RAM" and click the left mouse button. For information on other items on the screen, refer to section 4, Sequence.

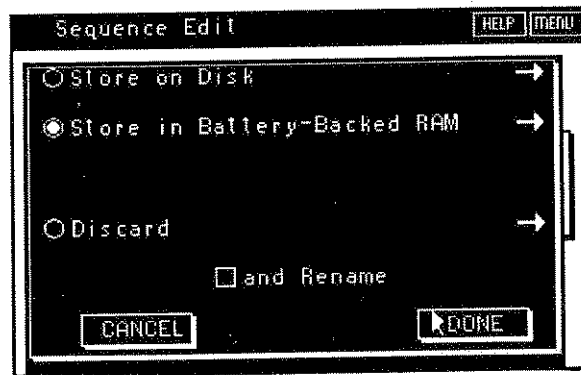

Figure 3-59. Store Screen

Summary of Sequence Example

The sequence just created in the example is now the current Function for the selected Channel. You can change the frequency, amplitude, and offset of the sequence using the Channel Setup screen. You will need to set up the Trigger Mode and Source to view the frequency properly. To do this, press the TRIGGER key to bring up the Trigger Setup Screen (Figure 3-60).

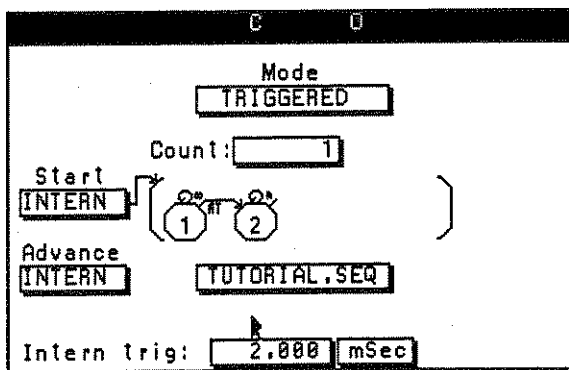

Figure 3-60. Trigger Setup Screen.

Change the Mode from CONTINUOUS to TRIGGERED, ensure that both "Start" and "Advance" triggers are set to INTERN, and change the "Intern trig:" value to 2.000 ms. Make sure that your screen is identical to Figure 3-60. This screen is interpreted as follows:

Every 2 ms an internally generated trigger signal triggers the waveform Sequence "TUTORIAL.SEQ". To start a sequence, the trigger signal starts waveform segment "1" (SCM). This waveform will run continuously (loop ∞) until an Advance Trigger ("AT" occurs 2 ms after the Start Trigger) switches the sequence to waveform segment "2" (SUM). The SUM waveform will loop "n" times (loop count is 10) and then stop at its *baseline* value. Since there are no more waveform segments in this Sequence, and the Sequence repeat "Count" is "1", the next trigger to arrive is the Start Trigger to restart the Sequence.

Now observe the TUTORIAL Sequence on your oscilloscope. Connect the Channel's MAIN OUT to CH1 and MARKER OUT (SYNC) to CH2 of the oscilloscope. Trigger the oscilloscope internally (negative slope) from CH2. Set the horizontal time base to 0.5 ms/DIV. Adjust vertical gain and position to display the signals. Adjust the oscilloscope's trigger level (and possibly trigger hold-off) to obtain stable synchronization.

The CH1 trace should start with the "SCM" waveform. At 4 DIV into the trace, it should switch to the "SUM" waveform for 10 cycles. This is followed by the baseline voltage out to 8 DIV, where the sequence restarts. The CH2 trace is low when the sequence is running and high during the baseline. Additionally, there are narrow positive sync pulses at the start of each waveform segment.

Editing a Sequence

Editing an existing sequence uses many of the same screens as used to create the sequence. The major difference is a sequence must first be selected from the Sequence Catalog. After selecting the Sequence to be edited, use the Sequence Edit screen to alter the Sequence.

INTRODUCTION

This section describes the Model 295 front and rear panel items, as well as its six main screens and the various menus for each screen:

- Channel Setup
- Trigger Setup
- Waveform (arbitrary waveforms)
- Sequence (linked arbitrary waveforms)
- Instrument Setup
- Utilities

This section does not tell you how to select an item, unless it is absolutely necessary. For an explanation on how to use the mouse or keys to select items from screen, refer to section 3, *Using the Mouse and Keypad*.

THE FRONT PANEL

Figure 4-1 illustrates the front panel of the Model 295. Numbers in this figure identify key or groups of keys that will be described in table 4-1.

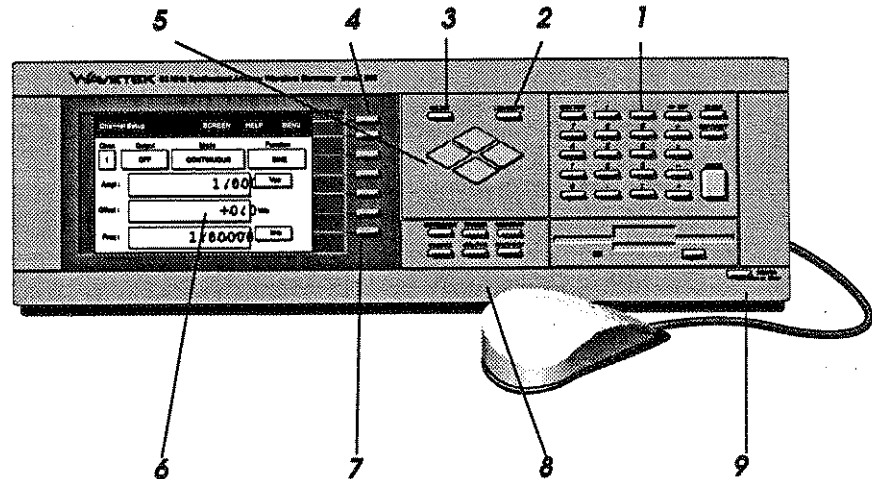

Figure 4-1. Front Panel

Table 4-1. Front Panel Controls

Name	Function
1. Number Pad	Used to type parameter values into the Model 295. Number Keys - "0" through "9". Symbols keys - Operators: "(" - left parentheses, ")" - right parentheses, "+" - divide, "X" - times, "-" - minus, "." - plus, and "," - comma.

Table 4-1. Front Panel Controls (Continued)

Name	Function
	<p>MAN TRIG (Manual Trigger). This key provides a manual method of "triggering" the selected Arb Channel.</p>
2. LCD/SCOPE	<p>BSP (Backspace). Moves the cursor left one character and deletes that character during data entry.</p>
3. SELECT	<p>CLEAR (Clear Entry). Deletes all characters entered since the last time the ENTER key was pressed.</p>
4. Menu	<p>EXPONENT. All values entered between EXPONENT and ENTER are interpreted as an exponential value.</p>
5. Arrows	<p>Used when editing a waveform on an oscilloscope. Toggles control between the LCD cursor on the front panel and the waveform cursor on the oscilloscope.</p>
6. LCD Display	<p>Selects or deselects the highlighted field (flashing) on the current display screen. Similar to the left mouse button.</p>
7. Soft Keys	<p>Calls up the additional menus depending on the selected screen. User chooses the appropriate menu for the task using the mouse or the keyboard.</p>
8. Screen Keys	<p>Moves the cursor around the screen display. In data entry use the Arrow keys to scroll through available digits or characters.</p>
	<p>The main channel of communication between the user and the instrument. It displays a menu-driven series of dialog boxes. The user can interact with the displays via the mouse or keys. For more details on the display, refer to section 4 of this manual.</p>
	<p>These six keys select items from pop-up menus. When the pop-up menu appears, press the "soft" key next to the desired item.</p>
	<p>These keys call up each of the six Model 295 main screens. The six main screens are described briefly here.</p>
	<p>INSTRUMENT. Press this key to bring up the instrument main screen which selects items that effect the entire Model 295. For more details on this screen, refer to Instruments Screens in this section.</p>
	<p>CHANNEL. Press this key to bring up the channel setup main screen which selects items that affect the individual channel cards. For more details on this screen, refer to Channel Setup Screens in this section.</p>
	<p>SEQUENCE. Press this key to bring up the sequence edit main screen which selects items that setup and alter the sequence of waveforms from the Model 295. For more details on this screen, refer to Sequence Screens in this section.</p>
	<p>WAVEFORM. Press this key to bring up the waveform edit main screen which selects items that create and alter arbitrary waveforms. For more details on this screen, refer to Waveforms Screens in this section.</p>

Table 4-1. Front Panel Controls (Continued)

Name	Function
Screen Keys (cont'd)	TRIGGER. Press this key to bring up the trigger setup main screen. From this screen, select trigger sources and destinations for the Model 295. For more details on this screen, refer to Trigger Setup Screens in this section. UTILITIES. Press this key to bring up the utilities main screen. From this screen select display viewing angle, beeper control, blinking rate, GPIB setups, and file operations. For more details on this screen, refer to Utilities Screens in this section.
9. POWER Switch	This switch controls the Model 295 primary power. Pressing the switch in turns the power on. Releasing (out) the switch turns the power off.

REAR PANEL

Figure 4-2 illustrates the rear panel of the Model 295. Numbers in this figure identify the connectors described in table 4-2.

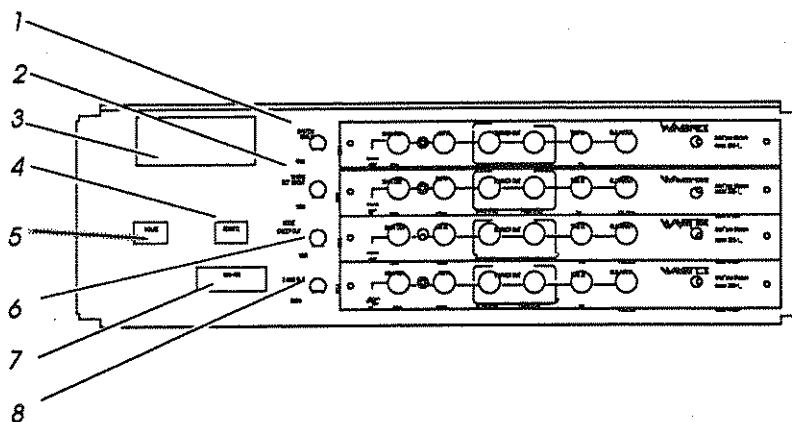

Figure 4-2. System Rear Panel Connectors

Table 4-2. System Input and Output Connectors

Name	Function
1. System Trigger	Triggers from one to four channels. User selects the triggered channels. Trigger slope and threshold level adjustable from -10 Volts (V) to +10V ($\pm 0.4V$) in 0.8V steps or TTL (Default).
2. 10 MHz REF IN	Used as an optional external clock signal input (TTL level). Requires better than 1% frequency accuracy. Also, use this connector for the 10 MHz reference output.
10 MHz REF OUT	Used as buffered TTL output of the internal 10 MHz system clock. Also, use this connector for the 10 MHz reference input.
3. Power Connector	The primary power input for the Model 295. This housing also contains the fuse.

Table 4-2. System Input and Output Connectors (Continued)

Name	Function
4. RS-232	DB-9 (female) RS-232 input and output. Connects the host computer to the Model 295. For more information, refer to section 5 of this manual.
5. MOUSE	DB-9 (male) connector for standard two-button mouse.
6. HORIZ SWEEP	A positive-going 0V to 10V ramp voltage proportional to the sweep signal for X-axis control of an external oscilloscope.
7. IEEE-488	GPIB input and output. Use to connect to other IEEE-488 devices. For more information, refer to section 5 of this manual.
8. Z-AXIS OUT OUT	Modulates intensity of waveform trace for an external oscilloscope to provide markers and highlighting for the waveform. Output levels (0 V to 9.4 V, in 40 mV steps) and polarities are selectable.

ARB CHANNEL BOARD

Figure 4-3 illustrates the Model 295 Arb Channel board connectors. Numbers in this figure identify connectors described in table 4-3.

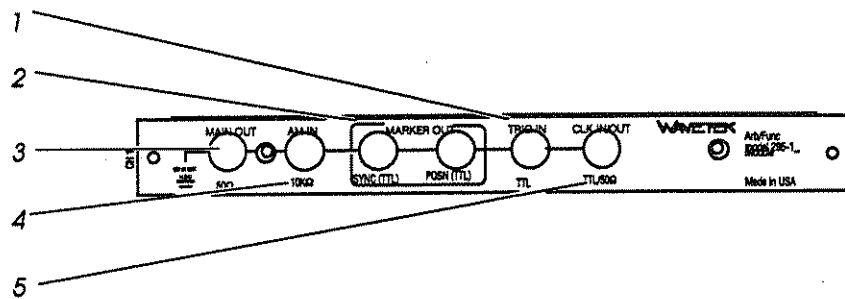

Figure 4-3. Channel Input and Output Connectors

Table 4-3. Channel Input and Output Connectors

Name	Function
1. TRIG IN	Trigger Input. Triggers the individual channel to start or to stop outputting a waveform. (TTL)
2. MARKER OUT	Sync Marker Output. Positive pulse whose leading edge coincides with the start of the output of the first point of the waveform data or zero-crossing point. Compatible with oscilloscope horizontal sync input. (TTL).
POSN	Position Marker Output. Positive pulse whose leading edge is programmable to coincide with the output of any or all data points on the waveform. (TTL)
3. MAIN OUT	Waveform Output. Discrete voltage levels describing the vertical positions of each of the points in the wave-

Table 4-3. Channel Input and Output Connectors (Continued)

Name	Function
4. AM IN	form. Output level is 0.015 to 15 V _{p-p} into 50 Ω and 0.03 to 30 V _{p-p} unloaded. AM Modulation Input. Modulates the output of the channel. Modulation bandwidth is dc to > 500 kHz. Modulation can be AM (double sideband with carrier) or SCM (double sideband suppressed carrier). Impedance is 10 k Ω .
5. CLK IN/OUT	Clock Input. Accepts an external TTL clock source for the Arb Channel between dc and 50 MHz. Clock Output. Provides a buffered TTL output of the internally generated channel clock signal. For standard waveforms the clock output is fixed at 50 MHz. For Arbitrary waveforms the clock output will be between 125.1 mHz and 50 MHz. If the high frequency clock output is selected (Channel Setup screen), the clock output can be programmed between 125.1 mHz and 100 MHz.

CHANNEL SETUP SCREEN

The Channel Setup screen is the first screen which appears after power-up. Figure 4-4 illustrates the Channel Setup screen and the following paragraphs describes the selectable items from this screen.

Chan	Output	Mode	Function
1	OFF	CONTINUOUS	SINE
Amp:	+ 1.000		Vp
Offset:	+ 0.000		Vdc
Freq:	1.0000000		kHz

Figure 4-4. Channel Setup Screen

Channel Numbers

The Model 295 uses channel numbers to identify each of its Arb Channel Boards. Each Model 295 can hold up to four Arb Channel Boards. The position of the Arb channel in the chassis defines the Arb Channel's number. If the unit has only one channel, you must install the board in Channel 1. For two Arb channels, you must place them in channels 1 and 2. For three Arb channels, use channels 1, 2, and 3. Use channels 1, 2, 3, and 4 with all four Arb Channels. For more information on Arb Channels locations and installation, refer to section 2, Installation, Arb Channel Installation and to Appendix G, High Voltage Option channel card installation and operation.

Changing Channel Numbers

To change a channel number (figure 4-5), select the "Chan" field. If there are two or more Arb Channels in the unit, a channel menu appears. Select the desired channel number. If the "Chan" field is flashing, you can use the keypad to enter a number (1 for channel 1, 2 for channel 2, etc.).

You must select the desired channel before creating, editing, or loading a waveform or sequence.

Chan	Output	Mode	Function
1	OFF	CONTINUOUS	SINE
Amp:	+ 1.000		Vp
Offset:	+ 0.000		Vdc
Freq:	1.0000000		kHz

Channel Selection Menu:

- 1
- 2

Figure 4-5. Channel Numbers

Output On/Off

At power on or after a channel reset, the Model 295 turns off the "MAIN OUT" for each Arb Channel. Before using an output signal, you must turn the output on. Also, you can turn the outputs off as needed. To change an output state (figure 4-6), bring up the Channel Setup screen. Select the Output button. Selecting Output toggles the Main Out on and off. When the output is on, the source impedance is 50Ω.

The screenshot shows the 'Channel Setup' screen with the following settings:

Chan	Output	Mode	Function
1	ON	CONTINUOUS	SINE
Ampl:		+ 1.000	Vp
Offset:		+ 0.000	Vdc
Freq:		1.0000000	kHz

Figure 4-6. Output On/Off

Modes

Model 295 modes select the Arb Channel's operating state: continuous, triggered, gated, and the three Sweep Modes. The triggered and gated modes require trigger signals to activate the function.

To change the mode, select the Mode field which displays a pop-up menu. Select a mode from the menu using either the mouse or the adjacent soft keys.

You can also select modes using the keypad. When the Mode field is flashing, use the keypad to enter a number of the desired mode; see below.

Mode	Number
Continuous	1
Triggered	2
Gated	3
Sweep Continuous	4
Sweep Triggered	5
Sweep Hold	6

Continuous

The Arb Channel output supplies a continuous function at the Main Output.

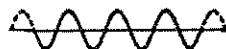

Triggered

Arb Channel output produces a *baseline* (dc level at the start point) until it receives a trigger signal. Then, it produces the programmed number of cycles (see trigger count, Trigger Setup) of the selected waveform before returning to the baseline.

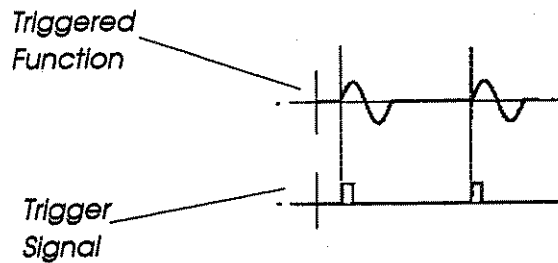

The baseline depends on the function selected. See the following list.

Function	Starting Point
Sine	0V
Square	Positive peak
Triangle	Negative peak
+Ramp	Negative peak
-Ramp	Positive peak
+Haversine	0V
-Haversine	0V
Sinc	-1/2 amplitude

For Waveforms, the baseline level depends on the waveform's start point. For Sequence, the level depends on the starting point of the first waveform segment used in the Sequence.

The maximum frequency of the triggered function depends on the function selected. For sine, square, and arbitrary waveforms (5 points), the maximum frequency is 10 MHz. All other standard functions limit the maximum frequency to 2 MHz.

See Trigger Setup screens for information on trigger sources and setup.

Gated

The Arb Channel output produces a baseline level until it receives a trigger signal. Then it produces a continuous output as long as the trigger signal remains true. When the trigger signal goes false, the output returns to the baseline level. See Triggered for information on the baselines of the various functions. See Trigger Setup for information on trigger sources and setup.

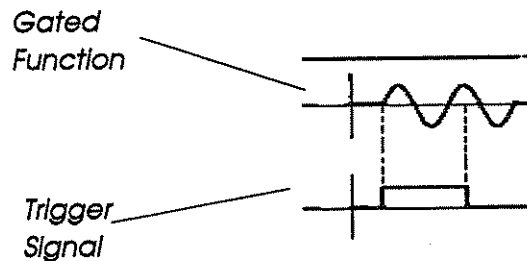

NOTE: The remaining modes are Sweep modes. Most of the sweep parameters are set up by choosing "Sweep" from the Channel Setup screen's menu.

In all Sweep modes the frequency field in the Channel Setup screen is dashed out (disabled). The frequency settings for sweep are set with the "Stop" and "Start" fields in the Sweep Dialog. See Sweep.

Sweep Cont

Sweep Cont causes the frequency to sweep continuously between the start and stop frequencies.

Sweep Trig

Sweep Trig causes the frequency to sweep between the start and stop frequencies after receiving a trigger. To set up the trigger source, refer to start triggers on Trigger Setup Screen. The trigger rate must be longer than the sweep time.

Sweep Hold

Sweep Hold (Triggered & Hold) causes the frequency to make one sweep between the start and stop frequencies holding at the stop frequency. Then after receiving a trigger signal return to the start frequency. To set up the trigger source, refer to Start Triggers on Trigger Setup Screen. The trigger rate must be longer than the sweep time.

Functions

Functions allow you to define the shape of the output waveform. All functions are synthesized and stored in Arb Channel memory. Functions fall into two main categories - Standard Functions and User-defined Functions.

Standard Functions

Standard Functions are predefined waveshapes which are selectable by common names, such as "sine", "triangle", or "square". The name of the waveshape implies certain characteristics of the waveform; such as shape, "smoothness", time and amplitude symmetry, periodicity, starting phase, and trigger baseline position.

Because Standard Functions are smooth and periodic, they are synthesized in a *phase accumulate* mode. This offers certain advantages. Clock frequency is fixed at 50 MHz and the waveform frequency is varied by varying the number of points used per waveform block. This allows higher overall maximum frequencies and 8 digits of frequency resolution (continuous mode, reduced to 5 digits for non-continuous modes). The fixed clock frequency allows the Model 295 to select the appropriate Filter for Standard Functions by default.

Standard Functions operate in all modes, but provide no trigger or position Marker outputs.

User-defined Functions

User-defined Functions are further subdivided as either "User-defined Waveforms" or as "Waveform Sequences".

"User-defined" Waveform is another way of saying *arbitrary* waveform. Because they are arbitrarily positioned, each point in the waveform must be used on each pass through the waveform block. Therefore for Waveforms, a *Raster Scan* synthesis technique is used, with one point per clock cycle and each point in the Waveform used once per waveform cycle. The sample frequency is synthesized with 5 digit resolution from 50 MHz to 0.1251 Hz. Waveform frequency is then the sample frequency divided by the number of points used in the Waveform.

User-defined Waveforms also function in all modes (although for Sweep modes they must adhere to certain rules - see Sweep). Trigger and position Markers are included as part of the waveform data.

Waveform Sequences link user-defined Waveforms together into complex sequences, where the condition for advancing from one waveform to the next is also user-defined. Sequences support only continuous and triggered modes of operation.

Function Selection

To change the function, select the function field which displays a pop-up list. Select a function from the list using either the mouse or the adjacent soft keys. To access all functions on the list, you will have to scroll down the list using either the slider box or down arrow key.

You can also select most of the functions using the keypad. When the Function field is flashing, use the keypad to enter a number of the desired function; see below.

Function	Number
Sine	1
Square	2
Triangle	3
DC	4
Positive Ramp	5
Negative Ramp	6
Sinc	7
Positive Haversine	8
Negative Haversine	9
Random	(none)
Waveforms...	*
Sequence...	*

**Included in the Function list, but not selectable by number. Selecting one of these functions with the mouse or soft key will pop up a submenu where a Waveform or Sequence can be selected from a list of previously created names or, a new waveform or sequence can be created.*

Sine

The Arb Channel produces a sinusoidal function programmable between 1 μ Hz and 20 MHz.

Triangle

The Arb Channel produces a triangle function programmable between 1 μ Hz and 2 MHz.

Square

The Arb Channel produces a square function programmable between 1 μ Hz and 25 MHz.

Positive Ramp

The Arb Channel produces a positive-going ramp function programmable between 1 μ Hz and 2MHz.

Negative Ramp

The Arb Channel produces a negative-going ramp function programmable between 1 μ Hz and 2MHz.

Sinc (Sin(X)/X)

The Arb Channel produces a (Sin X)/X function which is programmable from 1 μ Hz to 2MHz.

Positive Haversine

The Arb Channel produces a positive-going haversine function which is programmable from 1 μ Hz to 20 MHz.

Negative Haversine

The Arb Channel produces a negative-going haversine function which is programmable from 1 μ Hz to 20 MHz.

Random

The Arb Channel produces a random function (noise).

Waveform

The Arb Channel produces a user-defined arbitrary waveform. To create, edit, and copy a Waveform, see *Waveform Screens* later in this section. Also, to Load an arbitrary Waveform from an existing waveform file (created by the model 295, Wavetek's Waveform DSP™ arbitrary waveform software, or by another application such as a spreadsheet) refer to the information under *Load Waveforms* in the section on *Waveform Screens* later in this Section. Selecting the Waveforms function displays the Waveforms Catalog (figure 4-7).

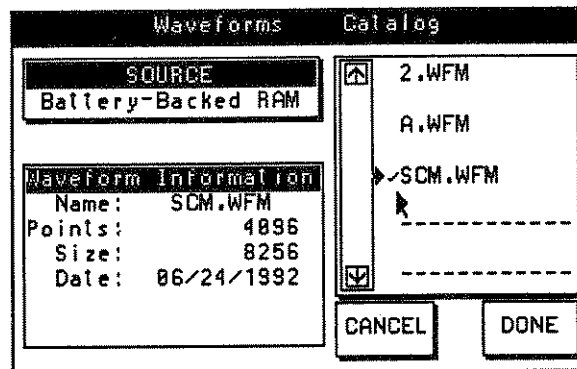

Figure 4-7. Waveforms Catalog

From the Waveform Catalog select SOURCE to display the source list:

Disk Drive (if installed),
Battery-Backed RAM,
Selected Channel.

Selecting a source displays a list of the waveforms stored in that source. An arrow identifies the current selection, if applicable. Select a waveform from the list. A check (✓) identifies the newly selected waveform. The Information box displays the waveform's name, number of points, and size in bytes. The date identifies when the waveform was last saved.

Select DONE to accept the waveform and return to the Channel Setup Screen. Select CANCEL to keep to the original function while returning to the Channel Setup Screen.

Sequence

The Arb Channel produces a user-defined Sequence (linked arbitrary waveforms). To create, edit, and copy a Sequence, see Sequences in this section. Sequences may require trigger sources and setup, if so, see Trigger Setup Screens in this section.

Selecting sequence calls up the Sequences Catalog (figure 4-8).

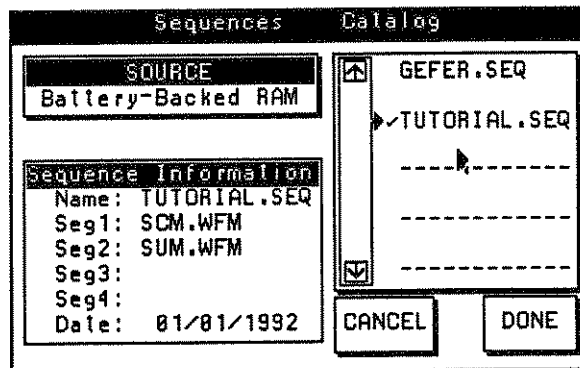

Figure 4-8. Sequences Catalog

From the Sequences Catalog select SOURCE which pops up the source list:

Disk Drive (if installed),
Battery-Backed RAM.

After selecting a source, the Sequences stored in that source are displayed in a list. An arrow identifies the current selection, if applicable. Select a Sequence from the list. A check (✓) identifies the newly selected Sequence. The Sequence Information screen also displays each waveform *segment* name. The date identifies when the Sequence was last saved.

Select DONE to accept the Sequence and return to the Channel Setup Screen.

Select CANCEL to keep the original function and return to the Channel Setup Screen.

Amplitude

Amplitude sets the voltage level of the signal from the Arb Channel's Main Out connector. Figure 4-9 shows the Amplitude field from the Channel Setup Screen. The Amplitude field displays the current level. The programmable amplitude level depends on the function and units of measure selected; see table 4-4. The peak amplitude value plus the offset value can not exceed 7.5V.

The Amplitude value is set to 0.000 when the DC Function is selected. In this case, the Amplitude Field is filled with dashes to indicate that the value cannot be changed.

The "Amplitude units of measure" field allows you to change the units for the amplitude. From the pop-up menu select the desired units (Vp-p, Vp, Vrms, and dBm). This field only displays the acceptable units of measure for the function.

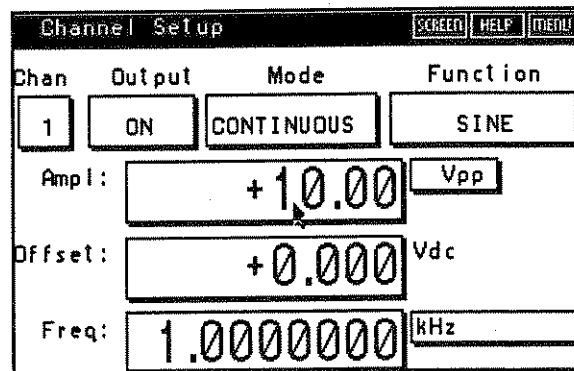

Figure 4-9 . Amplitude

Table 4-4. Amplitude (max.) / Units of Measure Vs. Function

Function	Vp	Vp-p	Vrms	dBm
Sine	7.5	15	+5.303	+27.5
Square	7.5	15	+7.5	+30.51
Triangle	7.5	15	+4.33	+25.74
+Ramp	7.5	15	+4.33	+25.74
-Ramp	7.5	15	+4.33	+25.74
Sinc	7.5	15	NA	NA
+H-Sine	7.5	15	+2.652	NA
-H-Sine	7.5	15	+2.652	NA
Random	7.5	15	NA	NA
Waveforms*	7.5	15	NA	NA
Sequence*	7.5	15	NA	NA

Notes: All values measured with 50Ω termination

NA Not Available.

* Output level may be a percentage of amplitude when created.

DC Program the dc function using OFFSET.

If Modulation - AM is selected, the display shows (AM) to the left of the Amplitude value. For AM the amplitude value represents the Main Out signal at 100% modulation. For more information on AM, refer to Amplitude Modulation under the Channel Setup Screen's Menu "button".

If Modulation - SCM is selected, the display shows (SCM) to the left of the Amplitude value. For more information on SCM, refer to Suppressed Carrier Modulation under the Channel Setup Screen.

Offset

Offset varies the dc level of a function relative to a baseline value; see figure 4-10. The offset can be varied up to $\pm 7.5\text{Vdc}$ into a 50Ω termination. To change the offset value, select Offset field and enter the new value. The offset value plus the peak amplitude can not exceed 7.5V . In the DC mode, the Offset field controls the output level.

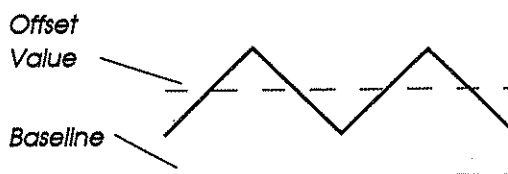

Figure 4-10. Offset

Frequency

Frequency sets the repetition rate of the selected function. Figure 4-11 illustrates two items: the frequency value field and the frequency unit of measure field. If time is selected, "Freq:" is replaced with "Period:". For sweep modes the word "Sweep" appears to the left of the Frequency value. If the Channel is part of a Clock Group (see Instrument Screen - Channel Group), Then the word "Master" will appear to the left of the Frequency value. The frequency displayed in the frequency field is the actual programmed master frequency and not necessarily the programmed Arb channel frequency. Plus, the frequency field will be disabled (dashed) when the dc function is selected or when the Arb Channel is sweeping.

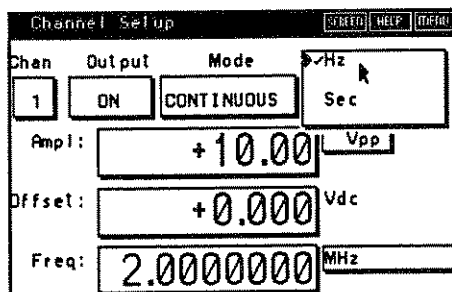

Figure 4-11. Frequency

Frequency Field

Select the frequency field and use the keypad to change the value. For all Standard Functions the minimum frequency is $1\mu\text{Hz}$. The maximum frequency for Standard Functions and frequency resolution depend on the function selected; see Tables 4-5 and 4-6.

Table 4-5. Function Versus Frequency

Function	Maximum Frequency
Square	25 MHz
Sine	20 MHz
Triangle	2MHz
\pm Ramps	2MHz
\pm Haversine	20 MHz
Sin(X)/X	2MHz

If a User-defined Waveform is selected, the Model 295 programs the Waveform repetition rate in frequency or period (1/f). The maximum frequency (minimum period) for a Waveform depends on the number of points in the Waveform and the programmed Waveform Limits (see Waveform Active Screen). For example, a 1000 point Waveform (whose Limits are set to Start at 0 and Stop at 999) can only have a maximum frequency of 50 kHz (50 MHz sample frequency ÷ 1000 points). Also, you can program the Waveform in terms of sample frequency (clock frequency) or sample period (clock period).

If a Sequence is selected, you can only program Sequences in terms of sample frequency or sample period.

Table 4-6. Function/Frequency Versus Frequency Resolution

Function	Frequency	Frequency Resolution
Sine, square, Haversines	≤ 20 MHz	8 digits (1 μHz)
	> 20 MHz	5 digits
Ramps, triangle, sinc	< 100 kHz	8 digits (1 μHz)
	≥ 100 kHz	5 digits
User-defined	any	5 digits (0.1 mHz)
Clock Mode	any	5 digits

Unit of Measure Field

Select this field to change the frequency unit of measure. When selected, a menu appears; see figure 4-12. Pick an item from this menu. This field displays only acceptable units of measure, which is dependent upon the current function.

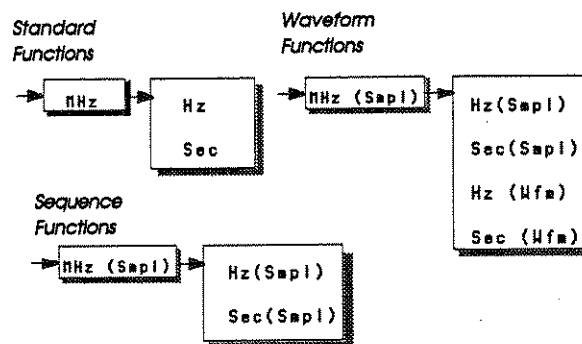

Figure 4-12. Units of Measure

Channel Setup Menu Field

Selecting the MENU "button" at the top right corner of the Channel Setup screen (or the top dark gray soft key) displays a Menu which allows you to select additional Channel Setup options. From the Channel Setup Menu you can select filters, change modulation, define clocks, set up the sweep mode parameters, adjust phase, and control the sync marker state.

Filters

Each of the Model 295 Arb Channels contains two internal filters. Use filters (Elliptic and Bessel) to remove unwanted signals (aliasing and DAC clock signals). The seven-pole, six-zero Elliptic filter provides a sharp cutoff at 20 MHz. The four-pole Bessel filter provides a less sharp cutoff at 20 MHz, but it provides flatter response and constant group delay. Another choice is "no filter".

The Model 295 automatically selects filters at the time a Function is selected. For triangle, +ramp, and -ramp, the Model 295 inserts the Bessel filter. For sine, +haversine, -haversine, square, and sinc, the Model 295 inserts the Elliptic filter. For all other functions all filters are removed.

To change the filters (figure 4-13), pick one of the three filter "radio" buttons. Choose DONE to remove the FILTER dialog.

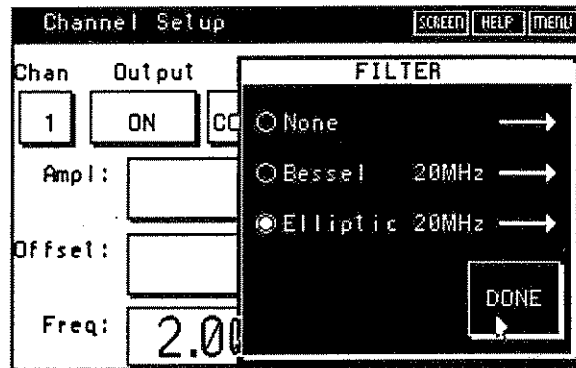

Figure 4-13. Filter

Modulation

The Model 295 allows you to select two forms of modulation: Amplitude Modulation (AM) and Suppressed Carrier Modulation (SCM). Figure 4-14 illustrates the modulation menu. After selecting the Modulation type, press the DONE button to remove the MODULATION dialog.

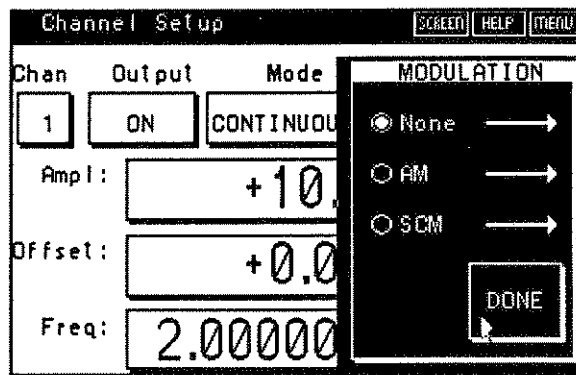

Figure 4-14. Modulation Menu

Amplitude Modulation

In amplitude modulation, a modulating signal at the Arb Channel's AM IN connector controls the instantaneous magnitude of the Arb Channel's Main Output. The Arb Channel produces the carrier (frequency, amplitude, and function). All functions including Waveforms and Sequence can be amplitude modulated. With no modulating signal applied to the input, the Main Out signal is half the programmed Amplitude value, allowing up to 100% Amplitude Modulation.

The level of the modulating signal to produce 100% modulation depends on the range of the programmed Amplitude; see Table 4-7. The values shown in the list represents the level needed to produce 100% modulation. Within each range, the scale factor is linear, which means the percentage of modulation is proportional to the modulation input level (1V = 100%, 0.5V = 50%, etc.).

Table 4-7. AM Scale Factor

Programmed Amplitude	Amplitude where 1Vp-p @ AM IN Results in 100% AM
≤15 Vp-p to >5Vp-p	10Vp-p
≤5Vp-p to >2.5 Vp-p	5Vp-p
≤2.5 Vp-p to >1.25 Vp-p	2.5Vp-p
≤1.25 Vp-p to >625 mVp-p	1.25Vp-p
≤625 mVp-p to >312.5 mVp-p	0.625 Vp-p
≤312.5 mVp-p to >156.3 mVp-p	312.5 mVp-p
≤156.3 mVp-p to >78.13 mVp-p	156.3 mVp-p
≤78.13 mVp-p	78.13 mVp-p

Suppressed Carrier Modulation

In suppressed carrier modulation (SCM), the Arb Channel operates much the same as in AM. The main difference is that the Arb Channel output supplies 0V with no modulating signal at AM IN.

When SCM is selected, the Model 295 uses a scale factor, $5V_{out}/V_{in}$, which represents the output voltage to input voltage ratio. For example, if the Amplitude field displays (SCM), applying 1Vp-p at the MOD IN connector produces a SCM signal at the Main Out connector whose level equals 5Vp-p.

Sweep

Select a Sweep Mode by selecting Mode in the Channel Setup screen, then select either Sweep Cont, Sweep Trig, or Sweep Hold. The sweep parameters in the following screen define what a single, complete sweep consists of. These three sweep modes define how sweeps will be strung together. When Sweep Cont is selected, the generation of frequency sweeps is continuous, without the need of a triggering event. The Sweep Trig mode completes one full sweep (using the sweep parameters below) for each trigger. The Sweep Hold mode is similar, except that it requires two triggers to complete a full sweep; one to get from the start frequency to the stop frequency, and one to get back to the start frequency.

Any of the Standard functions can be run in the various Sweep Modes. User-defined Waveforms can also be run in Sweep Modes, but there are two restrictions:

1. The User-defined Waveform must be a multiple of 4096 points.
2. The Waveform must be the only one currently loaded into the Channel's waveform RAM.

Sequences can not be run in Sweep Mode.

Figure 4-15 illustrates the SWEEP SETTINGS menu. The SWEEP SETTINGS screen sets sweep type, spacing, and direction. It also sets the sweep time, start frequency, and stop frequency. The Model 295 uses digital sweep which sweeps between the start and stop frequencies at a maximum of 400 steps/second in the selected sweep time.

The screenshot shows a menu titled "SWEEP SETTINGS" with a "HELP" button in the top right corner. The parameters are as follows:

- Type: SWEEP & RESET
- Spacing: LINEAR
- Direction: UP
- Count: 1
- Time: 1.000 Sec
- Start: 1.00000 kHz
- Stop: 10.0000 kHz

A "DONE" button is located to the right of the Time field.

Figure 4-15. Sweep Menu

TYPE toggles between "Sweep & Reverse" and "Sweep & Reset". "Sweep & Reverse" sweeps the frequency from the start frequency to the stop frequency and sweeps back to the start frequency. "Sweep & Reset" sweeps the frequency from the start frequency to the stop frequency. Then the frequency resets to the start frequency. These two "sub-modes" can be concatenated with each of the three sweep modes described above.

SPACING toggles between LINEAR sweep or LOG (logarithmic) sweep. Linear sweep changes the frequency at a linear rate. Logarithmic sweep causes the frequency to spend equal time in each octave or decade.

COUNT selects the number of complete sweeps (number of sweep times) the Arb Channel produces when triggered. Count functions only with Sweep Trig or Sweep Hold modes. Acceptable count values are 1 to 1,048,575.

TIME sets the sweep time, which is the time it takes to produce one sweep transition between start and stop frequencies. Program the sweep time in seconds between 30 ms to 1000s using the keypad or mouse.

Select the START field to program the sweep start frequency or period. Select the STOP field to program the stop frequency or period. The start/stop range depends on the function selected. All functions use a minimum frequency of 1 μ Hz. The maximum frequency for a given function varies according to Table 4-5. (User-defined Waveforms are programmed in waveform frequency, and have a maximum of 20 MHz). You can program Sweep frequency parameters in period (seconds) as well as in Hz.

DIRECTION toggles between UP or DOWN. UP causes the Arb Channel to sweep between the start and stop frequencies. Select DOWN to sweep between the stop and the start frequencies.

Select DONE to end SWEEP SETTINGS and return to the Channel Setup screen. If the current Mode is not one of the three Sweep Modes, the Mode field will be selected automatically.

Clock BNC

This menu performs two functions. It sets up the Clock mode and controls the Arb Channel clock. Selecting any clock output displays a warning message reminding you to disconnect any sources connected to "Clock In." Figure 4-16 illustrates the CLOCK BNC USE screen.

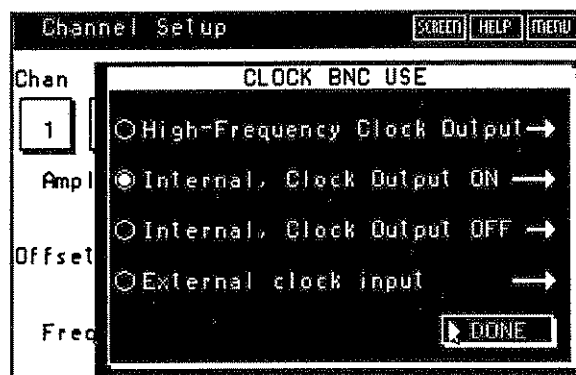

Figure 4-16. Channel Clock

High Frequency Clock Output

This will route a programmable frequency (0.125 Hz to 100 MHz) clock signal to the CLOCK IN/OUT BNC.

CAUTION: Make sure there are no signal sources connected to the Channel's CLOCK IN/OUT BNC when you choose this option.

The High Frequency Clock Out functions only while the Clock Mode box (Figure 4-17) appears on the screen, after selecting "High Frequency Clock Output" from the previous screen.

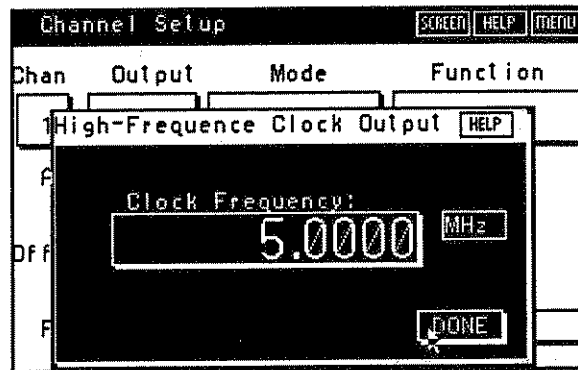

Figure 4-17. High Frequency Clock Output

To change the clock frequency, select the Clock Frequency field. Next use the mouse, arrow keys, or numeric keypad to change the frequency. The unit of measure can not be changed. The Arb Channel remains in the Clock mode while this screen is being displayed. Selecting DONE leaves the Clock mode and returns to the last Channel Setup. Clock mode signal is TTL into 50Ω.

Internal Clock Output OFF

The Channel will use its own internally generated clock, and will not output this clock signal to the CLOCK IN/OUT BNC.

Internal Clock Output ON

The Channel will use its own internally generated clock, and will output this clock signal to the CLOCK IN/OUT BNC.

CAUTION: Make sure there are no signal sources connected to the Channel's CLOCK IN/OUT BNC when you choose this option.

External Clock

The Channel will use the external clock signal clock signal applied to the CLOCK IN/OUT BNC. When you apply your own clock input to the channel, frequency programming via the Frequency field on the Channel Setup screen will operate as follows:

1. For Standard Functions (and User-defined Waveforms in Sweep Modes), the waveform frequency is the programmed waveform frequency times the external clock frequency divided by 50 MHz.
2. For User-defined Waveforms (in non-Sweep Modes), the waveform frequency is equal to the external clock frequency divided by the number of points in the Waveform. The programmed frequency has no effect on the Channel's output.

Phase

This menu option allows you to control the phase of the current function on the selected Channel. Phase control is valid except when the function is a Sequence. The selected functions must all be Standard Functions, or User-Defined with the same number of points.

Phase Control is applicable for Multi-Channel operation. See the Instrument Screen Menu, Multi-Channel, Channel Grouping, Phase Lock for additional information. When set up for Phase Lock operation, one channel is used as the phase reference and the other channel(s) may be varied in phase.

Phase may be controlled between $\pm 180^\circ$. The Phase control for Standard Functions allows for 0.1° resolution. The Phase control for User-defined Waveforms is accomplished in the following manner. The first time Phase is adjusted, two copies of the Waveform are created such that the size doubles, then the Waveform limits are set for the desired phase effect. For each subsequent phase adjustment, the limits are adjusted accordingly. The limitations to this process are:

1. The maximum Waveform size which can be Phase adjusted is one-half the available Channel RAM.
2. The resulting Phase resolution is 360° divided by the number of points in the Waveform.

To change the phase, select PHASE... from the Menu dialog box; see figure 4-18. This box gives you two methods of varying the phase. One, you move the slider box up towards $+180^\circ$ or down towards -180° . The phase field displays the value with the appropriate resolution. Also, you can select the Phase field and then use the keypad to enter the phase shift.

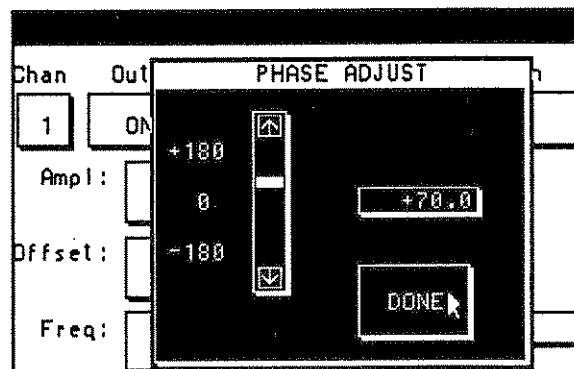

Figure 4-18. Phase Dialog Box

Sync Marker

The Arb Channel generates a Sync Marker output coincident with the Main Out function. For standard functions, the Sync Marker is coincident with the zero-crossing point of the function. For User-defined Waveforms, the Sync Marker is coincident with the first points (addresses) of the Waveform.

NOTE: There are two exceptions to this:

- 1) *When run in Triggered mode, the sync marker will always be coincident with the first points in the waveform, regardless of the Function.*
- 2) *For Positive Haversine, Negative Haversine, and Random, the sync marker will always be coincident with the first points in the waveform.*

The Sync Marker menu (figure 4-19) allows you to turn on or turn off the Sync Marker. The Sync Marker is automatically turned on each time the channel output is turned on. This menu allows you to override this automatic selection. Select DONE to return to the Channel Setup screen.

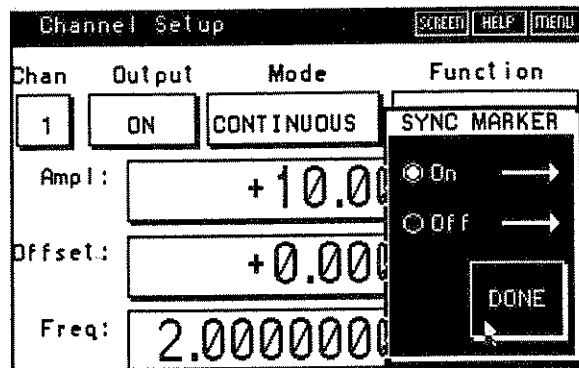

Figure 4-19. Sync Marker

TRIGGER SETUP

Trigger Setup screen allows control of the trigger parameters. From the Trigger Setup screen you can select an Arb Channel, the trigger mode, and the function. Most importantly, you can select the trigger source(s) and conditions. However, to set up the frequency, amplitude, and output state of the selected Arb channel, you must use the Channel Setup Screen.

To set up the trigger conditions (figure 4-20) select TRIGGER via the SCREEN field to bring up the Trigger Setup screen. Pressing the TRIGGER key also gets you to the Trigger Setup screen. The following paragraphs describe the Trigger Setup screen and its items. The graphics shown in figure 4-20 represent a sample of a typical Trigger Setup screen after TRIGGERED Mode is selected. The Mode and Function selected, as well as the number of Arb Channels installed, determine what appears on the screen.

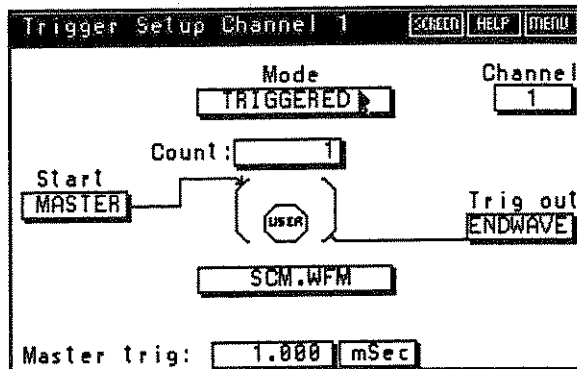

Figure 4-20. Trigger Setup Screen

Channel "Button"

The screen shows a Channel "button" if two or more Arb Channels are installed in the unit. The number, if displayed, identifies the current channel. To change a channel number, select the Chan field and select the new channel from the menu. Remember, the list only contains Arb Channels installed in your unit. You must return to the Channel Setup screen to change the frequency, amplitude, or offset, and to turn the output on.

Mode Field

Selecting this field allows you to change the operating mode. Change the mode (TRIG MODE) by selecting the mode field. This displays the mode list: Continuous, Triggered, Gated, Sweep Continuous, Sweep Triggered, and Sweep Hold.

With the Continuous mode selected, the Model 295 produces a continuous function output.

With the Triggered mode selected the Model 295 begins in a quiescent state. Upon receiving a trigger (see START field) it generates the function (see Function field) for a user-defined number of cycles (see COUNT field) before returning to the quiescent state. The Arb Channel always completes the last cycle.

With the Gated mode selected, the Model 295 produces an output while the trigger remains true. The Arb Channel always completes the last cycle. Use the START/GATE field to select the trigger source and the Function Field to select the function.

For two of the sweep modes (sweep triggered and sweep hold), use the trigger setup screen to define the sweep triggering conditions.

For more information on Modes, see "MODES" under the Channel Setup screen.

Count Field

This field selects the number of cycles the unit produces when triggered. You can select between 1 and 1,048,575 cycles. For sequences, maximum count is 524288.

If you select a count of one in the Triggered mode, the Model 295, when triggered, produces a single cycle of the selected function. This is the traditional triggered mode.

If you select a count of more than one in the Triggered mode, the Model 295 produces that number of cycles of the selected function. This is the traditional burst mode. In the Gate and Sweep modes, the Count field does not appear on the screen.

Function Field

Selecting this field allows you to change the Arb Channel's functions. Figure 4-21 lists the functions. In all standard functions, the output changes immediately. If you select either Waveform... or Sequence... the Model 295 displays their respective catalogs (see Waveform Catalog or Sequence Catalog). Select the function using the mouse's pointer or clicking on the Soft keys.

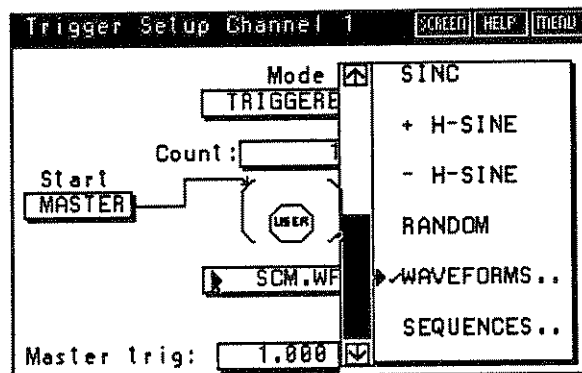

Figure 4-21. Function List

Trigger Start (Source) Field

This field's name, START / GATE / SWEEP START, varies with Mode selections. Selecting this field allows you to select the trigger source. The sources available depend on the number of Arb Channels installed in the unit.

To select the source, point the mouse pointer at the Trigger Source field and click the button.

Table 4-8 lists the START field choices. The list shown depends on the Arb Channel selected and number of Arb Channels installed.

Table 4-8. Channels Vs. Trigger Sources

	A	B	C	D	E
System Trig In BNC	•	•	•	•	•
Master Trigger (Ch 1 Internal)		•	•	•	•
Channel's Internal Trigger	•				•
Channel's External Trigger	•	•	•	•	•
Channel 2 Trigger Output		•	•	•	
Channel 3 Trigger Output		•	•		
Channel 4 Trigger Output		•			
Previous Channel's Trig Out					•

NOTES:

- A. Arb Channel 1 only.
- B. Viewing Trigger Setup Channel 1 with all four Arb Channels installed.
- C. Viewing Trigger Setup Channel 1 with three Arb Channels installed.
- D. Viewing Trigger Setup Channel 1 with two Arb Channels installed.
- E. Viewing Trigger Setup for any other Arb Channel except Arb Channel 1.

System Trigger Input BNC

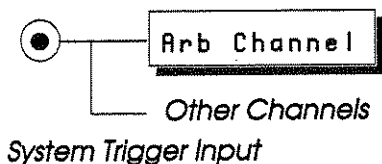

Selecting System Trigger Input BNC allows an external signal connected to the Model 295 System Trigger BNC to trigger the selected Arb Channel. Use this system trigger to trigger from one to four channels. Also, selecting System Trigger Input allows you to use the front panel's MAN TRIG key as a trigger source.

Refer to "Trigger Setup Menu - System Trigger Level" for setting the Level and Slope of the system trigger.

Master Trigger (Ch1 Internal)

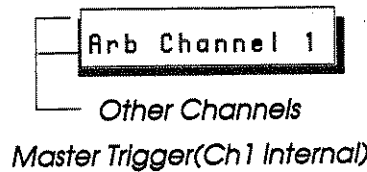

Selecting Master Trigger uses the internal trigger generator output from Arb Channel 1 as the internal trigger source. You can trigger any or all of the channels, including channel 1, from this source. The internal trigger rate (see Internal Trigger Rate Field) is programmable in frequency or period between 100 μ Hz and 5MHz (10,000s and 200 ns with 200 ns resolution).

Channel's External Trig In BNC



Channel's External Trig In BNC allows you to use the Arb Channel's own TRIG IN connector as its trigger source (TTL levels). The Arb Channel triggers independently of the other Arb Channels. Practical TRIG IN frequency range is dc to the waveform frequency. You can select the trigger slope (positive or negative) via the Menu choice "Channel Trig Polarity".

Channel 2 Trigger Output

Channel 3 Trigger Output

Channel 4 Trigger Output

These three items will only be seen on Arb Channel 1 Start list when there are multiple channels installed. Figure 4-22 gives a schematic representation of trigger signal flow. They allow you to select an output from one of the other channels as a trigger source. The list includes only the installed channels. See Trigger Out Field for a definition of the possible trigger output signals.

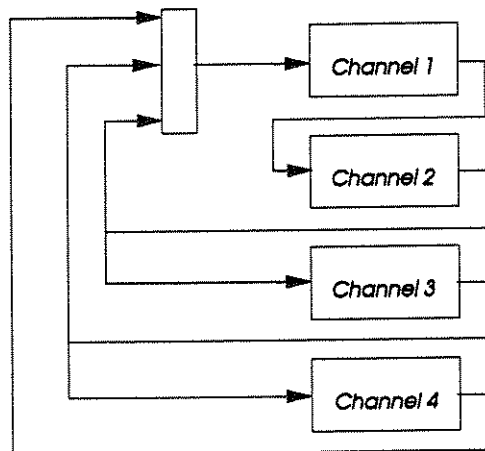

Figure 4-22. Trig Out Signal Flow

Previous Channel's Trig Out

Previous Channel's Trig Out allows you to trigger an Arb Channel off the preceding Arb Channel. Figure 4-22 gives a schematic representation of trigger signal flow.

Advance Field

The trigger screen displays an Advance field if a sequence is selected with an advance trigger condition. Selecting this field displays a trigger source list identical to the one displayed under the Trigger Start field. See Table 4-9. The advance trigger will be the same for all segments in the Sequence which have Advance Trigger conditions (see Figure 4-53).

Trigger Out Field

The trigger out field allows you to select which events initiate a trigger output signal. The trigger out signal can be internally routed to the START field for another Arb Channel (see Figure 4-22).

In order to have a Trigger Output signal which can be internally routed to another channel, the channel must be running a user defined Waveform or a Sequence. Standard Functions do not have a Trigger Output due to the nature of their synthesis. The list of available Trigger Output signals depends upon the current Function and Mode of operation, per Table 4-9.

Table 4-9. Function/Mode Vs. Trigger Outputs

Function	Mode	Trigger Output Signal
Standard	any	None
User Defined Waveform	Triggered	1) Waveform Complete signal occurs coincident with the end of the waveform. 2) Trig Count Complete signal occurs with the end of the last waveform in the trigger count.
	All others	Waveform Complete signal occurs coincident with the end of the waveform.
User Defined Sequence	Continuous	1) Waveform Complete signal occurs coincident with the end of the waveform. 2) Loop Count Complete signal occurs with the end of the last waveform in the loop count.
	Triggered	1) Waveform Complete signal occurs coincident with the end of the waveform. 2) Loop Count Complete signal occurs with the end of the last waveform in the loop count. 3) Trig Count Complete signal occurs with the end of the last waveform in the trigger count.

NOTE: When the current function is a Sequence, the Waveform Complete Signal and the Loop Count Complete Signal is associated with the selected Waveforms in the Sequence. You must check the boxes next to the Waveform names in the Sequence while the Trigger Output pop-up screen is being displayed.

The Trigger Output signals which are stated to be coincident with the end of a waveform are actually set to be coincident with the last point in the waveform (see Waveform:Active:Limits) minus 8 points. This is to optimize the trigger delay between two channels running at the same frequency.

Trigger Setup Menu Button

The Menu button on the trigger setup screen allows you to set up the system trigger and the channel trigger.

System Trigger Level

Selecting System Trig Level permits you to select type, level, and Slope (see figure 4-23). To set the type, select the type field which toggles between TTL and Variable.

Adjust the trigger level via the slider box or a level field (see figure 4-23). Trigger level variable: -10V and +10V in 80 mV steps.

Slope field toggles between Negative and Positive slope.

Select DONE when finished.

Channel Trigger Polarity

Selecting Channel Trig Polarity allows you to change the trigger slope for the Arb Channel external trigger input. Selecting Slope toggles the slope between Negative (falling edge) and Positive (rising edge). Select DONE when finished.

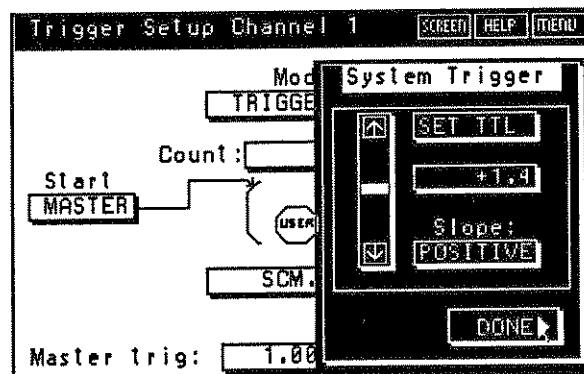

Figure 4-23. Trigger Level Screens

ARBITRARY WAVEFORMS..

Arbitrary Waveforms are user-defined Functions. Each Waveform has a name and a specific number of waveform memory points: between 5 and 32K standard points. Optional 128K or 512K waveform memory allows up to four channels each with 32K, 128K, or 512K of memory to be installed. Waveforms can be created, edited, stored, and run. There are three possible locations for a Waveform:

1. Battery Backed RAM - stored
2. Disk (optional) - stored
3. Channel RAM - not stored

When a Waveform is selected as the function output, the following will occur:

If it is selected from the disk or Battery-Backed RAM, it will load into the current Arb Channel's RAM and then run.

If it is selected from the current Arb Channel's RAM, it just runs.

There are certain waveform parameters which can be altered while a Waveform is running or "Active". These include waveform position markers and the start/stop points of the waveform. Waveforms may be linked together to form sequences - see Sequences.

The Waveform Management Screen is the entry point for creating, editing and manipulating User Defined Waveforms. To display the Waveform Management screen, press the WAVEFORM key or select Waveforms via the SCREEN field from any screen. Figure 4-24 illustrates the Waveform Management Menu.

The following paragraphs will guide you through the various Waveform screens starting from the main Waveform Management screen. To create (New) and edit Waveforms, you should use an oscilloscope as a display of the waveform; see New Waveforms or Edit Waveforms for details.

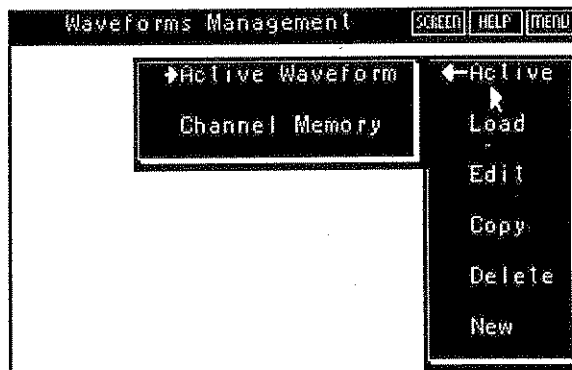

Figure 4-24. Initial Waveforms Screen and "Active" Sub-menu

Active (Waveform Information)

Selecting "Active" from the Waveforms Management menu brings up a sub-menu (see Figure 4-24) which selects between the current Active Waveform and the waveforms currently in the selected Channel Memory.

Active Waveform

The Active Waveform Parameters screen (Figure 4-25) allows certain parameters to be changed on the active (running) Waveform. The active waveform is the one that is running on the current Arb Channel. The parameters which can be varied include the name, channel, position markers and waveform start/stop points (Limits). The source, and size (created) of the active waveform are displayed for reference and can not be changed.

If the current channel is not running a User-Defined Waveform, the Active screen will not be displayed.

NOTE: If the current function is a Sequence, then the Active Waveform screen will allow the waveform segments in the Sequence to be controlled.

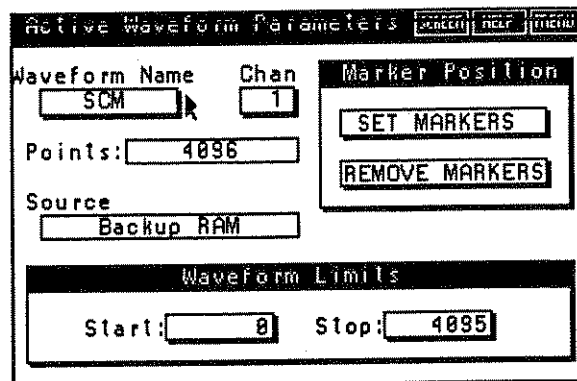

Figure 4-25. Active Waveform Parameters Screen

Waveform or Segment Name

This field displays the name of the current user-defined Waveform or Sequence segment. You may use this field to select any waveform in the current "Source" (see Source: below) to be the "Active" waveform. You can not rename the Waveform from this screen (see "Rename" under the Waveforms Management MENU, or Utilities: Files). For waveforms being Sequenced, the Name field is used to select which waveform segment is to be controlled on the Active screen.

Chan

Displays the Channel number to which the Active waveform information applies. For a multi-channel unit, selecting this field brings up a sub-menu from which you may select any installed channel which is currently running a Waveform or Sequence.

Points:

This field displays the number of horizontal points in the current Waveform. You can not change the size of the Waveform from this screen. However, you can change the size via Waveform: Edit, Resize.

Source:

This field displays the storage location of the selected Waveform. You can not change the source from this screen. To store the Waveform in another location, use Waveform: Copy or Utilities: Files.

Marker Position

This group of fields defines markers that you can set to identify points in the Waveform. For each Marker set in the Waveform, a pulse is generated coincident in time with the Waveform point for which the Marker was set. These pulses show up at the MARKER OUT POSN BNC for the selected channel. When a Waveform is created with the Editor, it is defined and Stored in "equation format". The Markers are not stored with the equation format Waveform, but they can be stored as part of a stored setting (see Instrument Screen). Initially, you can Set as many markers as there are points in the Waveform. However, the Model 295 stores only 15 markers as part of a stored setting. If you need to define more than 15 Markers for your Waveform, you can get around this limit by using Copy Waveform (under the Waveform Screen Menu) rather than usual End Edit and Store (see Edit Waveforms). The Copy causes the waveform data to be saved as a "binary" file, containing all current Markers.

To mark a position, select SET MARKERS from inside the Marker Position field. This brings up the SET MARKERS dialog box as shown in Figure 4-26. Set your position markers by choosing the start address of a sequence of markers and entering this address into the "From" field. Enter the length of the marker sequence into the "Length" field. Then enter the marker sequence as a pattern of "1s" and "0s" (up to 40 characters**). When satisfied, select SET to install the pattern of Markers and then go on to set up another pattern of Markers, or select DONE to install the Markers and quit the SET MARKERS screen.

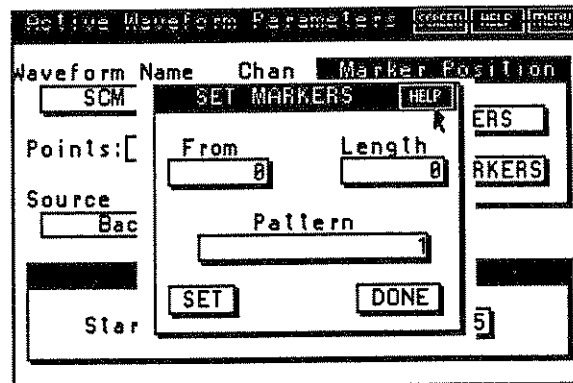

Figure 4-26. Set Waveform Markers Screen

** The pattern will be repeated from left to right as necessary to fill the number of Markers specified in the "Length" field. The default pattern is a single "1", which will set Markers for every point beginning at the address set in the "From" field, for the number of points set in the "Length" field.

To remove Markers, select REMOVE MARKERS from inside the Marker Position field. This brings up the REMOVE MARKERS dialog box as shown in Figure 4-27. Remove a Marker or series of Markers by setting the start address of the Marker(s) in the "From" field and the length of the series in the "Length" field. When satisfied, you can select REMOVE to delete this group of Markers and then go on to select other Markers which you want to remove from the Waveform, or select DONE to delete the selected Markers and quit the screen.

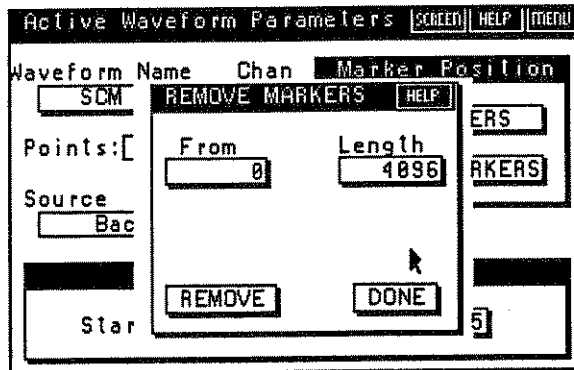

Figure 4-27. Remove Waveform Markers Screen

Waveform Limits

Waveform Limits lets you run a subset of the current Waveform by selecting the Start and Stop address. Initially, the entire Waveform is selected, with the "Start:" field set to zero and the "Stop:" field set to the waveform size (Points:) minus one. The difference between the Start and Stop limits must be at least five points.

Channel Memory

Selecting "Channel Memory" from the Active Waveforms sub-menu brings up the Channel Waveform Memory screen (Figure 4-28). This screen allows you to see which user-defined Waveforms or Sequence segments are currently "Loaded" in a selected Channel's waveform RAM. The RAM memory used per Waveform and total memory usage is shown. There are also buttons to delete selected Waveforms or all active Waveforms listed in the channel memory.

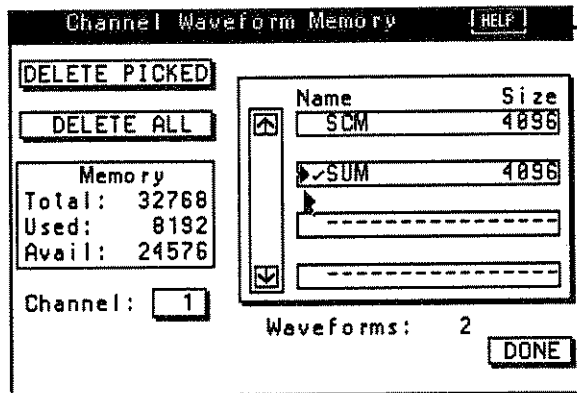

Figure 4-28. Channel Waveform Memory Screen

The list of Waveforms in Figure 4-28 includes all those present in Channel memory. This is true even for Waveforms not currently "Active" (the currently selected user-defined Waveform or a segment of the currently running Sequence).

If more than one Channel is installed, selecting "Channel:" allows you to select any installed channel from a pop-up menu. From the list of names, you can select any Waveform, which puts a check mark (✓) in front of the Waveform name. The selected Waveform(s) may then be deleted from Channel RAM using the DELETE PICKED or DELETE ALL "buttons". If you DELETE the Waveform that is currently "Active", the channel reverts to the Sine Function. If you DELETE an Waveform that is one of the segments of the currently "Active" Sequence, the channel output becomes undefined.

Load Waveforms

Load lets you select an existing Arbitrary Waveform to load into an Arb Channel's waveform RAM and run the waveform. When you select Load the Model 295 switches to the Channel Setup screen with the Function menu displayed; see figure 4-29. From the Function menu, select Waveforms which displays the Waveform Catalog; figure 4-30.

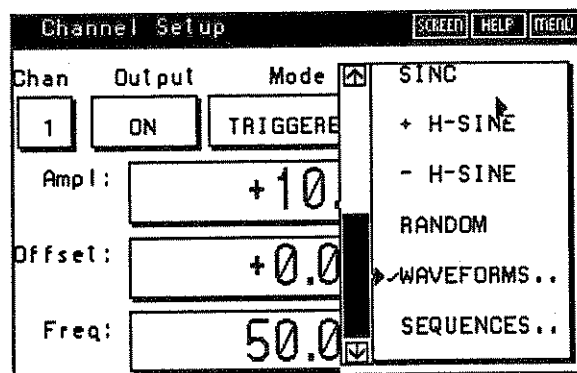

Figure 4-29. Channel Setup Screen

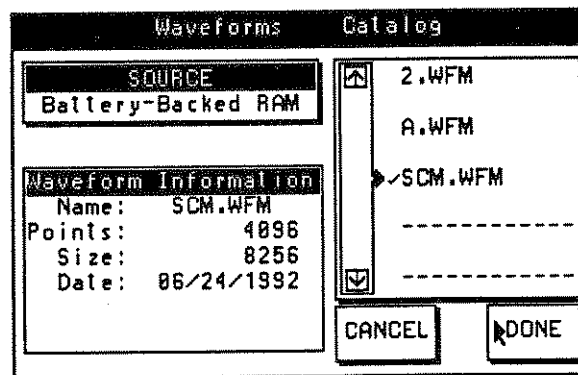

Figure 4-30. Waveform Catalog

From the Waveform Catalog select SOURCE which displays the source list:

Disk Drive (if installed),
 Battery-Backed RAM,
 Current Channel's waveform RAM.

After selecting a source, the a list appears displaying the waveforms stored in that source. Select a waveform from the list. A check (✓) identifies the selected waveform. The INFORMATION block displays the selected waveform's name, number of points, and storage size in bytes.

Select DONE to load the Waveform. Select CANCEL to return to the Waveform Menu screen.

NOTE: When a waveform is loaded into a channel's RAM, it will stay there until deleted. If a channel's RAM is too full to load another waveform, a message will be displayed. You will then need to delete waveforms from the current channel in order to load more. Use the Waveforms:Active:Channel Memory screen or the Waveforms:Delete menu choice.

Loading Waveform Files from the Disk Drive

The Model 295 can Load from DISK Waveforms previously stored by the instrument as *.wfm files. In addition, the following import files are supported:

Using WaveForm DSP™

From within WaveForm, create the desired waveform to be downloaded. In this case the download will be to a file and placed on a floppy diskette to be uploaded by the Model 295, rather than the usual direct GPIB transfer. The 295 cannot upload (as a file) the usual *.wfm format generated by WaveForm for a GPIB download. It can read a *.arb file generated when WaveForm saves to a file. To save the *.arb file on a floppy diskette, select Setup Download from the WaveForm Options menu. Then select Destination:File, which brings up a dialog box to name the file and select its destination. As an example, assume you have a DOS formatted 3 1/2 inch diskette, your 3 1/2 inch drive letter is "B:", and you want to call the waveform you've created "ANA". For this example, you would install the floppy in drive b, select Directories: [-b-], and the type "ANA.arb" in the Filename. Press "OK" to close the dialog. Be sure to select Model:Model 295-32(128)K and Trace:CH<n> - Waveform, where "n" is your channel number. The remaining defaults are generally acceptable. Select "OK" to close the Setup Download dialog and then select Exec Download from the I/O menu.

The file "ANA.ARB" is now on the floppy diskette. Transfer the floppy diskette to the Model 295 disk drive, and follow the procedure above to transfer the file from the Waveform Catalog screen, Source set to Disk Drive, to the selected channel's waveform storage RAM. Once the waveform is loaded, it can be copied from the current channel to the Model 295 Battery-Backed RAM (see Waveform:Copy).

Using a Spreadsheet Application or ASCII File

The Model 295 can also read files created with most spreadsheets or an ASCII test editor using MSDOS compatible file format. In this case the filename *must have an extension of .wft* for the 295 to recognize it as a waveform text file. The format of the ASCII file must be as follows:

The file must contain a list of numbers separated by any non-numeric characters (spaces, tabs, commas, text, . . .). The first number in the file specifies the number of points in the waveform. There must be at least that many numbers remaining in the file which represent the data values of each point in the waveform. Data values range from "1" to "4095", where "1" is the most negative point in a waveform, and "4095" is the most positive.

Position Markers can be part of the waveform data. For each point which is to have a Position Marker set, add "16,384" to the data value.

Edit Waveforms

The Edit screen allows you to select and edit any existing Waveform. To begin editing a Waveform, select Waveform via the SCREEN field or press the WAVEFORM key. When the initial Waveform screen appears, select EDIT to display the Waveform Catalog; see figure 4-31.

Waveform Catalog

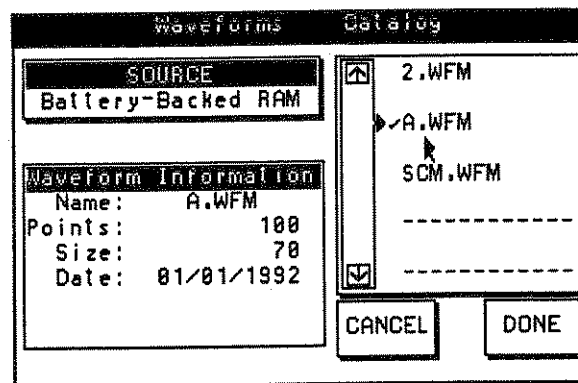

Figure 4-31. Waveform Catalog

From the Waveform Catalog select SOURCE which displays the source list:

- Disk Drive (if installed),
- Battery-Backed RAM.
- Current Channel's waveform RAM.

After selecting a source, the a list appears displaying the waveforms stored in that source. Select a waveform from the list. A check (✓) identifies a selected Waveform.

Select DONE to accept the Waveform and advance to the Information Message. Select CANCEL to return to the Waveform Menu screen.

Information Message

This Information message, see figure 4-32, tells you how to connect the Model 295 to the oscilloscope. It describes the Model 295 to scope interconnections plus the vertical and horizontal (sweep time) scope settings. See figure 4-33.

*Connect the Arb Channel's Main Out to the scope's CH 1 input.
Connect the Arb Channel's Sync Marker output to the scope's Trigger input. Properly terminate both the Main Out and Sync Markers cables with 50Ω terminations. Connect the Model 295*

System Z-Axis Out to the scope's Z-Axis input. To set the Z-Axis intensity for your scope, see Waveforms Menu: Z-Axis.

After connecting the Model 295 to the scope and making the scope settings select BEGIN EDIT to advance to the Waveform Scope Edit screen. Selecting CANCEL EDIT returns the Model 295 to the Waveform Menu screen.

When the Model 295 is in an Editing mode, it will set the channel amplitude, offset, and sample rate to default values. This setup will provide an optimum trace frequency on the oscilloscope for ease of editing.

If you know what the setup for your Waveform is going to be, you can use the Menu option "Units" to program these settings (see Menu:Units).

CAUTION

Failing to set up the scope as described above could cause difficulty while editing the Waveform.

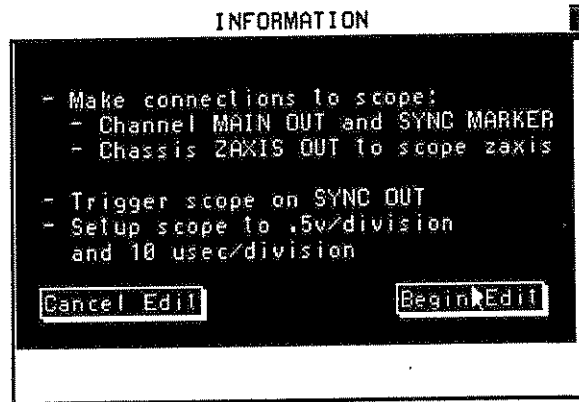

Figure 4-32. Information Screen

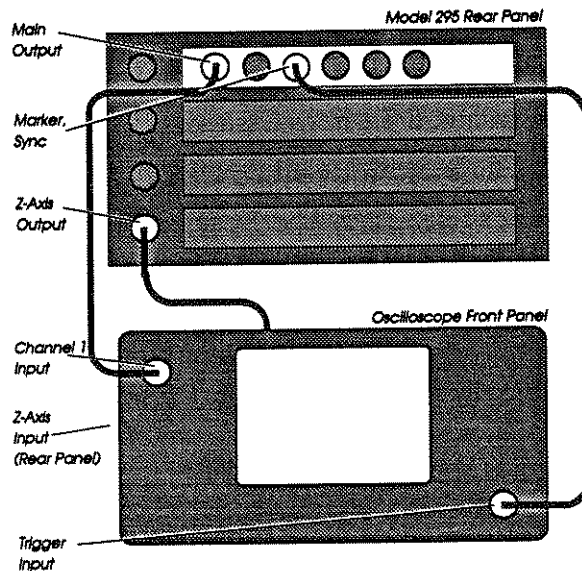

Figure 4-33. Waveform Edit Setup

Scope Edit Screen

The Scope Edit screen is the screen you work from while creating and editing an Arbitrary Waveform. From this screen, select the "tools" you want to use to edit the Waveform. For example, you can insert a math equation, draw a line, change points, or sketch using freehand. In addition, you can use vertical move, vertical resize, copy, delete, and insert to change portions of a Waveform. Another tool, zoom, gives you a closer look at a portion of the Waveform.

When using the Waveform Scope Edit screen, there are two cursors that you can control - the LCD cursor on the Model 295 front panel, and the Waveform Cursor at the oscilloscope. To toggle control between these two cursors, press the right mouse button or the LCD/SCOPE key on the front panel. After you select certain editing tools (freehand-draw, line-draw, Vertical Move, and Vertical Resize) the control automatically switches to the Waveform Cursor at the oscilloscope.

Figure 4-34 illustrates the Waveform Edit screen. The following text describes elements of that screen.

Name: SCM		chan:1	Points:4096
CURSOR	address	absolute 0	relative 0.0000 sec
	data	+0	+0.000 V
BLOCK	start	0	0.0000 sec
	length	+1	+20.00 nsec
	height	+0	+0.000 Vpp
Math	VertMov	Delete	Zoom
FreeHnd	VertRsz	Copy	Unzoom
LineDrw	Mirror	Insert	LineList

Figure 4-34. Waveform Edit Screen

Waveform Name

This item displays the name of the Waveform. This screen does not allow you to change the name. Use the *Utilities: Files* screen to rename this Waveform.

Points

This item displays the number of points in the Waveform. Resizing the Waveform changes the number of points: see *Menu: Resize*.

Cursor Address and Data

This item displays the scope cursor address, X value, and cursor data, Y value. The screen displays the position value in both absolute units and relative units. Absolute units represent the "address/data" points of the Waveform. Minimum cursor position is 0000 representing the first point in the Waveform. The maximum point depends on the number of points in the Waveform. Cursor data represents the Y value at that cursor address. For convenience, the Model 295 also displays the cursor's relative position and value in time (seconds) and amplitude (Volts). The Waveforms MENU button, "Units" selection defines the units values used on this screen.

There are two ways of changing the cursor position. First, use the right

Math - Triangle

Triangle replaces the block with a triangle function between the block's start and stop points (X values). Figure 4-35 - Function Expression: Triangle defines the triangle expression syntax:

Tri(##,##)

Where the first # represents the number of cycles in the block. The second # represents the duty cycle (0 to 100%) of the function. Notice a comma separates the two values.

For example, Tri(2,50)*.25 produces two symmetrical triangles with an amplitude of 1/4 of full scale; see the following Waveform.

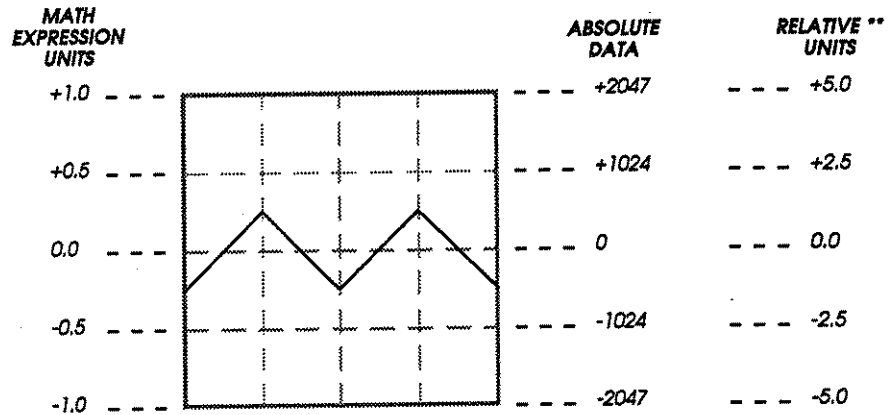

Math - Pulse

Pulse replaces the block with a pulse or square function between the block's start and stop points (X values). Figure 4-35 - Function Expression: Pulse defines the pulse expression syntax:

Pul(##,##)

Where the first # represents the number of cycles in the block. The second # represents the duty cycle (0 to 100%) of the function. Notice a comma separates the two values.

For example, Pul(5,25)*.5 +.5 produces five 25% duty cycle pulses with an amplitude from zero to positive full-scale; see the following Waveform.

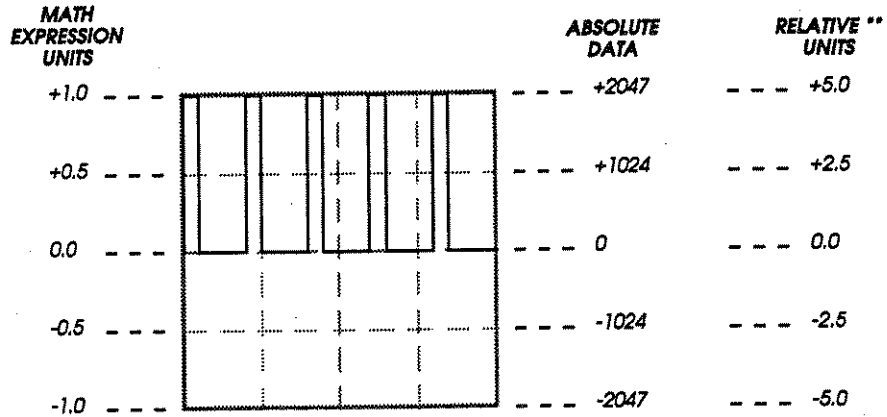

Math - Tangent

Tangent replaces the block with a tangent function which the Model 295 normalizes at 87°, 267°, and 273° to equal ±1 instead of ~20. Figure 4-35 - Function Expression: Tangent defines the tangent expression syntax. "T" represents one cycle (360°) of the function. For multiple cycles, use "*"#" in the expression. Plus, "+#" or "-#" represents the phase shift of the expression where a value of 1 represents 100% (360°) of the cycle.

For example, Tan(T) produces one cycle of a tangent function; see the following Waveform.

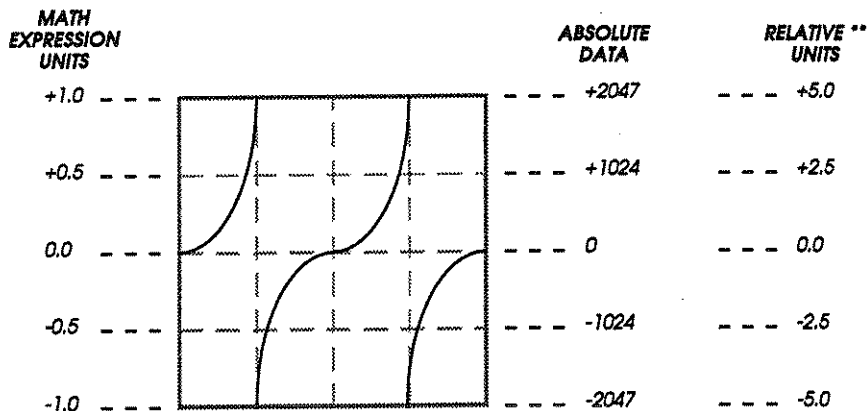

Math - Exponential

Exp replaces the block with an exponential function using values between 0 and 3 which the Model 295 normalizes as -1 (0) and +1 (3). Figure 4-35 - Function Expression: Exp defines the exponential expression syntax. "T" represents one "cycle" (100%) of the function. For multiple "cycles", use "*"#" in the expression. Plus, "+#" or "-#" represents the phase shift of the expression where 1 represents a full "cycle."

For example, Exp(T*2.5) produces 2-1/2 "cycles" of an exponential function. See the following Waveform.

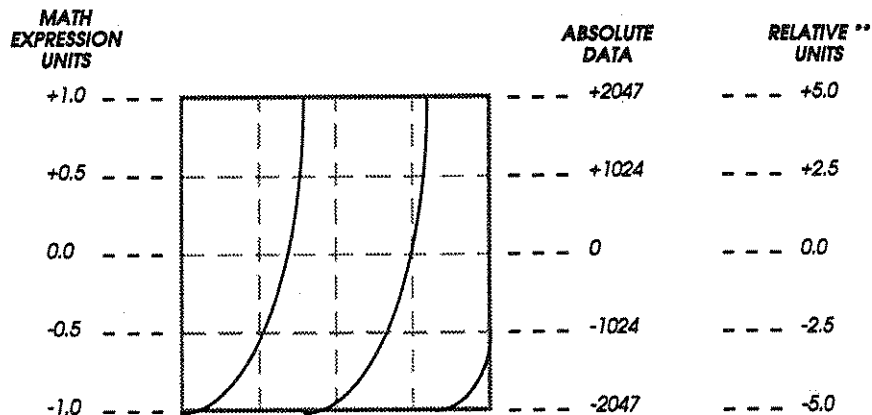

Vertical Resize

Vertical Resize allows you to change the peak to peak amplitude of a block. A block resized smaller could lose some waveform resolution when enlarged.

To resize a block,

Select a block (see Block Selection).

Select VertRsz on the Scope Edit screen. The Model 295 automatically switches control of the cursor back to the scope.

Highlighted horizontal blocks identify the selected block. Moving the mouse up or down resizes the block.

Clicking the right mouse button returns to the LCD cursor on the Scope Edit screen.

Delete

Delete erases Waveform blocks. Deleting a block adds the same number of points at the end of the Waveform.

To delete a block,

Select a block (see Block Selection).

Select Delete on the Scope Edit screen. The Model 295 immediately erases the block.

Copy

Copy duplicates a selected block of the Waveform. Use Insert to insert the copied block in the Waveform.

To Copy a block,

Select a block (see Block Selection).

Select Copy from the Scope Edit screen to copy the block.

Insert

Insert a copied block into a Waveform. The Model 295 inserts the block at the cursor. You can insert a block into a Waveform as many times as needed.

To Insert a block,

Select the insertion point by clicking the right mouse button to select the scope. Position the cursor at the insertion point and click the left mouse button. Click the right mouse button to return to the Scope Edit screen.

If you accidentally select a block, don't worry. The first point of the block is always the cursor (insertion) point. In fact, selecting a block (double-clicking) is a good method of inserting a block at the end of another block.

Select Insert on the Scope Edit screen. The Model 295 immediately inserts the block.

Zoom

Zoom magnifies a block of the Waveform on the scope. The defined block fills the entire scope display. You can magnify a block as many times as needed. The minimum block size for Zoom is a five point block. Use Unzoom to return to the original sized trace.

Caution

If you do not set the scope's time base as listed on the Information screen, the Zoom tool will not function properly.

To Zoom,

Select a block (see Block Selection).

Select Zoom on the Scope Edit screen. The block fills the scope's display.

Unzoom

Unzoom returns a Zoomed block to its original trace size.

To Unzoom,

Select Unzoom on the Scope Edit screen. The Waveform fills the scope's display.

Line List

Line List provides a method to easily create trapezoidal (series of line segment) waveforms by entering a list of vertices directly from the front panel without using the waveform cursor on the oscilloscope (such as the Line Draw tool requires).

To use Line List (an example follows on the next page),

Select the Line List tool. Some waveform cursor and block values on the Scope Edit screen are "dashed out".

Change the Cursor Address to the desired address of the first vertices. "Anchor" the vertex by entering the desired Cursor Data value.

Repeat entering address and data values for each vertices.

Select the List Done button when done.

Point Editing

Point Edit allows the changing of a single point in the Waveform. Unlike other edit functions, point edit only can be done via the Scope Edit screen. In order to see a single point on the scope trace, you may have to use the Zoom tool.

To edit a single point, select the CURSOR: address field. Use the mouse or keypad to select the point's address value. Next select the CURSOR: data field and use the mouse or keypad to change the value of the point.

Line List Example

Following is an example editing procedure you may use to create the waveshape shown below.

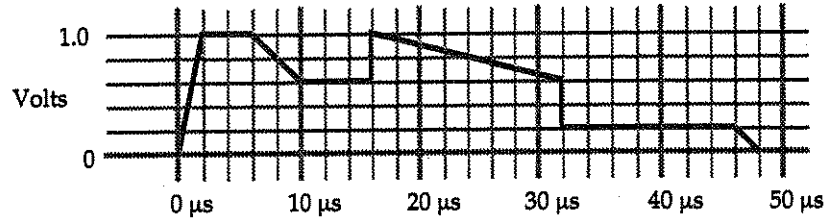

Line List Example

1. First determine the sample rate and number of points required to adequately reproduce the waveshape. A simple approach to this is find the highest frequency component within the waveshape, and decide how many points are required to reproduce it. The sample frequency is then the quotient of the number of points in the component and its period. Then extrapolate the total number of points required for the whole waveshape.

In this example, the line from (0 μs, 0V) to (2 μs, 1V) is the fastest component. The vertical transitions do not have to be considered; their "shape" can be fully defined with a single point. Assume that you are satisfied with 50 points for this component. The sample rate will then be 50 points/2 μs = 25 MHz. The total number of points is then 48 μs x 25 MHz = 1200 points.

2. Press the Waveform key and choose "New" from the MENU. Enter the name of the waveform and select the number of points as 1200. At the Scope Edit screen select the MENU button, "Units" selection. Set Amplitude = 1Vp-p, Offset = .5V, and Sample Rate = 25 MHz. By setting up the relative units accordingly, you can define the waveshape above directly in relative units of volts and seconds, rather than having to deduce the absolute address and data values. Close the MENU.
3. Select the Line List tool. Enter the following numbers (in the order shown) in the *relative* column for cursor address and data values:

Address	Data
0	0
2e-6	1
6e-6	1
10e-6	.6
16e-6	.6
16e-6	1
32e-6	.6
32e-6	.2
46e-6	.2
47.96e-6	0

4. Select Line Done to complete the line list entry.

Scope Edit Menu "Button"

Select the Scope Edit Menu "button" (or the dark gray key adjacent to the MENU button at the upper right corner of the screen) to perform supplemental tasks related to Waveform editing. See figure 4-36.

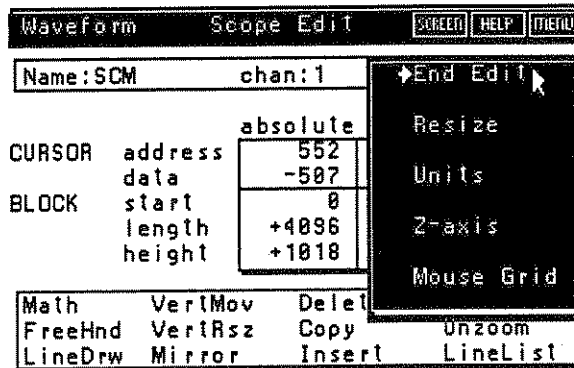

Figure 4-36. Scope Edit Menus

End Edit

Select End Edit from the Waveform: Menu button allows you to store the Waveform. Selecting End Edit displays the Waveform Storage screen. Figure 4-37 illustrates the Waveform Storage screen and the following paragraphs describes the items on this screen. The Model 295 stores all Waveforms in compressed format whenever possible.



Figure 4-37. Waveform Storage Screen

Store on Disk

Store on Disk stores the current Waveform to the disk. The diskette must be formatted. See Utilities, MENU button, Files: Format.

To obtain the amount of space available on the floppy diskette, press the Utilities key, select "Files" from the MENU, and choose

the menu item "Disk: Get Info".

Store in Battery-Backed RAM

Store in Battery-Backed RAM stores the current Waveform to the Model 295's battery-backed RAM. The waveform will also be located in the Channel's RAM (volatile). To read the amount of RAM used and available, see Utilities MENU, "Files", menu item "RAM: Get Info".

Keep But Don't Store

The waveform is retained in the Channel's RAM from which it can be run as the Channel's function. It can also be copied to disk or Battery-Backed RAM at a later point.

NOTE: If power is cycled to the Model 295, this copy of the waveform in the volatile Channel RAM will be lost.

Discard

Discard ends Waveform Editing without saving the Waveform. It also deletes the waveform from the Channel's RAM.

And Rename

"And Rename" changes the name of the Waveform before storing it. Selecting "And Rename" displays the Waveform Name screen; figure 4-38.

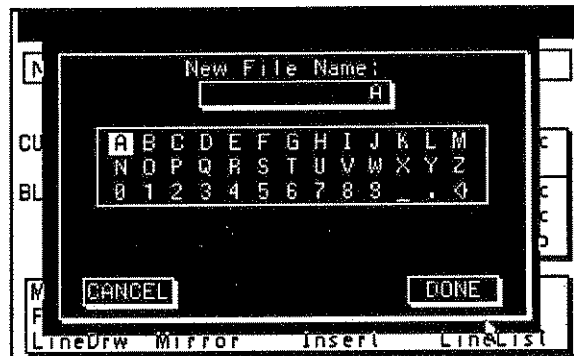

Figure 4-38. Waveform Name Screen

Waveform names can contain from one to eight characters. Use the mouse to select characters from the Character Set. As you select different characters using the mouse, the name in the Name Box advances from right to left. Or, use the up and down arrow keys to scroll through a character set (displayed in the Name Box). Use the left arrow key to accept the character and move to the next position. Use the CLEAR key to erase the entire name. To erase individual characters, use the BSP (backspace) key. Initially the screen displays the old name. When finished select DONE to save the waveform with a new name. If the new name exists, the Model 295 warns you. Selecting CANCEL returns to the End Edit screen.

Resize

Resize changes the number of points in the current Waveform. When selected, the Waveform Resize dialog box appears. Figure 4-39 illustrates the Waveform Resize dialog box and the following text describes each function.

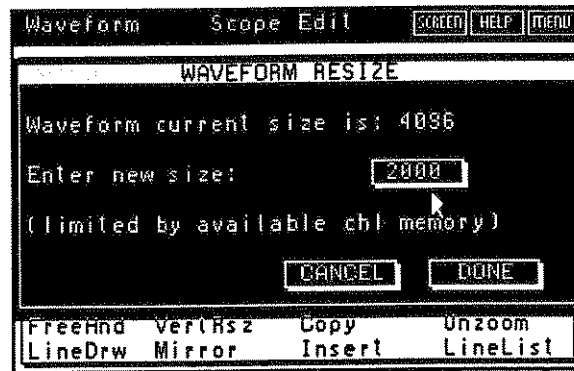

Figure 4-39. Waveform Resize

Current Number of Points

This box lists the number of points in the current Waveform. This value cannot be changed.

New Number of Points

Select this box to change the total number of points in the Waveform. Entering a number less than the waveform current size truncates the Waveform by that number of points. The points cut off are lost. Entering a number greater than the waveform current size extends the Waveform by that number of points.

Done

Select DONE to resize the Waveform.

Cancel

Select CANCEL to exit Waveform Resize and revert to the original Waveform.

Units

Selecting Units allows you to change the units of measure displayed on the Scope Edit screen in the Relative Units column for the waveform cursor and block data. Changing units does not alter the Waveform's operating parameters. It does change the units displayed on the Scope Edit screen. This permits you to set up values relative to your actual operating parameters. Figure 4-40 illustrates the Units screen and the following text describes each function.

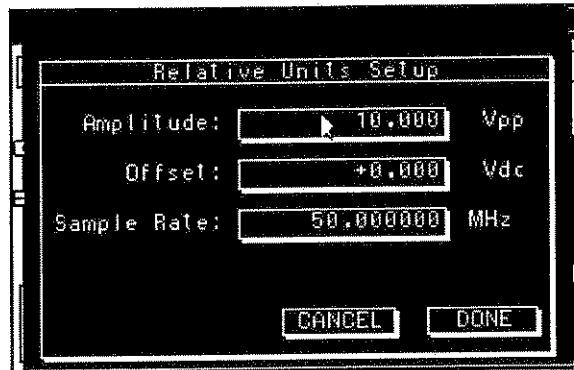

Figure 4-40. Units Screen

Amplitude

Select the Amplitude field to change the Waveform's voltage (Vp-p only) displayed on the Scope Edit screen. Use either the mouse or keypad to change the value.

Offset

Select the Offset field to change the Waveform's relative dc offset voltage displayed on the Scope Edit screen. Use either the mouse or keypad to change the value.

Sample Rate

Select the Sample Rate field to change the Waveform's relative sample rate displayed on the Scope Edit screen. Use either the mouse or keypad to change the value.

Done

Select DONE to change the Scope Edit screen's units of measure.

Cancel

Select CANCEL to return to the previous setting of the Scope Edit screen's units of measure.

Z-Axis

Z-Axis Control (figure 4-41) sets up the Model 295 Z-Axis Output to match your scope. Check the specifications for the scope you are using for the correct Z-Axis setting. Use either the slider box or value field to set the Z-Axis level. Select the Polarity field to toggle between Positive and Negative logic sense. Vary the Z-Axis level between 0 and 255. These values represent 0 to +9.4V in 40 mV steps.

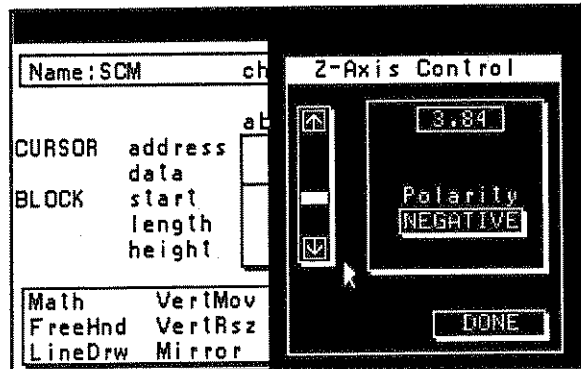

Figure 4-41. Z-Axis Control Screen

To adjust the Z-Axis control for your scope,

Connect the Model 295 and scope as shown in figure 4-33.

Select Z-Axis from the Scope Edit Menu "button".

Select the proper polarity for your scope. Move the "Slider" up or down for the best intensity of the block.

Select DONE when the intensity is correct. The Model 295 stores the Z-Axis setting.

Mouse Grid

By default, the waveform cursor can be moved horizontally and vertically with single point resolution. The "Mouse Grid" MENU selection is provided to change this resolution. This is useful in selecting a block of points in a waveform and when using the LineDraw tool. Set the Mouse Grid resolution as follows:

1. Determine the required offset, amplitude, and sample rate for the waveform (see the Line List example). Select "Units" from the MENU and set these values.
2. Determine the resolution of mouse movement required to place the mouse at any waveform "vertices" (point of deflection). Select "MouseGrid" from the MENU and set this value. Use the *relative* units column if the "Units" have been set up.

Copy Waveforms

Copy (Waveform Management Menu) allows you to duplicate an existing Waveform. You must give the copy a new name, a new destination, or both. Copying Waveforms provides a simple method of altering existing Waveforms without destroying them.

"Copy" also provides you with the means to store waveforms with their Markers, not restricted by the 15 Marker limit. A Waveform created with the Waveform Editor is stored in equation format along with a list of Markers, up to 15. Selecting and copying a Waveform from the current Channel to DISK or Battery-Backed RAM converts it to binary format, where a Marker is just part of the point data.

When Copy is selected the Waveform Catalog appears. From the Waveform Catalog, select the Waveform you want to copy. Next, select DONE to advance to the Waveform Name screen; see figure 4-42.

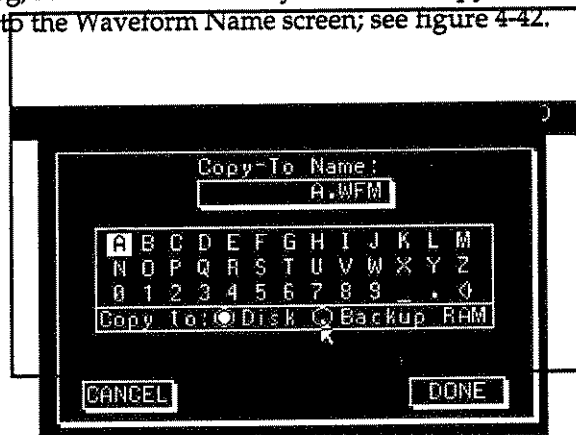

Figure 4-42. Waveform Name Screen

Use the mouse, arrow keys, or keypad to enter the new name. This screen also asks you to select the destination (storage location) for the copied Waveform:

Disk Drive (if installed),
Battery-Backed RAM.

After entering the name and selecting the destination, select DONE to copy and name the Waveform. Selecting CANCEL returns to the Waveform Menu screen without copying the Waveform.

Waveforms also can be copied via the Utilities, Files menus.

Delete Waveforms

Delete (Waveform Management Menu) allows you to remove waveforms stored on disk, battery backed RAM, and current channel's waveform RAM. Use Delete when a channel's RAM is too full to load a desired waveform. Deleting a running waveform on the current channel forces the channel's function to Sine. Waveforms can also be deleted via Utilities: Files.

Selecting Delete displays the Waveform Catalog; see figure 4-43 and its following text. Select the Waveform you want to delete.

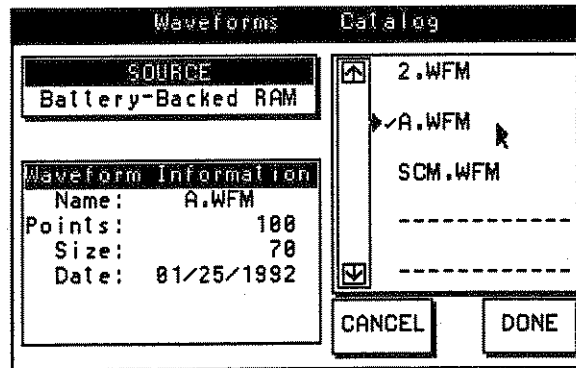

Figure 4-43. Waveform Catalog

From the Waveform Catalog select SOURCE which displays the source list:

Disk Drive (if installed),
 Battery-Backed RAM,
 Current Channel RAM.

After selecting a source, the LISTING displays the Waveforms stored in that source. Select a Waveform from the listing. A check (✓) identifies the selected Waveform.

Selecting DONE advances to the Warning screen; see figure 4-44. Selecting CANCEL from the Waveform Catalog returns to the Waveform Menu screen without deleting the selected Waveform.

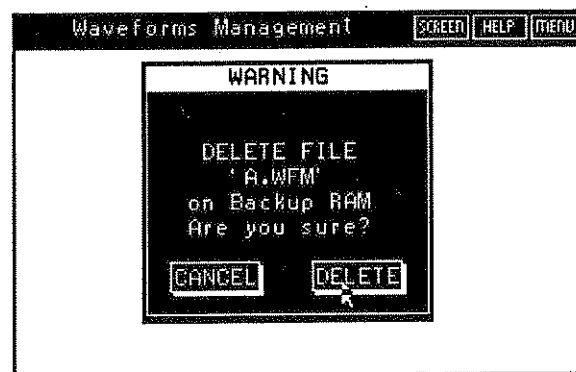

Figure 4-44. Warning Screen

Select DONE to delete the Waveform. Select CANCEL to return to the Waveform Menu screen without deleting the selected Waveform.

You can delete Waveforms via the Utilities, Files menus.

New (Create) Waveforms

New creates custom Arbitrary Waveforms. You can use Waveforms separately or as part of a Sequence. Once created, a Waveform can be copied, deleted, and edited.

Before Starting

Before beginning to create a new Waveform, there are several points to think about.

How many points should the Waveform contain? See the Waveform Name screen.

What will be the Waveform's sample rate, amplitude, and offset? See the Scope Edit screen and the Menu "button" Unit's screen.

To create a new Waveform, select Waveform. You can use either the SCREEN "button" or WAVEFORM key. Selecting New displays the Waveform Name screen. See figure 4-45.

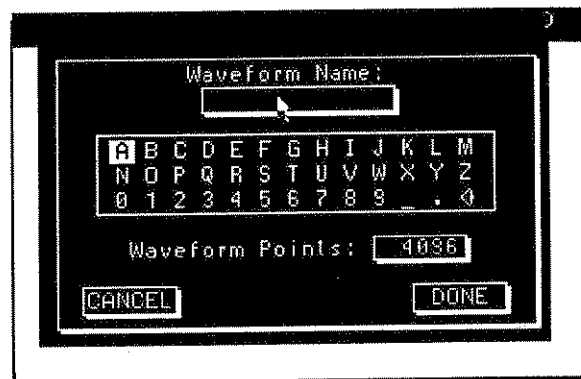

Figure 4-45. Waveforms Name Screen

Waveform Name

Use the Waveform Name screen to name the new Waveform. Use this name to identify the Waveform in catalogs and listings. The Model 295 automatically appends the Waveform name with ".WFM" for Waveform. Also this screen defines the initial number of points for the Waveform.

Waveform names can contain from one to eight characters. Use the mouse to select characters from the Character Set. As different characters are selected, the name in the Name Box advances to the left. Also use the up and down arrow keys to scroll through a character set (displayed in the Name Box). Use the left arrow key to accept the character and move to the next entry. Use the CLEAR key to erase the entire name. To erase individual characters, use the BSP (backspace) key.

Select the Waveform Points field to define the number of points in the Waveform. Use the keypad to enter the new value as well as the mouse or up /down arrow keys. The minimum number of points in a Waveform is five points. The maximum number of points depends on the amount of free memory available on the Arb Channel board. The default number of points normally will be 4096 points. The Waveform Points field displays the amount of free memory if less than 4096 points is available. If you enter a

value greater than the available memory, the Model 295 displays an Error message. To clear Waveforms from memory use Delete Waveforms and set the source to the current channel or go to the Waveforms:Active:Channel Memory screen.

When finished naming the Waveform, select the DONE button to advance to the Information Screen. Select the CANCEL button to terminate the new Waveform.

Information and Scope Edit Screens

The remaining screens used to create new waveforms are identical to those used to edit existing waveforms. The following list references paragraphs detailed in previous portions of this section.

Information Message	Page 4-35
Scope Edit Screen	Page 4-37
End Edit	Page 4-49
Resize	Page 4-5
Units	Page 4-52
Z-Axis	Page 4-53

SEQUENCE

A Sequence links together from two to four Waveforms. Each waveform has its own loop and advance conditions. The Model 295 contains a series of screens for Sequence setup, editing and use. Select Sequence via the SCREEN field or press the SEQUENCE key to get to the Sequence Management screens. See Figure 4-46. The following paragraphs will guide you through the Sequence Setup Screens starting from the Main Sequence Management screen.

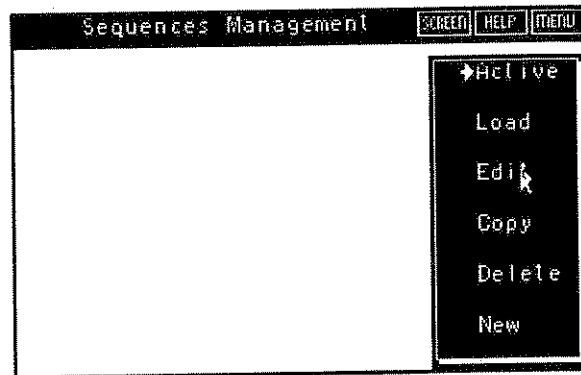

Figure 4-46. Initial Sequence Screen

Active Sequence

The Active screen displays information about the currently running Sequence. The screen, which is named Sequence Information, displays a warning if the current Arb Channel is not running a Sequence. This screen does not display the selected Arb Channel. Figure 4-47 illustrates a typical Active (Sequence Information) screen. Several of the fields in the figure can be edited, changing the parameter of the Sequence running in the Channel RAM. However, these changes do not effect the copy of the Sequence stored in Battery-Backed RAM or disk. To store changes made to the Active Sequence using this screen, open the Sequence Edit screen and then select "End Edit" from the Edit screen's menu. The following text describes items on the Active Sequence screen.

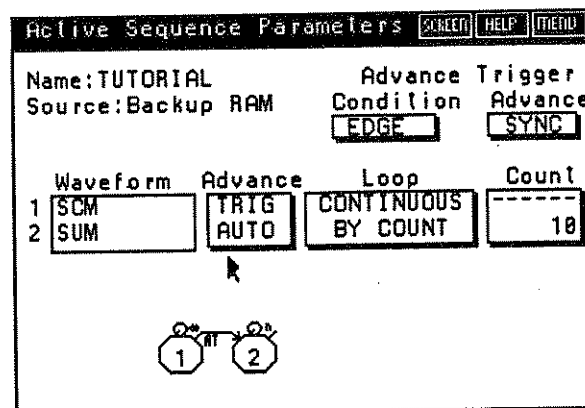

Figure 4-47. Active Sequence Parameters Screen

Sequence Name

This field displays the name of the current Sequence. You can not select another Sequence from this screen. See Sequence: Load or Channel Setup: Function, Sequence to select another Sequence. You cannot rename this Sequence from this screen. To rename this sequence, use the Sequence; End Edit or Utilities: Files.

Source

This field displays the storage location of the selected Sequence. You cannot change the source from this screen, To store the Sequence in another source, use Sequence: Edit, End Edit or Utilities: Files.

Advance Trigger

This item has two "buttons", "Condition" and "Advance", which display and allow editing of the conditions under which a segment will branch to the next segment in the Sequence when its "Advance" field is set to TRIG. "Condition" is set to either EDGE or LEVEL, and selecting the field will cause a pop-up menu to appear to allow editing of the active Sequence. Likewise, "Advance" may be edited to either SYNC or ASYNC. These terms are defined under the Edit Sequence Menu, Adv Trig later in this section.

Waveform

This field displays a list of the segments in the current Sequence. This field only displays the names of the Waveform segments, which can not be edited in the Active screen (see Edit Sequence).

Advance

The "Advance" field will display either TRIG or AUTO for each segment. Selecting one of these fields will bring up a pop-up menu where you may alter your selection for that segment (see Edit Sequence).

Loop

The "Loop" field will display either CONTINUOUS or BY COUNT for each segment. Selecting one of these fields will bring up a pop-up menu where you may alter your selection for that segment (see Edit Sequence).

Count

The "Count" field will be "dashed out" for any segment with its "Loop" field set to CONTINUOUS. If the "Count" is set to BY COUNT, this field will display the current repeat count for that segment in the Active Sequence. This value can be edited (see Edit Sequence).

Load Sequence

When you select Load the Model 295 switches to the Channel Setup screen with the Function menu displayed; see figure 4-48. From the Function menu, select Sequence displaying the Sequence Catalog; figure 4-49.

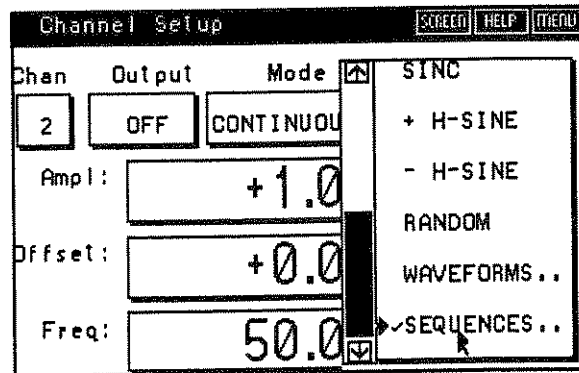

Figure 4-48. Channel Setup Screen

From the Sequence Catalog select SOURCE which pops up the source list:

Disk Drive (if installed),
Battery-Backed RAM.

After selecting a source, the LISTING displays the Sequences stored in that source. Select a Sequence from the listing. A check (✓) identifies the selected Sequence. The INFORMATION screen displays the Sequence's name and segments.

Select DONE to accept the Sequence. Select CANCEL to return to the Sequence Menu screen.

When a Sequence is "Loaded", the following events will occur:

Each waveform listed in the Sequence is loaded into the current Channel's RAM. The Channel hardware is then programmed to output the waveforms according to the rules listed in the Sequence.

There are two possible conditions which can cause Sequence Load to fail. These are:

1. If a Channel's RAM is too full to load one of the waveforms. You will then need to delete waveforms from the current channel in order to load the Sequence.
2. If one of the waveforms is not found in the same storage location as the Sequence.

In either event, a message will be displayed and the Function Out will become the standard sine wave.

Edit Sequence

The Model 295 allows you to select and edit any existing Sequence. When you edit a Sequence, you can change any or all of the Sequence's segments. To begin editing a Sequence, select Sequence via the SCREEN field or press

the SEQUENCE key. When the initial Sequence screen appears, select EDIT to display the Sequence Catalog; see figure 4-49.

Sequence Catalog

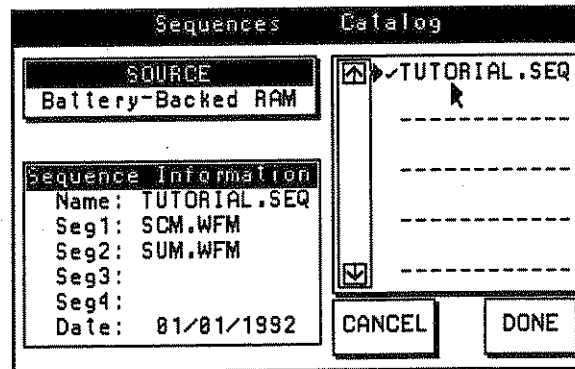

Figure 4-49. Sequence Catalog

From the Sequence Catalog select SOURCE which pops up the source list:

Disk Drive (if installed),
Battery-Backed RAM.

After selecting a source, the LISTING displays the Sequences stored in that source. Select a Sequence from the listing. A check (✓) identifies the selected Sequence. This screen also displays the Sequence's name and segments.

Select DONE to accept the Sequence. Select CANCEL to return to the original Sequence.

Sequence Edit Screen

Use the Sequence Edit screen (figure 4-50) to edit the Sequence. The Model 295 identifies the parts of the Sequence as Segments. Select the items on the Sequence Edit screen by using the mouse or keypad.

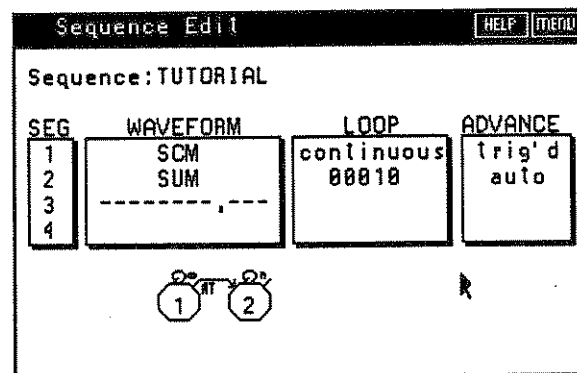

Figure 4-50. Sequence Edit Screen

Sequence Name

The Sequence Name identifies the Sequence now running in the last selected Arb Channel.

Segment Number

Sequence uses Segment Numbers to identify segments in the Sequence. A Sequence can contain up to four segments. A segment consists of the selected Waveform, the Loop type, and the Waveform Advance method.

Waveform Window

This selection lets you pick the Waveform for each segment. When selected, the Waveform Catalog screen appears. Select the Waveform for the segment. See figure 4-51.

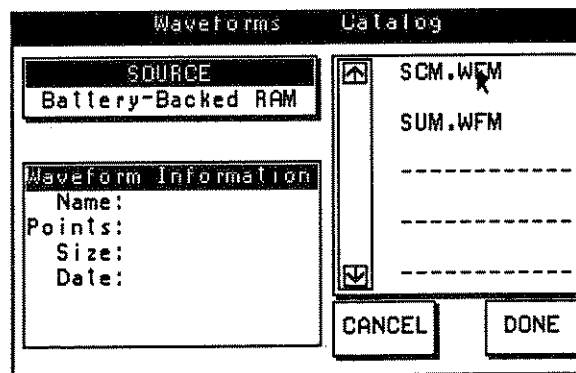

Figure 4-51. Waveform Catalog

From the Waveform Catalog select SOURCE which pops up the source list:

- Disk Drive (if installed),
- Battery-Backed RAM
- Current Channel RAM.

After selecting a source, the LISTING displays the waveforms stored in that source. Select a waveform from the listing. A check (✓) identifies the selected waveform. The INFORMATION screen displays the waveform's name, number of points, and size in bytes.

Select DONE to accept the Waveform and return to the Sequence Edit screen. Select CANCEL to return to the Sequence Menu screen.

Loop Window

From the Loop Window you can define the number of cycles of the Waveform in the segment. The Loop Waveform screen appears after selecting the Loop Window (see figure 4-52).

A waveform can be looped 1 to 65,535 times, or it can be looped continuously. Each loop is a complete pass through all of the waveform points (within the waveform limits - see Waveform Active).

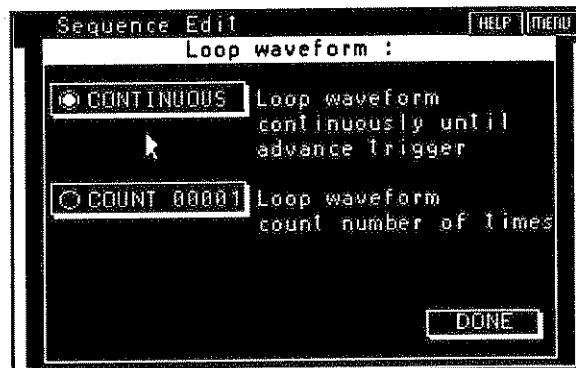

Figure 4-52. Loop Waveform Screen

Continuous

Continuous runs the waveform until receiving an advance trigger.

Count 00001

Selecting Count enters the number of times the waveform is looped. Use the mouse to change the Count. Also, you can select the Count field and use the keypad; use the ENTER key when using the keypad. Counts can be programmed from 00001 to 65,535 counts.

Select DONE to accept the Waveform and return to the Sequence Edit screen.

Advance Window

Selecting the Advance Window defines segment to segment advance conditions. When the Advance Window is selected, the Advance To Next Waveform screen appears. See figure 4-53. Advance sets how one waveform advances to the next after the Loop Count is completed (or immediately if in Continuous loop).

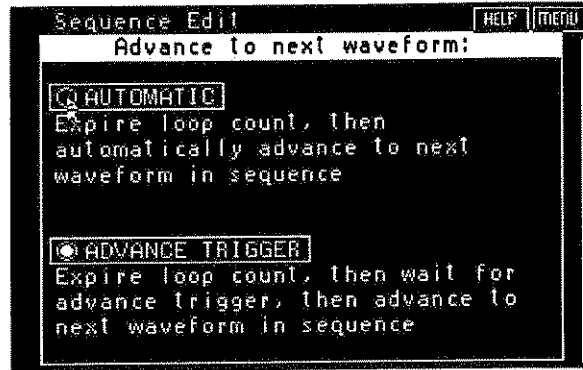

Figure 4-53. Advance To Next Waveform Screen

Automatic

The Loop Count is completed, then the next waveform will automatically begin. Automatic works only with a setup loop count. Selecting Loop Continuous and Advance Automatic (Advance Window) causes an error when attempting to save the Sequence.

Advance Trigger

The Loop Count is first completed (unless it is Continuous), then when the "advance" trigger condition is met, the next waveform will begin.

If the advance from the last segment is advance trigger, then the sequence must run in the continuous mode.

Sequence Edit Screen Graphics

While constructing the sequence, the Waveform Edit screen displays graphics illustrating the components of each segment in the Sequence. Figure 4-54 illustrates a typical Sequence graphics.

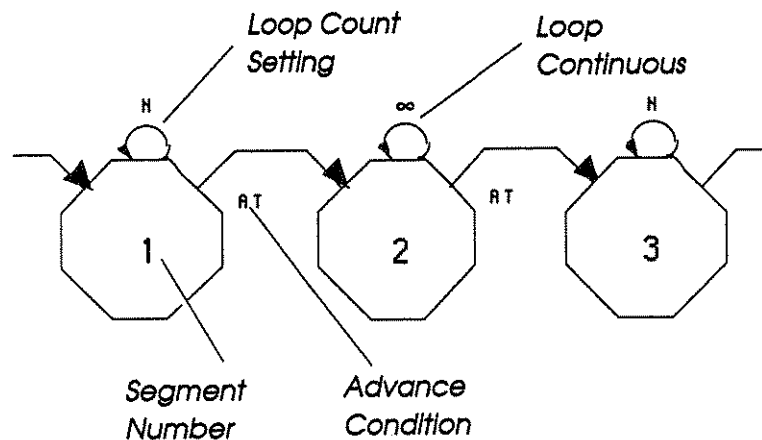

Figure 4-54. Sequence Graphics

Loop Setting

Loop Setting identifies the selected loop condition for the segment. N represents a Loop Count from 2 to 65,535. The graphics does not display the actual loop count value. The infinity symbol, ∞ , represents Continuous Loop. If Loop Count is equal to 1, then no loop symbol appears.

Segment Number

Segment Number identifies the order the Waveform appears in the Sequence. The Waveform name does not appear. The Sequence in figure 4-52 uses only three segments.

Advance Condition

Advance Condition identifies the segments advance condition. "AT" represents Advance Trigger. If "AT" is not displayed, the advance condition is "Automatic".

Adding Additional Segments

Add segments to the Sequence by selecting the Waveform, Loop and Advance conditions from the Sequence Edit screen.

Inserting Segments

To insert a segment between two existing segments, return to the Sequence Edit screen and select a segment number. The next dialog box asks if you want to insert or delete the segment. Select INSERT. The original segment number shifts down one line leaving a blank line for the new segment. Edit the segment by adding the new Waveform, Loop, and Advance conditions.

Caution

If four segments exist in the Sequence, selecting INSERT will first DELETE the selected segment before inserting a blank line.

Deleting Segments

To delete a segment, return to the Sequence Edit screen and select a segment number. The next dialog box asks if you want to insert or delete the segment. Select DELETE. The Model 295 erases the selected segment. A blank line replaces the deleted segment.

Saving the Sequence

To save the Sequence after you have finished creating it, select END EDIT via the Sequence Edit's Menu button. See END EDIT under the Menu button for more information.

Sequence Menu Button

Selecting the MENU button while in the Sequence Edit screen displays the Sequence Menu screen. From the Sequence Edit screen select either End Edit, or Advance Trigger; see figure 4-55. The following paragraphs describes each of the items.

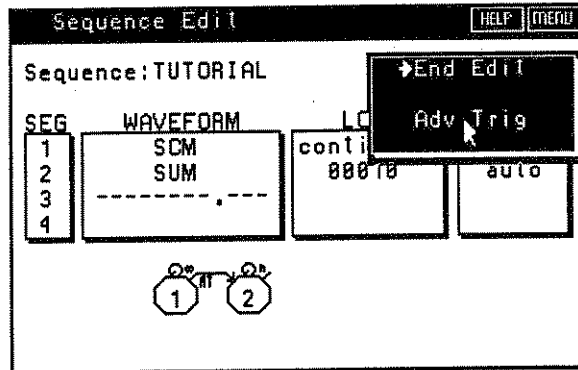

Figure 4-55. Sequence Menu Screen

End Edit

Select End Edit when finished creating or editing a Sequence. Selecting End Edit displays the Sequence Storage screen. Figure 4-56 illustrates the Sequence Storage screen and the following paragraphs describes the items on this screen. When the Model 295 stores the Sequence it copies Waveforms from their existing source location (see Waveform Window) to the same place as the stored Sequence (Disk or RAM). Waveforms chosen from the Arb Channel board (volatile memory) are in binary format. When stored, these take much more memory than the compressed format created by waveform editing. Thus copying a binary Waveform could exceed the capacity of the selected storage device.

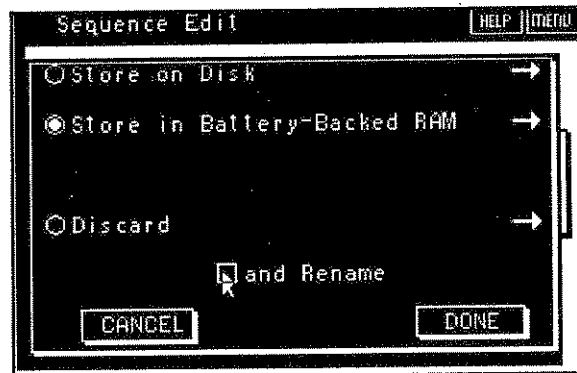

Figure 4-56. Sequence Storage Screen

Store on Disk

Selecting "Store on Disk" stores the Sequence to a disk. The disk in the drive must be formatted; see Utilities, Menu, Files: Format.

Store in Battery-Backed RAM

Select "Store in Battery-Backed RAM" to store the selected Sequence to the Model 295 battery-backed 256K RAM. To read the amount of RAM used and available, see Utilities, Menu "button", Files: Format.

Discard

Select "Discard" to end the Sequence Edit without saving the Sequence.

And Rename

Select "And Rename" along with the storage location to change the name of the Sequence before storing it. When Rename is selected, the Sequence Name screen appears; figure 4-57.

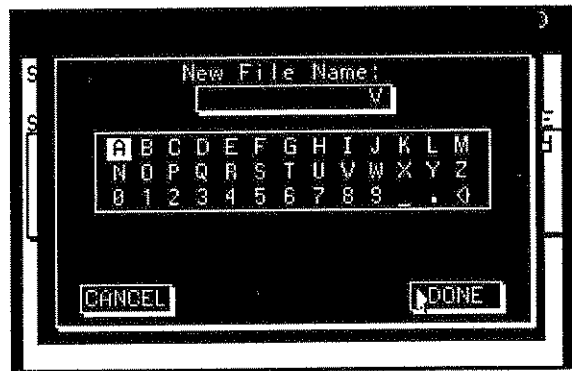

Figure 4-57. Sequence Name Screen

Sequence names can contain from one to eight characters. Use the mouse to select characters from the Character Set. As different characters are selected with the mouse, the name in the Name Box advances from right to left. Or use the up and down arrow keys to scroll through a character set (displayed in the Name Box). Use the left arrow key to accept the character and move to the next entry. Use the CLEAR key to erase the entire name. To erase individual characters, use the BSP (backspace) key. Initially the screen displays the old name. When finished select DONE to save the new name. If the new name exists, a warning is displayed. Selecting CANCEL returns to the End Edit screen.

Done

Select DONE to store the Sequence.

Cancel

Select CANCEL to stop Sequence storage.

Adv Trig

Adv Trig selects the advance trigger condition and timing for the entire Sequence. Selecting Adv Trig displays the Advance Trigger Setup screen. Figure 4-58 illustrates the Advance Trigger Setup screen and the following text describes items on that screen.

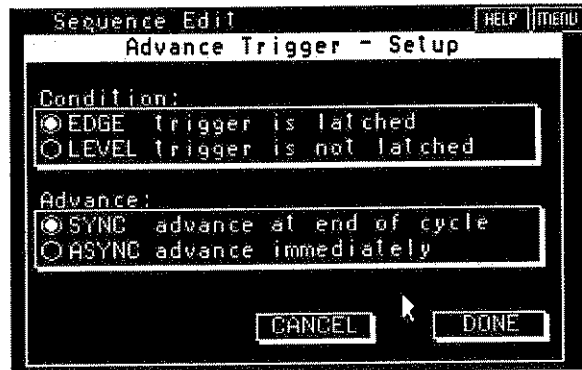

Figure 4-58. Advance Trigger Setup Screen

Trigger Conditions

Selecting one of the two Conditions designates which conditions advances to the next Waveform.

EDGE

Selecting EDGE advances to the next Waveform in the Sequence on the edge of trigger source. The edge trigger can occur before the end of the Waveform cycle because the Model 295 remembers the trigger was true. Select the trigger source, level, and edge via the Trigger Setup screen.

LEVEL

Selecting LEVEL advances to the next Waveform in the Sequence when the level of the trigger source is true. The trigger source must be true and remain true at the end of the segment. If the trigger was true and returned false before the end of the segment, the Sequence does not advance to the next Waveform.

Advance Timing

Selecting one of the two advance timing items designates when in the Waveform cycle the advance occurs.

SYNC

Selecting SYNC allows the Waveform to complete its cycle before advancing to the next Waveform in the Sequence.

ASYNC

Selecting ASYNC immediately advances to the next Waveform in the Sequence without waiting for the Waveform cycle completion.

Caution

If a segment uses Asynchronous Advance Triggering to advance to the next segment, the first two points of the next segment may be repeated twice for the first cycle only.

DONE Button

Selecting DONE accepts the new Advance Trigger Setup and returns to the Sequence screen.

Cancel Button

Selecting CANCEL rejects the new Advance Trigger Setup and returns to the initial Sequence screen.

Copy Sequence

Selecting Copy from the Sequences Management menu allows you to duplicate an existing Sequence. You must give the copy a new name, a new destination, or both. Copying Sequence provides a simple method of altering existing Sequences without destroying them. Copying a Sequence does not automatically copy the waveforms referenced in the Sequence, unless you select the "also copy waveforms" check box in the "Copy-To Name" screen following on the next page.

When a Sequence is loaded, the waveforms referenced in the Sequence must exist at the same location as the Sequence itself (Disk or RAM).

Selecting Copy first displays the Sequence Catalog ; see figure 4-59 and its following text. Select the Sequence to be copied.

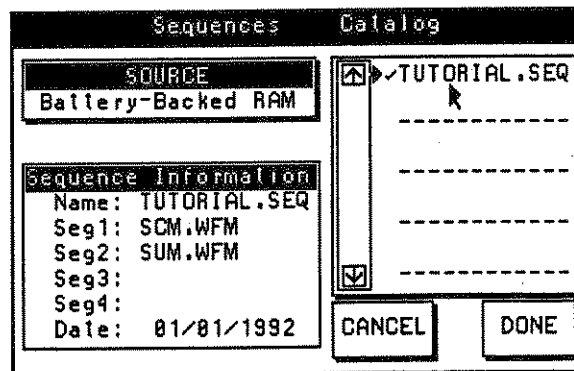

Figure 4-59. Sequence Catalog

From the Sequence Catalog select SOURCE which pops up the source list:

Disk Drive (if installed),
Battery-Backed RAM.

After selecting a source, the LISTING displays the Sequences stored in that source. Select a Sequence from the listing. A check (✓) identifies the selected Sequence. This screen also displays the Sequence's name and segments.

Select DONE to accept the Sequence. Select CANCEL to return to the original Sequence.

Next select DONE to advance to the Sequence Name screen; see figure 4-60.

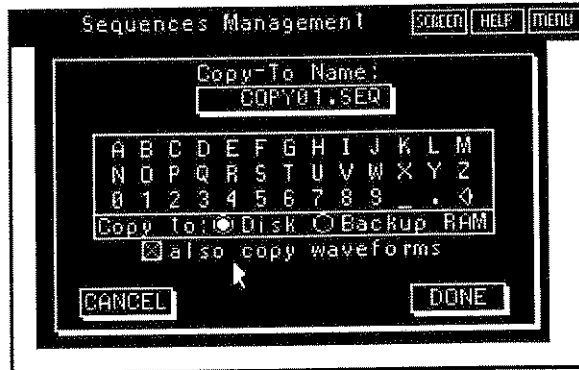

Figure 4-60. Sequence Name Screen

Use the mouse, arrow keys, or keypad to enter the new name. This screen also asks you to select the destination (storage location) for the copied Sequence:

- Disk Drive (if installed),
- Battery-Backed RAM.

If the Waveforms (segments) in the Sequence are already independently stored at the destination, there is no need to select the "also copy waveforms" check box. If you do check this box, any waveforms not already stored at the destination will be copied from the Source location along with the Sequence file.

When finished select DONE. Selecting CANCEL returns to the Sequence Menu screen.

Also you can copy Sequences via the Utilities, Files menus.

Delete Sequence

Delete allows you to eliminate an existing Sequence. Selecting Delete displays the Sequence Catalog; see figure 4-61 and its following text. Next, select the Sequence from the catalog.

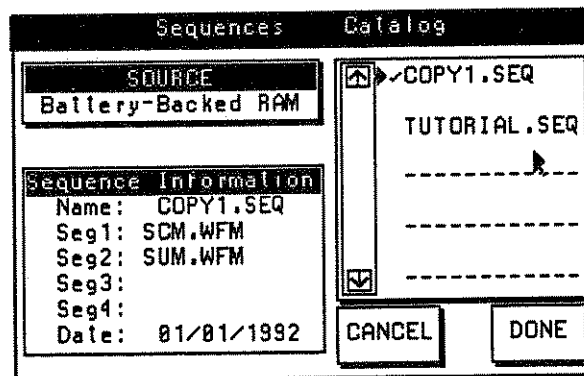

Figure 4-61. Sequence Catalog

Selecting DONE advances to the Warning screen; see figure 4-62. Selecting CANCEL from the Waveform Catalog returns to the Sequence Menu screen without removing the Sequence.

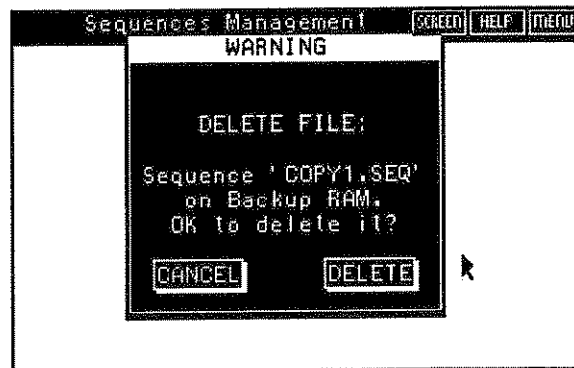

Figure 4-62. Warning Screen

Select DONE to delete the selected Sequence. Select CANCEL to return to the Sequence Menu screen without deleting the selected Sequence.

You can delete Sequences via the Utilities, Files menus.

NOTE: Deleting a Sequence will not delete the waveforms referenced in the Sequence.

New (Create) Sequence

Sequence lets you link together up to four (Arbitrary) Waveforms. In addition to creating a new Sequence, you can alter a Sequence using Edit Sequence. Editing Sequences uses many of the same menus.

Note

All Waveforms used in a Sequence must exist (New Waveforms) before using them in a Sequence.

To create a new Sequence, select Sequence via the MENU "button" or press the SEQUENCE key on the front panel. Selecting Sequence displays the Sequence Name screen. See figure 4-63.

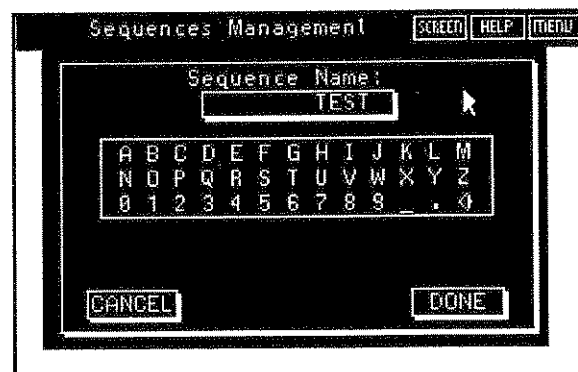

Figure 4-63. Sequence Name Screens

Sequence Name Screen

Use the Sequence Name screen to give the new Sequence a name that will identify it. The Model 295 automatically appends the Sequence name with ".SEQ" to identify the name as belonging to a Sequence.

Sequence names can contain from one to eight characters. Use the mouse to select characters from the Character Set. As different characters are selected with the mouse, the name in the Name Box advances from right to left. Or use the up and down arrow keys to scroll through a character set (displayed in the Name Box). Use the left arrow key to accept the character and move to the next entry. Use the CLEAR key to erase the entire name. To erase individual characters, use the BSP (backspace) key.

When finished naming the Sequence, select the DONE button advancing to the Sequence Edit Screen. Select the CANCEL button to terminate the new Sequence.

Sequence Edit and Menu Screens

The remaining screens for creating new sequences are identical to those used to edit sequences. The following list references paragraphs detailed in previous portions of this section.

Sequence Edit	Page 4-60
End Edit	Page 4-66
Adv Trig	Page 4-68

INSTRUMENT

The instrument screen allows you to program and control those parameters related to the Model 295 system. Figure 4-64 illustrates the initial Instrument Screen. Pressing the MENU "button" while in the initial screen toggles off and on the initial screen. The text following figure 4-64 describes each of the initial menu items.

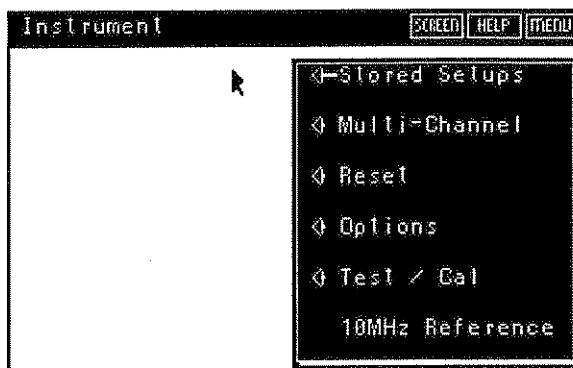

Figure 4-64. Initial Instrument Menu

Stored Setups

Setup permits you to store and recall complete instrument setups. You must name the configuration which identifies the setup when recalled. Selecting Stored Setups displays a four item list: store, recall, copy and delete; see figure 4-65.

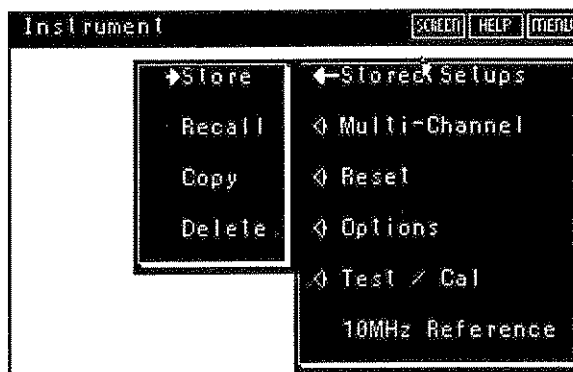

Figure 4-65. Stored Setups Menu

Store

Selecting Store from the list saves the current complete instrument setup including system settings and all Arb Channel settings. If any of the Arb Channels use the Functions: Waveform or Sequence, the Stored Setup does not automatically store the Waveform or Sequence on the Arb Channel. However, selecting "also copy waveforms" in Figure 4-66 will ensure that stored waveforms are located at the same destination as the stored setup so that they can be found. For example, if a Waveform is stored on a disk, the

Model 295 loads the waveform from disk when the Stored Setup is recalled. When you select "Store" from the Stored Setup menu, the Model 295 asks you to enter a name. Figure 4-66 illustrates the Setup Name screen and the following text describes its items. The Model 295 automatically appends the Setup file with the extension .SCF.

NOTE

If you name a Setup file STARTUP in Battery-Backed RAM, the Model 295 automatically recalls that file at power on.



Figure 4-66. Setup Name

Use the mouse, arrow keys, or keypad to enter the new name. This screen also asks you to select the destination of the Stored Setup:

- Disk Drive (if installed)
- Battery-Backed RAM

When you select the "also copy waveforms" check box, and the selected Function is a Waveform or Sequence, the waveforms used in the Stored Setting are also copied to the destination (if not already there).

When finished select DONE. Selecting CANCEL returns to the Instrument screen.

If a channel is running a User Defined Waveform or a Sequence, then there are several items to consider:

1. The Stored Setup will contain the name of the Waveform or Sequence, not the actual data itself. The location of the actual Waveform or Sequence file must be the same as where the Stored Setup is being saved (Battery Backed RAM or Disk.) If it is not, and "also copy waveforms" is not checked, a warning message will be displayed. For example:

If a waveform is loaded from the Battery Backed RAM, followed by saving a Stored Setup to Disk, a warning message will indicate the problem. You may continue with the Setup Save, and then later copy

the waveform from RAM to disk by using the Utilities-Files-Copy command.

2. If a waveform was loaded from over the GPIB, or it was loaded from disk as a '.wfm' (waveform DSP file format) or '.wft' (ASCII file format), then a warning message will indicate that the waveform exists only in channel memory. You may continue with the Setup Save, and then later copy the waveform from the current channel to the same storage location (Battery Backed RAM or Disk) by using the Waveforms-Copy command.
3. If a waveform contains more than 15 position markers, a message will appear indicating that not all of the position markers have been saved. If this is a problem, then there is a way to go about storing as many position markers as required:

When a waveform is created using the waveform new/edit commands, it is kept in a compressed equation format which conserves storage space, but does not allow the saving of position markers as part of the waveform data. But when a waveform is copied from the current channel (the channel's trace RAM) to Battery-Backed RAM or a disk, then it is kept in a binary data format which requires more storage space, but allows the position markers to be stored along with the waveform data. Therefore, to include position markers, copy the waveform from the current channel to the desired storage location (Waveforms-Copy), then reload the waveform from that storage location (Waveforms-Load) then perform the Stored Setup save to the same storage location. The message will still appear, but the markers will be stored as part of the waveform.

Recall

Selecting Recall from the Stored Setups menu allows you to do a complete instrument setup or configuration. A complete instrument setup includes system settings and Arb Channel settings. If any of the Arb Channels use the Functions: Waveform or Sequence, the Stored Setup may not include the Waveform or Sequence, but it does remember the storage location of the Waveform. For example, if a Waveform is stored on a disk, the Model 295 expects to find the waveform on the disk. If the waveform is not on the disk, an error message is displayed and recall aborted. This can generally be avoided by checking "also copy waveforms" when creating the Stored Setup (see Figure 4-66).

Note: When a RECALL is aborted portions of the setup could be transferred into memory. To set the channels to a known state after this occurs, use Reset via the Instrument key.

Note: If the Stored Setup contains information on more channels than are currently installed in the instrument, this extra setup information is ignored. If more channels are installed than the Stored Setup has setup data for, the configuration of the extra channels is not changed in any way.

When Recall is selected, the Model 295 displays the Setups Catalog; see figure 4-67. The Model 295 appends Setup files with the file extension .SCF.

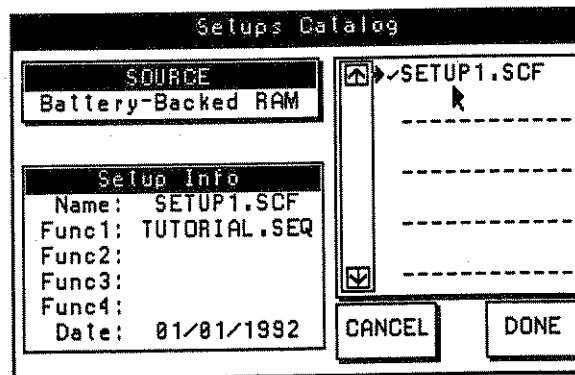

Figure 4-67. Setups Catalog

From the Setups Catalog select SOURCE which displays the source list:

Disk Drive (if installed)
Battery-Backed RAM

After selecting a source, the list displays the Setups stored in that source. Select a Setup from the listing. The Information screen shows the Setup's name as well as each Arb Channel's function.

Select DONE to accept the Setup and return to the Instrument screen. Select CANCEL to return to the Instrument screen without recalling the Setup.

When recalling a Stored Setup which references Waveforms or Sequences, there are two items to consider:

1. The Stored Setup will contain the name of the Waveform or Sequence, not the actual data itself. The location of the actual Waveform or Sequence file is assumed to be the same as from where the Stored Setup is being recalled (Battery Backed RAM or Disk). This is generally assured by using the "also copy waveforms" check box in Figure 4-66. If it is not, an error message will be displayed, and the recall setup will be incomplete. The setup state of the channel which was to load the Waveform or Sequence will be in an unknown state. It is best to perform a reset on the channel to set it to a known state (see Instrument-Reset).
2. If there is not enough available channel memory to perform a Waveform or Sequence load, then an error message will appear indicating 'Insufficient Memory'. In order to successfully perform the recall of the Stored Setup, waveforms in the channel memory will have to be deleted. Resetting the channel will not delete waveforms from the channel memory. Use "Waveforms-Delete" with the source set to the current channel to delete waveforms from the channel memory.

Copy

Copy allows you to duplicate an existing Stored Setup. You must give the copy a new name. Copying Setups provides a simple method of altering existing Setups without destroying them.

When Copy is selected the Setups Catalog (Figure 4-67) appears. From the Setups Catalog, select the Setup you want to copy. Next, select OK to advance to the Setup Name screen; see figure 4-66.

Use the mouse, arrow keys, or keypad to enter the new name. This screen also asks you to select the destination (storage location) for the copied Setup:

- Disk Drive (if installed),
- Battery-Backed RAM.

After entering the name and selecting the destination, select DONE to copy and name the Setup. Selecting CANCEL returns to the Instrument Menu screen without copying the Setup.

Setups also can be copied via the Utilities, Files menus.

Delete

Delete allows you to remove Stored Setups stored on disk, and battery backed RAM. Setups can also be deleted via Utilities: Files.

Selecting Delete displays the Setups Catalog; see figure 4-67. Select the Setup you want to delete.

From the Setups Catalog select SOURCE which displays the source list:

- Disk Drive (if installed),
- Battery-Backed RAM.

After selecting a source, the LISTING displays the Setups stored in that source. Select a Setup from the listing. A check (✓) identifies the selected Setup.

Selecting DONE advances to the Warning screen; see figure 4-68. Selecting CANCEL from the Waveform Catalog returns to the Waveform Menu screen without deleting the selected Waveform.



Figure 4-68. Warning Screen

Select OK to delete the Setup. Select CANCEL to return to the Instrument Menu screen without deleting the selected Setup.

When a Setup is DELETED, Sequences or Waveforms that it uses are not deleted.

Multi-Channel

Multi-Channel consists of two items related to operations involving two or more Arb Channels: Channel Grouping (Clock) and Analog Summing; see figure 4-69.

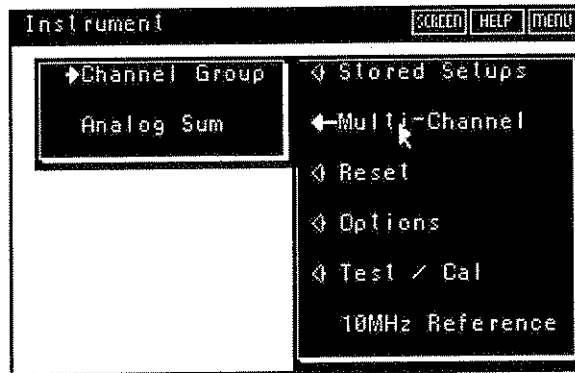

Figure 4-69. Multi-Channel Screen

Channel Group - Clocks

The Model 295 permits selection of the Arb Channel's clock sources. In the Model 295, the clock drives the address generator whose addresses in turn drive the Arb's DAC.

Arb Channels can be configured in master / slave relationships. With only one channel being the master. Individual Arb Channels can be configured as independent Arb Channels which supply their own clocks. Clock sources can be either internal or external. Figure 4-70 illustrates the clock combinations.

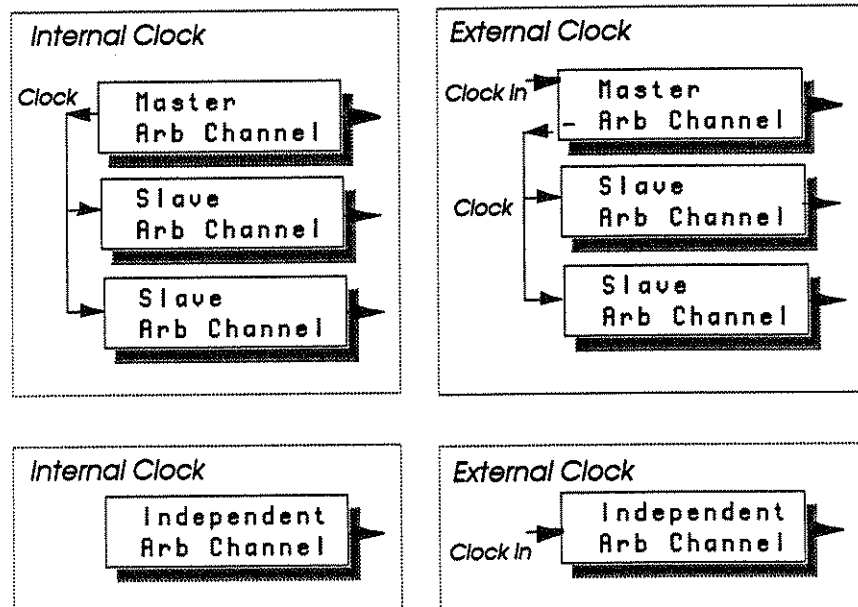

Figure 4-70. Model 295 Clock Configurations

Channel Group Screen

From the Channel Group Screen set up the clock source and clock relationship, as well as, enable phase lock.

To setup Master / Slave, all related channels must be running the same type of function, either standard or arbitrary (sequence, or waveform). Also, the related channels can not be running in any of the sweep modes if Phase Locking is desired.

On the Channel Grouping menu (figure 4-71), select the clock source (internal or external master clock). External master clock input is accessible via Arb Channel Clock In/Out.

The next portion of the screen selects channel clocks. Only those channels installed in the unit will be listed. Each channel has three choices: Master, Slave, and Indep (independent). Select the clock using the radio buttons. In addition, any or all channels can be designated as independent channels which permits them to use their own internal clock source or external clock source. Remember only one channel can be designated a Master clock.

Unless all channels are set to "Independent", Channel 1 must be part of the Group (either as "Master" or "Slave").

Phase Lock

To setup Phase Lock, the master / slave criteria must first be met. Channels running arbitrary waveforms must all have the same size waveforms. Sequences can not be phase locked.

Select phase lock by selecting the radio button. When finished, select the "Done" button which accepts the changes and returns to the Instrument screen. If you give up, select the "Cancel" button which returns to the Instrument screen returning to the previous clock settings. Select "Restore" to return to the previous clock settings without leaving the Channel Grouping screen. The Model 295 will tell you when you exit the Channel Group screen if any of your settings are wrong.

Channel Grouping				
Master Clock Source: INTERNAL				
Chan	Master	Slave	Indep	Phase Lock
1	<input type="radio"/>	<input checked="" type="radio"/>	<input type="radio"/>	<input type="checkbox"/>
2	<input checked="" type="radio"/>	<input type="radio"/>	<input type="radio"/>	<input type="checkbox"/>

k

CANCEL **DONE**

Figure 4-71. Channel Group

Analog Sum

Analog Sum provides internal analog signal summing bus between Arb Channels. To use Analog Sum the Model 295 must contain at least two Arb Channels. Figure 4-72 illustrates the Analog Sum screen. This screen displays only the Arb Channels installed. Also, the screen provides a schematic of channel interconnections. In figure 4-72 Arb Channel 1 output sums to Arb Channel 2.

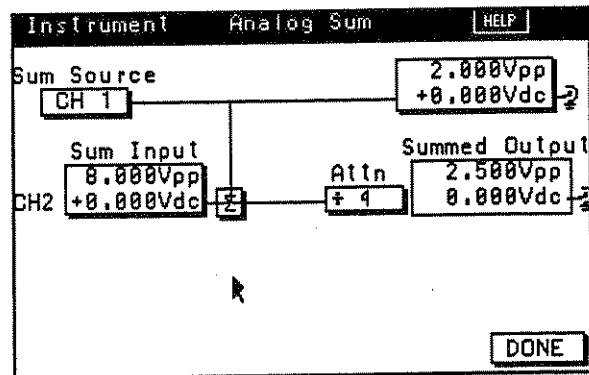

Figure 4-72. Analog Sum

For analog summing you must select one Arb Channel as the signal source. You can select any of the remaining Arb Channels as summing channels. Until you select a source channel, all the fields are dashed out (disabled).

To connect Arb Channels to the summing bus, select the "Summing Box" on the screen. The Analog Sum screen displays the initial values set via the Channel Setup screen. Any value on the Analog Sum screen except the "Summed Output" can be selected and changed; the Model 295 automatically updates the Channel Setup. The channel summing voltage, "Sum Input", and "Attenuator" for each Arb Channel are interrelated, thus changing one could change one or both of the others.

Summed Output

Each of the Summing Channels displays its programmed (post attenuator) levels. This screen displays the levels in volts peak to peak (Vp-p) and volts dc (Vdc). This value includes any contribution from the "Sum Source" channel (if enabled), assuming that the source has identical Function and Phase characteristics. This value cannot be edited.

Attenuator

Select Atten to select one of the Arb Channel's binary output attenuators: 0dB (+1), 6dB (+2), 12dB (+4), 18dB (+8), 24dB (+16), 30dB (+32), 36dB (+64), and 42dB (+128). Remember, the summing input is ahead of the attenuator. Thus, the attenuator divides both the Summing Channel level and the Source Channel's level.

Channel Sum Input

This value is the Arb Channels internal amplitude and offset (pre-attenuator) voltages.

Reset

Reset allows you to set the Model 295 to its default conditions. Reset allows you to set selected parts of the Model 295 to default configuration. Choices available for Reset are Full Instrument, Current Channel, and Backup RAM. Before the chosen Reset is performed you are given a warning and an opportunity to cancel the operation.

Following is a list of Model 295 defaults for each Reset type:

Current Channel:

Function	Sine
Frequency	1kHz
Amplitude	1.0Vp
Offset	0.0Vdc
Mode	Continuous
Output	Off
Modulation	AM, off (None)
Filter	Elliptic
Phase	0.0 degrees
Sweep -	Up, - Sweep & Reset, - Linear, - Time 1.000 Sec, - Start Frequency 1kHz, - Stop Frequency 10kHz
Sync Output	Off
Channel Clock	- Independent, - Internal Source, - Output Off - Clock Mode frequency 1kHz
Trigger- Channel Internal Source,	- Trigger Count 1, - Trigger rate 1kHz, - Synchronous, Positive Polarity.

Full Instrument:

All items under "Current Channel" above for all channels. Also:

System Ref. Clock	External Input, Internal if no input
System Trigger	TTL Positive
Z-Axis	0V, Positive
<i>High Voltage Option</i>	
High Voltage Output	Off
High Voltage Input	Off
High Voltage Summing	Off
H V Output Level	10 Vp-p

Backup RAM:

All files present in Backup RAM are deleted. These include Waveforms, Sequences, Stored Setups, and all "Other". Reset parameters are:

- LCD - Blink Rate,
- Viewing Angle,
- Display Mode (Black on White),
- IEEE488 Address (9)
- Beeper Enabled
- Mouse - Enabled,
- Double-click (Medium),
- Sensitivity (Fast)

Options

Selecting "Options" from the Instrument Menu brings up a sub-menu (see Figure 4-73) from which you can select screens to control any installed Options. The High Voltage Option 007 is a complete Channel card used to sum in the outputs from the ARB Channels or an external input, and output a high voltage signal. If all installed channels are ARB channels and no 007 Option is installed, selecting "High Voltage" will bring up an Information Screen stating the "High Voltage Option not installed". If installed, this will bring up the "High Voltage Option" screen. Refer to Appendix G of this manual for installation, operation and programming of the High Voltage Option card.

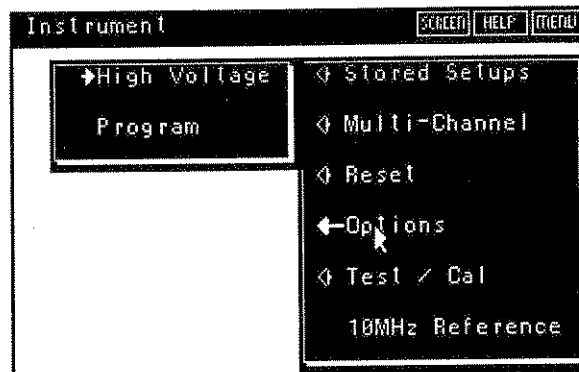

Figure 4-73. Instrument Options Menu

Selecting "Program" will cause the model 295 to check for the presence of a floppy diskette in the Option 002 Disk Drive. If there is no Disk Drive, or no diskette in the drive, an Information screen will advise you of this condition. If there is a diskette present, the model 295 will display the "User Programs Catalog". If there are any DSO files on the diskette they will be catalogued by name and selectable. See Appendix F of this manual for operating instructions for Option 005 - Direct DSO Download. Once a user Program has been loaded, selecting the Program menu option invokes the loaded program's main screen instead of the "User Programs Catalog."

Test/Cal

Test/Cal performs self-tests and calibration on selected Arb Channels. Figure 4-74 illustrates the Test/Cal sub-menu and the following text describes items selected on that screen.

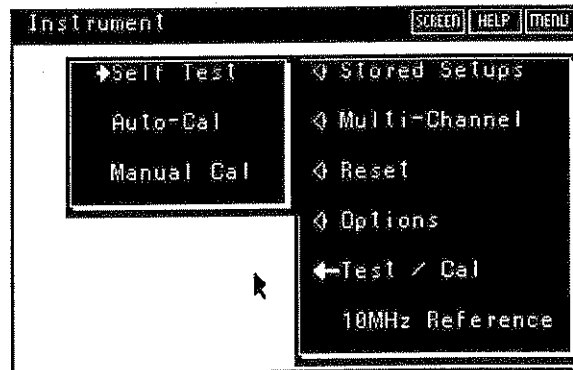

Figure 4-74. Test/Cal Sub-menu

Perform Self-Test

Selecting this item performs a self-test on any or all installed channels. A dialog box pops up which lets you select the channel or channels to test. After each channel is completed, an information box shows the result of the test. A value of 0 is normal. Select DONE to remove the box.

Perform AutoCal

Selecting this item performs an AutoCal on any or all installed channels. A dialog box pops up which lets you select the channel or channels to AutoCal. After the calibration is completed on each channel, an information box displays the results of the calibration. A value of 0 is normal. Select DONE to remove the box.

Manual Calibration

Selecting this item allows you to make several adjustments to the Model 295 that require external test equipment and data entry. For more information on manual calibration, refer to the Maintenance manual.

If Autocal has not successfully completed on the chosen channel, Manual calibration cannot be performed and will not be allowed.

Done

After the last Channel, selecting Done ends Test and Calibration and returns the display to the main Instrument screen.

10 MHz Ref

The Model 295 10 MHz reference provides the time base for the frequency synthesizer in each Arb Channel. You can select either the internal reference, or provide an external source. Either choice affects the REF IN/OUT connector on the Model 295 rear panel.

With Output chosen (see Figure 4-75), the internal 10 MHz reference is used, and routed to appear on the REF IN/OUT connector.

The Input selection makes the REF IN/OUT connector an input, to which you can apply a 10 MHz TTL signal ($\pm 1\%$). Whenever the signal is either out of specification or missing entirely, the Model 295 automatically switches to the internal reference until a valid external signal is again available. When the switch from external to internal reference occurs, the instrument displays a message box telling you that it has completed this switch. Select DONE to remove the message. This message will NOT appear while a menu list is being displayed, but will show up as soon as the menu is removed.

Select DONE to remove the 10 MHz REFERENCE dialog and return to the Instrument Screen menu.

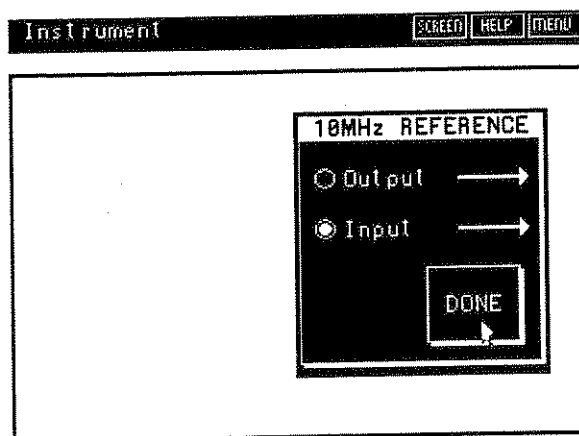

Figure 4-75. Reference In/Out

UTILITIES SCREENS

The Utilities screen allows you to perform several useful functions. This screen lets you manage files (both RAM and disk), set up the screen and mouse, configure the remote interface, and set the date and time. Select Utilities using either the UTILITIES key or Utilities via the SCREEN "Button". Then the Model 295 displays the initial Utilities menu; see Figure 4-76. The following text describes each menu and its use.



Figure 4-76. Initial Utilities Screen

Files

Selecting Files permits the reading of a source directory (figure 4-77). From the listing select a file and copy, rename, or delete that file. The Files section of Utilities is a central place for all types of file operations. From this screen you manage files on disk or in Battery-Backed RAM. Although most of what you can do is directly on the files screen (see figure 4-77), a few lesser-used options are found on the Files menu.

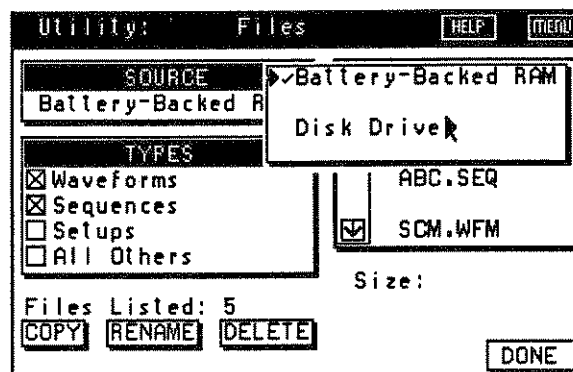

Figure 4-77. Utilities File Screen

Source

Use "Source" to select either storage medium: the battery-backed RAM or optional disk drive. "Listing" displays those files selected from "Types".

Types

Use "Types" to control which type(s) of files from the chosen Source are to be included in the listing. Selecting "Waveforms" lists all *.wfm* Model 295 generated waveform files, *.wfm* WaveForm DSP™ generated waveform files, and *.wft* ASCII delimited waveform files. Selecting "Sequences" lists all *.seq* files. Use "Setups" to lists all *.scf* files. Using "All Others" allows you to list all non-Model 295 files (*.pcx*, *.txt*, etc.). You can select as many of the file types as you wish to list. The *.wft* files will only be found on the Disk Drive source.

NOTE

At power on, the Model 295 will read a file from Battery-Backed RAM named "STARTUP.SCF". The Model 295 does not automatically create this file, but you can by creating a Stored Settings file and naming it "STARTUP."

Listing

The "Listing" is a directory of files from the selected source of the selected type(s). Select a file by clicking the mouse on the file name. Once selected you can copy, rename, or delete the file. The "Files Listed" section lists the quantity of files of the selected types in the source. Under the listing appears the size in bytes of the selected file, as well as the date and time the file was stored.

Copy and Rename

The two buttons allow you to copy or rename a selected file.

To copy a file, select the file from the listing. Select the COPY button. Use the Copy-To Name screen to name the file. Then select the storage location: Disk or Backup RAM. Select DONE to copy the file or CANCEL stop the copy and return to the File screen. If you leave the name the same as one already at the destination, the 295 will prompt you if you wish to over-write the old file. Copying files other than Waveform, Sequence, or Setups files to RAM will change the copied files to the "All Others" type.

Rename a file by selecting the file from the listing and selecting the RENAME button. Then use the New File Name screen to give the file a new name. Selecting DONE renames the file. Selecting CANCEL to maintain the old name and return to the File screen.

Delete

Delete allows you to delete a selected file. A warning message gives you a second chance.

Done

Select Done when finished with the file screen.

Files Menu Button

Selecting the Menu button allows you to work with the disk or RAM.

Disk

The Disk menu item has four operations associated with it. First, "Get Info" displays a message box with information about the currently inserted floppy disk (figure 4-78 illustrates a disk "Get Info" box).

"Format" puts a standard MS-DOS format onto a 1.44 MB or 720 KB diskette. A warning message gives you a chance to cancel the formatting before you lose any data you want to keep. Formatting a disk takes around 3 minutes. During that time a "Standby" message appears. The Model 295 cannot be used for other operations while formatting is in progress.

"Run Program" is a mechanism through which you can run programs created for the Model 295 and provided to you by Wavetek on diskette.

"View PCX Image" takes a monochrome PCX format image of 320 horizontal by 200 vertical pixels or less and displays it on the LCD. If you have selected a file before choosing this menu item, the instrument automatically displays that file. Otherwise you are prompted to enter the name of the disk file to display. Pressing any key removes the image and restores the Files screen.

One use of "View PCX Image" option is to view screen captures you may have made. At any time, if you press the ",", "4" and "(" keys simultaneously, a copy of the currently displayed screen is stored on floppy disk. The file created is named "M295xxxx.PCX", where "xxxx" is the first number the Model 295 can use that generates a file name not already existing on the floppy (for example "M2950002.PCX").



Figure 4-78. Disk Get Info Screen

RAM

Selecting RAM allows you to read information (via Get Info) about the Model 295 internal RAM. The Information screen (Figure 4-79) lists the total number of bytes in the memory, the number of free bytes, and the number and types of files. Select DONE when finished with the information screen.

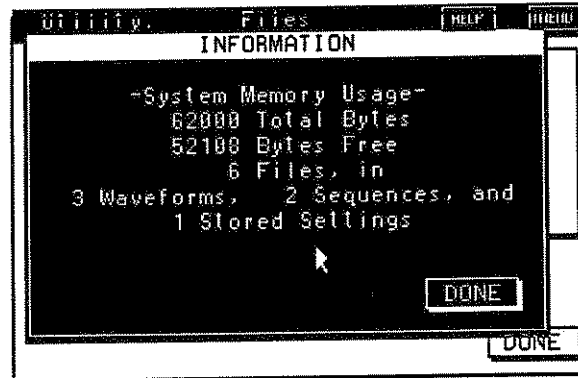

Figure 4-79. RAM Get Info Screen

LCD/Mouse/Beeper

Selecting LCD/Mouse/Beeper allows you to customize the Model 295 screen and mouse. Figure 4-80 illustrates the Preferences screen and the following text describes items from that screen. Select DONE when you have finished setting your preferences.

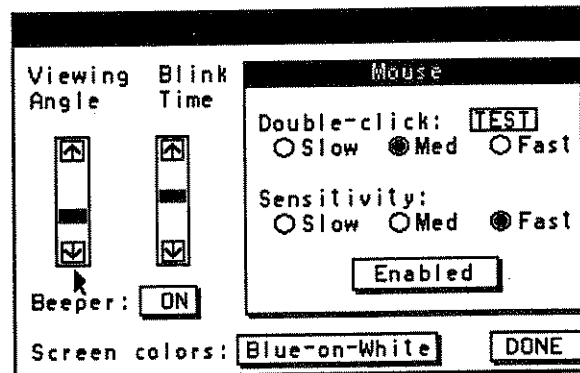

Figure 4-80. LCD/Mouse/Beeper Screen.

Viewing Angle

Use Viewing Angle to adjust the contrast of the Model 295 display. Change the viewing angle by selecting the Viewing Angle's slider box and moving the box up or down. "Up" darkens the display, and "down" lightens the display.

Blink Time

Use Blink Time to vary the display's blinking or flashing time. Adjust the blink time by selecting the Blink Time slider box and moving the box up or down. Moving the box up increases the blink time, and moving the box down decreases the blink time.

Mouse

Double-Click Rate

Use Double-Click Rate to set how fast (slow, medium, or fast) the mouse buttons selects an item. Point the mouse at the TEST box and double-click the mouse's left button. If you click at the right rate, the TEST box changes.

Sensitivity

Use Sensitivity to set the speed (slow, medium, or fast) the mouse cursor moves across the display.

Enabling or Disabling the Mouse

Use this box to enable or disable the mouse. To disable the mouse, select the ENABLED box. Remember, if you disable the mouse, you must use the front panel keys to operate the unit. If you enable the mouse, you can use both the mouse and front panel keys to operate the unit. To enable the mouse you must select DISABLED using the front panel keys.

Beeper

The Model 295 "Beeper" provides aural feedback for front panel key presses. For your convenience, the Model 295 permits you to turn off the beeper. To turn the beeper off, select the Beeper ON box which toggles to OFF.

Screen Colors

Use Screen Colors to toggle between normal (blue-on-White) and reverse (White-on-blue) image displays. To change the colors, select the Screen Colors box. Figure 4-81 illustrates the two screen colors.



Figure 4-81. Screen Color Samples

Remote

Use Remote to set up the Model 295 RS-232 or IEEE 488 port communication ports. Figure 4-82 illustrates the Remote screen and the following text describes the items on the screen. For more information on remote operation, refer to section 5 of this manual. Select DONE when finished with this screen.

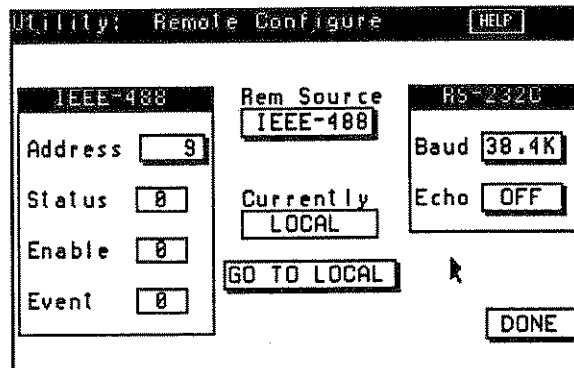

Figure 4-82. Remote Screen

1
2
3
4
5
6
7
8
9
10
11
12
13
14
15
16
17
18
19
20
21
22
23
24
25
26
27
28
29
30
31
32
33
34
35
36
37
38
39
40
41
42
43
44
45
46
47
48
49
50
51
52
53
54
55
56
57
58
59
60
61
62
63
64
65
66
67
68
69
70
71
72
73
74
75
76
77
78
79
80
81
82
83
84
85
86
87
88
89
90
91
92
93
94
95
96
97
98
99
100

INTRODUCTION

Model 295 firmware supports several industry standards and specifications (SCPI, IEEE 488.2, IEEE 488.1, and RS-232) in remote operation.

Standard Commands for Programmable Instruments (SCPI)

The SCPI Standard, first published in 1990, is layered on top of the IEEE 488.2 Standard. SCPI defines program messages, response messages, and data formats that are consistent across all instruments, regardless of manufacturer. The goal of these definitions is to reduce ATE program development time. SCPI is designed to be layered on top of the interface independent portion of IEEE 488.2. It is independent of the controller to instrument interface.

In the simplest sense, the IEEE 488.2 standard defines the syntax of a command language while the SCPI standard defines the vocabulary.

IEEE Standard Codes, Formats, Protocols, and Common Commands (IEEE 488.2)

This standard defines communication protocols necessary to effect application independent device-dependent message exchanges and defines common commands and characteristics useful in instrument system applications.

Among the items this standard defines are standard message handling protocols including error handling, unambiguous program message and response message syntactic structures and standard status reporting structures.

IEEE Standard Digital Interface for Programmable Instrumentation (IEEE 488.1)

This standard deals with the interface characteristics of programmable instrumentation. It specifies device-independent mechanical, electrical and functional interface requirements which enable independently manufactured apparatus to be interconnected in a single system.

IEEE-488.1. (GPIB) Setup

Operating the Model 295 via IEEE-488 consists of three steps: hardware setup, instrument setup, and commands.

Hardware Setup

Connect the Model 295 to an IEEE-488 device (figure 5-1) using a bus cable with Amphenol 57-10240 or equivalent connectors. Cable sets are available from Wavetek in 1 and 2 meter lengths.

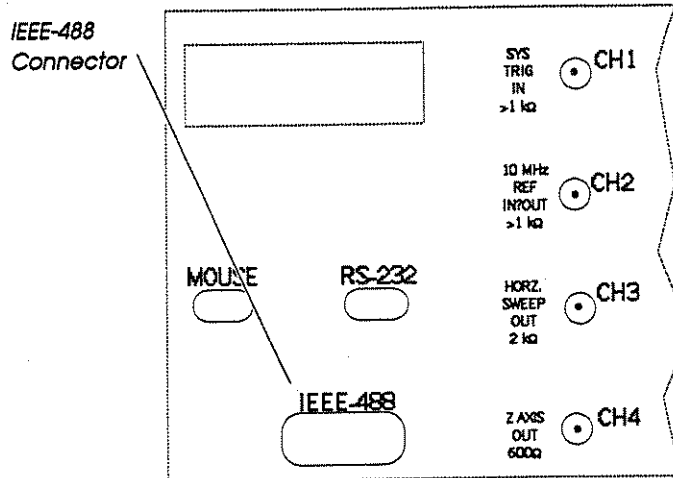

Figure 5-1. IEEE-488 Connector

Instrument Setup

To set up the IEEE-488 port, select Remote by way of the UTILITIES key. Figure 5-2 points out the IEEE-488 items on the Remote screen. The Remote screen also sets up the RS-232 port.

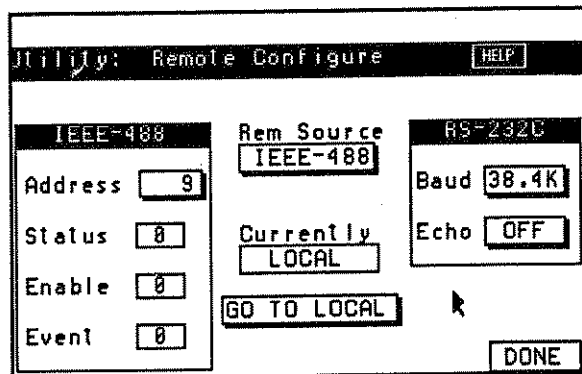

Figure 5-2. IEEE-488 Screens

RS-232 Setup

Operating the Model 295 via RS-232 consists of three steps: hardware setup, instrument setup, and commands.

Hardware Setup

To connect the Model 295 to an RS-232 device (figure 5-3), use a standard RS-232 cable (interface type E).

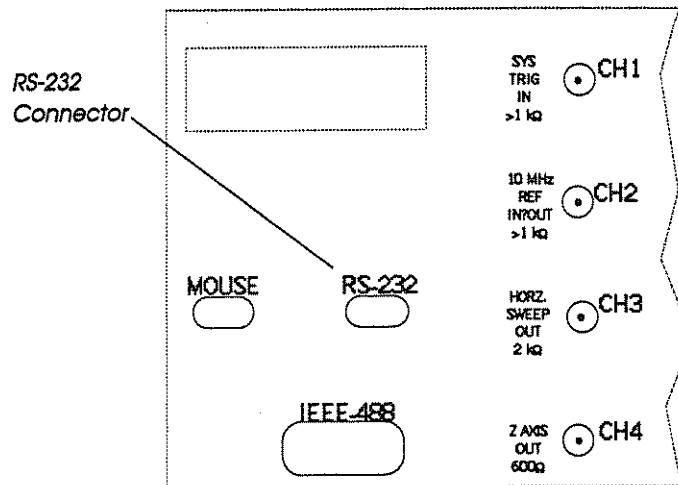

Figure 5-3. RS-232C Connector

Instrument Setup

To set up the RS-232 port, select Remote by way of the UTILITIES key. Figure 5-4 points out the RS-232 items on the Remote screen. The Remote screen also sets up the IEEE-488 port.

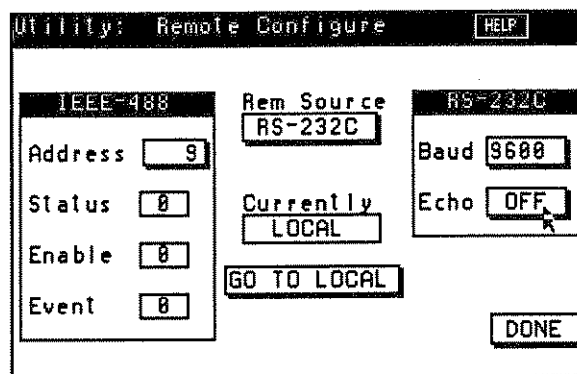

Figure 5-4. RS-232 Screen

Remote Source

Select the "Remote Source" field to toggle between the RS-232C port and the IEEE-488 port as the remote I/O ports.

Currently

This annunciator identifies the current control condition. If LOCAL is displayed, the Model 295 is programmed via its front panel keys or mouse. If the REMOTE is displayed, the RS-232C controls the Model 295. When the Model 295 receives the Local Lockout command, this annunciator displays LOCAL LOCKOUT.

RS-232C

Select the RS-232C field to display a listing of RS-232C Baud rates: 38.4K, 19.2K, 9600, 4800, 2400, 1200, 600, 300, 110, and 50. From the list select the Baud rate to match the remote device connected to the port.

Commands

For a listing and description of the Model 295 command set, see "Command Table" in this section.

REMOTE PROGRAMMING

The Model 295 communicates within the SCPI (Standard Commands for Programmable Instruments) and IEEE 488.2 standards. Therefore, the Model 295 responds to two types of commands: SCPI commands and IEEE 488.2 Common Commands. The IEEE 488.2 Common Commands support functions that are common to all instruments, such as reset, self test and status reporting. Common Commands are non-hierarchical (can be included within SCPI commands without disturbing their hierarchical relationships) and are easily identified by their leading asterisk (*). SCPI commands support functions that are specific to the instrument. For complete SCPI language specifications, contact Wavetek

The paragraphs under this heading provide the following information:

Command Message Format

Model 295 SCPI Commands

Self Test Query Response

IEEE 488.2 Common Commands

SCPI Command Summary

Table 5-1 lists the SCPI commands used in the Model 295 and indicates their hierarchical relationships. Each SCPI command is described in detail under "SCPI Commands" in this section. The IEEE 488.2 Common Commands are listed under "IEEE 488.2 Common Commands" also in this section. Table 5-1 is organized as follows:

Keyword	Parameter Form	Notes
[SOURCE<n>] :FREquency		
[:CW]	<numeric_value>	
:MODE	CW SWEep	
:RASTer	<numeric_value>	
START	<numeric_value>	
STOP	<numeric_value>	

The indentations of *keywords* indicates their hierarchical relationships according to a tree system. The left-most edge is called the *root node*. Keywords closer to the root node are higher in hierarchy; lower nodes are to the right of their parent node. The right-most keywords are located at the *leaf node*. Notice that all root level keywords (except System) accept a numeric suffix <n>. This number identifies an Arb Channel number, and it defaults to "1" if not provided. To program or query a settable parameter, the full path must be defined to reach the keyword appended with the required parameter form. A SCPI programming string typically starts at the root node and proceeds to the right through branch nodes to a leaf node. This sequence of keywords is defined as a Program Header. A Program Header can be either a "command" Program Header or a "query" Program Header. A Program Header optionally followed by Program Data is defined as a Program Message Unit.

In the previous example, the left-most keyword, [SOURce], is directly off the root node. Nodes in this position are called *Subsystems*, and all keywords indented under [SOURce] are part of the Source Subsystem. FREQuency is one of the main parameters under the Source Subsystem. The keywords under FREQuency set or query the various frequency related parameters. The brackets around the SOURce and CW keywords indicate that they are *implied keywords*, and they may be included in or omitted from the program header at the programmer's option. When included, do not use the brackets in the command. Referring to Table 5-1, [SOURce] is the only Subsystem which is in brackets. This is the default Subsystem, and is assumed unless another Subsystem is specified at the start of a command.

The root node itself is an implied node and is not directly programmed. A colon at the start of a Program Message Unit resets the SCPI parser to the root node. The leading colon at the start of a message containing one or more Program Message Units is not necessary.

Long and Short Form Keywords

The SCPI parser recognizes specific keywords that must be in the accepted long or short format. No other form of the keyword is accepted. For example, to send "frequency" as part of a message, the short form keyword, shown in the table as upper case letters "FREQ", or the long form of the same keyword containing both upper and lower case characters "FREQuency" may be sent. Equal weight is given to upper and lower case characters.

Table 5-1. SCPI Command Summary

Keyword	Parameter Form	Notes
CALibration<n> [:ALL]? :DATA :AFCorrection :AMPLitude [:GAIN] :OFFSet :AMZero OFFSet [:GAIN] :OFFSet :PAZero :SCMZero :STORE :SQRSymmetry :STATE	<block> <point>,<frequency>,<gain> <numeric_value> <numeric_value> <numeric_value> <POSitive NEGative>,<numeric_value> <POSitive NEGative>,<numeric_value> <numeric_value> <numeric_value> <numeric_value> <boolean>	
INITiate<n> [:IMMediate] :CONTinuous	<Boolean>	
MMEMory :CATalog? :COPY :DELeTe :INITialize :LOAD :SEQuence :SETup :TRACe :STORE :SETup :TRACe	<RAM DISK> <source_name>,<RAM DISK>,<dest_name>,<RAM DISK> <file_name>,<RAM DISK> <RAM DISK> <n>,<sequence_name>,<RAM DISK> <setup_name>,<RAM DISK> <n>,<trace_name>,<RAM DISK> <setup_name>,<RAM DISK> <n>,<trace_name>,<dest_name>,<RAM DISK>	
OUTPut<n> :CLOCK :FREQuency :MASTer :SOURce [:STATE] :SOURce :FILTer [:LPASs] [:STATE] :SElect [:STATE] :SUMBus [:STATE] :TRIGger [:STATE] :SOURce	<numeric_value> <INTernal EXTernal> <Boolean> <RASTer SYNThesizer> <Boolean> <ELLiptic BESSel> <Boolean> <Boolean> <Boolean> <BIT BCOMplete LCOMplete>	

Table 5-1. SCPI Command Summary

Keyword	Parameter Form	Notes
RESet<n>		
[SOURce<n>]		
:AM		
[:STATe]	<Boolean>	
:MODE	<AM SCM>	
:CLOCK		
:CONFigure	<INPut OUTPut>	
:FREQuency		
[:CW FIXed]	<numeric_value>	
:MANual	<numeric_value>	
:MODE	<CW FIXed SWEEp>	
:RASTer	<numeric_value>	
:STARt	<numeric_value>	
:STOP	<numeric_value>	
:FUNCTion		
[:SHAPE]	<shape_name>	
:USER	<trace_name>	
:MODE	<FIXed SEQuence>	
:GROup	<numeric_value>	
:MARKer		
:POStion		
:AOff	<trace_name>	
:POINt	<trace_name>,<point_index>	
:ZAXis		
:AOff	<trace_name>	
:POINt	<trace_name>,<point_index>	
:SYNC		
:SOURce	<ZCRoss BBITs>	
[:STATe]	<Boolean>	
:TRIGger		
[:STATe]	<trace_name>,<Boolean>	
:PHASe		
[:ADJust]	<numeric_value>	
:MODE	<INdependent MASTer SLAVe>	
:ROSCillator		
:SOURce	<INternal EXTernal BUS>	
:SEQuence		
:ADVance	<AUTOMatic TRIGgered>,<list_index>	
:DWELL	<numeric_value>,<list_index>	
:FUNCTion	<trace_name>,<list_index>	
:LENGth	<numeric_value>	
:TRIGger		
:SENSe	<EDGE LEVel>	
:MODE	<SYNChronous ASYNchronous>	
:SUMBus		
[:STATe]	<Boolean>	
:ATTenuation	<numeric_value>	

Table 5-1. SCPI Command Summary

Keyword	Parameter Form	Notes
[SOURce] (cont'd) :SWEep :COUNt :DIRection :MODE :SPACing :TIME :VOLTage [:LEVel] [:IMMediate] [:AMPLitude] :OFFSet	<numeric_value> <UP DOWN> <CRESet TRESet HRESet CREVerse TREVerse HREVerse MANual> <LINear LOGarithmic> <numeric_value> <numeric_value> <numeric_value>	
SYSTem :CHECksum? :ERRor? :DATE :KEY :TEST? :REFerence :SOURce :TIME :TRIGger [:IMMediate] :LEVel :POLarity :TTL :VERSion? :ZAXis :LEVel :POLarity	<year>,<month>,<day> <numeric value> <INTernal EXTernal> <hour>,<minute>,<second> <numeric_value> <POSitive NEGative> <numeric_value> <POSitive NEGative>	
:SINTerface	<IEEE488 RS232>	
TEST<n> [:ALL]? :RAM? TRACe<n> :ADDRes? :CATalog? :DEFine TRACe<n> (cont'd) [:DATA] :LINE :POINt :DELete [:NAME] :ALL :DIRectory?	<trace_name>,(<trace_name> <numeric_value>) <trace_name>,(<trace_name> <block>) <trace_name>,<point_index1>,<point_value1>, <point_index2>,<point_value2> <trace_name>,<point_index>,<point_value> <trace_name>	

Table 5-1. SCPI Command Summary

Keyword	Parameter Form	Notes
:FREE? :LCONtiguous? :LIMits :MODE :POINts :REName :SElect	<trace_name>, <start_index>, <stop_index> <CW RASTer> <trace_name>, <numeric_value> <trace_name>, <trace_name> <trace_name>	
TRIGger<n> :COUNt :GATE [:STATe] [:IMMediate] :POLarity :SOURce [:STARt] :ADVance :TIMer	<numeric_value> <Boolean> <POSitive NEGative> <INTernal BUS EXTernal MASTer INPut0 INPut1 INPut2> <INTernal BUS EXTernal MASTer INPut0 INPut1 INPut2> <numeric_value>	
DISPlay TEXT CLEar UPDate	<string>	
HVOLTage<n> :OUTPut [:STATe] :CINPut [:STATe] :SUM [:LEVel] [:IMMediate] [:AMPLitude] :VERSion? :RESet	<Boolean> <Boolean> <Boolean>, <Boolean>, <Boolean> <numeric_value>	Option 007
STATus :OPERation :CONDition? :ENABle [:EVENT]? QUESTionable :OPERation :CONDition? :ENABle [:EVENT]? :PRESet	<numeric_value> <numeric_value>	

NOTE: The SCPI mandated IEEE-488 Common Commands are also part of the SCPI command set. See 'IEEE-488 Common Commands' at the end of this Section.

SCPI Command Tree

Appendix C shows an alternative method of illustrating the Model 295 SCPI commands. This is an inverted tree with the root node along the top of the diagram and the various branches along the bottom.

Command Message Format

The following paragraphs provide the programmer and operator with an introduction to the general rules that must be followed when sending SCPI messages. For an understanding beyond what is covered in this paragraph, refer to Appendix C and the appropriate SCPI and IEEE 488.2 documents.

Note

Programming errors are recorded by the SCPI parser. The programmer/operator must use the 'SYSTEM:ERROR?' query to review these errors.

Program Message Unit

The Program Header (command or query), previously defined as a complete single path to a leaf node, consists of one or more keywords separated by colons. It may also have a leading colon used to explicitly select the root node as the starting point. A Program Message Unit, <PMU>, consists of a Program Header followed (optionally) by Program Data.

Program Message

The Program Message consists of one or more <PMU>s delimited by semicolons and followed by a Program Message Terminator, <PMT>.

Program Message Delimiters

To piece together the Program Message, the SCPI parser expects commands and parameters in the correct order (Table 5-1) and separated by delimiters: colons (:), semicolons (;), spaces (), and comma (,). Use the colon to separate keywords within a Program Header, for example,

```
VOLT:LEV:IMM:AMPL 5
```

Do not insert spaces between keywords and colons. Placing the optional colon at the beginning of a Program Header ensures the parser starts from the "root" or top level. For example, a complete <PMU> with the leading colon is as follows:

```
:MODE CW
```

The leading colon at the beginning of any new message is unnecessary because the Program Message Terminator (<PMT>) at the end of the previous message resets the parser to the "root" node. The leading colon is not shown for most messages in this section. The semicolon is used as a Program Message Unit Separator (<PMS>). It permits multiple <PMU>s to be linked together in a single message. The colon may follow the semicolon to start the next <PMU> at the "root":

```
SOUR2:FREQ:CW 1E4;:MODE CW
```

Without the colon following the semicolon, the <PMU> must start within the same subsystem (at the same *node*) as the previous <PMU>:

```
SOUR2:FREQ:MODE SWE;STAR 1E3;STOP 1E5
```

A space separates the Program Header from its Program Data, as shown.

Program Data (Parameter Values) Forms

For the Model 295 and all instruments that use SCPI, program data may be in the form of a decimal numeric value (*numeric_data*), alpha characters (*character_data*), Boolean data, or Arbitrary Program Block Data (*block*). Examples of all four are:

```
FREQ 1000 (numeric_data)
MODE TRIG (character_data)
OUTP ON (Boolean_data)
CAL 1 :DATA <block> (block)
```

Notice that in all cases, a space separates the header from data. Numeric data values for most parameters may be in the form of an integer, a fixed or floating point value, or a special keyword as shown in the following:

<i>integer</i>	<i>fixed point</i>	<i>floating point</i>	<i>special form character</i>
FREQ 1000	FREQ 10.0	FREQ 10E3	FREQ MIN

When any of the three special form decimal <*numeric_value*> keywords, 'MINimum', 'MAXimum', or 'DEFault', are sent, the parameter being addressed is set to a predetermined <*numeric_value*>. The 'MAXimum' and 'MINimum' <*numeric_values*> are the upper and lower limit values of the parameter. The 'DEFault' <*numeric_value*> is within the limits of the parameter selected. Defaults values are printed in bold.

The Model 295 uses several character data keywords. These are shown in Table 5-1 and Appendix C.

Boolean data expresses an enabled ('on' or '1') or disabled ('off' or '0') state.

Program Message Terminators

The SCPI parser accepts New Line (NL), END, or NL with END as Program Message Terminator (<*pmt*>). However, the END (<EOI>) is the preferred <*pmt*> because it initiates an immediate transfer from the command/data buffer to the Language Processor for parsing. The other terminators may be delayed until the buffer fills.

Queries

Unless otherwise indicated, each header with a parameter form also has a query form so that the current setting may be reported back. A query is programmed by following the leaf node keyword with a question mark (?), no space. For example, send:

```
SOUR:FREQ:CW?
```

or the reduced form:

```
FREQ?
```

to query the frequency setting. The response for this query is a floating point

numerical value representing the frequency in Hertz. For example, if the response is 1 kHz, the returned value is:

1.000000E+03

For queries that include parameters, the question mark and a space are inserted prior to the parameter; for example:

FREQ? MAX

Some commands may exist in query form only, for example:

SYSTem:ERRor?

Some queries are mandated such as *ESE?, *SRE?, and *TST?; see "IEEE 488.2 Common Commands" in this section.

SCPI COMMANDS

The Model 295 is a multi-channel instrument. Because of this all root level subsystems except for SYSTem accept a numeric suffix, <n>. The MMEMory subsystem also has no numeric suffix at the root node, but the target channel number <n> is required in some of its parameter values (see Table 5-1). The numeric suffix specifies the channel number to which the program message is addressed. The following paragraphs describes the Model 295 SCPI program message set. Appendix C contains quick reference figure for each of the subsystems.

Note

Keywords followed by the numeric suffix <n> operate on one of the installed Channel cards rather than the "Instrument" level. If you do not include a number, the SCPI parser defaults to Channel number 1. Acceptable ARB Channel numbers for the suffix are 1, 2, 3, or 4. If the High Voltage Option - 007 is installed in Channel 4, the suffix for the ARB Channels ranges from 1 to 3. The Channel number (other than 1) must be given after the first root level keyword (with the numeric suffix) in each message. It is not necessary to send the numeric suffix more than once in a given message.

CALibration

CALibration<n>

[:ALL] ?

:DATA <block>

:AFCorrection <point>, <frequency>, <gain>

:AMPLitude

[:GAIN] <numeric_value>

:OFFSet <numeric_value>

:AMZero <numeric_value>

:OFFSet

[:GAIN] <POSitive | NEGative>, <numeric_value>

:OFFSet <POSitive | NEGative>, <numeric_value>

:PAZero <numeric_value>

:SCMZero <numeric_value>

:STORE

:SQRSymmetry <numeric_value>

:STATe <boolean>

CALibration<n> [:ALL] ?

Sending this program message performs a DC calibration of the output amplitude and offset voltage levels and stores the calibration data in non-volatile memory. The numeric suffix <n> identifies a Channel number. If the calibration is successful, use of the stored data is enabled for correction of programmed parameter values. If the calibration is unsuccessful for any reason, use of the stored data is disabled and default correction factors are used.

This query returns a value of 0 if the self-calibration is successful and a non-zero positive integer value if not. The response value will indicate the nature of the failure. The interpretation of the response value will be documented in the Maintenance Manual.

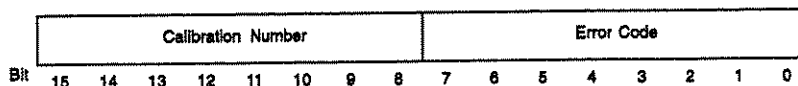

CALibration<n>(:ALL?) Response Format

CALibration<n>:DATA <block>

Sending this program message allows calibration data to be transferred directly to and from the memory on the Channel card in the form of Arbitrary Block Program Data. The CALibration:DATA:STORE program message must be used if data is to be transferred to the EEPROM. The format of this data will be documented in the Maintenance Manual.

CALibration<n>:DATA:AFCorrection <point>,<frequency>,<gain>

Sending this program message sets the amplitude gain correction for a specified frequency point. The value of "point" is an index into a table of gain corrections, and it should be an integer ranging from 0 to 5. Associated with each gain correction is the frequency at which the gain correction was calculated. The default table is shown below:

Frequency	Gain	Point
0 MHz	0	1.0
7 MHz	1	1.0
13 MHz	2	1.0
17 MHz	3	1.0
20 MHz	4	1.0
25 MHz	5	1.0

Internally the value of the gain parameter defaults to 1.0. Programmed gains should not be too far from this value. The gain and frequency parameters for points 0 and 5 should remain unchanged.

Between frequency points, linear interpolation is used to calculate the gain correction of the amplitude. The frequency points chosen correspond to the average position of the break points in the frequency response of the elliptic filter.

CALibration<n>:DATA:AFCorrection? <point>

Sending this query returns the contents of the amplitude correction table for the specified point. The response is in the format: <point>,<frequency>,<gain>.

CALibration<n>:DATA:AMPLitude[:GAIN] <numeric_value> (0.0)

Sending this program message directly sets the gain of the amplitude control DAC. This value is usually calculated by the self calibration, and has a DEFault and MINimum value of 0.0 and a MAXimum value of 1000. This value may also be queried.

CALibration<n>:DATA:AMPLitude:OFFSet <numeric_value> (2048)

Sending this program message directly sets the offset of the amplitude control. Self calibration usually calculates this value, which has a

Default value of 2048, a Minimum value of 0, and a Maximum value of 4095. This value is an integer and may also be queried.

CALibration<n>:DATA:AMZero <numeric_value> (2048)

Sending this program message directly sets the Amplitude Modulation Zero DAC. The numeric value is an integer value between 0 and 4095 corresponding to the range of the 12-bit DAC. This value defaults to 2048. Self calibration usually determines this value. This value may also be queried.

CALibration<n>:DATA:OFFSet[:GAIN] <Positive | Negative>,
<numeric_value> (0.0)

Sending this program message directly sets the gain of the output offset voltage control DACs. Self calibration usually calculates this value, which has a Default and Minimum value of 0.0 and a Maximum value of 1000. This value may also be queried.

CALibration<n>:DATA:OFFSet:OFFSet <Positive | Negative>,
<numeric_value> (2048)

Sending this program message directly sets the output offset voltage control offset. Self calibration usually calculates this value, which has a Default value of 2048, a Minimum value of 0, and a Maximum value of 4095. This value is an integer and may also be queried.

CALibration<n>:DATA:PAZero <numeric_value> (2048)

Sending this program message directly sets the DAC controlling the preamplifier zero correction. This parameter is an integer value between 0 and 4095 which corresponds to the range of the 12-bit DAC. This value defaults to 2048. Self calibration usually determines this value, which may also be queried.

CALibration<n>:DATA:SCMZero <numeric_value> (2048)

Sending this program message directly sets the DAC controlling the Suppressed Carrier Modulation Zero. The parameter is an integer value between 0 and 4095 corresponding to the range of the 12-bit DAC. This value defaults to 2048, and may be queried.

CALibration<n>:DATA:STORE

Sending this program message causes correction data that has been downloaded using the program messages in the CALibrate:DATA subsystem to be stored into non-volatile memory. This should be done only after all correction data has been finalized so as to minimize writes to the EEPROM.

CALibration<n>:DATA:SQRSymmetry <numeric_value> (2606)

Sending this program message directly sets the correction for the DAC controlling the high frequency square wave symmetry. The parameter is an integer value between 0 and 4095 corresponding to the range of the 12-bit DAC. This value defaults to 2606, and may be queried.

CALibration<n>:STATE <ON | OFF>

Sending this program message enables correction of the output amplitude and offset voltage levels using the calibration data stored in non-

volatile memory. If the calibration corrections are disabled then default corrections are used.

INITiate<n>

```
INITiate<n>  
  [:IMMediate]  
  :CONTInuous <Boolean>
```

```
INITiate<n>[:IMMediate]
```

This program message supports the SCPI language definition, but changes no setups within the Model 295.

```
INITiate<n>:CONTInuous <ON | OFF>
```

Sending this program message selects between continuous mode of operation and a non-continuous mode of operation. In continuous, the selected trace or function is continuously output at the Channel <n> Main Out, using the (default) command:

```
INIT<n>:CONT ON
```

Non-continuous modes include Triggered and Gated modes. Triggered mode outputs the selected trace or function for a number of cycles determined by the trigger COUNT once per triggering event at the Channel <n> Main Out, using the command:

```
INIT<n>:CONT OFF; :TRIG:GATE OFF; :TRIG:COUN <value>
```

Gated mode causes the selected function or trace to be output while the trigger source is true, and quiescent while the source is false. There are two GATE sub-modes, as shown in the command:

```
INIT<n>:CONT OFF; :TRIG:GATE ON;MODE <ASYN | SYNC>
```

MMEMemory

Mass Memory subsystem is active in all units. However, DISK is valid only on units that contain the optional 3-1/2 inch disk drive. The program messages under this subsystem allow access to the optional disk drive from the remote interface.

```
MMEMemory
```

```
:CATalog? <RAM|DISK>  
:COPY <source_name>, <RAM|DISK>, <dest_name>, <RAM|DISK>  
:DELete <file_name>, <RAM|DISK>  
:INITialize <RAM|DISK>  
:LOAD  
  :SETup <setup_name>, <RAM|DISK>  
  :SEQUence <n>, <sequence_name>, <RAM|DISK>  
  :TRACe <n>, <trace_name>, <RAM|DISK>  
:STORE  
  :SETup <setup_name>, <RAM|DISK>  
  :TRACe <n>, <trace_name>, <dest_name>, <RAM|DISK>
```

MMEMemory:CATalog? <RAM|DISK>

Sending this query returns the CATalog listing of either the Battery-Backed RAM in the instrument, or the floppy diskette in the 3-1/2 inch drive. Returned format is <bytes_used>,<bytes_free>,name,size,name,size,...

MMEMemory:COpy <source_name>,<RAM|DISK>,<dest_name>,<RAM|DISK>

Sending this command causes the file with the *source_name* (on Battery-Backed RAM or on the floppy diskette) to be copied with the given *dest_name* (to Battery-Backed RAM or to the floppy diskette). The *source_name* has to be of the form <name.ext>, where *ext* is the three letter extension for a disk file (*.wfm*, *.seq*, *.arb*, or *.scf*). The *dest_name* does not require the extension, but it can be provided. An example command follows:

MMEMemory:COpy wave1.wfm,disk,wave2,ram

MMEMemory:DELEte <file_name>,<RAM|DISK>

Sending this command causes the selected *file_name* (on Battery-Backed RAM or on the floppy diskette) to be deleted. As with COPY, the file name must include an extension to uniquely identify that file.

MMEMemory:INITialize <RAM|DISK>

Formats a floppy diskette, or entirely clears out the Battery-Backed RAM. Prepares them for uses as Mass MEMORY. Disk format takes around 3 minutes; RAM initialization takes a fraction of a second.

MMEMemory:LOAD:SETup <setup_name>,<RAM|DISK>

Loads Stored Setup file *name.scf* from Battery-Backed RAM or the floppy diskette into the instrument and makes it the current Setup. Equivalent to using the IEEE-488 *RCL command, except that the <setup_name> is a character string rather than numeric. This command can load a setup file created by *RCL by internally supplying an "S" prefix. Example:

*RCL 17234

is equivalent to:

MMEMemory:LOAD:SET S17234,RAM

MMEMemory:LOAD:SEquence <n>,<sequence_name>,<RAM|DISK>

Loads Sequence file *name.seq* from Battery-Backed RAM or the floppy diskette to Channel <n> and executes it.

MMEMemory:LOAD:TRACe <n>,<trace_name>,<RAM|DISK>

Loads waveform file *name.wfm* from Battery-Backed RAM or the floppy diskette (could also be *name.arb* from disk) into trace memory of Channel <n>, and makes it the currently executing waveform.

MMEMemory:STORe:SETup <setup_name>,<RAM|DISK>

Stores the instrument's current settings as a Stored Setup file *name.scf* to the Battery-Backed RAM or to the floppy diskette. Equivalent to using the IEEE-488 *SAV command, except that the <setup_name> is a character string rather than numeric. Example:

*SAV 32

is equivalent to:

MME:STOR:SET S32, RAM

MMEMory:STORe:TRACe <n>, <trace_name>, <dest_name>, <RAM|DISK>

Stores the waveform trace currently active on Channel <n> to waveform file *name.wfm* on the Battery-Backed RAM or on the floppy diskette.

OUTPut<n>

OUTPut<n>

:CLOCK

:FREQUency <numeric_value>

:MASTer

:SOURce <INTernal | EXTernal>

[:STATe] <Boolean>

:SOURce <RASTer | SYNThesizer>

[:STATe] <Boolean>

:FILTer

[:LPASs]

[:STATe] <Boolean>

:SELEct <ELLiptic | BESSEl>

[:STATe] <Boolean>

:SUMBus

[:STATe] <Boolean>

:TRIGger

[:STATe] <Boolean>

:SOURce <BIT | BCOMplete | LCOMplete>

OUTPut<n>:CLOCK:MASTer[:STATe] <ON | OFF>

Sending this program message enables the clock output to the backplane.

OUTPut<n>:CLOCK:MASTer:SOURce <INTernal | EXTernal>

Sending this program message selects the source of the clock output to the backplane.

- INTernal Source from the internal frequency synthesizer.
- EXTernal Source from the CLOCK IN BNC.

OUTPut<n>:CLOCK:FREQUency <numeric_value> (1e3)

Sending this program message sets up the CLOCK BNC as an output sourcing a clock signal with the specified frequency. The output clock frequency ranges from 1e-1 to 1e8 Hz, with 1e3 as the default value. This program message causes all other outputs to be turned off and completely reconfigures the internal state of the instrument to support this mode of operation.

OUTPut<n>:CLOCK[:STATe] <ON | OFF>

Sending this program message enables the clock output to the BNC.

OUTPut<n>:CLOCK:SOURce <RASTer | SYNThesizer>

Selects the source of the clock output to the BNC

• **RASTer** Raster clock. When the trace mode is set to raster using the program message:

TRACe:MODE RASTer

then the raster frequency can be programmed using the program message:

[SOURce<n>:]FREQUency:RASTer
<numeric_value>

• **SYNThesizer** Direct output of frequency synthesizer. The frequency of this signal is twice the programmed raster clock frequency when the raster clock frequency ranges between 25 and 50 MHz. When the raster frequency is less than 25 MHz then the synthesizer frequency is undetermined.

OUTPut<n>:FILTer[:LPASS][:STATe] <ON | OFF>

Sending this program message enables the 20 MHz low pass filter between the output of the waveform DAC and the pre-amplifier.

OUTPut<n>:FILTer[:LPASS][:STATe] ?

Sending this query returns a numeric value indicating the enable state of the filter.

OUTPut<n>:FILTer[:LPASS]:SElect <ELLiptic | BESSel>

Sending this program message selects the filter type.

- **BESSel** Selects the Bessel filter.
- **ELLiptic** Selects the elliptic filter.

OUTPut<n>[:STATe] <ON | OFF>

Sending this program message controls the state of the function output relay.

OUTPut<n>:SUMBus[:STATe] <ON | OFF>

Sending this program message enables analog sum output to the backplane.

OUTPut<n>:TRIGger[:STATe] <ON | OFF>

Sending this program message enables the trigger output to the backplane.

OUTPut<n>:TRIGger:SOURce <BIT | BCOMplete | LCOMplete>

Selects the trigger output source.

- **BIT** Selects a signal driven by the trigger marker bit in Trace RAM.
- **BCOMplete** Selects the Burst Complete signal.
- **LCOMplete** Selects the Loop Complete signal.

OUTPut<n>:TRIGger[:STATe] <ON | OFF>

Sending this program message connects the trigger output to the instrument's backplane.

RESet<n>

RESet<n>

RESet<n>

Sending this program message resets all parameters of Channel <n> to their default state. This program message has no effect on the TRACe

subsystem. Following is a list of Model 295 defaults:

Amplitude	1.0 Vp
AM Mode	AM
Frequency	1kHz
AM State	Off
Channel Clock	Independent
Clock Output	Off
Clock Out Source	Raster Clock
Filter	Elliptic
Function Mode	Fixed
Function Shape	Sine
Marker Position	0
Master Clock Source	Internal
Mode	Continuous
Offset	0.0 Vdc
Output	Off
Phase Shift	0.0°
Reference Source	External
Sequence Trigger	Edge
Sequence Trigger Advance	Automatic
Sweep Direction	Up
Sweep Mode	Continuous Reset
Sweep Spacing	Linear
Sweep Start	1kHz
Sweep Stop	10 kHz
Sweep Time	1 second
Sync Source	Zero Crossing
Sync Output	Off
System Trigger Level	TTL
System Trigger Polarity	Positive
Trigger Count	1
Trigger Rate, Internal	1kHz
Trigger Source	Internal
Z-Axis Level	0
Z-Axis Polarity	Positive

(SOURCE<n>)

```
[SOURCE<n>]
:AM
:STATE <Boolean>
:MODE <AM | SCM>
:CLOCK
:CONFIGure <INPUT | OUTPUT>
:FREQUENCY
[:CW | FIXed] <numeric_value>
:MANual <numeric_value>
:MODE <CW | FIXed | SWEEp>
:RASTer <numeric_value>
:START <numeric_value>
:STOP <numeric_value>
:FUNCTION
[:SHAPE] <shape_name>
```

```

:USER <trace_name>
:MODE <FIXed | SEquence>
:GROup <numeric_value>
:MARKer
:POSition
:AOFF <trace_name>
:POINT <trace_name>,<point_index>
:ZAXis
:AOFF <trace_name>
:POINT <trace_name>,<point_index>
:SYNC
:SOURce <ZCRoss | BBITs>
[:STATe] <Boolean>
:TRIGger
[:STATe] <trace_name>,<Boolean>
:PHASe
[:ADJust] <numeric_value>
:MODE <INdependent | MASTER | SLAVE>
:ROSCillator
:SOURce <INTernal | EXTernal | BUS>
:SEquence
:ADVance <AUTOMATIC | TRIGgered>,<list_index>
:DWELl <numeric_value>,<list_index>
:FUNCTion <trace_name>,<list_index>
:LENGth <numeric_value>
:TRIGger
:SENSe <EDGE | LEVEL>
:MODE <SYNchronous | ASYNchronous>
:SUMBus
[:STATe] <Boolean>
:ATTenuation <numeric_value>
:SWEep
:COUNT <numeric_value>
:DIRection <UP | DOWN>
:MODE <CRESet | TRESet | HRESet | CREVerse |
TREVerse | HREVerse | MANUAL>
:SPACing <LINear | LOGarithmic>
:TIME <numeric_value>
:VOLTagE
[:LEVEL]
[:IMMediate]
[:AMPLitude] <numeric_value>
:OFFSet <numeric_value>

```

Note

The SCPI language considers SOURce to be a default program message. However, sending SOURce with a number <n> at the beginning of a message defines the Channel (Channel 1 is the default).

[SOURce<n>:]AM:STATe <ON | OFF>

Sending this program message enables or disables the amplitude modulation input.

[SOURce<n>:]AM:MODE <AM | SCM>

Sending this program message selects the amplitude modulation mode.

- AMStandard amplitude modulation.
- SCMSuppressed carrier amplitude modulation.

[SOURce<n>:]CLOCK:CONFIgure <INPut | OUTPut>

Sending this program message configures the use of the CLOCK BNC.

[SOURce<n>:]FREQuency[:CW] <numeric_value> (1.0e3)

Sending this program message controls the frequency of the function output when the Trace Mode is set to CW. This message controls the frequency of only standard waveforms: see SOURce:FUNCTion:SHAPE. Allowable values are 1e-6 to 2.5e7.

[SOURce<n>:]FREQuency:MANual <numeric_value> (1.0e3)

Sending this program message controls the frequency of the function output when [SOURce:]FREQuency:MODE SWEEp and [SOURce:]SWEEp:MODE MANual are selected. Allowable range is 1e-1 to 2e7.

[SOURce<n>:]FREQuency:MODE <CW | SWEEp>

Sending this program message controls the frequency sweep logic. If the frequency mode is set to CW then the output frequency of a standard function is determined by the programming of [SOURce:]FREQuency[:CW]. If the frequency mode is set to SWEEp then the output frequency is swept from the start frequency to the stop frequency in the direction and time set by the sweep sub-system program messages.

[SOURce<n>:]FREQuency:START <numeric_value> (1.0e3)

Sending this program message controls the start frequency of the function output when the frequency mode is set to SWEEp. Allowable range is 1e-1 to 2e7.

[SOURce<n>:]FREQuency:STOP <numeric_value> (1.0e5)

Sending this program message controls the stop frequency of the function output when the frequency mode is set to SWEEp. Allowable range is 1e-1 to 2e7.

[SOURce<n>:]FREQuency:RASTer <numeric_value> (5.0e7)

Sending this program message controls the trace scan rate when the Trace Mode is set to RASTer. This message controls the frequency of standard waveforms: see SOURce:FUNCTion:USER. Allowable range is 1e-1 to 5e7.

[SOURce<n>:]FUNCTion:MODE <FIXed | SEQuence>

Sending this program message controls the function sequence logic. If

the function mode is set to FIXed then the output function is [SOURCE:]FUNCTION[:SHAPE]. If the function mode is set to SEQUENCE then the output function is determined by the contents of the sequence table.

[SOURCE<n>:]FUNCTION[:SHAPE] <source_shape>

Sending this program message selects the shape of the output signal. Set the frequency of the Shape using [SOURCE<n>:]FREQUENCY[:CW] <numeric_value>. For all functions except USER the Model 295 automatically sets the following parameters. You may change these settings after selecting the function:

TRACe:MODE CW

[SOURCE:]MARKer:SYNC:SOURCe ZCRoss

OUTPut:FILTer ON

For the function: USER the Model 295 automatically sets the following parameters:

TRACe:MODE RASTer

[SOURCE:]MARKer:SYNC:SOURCe BBITs

OUTPut:FILTer OFF

The following function shapes are available:

- DCAn unvarying signal with respect to time.
- HFSquare High frequency square wave. This square wave has faster rise and fall times than the standard square wave. Its maximum frequency is 25 MHz.
- NHSine Negative haversine.
- NRAMp Negative ramp.
- PHSine Positive haversine.
- PRAMp Positive ramp.
- PRNoise Periodic random noise.
- SINusoid A sinusoidal signal.
- SQUare A square wave signal.
- TRIangle A triangle wave signal.
- USERSelects the user defined function specified by the SOURCE:FUNCTION:USER program message. Selecting a user function automatically switches the method of waveform generation to raster scan.

[SOURCE<n>:]FUNCTION:USER <trace_name>

Sending this program message selects one of the user functions defined under the TRACe subsystem. The user function will be output only if USER is selected by the [SOURCE:]FUNCTION[:SHAPE] program message. Set the sample clock using [SOURCE<n>:]FREQUENCY:RASTer <numeric_value>.

[SOURCE:]GROUp <numeric_value> (0)

Sending this program message allows commands sent to Arb Channel 1 to drive multiple Arb channel Cards. Using this program message causes commands sent to channel 1 to act as if they were sent to all grouped channels simultaneously. The <numeric_value> is the Group Code integer in the range of 0 to 7 which specifies the channels for each group.

Group Code	Channels
0	1
1	1, 2
2	1, 3
3	1, 2, 3
4	1, 4
5	1, 2, 4
6	1, 3, 4
7	1, 2, 3, 4

[SOURCE<n>:]MARKer:POSition:AOff <trace_name>

Sending this program message sets all POSITION marker bits to the inactive state. There is no query form for this program message.

[SOURCE<n>:]MARKer:POSition:POINT <trace_name>, <point_index>

Sending this program message sets the POSITION marker at the specified point within the specified trace to the active state. There is no query form for this program message. "Point index" is an integer value.

[SOURCE<n>:]MARKer:SYNC[:STATe] <ON | OFF>

Sending this program message enables the SYNC marker output. This program message will be accepted but will not perform any function since there is no way to disable this output.

[SOURCE<n>:]MARKer:SYNC:SOURce <ZCROSS | BBITs>

Sending this program message selects the method used to generate the SYNC marker output.

- ZCROSS Selects the output of a comparator. The comparator output is high if the output signal amplitude is above 0 volts and low if the output signal amplitude is below 0 volts.
- BBITs Marker signal is driven from a bit in Trace RAM. The bit is set so the marker is active for the first several points of the trace.

[SOURCE<n>:]MARKer:TRIGger[:STATe] <trace_name>, <ON|OFF>

The Trigger Marker is an internal signal generated to condition selected trigger outputs. The trigger outputs are selected under the OUTPUT:TRIGger sub-system. This command selects which trace(s) will generate Trigger Markers, and thus trigger outputs.

[SOURCE<n>:]MARKer:ZAXis:AOff <trace_name>

Sending this program message sets all ZAXIS marker bits to the inactive state. There is no query form for this program message.

[SOURCE<n>:]MARKer:ZAXis:POINT <trace_name>, <point_index>

Sending this program message sets the ZAXIS marker at the specified point within the specified trace to the active state. There is no query form for this program message. "Point index" is an integer value.

[SOURCE<n>:]PHASe[:ADJust] <numeric_value> (0.0)

Sending this program message controls the phase of the output relative to the current phase. The parameter has units of degrees. The Phase value ranges from -180 to +180, with 0 as the default value.

[SOURCE<n>:]PHASe:MODE <INdependent | MASTER | SLAVE>

Sending this program message controls the use of the phase reference signals on the backplane. In order for two or more channels to be phase

locked they must have waveform traces of the same size running at the same frequency. All channels must source the reference oscillator from the backplane. This is done by using the program message:

[SOURCE<n>:]ROSCillator:SOURCE BUS

The master channel must have its clock output to the backplane enabled. This is done by using the program message:

OUTPUT<n>:CLOCK:MASTER[:STATE] ON

The PHASE MODE parameters for Channel <n> are defined as:

- **INDEPENDent**The phase reference signals on the backplane are not used by Channel <n>.
- **MASTERChannel <n>** outputs its phase reference signals to the backplane to be used by slave channels as a phase reference.
- **SLAVEChannel <n>** uses the phase reference signals on the backplane from the master channel as a phase reference.

[SOURCE<n>:]ROSCillator:SOURCE <INTERNAL|EXTERNAL|BUS>

Sending this program message selects the source of the reference oscillator.

- **INTERNAL**Selects the output of an internal frequency synthesizer.
- **BUS**Selects the clock signal from the backplane.
- **EXTERNAL**Selects the input signal from the CLOCK IN/OUT BNC. This BNC must be configured as an input using the program message:

[SOURCE:]CLOCK:CONFIGuration INPUT

[SOURCE<n>:]SEQUence:ADVance <AUTOMATIC|TRIGGERed>,<index>

Sending this program message select the conditions which causes a sequence to advance to the next waveform segment.

- **AUTOMATIC**Automatically advances to the next segment in the sequence after the repeat count.
- **TRIGGERed**Waits for a trigger "event" after the repeat count before advancing to the next segment in the sequence.

[SOURCE<n>:]SEQUence:FUNCTION <trace_name>,<index>

Sending this program message defines a list of user-defined waveforms which are to be sequenced through when the function is set to SEQUENCE. The "index" value sequentially points to each waveform segment in the sequence, from 0 up to a maximum of 3. "0" is the first segment.

[SOURCE<n>:]SEQUence:DWELL <numeric_value>(1),<index>

Sending this program message defines the number of times to repeat each one of the waveform segments in the sequence. There is a one-to-one correspondence between waveform segments in the function list and repeat counts in the dwell list. The 'DEFAULT' value is 1, and the 'MAXimum' value is 65,535. "Index" is the segment index, ranging from 0 to 3, with "0" being the first segment. Sending a dwell of "0" repeats the Arb waveform until the unit receives an advance trigger. When dwell = 0, SEQUENCE:TRIGGER must be set to triggered.

[SOURCE<n>:]SEQUence:LENGTH <numeric_value> (2)

Sending this program message defines the number of waveform segments the sequence and the maximum "index" value for the other

Sequence commands. The 'MINimum' and 'DEFault' values are 2 and the 'MAXimum' value is 4.

[SOURCE<n>:] SEQUENCE:TRIGGER:SENSE <EDGE | LEVEL>

Sending this program message defines the active portion of the trigger signal. The trigger "event" advances the sequence from one waveform segment to the next if the ADVance condition is set to TRIGGERed.

- **EDGE**The rising edge of the trigger signal initiates the trigger event.
- **LEVEL**The trigger event is true as long as the trigger level is held true.

[SOURCE<n>:] SEQUENCE:TRIGGER:MODE <SYNchronous | ASYNchronous>

Sending this program message defines the transition mode from the current waveform segment to the next waveform segment in the sequence after receiving a trigger "event". Valid if the ADVance condition is set to TRIGGERed.

- **SYNchronous**Wait until the end point of the current waveform segment before selecting the next segment in the sequence.
- **ASYNchronous**Immediately selects the next waveform segment in the sequence.

[SOURCE<n>:] SWEEP:COUNT <numeric_value> (1)

Sending this program message determines the number of sweeps which are enabled by a single trigger event. The SWEEP MODE must be non-continuous. 'MINimum' and 'DEFault' values are 1, 'MAXimum' value is 1,000,000.

[SOURCE<n>:] SWEEP:DIRection <UP | DOWN>

Sending this program message controls the sweep direction. If UP is selected the sweep is performed in ascending order from START to STOP. If DOWN is selected the output frequency is swept from STOP to START.

[SOURCE<n>:] SWEEP:MODE <CRESet | TRESet | HRESet | CREVerse | TREVerse | HREVerse | MANual>

Sending this program message sets the mode of the sweep. The sweep modes have the following characteristics:

- **CRESet** Sweeps from the start frequency to the stop frequency and then returns to the start frequency in a continuous loop.
- **TRESet** Waits for a trigger and then sweeps from the start frequency to the stop frequency and then resets to the start frequency.
- **HRESet** Waits for a trigger and then sweeps from the start frequency to the stop frequency and then waits for another trigger before returning to the start frequency.
- **CREVerse** Sweeps from the start frequency to the stop frequency and then sweeps back to the start frequency in a continuous loop.
- **TREVerse** Waits for a trigger and then sweeps from the start frequency to the stop frequency and then sweeps back to the start frequency.

- **HREVerse** Waits for a trigger and then sweeps from the start frequency to the stop frequency and then waits for another trigger before sweeping back to the start frequency.
- **MANual** Uses the frequency set by the [SOURCE<n>:]FREQUENCY:MANual program message if it is within the range of frequencies set by the [SOURCE<n>:]FREQUENCY:START and [SOURCE<n>:]FREQUENCY:STOP program messages.

[SOURCE<n>:]SWEep:TIME <numeric_value> (1.0)

Sending this program message sets the duration of the sweep in seconds. The sweep time may range from 30 ms to 1000s.

[SOURCE<n>:]SWEep:SPACing <LINear | LOGarithmic>

Sending this program message determines the frequency verses time characteristics of the sweep.

- **LINear** Output frequency is swept linearly between the START and STOP frequencies.
- **LOGarithmic** Output frequency is swept on a logarithmic curve fitted between the START and STOP frequencies. The objective of the logarithmic sweep is to spend equal amounts of time within each decade of frequency.

[SOURCE<n>:]SUMBus[:STATe] <ON | OFF>

Sending this program message enables the analog sum input from the backplane.

[SOURCE<n>:]SUMBus:ATTenuation <numeric_value> (0)

Sending this program message controls the level of attenuation in the path of the analog sum input from the backplane. This program message accepts an integer value in the range 0 to 42 and rounds the value down to one of the following attenuation levels: 0 dB (+1), 6 dB (+2), 12 dB (+4), 18 dB (+8), 24 dB (+16), 30 dB (+32), 36 dB (+64), 42 dB (+128).

[SOURCE<n>:]VOLTage[:LEVel][:IMMediate]:OFFSet
<numeric_value> (0.0)

Sending this program message controls the level of the output offset voltage. 'MINimum' offset is -7.5 Vdc, 'MAXimum' offset is +7.5 Vdc.

[SOURCE<n>:]VOLTage[:LEVel][:IMMediate]:AMPLitude
<numeric_value> (1.0)

Sending this program message sets the absolute value of the maximum amplitude voltage. The amplitude voltage is at maximum when the selected trace point is at its minimum or maximum value. The value of a point in trace memory affects the output amplitude in the manner shown in the following diagram.

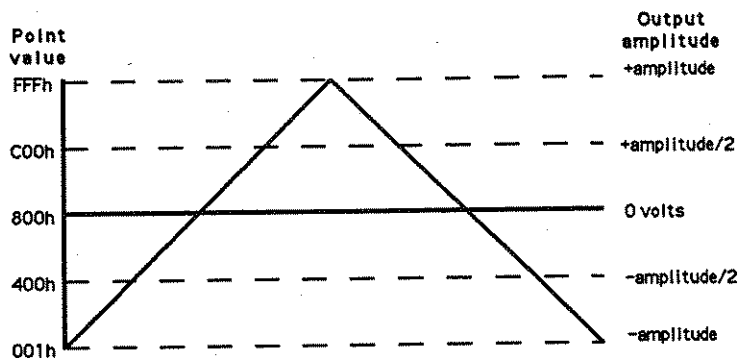

Each point in Trace Memory contains a value in the range 000h (0) to FFFh (4095). As Trace Memory is scanned these values are converted to analog voltages for output. The Arb Channel is calibrated so that the value 800h corresponds to 0 volts amplitude and the values 001h and FFFh corresponds to the negative and positive full scale amplitude voltages.

Because of the way in which the Arb Channel is calibrated, the point value 000h will generate an output voltage slightly more negative than the programmed amplitude. Limit your point values to the range 001h to FFFh if you want trace amplitudes to be symmetrical about 0 volts.

All internally generated traces of a cyclical nature (SINusoid, SQUare, TRIangle, ... etc.) are generated such that their most negative point has a value of 001h and their most positive point has a value of FFFh. This makes their amplitude voltages symmetrical about 0 volts and the absolute value of their peak voltages equal to the programmed amplitude. The 'MINimum' amplitude is 0.0 Vpk, the 'MAXimum' amplitude is 7.5 Vpk.

SYSTEM

SYSTEM

```

:CHECKsum?
:ERRor?
:DATE <year>, <month>, <day>
:KEY <numeric value>
:REFerence
    :SOURce <INTernal | EXTernal>
:TEST?
:TIME <hour>, <minute>, <second>
:TRIGger
    [:IMMediate]
    :LEVel <numeric_value>
    :POLarity <POSitive | NEGative>
    :TTL
:VERsion?
:ZAXis
    :LEVel <numeric_value>
    :POLarity <POSitive | NEGative>

```

SYSTEM:CHECKsum?

Sending this query returns the checksum of the ROM on the CPU card. The checksum is computed by summing the values of every byte into a 16-bit value. The Model 295 returns the checksum as a four character hexadecimal value.

SYSTEM:ERRor?

Sending this query returns the next message from the system error queue.

SYSTEM:DATE

Used to set or query the system's date using the following format:

<yyyy>,<mm>,<dd>

At each power-on, the date is set to January 1, 1992.

SYSTEM:KEY <numeric value>

Sending this program message remotely simulates the pressing of a front panel key. The numeric value is a decimal value representing a front panel key.

Front Panel Key	Numeric Value
SELECT	9
LCD/SCOPE	134
MENU	12
SOFT KEY 1	1
SOFT KEY 2	2
SOFT KEY 3	3
SOFT KEY 4	4
SOFT KEY 5	5
SOFT KEY 6	6
TRIGGER	133
SEQUENCE	135
INSTRUMENT	136
UTILITY	137
WAVEFORM	138
CHANNEL	139
MANUAL TRIGGER	140
UP	94
RIGHT	62
LEFT	60
DOWN	33
BACKSPACE	8
CLEAR	27
ENTER	13
0	48
1	49
2	50
3	51
4	52
5	53

6	54
Front Panel Key	Numeric Value
7	55
8	56
9	57
PLUS	43
MINUS	45
MULTIPLY	42
DIVIDE	47
PERIOD/POINT	46
COMMA	44
LEFT PARENTHESIS	40
RIGHT PARENTHESIS	41
EXPONENT	11

SYSTem:REfERENCE:SOURce <INTernal | EXTernal>

Sending this program message elects the source of the system reference clock.

- INTernal Selects the on board 10 MHz TCXO.
- EXTernal Selects the signal at the CLOCK IN BNC.

SYSTem:TIME

Used to set or query the system's time using the following format:

<hh>,<mm>,<ss>

where <hh> ranges from 00 to 23 (a 24 hour time clock). Time is set to 00:00:00 at each power-on.

SYSTem:TRIGger[:IMMediate]

Sending this program message pulses the system trigger line on the back plane.

SYSTem:TRIGger:LEVel <numeric_value> (2.0)

Sending this program message sets the system trigger threshold to a value between 0 and 10 volts.

SYSTem:TRIGger:TTL

Sending this program message sets the trigger level to a value appropriate for TTL level signals (2.0 volts).

SYSTem:ZAXis:LEVel <numeric_value> (0)

Sending this program message sets the output level of the z-axis marker by programming the z-axis level control DAC. The DAC accepts integer values between 0 and 255.

SYSTem:ZAXis:POLarity <POSitive | NEGative>

Sending this program message sets the polarity of the z-axis marker. The z-axis marker enables the z-axis output.

TEST<n>

TEST<n>

[:ALL]?

:RAM?

TEST<n>[:ALL]?

Sending this query performs a test on the Channel hardware. A result of zero is returned if the test passed. A non-zero result is returned if the

test failed. Interpretation of the result code will indicate the nature of the error. The format of the 16-bit result code is shown below:

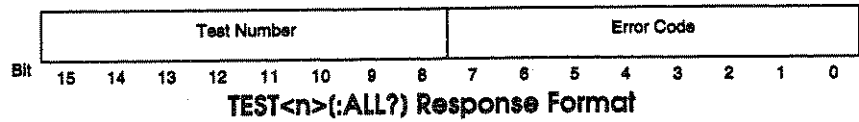

The upper 8-bits of the result code contain the sub-test number in which a failure was detected. The lower 8-bits contain a bit-weighted error code that indicate the exact cause of the failure. The sub-tests and the meaning of their error code are documented in the Maintenance Manual.

TEST<n> : RAM?

Sending this query performs a destructive test of the Trace RAM. A result of zero is returned if the test passed. A non-zero result is returned if the test failed. Interpretation of the 16-bit result code will indicate the nature of the error. Bits 15 and 14 encode the sub-test number on which the first failure was detected. The interpretation of the rest of the bits in the response depends on the sub-test, and is documented in the Maintenance Manual.

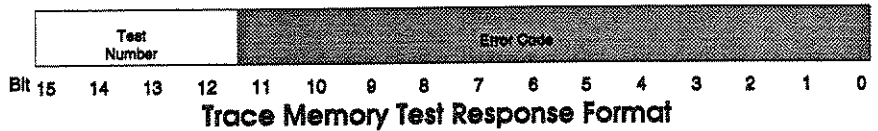

TRACe<n>

TRACe<n>

- :ADDRESS?
- :CATalog?
- :DEFine <trace_name>, (<numeric_value> | <trace_name>)
- [:DATA] <trace_name>, (<block> | <trace_name>)
- :LINE <trace_name>, <point_index1>, <point_value1>, <point_index2>, <point_value2>
- :POINT <trace_name>, <point_index>, <point_value>
- :DELete
- [:NAME] <trace_name>
- :ALL
- :DIRectory?
- :FREE?
- :LCONTiguous
- :LIMits <trace_name>, <start_index>, <stop_index>
- :MODE <CW | RASTer>
- :POINTs <trace_name>, <numeric_value>
- :REName <trace_name>, <trace_name>
- :SELect <trace_name>

TRACe<n>:DEFine <trace_name>, (<numeric_value> | <trace_name>)

Sending this program message creates a new trace with the name specified by the first parameter. The second parameter may be a numeric value indicating

the size of the new trace or the name of another trace. If the second parameter is the name of a trace, the new trace is created as an exact duplicate (except for its name) of the specified trace.

TRACe<n>[:DATA] <trace_name>, (<block> | <trace_name>)

Sending this program message initializes the contents of the trace whose name is specified by the first parameter. The second parameter may be binary data in Definite Length Arbitrary Block Data** format, the name of a Standard Function, or the name of another trace. This program message only operates on the portion of the trace set by the trace limits. If the second parameter is a trace or Function name, that function is mapped to fill the first parameter trace name. If the second parameter is a trace and it has more points than the destination trace, points are discarded during the copy in a fashion that preserves the wave shape as much as possible.

TRACe<n>[:DATA]? <trace_name>

Sending this query returns the contents of the trace whose name is specified by the first parameter in Definite Length Arbitrary Block Data** format. Only the data contained in the portion of the trace set by the trace limits is returned.

*** See "High Speed Binary Data Transfer" at the end of this Section for more information on the Definite Length Arbitrary Block Data format.*

TRACe<n>[:DATA]:LINE <trace_name>, <point_index1>,
<point_value1>, <point_index2>, <point_value2>

Sending this program message draws a line segment within the boundaries of the trace whose name is specified by <trace_name>. <point_index1> is the integer index of the start point and <point_value1> is its decimal value. <point_index2> is the index of the end point and <point_value2> is its value. A line is drawn connecting the start point and end point. The first point index in a trace is zero. Point values can range from 0 to 4095.

TRACe<n>:DATA:POINT <trace_name>, <point_index>,
<point_value>

Sending this program message sets the point specified by <point_index> in the trace specified by <trace_name> to the value specified by <point_value>. The point index is an integer ranging from 0 (the first point) to the trace size minus one. The point value is an integer ranging from 0 to 4095.

TRACe<n>:DATA:POINT? <trace_name>, <point_index>

Sending this query returns the value of the point specified by <point_index> in the trace specified by <trace_name>. The point index is an integer ranging from 0 (the first point) to the trace size minus one. The point value is an integer ranging from 0 to 4095.

TRACe<n>:LIMITS <trace_name>, <start_index>,
<stop_index>

Sending this program message sets the playback limits of the trace whose name is specified by <trace_name>. The second parameter is the index of the start point and the third parameter is the index of the end

point. The value of the end point must be greater than the value of the start point plus eight. Both points must be within the trace boundaries. Trace boundaries range from 0 to size -1.

TRACe<n>:LIMits? <trace_name>

Sending this query returns the playback limits of the trace whose name is specified by <trace_name> in the following format:

<start_index>, <stop_index>

TRACe<n>:MODE <CW | RASter>

Sending this program message sets the trace playback mode. If CW is selected, a fixed 50 MHz scan rate is used and phase accumulation is used for frequency control. Frequency is controlled using the :FREQuency[:CW] program message. CW stands for Continuous Wave and implies the signal being played back is phase continuous like a sine wave. CW mode is useful primarily for playing back standard functions like sinusoid, triangle and square. Because of the fixed scan rate the 20 MHz filter can be turned on to remove the 50 MHz sampling noise and thus generate spectrally pure functions.

If RASter is selected the scan rate can be adjusted by the selected reference oscillator. The raster scan frequency is controlled by the :FREQuency:RASter program message. Raster mode would be used to play back arbitrary waveforms which typically define a complex pattern of amplitude verses time. The user may not want to use the filter in this mode because they may be generating stair step or pulse patterns that are meant to have sharp edges.

TRACe<n>:POINts <trace_name>, <numeric_value>

Sending this program message resizes the trace whose name is specified by <trace_name>. The new size is specified by the second integer parameter.

TRACe<n>:POINts? <trace_name>

Sending this query returns the size of the specified trace.

TRACe<n>:DELEte[:NAME] <trace_name>

Sending this program message deletes the specified trace.

TRACe<n>:DELEte:ALL

Sending this program message deletes all traces.

TRACe<n>:CATalog?

Sending this query returns a string containing the names of all defined traces. Trace names are separated by commas.

TRACe<n>:DIRectory?

Sending this query returns a string containing the names, sizes and limits of all defined traces. The format of the response is as shown below:

name1,size1, start1, stop1;name2,size2, start2,
stop2; ... , stopn

TRACe<n>:FREE?

Sending this query returns the number of trace memory points in use and the number of trace memory points available. The format of the response is as follows:

<points_available>,<points_in_use>

TRACe<n>:FREE:LCONTiguous?

Sending this query returns the largest contiguous free memory space. That is the largest waveform size which can be defined. This can never be larger than 131072.

<numeric value>

TRACe<n>:SElect <trace name>

Sending this program message selects one of the defined traces stored in memory.

TRIGger<n>

TRIGger<n>

:COUNT <numeric_value>

:GATE

[:STATE] <Boolean>

[:IMMediate]

:POLarity <POSitive | NEGative>

:SOURce

[:START] <INTernal | BUS | EXTernal | MASTER |
INPut0 | INPut1 | INPut2>

:ADVance <INTernal | BUS | EXTernal | MASTER |
INPut0 | INPut1 | INPut2>

:TIMer <numeric_value>

TRIGger<n>:COUNT <numeric_value> (1)

This program message sets the number of times to cycle through a trace after a trigger is received. The COUNT value ranges from 1 to 1,048,575 for waveforms and 1 to 524,288 for sequences.

TRIGger<n>:GATE[:STATE] <ON | OFF>

This program message selects a gated mode of operation.

TRIGger<n>[:IMMediate]

This program message immediately triggers the instrument, independently of which trigger source was selected.

TRIGger<n>:POLarity <POSitive | NEGative>

This program message selects the active trigger level.

TRIGger<n>:SOURce[:START] <INTernal | BUS | EXTernal |
MASTER | INPut0 | INPut1 | INPut 2>

Sending this program message selects the source of the start trigger signal. The start trigger signal initiates activity when the instrument is in a triggered mode of operation.

- **BUS** Selects the interface dependent trigger signal such as GET for an IEEE 488.1 interface or Trigger for a VXibus Message Based Device interface. The IEEE 488.2 *TRG common program message also satisfies the requirement for this trigger source.
- **EXTernal** Selects an external signal jack as the trigger source.
- **INTernal** Selects an instrument dependent internal signal as the trigger source.
- **MASTer** Selects the MASTER trigger signal from the backplane.
- **INPut0** For Channel 1 this selects the trigger output of Channel 2. For all other channels this selects the trigger output from the previous channel.
- **INPut1** For Channel 1 this selects the trigger output of Channel 3.
- **INPut2** For Channel 1 this selects the trigger output of Channel 4 (do not use with Option 007).

TRIGger<n>:SOURce:ADVance <INTernal | BUS | EXTernal | MASTer | INPut0 | INPut1 | INPut 2>

Sending this program message selects the source of the advance trigger signal. The advance trigger signal initiates activity when the instrument is in a triggered mode of operation. The source selection definitions are the same as for the start trigger.

TRIGger<n>:TIMer <numeric_value> (1e-3)

Sending this program message sets the period of an internal periodic signal source. The timer signal acts as a trigger when it is the selected trigger source. It ranges from 2e-7 to 1e4 seconds with 2e-7 resolution.

DISPLAY

DISPlay

:TEXT <string>

:CLEar

:UPDate

DISPlay:TEXT <string>

This command allows you to send a message to the model 295 display to provide information or an operator prompt. The message contained in the <string> characters is displayed in a dialog box. The message may be multi-line; you select line breaks with the backslash (\) character. The message can have a maximum of 7 lines of 36 characters each. Excess lines and characters on a line are discarded. Characters can be any standard ASCII value from "32" (space) to "125" (j). The message dialog remains on the display until cleared with the DISPlay:TEXT:CLEar message. If a new TEXT command is sent while a previous one is still being displayed, the original TEXT box is automatically removed before the new one is displayed.

DISPlay:TEXT:CLEar

This command removes the message dialog box created by the DISPlay:TEXT <string> command.

DISPlay:UPDate

This command causes the model 295 front panel display to be redrawn,

using the last current set of commands executed to determine which information should be displayed. Under normal remote operation, the display is not updated when the remote interface is "busy", and it may lag behind the current instrument setup.

HVOLTAGE<N>

```
HVOLTage<n>
  :OUTPut
    [:STATe] <Boolean>
  :CINPut
    [:STATe] <Boolean>
  :SUM <Boolean>,<Boolean>,<Boolean>
  [:LEVel]
    [:IMMediate]
      [:AMPLitude] <numeric_value>
  :RESet
  :VERSion?
```

HVOLTage<n>:OUTPut[:STATe] <ON | 1 | OFF | 0>

If the High Voltage Option - 007 is installed in Channel 4 of the 295 (see Appendix G), this command turns on the High Voltage Output corresponding to standard ARB Channel <n>. If the Option is not installed, an error message is generated. The value <n> ranges from "1" to "3", with a default of "1" if no numeric suffix is given. This value selects and enables output "A" if <n> equals "1", "B" if <n> equals "2", and "C" if <n> equals "3". The normal summing path will put the output of ARB Channel 1 on High Voltage OUT A (and "2" to "B" and "3" to "C") when these input paths are enabled with the HVOLTage<n>:CINPut[:STATe] command. However, the inputs are also a matrix including the other ARB Channels and an external summing input, so it is not a simple one-for-one mapping (see Appendix G for more information).

HVOLTage<n>:CINPut[:STATe] <ON | 1 | OFF | 0>

If the High Voltage Option - 007 is installed in Channel 4 of the 295 (see Appendix G), this command enables the High Voltage Input corresponding to standard ARB Channel <n>. If the Option is not installed, an error message is generated. The value <n> ranges from "1" to "3", with a default of "1" if no numeric suffix is given. This value enables the output of ARB Channel 1 to pass to High Voltage input "A" if <n> equals "1", Channel 2 to "B" if <n> equals "2", and Channel 3 to "C" if <n> equals "3". This is the normal one-for-one mapping of ARB Channels through the High Voltage outputs. A more complex summing arrangement may be defined using the following HVOLTage<n>:SUM command.

HVOLTage<n>:SUM <ON|1|OFF|0>,<ON|1| OFF|0>,<ON|1|OFF|0>

This command may be used in addition to the two previous command to sum other sources along with the one-for-one mapping of ARB Channels to High Voltage outputs. Each High Voltage section, A through C, has a matrix of inputs available. The "normal" selection is the straight-through mapping of ARB Channel to High Voltage output, and that selection provides

controllable pre-attenuation and amplification (using the following command) to set the output to a known amplitude level. However, the other two ARB channels (if enabled by HVOLTage<n>:CINPut) and the external sum input also appear in the input matrix and may be selected to be summed into the output. This command selects which inputs in the matrix are selected. The first ON/OFF selection controls the state of the external summing input, the second the lower Channel number of the two "alternate" ARB Channels, and the third the higher Channel number. Each time an ARB Channel is used in a High Voltage output, either "straight-through" or "summed in", its contribution to the output signal is equal to the amplitude level set for it in the following command. When an external sum in signal is selected to appear in a High Voltage output, its contribution to the composite signal is determined by a fixed gain of 10.

```
HVOLTage<n>[:LEVel][:IMMediate][:AMPLitude]
                                     <numeric_value> (10)
```

Any ARB Channel input, Channel 1 through 3, enabled by the HVOLTage<n>:CINPut command is a summing term in all three High Voltage sections. The amplitude level of a given CHAN1 through CHAN3 term is set by this command. The amplitude level is programmable from 10 Vp-p to 80 Vp-p into $\geq 500\Omega$. When summing signals, the sum of all selected signal amplitudes should not exceed 80 Vp-p.

```
HVOLTage<n>:RESet
```

Sending this command resets all high voltage channels on the high voltage module to its power-on or default state (10 Vp-p output level, summing off, inputs disconnected, and all outputs off).

```
HVOLTage<n>:VERSion?
```

Sending this query returns a string containing the identification, version, and checksum of the high voltage ROM.

STATUS

```
STATus
```

```
  :OPERation
    :CONDition?
    :ENABle <NRf>
    [:EVENT]?
  :PRESet
  :QUESTionable
    :CONDition?
    :ENABle <NRf>
    [:EVENT]?
```

```
STATus:OPERation:CONDition?
```

Returns the contents of the Operation Condition Register. The Model 295 supports this query, but will only return the value "0", indicating operational condition.

```
STATus:OPERation:ENABle <NRf>
```

Sets the enable mask of the Operation Event Register, which allows true conditions to be reported in the summary bit. The Model 295 supports the

command by saving the mask value and by not generating an error, although the Status registers do not exist.

The <NRf> notation indicates that SCPI's <numeric_value> format is not used in this case. Refer to the IEEE488.2 <DECIMAL NUMERIC PROGRAM DATA>, flexible Numeric Representation for more information.

The "STATus:OPERation:ENABle?" query returns the enable mask of the Operation Event Register. The Model 295 returns the value sent previously with the command above using the <NR1> format.

STATus:OPERation[:EVENT?]

Returns the contents of the Operation Event Register. The Model 295 supports this query, but will only return the value "0", indicating operational condition.

STATus:PRESet

Sets the enable registers to all 1s. The Model 295 accepts the command without performing any action.

STATus:QUESTionable:CONDition?

Returns the contents of the Questionable Condition Register. The Model 295 supports this query, but will only return the value "0", indicating operational condition.

STATus:QUESTionable:ENABle <NRf>

Sets the enable mask of the Questionable Event Register, which allows true conditions to be reported in the summary bit. The Model 295 supports the command by saving the mask value and by not generating an error, although the Status registers do not exist.

The <NRf> notation indicates that SCPI's <numeric_value> format is not used in this case. Refer to the IEEE488.2 <DECIMAL NUMERIC PROGRAM DATA>, flexible Numeric Representation for more information.

The "STATus:QUESTionable:ENABle?" query returns the enable mask of the Questionable Event Register. The Model 295 returns the value sent previously with the command above using the <NR1> format.

STATus:QUESTionable[:EVENT?]

Returns the contents of the Questionable Event Register. The Model 295 supports this query, but will only return the value "0", indicating operational condition.

IEEE 488.2 COMMON COMMANDS

*CAL? Causes an auto calibration to be performed and returns a value of 0 if the calibration was successful. A non-zero response value indicates the calibration failed.



*CAL? Response Format

*CLSThe Clear Status command clears status data structures and forces the device to the Operation Complete Keyword Idle state.

*ESE <value> The Standard Events Status Enable command sets the Standard Events Register bit. The numeric value is entered as a decimal

value between 0 and 255.

*ESE? The Standard Events Status Enable Status query allows you to read the current contents of the Standard Event Status Enable Register. The device returns a value between 0 and 255.

*ESR? The Standard Event Status Register query allows you to read the current contents of the Standard Event Status Register. Reading this register clears it.

*IDN? The Identification query returns the following information: Manufacturer, Model, Serial number, and Firmware level.

*OPC The Operation Complete command causes the device to generate the operation complete message in the Standard Event Status Register when all pending select device operations have been finished.

*OPC? The Operation Complete query places an ASCII character 1 into the device's Output Queue after finishing all pending selected device operations.

*RCL<value> The Recall command causes the instrument setup state to go to the setup last stored with *SAV <value> or with MMEM:STOR:SET <value>, where <value> is the Stored Setting number from 0 to 32,767. The file name used is "Snnnnn", where "nnnnn" is the 5-digit string corresponding to <value>.

*RST Places the instrument in its power-on-reset state. All outputs are turned off and all parameters are returned to their default values. This command does not affect the TRACe sub-system.

*SAV The Save command stores the current instrument setup state as a Stored Setting, where <value> is the Stored Setting number from 0 to 32,767. This setup can be restored to the instrument with the *RCL <value> or with MMEM:LOAD:SET <"Snnnnn">. The file name created is "Snnnnn", where "nnnnn" is the 5-digit string corresponding to <value>.

*SRE <value> The Service Request Enable command sets the Service Request Enable Register bits. The numeric value is entered as a decimal value between 0 and 255. The integer value is expressed in base 2 (binary). Bit 6 indicates an enabled condition.

*SRE? The Service Request Enable query allows you to read the current contents of the Service Request Enable Register. The device returns a value between 0 and 63 or 128 and 191.

*STB? The Read Status Byte query allows you to read the status byte and Master Summary Status bit. The device returns a numeric value between 0 and 255.

*TRG If the instrument is in a TRIGgered mode of operation and the trigger source is set to BUS, this will initiate the triggered operation.

*TST? Causes a device specific self test to be performed and returns a 16-bit integer value as a response. The value of the response is 0 if the test passed. A non-zero response value indicates the test failed. The format of the response is shown below:

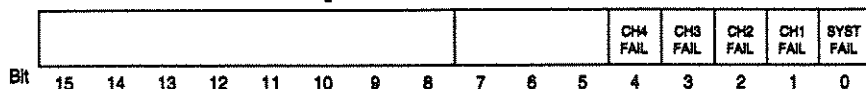

*TST? Response Format

The response contains a bit weighted error code that indicates on which boards failures were detected. A more detailed failure code is returned by the TEST<n>[:ALL]? query described above.

*WAIThe Wait-to-Continue command prevents the device from executing any further commands or queries until the No-Operation-Pending flag is TRUE.

HIGH SPEED BINARY WAVEFORM TRANSFER

The model 295 SCPI command TRACe<n>[:DATA] <trace_name>, <block> is used to download user-defined Waveforms from the remote controller to the ARB. Likewise, the query form TRACe<n>[:DATA]? <trace_name> is used to upload the waveform data back up to the controller. In both of these cases, the data block is transferred using the IEEE-488.2 Definite Length Arbitrary Block Data format (see the figure below). This format for block data transfer makes it possible to rapidly move the large amount of data required for arbitrary waveforms.

Definite Length Arbitrary Block Data Format

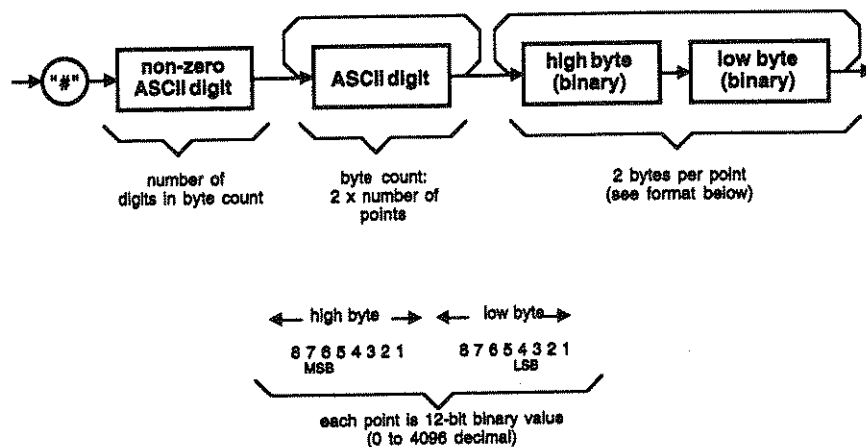

To send a block of waveform data, send an ASCII "#" (\$23), then an ASCII encoded digit whose value signifies the number of digits in the byte count, then ASCII encoded digit(s) representing the byte count, then the two byte binary data words (MSB first). The byte count is twice the number of points to be downloaded to the trace. The byte count must exactly correspond to the number of bytes in the block of data. Each data word is a two byte word representing a 12-bit binary unsigned integer between 0 and 4095.

Prior to downloading a Waveform using the TRACe<n>[:DATA] <trace_name>, <block> command, the Trace must be first reserved in the channel memory. Send the TRACe<n>:DEFine <trace_name>, <value> command to reserve trace memory of <value> points under the <trace_name>. This also presets the Trace Limits for this trace at full size. You may select a segment of this trace for download (or subsequently, for upload) using the TRACe<n>:LIMits <trace_name>, <start_index>, <stop_index> command.

When the block size exceeds the capability of your download/upload application, you may use the TRACe:LIMits feature to break the block up into manageable segments.

The "binary" transfer using this format occurs at a relatively high speed because the binary data is not parsed through the 295's Command Processor. Instead, the binary data is routed directly to the channel RAM without processing or limit checking, much like a direct memory access (DMA). If the waveform limits (size), the byte count or the number of bytes in the <block> are not all in numeric agreement, or one half second elapses without receiving any data, the high speed transfer will be aborted. Any data received after this will be interpreted by the Command Processor as ASCII characters and may cause the Model 295 to act unpredictably. Because of this low tolerance for errors, the high speed waveform transfer method should be used with extreme care.

NOTE

The High Speed Binary Waveform Transfer operates with the GPIB interface. Do not attempt a <block> transfer using the TRACe<n>[:DATA] commands when using the RS-232-C interface. This will also result in unpredictable behavior from the model 295.

RS-232-C PROGRAMMING

Baud Rate Setting

Section 2 describes the model 295 installation and interconnections for RS-232-C. Be sure that you have the baud rate set correctly at the 295 and at the DTE.

General RS-232-C Information

EIA standard RS-232-C specifies the electrical characteristics and pin out of a serial communication standard for connecting "data terminal equipment" (DTE) to "data communication equipment" (DCE). Data terminal equipment is usually devices such as terminals, computers, or printers that are the final destination for data. Data communication equipment, on the other hand, is usually a modem or other device that converts the data to another form and passes it through. Because RS-232-C signal lines defined as inputs on a DCE device are outputs on a DTE device and vice versa, connection of a DCE to another DCE or of a DTE to another DTE will require a special cable with many of the signals interchanged. These cables are often called "modem eliminators" because they are used to eliminate a pair of modems between two computers. The Model 295 can be configured only as a DCE, so in most cases it can be connected with a straight-through cable to a computer, but would require special cabling to connect to another DCE device.

The baud rate is the bit rate during the transmission of a word in bits per second. Different devices use many baud rates, but the baud rates of the two devices that are connected must be the same. The Model 295 can be set to 10 different baud rates ranging from 50 to 38,400 as described in Section 4, Utilities screen.

Data signals over the RS-232-C use a voltage of +3 to +25 V to represent a zero (also called a space) and a voltage of -3 to -25V to represent a one (also called a mark). Handshake and control lines use +3 to +25V to indicate a true condition and -3 to -25V to indicate a false condition.

When no data is being transmitted, the idle state of the data lines will be the mark state. To transmit a byte, the transmitting device first sends a start bit which is a space for one bit time (1 / baud rate) to synchronize the receiver. Next, the data bits are sent LSB first (the Model 295 uses 8 data bits), then at least one bit time of the mark state (stop bits) before initiating the transmission of the next byte. Some devices use an optional parity bit between the data bits and the stop bits. The Model 295 does not support this and it should be suppressed on the connected device (see the following figure).

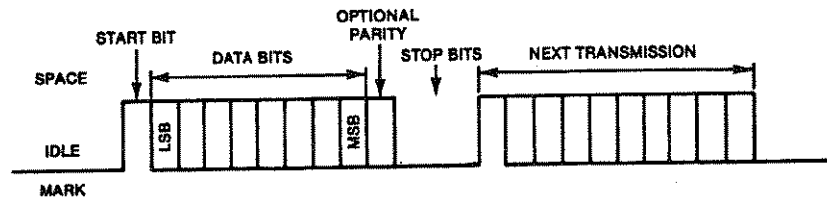

RS-232-C Transmission Example

The RS-232-C standard is not very specific about many of the handshaking signals and it is therefore usually necessary to refer to the manuals for both of the devices being connected to determine the exact pin out, signal definition, and signal direction for the devices (see Table 2-1 for the Model 295 pin outs).

Handshaking is used so that each device can tell the other device when it is ready or not ready to receive data. The Model 295 supports XON/ XOFF handshaking (see Table 5-2) but not CTS/DTR (hardware handshaking). With hardware handshaking, the DCE device pulls the CTS line positive or negative to indicate whether it is ready or not ready respectively and the DTE device pulls the DTR line positive or negative to indicate whether it is ready or not ready respectively. With XON/XOFF handshaking either device sends an XOFF (\$13) over the appropriate data line when it is no longer ready to receive data, then sends an XON (\$11) when it is again ready. When the Model 295 receives an XOFF character it will send a maximum of 3 characters before it stops transmitting and waits to receive an XON character.

When the Model 295's internal buffer fills, it will send an XOFF character over the data line. When it is again ready to receive data it will send an XON. After the Model 295 sends the XOFF, the connected device must stop sending data within 10 characters or data will be lost.

The serial interface implements the same SCPI command set as the GPIB interface, with the exception that the Definite Length Arbitrary Block Data format (see the previous major heading 'High Speed Binary Waveform Transfer'). Therefore, do not attempt sending the TRACe<n>[:DATA] commands when using the RS-232-C interface.

When the instrument is in the remote mode (sending the character '!' causes the instrument to go to remote), the RS-232-C interface input has priority over any front panel control. Therefore, as long as the serial interface is continuously supplied with data, the keyboard will appear to be inoperative to the user.

The Model 295 is programmed by sending ASCII coded characters to the instrument (see table 5-1 and Appendix C). Additionally, the RS-232-C responds to special Interface Control Characters. These are the characters '!', '\$', '?', 'XON', and 'XOFF' (see Table 5-2).

RS-232-C Terminator Characters

Upon "power-on", the Model 295 accepts either a carriage return (CR) or a line feed (LF) as an end of string (EOS) terminator and sends both a CR and LF as the EOS terminator. If the connected device does not recognize either one, the terminator will need to be changed. The terminator can be changed to any ASCII character other than XON and XOFF, or NULL by blah-blah-blah followed by the decimal ASCII code for the character.

Sending Waveforms over the RS-232-C Interface

Waveforms are sent to the Model 295 using the RS-232-C interface using the TRACe<n>:DATA:POINt or TRACe<n>[:DATA]:LINE command. The high speed <block> transfer used with the TRACe<n>[:DATA] <trace_name>, <block> command is used with the GPIB and not the RS-232-C interface.

Reading Waveforms over the RS-232-C Interface

Waveforms are read from the Model 295 using the RS-232-C interface using the TRACe<n>:DATA:POINt? query. The high speed <block> transfer used with the TRACe<n>[:DATA]? <trace_name> command is used with the GPIB and not the RS-232-C interface.

Table 5-2. RS-232-C Interface Control Commands

Character	ASCII	Function
!	\$21	Causes the Model 295 to go into remote mode. In remote mode the instrument setup can only be changed from the RS-232-C interface and not from the front panel. The front panel keys will still be active and can be used to query the instrument setup conditions. The instrument can be returned back to local mode by sending a '\$' over the interface or pressing the LOCAL soft key (unless it locked out by '*', see below).
\$	\$24	Causes the Model 295 to go to local mode. In local mode the instrument setup can be changed only from the front panel and will ignore any commands from the interface (except '!').
*	\$2A	Causes the Model 295 to disable the LOCAL soft key. After this, the only way the instrument can return to local mode is with a '\$' character from the interface.
?	\$3F	Causes the Model 295 to send the talk message as set by the talk mode to the connected device.
XOFF	\$13	Causes the Model 295 to stop transmitting data to the connected device (see handshaking above).
XON	\$11	Cancels the XOFF condition allowing the Model 295 to continue transmitting.

GPIB ERROR HANDLING AND STATUS REPORTING

Errors and status in the 295 are handled as described for Device Status Reporting consistent with the IEEE-488.2 standard in Chapter 11. Errors

and status may be monitored by reading the IEEE-488.1 Status Register, either by serial polling the 295 or by sending a Status Byte read command (*STB?) to the 295. Each module has its own Status Byte associated with its own secondary address. The serial poll or the *STB? query have to be done to the module's primary and secondary address.

Three bits in the Status Byte are defined as follows:

- **Bit 6 (DI07): RQS/MSS**

RQS/MSS acts as a summary bit for the rest of the Status Byte bits. If any of the other Status Byte bits are asserted along with their corresponding mask bits in the Service Request Enable Register, then the RQS/MSS bit will be asserted. This allows the controller to test for the RQS/MSS bit for selected information (selected by the mask bits in the Service Request Enable Register) automatically without having to mask and test the Status Byte manually.

RQS is in response to a serial poll and is partially defined in the IEEE-488.1 spec. and further defined in the IEEE-488.2 spec. RQS will be true during a serial poll if the 295 has an SRQ true condition pending.

MSS is in response to a *STB? query and is defined in the IEEE-488.2 spec. MSS will be true if the logical AND of the Status Byte bits and a mask byte, the Service Request Enable Register yields a true result in any bit location (except bit 6 of course). The only bits used in the 295 are bit 4 (DI05) and bit 5 (DI06) mentioned below.

- **Bit 5 (DI06): ESB**

Standard Event Status Bit Summary Message. This is a summary message bit for the Standard Event Status Register, q.v. next section.

- **Bit 4 (DI05): MAV**

Message Available Queue Summary Bit. This bit is always true if another byte is available to be output to the controller. When the queue is empty, the MAV bit is cleared.

The remaining bits in the 295 Status Byte have no effect. The ESB bit is a summary bit for another status register, called the Standard Event Status register, which is used to extend the types of status information available to the controller from the instrument's status functions. The IEEE-488-2 document defines all eight bits for particular functions. The 295 only uses a subset of these. They are as follows:

- **Bit 7: Power On** (not used)
- **Bit 6: User Request** (not used)
- **Bit 5: Command Error**

Set to true whenever a syntax error is encountered in the command string to the 295.

- **Bit 4: Execution Error**

Set whenever a parameter exceeds the range available for that parameter, except for inter-parameter conflict errors which are handled by bit 3.

- **Bit 3: Device Dependent Error**

Set whenever the instrument module encounters an error specifically associated with the operation of that type of module. This includes inter-parameter conflict errors.

- **Bit 2: Query Error**

Set whenever a query is made to the 295 for which no response is available.

- **Bit 1: Request Control (not used)**

- **Bit 0: Operation Complete**

Set whenever the last command has finished execution and the 295 is ready to accept another command or the results from the last query are available.

This register, along with a mask enable register called the Standard Event Status Enable Register, is used to set the ESB bit in the Status Byte of the 295 GPIB inter-face. The Standard Event Status Register (ESR) is bit-wise logically ANDed with the Standard Event Status Enable Register (ESE) to generate the ESB bit. If any of the bits in the ESR are true along with the corresponding bits in the mask ESE, then the Event Status Summary Bit (ESB, bit 6) in the GPIB Status Byte will be asserted. This way the Status Byte can be serial polled to see if any one of the conditions in the ESR has occurred.

Below is a list of the possible error messages that might occur during operation. Each is listed inside quotes with explanation of what it means.

1. "amplitude + offset out of range"

Peak amplitude added to offset value exceeds maximum limit of output amplifier (+/- 10v peak).

2. "no auto-filter for selected function"

Auto filter only allowed in sine for function generator.

3. " *** <parameter >: limit error ***"

This error message will happen any time the value sent exceeds Timing Generator maximum limits. *Parameter* is any of the parameters that takes a value with it. (Amplitude being set for 25v will result in " *** amplitude: limit error ***")

4. " *** illegal function for duty cycle ***"

Duty cycle only allowed in square and ramp functions.

5. " *** frequency for function out of range ***"

Maximum frequency varies depending on which function is selected (see specifications).

6. "no duty at high frequency"

Duty cycle not allowed above 1Mhz frequency.

7. "could not allocate system memory"

"could not free memory"

"could not free system memory"

"error in allot system memory"

"can not allot system memory for download"

When download or Autocal is done, the processor will allocate dynamic memory for temporary storage of the data. It frees this space after completion. This error should not happen under normal conditions.

8. "recall database error"

"recall checksum error"

When doing Autocal or selftest, the Arb Generator will store current settings before starting and then recall them after completion. If the checksum fails during recall, this error will result. The same message applies to normal stored settings. This error should not occur during normal operation.

9. "cal data base corrupted, re-Autocal"

Attempt to enable Autocal database was made and checksum or status bit information was garbage. Arb needs Autocal run to correct problem.

10. "vectoring not possible, bad address"

The last two addresses selected were invalid. The second was before the first or they both have not been selected.

11. "xmin greater than xmax"

Xmin is start address of copy block and xmax is ending address of copy block, therefore xmin has to be less than xmax.

12. "xmax - xmin + 1 less than 8 points"

Minimum size of copy block is 8 points (minimum waveform size).

13. "xmax outside waveform space!!"

Xmax is set to an address value that is beyond last address of selected waveform.

14. "too many points sent in download"

The number of points sent in download exceeded the size of selected waveform.

15. "download failed!!"

The waveform number and size have not been selected prior to download.

16. "insufficient memory to allocate"

This message will occur when copy needs more space for block than is available due to already allocated space. Maximum space is 12288 total.

17. "overflow address error"

"overflow address error, try again"

If selected address is outside waveform space of current waveform, one of these errors will occur.

18. "waveform size not set, can't edit"

If address executed when a waveform is not selected, this message will occur.

19. "size already exists for waveform"

Once size has been defined for a waveform, you cannot redefine it. To change the size, you have to delete the waveform and re-select it with

the new size desired.

20. "stop in another waveform space"

Stop point is not within currently selected waveform space.

21. "waveform less than 8 points"

Stop - start + 1 is less than minimum waveform size.

22. "no frequency change in raster mode"

While in raster mode, you can only change frequency by changing raster freq value or start and stop points. Actual frequency of output is equal to raster freq divided by length of selected waveform.

23. "waveform does not have size"

This error message is caused by trying to normalize waveform when there is no size to do it on.

24. "no quick cal for module"

Quick cal is not implemented on Arb module.

RESUMING LOCAL OPERATION

When the GPIB or RS-232-C interface has remote control of the Model 295, your front panel operator controls will function only to query, and not set, parameter values (even then, only when there is no bus activity). When you discontinue remote interface operations, you will not have local control returned to you unless the remote application has specifically sent a Go To Local (IEEE-488.1 ASCII GTL) code. If you find that you do not have local control after a remote programming session, you will have to manually return to local control. To do this, select the Utilities:Remote screen. Select the "Currently" box and toggle it from REMOTE to LOCAL. This will restore normal local operations. However, if the "Currently" box shows LOCAL LOCKOUT, you will have to send the remote command Device Clear or Selected Device Clear to clear the LLO and return to local. This could also be accomplished by cycling power to the Model 295.

1
2
3
4
5
6
7
8
9
10
11
12
13
14
15
16
17
18
19
20
21
22
23
24
25
26
27
28
29
30
31
32
33
34
35
36
37
38
39
40
41
42
43
44
45
46
47
48
49
50
51
52
53
54
55
56
57
58
59
60
61
62
63
64
65
66
67
68
69
70
71
72
73
74
75
76
77
78
79
80
81
82
83
84
85
86
87
88
89
90
91
92
93
94
95
96
97
98
99
100

A.1 THE MODEL 295

The Model 295 is a high performance Synthesized Arbitrary Waveform Generator (ARB) with the following main features:

- Up to 4 Independent Arb Channels
- Up to 50 MHz Sampling Frequency with ± 2 ppm Accuracy
- 12 Bit Vertical Resolution with up to 15 Vp-p Output
- A Graphical Interface Simplifies Instrument Setup
- 32K points (128K or 512K optional) Horizontal Resolution
- Waveform Linking, Looping and Sequencing
- Interchannel Triggering, Summing and Phase Control
- 80 Vp-p Optional High Voltage Outputs
- Optional Floppy Disk Drive for DSO Waveform Upload and Waveform Data Transfer and Storage
- IEEE-488.2 (SCPI) Compatible Command Language

The Model 295 Synthesized Arbitrary Waveform Generator (Arb) allows you to generate both standard and user defined (arbitrary) waveforms. It has a repertoire of standard waveforms, a drawing capability, an equation parser, and a versatile editor. With the editor, you can modify and/or combine existing waveforms. Waveforms can also be looped to provide repetitious or continuous output, and they can be linked to form sequences.

Featured are flat panel graphics display with "pop-up" windows and waveform editing augmented with a mouse. The instrument uses an internal 50 MHz clock reference frequency to provide standard, built-in waveform outputs. The frequency range for all standard waveforms is 1 μ Hz to at least 2MHz; the upper range of sine and square extends to 20 MHz and 25 MHz respectively. A TTL clock signal usable to 100 MHz is available on the Clock Out BNC. An optional 3.5 inch disk drive enhances waveform storage.

Arbitrary waveforms use a synthesized sample clock ranging from 125 mHz to 50 MHz, with 5 digits of resolution. The waveform resolution is 5 points to 32K points (optionally 128K or 512K points) horizontally and 12 bits vertically.

The basic instrument includes a mouse and contains a single Arb Channel module. Waveform storage of the single channel unit is in battery backed RAM on the internal Processor assembly. Up to three additional Arb Channel modules can be added along with the optional disk drive. For Adequate waveform storage in multi-channel systems, the disk drive is recommended. The disk drive provides additional advantages, such as loading waveforms generated on a PC using Wavetek's WaveForm DSP™ software or "spread-sheet" applications.

The main waveform output provides up to 15 Vp-p into 50Ω (30 Vp-p, open circuit). Waveform dc offset or dc output is also provided up to ±7.5V into 50Ω (±15V into open circuit). A signal programmed at a channel output may be sent to the backplane summing bus, or signal present at the summing bus may be summed into a channel output. In parallel operation, Model 295 channels may be slaved to a master clock/trigger bus on the chassis backplane to create a multichannel waveform synthesizer with phase control between channels.

A High Voltage Option channel card provides channel summing with outputs up to 80 Vp-p.

The control language adheres to the SCPI (Standard Commands for Programmable Instruments) format Version 1992.0, February 1992 (refer to the SCPI manual for further information). SCPI is an industry standard language for remote instrument programming.

The Model 295 has extensive self-adjustment utilities built in. Calibration constants are maintained in non-volatile memory.

A.2 SPECIFICATIONS

Performance specifications apply within the specified environmental conditions after a 20 minute warm up period. Specifications are subject to change without notice.

A.2.1 Standard Waveforms (Functions)

Sinusoid	Square	Triangle
Pseudo-Random (noise)	Positive Ramp	Negative Ramp
Pos Haversine	Neg Haversine	Sinc (Sin(x)/x)
Wtst**	DC	

In addition, Model 295 generates arbitrary (or user defined) waveforms. Paragraph A.2.2 describes the Arbitrary waveform generator's characteristics.

***The "Wtst" waveform is not one of the Standard waveforms available for use. It is an "internal" waveform reserved for diagnostics. Attempting to use the "Wtst" waveform or to use "Wtst" in the name for an arbitrary waveform will generate an error message.*

A.2.2 User-Defined (Arbitrary) Waveform Creation and Editing

The user can create arbitrary waveforms of any size limited only by the available channel memory. User defined waveforms may be created via front panel editing controls (keyboard and mouse), or downloaded through GPIB interface, optional floppy disk, or optional direct DSO download.

Front panel waveform creation and editing is accomplished using the mouse and/or front panel keys assisted by Z-Axis modulation of an external oscilloscope.

Resolution

Horizontal Resolution:	32K points, 128K, or 512K points optional (minimum waveform size 5 points).
Vertical Resolution:	12 bits

Arb Clock (Sample Frequency)

<i>Range:</i>	125.1 mHz to 50 MHz.
<i>Resolution:</i>	5 digits or 0.1 mHz.
<i>Accuracy:</i>	<±2 ppm over 0°C to +50°C using internal reference.

Waveform Editing

The Model 295 uses an oscilloscope to create or edit waveforms. The mouse in combination with Z-axis modulation creates a "drawing" environment on the oscilloscope's screen. After making three simple connections and the initial oscilloscope setup, horizontal and vertical scaling minimize the user's need to adjust the oscilloscope while editing.

Drawing Tools

The Model 295 provides the following tools for waveform editing. Some tools require selection of a "block" (from 5 waveform data points up to the size of the waveform) before using the tool.

Copy

Copies the selected block into the clipboard.

Delete

Deletes the selected block. The data value for each point in the block becomes zero.

Freehand Draw

Sketches waveforms directly on the oscilloscope. Does not require a block to be selected.

LineDraw

Draws lines between endpoints, selected using the mouse. Does not require a block to be selected.

Math

Replacing the block with a math expression. With the exceptions of Line and Block, the Model 295 normalizes the full-block "amplitude" between plus and minus one. The following expressions are supported:

Line(y1, y2)	Replaces the block with a line beginning at y1 and ending at y2.
Sine(t x n+p)	Replaces the block with n cycles of a Sine wave shifted by p, a fraction of the cycle.
Triangle(n, d)	Replaces the block with n cycles of a Triangle wave with duty cycle d in percent [0.01 to 99.99].
Pulse(n, d)	Replaces the block with n cycles of a Pulse with duty cycle d in percent [0.01 to 99.99].
Tangent(t x n+p)	Replaces the block with n cycles of a Tangent wave shifted by p, a fraction of the cycle. The Tangent is limited to plus or minus one between 87 and 93 degrees and between 267 and 273 degrees.
Exponential(t x n+p)	Replaces the block with n cycles of an Exponential wave shifted by p, a fraction of the cycle. A cycle begins with Exp(0) and ends at Exp(3). [1 to 20.09]

	The cycle is offset and scaled to lie between plus and minus one.
Log(t x n+p)	Replaces the block with n cycles of a Log base 10 wave shifted by p, a fraction of the cycle. A cycle begins with Log(0.1) and ends at Log(10). [-1 to +1]
Random	Replaces the block with a random function scaled between plus and minus one. Requires no arguments.
Block	The selected block becomes part of the math expression. Useful for scaling or adding another function into the selected block.

Insert

Inserts a copied block from the clipboard into a waveform. The operation does not erase the clipboard and additional pasting can be done as needed. Only a start point needs to be selected for insertion.

VertMov

Vertically offsets a block. Peak amplitude of the block cannot exceed plus or minus one.

VertRsz

Changes peak to peak amplitude including inverting amplitude.

Zoom

Magnifies a block to fill the entire oscilloscope screen. Zoom can be repeated as many times as needed. The limit for Zoom is an eight point block.

Unzoom

Returns a Zoomed block to its original trace size.

Line List

Line List provides a method to easily create trapezoidal (series of line segment) waveforms by entering a list of vertices directly from the front panel without using the waveform cursor on the oscilloscope (such as the Line Draw tool requires).

A.2.3 Operational Modes

CONTINUOUS:

The selected waveform is output continuously at the programmed frequency, amplitude and offset. The sync marker is output once per waveform (selectable as a pulse at the start of the waveform or as a zero-crossing output of the waveform) and, except for Standard waveforms, the position marker is output at any selected point(s) of the waveform.

Standard waveforms are synthesized using a 50 MHz sample rate, and the desired waveform frequency is set by adjusting the number of "points" in the waveform. Frequency resolution for the Sine, Square, and Haversines is 8 digits limited by 1 μ Hz, 5 digits for frequencies >20 MHz. Frequency Resolution for the Ramps, Triangle, and Sinc is 8 digits limited by 1 μ Hz, 5 digits for frequencies \geq 100 kHz. The appropriate filter is automatically selected. When a User-defined arbitrary waveform is selected, the sample frequency is set in the

range of 0.1251 Hz to 50 MHz with 5 digit resolution. The sample frequency is the desired waveform frequency multiplied by the number of points in the waveform. No Filter is selected. For details, see paragraph A.2.6, Frequency.

For remote (SCPI) programming, select Continuous mode by setting INITiate:CONTInuous ON and [SOURce:]FREQUency:MODE to CW or to FIXed. Then frequency is determined by the TRACe MODE (CW or RASTer), programmed FREQUency value (CW waveform frequency or RASTer sample clock frequency), and ROSCillator SOURce (INTernal, BUS, or EXTernal clock source). For SCPI details, see Section 5.

TRIGgered:

Waveform output is quiescent at first data point of selected trace until a triggering event (selectable by TRIGger SOURce), after which a single waveform at the programmed frequency, amplitude and offset is initiated. The waveform completes the number of cycles set by the TRIGger COUNT and returns to its quiescent baseline value for another triggering cycle. The triggering baseline is the level of the first waveform address. Frequency resolution is 5 digits and maximum frequency is 10 MHz for all waveforms. For details, see paragraph A.2.12, Triggering.

For remote (SCPI) programming, select Trigger mode by setting INITiate:CONTInuous OFF and TRIGger:GATE OFF. Set TRIGger:COUNT to the desired value of repeat cycles. For SCPI details, see Section 5.

GATE:

Same as Triggered except output is continuous for duration of gate signal. Last waveform cycle is always completed when gate signal is removed.

For remote (SCPI) programming, select GATE mode by setting INITiate:CONTInuous OFF and TRIGger:GATE ON. For SCPI details, see Section 5.

AM/SCM:

Operates as in Continuous Mode above, except that the output can be Amplitude Modulated or Suppressed Carrier Modulated by external signals. For details, see paragraph A.2.13, Modulation.

For remote (SCPI) programming, select AM/SCM mode by setting [SOURce:]AM ON and [SOURce:]AM:MODE to AM or to SCM.

SWEep:

Operates as in Continuous Mode above, except that the output frequency can be swept by an internal sweep generator between programmed start and stop frequencies.

Sweep capability is provided for Standard waveforms and Arbitrary waveforms with a length that is a multiple of 4096 points. A horizontal sweep output voltage is also provided. For details, see paragraph A.2.11, Sweep.

For remote (SCPI) programming, select Sweep mode by setting INITiate:CONTInuous ON and [SOURce:]FREQUency:MODE to SWEep. See Section 5 for the other Sweep mode settings.

SEQUENCE:

Linked Sequence mode provides linking, looping and advancing of multiple waveform segments. This allows the creation of waveform sequences. For details, see paragraph A.2.10, Linked Sequence Operation. For SCPI details, see Section 5.

CLOCK:

This is a special "mode" included to provide up to 100 MHz TTL signal from the Clock Out. When Clock mode is selected, the Main Out is turned off, and the Clock Out frequency is selectable from 0.1251 Hz to 100 MHz with 5 digit (limited by 0.1 mHz) resolution. For details, see paragraph A.2.15, Clocks.

For remote (SCPI) programming, select Clock "mode" by setting OUTPut:CLOCK:FREQuency to the desired value. For SCPI details, see Section 5.

A.2.4 Input and Output Specifications

A.2.4.1 System (Chassis) I/O Connectors

The Model 295 consists of a chassis and one to four ARB channel cards. The chassis supports System resources and I/O. System I/O consists of four BNC connectors and three interface connectors, all mounted on the rear panel.

System Trigger Input BNC (>1K Ω)

Allows an external trigger signal at System Trigger Input to trigger selected Arb Channels. System trigger allows selectable trigger slope (positive or negative) and adjustable threshold levels ($\pm 10V$ in 80 mV steps). Power on default is compatible with positive-going TTL signals. Accuracy of the level setting is $\pm 0.4V$. Minimum trigger level and width required is 1.0 Vp-p and 30 nanoseconds. Maximum allowed input level is $\pm 15V$.

Reference Input/Output BNC (>1K Ω / 50 Ω)

Programmable as TTL level input or TTL level output. When configured as input, the 10 MHz system clock is accepted from an external source ($< \pm 10\%$ accuracy required, source rejected if $> \pm 20\%$). If no valid external signal exists, the internal reference is used. The default configuration is input. Maximum allowed input level is $\pm 15V$. When configured as an output, the internal 10 MHz reference clock is delivered to the output connector. The output is protected against short circuits to ground.

Z-Axis Output BNC (600 Ω)

A variable level pulse output used with waveform editing for intensity modulation of an oscilloscope display. Selectable peak level is 0 to +9.4V in 40 mV steps to interface with most common oscilloscopes. Accuracy of the output level is $\pm(10\% + 100\text{ mV})$ when terminated into $\geq 1M\Omega$. Pulse polarity inversion is selectable, pulsing from the positive level to zero volts. The output is protected against short circuits to ground and $\pm 15V$.

Horizontal Sweep Output BNC (2 k Ω)

A linear output ramp from 0 to +10 volts (open circuit) proportional to sweep position between selected start and stop limits is provided to drive the horizontal axis of an oscilloscope or chart recorder. Amplitude accuracy is $\pm 2\%$ when terminated into $\geq 1M\Omega$. The output impedance is 600Ω and is protected against short circuits to ground and $\pm 15V$.

EIA-RS-232 Interfaces

Two nine-pin serial ports on the instrument provide an interface with a two-button mouse and a remote terminal connection. Baud selection is one of 38.4K, 19.2K, 9600, 4800, 2400, 1200, 600, 300, 110, or 50. The mouse port default parameters are Microsoft™ serial mouse compatible and cannot be adjusted.

GPIB Interface

The IEEE-488.1 port address is selected under program control and stored in non-volatile RAM. The interface functions supported are: SH1, AH1, T2, L2, SR1, RL1, DC1, DT1, C1, C2, C3, C4, and C28.

A.2.4.2 ARB Channel I/O Connectors

The Model 295 chassis accepts up to four ARB channel modules. Each ARB Channel has six BNC I/O connectors which extend through the chassis' rear panel.

Main Output BNC (50 Ω)

Output of selected waveform, amplitude, offset, and mode. 30 Vp-p max. when unloaded. Source impedance is 50Ω . The output is protected against short circuits to ground and $\pm 15V$.

Channel Trigger Input BNC (>1K Ω)

TTL level trigger used to trigger waveform channel. Maximum allowable input is $\pm 15V$.

V_{IHmin}	2.1 V
V_{ILmax}	0.8V
minimum pulse width:	20 ns

AM Modulation Input BNC (10 k Ω)

Signal present at this input amplitude modulates the Main Output signal. Modulation bandwidth is DC to > 500 kHz. AM (amplitude modulation) and SCM (suppressed carrier modulation) are supported. Maximum allowable input is $\pm 15V$.

Clock Input/Output BNC (>1K Ω / 50 Ω)

Selectable as either TTL level clock input or TTL level clock output:

Configured as an input:

Clock input used as waveform sample clock can range from DC to 50 MHz. Maximum allowable input is $\pm 15V$.

Amplitude Range:	TTL levels; $V_{IHmin} = 2.1 V$, $V_{ILmax} = 0.8V$.
Min Pulse Width:	20 ns

Configured as an output:

TTL Clock output is 0.1251 Hz to 50 MHz waveform sample clock in normal operation and 0.1251 Hz to 100 MHz in Clock mode. The output is protected against short circuits to ground.

Resolution/Accuracy: Same as the frequency synthesizer.
Levels: Low level < 0.5V into 50Ω
High level > 2.1V into 50Ω
Rise and Fall time: <3 ns into 50Ω

Sync Marker Output BNC (50Ω)

TTL compatible pulse into 50Ω at the waveform frequency. Sync generation technique is selectable as "ZCROSS" or as "BBITs". Protected against short circuit to ground.

Levels: Low level < 0.5V into 50Ω
High level > 2.1V into 50Ω
Rise and Fall time: <7.5 ns into 50Ω

If ZCROSS is selected, the sync is generated from zero-cross detecting (independent of DC offset) the waveform. The sync marker is a TTL high whenever the waveform is positive. This is the default and preferred selection for Standard waveforms except haversines (when TRACe MODE is set to CW).

When BBITs is selected, the SYNC MARKER is a TTL high for a variable number of samples (minimum of two sample periods, see POSITION MARKER description for explanation) starting at the first waveform memory location used. This is the default for User-defined arbitrary waveforms (when TRACe MODE is RASTER). However, either sync technique is applicable depending upon the waveform characteristics.

Position Marker Output BNC (50Ω)

TTL compatible pulse into 50Ω. User programmable position markers for use with User-defined Waveforms. User can clear the markers low at all points or set the marker high at any point in a trace. Protected against short circuit to ground.

A marker set at address zero will be true during the trigger quiescent baseline. If address 1 is set (and zero is not), the POSITION MARKER output follows the trigger event plus the pipeline delay.

The Position Marker is one waveform data point (not necessarily 1 clock) wide for each location selected. In CW mode, for high frequency waveforms, a data point may not be accessed in each pass through the waveform. For very low frequencies each point may be sampled for a number of clock cycles.

Levels: Low level < 0.5V into 50Ω
High level > 2.1V into 50Ω
Rise and Fall time: <7.5 ns into 50Ω

A.2.4.2 Backplane (Intermodule) I/O

The Model 295 chassis contains a backplane with the connectors and signal interconnections for the ARB channels. Some of these interconnections serve to support operation of multiple channel cards in "series" or in

"parallel", where intermodule signal routing is handled automatically using the backplane. These signals consist of Triggers, Clocks, Phase information, and analog SUM BUS signals. For more information see paragraph A.2.14, Interchannel Operation.

A.2.5 Waveform Characteristics

Square Transition Time:

For $\leq 10V_{p-p}$:	<9.0 ns
For $> 10 V_{p-p}$:	<9.5 ns
Square Aberrations:	<(5% + 20 mV)

Square Symmetry: (0 °C to +50 °C)

< 10 MHz:	50 % \pm 1 %
\geq 10 MHz:	50 % \pm 2 %

Sine Distortion: (Maximum Harmonic level, Elliptic filter selected)

<100 kHz, $\leq 15 V_{p-p}$:	-60 dBc
<5 MHz, $\leq 10V_{p-p}$:	-45 dBc
<5 MHz, $\leq 10V_{p-p}$:	-40 dBc
≤ 20 MHz, $\leq 10V_{p-p}$:	-35 dBc
≤ 20 MHz, $\leq 10V_{p-p}$:	-28 dBc

Intermodulation Products: (Maximum Spur level, Elliptic filter selected)

<5 MHz:	- 60 dBc
<10 MHz:	- 50 dBc
≤ 20 MHz:	- 35 dBc

A.2.6 Frequency

Frequency Accuracy

$\leq \pm 2$ ppm over a range 0°C to +50°C temperature (Internal Reference)

Frequency, Standard Waveforms

Range:	1 μ Hz to 20 MHz (Sine and Haversines), 1 μ Hz to 25 MHz (Square), 1 μ Hz to 2 MHz (all others - 25 point wave- form minimum).
Resolution:	Sine, Square, and Haversines: 8 digits limited by 1 μ Hz, 5 digits for frequencies > 20 MHz. Ramps, Triangle, and Sinc: 8 digits limited by 1 μ Hz, 5 digits for frequencies ≥ 100 kHz.

Frequency, Arb Waveforms

Range:	0.1251 Hz to 50 MHz Sample Rate.
Resolution:	5 digits limited by 0.1 mHz, Minimum wave- form length - 5 Points.

Frequency, Clock Output

Range:	0.1251 Hz to 100 MHz.
Resolution:	5 digits.

A.2.6.1 Arb Clock and Waveform Timing:

CW (Phase Accumulate) Mode:

The waveform is generated by a phase accumulator. "Standard" waveforms occupy a fixed 4K block of points and are output in CW playback mode. When standard waveforms are selected in a triggered or gated mode of operation, the clock frequency resolution is reduced from eight to five digits.

Raster Mode:

User defined (arbitrary) waveforms are generated by scanning through each point in the trace, one clock cycle per point. User waveforms can have horizontal resolution ranging from 5 points to 32K (128K optional) points. The internal raster clock frequency is programmable from 125mHz to 50 MHz with 5 digits resolution, limited by 0.1 mHz. Waveform frequency is calculated by dividing the clock frequency by the number of points in the trace.

A.2.7 Amplitude

Range: 0.015 to 15 Vp-p into 50 Ω ,
0.03 to 30 Vp-p into >10 k Ω .

Resolution: 3.5 digits

Accuracy: Greater of $\pm 1\%$ of setting or Limit listed below.

Peak Amplitude +ABS(Offset)		Limit
>2.500V	to $\leq 7.500V$	± 15 mVp
>1.250V	to $\leq 2.500V$	± 7.5 mVp
>625 mV	to $\leq 1.250V$	± 3.75 mVp
>312.5 mV	to ≤ 625.0 mV	± 2 mVp
>156.3 mV	to ≤ 312.5 mV	± 1 mVp
>78.13 mV	to ≤ 156.3 mV	± 500 μ Vp
>39.06 mV	to ≤ 78.13 mV	± 250 μ Vp
	to ≤ 39.06 mV	± 125 μ Vp

Monotonicity: 0.2%

Flatness relative to 1 kHz: (Elliptic filter selected, non sweep modes).

	25°C \pm 10°C	0 to 50°C
Freq < 5 MHz	$\pm 2\%$	$\pm 5\%$
Freq \leq 20 MHz	$\pm 5\%$	$\pm 10\%$

A.2.8 Offset

Range: ± 7.5 V into 50 Ω ;
 ± 15 V into >10 k Ω .

Resolution: 3.5 digits

Accuracy: Greater of $\pm 1\%$ of setting or Limit listed below.

Peak Amplitude +Offset		Limit
>2.500V	to $\leq 7.500V$	± 15 mVdc
>1.250V	to $\leq 2.500V$	± 7.5 mVdc
>0.625V	to $\leq 1.250V$	± 3.75 mVdc
>312.5 mV	to ≤ 625.0 mV	± 2 mVdc
>156.3 mV	to ≤ 312.5 mV	± 1 mVdc
>78.13 mV	to ≤ 156.3 mV	± 500 μ Vdc
>39.06 mV	to ≤ 78.13 mV	± 250 μ Vdc
	to ≤ 39.06 mV	± 125 μ Vdc

A.2.9 Filtering

Three filtering selections:

20 MHz, 4 pole Bessel.

20 MHz, 7 pole, 6 zero Elliptic.

No filter.

A.2.10 Linked Sequence Operation

Linked Sequence mode provides the ability to link multiple arbitrary waveforms together into a long and complex waveform sequence. Each waveform becomes a waveform segment of the overall sequence. Each segment is assigned a unique loop count with a programmable advance event to the next segment in the sequence. The total number of data points in all waveform segments of an active sequence may not exceed the installed waveform memory size (see Horizontal Resolution in User-Defined Waveforms section). Additionally, two channels may be linked together via inter-channel triggering and summing to double the effective sequence length.

<i>Waveform Segments:</i>	2 to 4 per channel
<i>Segment Loop Count:</i>	1 to 65,535 or continuous
<i>Start Conditions:</i>	Immediate or selected start trigger event.
<i>Advance Conditions:</i>	Loop done OR Loop continuously until selected advance trigger event true OR Loop done <i>and</i> advance trigger true.
<i>Advance Trig Types:</i>	<i>Event</i> - Trigger must transition to the true state to qualify as an event. Trigger event is latched. <i>Level</i> - Trigger must be in the true state to initiate an advance. Trigger is not latched.
<i>Advance Types:</i>	<i>Synchronous</i> - Current segment is completed before next segment starts. <i>Asynchronous</i> - When advance conditions are met, next segment is started immediately. Current segment is not completed.
<i>Sequence Modes:</i>	Continuous or Triggered (1 to 524,287)

Notes

If advance condition from last segment to first segment is "advance trigger true" or "Loop done and advance trigger true", the sequence must be run in continuous mode.

The trace limits of each trace taken from each block in the sequence are determined by the trace selected by the TRACe:SElect command previous to selecting the SEquence Mode.

A.2.11 Sweep

The Model 295 allows you to sweep all standard waveforms and some user Waveforms with a length that is a multiple of 4096 points. Any or all channels with equal length waveforms may be swept with the same sweep time. The system also supplies a horizontal sweep output voltage.

<i>Sweep Type:</i>	"Sweep & Reset" or "Sweep & Reverse"
<i>Sweep Time:</i>	30 ms to 1000 s (12 steps at 30 ms)
<i>Sweep Spacing:</i>	Linear or Log
<i>Sweep Count:</i>	1 to 1,000,000
<i>Sweep trigger pulse width:</i>	500 μ s (min.)

Sweep Modes:

- Continuous Sweep & Reset:* Output frequency sweeps from start frequency to stop frequency, or stop to start if direction is down, with selected spacing (linear or log).
- Continuous Sweep & Reverse:* Output frequency sweeps from start frequency to stop frequency, then back to start frequency with selected spacing.
- Triggered Sweep & Reset:* Same as Continuous Sweep & Reset except output holds at start frequency (or stop if down selected) until receipt of trigger. Programmed number of sweeps, set by Sweep Count, are completed for each trigger signal.
- Triggered Sweep & Reverse:* Same as Continuous Sweep & Reverse except output holds at start frequency until receipt of trigger. Programmed number of sweeps are completed for each trigger signal.
- Triggered Sweep & Hold:* Same as Triggered Sweep & Reset except frequency is held at end of each sweep. An additional trigger is required to return to beginning of sweep.
- Triggered Sweep & Hold with Reverse:* Same as Triggered Sweep & Reverse except frequency is held at stop frequency. An additional trigger is required to initiate a sweep back to start frequency.

A.2.12 Triggering

The Model 295 supports a variety of trigger sources for non-continuous modes, linked sequences, and inter-channel coupling.

Trigger Sources

- 1) System Trigger, derived from:
 - a) System Trigger Connector,
 - b) Manual Trigger key, or
 - c) Remote interface trigger (*TRG or GET)
- 2) Channel Trigger Connector(s)
- 3) Channel Internal Trigger Rate Generator(s)
Period: 200 ns to 10,000s
resolution: 200 ns
- 4) Channel specific remote interface trigger (TRIGger<n>[:IMMediate])
For multiple channel systems:
- 5) Master Internal Trigger Generator - Derived from Channel 1 trigger rate generator.
- 6) Previous channel trigger out - derived from:
 - a) Trigger Count Complete.
 - b) Loop Complete from any or all segments (only valid for a linked sequence).
 - c) Waveform Complete from a User Waveform OR any or all segments of a linked sequence.

Triggering Destinations

- Start Trigger:* Initiates gated or triggered modes and starts linked sequences.

Advance Trigger: Conditions advances between segments of a linked sequence.

Trigger Delay (TTL Input)

During Standard Functions: <250 ns.
During User Waveforms: <400 ns.

Trigger Jitter (TTL Input)

During Standard Functions: <20 ns.
During User Waveforms: <40 ns.

Note

Trigger delays and jitter specified with internal sample clock only. If external clock is used:

Delay 7 times clock period + <100 ns.
Jitter ± 1 clock period.

A.2.13 Modulation

Types: AM (double sideband with carrier).
SCM (double sideband suppressed carrier).
Bandwidth: > 500 kHz.
Modulation Distortion:
Modulation Freq ≤ 100 kHz No harmonic > -50 dBc.
Modulation Freq ≤ 1 MHz No harmonic > -30 dBc.
Carrier Suppression (SCM):
> -40 dB

AM Scale Factor: Proportional to programmed amplitude -
Peak Amplitude + Abs(Offset) Ratio of pro-
grammed Vout to Vin
for 100% AM
>2.500 to ≤7.500 V 10:1
>1.250 to ≤2.500 V 5:1
>0.625 to ≤1.250 V 2.5:1
>312.5 to ≤625 mV 1.25:1
>156.3 to ≤312.5 mV 0.625:1
>78.13 to ≤156.3 mV 0.3125:1
>39.06 to ≤78.13 mV 0.1563:1
to ≤39.06 mV 0.07813:1

SCM Scale Factor: 5 V/V.
Scale Factor Accuracy: ±5 % for carrier ≤5 MHz,
±20 % for carrier >5 MHz.

All Scale Factors assume Main Output 50 Ω load.

A.2.14 Interchannel Operation

Interchannel Analog Summing:

Waveform Summing sums the waveform from any one channel into the output of any or all remaining channels. The scale factor from the source channel's amplitude/offset setting to the preattenuated amplitude/offset of the receiver channel is 1:1. Output attenuators on receiver channels are selectable; see below:

Attenuation, dB:	Division, ratio:
0	1/1
-6	1/2
-12	1/4
-18	1/8
-24	1/16
-30	1/32
-36	1/64
-42	1/128
<i>Amplitude Accuracy at 1 kHz:</i>	$\pm 5\%$
<i>3dB Bandwidth:</i>	>12 MHz

Interchannel Phase Control

Two or more channels can be assigned a fixed phase relationship. The "Slave" module must be driven by the "Master's" clock generator and the waveforms must be of the same length and frequency. Any change in phase angle between channels will require one waveform cycle to re-acquire phase lock. Phase control signals use the backplane.

	User Waveforms	Standard Waveforms
<i>Phase Resolution:</i>	360°/# points	0.1°
<i>Phase Accuracy:</i>	\pm Time Skew	$\pm(0.05^\circ + \text{Time Skew})$
<i>Interchannel Time Skew:</i>	< ± 10 ns	

Interchannel Triggering

ARB channels can also use the chassis backplane to "daisy chain" a trigger signal from the "Start" channel, through a number of channels in the "Chain" to the "End" channel. Each channel receives the triggering signal on the backplane from the previous channel, and drives the backplane with its selected Trigger Source to the next channel. The "End" channel can be set up to drive the backplane with its selected Trigger Source back to the "Start" module, closing the loop.

In this fashion, complex and versatile interchannel triggering schemes may be set up. Each channel can have its Trigger Source (the signal that it uses to drive the backplane) and its output waveform set up independently. Trigger Sources include BIT (pulse occurring at the end of a trace), Burst Complete, or Loop Complete.

A.2.15 Clocks

The waveform sample rate Clocks for the ARB channels can be independent or synchronized to a single clock source, as follows:

Sample Clock Sources

<i>Channel clock generator(s):</i>	0.1251 Hz to 50 MHz
<i>Channel external clock input:</i>	DC to 50 MHz
<i>System clock generator:</i>	Derived from any channel's internal clock generator or it's external clock input.

Note

Clock source for each channel is independently selectable.

For Standard functions (Trace Mode CW) the waveform sample frequency (and thus the Clock output from the Master) is 50 MHz fixed. For User-defined functions (Trace Mode Raster) sample frequency is selectable, and the Master's clock output will vary between 25 MHz and 50 MHz with the mantissa of the frequency ([SOURce:] FREQuency: RASTer) parameter.

A.2.16 Options

The standard configuration includes a single Arb Channel and a two button mouse. Options supported include:

001 Additional 50 MHz Arb Channel Module

One module is included with the standard instrument. Up to three additional channels (modules) can be added for a total of four channels in the unit.

001-EM Additional 50 MHz Arb Channel Module

Same as above except channel memory is extended to 128K Points from standard 32K Points of horizontal resolution.

001-EM512 Additional 50 MHz Arb Channel Module

Same as above except channel memory is extended to 512K Points from standard 32K Points of horizontal resolution.

002 3.5" Floppy Disk Drive

Used for Waveform Data storage, 1.44 MByte format, MS-DOS compatible. Recommended for configurations of two or more Arb Channel Modules. Wavetek's WaveForm DSP™ file format is Model 295 compatible and is loaded using Option 002.

004 Rack Mount/Chassis Slides

Used for mounting the chassis in a standard 19 inch EIA equipment rack. Occupies 5 1/4 inches of rack height (see Appendix D).

005 Direct DSO Download

Option consists of a 3 1/2 inch floppy diskette (must include Option 002) with software drivers for uploading waveform data files from commercial Digital Storage Oscilloscopes. DSO models supported and additional information is located in Appendix F.

007 High Voltage Module

Provides high voltage output connector and an external analog summing input connector for each ARB channel up to a system limit of three Arb Channels. Routing of the waveform to High Voltage module is internal (programmable). The High Voltage module must be installed in the channel 4 position. See Appendix G for additional information. Specifications apply for 500 Ω load at 100 Vp-p:

<i>Amplitude range:</i>	10 Vp-p to 80 Vp-p
<i>Amplitude accuracy:</i>	$\pm 5\%$ of setting
<i>Amplitude Resolution:</i>	<0.3 Vp-p
<i>Output Current</i>	80 mA per output <210 mA all three outputs
<i>Max. slew rate:</i>	>200 V/ μ s
<i>3 dB bandwidth:</i>	>700 kHz Internal >700 kHz External Summing Input
<i>Square transition time:</i>	< 400 ns
<i>Square aberrations:</i>	< 5% \pm 100 mVp-p
<i>Square symmetry:</i>	< 200 kHz; 50% \pm 2%
<i>Sine distortion:</i>	<1kHz, \leq 80 Vp-p: No Harmonic > -35 dBc; <1kHz, \leq 80 Vp-p: No Harmonic > -55 dBc; <10kHz, \leq 80 Vp-p: No Harmonic > -45 dBc.
<i>DC offset</i>	\leq \pm 350 mVdc into 500 Ω .

High Voltage Inputs and Outputs

<i>High Voltage Out (5Ω)</i>	100 Vp-p max. into 500 Ω . Output protected against short circuits to ground.
<i>Ext Sum In (1.3kΩ)</i>	10 Vp-p input level produces 100 Vp-p output. Inputs >5Vp clip the waveform's peak. Clipping will not harm the High Voltage Module. Gain Ext In to Output: -10V/V \pm 4%.

A.2.17 AutoCal/Calibration

Each 295 ARB Module contains DC measurement capability. This feature provides the ability to conduct a limited Autocal and self diagnostic. Some parts of the calibration (e.g., filter flatness) require the use of external measurement equipment. The calibration data is stored in EEPROM on each ARB channel module. The Processor accesses the data and uses it to correct the output as required to maintain the specified performance.

Performance specifications apply within the specified environmental conditions after a 20 minute warm up period. Specifications are subject to change without notice.

A.3 GENERAL

A.3.1 Front Panel Interface

The front panel contains a 320 x 200 pixel Liquid Crystal Display that supports a Graphical User Interface. Data entry is via the 42 keys on the front panel and/or the provided mouse.

A.3.2 Remote Interface

The Model 295 Arb adheres to the Standard Commands for Programmable Instruments (SCPI) remote programming format Version 1992.0, February 1992 (refer to Appendix C for Conformance Information and the SCPI manual for further information). SCPI is an industry standard language for remote instrument programming. It addresses a variety of test and measurement instrument requirements. Using the provided IEEE-488 (GPIB) and RS-232 interfaces, the Model 295 Arb can be controlled using the SCPI language and the appropriate controller. Root level commands include:

OUTPut	SOURce	STATus	SYSTem
TRIGger	CALibration	INITiate	RESEt
TEST	TRACe	MMEMory	DISPlay
HVOLTage			

The Model 295 also supports all IEEE-488.2 Common Commands mandated for use with SCPI.

A.3.3 Physical

Dimensions

<i>Width:</i>	16.75 in (42.55 cm)
<i>Height (with Feet):</i>	5.82 in (14.79 cm)
<i>Height (Rack Mount):</i>	5.22 in (13.26 cm)
<i>Depth (Overall):</i>	18.00 in (42.87 cm)

Weight

<i>Basic unit (1 Channel):</i>	25.5 lbs (11.6 kg)
<i>Arb Channel Module:</i>	2.4 lbs (1.1 kg)
<i>Floppy Disk Drive Kit:</i>	1.1 lbs (0.5 kg)

Power

< 60 VA plus 60 VA per channel

<i>Line Voltage:</i>	90 to 253 Vac, 47 to 63 Hz
----------------------	----------------------------

A.3.4 Environmental

MIL-T-28800D for type 3, class 5, except as noted

Temperature Range:	±10°C of AutoCal for specified operation except as otherwise noted; Operates 0°C to 50°C maximum range; Storage limits are -20°C to +71°C.
Warm-up Time:	20 minutes for specified operation.
Altitude:	Sea level to 10,000 feet for operation; Sea level to 15,000 feet for storage.
Relative Humidity:	0 to +10°C: Not Controlled (non-condensing). +11 to +30°C: 95±5% relative humidity max. +31 to +40°C: 75±5% relative humidity max. +41 to +50°C: 45±5% relative humidity max.

Reliability: >4000 hours MTBF at 25°C ground benign
(1 Channel System);
>2500 hours MTBF at 25°C ground benign
(4 Channel System & w/o disk, mouse).
MIL-HDBK-217 calculation at 50% component stress.
Calibration interval > 12 months

Shock/Vibration: 40G max. / Sinusoidal of 5 to 55 Hz with 2G max.

Safety: Designed and tested to the requirements of IEC-348.

Appendix B contains six menu quick reference guides. One for each of the Model 295 main menus:

Channel Setup Screen guide,

Trigger Setup Screen guide,

Waveforms Screen guide,

Sequence Screen guide,

Instrument Screen guide,

Utilities Screen guide.

For details on items in these guides, refer to section 4 of this manual.

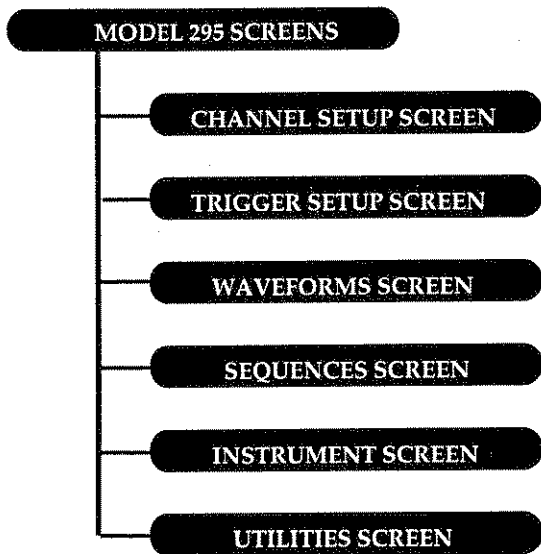

Legend:

*Major Screen:
Select via Screen keys or
SCREEN menu.*



Screen "button" or MENU Item.



Screen Title



*Submenus and Contents
Listings.*

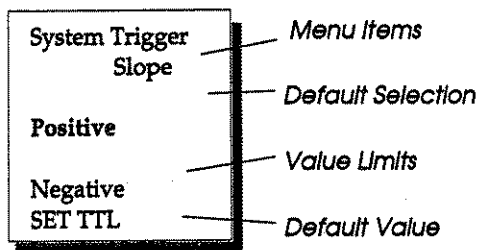

Figure B-1. Menus Quick Reference Legend.

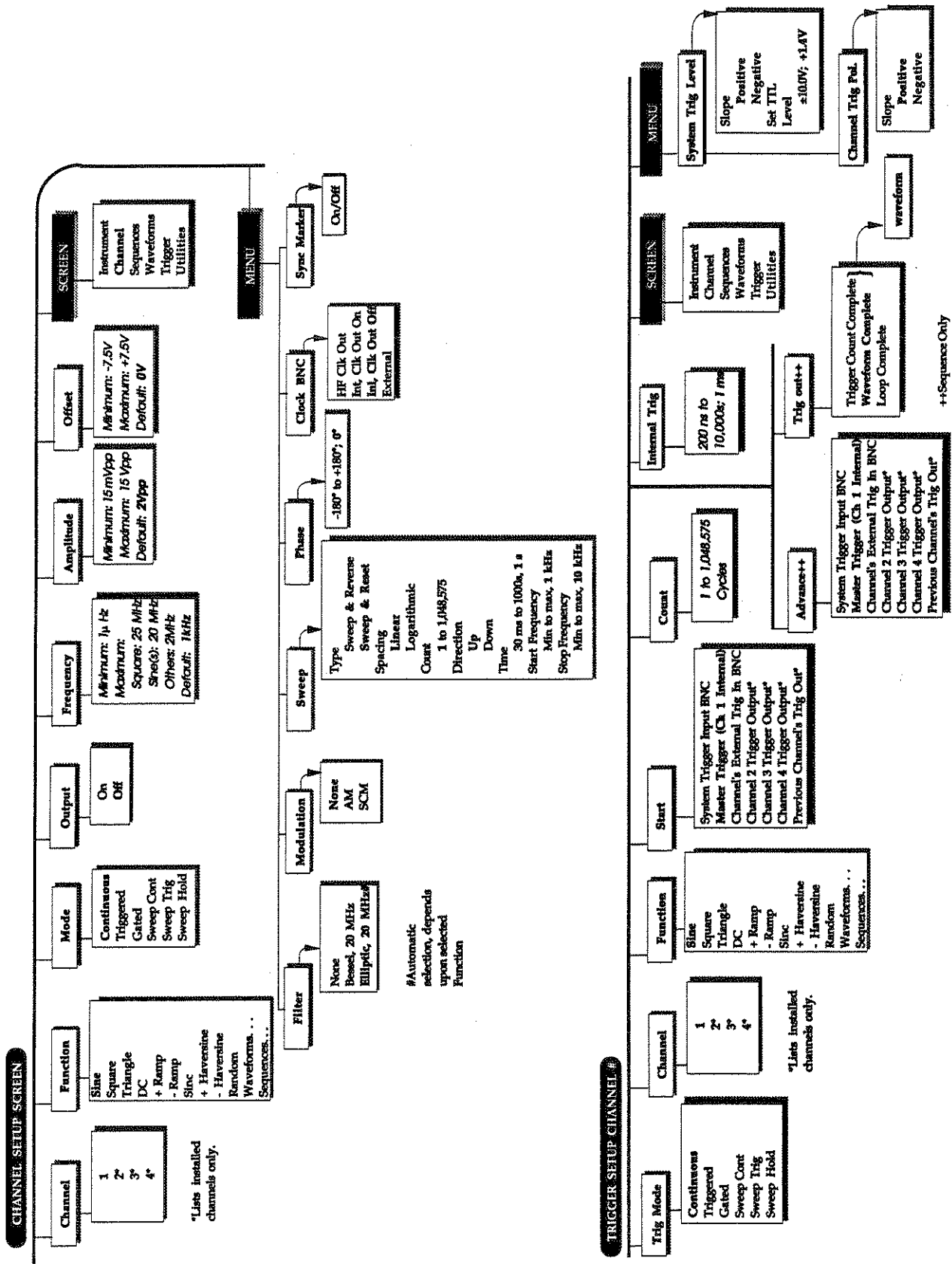

Figure B-2. Channel and Trigger Setup Screens.

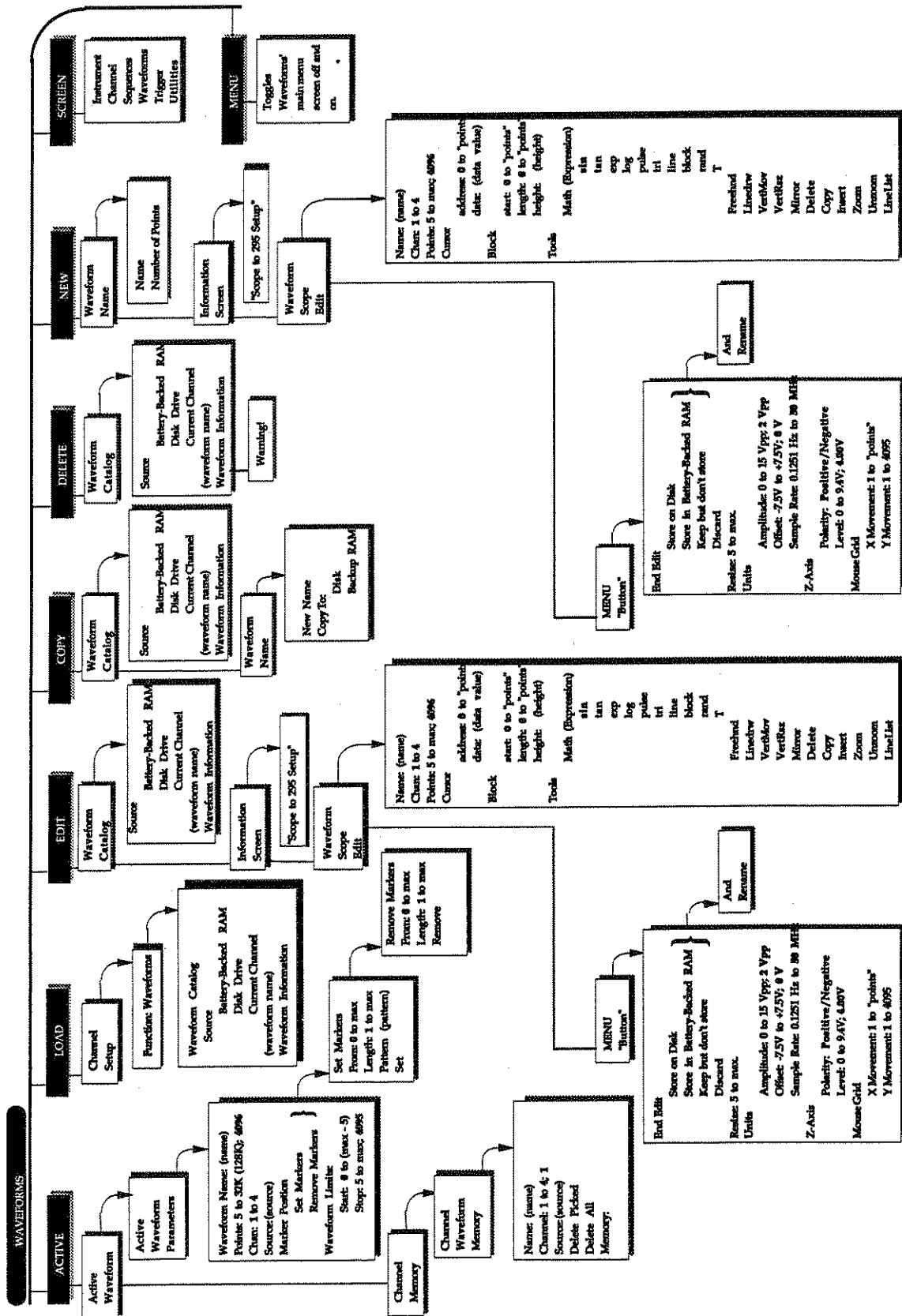

Figure B-3. Waveforms Setup Screen.

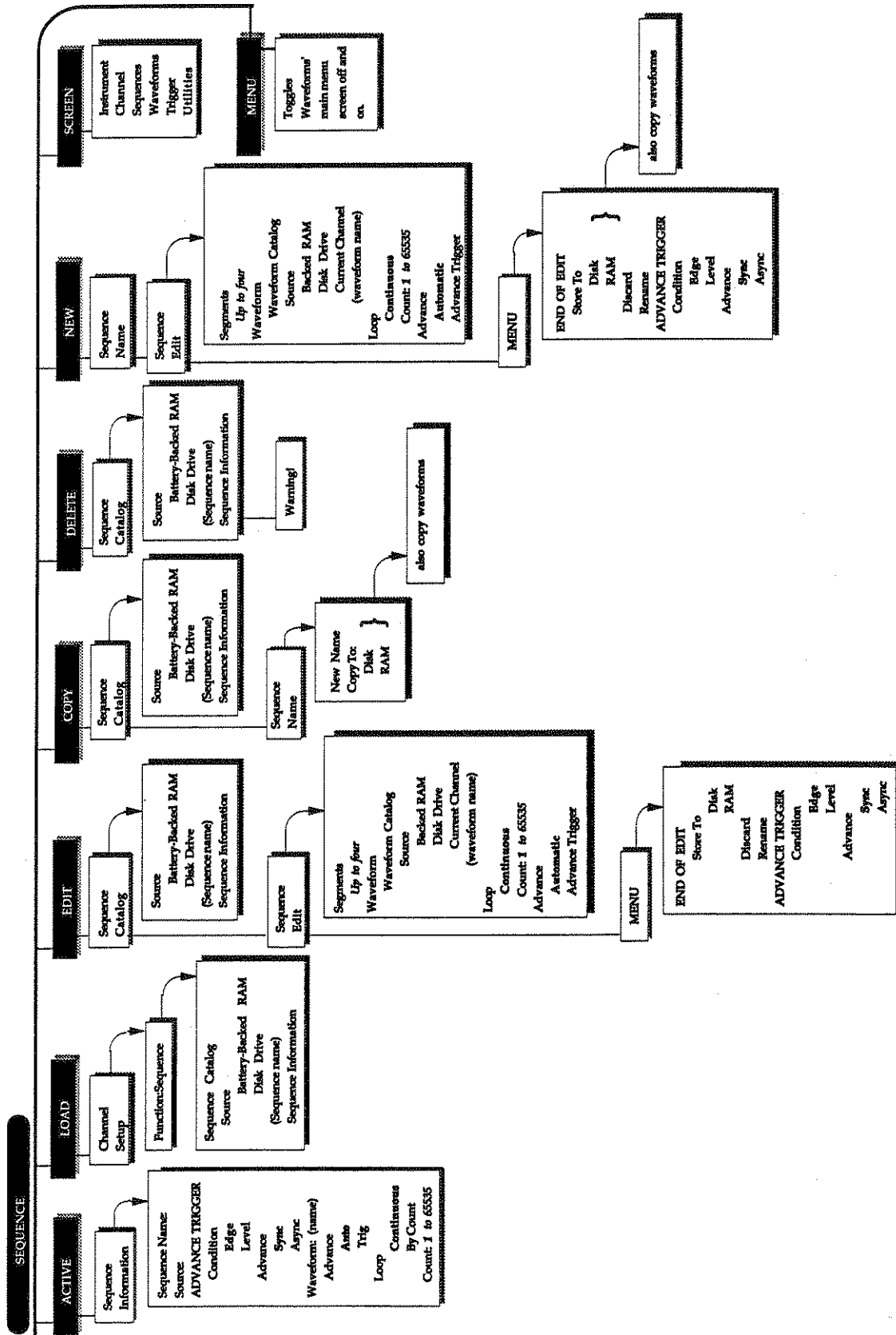

Figure B-4. Sequence Setup Screen.

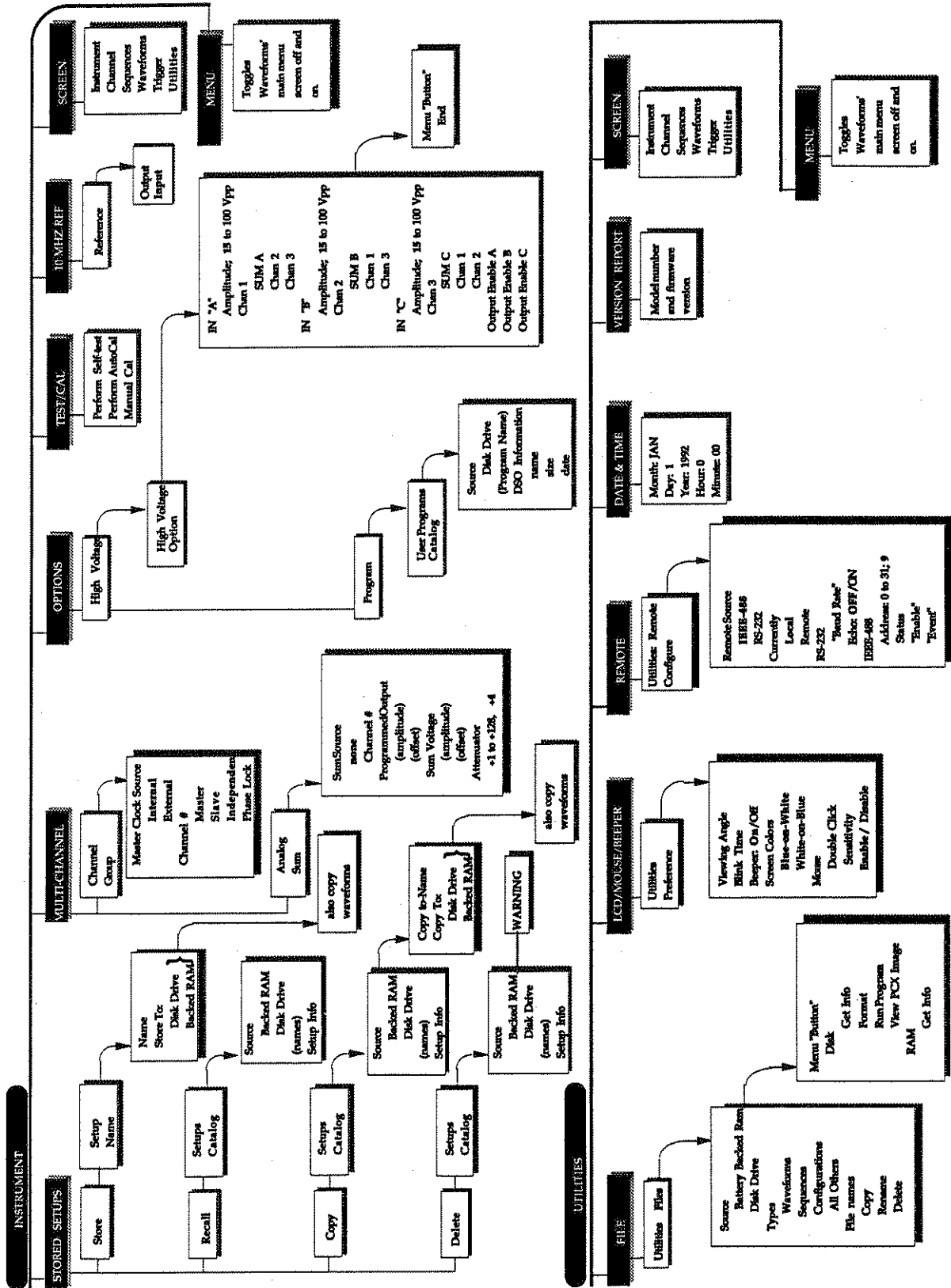

Figure B-5. Instrument and Utilities Setup Screens.

Appendix C contains additional information for the Standard Commands for Programmable Instrumentation (SCPI) that is not covered in detail in the model 295 Command Reference, Section 5 of this manual. First is a "SCPI Primer" intended to provide the first-time SCPI user/programmer with a quick overview of the information contained in SCPI 1992 Specification. Following the "primer" is a number of figures representing the SCPI Command set of the model 295 given in a "Command Tree" rather than the common "Command Table" format. Finally, this appendix includes the "SCPI Conformance Information" required by the specification.

SCPI PRIMER

SCPI (Standard Commands for Programmable Instruments) traces its lineage to IEEE 488.1 and IEEE 488.2. Although the IEEE 488.2 standard addressed some instrument measurements, it principally dealt with common commands and syntax or data formats. Please refer to the IEEE 488.2 and SCPI reference manuals for more information.

The IEEE 488.1 relates to the physical connection between the instrument and its remote control unit; how the data is transmitted between the two; and the method used to determine master and slave.

The IEEE 488.2 encompassed and built upon IEEE 488.1 by adding syntax and data requirements for the communication path. In addition, it also defined the commands which were to be common to any and all units, and the query format for data retrieval from the remote instrument.

With SCPI, a variety of modular instruments have a universal language, even though they have different functions and manufacturers. SCPI added the fine detail of instrument set-up by establishing a hierarchy of standard command formats and subsystem routing, reducing multiple ways to control similar functions. An example of vertical consistency (same instrument type) would be multimeters from different manufacturers implementing the command to measure a value of DC voltage in the same manner using the *Measure sub-system*. An example of horizontal consistency (different instrument types) would be different instruments using the same command to trigger a function using the *Trigger subsystem*. Refer to Figure C-1. Queries of the instrument by the controller result in well-defined status response and measurement data. By building on the IEEE 488.2, all of the earlier commands that it had defined have become a part of SCPI and, to the limit that an instrument can be operated by them, they are valid.

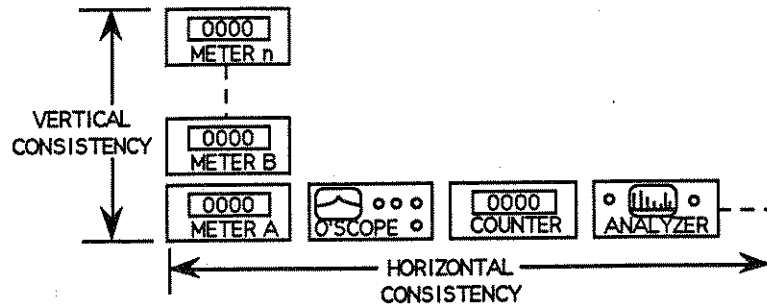

Figure C-1. Command Consistency

The user need not be concerned about the interface commands, the common commands or the syntax and data structures, they are IEEE 488.1 and IEEE 488.2 definitions and have not changed; they are encompassed within SCPI. Not all instruments use all commands, but all instruments use the same command format. Using the language rules and the hierarchical nature of the command structure, new commands, parameters, and subsystems can be developed from the existing primitive elements and commands as new instruments are introduced.

The hierarchy of subsystem commands in SCPI is called a **Command Tree** (sometimes also called a **Command Flow Chart**). The SCPI Command Tree is up-side-down, the Root is at the top with branches extending downward, ending with the parameter required for the branch function. Refer to Figure C-2. There is only one route to travel to reach the destination keyword or parameter on the selected branch. More than one command may have the same keyword, but on different branches. These commands usually perform a similar function in the respective branches, however, each can only be reached by traversing a unique path.

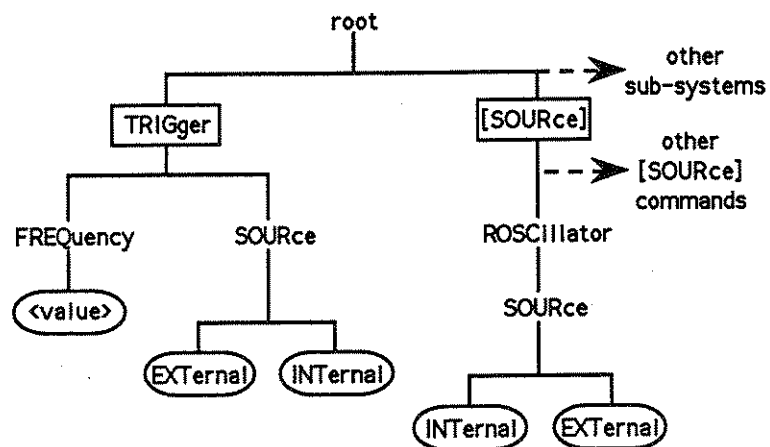

Figure C-2. Same Keywords In Different Subsystems

The command hierarchy can also be represented by a **Command Table** and by **Syntax Diagrams**. An example of each method is illustrated.

Parameters

The parameter specifies the finest detail that is required in a branch. Most parameters have a defined default value at power-up or *RST. Parameter defaults are specified in the manual for each instrument. There are three major types of parameters: *Character* (Discrete), *Decimal Numeric*, and *Boolean*.

Character parameters are a one word character label, usually one of a number choices, that defines a characteristic (e.g. ZCROs - the abbreviation for Zero Crossings). Failure to include a numerical suffix with a *Character* parameter requiring one, will result in issuing a command with the lowest value suffix (e.g. the command TTLTrg without any suffix will default to TTLTrg0).

Decimal Numeric has an extended set that may be implemented. *Decimal Numeric* may not be used as a subset (e.g. 1 of n lines), but may be used as a value definition (e.g. start value = 10). Subsets are implemented by using a suffix with a discrete (e.g. Line2). *Decimal Numeric* also covers the "label" type of parameter, the signal name (e.g. SIN1). The extended numeric set covers the special numbers MAXimum and MINimum which are required and DEFault which is optional.

Boolean parameters can have one of two values, usually ON or OFF. *Boolean* values can also be represented by "1" or "0" on the command line. Queries requesting a *Boolean* value will always return either "1" or a "0".

A SCPI convention shows parameters in text and on the Command Tree with angle brackets (<>) if they are values or names to be entered by the user. Parameters with a character (discrete) keyword or Boolean parameters do not use the angle brackets. A Wavetek convention shows parameters in the command tree enclosed within an oval "box". The default parameters that are selected at power-up or *RST are shown in shaded oval "boxes".

Queries

Any command that sets a value, can be queried about the current value of the setting. The query form of the command ends with a question mark (?). Some commands are defined as queries only and can be identified by the question mark used after them in the command tree. Some commands are events only and do not have a query form. These can usually be identified by their action nature such as DELete or IMMEDIATE. The values of the special numbers of MAXimum, MINimum, and DEFault may also be queried.

SCPI Punctuation and Syntax

Keywords can be abbreviated or used in full. SCPI requires the exact abbreviation or the exact full spelling only; capital or lower case letters have equal weight. The long form of the keyword may be either a single word or a phrase which has been abbreviated to a single word. The SCPI convention is to use the entire keyword in any text or instructions with the accepted abbreviation shown in capital letters. In addition, Wavetek makes the capital portion bold to show the minimum command requirements at a glance, and sets it off by using a different typeface. For example,

FREquency

Common commands must start with an asterisk (*). SCPI commands start with an optional colon (:). Each time a colon is inserted in the command line, the "pointer" is instructed to move down the branch which has the keyword immediately following. A semi-colon separates a string of commands on one line. If a colon does not follow the semi-colon, the "pointer" remains at the same level. A colon following the semi-colon will set the "pointer" back to the root. The commands do not become effective until a "Program Message Terminator" is received at the end of the command line. An incorrect command line will generate an error message.

Condensed Rules:

- Power-on and Reset

After power is applied, the command "pointer" is set to the root and all parameters to default values (*RST does not set the Trace memory to default values).

- Command line termination

When the command line is terminated with a Program Message Terminator, the "pointer" is set to the root level.

- Colon

The optional leading colon in a command line indicates the keyword immediately following is at the root level (a subsystem).

A colon between command keywords indicates the pointer is to step down one level to the immediately following keyword.

- Semi-colon

The semi-colon separates commands within the same message without changing levels.

- Whitespace (space bar or tab)

Whitespace must be used to separate commands from parameters. Whitespace must not be used within a command keyword. Otherwise, SCPI usually ignores the whitespace.

- Comma

When a command requires a series of parameters, they must be separated by commas.

- Question Mark

The question mark is placed after the program header creating a query. A parameter may be placed after the question mark where appropriate (for example, ...LIMits? <trace name>). Some event commands do not have a query form (for example, DELete). Some commands are queries only (for example FREE?).

- Common Commands

Common commands (*RST, *TRG, etc.) are acted upon the same way regardless of which subsystem or into which level of the SCPI test program they are written. After execution of the common command, the SCPI command "pointer" will return to the point where it was interrupted (the exception is *CLS, the "pointer" is setback to the root).

The *RST command will reset all subsystems to the default values except the Trace memory; it does not set the "pointer" back to the root.

Text Symbols

- Square brackets

Commands or portions of parameters that are optional are enclosed by square brackets ([]).

- Angle brackets

Angle brackets (< >) enclose parameters that are to be entered by the user, usually either numeric label (names) or numeric data (levels, values).

- Vertical line

The vertical line (|) represents an "exclusive OR", one of the values shown must be used.

TRACE NAMES (numeric label data)

The following restrictions govern parameter names (user waveform names):

1. They cannot exceed 12 characters in length, preferred length is 4.
2. They must not have any embedded whitespace.
3. They *must* start with an alphabetic character. They cannot start with a numeric, a whitespace, or an underscore.
4. All alphanumeric characters may be used, both capital and lower case. The underscore (_) may also be used.
5. There is no abbreviation for the users trace name, it must be used as defined.

The command hierarchy can be represented in three ways; the COMMAND TREE, the COMMAND TABLE, or the COMMAND SYNTAX DIAGRAM. All three are illustrated on the following pages. Refer to Figure C-3, the Example Command Tree.

Example Command Tree

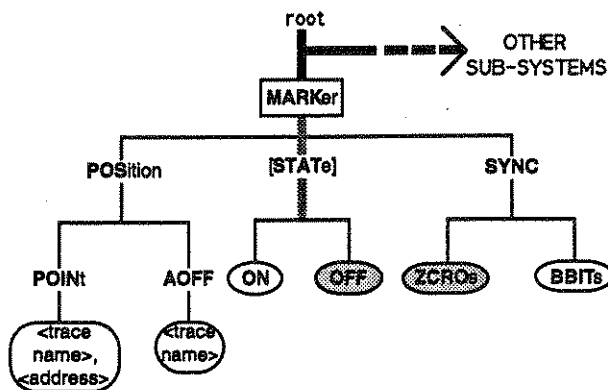

Figure C-3. Example (Marker Subsystem) Command Tree

Example command lines for this subsystem follow. Assume a trace name and size have been entered and a trace name is currently selected. Only the entered trace name is acted upon by the commands except in the case of global commands like DELeTe:ALL or MODE, etc. The long form of the keywords are given with the approved (or Wavetek selected) abbreviations in capitals. Items in **bold**, with the exception of optional commands, are minimum requirements.

The first character on the command line is the colon (:). This places the "pointer" at the "root" and just above all subsystems. The leading colon is optional if the command pointer is already at the "root". The following example shows the development of the command line by "walking" down the tree. Select the MARKer subsystem by entering:

```
:MARKer
```

There are three branches in the Marker subsystem, select SYNC by entering it after MARKer:

```
:MARKer:SYNC
```

Sync has two discrete type parameters. Select one, ZCROs. Enter a <space>, then ZCROs, then a <program message terminator> (<PMT>). The <PMT> is not normally shown in command lines, but is shown below for reference. The PMT will enter the command string into the controller.

```
:MARKer:SYNC ZCROs <PMT>
```

If, after setting markers at various locations in the waveform, the markers are in unacceptable locations, turn them All Off using the AOFF sub-command (AOFF has no abbreviations).

```
:MARKer:POSition:AOFF <trace name>
```

Now, set the marker(s) to the position(s) desired. This command sets only one marker position (high) at a time; if more than one is desired, repeat the command for each position. There must *not* be any whitespace between the comma and either parameter. The <address> is a numeric value.

```
:MARKer:POSition:POINT <trace name>,<address>
```

The desired marker selections have been completed. Now, turn the marker ON. This command can use one of several formats, the complete command follows:

```
:MARKer:STATe ON
```

Because the STATE command is optional (the square brackets, [], in the command tree show this) it is not necessary to be entered on the command line:

```
:MARKer ON
```

Because the ON parameter is Boolean, it can be replaced by "1", if desired:

```
:MARKer:STATe 1
```

Both of the options have been exercised in the following command line. The syntax selected for the command depends upon the user.

```
:MARKer 1
```

Not including the query, the commands could have been entered in a string of four commands on one program line, using the semi-colon and colon, as follows:

```
:MARKer:SYNC ZCROs;POSition:AOFF <trace name>;POINT  
<trace name>,<address>;:Marker 1
```

Enter a request for the marker state (this does not change the state).

```
:MARKer:STATe? or :MARKer?
```

Because the marker has been turned ON, the Boolean response will be:

```
1
```

Example Command Table

The command tree can also be presented as a table. The hypothetical instrument command tree portion of Figure C-3 is shown below as table C-1. The symbols used with the tree are also used with the table.

The angle brackets (< >) indicate the parameter is entered by the user. Lower case text between the angle brackets show the parameter that is expected. ON/OFF are Boolean parameters. Discrete parameters often appear as command keywords in the command table, but must not be confused; a whitespace is still required before them on the command line. All parameters have manufacturer specified default values which will exist at power-up or *RST. Numerical values entered, which are out of range for the branch, will not be acted upon and will return an error when the SYSTEM:ERRor? query is sent.

The square brackets ([]) are optional commands that are not required in the

command line, but may be used for documentation clarity. Some parameters or portions of parameters may be optional and will be shown with square brackets around them.

Table C-1. EXAMPLE MARKER COMMAND TABLE

COMMAND	PARAMETERS	PARAMETER TYPE
:MARKer		
POSITION		
POINT	<name> <address>	numeric (label) numeric
AOFF	<name>	numeric (label)
[STATe]	state (optional)	Boolean
SYNC	sync detector type	discrete

Under the "Command" heading in the table, the subsystem command is not indented. Each sub-command is indented showing the level of subordination. The Parameter column indicates the parameter expected for the command. The Parameter Type column shows the type of parameter for the sub-command.

Example Command Syntax Diagrams

The command list can also be presented as a syntax (or *railroad*) diagram. The hypothetical instrument command tree in Figure C-3 is shown on the following pages as railroad diagrams. Some symbols used with the tree are also used with the diagram.

Railroad diagrams (so called because they look like railroad layouts from above) are another way to present the command flow. There is a railroad diagram for each command in a subsystem. As with the command tree and the command table, railroad diagrams have some unique symbols.

 The rectangular box contains command and subsystem keywords with their abbreviation in capital letters.

 The oval "boxes" contain parameters; shaded boxes are default. The angle brackets (< >) contain user entered parameters.

 The circle encloses punctuation ("sp" implies whitespace).

 The arrow shows the command direction flow. The flow is usually from left to right, but the command may contain loops flowing in other directions.

Figure C-4 shows how the sync is selected, the query form, and the parameters available using the "railroad" syntax diagram format. The bypass around the leading colon indicates it is optional in the command line. The default parameter is shown by the shading. At each place the line splits, a decision must be made which path will be followed. The command is completed when the exit arrow has been reached.

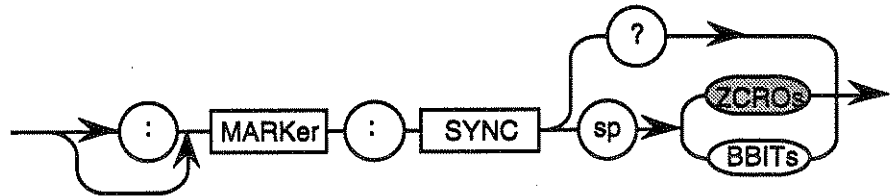

Figure C-4. Sync selection

Figure C-5 shows the All Off command. There is no query form of the command, AOFF is an event.

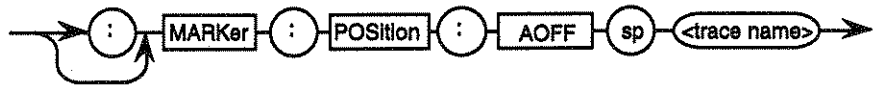

Figure C-5. All markers OFF command

Figure C-6 shows the command for setting the point address.

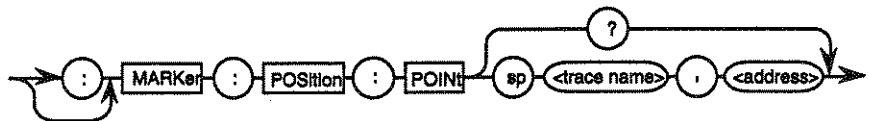

Figure C-6. Set the marker point address

Figure C-7 shows the bypass around the optional STATE command. The entire Boolean parameter complement is in the diagram with both OFF and "0" shown as default. The OFF parameter is equal to "0", and ON is equal to "1"; equal parameters are interchangeable in the command line.

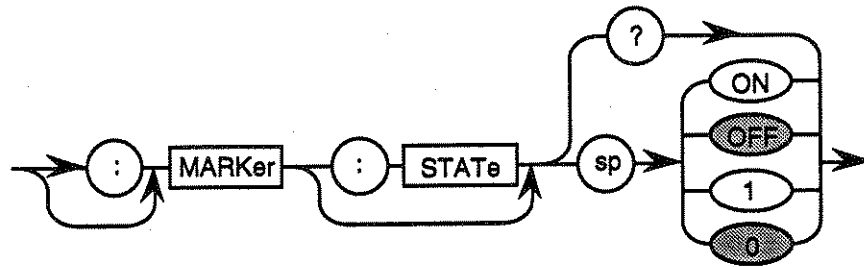

Figure C-7. Set the marker state.

The query to show the output state will only return the Boolean values of "1" or "0".

Low Level Interface Commands

The Arb responds to the following low level VXIbus interface commands. These are issued by its commander. Refer to the VXIbus specification for further information.

ANOP Abort Normal Operation

This command causes the Arb to cease its normal operation as fast as possible. It resets the *ready* bit in the Status register to 0. The unit is reconfigured to the default state; the power-up memory test is NOT performed. It has the same effect as *RST and *CLS.

BNOP Begin Normal Operation:

This commands the Arb to begin normal operation. The *ready* bit in the Status register is set to 1 and the device is ready to receive data.

CLE Clear

Upon receiving the clear command, the Arb removes all output data in the VXI Data Low register. The Arb will discard all data due for output from operations currently in progress and become ready to receive a new command; the input and output queues are cleared. The *read ready* bit in the Response register will be reset to 0. The *Err** bit of the Response register will be de-asserted and any pending *read protocol error* command responses will be canceled.

ENOP End Normal Operation

The Arb ends its normal operation in an orderly manner without any time limit constraints. Incoming signals are no longer processed. The *ready* bit of the status register is reset to 0. The current Arb configuration is maintained.

ICOM Identify Commander

The Commander uses this command to tell the Arb its logical address.

RPE Read Protocol Error

The VXIbus commander uses this command to query the cause of the last protocol error.

RPR Read Protocol

The VXIbus commander uses this command to find out what protocols in addition to the Word Serial protocol that the Arb supports. The Arb supports I, I4, EG, and RG.

RSTB Read Status Byte

This command is used by the Commander to read the status byte from the Arb.

MODEL 295 SCPI COMMAND TREES

Figures C-8 through C-15 provide the programmer/operator with a complete set of SCPI Command trees for the model 295. These trees are an alternate method (to the Command Table) of constructing syntactically correct SCPI commands.

MODEL 295 SCPI COMMAND TABLE

Table 5-1, SCPI Command Summary, and Table C-2, model 295 SCPI Command Syntax, provide the programmer/operator with a complete set of SCPI Commands for the model 295. The Command Table is the primary means of constructing syntactically correct SCPI commands.

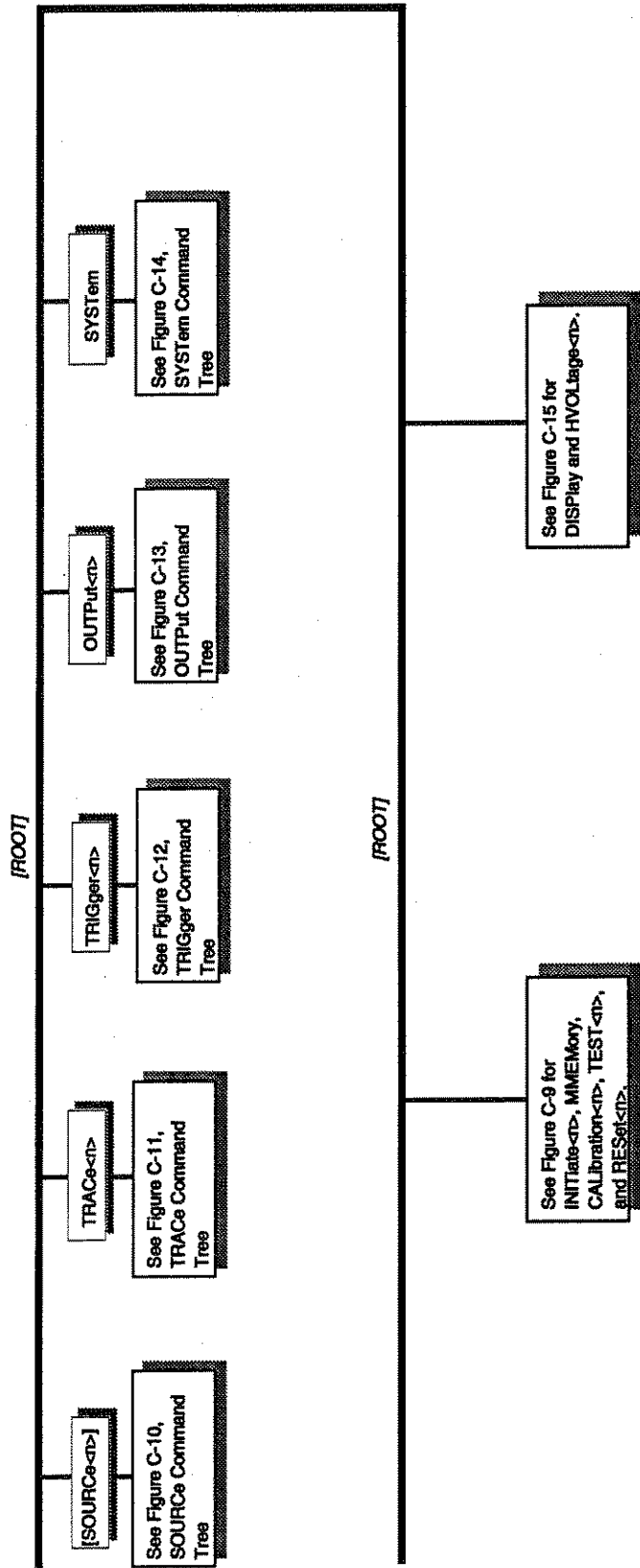

Figure C-8. Subsystems (Root Node)

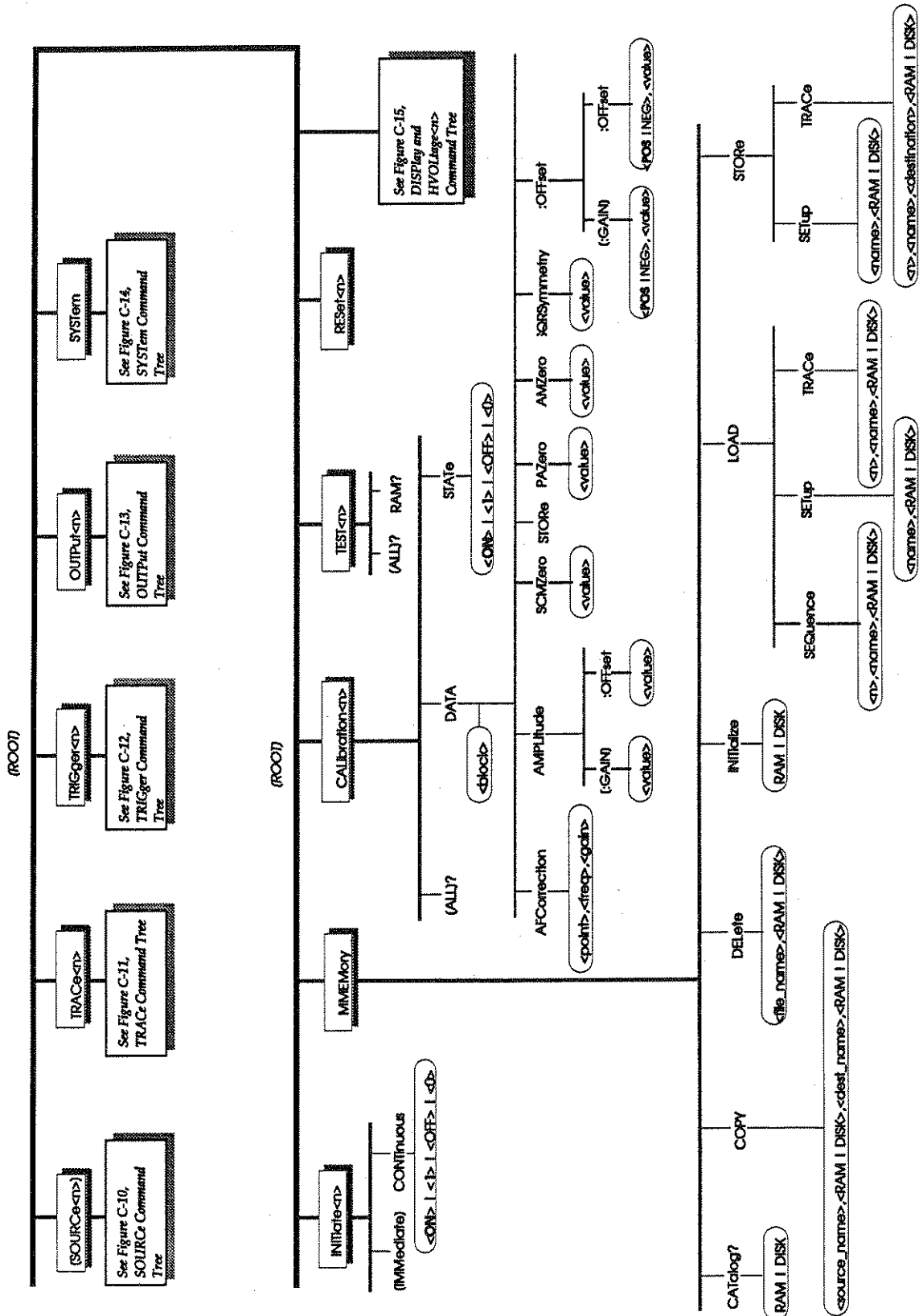

Figure C-9. INITiate, MMEMory, CALibrate, TEST, and RESET Subsystems

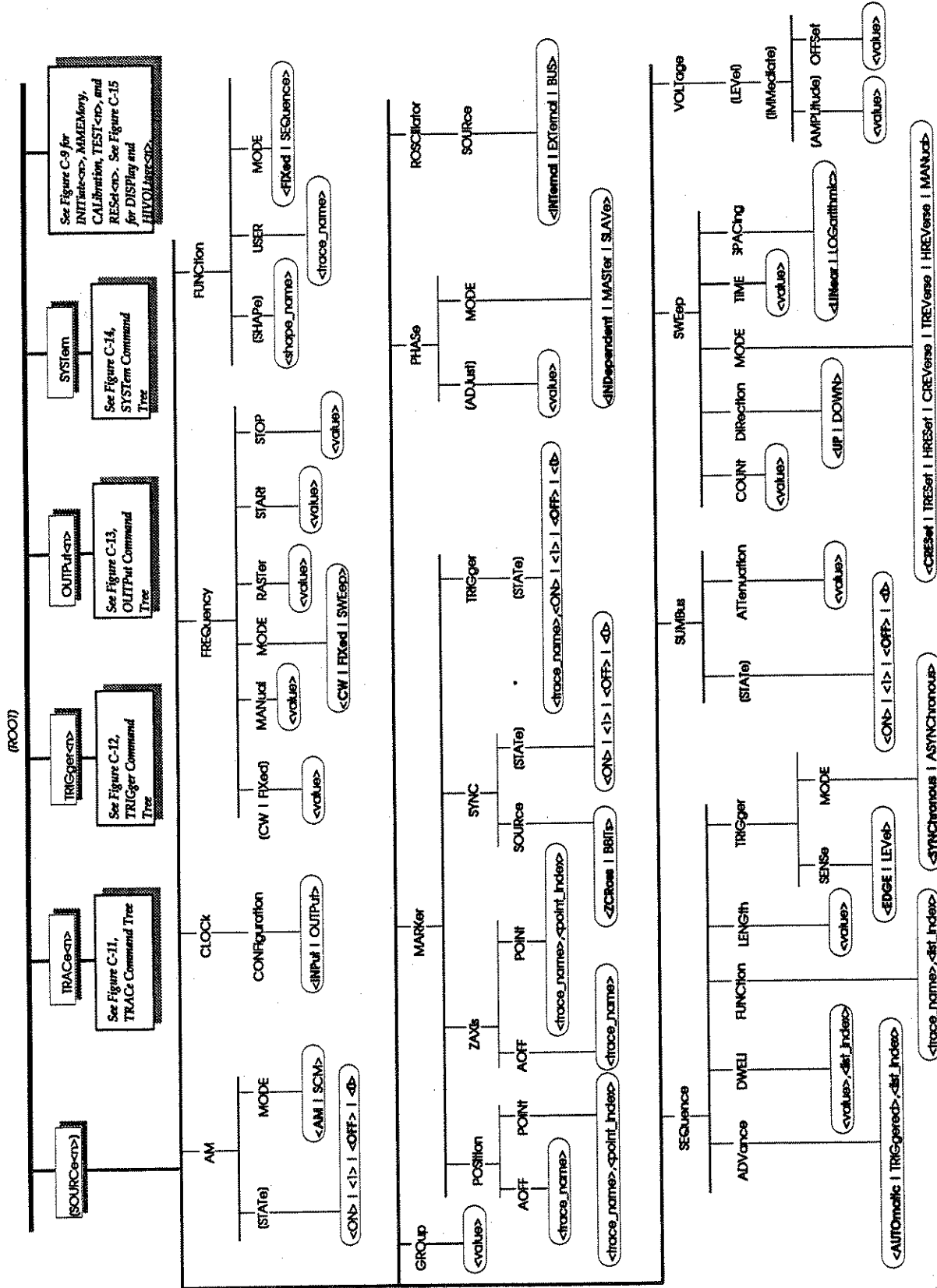

Figure C-10. SOURCE Subsystem

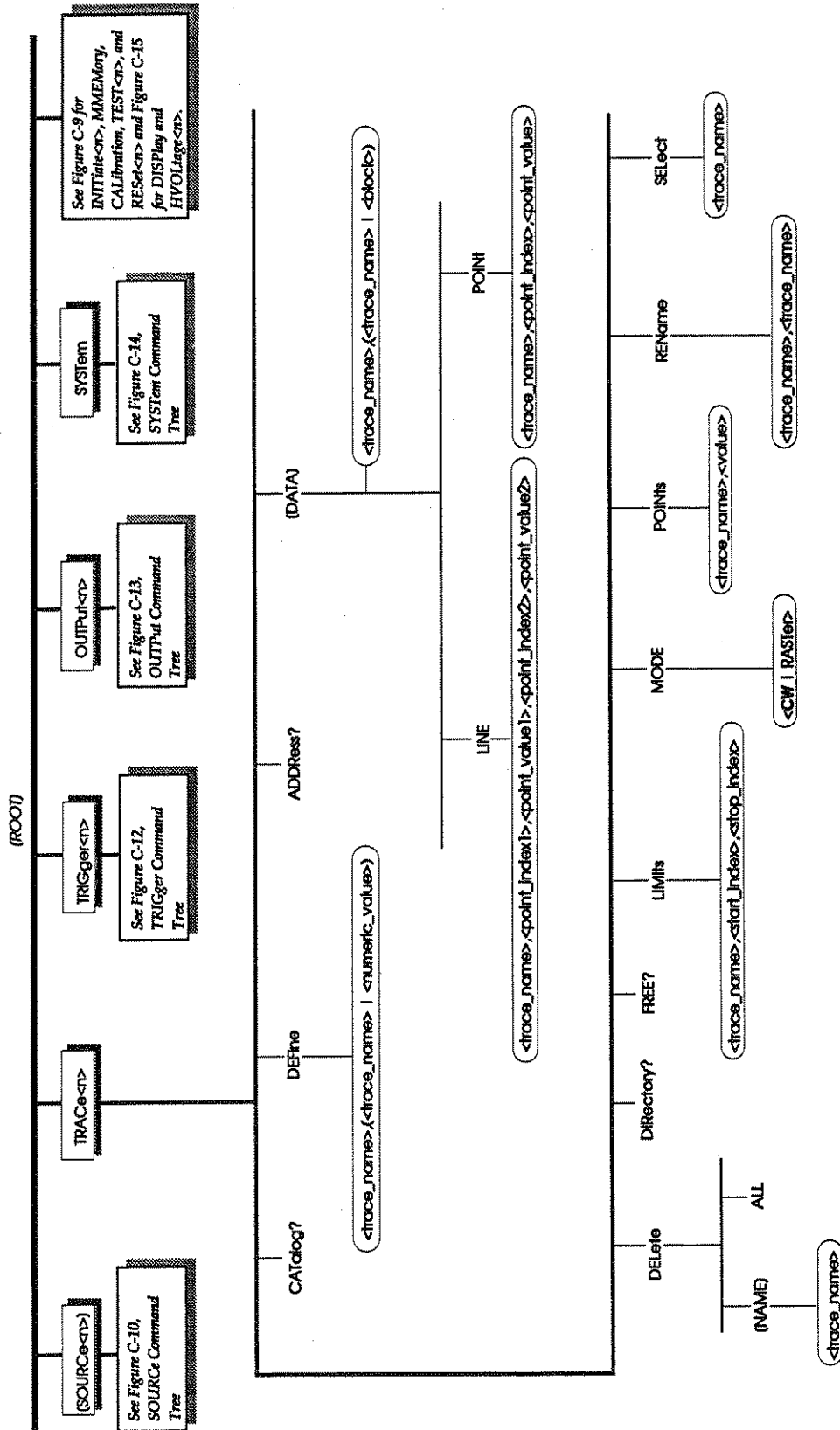

Figure C-11. TRACe Subsystem

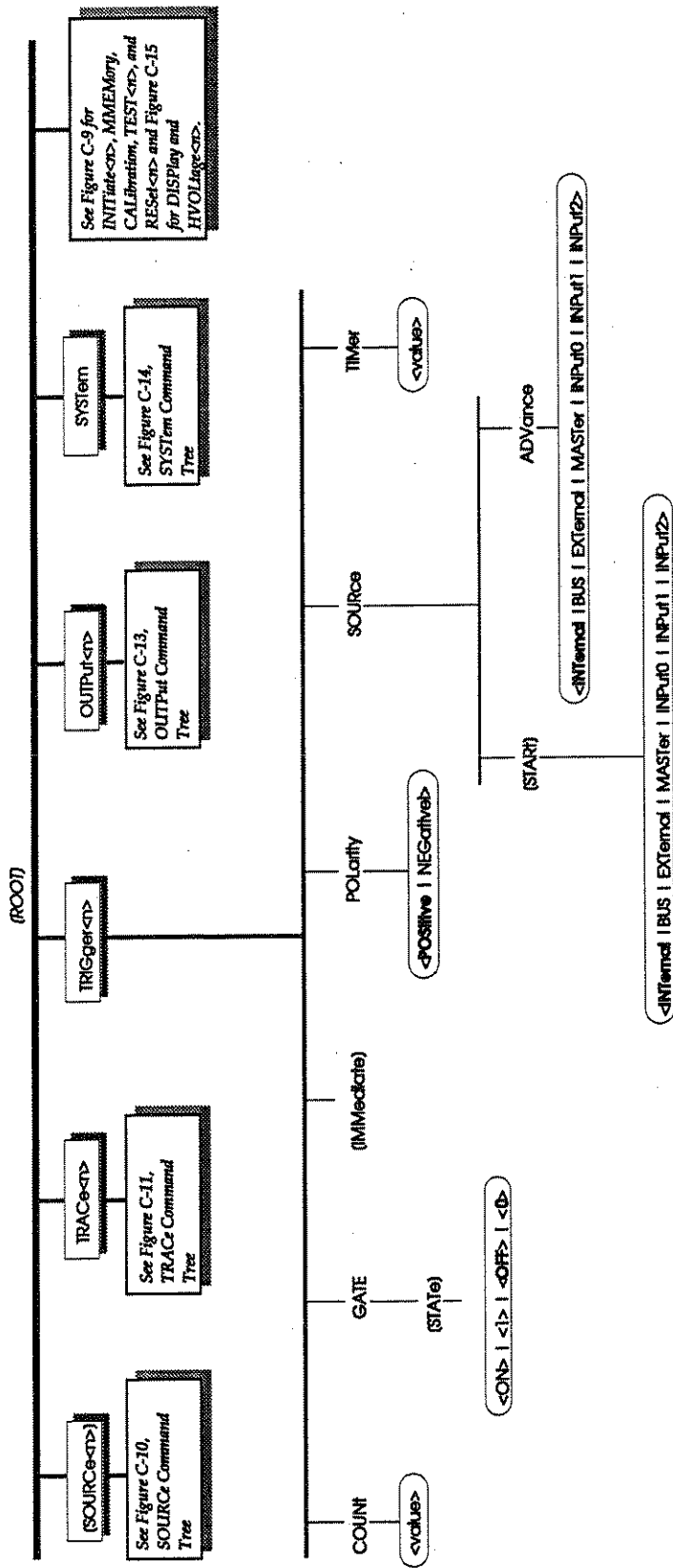

Figure C-12. TRIGGER Subsystem

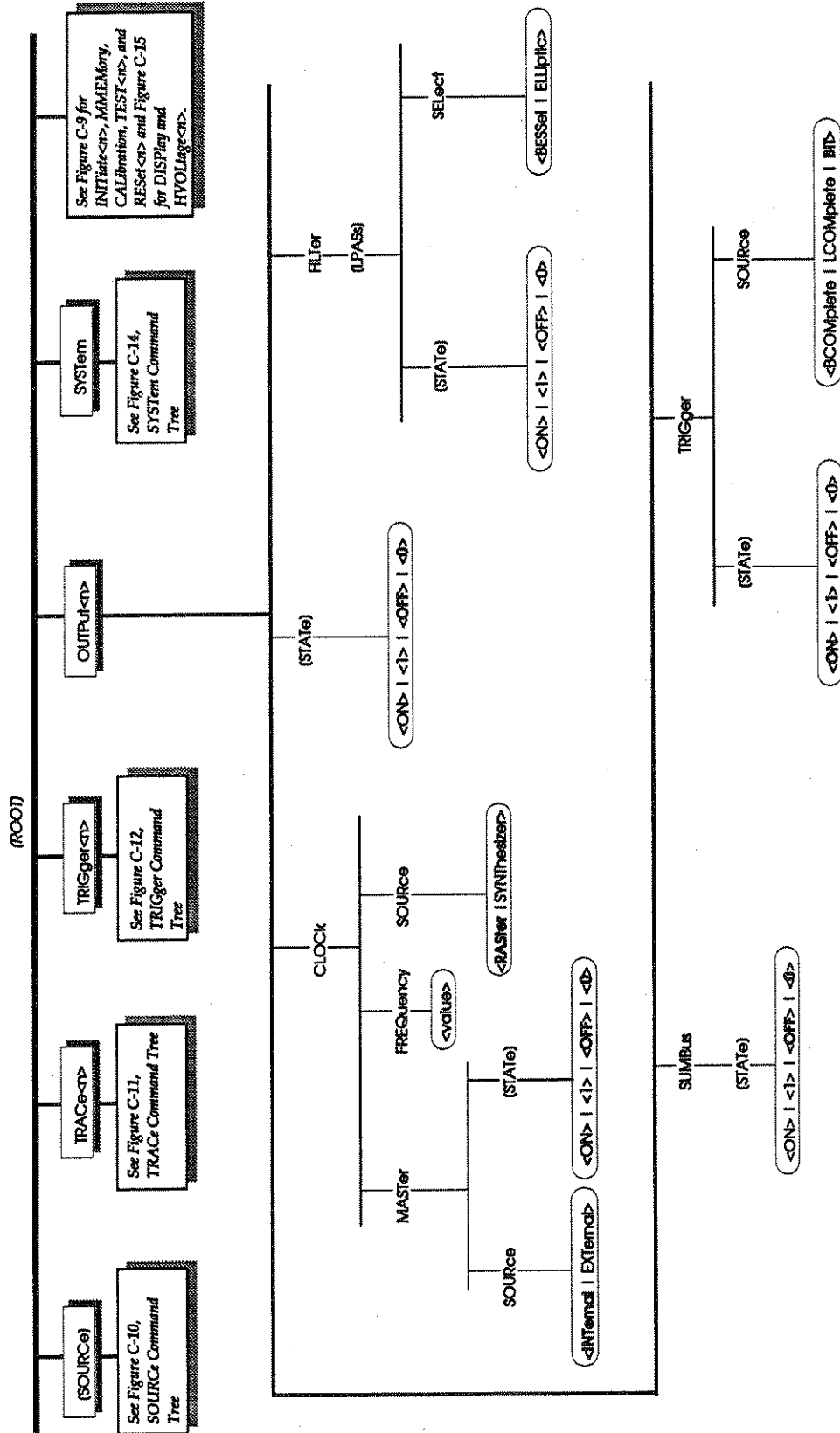

Figure C-13. OUTPUT Subsystem

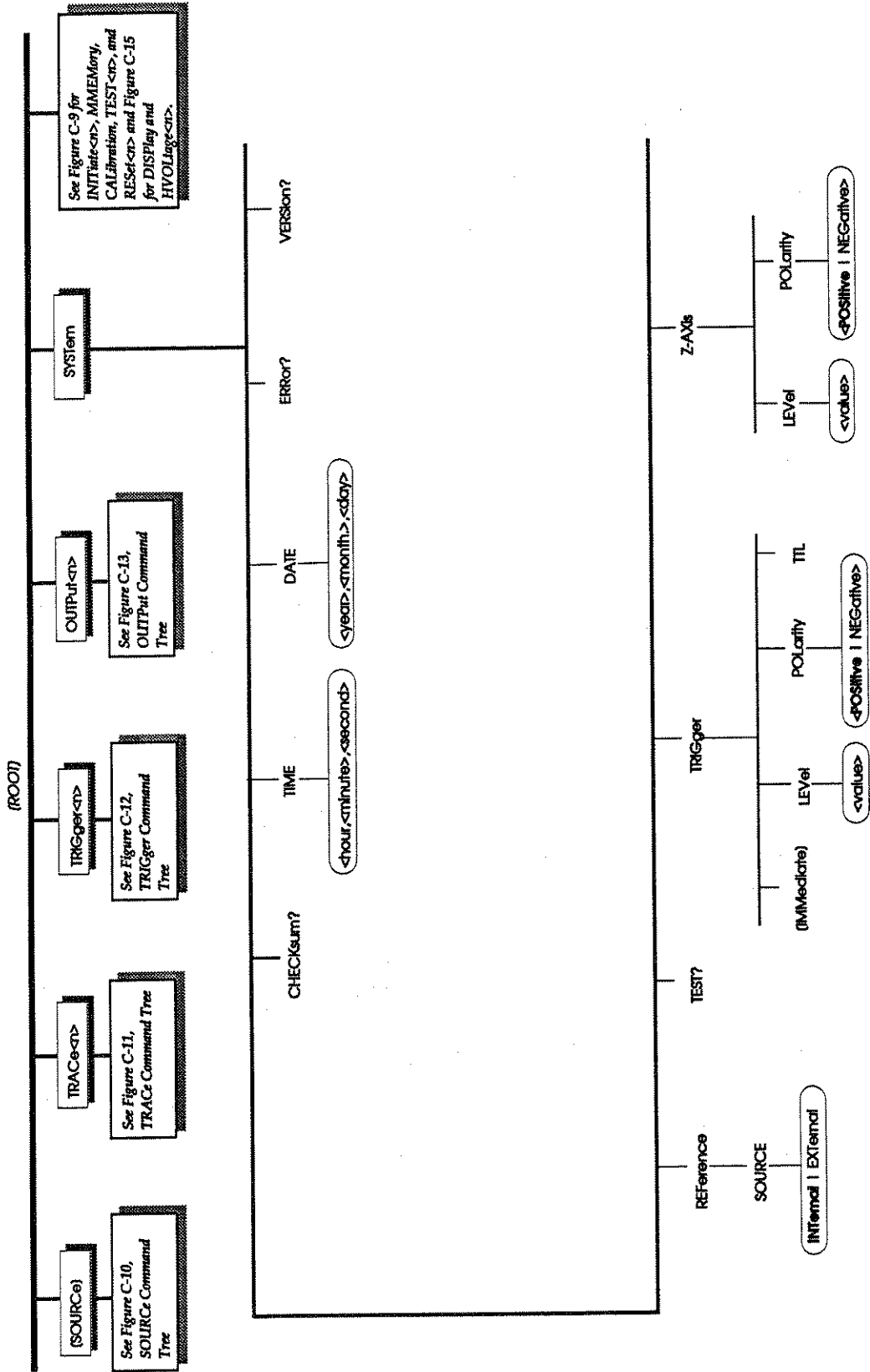

Figure C-14. SYSTEM Subsystem

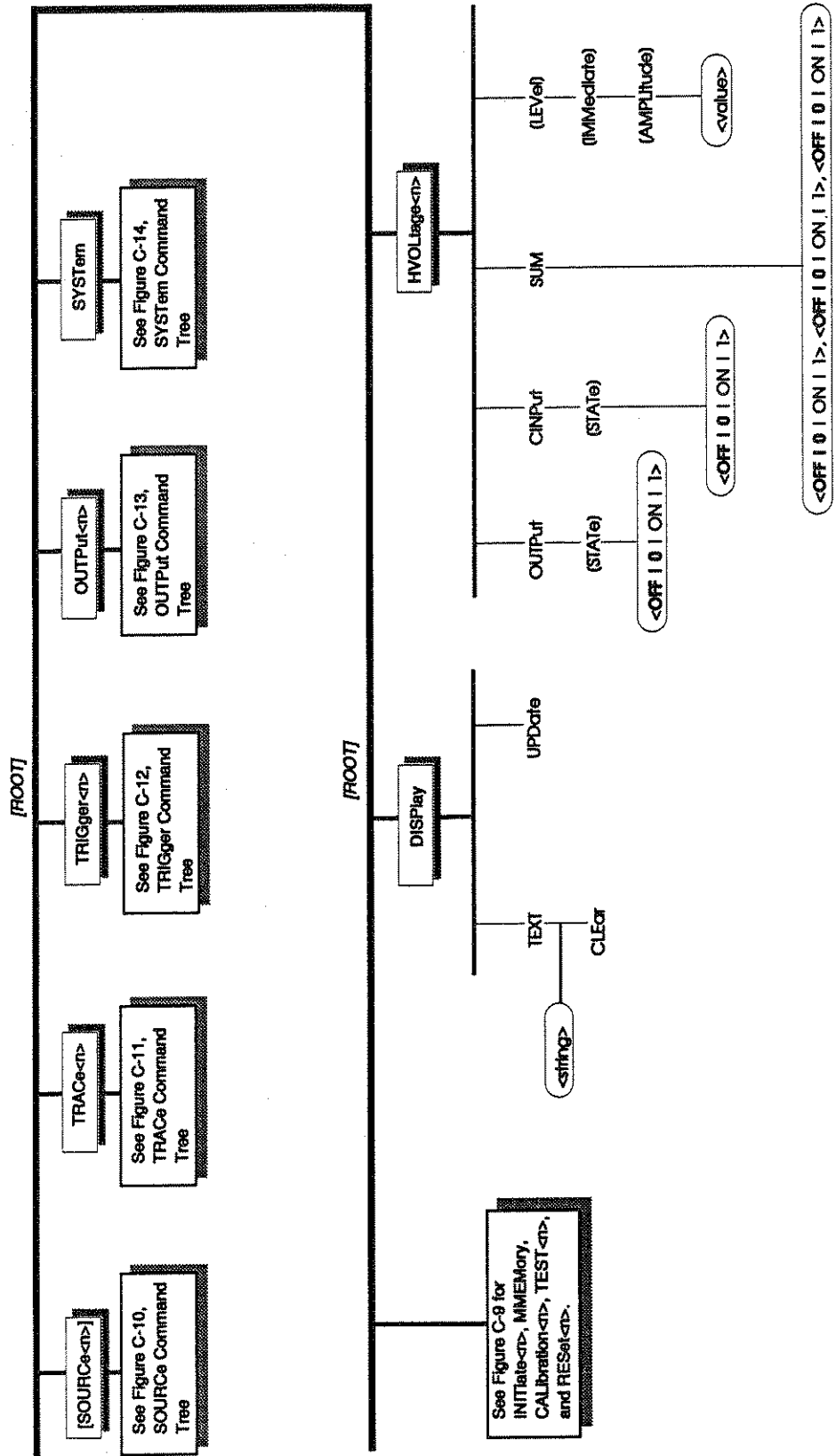

Figure C-15. DISPlay and HVOLtage Subsystems

SCPI CONFORMANCE INFORMATION

This Appendix contains compliance data as required by the SCPI 1992 Specification, Volume 1: Syntax and Style. Specifically, paragraph 4.2.3, Documentation Requirements, specifies the Conformance Information requirements for SCPI products.

Model 295 SCPI Version

The Model 295 50 MHz Arbitrary Waveform Generator has been designed to comply with SCPI Version 1992.0, dated February 1992.

Model 295 SCPI Command Syntax

The SCPI specification, Version 1992.0, defines three type of SCPI commands which may be used in a SCPI product: Confirmed Commands, Approved Commands, and commands which are not part of the SCPI definition.

SCPI Confirmed Commands

Confirmed Commands are those commands which are published in the SCPI 1992 Specification, Volume 2: Command Reference. Refer to Table C-2 for the complete syntax of Model 295 SCPI commands. Model 295 Confirmed Commands will be identified with the notation "Confirmed" in the third column.

SCPI Approved Commands

Approved Commands are those commands which have been approved by the SCPI Consortium, but are not published in the SCPI 1992 Specification. Refer to Table C-2 for the complete syntax of Model 295 SCPI commands. Model 295 Approved Commands will be identified with the notation "Approved" in the third column.

Commands not part of the SCPI Specification

The SCPI Specification does allow products using the SCPI language to have specialized commands included which are outside of the SCPI definition. Refer to Table C-2 for the complete syntax of Model 295 SCPI commands. Any Model 295 commands which are not in the SCPI definition will be identified with the notation "Not SCPI Approved" in the third column.

Incomplete Command Implementation

The SCPI definition specifies each command completely, and if the command keyword is at the *leaf node*, it specifies the parameter data and query responses. In some cases, a SCPI product may not implement all of the choices given in the specification.

For example, when parameter character data is in the form of a list of choices, the product's hardware may not support all of those choices:

```
[SOURce]:FREQuency:MODE <CW | FIXed | SWEep | LIST | SENSE>
```

In this example, a complete list of possible Frequency Modes is given. However, the product's feature set may want to have a settable Frequency Mode in order to set a CW | FIXED frequency, and to enter a Frequency Sweep Mode. The other Modes, LIST and SENSE, may not have any hardware to support them. In this case, the SCPI Syntax Table (see Table C-2) would use footnotes to indicate partial conformance to the SCPI Specification.

Table C-2. Model 295 SCPI Command Syntax

KEYWORD	PARAMETER FORM	NOTES
CALibration<n> [:ALL]? :DATA :AFCorrection :AMPLitude [:GAIN] :OFFSet :AMZero OFFSet [:GAIN] :OFFSet :PAZero :SCMZero :STORe :SQRSymmetry :STATe	<arbitrary block program data> <point>,<frequency>,<gain> <numeric_value> <numeric_value> <numeric_value> <POSitive NEGative>,<numeric_value> <POSitive NEGative>,<numeric_value> <numeric_value> <numeric_value> <numeric_value> <boolean>	Confirmed Confirmed Confirmed Not SCPI Approved Not SCPI Approved Not SCPI Approved Not SCPI Approved Not SCPI Approved Not SCPI Approved Not SCPI Approved Not SCPI Approved Not SCPI Approved Not SCPI Approved Not SCPI Approved Confirmed
INITiate<n> [:IMMEDIATE] :CONTinuous	<Boolean>	Confirmed Confirmed Confirmed
MMEMory :CATalog? :COPY :DELete :INITialize :LOAD :SEquence :SETup :TRACe :STORe :SETup :TRACe	<RAM DISK> <source_name>,<RAM DISK>,<dest_name>,<RAM DISK> <file_name>,<RAM DISK> <RAM DISK> <n>,<sequence_name>,<RAM DISK> <setup_name>,<RAM DISK> <n>,<trace_name>,<RAM DISK> <setup_name>,<RAM DISK> <n>,<trace_name>,<dest_name>,<RAM DISK>	Confirmed Confirmed ¹ Not SCPI Approved Confirmed ^{1,2} Not SCPI Approved Not SCPI Approved Not SCPI Approved Not SCPI Approved Not SCPI Approved Not SCPI Approved Not SCPI Approved Not SCPI Approved
OUTPut<n> :CLOCK :FREQuency :MASTer :SOURce [:STATe] :SOURce :FILTer [:LPASs] [:STATe] :SELect [:STATe] :SUMBus [:STATe] :TRIGger [:STATe] :SOURce	<numeric_value> <INTernal EXTernal> <Boolean> <RASTer SYNThesizer> <Boolean> <ELLiptic BESSel> <Boolean> <Boolean>	Confirmed Not SCPI Approved Not SCPI Approved Not SCPI Approved Not SCPI Approved Not SCPI Approved Confirmed Confirmed Confirmed Not SCPI Approved Confirmed Not SCPI Approved Not SCPI Approved Not SCPI Approved Not SCPI Approved Not SCPI Approved

Table C-2. Model 295 SCPI Command Syntax (Continued)

KEYWORD	PARAMETER FORM	NOTES
RESet<n>		Confirmed
[SOURce<n>]		Confirmed
:AM		Confirmed
[:STATe]	<Boolean>	Confirmed
:MODE	<AM SCM>	Not SCPI Approved
:CLOCK		Not SCPI Approved
:CONFigure	<INPut OUTPut>	Not SCPI Approved
:FREQuency		Confirmed
[:CW FIXed]	<numeric_value>	Confirmed
:MANual	<numeric_value>	Confirmed
:MODE	<CW FIXed SWEep>	Confirmed ²
:RASTer	<numeric_value>	Not SCPI Approved
:START	<numeric_value>	Confirmed
:STOP	<numeric_value>	Confirmed
:FUNction		Confirmed
[:SHAPe]	<shape_name>	Confirmed
:USER	<trace_name>	Not SCPI Approved
:MODE	<FIXed SEQuence>	Confirmed ¹
:GROup	<numeric_value>	Not SCPI Approved
:MARKer		Confirmed
:POSition		Not SCPI Approved
:AOFF	<trace_name>	Not SCPI Approved
:POINt	<trace_name>,<point_index>	Not SCPI Approved
:ZAXis		Not SCPI Approved
:AOFF	<trace_name>	Not SCPI Approved
:POINt	<trace_name>,<point_index>	Not SCPI Approved
:SYNC		Not SCPI Approved
:SOURce	<ZCRoss BBITs>	Not SCPI Approved
[:STATe]	<Boolean>	Not SCPI Approved
:TRIGger		Not SCPI Approved
[:STATe]	<trace_name>,<Boolean>	Not SCPI Approved
:PHASe		Confirmed
[:ADJust]	<numeric_value>	Confirmed
:MODE	<INDEpendent MASTer SLAVe>	Not SCPI Approved
:ROSCillator		Confirmed
:SOURce	<INTErnal EXTErnal BUS>	Confirmed ¹
:SEQuence		Not SCPI Approved
:ADVance	<AUTOMatic TRIGgered>,<list_index>	Not SCPI Approved
:DWELl	<numeric_value>,<list_index>	Not SCPI Approved
:FUNction	<trace_name>,<list_index>	Not SCPI Approved
:LENGth	<numeric_value>	Not SCPI Approved
:TRIGger		Not SCPI Approved
:SENSe	<EDGE LEVel>	Not SCPI Approved
:MODE	<SYNChronous ASYNchronous>	Not SCPI Approved
:SUMBus		Not SCPI Approved
[:STATe]	<Boolean>	Not SCPI Approved
:ATTenuation	<numeric_value>	Not SCPI Approved

Table C-2. Model 295 SCPI Command Syntax (Continued)

KEYWORD	PARAMETER FORM	NOTES
[SOURce] (cont'd) :SWEep :COUNT :DIRection :MODE :SPACing :TIME :VOLTage [:LEVel] [:IMMediate] [:AMPLitude] :OFFSet	<numeric_value> <UP DOWN> <CRESet TRESet HRESet CREVerse TREVerse HREVerse MANual> <LINear LOGarithmic> <numeric_value> <numeric_value> <numeric_value>	Confirmed Confirmed Confirmed Confirmed ¹ Confirmed Confirmed Confirmed Confirmed Confirmed Confirmed
SYSTem :CHECksum? :ERRor? :DATE :KEY :TEST? :REfERENCE :SOURce :TIME :TRIGger [:IMMediate] :LEVel :POLarity :TTL :VERsion? :ZAXis :LEVel :POLarity	<year>,<month>,<day> <numeric value> <INTernal EXTernal> <hour>,<minute>,<second> <numeric_value> <POSitive NEGative> <numeric_value> <POSitive NEGative>	Confirmed Not SCPI Approved Confirmed Confirmed Not SCPI Approved Not SCPI Approved Not SCPI Approved Not SCPI Approved Confirmed Not SCPI Approved Not SCPI Approved Not SCPI Approved Not SCPI Approved Not SCPI Approved Not SCPI Approved Not SCPI Approved
TEST<n> [:ALL]? :RAM?		Confirmed Confirmed ¹ Confirmed ¹
TRACe<n> :ADDRes? :CATalog? :DEFine [:DATA] :LINE :POINt :DELete [:NAME] :ALL :DIRectory? :FREe? :LCONTiguous? :LIMits <trace_name>,<start_index>,<stop_index>	<trace_name>,<trace_name> <numeric_value> <trace_name>,<trace_name> <block> <trace_name>,<point_index1>,<point_value1>, <point_index2>,<point_value2> <trace_name>,<point_index>,<point_value> <trace_name>	Confirmed Not SCPI Approved Confirmed Confirmed Confirmed Confirmed Not SCPI Approved Confirmed Confirmed Confirmed Not SCPI Approved Confirmed Confirmed Not SCPI Approved Confirmed Not SCPI Approved Not SCPI Approved

Table C-2. Model 295 SCPI Command Syntax (Continued)

KEYWORD	PARAMETER FORM	NOTES
TRACe<n> (cont'd) :MODE :POINts :REName :SElect	<CW RASter> <trace_name>,<numeric_value> <trace_name>,<trace_name> <trace_name>	Not SCPI Approved Confirmed Not SCPI Approved Not SCPI Approved
TRIGger<n> :COUNt :GATE [:STATe] [:IMMediate] :POLarity :SOURce [:STARt] :ADVance :TIMer	<numeric_value> <Boolean> <POSitive NEGative> <INTernal BUS EXTernal MASTer INPut0 INPut1 INPut2> <INTernal BUS EXTernal MASTer INPut0 INPut1 INPut2> <numeric_value>	Confirmed Confirmed Not SCPI Approved Not SCPI Approved Confirmed Not SCPI Approved Confirmed ¹ Not SCPI Approved Not SCPI Approved Confirmed
DISPlay TEXT CLEar UPDate	<string>	Confirmed Not SCPI Approved Not SCPI Approved Not SCPI Approved
HVOLTage<n> :OUTPut [:STATe] :CINPut [:STATe] :SUM [:LEVel] [:IMMediate] [:AMPLitude] :RESet :VERSion?	<Boolean> <Boolean> <Boolean>,<Boolean>,<Boolean> <numeric_value>	Not SCPI Approved Not SCPI Approved Not SCPI Approved Not SCPI Approved Not SCPI Approved Not SCPI Approved Not SCPI Approved Not SCPI Approved Not SCPI Approved Not SCPI Approved
STATus :OPERation :CONDition? :ENABle [:EVENTt]? QUESTionable :OPERation :CONDition? :ENABle [:EVENTt]? :PRESet	<numeric_value> <numeric_value>	Confirmed ³ Confirmed ³ Confirmed ³ Confirmed ³ Confirmed ³ Confirmed ³ Confirmed ³ Confirmed ³ Confirmed ³ Confirmed ³

1. Device dependent parameter character data.
2. Incomplete implementation; at least one parameter not supported per SCPI specification.
3. STATus Subsystem commands operate per the specification, but the physical Status Registers are not implemented in the hardware.

RACKSLIDE KIT INSTALLATION INSTRUCTIONS

Refer to Figure D-1 on the following page while following the step-by-step instructions. Table D-1 lists the parts supplied with the rack mounting kit. Reference designators in table D-1 are keyed to the index numbers in figure D-1.

1. Remove cover screws, 2 places per cover. Slide covers back and off the unit.
2. Remove side panel screws, 2 places per side panel. Slide side panels back and off the unit.
3. Remove foot mounting hardware and feet, 4 places.
4. Re-install covers using original hardware. Side panels do not get re-installed.
5. Install rackear/handle (item number 5) and adapter (item number 6) 2 places, using hardware item number 4, 3 places per side.
6. Install rackslide (item number 2 – only inner member is illustrated for clarity) and adapter (item number 1) 2 places, using hardware item number 3, 3 places per side. Note orientation of item number 1. Surface with slots must be up against side of chassis.

Table D-1. Rack Mount Parts List

Ref Des	Description	Orig Mfgr No.	Mfgr	Wtk No.	Qty
1	Bar, Adapter, Rack slide	1400-02-5251	Wvtk	1400-02-5251	2
2	Slide, 20 in. made from 2400-06-0002	2400-99-0002	Wvtk	2400-99-0002	2
3	Screw, 10-32X1,TRS	10-32 X 1 TRS	CMRCL	2800-20-0116	8
4	Screw, 82° F-Head Phillip, 6-32, 3/4 LG Stainless Steel	6C75FXS	WFAST	2800-54-0216	8
5	Handle/Rack Ear	1400-02-5250	Wvtk	1400-02-5250	2
6	Adapter, Handle/Rack Ears	1400-02-5252	Wvtk	1400-02-5252	2
7	Bracket	JPN-SP0440	NL	2400-07-0003	4
8	Nut, Hex, 8-32, Z	8-32 Hex Nut	CMRCL	2800-14-8100	10
9	Washer, Flat, #8	#8 FW	CMRCL	2800-26-8000	10
10	Screw, Pan, CAD I, Cross Recess, 8-32 X 3/8	8-32 X 3/8 Pan	CMRCL	2800-38-8106	10
11	Lockwasher, #8 Split Ring, SS	#8SRLW	CMRCL	2800-42-8000	10

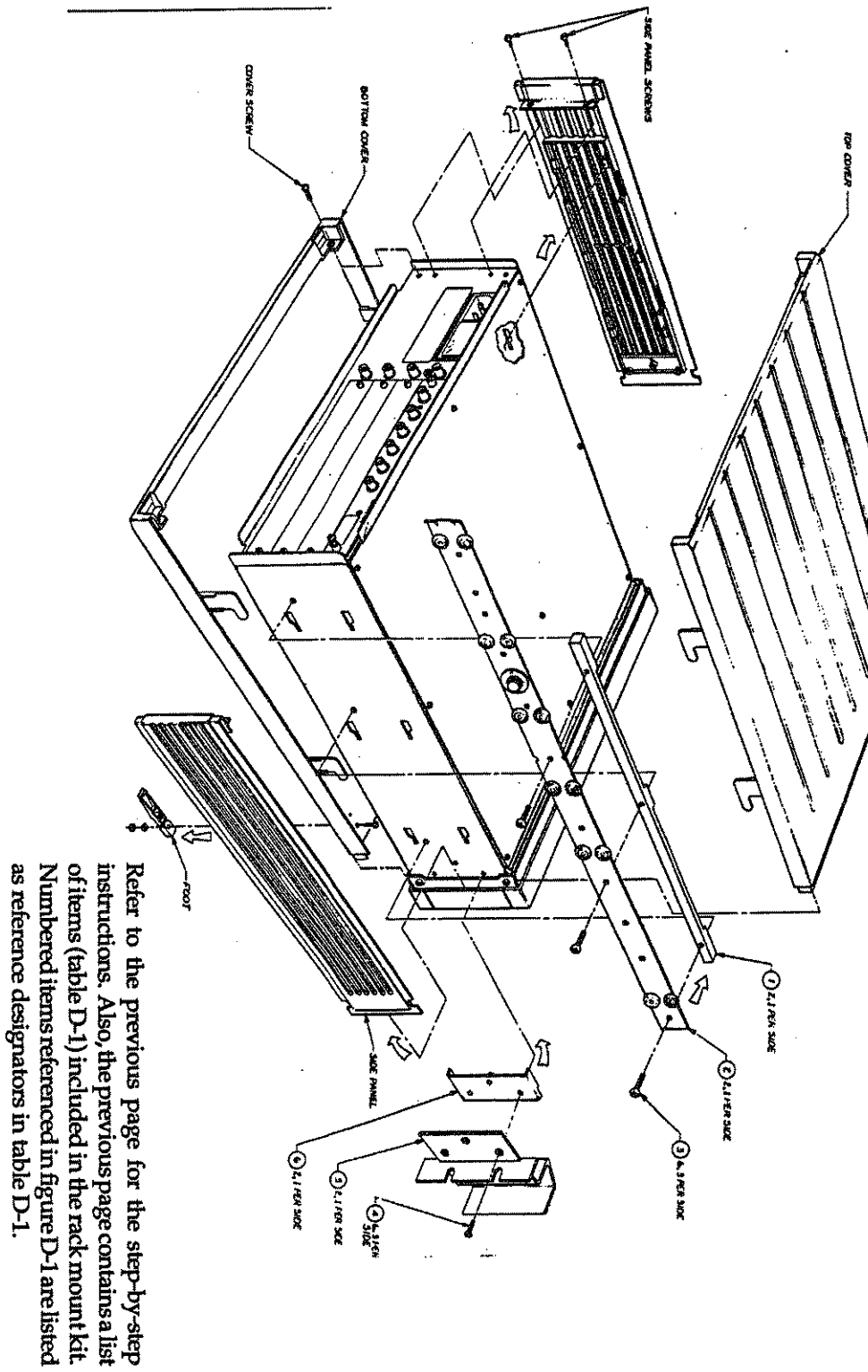

Refer to the previous page for the step-by-step instructions. Also, the previous page contains a list of items (table D-1) included in the rack mount kit. Numbered items referenced in figure D-1 are listed as reference designators in table D-1.

Figure D-1. Model 295 Rackslide Kit

NOTE: Any OK/CANCEL buttons that are normally part of the message that you see on the display have been omitted from the message descriptions given here.

Look for the message of interest under the following categories:

- Waveform Editing Messages
- Waveform Messages
- Sequences Messages
- Save/Restore Setup File Messages
- File Operations Messages
- Backup RAM Messages
- Channel Grouping Messages
- External Connection Messages
- Instrument Messages
- PCX Image Message
- 3V Battery Check Message
- Disk Drive Messages
- Remote Operation Messages
- Self-Test and Calibration Messages
- Internal System Error Messages

Waveform Editing Messages

- Make connections to scope:
 - Channel MAIN OUT and SYNC MARKER
 - Chassis Z AXIS OUT to scope Z axis
- Trigger scope on SYNC OUT
- Set up scope to 0.5V/division and 'X' sec/division

This message appears as part of loading a waveform to be edited. It gives the proper scope setup in order to see the waveform in proper perspective. Failure to set the scope as indicated, especially the 'X' sec/division, results in a waveform exceedingly difficult to edit.

The message box has both BEGIN and CANCEL edit selections. Should you choose to CANCEL, the current output function is not changed.

Waveform memory

There appears to be a problem with waveform memory on the current channel card.

Waveform hardware

There appears to be a problem with the channel card hardware.

Bad waveform size

or

Insufficient waveform memory.**Delete waveforms and try again**

Both of these errors have the same cause. The current channel does not have enough free memory for the waveform you are attempting to load into it. You can delete individual waveforms by using the "Waveforms Management" screen's "Delete" menu.

Block too large to copy

The block of the waveform that you have selected to copy is too big to copy. Model 295 has to make a temporary version of the block, and there is not enough free memory in the instrument currently to support the selected size.

Nothing to paste

Paste command chosen with no data in the paste buffer (no previous cut or copy).

Too many points in paste buffer

You are attempting to insert data from the paste buffer into the waveform in a position such that not all the data fits before the end of the waveform is reached. Either move the insert point closer to the beginning of the waveform, or resize the waveform.

Original waveform cannot be restored after editing

If you perform waveform edit on a waveform that is present only on the channel card (not saved), you cannot recover the original waveform after editing. Model 295 does not keep a backup copy of such waveforms. If the waveform also exists or exists instead as a file in backup RAM or on disk, this problem does not occur (and the message does not appear).

Waveform storage format is invalid

File chosen to load as a waveform is in a format not understood by Model 295. This is probably caused by naming a floppy disk file with a name that appears to the 295 to be a waveform file when it is not.

Waveform Messages

Waveform <name> already exists in channel memory OK to Overwrite?

You have chosen to load a waveform. One by the same name, <name>, is already present in the current channel's memory. This message gives you a chance to cancel the load so that you can copy this waveform to a permanent location, should you so desire.

Load Waveform Waveform <name> not found on <Source>

During restoration of a stored setup, the instrument could not find a waveform file 'X' where it was expected. <Source> is the source where the waveform was expected: disk drive or backup RAM. The file may have been deleted or renamed. Since a required waveform could not be found, the channel is set to the default, standard function, SINE.

No Waveform or Sequence Active on channel <n>

On the "Waveforms Management" main screen, the "Active" menu choice is only available when the current channel is running a user-defined waveform or a sequence. If that is not the case, this message is displayed.

Delete all Waveforms Delete all waveforms in channel <n> memory?

On the "Channel Waveform Memory" screen, you have picked the "DELETE ALL" button. This message gives you the chance to cancel deleting all waveforms from the memory of channel <n>. Once deleted, they must be recreated or reloaded from non-volatile memory (RAM or DISK).

Sequences Messages

The channel does not have enough memory to load the sequence.

Delete waveforms and try again.

While attempting to load a sequence, Model 295 has determined that the channel card does not have enough free waveform memory to load all the waveforms required for the sequence.

Rather than arbitrarily deleting waveforms to make room, the instrument cancels the sequence load and lets you decide which waveforms to delete to free up enough room. You can use the "Delete" menu choice on the Waveforms screen to select individual waveforms to be deleted.

OVERWRITE SEQUENCE <name>

Are you sure?

After editing, you have selected to save a sequence to a place in which a sequence of the same name already exists. This message gives you a chance to cancel the save so that the other sequence will not be lost.

Sequence Load

The requested sequence contains the waveform <name> which was not found on <Source>

While loading the sequence, Model 295 failed to find waveform <name> where it was expected. <Source> is either Backup RAM or Disk. The channel is set to the default SINE function.

Load Sequence

Sequence <name> not found on <Source>

While restoring a saved setup, Model 295 could not find the sequence file called for by the saved setup. The sequence name is <name>, and <Source> is where it was expected: disk drive or backup RAM. You may have accidentally deleted the sequence file. The channel is set to SINE function since the sequence is unavailable. Restoration of the stored setup is terminated.

WAIT FOR START TRIGGER SIGNAL or START SEQUENCE NOW?

Whenever a sequence is loaded for execution on a channel, this dialog is presented to let you decide how to start the sequence. If you choose START NOW, the sequence's first waveform begins immediate playback. If you choose WAIT, the first value of the first waveform in the sequence is output, and further playback waits for a trigger signal. That trigger is whatever trigger is currently set for the channel's start trigger. This defaults to the channel's internal trigger rate generator, 1 kHz frequency until changed.

No Sequence Active on channel <n>

On the "Sequences Management" main screen, the "Active" menu choice is only available when a sequence is actually running on the current channel. Otherwise, this message is displayed when the "Active" menu selection is made.

Sequence Save

Waveform <name> not found

During the save of a Sequence to Battery-Backed RAM or DISK, the Waveform segment named <name> could not be found. The SAVE is not completed. This error is most likely to occur when doing a Sequence Copy with the "also copy waveforms" box selected. It means that the sequence file was found for copying, but a waveform that is part of the sequence was not present at the Source location and could not be automatically copied. To clear up the problem, manually locate the waveform file and copy it to either the Sequence Source or Destination location.

Save/Restore Setup File Messages

Invalid Saved Setup file

Attempted to restore a file that was not a stored setup.

Saved Setup file: unsupported version

The chosen setup file is in a format incompatible with the current Model 295 firmware.

Error restoring saved setup

An error occurred reading the contents of a saved setup file. The restoration is aborted, but channel settings may be partially altered.

Setup Save: Waveform or Sequence running on channel <n> exists only in channel memory (not saved). Setup will not be restorable once Instrument is turned off. See Help: Instrument Stored Settings. Model 295 is preparing to perform a SETUP:SAVE. It detects that on one or more channels the current function is a user-defined waveform that exists only in channel card memory. It was not loaded from Disk or Battery-Backed RAM, but instead selected from "Current Channel".

When power is removed, all waveforms in channel card memory are lost. If you attempt to recall this saved setup after power is cycled, it will fail because the waveform will be gone. Until you cycle power, recall will work just fine.

This message gives you a chance to cancel the save if desired.

Ways to resolve the problem:

1. Edit the waveform on the channel, save it to disk or RAM, load it back up from there, then do the Setup Save.
2. Before attempting to load the setup after power-cycle, create a waveform with the same name as the one that disappeared.

Setup Save: Waveform or Sequence running on channel <n> was loaded from a different source than where the setup is being saved to. Either copy the function to the same destination after Setup Save is done, or cancel the save.

You are saving a setup to disk or backup-RAM, but on channel <n>, the waveform running was loaded from another source. When a setup is restored, it assumes that all waveforms or sequences are to be loaded from the same source on which the setup file itself resides.

Unless you correct this possible problem, the setup will not be restorable. As the message says, either cancel the save, or after it completes make sure to copy running sequences or waveforms to the same location, if they aren't already there.

Waveform <name>, on Channel <n> has "X" markers in it, more than the 15 that setup save allows. Setup will not be restorable as is. See Help: Instrument Stored Settings.

During the processing of a Setup Save, the model 295 detects that waveform <name> running on channel <n> has been edited with the Active Waveform Parameters screen to set some Markers. Saved Setups currently support only 15 Markers saved, but you have set more ("X"). Only the first 15 markers get saved and later restored. The remainder will be lost.

If you want all markers saved, there is a way. If you first save the waveform with Waveform Copy from the channel card to Battery-Backed RAM or DISK, the save will be done in binary format which will include all markers. Load this waveform back to the channel memory and then do the Setup Save. You will still get this warning message, but at Restore time the binary waveform will contain all of the markers which the Setup Save couldn't store.

Setup Recall not possible with no channels installed.

Model 295 will not execute a "Stored Setups Recall" menu choice if no channels are installed in the instrument. The request is ignored.

Invalid Saved Setup

The file chosen does not appear to be a valid setup file. This is probably due to giving an arbitrary disk file a name that appears to be that of a stored setup. Model 295 checks the format of a chosen setup file, and will reject anything suspicious.

Setup Save: No channels installed. Nothing to save.

Model 295 will not perform a "Stored Setups Save" menu choice if no channels are installed in the instrument. The request is ignored; no file is created.

Setup <name> already exists.

OK to overwrite?

A setup with the same name as the one you are about to store, <name>, already exists on the chosen destination. You now have a chance to cancel the store, which leaves the existing setup alone, or choose OK, which erases the old setup and stores a new one.

Stored Setup Copy:

Error reading Sequence <name> from <Source>. "File not Present"

You are performing a Stored Setups Copy menu choice, and have checked the "also copy waveforms" box. One of the channels is running the Sequence <name>, which was loaded from the <Source> (Battery-Backed RAM or DISK). Setup Store couldn't find this Sequence file to copy it. "File not Present" is a typical problem-specific error message included with this screen.

Sequence <name> has been edited since it was loaded from <Source>. Update stored copy to match running version?

During Stored Setups Save, the model 295 detects that you have used the Active Sequence Parameters screen to change Sequence <name>, which was loaded from <Source>, Battery-Backed RAM or DISK. Unless you update the stored version of the Sequence to match the version currently running on the channel, the Stored Setup will not restore the unit to match the current configuration. This prompt asks you if the model 295 should automatically perform an update of the Sequence file as it stores the setup.

File Operations Messages

**DELETE FILE: <extension>,<name> on <Source>
OK to delete it?**

On the "Utility: Files" screen, after you pick a file name and select the DELETE button, this message appears. It gives you a final chance to cancel the delete. <name> is the file name, <extension> is the file type (waveform, sequence. . .), and <Source> is where it resides: DISK or Backup RAM.

**Format Disk
All data on disk will be lost.
Are you sure?**

On the "Utility: Files" screen, this box results from making the menu choice "Disk Format". You get a chance to cancel the format. Once you select "Format", all data on the currently installed floppy disk is permanently lost. The format process takes around 3 minutes.

**Format Results
Disk type: X
Bytes avail: Y
Bytes bad: D**

Once floppy disk formatting is complete, this message reports the results of the format. X is either 720 KB or 1.44 MB. Y is the amount of space available for user files. Z is the amount of space that had to be mapped as unavailable because no reliable formatting could be applied to it.

**COPY FILE: <extension>,<name> on <Source>
OK to delete it?**

On the "Utility: Files" screen, after you pick a file name and select the COPY button, this message appears. The selected file <name>, <extension> file type (waveform, sequence. . .), and <Source> (DISK or Backup RAM) already exists, although it is the target for a copy file. This message gives you a chance to cancel over-writing the target file.

Cannot copy file to same name and destination as the source.

On the "Utility: Files" screen, you chose a file to copy, and then entered the same name for the new file, and placed it in the same destination (Battery-Backed RAM or DISK) and the source file. Change the name or destination.

Backup RAM Messages

Not enough storage memory

The file you are attempting to create takes more memory than is left in backup RAM. Request denied.

Bad name

The file name given is illegal.

Name already exists in storage

A file name exists in backup RAM that has the same type and name as that just entered.

Channel Grouping Messages

Current channel <n> is a slave.

Frequency change affects master channel Y.

This message results when you change the frequency field on the "Channel Setup" screen, and the current channel has been set as a slave channel. The slave setting was selected at some earlier time on the channel grouping screen (a menu choice on the "Instrument Setup" screen).

The intent of this warning message is to let you know that if you continue with this frequency change, not only is the current channel's frequency changed, but also that of the master and all other slave channels.

After selecting a channel on the Channel Setup screen, you are given this warning only once. You are not warned for every frequency change.

Channel is part of a group.

Clock cannot be changed here.

Adjust channel grouping?

This appears when you attempt to select the "Clock BNC" menu choice on the "Channel Setup" screen. The channel has been put in a group, via the channel grouping menu choice on the Instrument screen.

If you answer yes to this box, the channel grouping screen is automatically brought up, allowing you to remove the channel from the group. Answering no just cancels the menu choice.

Channel grouping: Grouping not possible with less than 2 channels installed

If only one channel is installed in Model 295, there is no meaning to channel grouping. The menu choice is denied, with this message informing you why.

Slave channels require a Master channel.

After selecting DONE on the channel grouping screen, the instrument checked your settings and found that you set one or more channels to be slaves without also selecting a master channel.

This is an unworkable configuration, so the offending channels are set to Independent operation.

Channel 1 must be part of the group

Due to hardware constraints, any channel grouping combination must include Channel 1. It does not have to be the master—only be present in the group as a Master or Slave.

All channels are reset to Independent operation.

Only master or slave channels can be phase locked.

Lock setting ignored.

After you selected DONE on the channel grouping screen, the instrument found that you had checked the Phase Lock box on a channel that is set to Independent (not part of the group). Only grouped channels can be phase locked.

The request to set phase locking for the independent channel(s) was ignored, but the rest of the group settings were retained (if legal).

External Connection Messages

**Internal clock output selected:
Make sure no external clock is
connected to clock BNC or select CANCEL**

On the "Clock BNC" dialog, you have chosen to make the Clock BNC an output. The internal channel clock will be routed to the BNC. If you have an external signal applied to the BNC, this selection can damage the external source, Model 295, or both. This box gives you a final chance to cancel the selection.

**Internal Reference Selected:
Reference will be output on REF IN/OUT connector.
Make sure no external reference is connected or select CANCEL**

On the "10 MHz REFERENCE" dialog, you have chosen the "Output" radio button. If you select "DONE", the internal signal will be routed to the rear panel REF IN/OUT connector. If an external input signal is also present, damage to Model 295 or the external source could occur.

The "10 MHz REFERENCE" dialog is brought up on the "Instrument" main screen by selecting the "10 MHz Reference" menu choice.

No External 10 MHz reference

The current setting of the 10 MHz Reference is as an input. A valid external signal was present, and Model 295 switched itself to use it as the reference.

Now, however, that signal has been lost. Model 295 automatically switches back to its internal reference, but also gives this warning.

If a menu is being displayed when the external reference is lost, the warning message does not immediately appear. It shows up as soon as the menu is gone.

Instrument Messages

Reset Instrument:
All channels will be set to default configuration
Are you sure?

You have chosen on the Instrument screen the menu choice "Reset Full Instrument". As the message says, all channels will be set to the configuration in effect upon power-on. This message gives you a chance to cancel the operation.

Reset channel <n>:
Channel will be set to default configuration.
Are you sure?

You have chosen on the Instrument screen the menu choice "Reset Current Channel". The current channel (only) will be set to the configuration in effect upon power-on. This message gives you a chance to cancel the operation. Waveforms in channel memory are not affected.

Reset Battery-Backed RAM:
All waveforms, sequences and setups will be deleted from backup RAM, and all system settings will be reset to default values.
Are you sure?

You have chosen on the Instrument screen the menu choice "Reset Backup RAM". The listed items will be permanently lost unless you pick CANCEL on this message.

Execution error
You are attempting to set channel card hardware to an illegal configuration. Additional lines in the message box describe the problem in more detail.

Settings conflict
A channel setting that you are altering would, if completed, conflict with some other parameter already in effect on the channel. Additional lines in the message box describe what the conflict is.

Data out of range
Channel Error
You have attempted to set channel card hardware to a value outside of limits supported by the card.

High Voltage Option not installed.

On the Instruments screen, you chose the Options: High Voltage menu item. The High Voltage Option is not currently installed in the instrument, so the high voltage option screen is not available.

PCX Image Message

PCX Image View Image is too large

You have selected a PCX file from the floppy diskette that is larger than 320 horizontal or 200 vertical pixels in size. Model 295 cannot display such images.

3V Battery Check Message

3V Battery Check

FAIL

Level is below 2.7V

When Model 295 is first turned on, it performs a check of the internal battery that preserves the contents of backup RAM while the instrument is off. This backup RAM is the "Battery-Backed RAM" that is a selection for file operations. It is also where user preferences such as LCD viewing angle are maintained. If the voltage is below 2.7 volts, RAM contents may not be retained when power is removed.

This warning message tells you it is time to replace the lithium battery inside the unit.

This battery has no connection with instrument calibration data.

Disk Drive Messages

Disk directory full

Couldn't create file on disk — disk has no more room for file names.

File not found

Specified file not found on floppy disk. This message should not normally be encountered.

File already exists

Specified file already exists on the floppy disk. This message can result from copies or saves to the disk where you enter a name rather than pick from a list.

File is read-only

Attempted to modify or delete a read-only file on floppy. You need to take the floppy disk to an MS-DOS machine and remove the write protection from the file.

Improper disk file name

File name entered is not a legitimate DOS name.

Cannot read or write volume or directory name

During formatting, unable to properly access track-0 on floppy.

Disk has bad track

Read or write has problem with a bad or improperly formatted track.

No disk in drive

or:

Probable unformatted disk

or:

Diskette not in DOS format

or:

Disk not present or not DOS format

Attempt to read from empty disk drive, installed disk is not formatted, or the disk present has a non-DOS format.

Insufficient memory to perform disk operation

Internal error. Not enough system memory remaining to properly buffer data to or from the floppy disk.

Disk drive not installed

If the disk drive option has not been purchased, disk operations are not available. This message so informs.

Not enough room on disk

Attempted write operation needs more space than remains free on the current floppy disk.

Cannot write to existing file

Attempted to delete or write to a file that was write-protected.

Unexpected end of disk file

The file being read from the floppy is listed in the disk directory as having a particular size. However, when Model 295 actually read the file, it encountered the end of the file earlier than this expected size. Results of the operation are undefined. The disk is probably corrupted and should be reformatted (after copying any importantly files to another disk).

Disk controller failure

Hardware that supports the floppy disk drive is not functioning properly.

Disk read error

or

Disk read incomplete

or

Disk read data loss

Unrecoverable error when reading data from floppy disk. This could be a file problem, or even the catalog section of the disk.

Disk is write protected

A write operation to a floppy failed because the write protect hole in the floppy has been opened, making disk writes impossible.

Disk cannot be formatted: write protected

Attempt to format a write protected disk. Not possible.

Disk write error

or

Disk write data loss

Unrecoverable error writing data to floppy disk. Writing to any portion of the floppy may generate this error.

Format not completed

Diskette format aborted because of some problem that has already been reported in another message box.

Disk read status

Disk drive hardware reports that there has been a controller failure during disk operations.

Remote Operation Messages

Value cannot be changed while under remote control

Attempt made to change a value from the front panel, while Model 295 is under remote control. You may view most screens while in remote, but parameters cannot be altered. Go to the "Utility: Remote Configure" screen and select the "GO TO LOCAL" button to re-enable working with the instrument via the front panel.

Cannot change remote source while in remote

On the "Utility: Remote Configure" screen, you have attempted to change the remote source field while the instrument is under remote control. You must select "GO TO LOCAL" first.

Self-Test and Calibration Messages

Must successfully perform auto calibration before manual calibration

The Test/Cal, manual calibration portion of the Instrument screen cannot be entered if self calibration has never been performed or has failed.

Calibration data appears to be invalid.

Store defaults?

This message should appear only after channel card repair that causes on-board calibration data to become invalid. Saying OK to this prompt allows Model 295 to install on the channel card some default, fairly accurate values. Self calibration and manual calibration should then be performed.

Cal settings have changed.

Proceed without saving?

Manual calibration values for the current channel have been changed, but the results not yet permanently stored with the "Store Calibration" button. If the manual calibration screen is left, or the channel changed, without first saving altered calibration values, the changes will be lost.

This message gives a chance to remain on the current channel / manual calibration screen and do that store.

Calibration Result chan X

Hex: Y

Decimal: Z

After a self-calibration is completed, this message box reports to you the results. A value of 0 indicates proper self-calibration. Any non-zero value can be used by technicians to diagnose channel card hardware failures. The results are reported in both hexadecimal (Y) and decimal (Z) formats.

Self-Test Result chan X

Hex: Y

Decimal: Z

After a self-test is completed, this message box reports to you the results. A value of 0 indicates proper self-test. Any other value can be used by technicians to diagnose channel card hardware failures. The results are reported in both hexadecimal (Y) and decimal (Z) formats.

Internal System Error Messages

If any of these are seen, contact Wavetek customer service. It would be of help if you can provide a sequence of steps that can duplicate the error message.

Insufficient system memory available

Failure in internal communications

Waveform initialize problem

Waveseq utility

Waveform not found

Sequence not found

Waveform system memory problem

Waveform already exists

Seq util

Set func

Def trace

Trace add

Help access failure

Invalid help data

Invalid help selection

Feature not yet implemented

Edit setup/recall

Too many disk files opened

Name not found in Battery-Backed RAM

Unknown Backup RAM file type

1
2
3
4
5
6
7
8
9
10
11
12
13
14
15
16
17
18
19
20
21
22
23
24
25
26
27
28
29
30
31
32
33
34
35
36
37
38
39
40
41
42
43
44
45
46
47
48
49
50
51
52
53
54
55
56
57
58
59
60
61
62
63
64
65
66
67
68
69
70
71
72
73
74
75
76
77
78
79
80
81
82
83
84
85
86
87
88
89
90
91
92
93
94
95
96
97
98
99
100

F.1 INTRODUCTION

The Digital Storage Oscilloscope (DSO) Upload (Option 005) controls the transfer of waveforms between a digital storage oscilloscope and the Model 295 by means of the General Purpose Interface Bus. The Model 295 receives the waveform as a binary data transfer. The DSO Option, contained on a single 3-1/2 inch diskette, consists of the DSO program (*DSO.295*) and a set of DSO text driver files (*xxx.DSO*).

System Requirements To run the DSO Upload option your Model 295 must contain:

Firmware version V2.0 or later,
Option 002 (3-1/2 inch diskette drive).

Load the program through the Model 295 INSTRUMENT/OPTION screen, and then load the matching ".dso" driver. Refer to paragraph F.2. The DSO option cannot be controlled via SCPI commands.

The DSO Upload diskette at this time supports the following Digital Storage Oscilloscopes:

Gould	4060 Series and 4090 Series
Hewlett Packard	HP 54602
Kikusui	COM7200A, COM7201A, COM7100A, COM7101A, COM7060A, COM7061A
LeCroy	9420/24/50 Series
Nicolet System	400 and 500
Philips	PM3382-PM3385, PM3392-PM3394
Tektronix	11402 and 2430
Tektronix	TDS 420,460, 520, 540, 620, 640 Series
Tektronix	TDS 420,460, 520, 540, 620, 640 Series
Yokogawa	Model DL1200
Yokogawa	Model DL3100B Series

Check your diskette for an up-to-date listing of DSO Driver files.

Paragraph F.3 describes how to upload the waveform from the DSO to the Model 295.

Creating Your Own Drivers

Paragraph F.4 provides the basic information needed to create a DSO driver file for DSOs not currently covered. You can create a DSO driver file using any text editor, *Brief* etc., or word processor that saves ASCII files. Consult the DSO manual for your DSO for the correct waveform uploading commands.

F.2 INSTALLING THE DSO UPLOAD OPTION

The following describes Model 295 DSO Upload Program installation. This section assumes an understanding of the Model 295 mouse and the front panel keys. For a refresher, refer to section 3, *Introduction To the Model 295*,

in this manual.

1. Connect the Model 295 to its primary power source. See section 2, *Initial Turn On*.
2. Turn ON the Model 295 by pressing the POWER switch.
3. Press the INSTRUMENT key on the front panel, and select OPTIONS; see figure F-1.

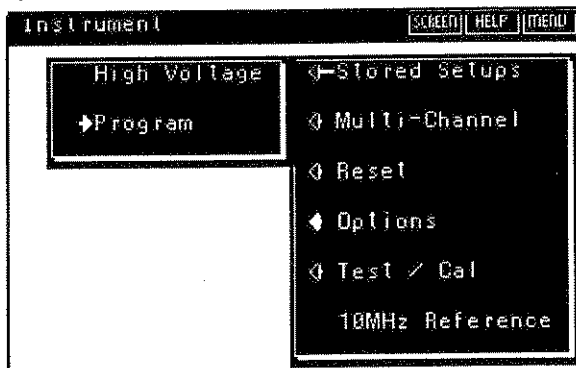

Figure F-1. Instrument/Options Screen

4. The screen displays the User Programs Catalog; see figure F-2.

Note

The Model 295 displays the DSO Upload Program screen if the program is already loaded.

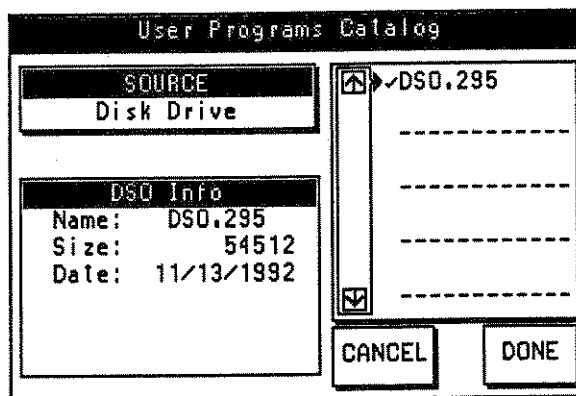

Figure F-2. User Programs Catalog

Select "DSO.295", the DSO Upload program. A check mark (✓) next to "DSO.295" indicates a selected file.

Selecting DONE loads "DSO.295".

5. Once the DSO Upload Program screen appears (figure F-3) set up the Source (DSO) and Destination (Model 295). Also use this screen to upload a DSO waveform.

Source chooses the DSO driver and selects the DSO waveform source. Destination selects the Model 295 channel number and names the waveform.

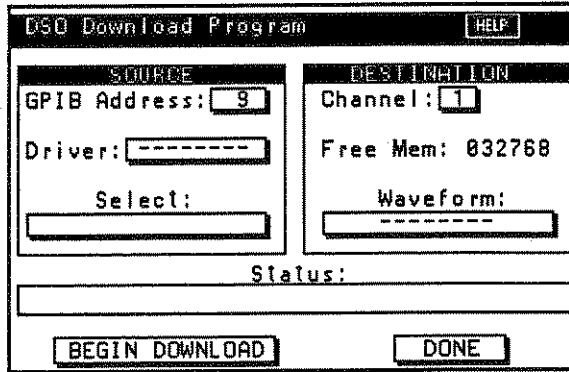

Figure F-3. DSO Upload Program

- 5a. Load a DSO Driver Select DRIVER from the Source block. The DSO Files Catalog, figure F-4, screen appears. An error message appears when you select Begin Upload but failed to select a driver.

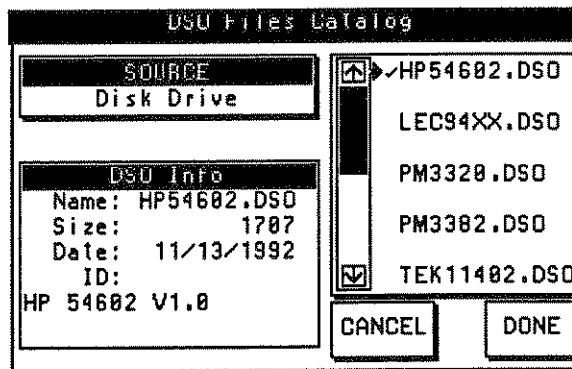

Figure F-4. DSO Selected

From the "List" select the .DSO driver file that matches your DSO. Paragraph F.5 lists the current DSO driver files on the option diskette. If your DSO is not listed, refer to paragraph F.5 which explains how to create new DSO files.

After selecting the driver file (check mark next to the file name), select DONE to load the file DONE. The screen returns to "DSO Upload Program".

Source Select This field allows you to define what DSO source supplies the waveform. Part of the driver file sends unit specific commands to the DSO.

Choose the desired DSO source from the list; see figure F-5.

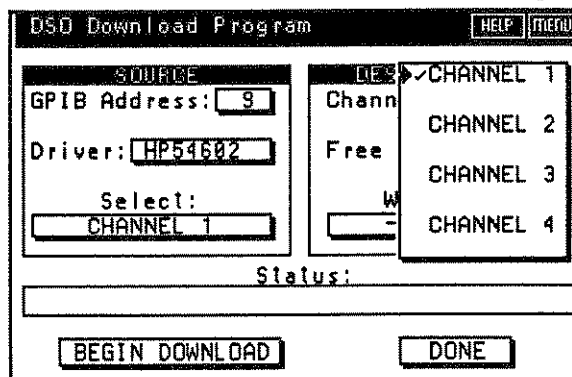

Figure F-5. Source/ Select

GPIB Address This field sets the Model 295 GPIB address to match the DSO's GPIB address. Refer to your DSO manual for information on how to verify or set the DSO's GPIB address.

- 5b. Destination block, see figure F-8, defines the destination Arb Channel for the waveform and names the waveform.

Channel Selects which Arb Channel the DSO will upload the waveform into. Select this field and select the channel number. Only installed Arb Channels will be displayed. If the Model 295 contains one Arb Channel, a list does not appear.

Figure F-8. Destination Block

Waveform Select Waveform to give a name to the uploaded waveform; see figure F-6. An error message appears if you fail to name the waveform before selecting "BEGIN UPLOAD."

Figure F-6. Waveform Name

F.3 SETUP AND UPLOADING - DSO OPTION

F.3.1 Uploading Waveforms

To upload a waveform from the scope:

1. Acquire the waveform in one of the DSO channels.
2. Connect the GPIB cable from the Model 295 to the scope. See figure F-7.

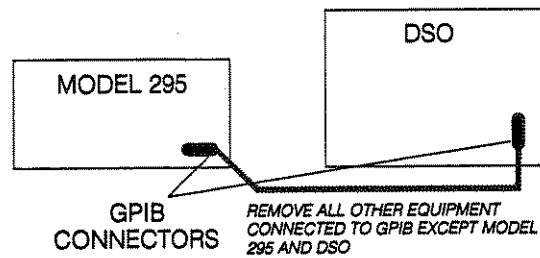

Figure F-7. Model 295 - DSO Interconnection

Disconnect all other equipment from the GPIB bus while uploading from the DSO.

3. Load the DSO Upload program; paragraph F.2 steps 1 through 4.
4. Set up the DSO Upload; paragraph F.2 step 5.
5. Select BEGIN UPLOAD from the DSO Upload screen figure F-8.

DSO Download Program

HELP MENU

SOURCE	DESTINATION
GPIB Address: 9	Channel: 1
Driver: HP54602	Free Mem: 832768
Select: CHANNEL 1	Waveform: CD.wfm
Status:	

BEGIN DOWNLOAD DONE

Figure F-8. DSO Upload

F.3.2 Ending The Program

Selecting DONE from the DSO Upload Program screen, figure F-8, leaves the GPIB set up to for DSO upload and leaves some memory allocated. To free up memory and the GPIB, select END PROGRAM via the DSO Upload Program screen MENU "button"; see figure F-9.

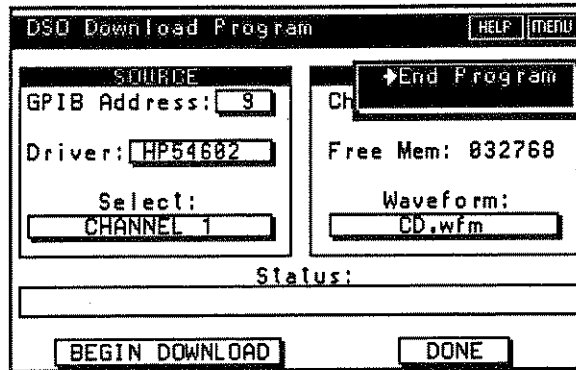

Figure F-9. End Program Screen

F.4 DSO DRIVER FILES

This option diskette also contains DSO Driver files. Table F-1 provides a list of some of the DSO's this option currently supports. Each file contains the commands necessary to set up and transfer waveforms between the DSO and the Model 295.

Table F-1. DSO Drivers

Digital Storage Oscilloscope	File Name
GoULD 4060 Series	GLD4060.DSO
GoULD 4090 Series	GLD4090.DSO
Hewlett Packard HP 54602	HP54602.DSO
Kikusui COM7200A, COM7201A, COM7100A, COM7101A, COM7060A, COM7061A	KIK7XXX.DSO
LeCroy 9420/24/50 Series	LEC94XX.DSO
Nicolet System 400 and 500	NICOLET.DSO
Philips PM3382-PM3385, PM3392-PM3394	PM3382.DSO
Tektronix 11402	TEK11402.DSO
Tektronix 2430	TEK2430.DSO
Tektronix TDS 420,460, 520, 540, 620, 640 Series	TEKTDS.DSO ^{Note1}
Tektronix TDS 420,460, 520, 540, 620, 640 Series	TEKTDSLO.DSO ^{Note2}
Yokogawa Model DL1200	YOK1200.DSO
Yokogawa Model DL3100B Series	YOK3100B.DSO ^{Note3}

^{Note1} TEK TDS driver supports the "hi" resolution -> 16 bit transfers for all waveforms.

^{Note2} TEKTDSLO driver supports the "low" resolution -> 8-bit transfers for all waveforms. The driver performs high resolution 16-bit transfers of waveform data, regardless of the acquisition mode. The resolution for waveforms acquired in Sample, Envelope, or peak-detect modes is 8-bits; 16 bits for Average and High Resolution modes. The uploaded waveform will be scaled to 12 bits.

^{Note3} LEC94XX driver will perform high resolution 16-bit transfers of waveform data. The uploaded waveform will be scaled to 12-bits. Choose the appropriate source selection.

There are several choices for each memory. Try the "All pts" first. If the waveform will not fit, try a selection for fewer number of points.

F.5 CREATING DSO DRIVERS

This paragraph supplies the general information for creating DSO driver

files for digital storage oscilloscopes not currently on the DSO Program diskette. Paragraph F.6 contains four examples of DSO driver files.

To create a new DSO driver file,

First read General Format,

Second, check the DSO's manual for binary waveform upload commands,

Third, write the driver file using an ASCII text editor and store the file on the DSO Program diskette,

Finally, load and run the driver file via the DSO Upload Program's Driver field.

General Format

A DSO driver consists of four description blocks: [id], [setup n], [select n], and [format]. These block can be used in the file in any order. Each file must include [id] and [format] description blocks. There may be a maximum of two [setup n] blocks, and a maximum of twenty [select n] blocks. Also, the file must include at least one of the [setup] or [select] blocks.

```
[id]
[setup 1]                (optional)
[select 1]...[select 20] (optional)
[setup 2]                (optional)
[format]
```

(id)

The id string contains the DSO make and model of the DSO.

```
version = number
id = string                maximum 15 characters
make = string              not used by the Model 295
model = string              not used by the Model 295
```

(setup 1)

For a list of these optional setup commands, see note 1 - Commands.

(select 1) ... (select 20)

Selection blocks create lists of DSO channels to be displayed on the Model 295 screen. Making a selection sends corresponding commands to the DSO. Each Select block must contain at least one display message and a list of one or more commands.

```
display = string           Maximum of 15 characters commands. If the
                           selection is made, the commands listed are ex-
                           ecuted (see note 1)
```

(setup 2)

After sending any Select strings are sent and their subsequent commands executed, then any commands listed in this setup description block are

executed (see note 1).

(format)

The Format block defines the format of the data received by the Model 295. If an item is left out, the default is used. See note 2.

The default is listed first.

size = 1 or 2	number of bytes per data point 1 or 2
order = MSB or LSB	MSB = msb 1st, LSB = lsb 1st
dsize = n	8, 12, or 16 bit data
dsign = n	0 = not signed, 1 = signed 2's complement data
count_type = 1 to 5	see note3
count_size = n	see note3
format = see note2	

Note 1

Commands

The Model 295 will only execute commands after the "Begin Download" button on the display has been selected. Model 295 executes commands in the following order:

- Commands in the first [setup] block;
- Commands in the selected [select] block;
- Commands in the second [setup] block;

After all commands are executed, the Model 295 attempts to read the DSO data in the format specified in the [format] block. At present, there are only three commands:

send = string	The "send" command sends the specified string to the DSO (maximum string size is 256 characters).
	Any ASCII character may be sent as well as: \r for carriage return, \n for line feed. To send a \ character use \\.
timeout = number	Set the GPIB handshake timeout.
count_size = number	The count_size command is only valid when the count_type in the format block is set to 1. See the count_type description in note 3.

Note 2

Format

The format string is a list of specified data elements which are expected to be received from the DSO in the order listed. All bytes sent from the DSO must be accounted for. The acceptable data elements are:

<skip = n>	skip n number of bytes
<skipuntil = "string">	skip until string encountered
<"string">	read in specific string of characters
<count>	defined by count_type and count_size, see note3
<data>	data bytes themselves

Note3

count_type

The count_type parameter determines the type of data found in the <count> field. There are five count_types:

- 1 There is no <count> field, and the count is fixed. The expected number of data bytes to be received is specified by the count_size parameter.
- 2 <count>, a binary number, represents the number of data elements in the <data> field. The number of bytes in <count> is specified by count_size (should be 1 or 2). If count_size = 2, then the order parameter specifies the msb position. The number of bytes in the transfer are calculated as <count> * size.
- 3 <count> is a binary number (NUM) which represents the number of data bytes in the <data> field. To find the number of data points in the waveform by calculating:

$$(NUM)/size$$

The number of bytes in NUM is specified by count_size parameter (should be 1 or 2). If count_size = 2, then the order parameter specifies the msb position.

- 4 <count>, a binary number (NUM), represents the number of bytes remaining in the transfer. To find the number of data points in the waveform, the calculation is:

$$(NUM - \text{any } \langle \text{skip} = n \rangle \text{ fields between } \langle \text{count} \rangle \text{ and } \langle \text{end} \rangle) / \text{size}$$

The number of bytes in NUM is specified by count_size parameter (should be 1 or 2). If count_size = 2, then the order parameter specifies the msb position.

- 5 <count> is specified in the 488.2 Definite Length Arbitrary Block Response Format. <count> is specified in a series of bytes as follows:
Signifies the start of the count field.
numdigs An ASCII digit specifies how many digits in the count
dig1 ... digN The actual digits for the count, in ASCII format

Example

#3256 means count = 256.

The derived count number (example = 256) represents the number of bytes "remaining in the transfer". See count_type #4 for a description of the relationship between: "remaining bytes in transfer" and "number of points in waveform."

DSO DRIVER EXAMPLES

For examples of DSO Drivers refer to the ".dso" files on the DSO diskette.

G.1 INTRODUCTION

The High Voltage Module, Option 007, provides outputs of up to 100 Vp-p into 500Ω. The module consists of three high voltage amplifiers each of which accepts inputs from installed Arb Channels and an external summing input. Control of the module is through front panel menu or remote commands. The High Voltage Module must be installed in the slot normally reserved for Arb Channel 4. For High Voltage Module specifications, refer in this manual to paragraph A.2.16 Options, 007 High Voltage Module.

Note

The High Voltage Module setup cannot be stored using the INSTRUMENT / STORED SETUPS screen. You must set up this screen each time you power up.

This appendix covers:

- Installation of the High Voltage Module in the Model 295.
- Operation of the High Voltage Module including connections, screen descriptions, and general operation. Section 5 covers remote operation of the High Voltage Module.

G.2 HIGH VOLTAGE BOARD INSTALLATION

The High Voltage Module can be shipped installed in the Model 295 or separately. If shipped separately, the High Voltage Module must be installed in the Model 295 before use. To install the High Voltage Module in the field,

1. Disconnect the power cord from the Model 295.
2. Remove the cover plate or Arb Channel board from Channel 4; see figure G-1.
 - a. Remove the two screws from the rear panel cover plate of Channel 4, and remove the plate.
 - b. Or, remove the two screws securing the Channel 4 Arb Channel card, and remove the Arb Channel card out of the instrument.

Note

It may be necessary to loosen the screws holding Arb Channels 1, 2, and 3 (cover plates too) to ensure the High Voltage Modules is seated in position 4. Be sure to tighten the screws.

3. Slide the High Voltage Module into Channel 4. Secure the module with the two screws.
4. Connect the power cord to the Model 295.

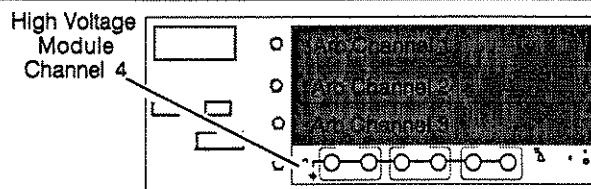

Figure G-1. High Voltage Module Location

After High Voltage Module installation, verify the High Voltage Module is installed by performing the following:

1. Turn on the POWER switch.
2. Press the front panel INSTRUMENT key.
3. Select OPTIONS from the menu.
4. From the menu, select HIGH VOLTAGE.
5. The screen now displays the *High Voltage Option* screen (figure G-2). An error message is displayed instead if the module is not installed.

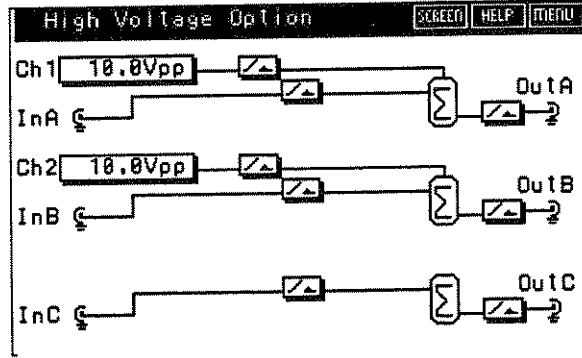

Figure G-2. High Voltage Screen

G.3 OPERATION

This paragraph describes the setup and operation of the High Voltage Module. Paragraph G.3.1 describes the module's connectors. Paragraph G.3.2 describes the High Voltage Option screen. Finally, paragraph G.3.3 explains operation of the High Voltage Module.

G.3.1 High Voltage Module Connections

The High Voltage Module consists of three high voltage channels each with two sets of connectors; MAIN OUT and EXT SUM IN. Figure G-3 illustrates the High Voltage Module's panel and table G-1 briefly describes the connectors and their functions.

Table G-1. High Voltage Module Connectors

Item	Description
1	Channels A, B, and C - Three High Voltage channels which contains Main Output and External Summing Input connectors. Each High Voltage channel sums up to two High Voltage Inputs with its initial Arb Channel and an external signal.
2	Main Out - High Voltage channel output connector. One each for Channels A, B, and C.

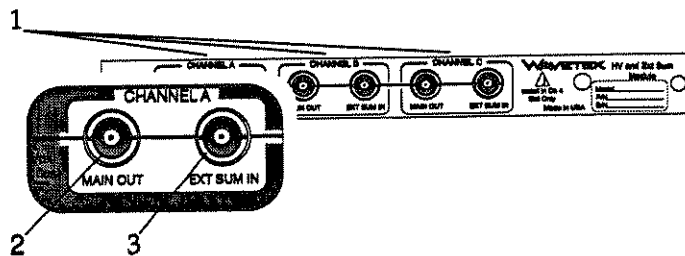

Figure G-3. High Voltage Module

Table G-1. High Voltage Module Connectors (Continued)

Item	Description	
3	Source Impedance	5Ω.
	Output Current	±80 mA.
	Range	10 Vp-p to 100 Vp-p (500Ω).
	Ex Sum In - High Voltage channel's external summing input connector. One each for Channels A, B, and C. Maximum input	
	10 Vp-p (±5Vdc).Gain	$10V_{out}/V_{in}$.

G.3.2 High Voltage Module Screen

The High Voltage Option screen gives you complete control of the High Voltage Module. You can only find this screen when the High Voltage Module is installed. You can also control the High Voltage Module using the SCPI subsystem: HVOLTage<n>; refer to section 5 of this manual.

Getting To The High Voltage Option Screen

1. Verify that the High Voltage Module is installed in position 4's slot before turning on the Model 295.
2. Connect the instrument to the primary power source, and press the POWER button to turn on the unit.
3. Press the INSTRUMENT key and select OPTIONS from the pop-up menu. See figure G-4.

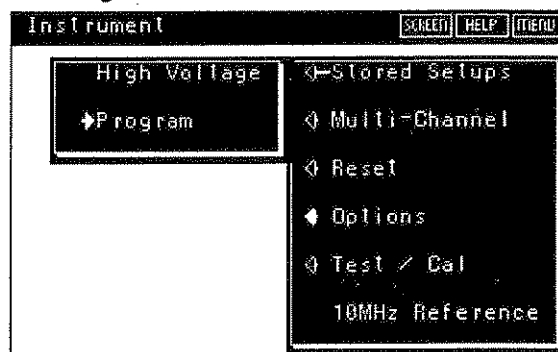

Figure G-4. Instrument/Option Screens

4. Select HIGH VOLTAGE from the OPTION screen. The Model 295 displays the High Voltage Option screen - figure G-5.

High Voltage Option Screen

Use the High Voltage Option screen to route Arb Channels into the high voltage amplifiers, to enable external summing input signals, to set up Arb Channel levels, and to connect high voltage amplifiers to their output connectors.

If an Arb Channel is not installed, the Channel Value field and its associated input switch will not be shown. High Voltage Input channel numbers appear on the screen in the Input Switch Group only when an initial channel is selected. Figure G-5 illustrates a unit with all three Arb Channels installed and selected on the screen; callouts in the figure only shows refers to the "A" amplifier section.

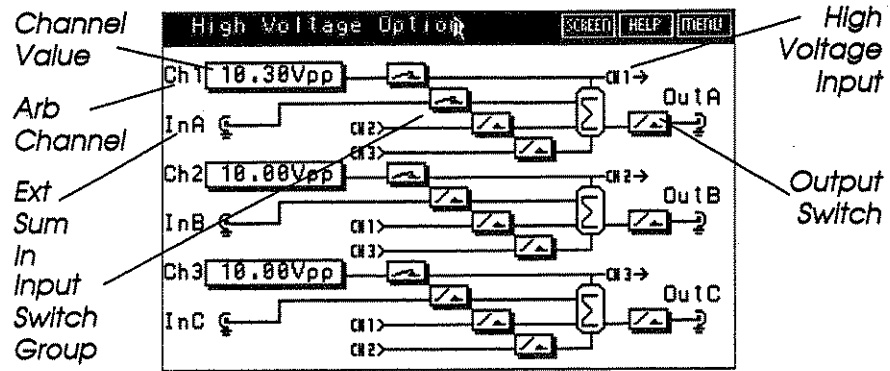

Figure G-5. High Voltage Option Screen

Input Switch Group

The Input Switch Group connects summing inputs to the high voltage amplifier. This screen can display three Input Switch Groups - one set for each high voltage amplifier. One switch in the group connects the Arb Channel (Ch1, Ch2, and Ch3) to the High Voltage Input. Another switch in the group connects the External Summing Input (In A, In B, In C) to the summing input. Other switches in the group connects other High Voltage Input channels (CH1, CH2, or CH3) to the high voltage amplifier.

Arb Channel Switch

This switch routes the scaled Arb Channel (displayed as Ch 1, Ch 2, and Ch 3) directly to its high voltage amplifier and to other High Voltage Inputs. The High Voltage Input numbers (displayed as CH 1, CH 2, and CH 3) also appears next to the switches.

Arb Channel 1 (Ch 1) connects to High Voltage Input - Amplifier A (Out A). Arb Channel 2 (Ch 2) connects to High Voltage Input - Amplifier B (Out B). Arb Channel 3 (Ch 3) connects to High Voltage Input - Amplifier C (Out C). Use the Channel Value to adjust the level driving the High Voltage Input.

Ex Sum In Switch

This switch connects the External Summing Input, displayed as InA, InB, and InC, to the summing input of the high voltage amplifier. Maximum input level to the connector is 5V_p, and bandwidth is >1MHz. The input signal is scaled by $-10V_{out}/V_{in}$.

High Voltage Inputs

Switches displayed as CH1, CH2, and CH3 connect High Voltage inputs to the high voltage amplifier. The level for these inputs is fixed at the value set by the Channel value. High Voltage Input numbers appear only after an Arb Channel is selected.

Channel Value

Selecting this field sets the Arb Channel's voltage level. Use either the front panel keypad or mouse to change the value. Programmable range is 10 Vp-p to 100 Vp-p (three digits of resolution) into 500Ω. At power on the Model 295 sets the value to 10 Vp-p. The Channel Values set from this screen are independent of the levels set from the *Channel Setup* screen. When this level is set, it defines the level all High Voltage Inputs. Thus, setting the level to

50 Vp-p sets the level to 50 Vp-p for all enabled High Voltage Inputs.

Remember, the High Voltage setup can not be stored.

The Model 295 allows you to sum levels that would normally exceed 100 Vp-p. This allows for waveform phasing or arbitrary waveform. The Model 295 will display a warning message when two or more summed input levels exceed a combined amplitude value of 100 Vp-p. But the Model 295 retains the programmed values.

Caution

If the sum of the voltage level for two or more High Voltage Inputs exceed 100 Vp-p, the Model 295 displays a warning message, but it accepts these levels because the actual sum depends on the signal phase. If the actual combined signal exceeds 100 Vp-p the output signal will be clipped if the peak level occurs at the same phase.

Output Switch

These switches connect high voltage amplifiers to their respective output connectors. Each time a switch is selected, the switch toggles between open and closed. Always wait to close an Output Switch after the high voltage channel is set up to minimize damage or shock hazard. The Model 295 disconnects all output switches at power up.

WARNING

Outputs from Out A, B, and C produce voltage levels as high as 100 Vp-p. Contacting these connectors, or wires from these connectors, could cause serious injuries.

G.3.3 High Voltage Module Operation

This paragraph illustrates how to combine the High Voltage Module with its menu screen to supply a high voltage output signal.

Output Considerations

Each High Voltage amplifier provides a low impedance source (5Ω) which can drive a load of up to 80 mA. The Channel Value, as well as the specifications in appendix A, are specified into a 500Ω termination. The main limiting factor, regardless of termination impedance, is the maximum Main Out's levels: 80 mA (max.) or 50 Vp (max.). Thus actual load impedances can vary depending on the output level and the output current. The graph, figure G-5, shows the output termination versus output level at a maximum output current of 80 mA. Interconnecting cable should have >10 MHz bandwidth. Cables with poor performance can be used with decreased bandwidth.

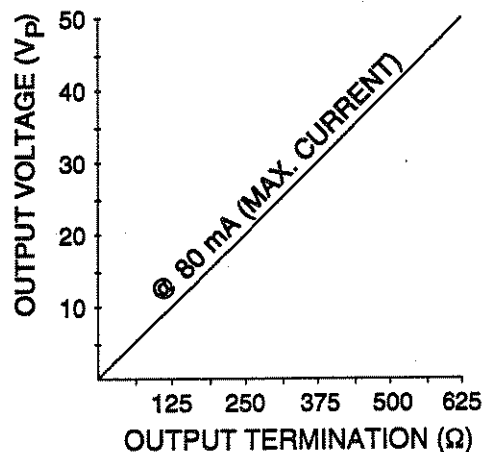

Figure G-5. Output Termination Versus Output Level

Total current output (all three outputs) of the High Voltage Option is limited to 210 mA [$|I_{CHA}| + |I_{CHB}| + |I_{CHC}| \leq 210 \text{ mA}$]. For best operation do not exceed this limit.

Operation

The next procedures provide a checklist for the High Voltage Module setup and operation.

First, basic operation: initial Arb Channel output.

Second, External Summing Input.

Finally, multiple channel operation.

It is assumed the High Voltage Module is installed in the Model 295 and functioning correctly.

Initial Arb Channel Output

1. Connect the Model 295 to its primary power source, and press the POWER button to turn the unit on.
2. Press the INSTRUMENT key, and select OPTION from the menu.
3. Select HIGH VOLTAGE from the menu.
4. Select the Arb Channel switch to route the signal to the High Voltage Input.
5. Set the Channel Value using the mouse or keypad.
6. Connect the amplifier's Main Out to the external circuit using the proper cabling and terminations.
7. Select the Output Switch to connect the amplifier to the Main Out connector.

External Sum Input

1. Perform steps 1 through 3 in *Initial Arb Channel Output*.
2. Select the "In" (External Summing Input) switch to external connector to the High Voltage input.
3. Connect the External Summing Input connector to an external signal source. Remember, the High Voltage Amplifier provides a gain of 10. For example, a 2Vp-p signal at the input connector produces a 20 Vp-p at the Main Out connector.

Note

If the external source has 50 Ω source impedance, and external 50 Ω must be placed at the Ext Sum In connector.

4. Perform steps 6 and 7 in *Initial Arb Channel Output*.

Multiple Channel Outputs

1. Perform steps 1 through 3 in *Single Arb Channel Output*.
2. Select the Arb Channel switch to route the Arb Channel to the High Voltage Input.
3. Set the Channel Value using the mouse or keypad.
4. Select the High Voltage Input switch to select an input from another Arb Channel. Remember, the Channel Value is fixed by the primary high voltage channel.
5. Select the "In" (External Summing Input) switch to external connector to the High Voltage input.
Connect the External Summing Input connector to an external signal source. Remember, the High Voltage Amplifier provides a gain of 10. For example, a 2Vp-p signal at the input connector produces a 20 Vp-p at the Main Out connector.
7. Perform steps 6 and 7 in *Initial Arb Channel Output*.

G.3.4 Remote

This appendix does not cover remote operation of the High Voltage board. For a description of the SCPI commands for the High Voltage board, refer to the HVOLTage<n> subsystem in section 5 of this manual.

Index

Symbols

(SIN X)/X
CHANNEL SETUP
SCREEN 4-11
*CAL? 5-38
*CLS 5-38
*ESE <NUMERIC VALUE> 5-38
*ESE? 5-39
*ESR? 5-39
*IDN? 5-39
*OPC 5-39
*OPC? 5-39
*RST 5-39
*SRE <NUMERIC VALUE> 5-39
*SRE? 5-39
*STB? 5-39
*TRG 5-39
*TST? 5-39
*WAI 5-40
.SCF
CONFIGURATION 4-74
[FORMAT]
DSO F-8
[ID]
DSO F-7
[SELECT N]
DSO F-7
[SETUP 1]
DSO F-7
[SOURCE<N>]
SCPI COMMANDS 5-20
10 MHZ REF 4-84
10 MHZ REF IN CONNec-
TOR 4-3

A

ACTIVE
SEQUENCE 4-58
WAVEFORMS 4-30
ADDRESS
IEEE-488 4-90
ADV TRIG
SEQUENCE 4-68
ADVANCE CONDITION
SEQUENCE 4-65
ADVANCE TIMING
SEQUENCE 4-68
ADVANCE TRIGGER

SEQUENCE 4-64
ADVANCE WINDOW
SEQUENCE 4-63
AM 4-16
AM IN AM MODULATION
INPUT 4-5
AMPLITUDE 3-17
CHANNEL SETUP
SCREEN 4-13
AMPLITUDE MODULATION 4-
16
ANALOG SUM
MULTI-CHANNEL 4-80
ARB CHANNEL
DSO F-4
ARB CHANNEL BOARD 4-4
ARB CHANNEL BOARD INSTAL-
LATION 2-4
ARROW KEYS 4-2
AUTO CAL 2-8
AUTOMATIC
SEQUENCE 4-64

B

BACKSPACE KEY 4-2
BATTERY 2-3
BAUD 4-90
BEEPER 4-89
BESSEL FILTER 4-16
BLINK TIME 4-88
BLOCK 4-38
MATH 4-44
BLOCK POSITION AND
VALUE 4-38
BOOLEAN FIELDS 3-6
BSP KEY 4-2

C

CALIBRATE
SCPI COMMANDS 5-13
CALIBRATION
TEST/CAL 4-83
CALIBRATION PROCEDURE 2-8
CE KEY 4-2
CH1, CH2, CH3
HIGH VOLTAGE
OPTION G-4
CH1, CH2, CH3

HIGH VOLTAGE
OPTION G-4
CHANGING A FIELD USING A
MOUSE 3-7
CHANGING A VALUE 3-10
CHANNEL 3-14, 4-2
TRIGGER SETUP 4-23
CHANNEL GROUP
MULTI-CHANNEL 4-78
CHANNEL GROUP SCREEN 4-
79
CHANNEL INPUT AND OUTPUT
CONNECTORS 4-4
CHANNEL NUMBERS
CHANNEL SETUP
SCREEN 4-6
CHANNEL SETUP SCREEN
AMPLITUDE 4-13
CHANNEL NUMBERS 4-
6, 4-7
CLOCK BNC 4-19
FREQUENCY 4-14
FREQUENCY - UNIT OF
MEASURE 4-15
MODULATION 4-16
OFFSET 4-14
OUTPUT ON/OFF 4-7
PHASE 4-21
SAMPLE FREQUENCY 4-15
SAMPLE PERIOD 4-15
SWEEP 4-18
SYNC MARKER 4-22
CHANNEL SETUP SCREEN 4-6
CHANNEL SETUP SCREEN
BASICS 3-13
CHANNEL TRIGGER POLAR-
ITY 4-28
CHANNEL VALUE
HIGH VOLTAGE
OPTION G-4
CLEAR ENTRY KEY 4-2
CLK IN/OUT CONNec-
TOR 4-5
CLOCK BNC
CHANNEL SETUP
SCREEN 4-19
CLOCK INPUT 4-5
CLOCK OUTPUT 4-5
CONNECTIONS
HIGH VOLTAGE

OPTION G-2
CONTINUOUS
 CHANNEL SETUP
 SCREEN 4-7
 SEQUENCE 4-63
CONTINUOUS SWEEP 4-9
COPY BLOCK
 WAVEFORM EDIT 4-46
COPY SEQUENCE 4-69
COPY WAVEFORMS 4-53, 4-76
COUNT
 SEQUENCE 4-63
CREATING A SEQUENCE 3-29
CREATING AN ARBITRARY
WAVEFORM 3-20
CREATING DSO DRIVERS F-
1, F-6
CURSOR POSITION 4-37
CURSOR VALUE 4-37

D

DATE & TIME 4-91
DAY 4-92
DELETE BLOCKS
 WAVEFORM EDIT 4-46
DELETE FILES 4-86
DELETE SEGMENT
 SEQUENCE 4-65
DELETE SEQUENCE 4-70
DELETE WAVEFORMS 4-54, 4-
77
DIALOG BOXES 3-7
DIGITAL STORAGE
OSCILLOSCOPES F-1
DISCARD
 SEQUENCE 4-67
 WAVEFORM EDIT 4-50
DOWNLOADING WAVEFORMS,
DSO F-4
DSO
 [FORMAT] F-8
 [ID] F-7
 [SELECT N] F-7
 [SETUP 1] F-7
 ARB CHANNEL F-4
 GPIB ADDRESS F-4
 SOURCE SELECT F-3
 SYSTEM REQUIREMENTS F-
 1
 WAVEFORM NAME F-4
DSO DOWNLOAD
INSTALLATION F-1
DSO DOWNLOAD PROGRAM

SCREEN F-2
DSO DOWNLOADING
WAVEFORMS F-4
DSO DRIVER F-6
 CREATING F-1, F-6
 EXAMPLES F-9
 FILES F-6
 LOADING F-3

E

EDIT FIELDS 3-6
EDIT SEQUENCE 4-60
 SEQUENCE 4-60
EDIT WAVEFORMS 4-35
EDITING AN ARBITRARY WAVE-
FORM 3-29
ELLIPTIC FILTER 4-16
END EDIT
 SEQUENCE 4-66
 WAVEFORM EDIT 4-49

ERRORS 3-13

EXAMPLES

 DSO DRIVERS F-9
EXPONENT KEY 4-2
EXPONENTIAL
 MATH 4-43
EXT SUM IN
 HIGH VOLTAGE
 OPTION G-2, G-4
EXTERNAL TRIG IN
 TRIGGER SETUP 4-26

F

FILES
 UTILITIES 4-85
FILTERS 4-16
FREEHAND
 WAVEFORM EDIT 4-45
FREQUENCY 3-16
 CHANNEL SETUP
 SCREEN 4-14
FREQUENCY - UNIT OF MEASURE
 CHANNEL SETUP
 SCREEN 4-15
FRONT PANEL 4-1
FRONT PANEL CONTROLS 4-1
FUNCTION 3-15
FUNCTION FIELD
 TRIGGER SETUP 4-24
FUNCTION VERSUS FRE-
QUENCY 4-14
FUNCTIONAL CHECKOUT 2-8

FUNCTIONS
 CHANNEL SETUP
 SCREEN 4-9
FUSE SELECTION/REPLACE-
MENT 2-2

G

GATED
 CHANNEL SETUP
 SCREEN 4-8
GET INFO
 RAM 4-87
GETTING HELP AND ERROR
MESSAGES 3-12
GO TO LOCAL
 REMOTE 4-90
GPIB ADDRESS
 DSO F-4
GPIB INPUT AND OUTPUT 4-4

H

HIGH VOLTAGE OPTION
 CH1, CH2, CH3 G-4
 CH1, CH2, CH3 G-4
 CHANNEL VALUE G-4
 CONTROL SCREEN G-3
 EX SUM IN G-4
 EXT SUM IN G-2
 INA, INB, INC G-4
 MAIN OUT G-2
 OPERATION G-2, G-5
 OUTPUT G-5
 OUTPUT
 CONSIDERATIONS G-5
 REMOTE G-7
HIGH VOLTAGE OPTION
INSTALLATION G-1
HORIZ SWEEP OUT
CONNECTOR 4-4

I

IEE 488.2 COMMANDS
 *ESE? 5-39
IEEE - 488 CONNECTOR 2-4
IEEE 488 4-89
IEEE 488.1 5-1
IEEE 488.2 5-1
IEEE 488.2 COMMANDS
 *CAL? 5-38
 *CLS 5-38
 *ESE <NUMERIC
 VALUE> 5-38

- *ESR? 5-39
- *IDN? 5-39
- *OPC 5-39
- *OPC? 5-39
- *RST 5-39
- *SRE <NUMERIC VALUE> 5-39
- *SRE? 5-39
- *STB? 5-39
- *TRG 5-39
- *TST? 5-39
- *WAI 5-40
- IEEE 488.2 COMMON COMMANDS 5-38
- IEEE-488 ADDRESS 4-90
- IEEE-488 CONNECTOR 4-4
- IEEE-488.2. (GPIB) SETUP 5-1
- IN A, INB, INC HIGH VOLTAGE OPTION G-4
- INFORMATION SCREEN WAVEFORM EDIT 4-35
- INITIAL SETUP 3-2
- INITIATE<N> SCPI COMMANDS 5-16
- INSERT SEGMENTS SEQUENCE 4-65
- INSTALLATION 2-3
- INSTRUMENT 4-73
- INSTRUMENT KEY 4-2

J

NO ENTRIES

K

NO ENTRIES

L

- LCD/SCOPE KEY 4-2
- LINE MATH 4-41
- LINE DRAW WAVEFORM EDIT 4-45
- LOAD SEQUENCE 4-60
- LOAD WAVEFORMS 4-33
- LOADING DSO DRIVERS F-3
- LOCAL 4-90
- REMOTE 4-90
- LOG

- MATH 4-44
- LOGARITHMIC SWEEP 4-19
- LONG AND SHORT FORM KEYWORDS 5-5
- LOOP SETTING SEQUENCE 4-65
- LOOP WINDOW SEQUENCE 4-63

M

- MAIN OUT HIGH VOLTAGE OPTION G-2
- MAIN OUT CONNECTOR 4-4
- MAN TRIG KEY 4-2
- MANUAL TRIGGER KEY 4-2
- MARKER OUT CONNECTORS 4-4
- MARKER POSITION WAVEFORMS 4-31
- MASTER TRIGGER TRIGGER SETUP 4-26
- MATH WAVEFORM EDIT 4-39
- MATH VALUES 4-39
- MENU CHANNEL SETUP SCREEN 4-15
- MENU ITEMS 3-7
- MENU KEY 4-2
- MINUTES 4-92
- MMEMORY SCPI COMMANDS 5-16, 5-17, 5-18
- MODE 3-16 TRIGGER SETUP 4-23
- MODEL 295 - DSO INTERCONNECTION F-5
- MODEL 295 DEFAULTS 5-20
- MODES CHANNEL SETUP SCREEN 4-7
- MODULATION CHANNEL SETUP SCREEN 4-16
- MONTH 4-92
- MOUSE 4-88
- MOUSE CONNECTION 2-4
- MOUSE CONNECTOR 4-4
- MULTI-CHANNEL 4-78 ANALOG SUM 4-80 CHANNEL GROUP 4-78

N

- NAME SEQUENCE 4-59
- NEGATIVE HAVERSINE CHANNEL SETUP SCREEN 4-11
- NEGATIVE RAMP CHANNEL SETUP SCREEN 4-11
- NEW SEQUENCE 4-71
- NEW WAVEFORMS 4-56
- NO FILTER 4-16
- NUMBER KEYS 4-1
- NUMBER OF POINTS 4-37

O

- OFFSET CHANNEL SETUP SCREEN 4-14
- OPERATION HIGH VOLTAGE OPTION G-2, G-5
- OPERATION REFERENCE 4-1
- OPTION007 F-1, G-1
- OUTPUT 3-14 HIGH VOLTAGE OPTION G-5
- OUTPUT CONSIDERATIONS HIGH VOLTAGE OPTION G-5
- OUTPUT ON/OFF CHANNEL SETUP SCREEN 4-7
- OUTPUT<N> SCPI COMMANDS 5-18
- OVERVIEW 3-1

P

- PACKAGING 2-2
- PCX 4-86
- PERIOD CHANNEL SETUP SCREEN 4-15
- PHASE CHANNEL SETUP SCREEN 4-21
- POINT EDIT WAVEFORM EDIT 4-47
- POSITIVE HAVERSINE CHANNEL SETUP

SCREEN 4-11
 POSITIVE RAMP
 CHANNEL SETUP
 SCREEN 4-11
 POSN POSITION MARKER
 OUTPUT 4-4
 POWER CONNECTOR 4-3
 POWER SWITCH 4-3
 PREPARATION FOR
 USE 2-2
 PREVIOUS CHANNEL'S TRIG OUT
 TRIGGER SETUP 4-27
 PROGRAM MESSAGE 5-10
 PROGRAM MESSAGE DELIMITERS
 5-10
 PROGRAM MESSAGE TERMINATORS
 5-11
 PROGRAM MESSAGE UNIT 5-10
 PULSE
 TRIANGLE 4-42

Q

NO ENTRIES

R

RAM
 GET INFO 4-87
 RANDOM
 CHANNEL SETUP
 SCREEN 4-11
 MATH 4-44
 REAR PANEL 4-3
 RECALL
 SETTING 4-75
 RECEIVING AND INSPECTING SHIPMENTS
 2-1
 REMOTE 4-90
 REMOTE 4-89
 BAUD 4-90
 GO TO LOCAL 4-90
 HIGH VOLTAGE
 OPTION G-7
 LOCAL 4-90
 RENAME
 SEQUENCE 4-67
 RESET 4-81
 RESEt<N>
 SCPI COMMANDS 5-19
 RETURNING EQUIPMENT FOR REPAIR
 2-1
 RIGHT MOUSE BUTTON

WAVEFORM EDIT 4-37
 ROUTINE MAINTENANCE 2-15
 RS-232 4-89
 RS-232 INPUT AND OUTPUT 4-4
 RS-232C CONNECTOR 2-5
 RS-232C SETUP 5-3

S

SAMPLE FREQUENCY
 CHANNEL SETUP
 SCREEN 4-15
 SAMPLe PERIOD
 CHANNEL SETUP
 SCREEN 4-15
 SCM 4-16
 SCOPE EDIT SCREEN 4-37
 SCP 5-1
 SCPI COMMAND
 SYSTEM 5-28
 TEST<N> 5-30
 TRACE<N> 5-31
 TRIGGER<N> 5-34
 SCPI COMMAND SUMMARY 5-4
 SCPI COMMANDS
 [SOURCE<N>] 5-20
 CALIBRATE 5-13
 INITIATE<N> 5-16
 MMEMORY 5-16, 5-17, 5-18
 OUTPUT<N> 5-18
 RESEt<N> 5-19
 SCPI COMMANDS 5-13
 SCREEN COLORS 4-89
 SCREEN KEYS 4-2
 SEGMENT NUMBE
 SEQUENCE 4-65
 SEGMENT NUMBER
 SEQUENCE 4-62
 SELECT KEY 4-2
 SELECTOR FIELDS 3-6
 SELF-TEST
 TEST/CAL 4-83
 SEQUENCE 4-58
 ACTIVE 4-58
 ADV TRIG 4-68
 ADVANCE CONDITION 4-65
 ADVANCE TIMING 4-68
 ADVANCE TRIGGER 4-64
 ADVANCE WINDOW 4-63

AUTOMATIC 4-64
 CHANNEL SETUP
 SCREEN 4-12
 CONTINUOUS 4-63
 COPY SEQUENCE 4-69
 COUNT 4-63
 DELETE SEGMENT 4-65
 DELETE SEQUENCE 4-70
 DISCARD 4-67
 END EDIT 4-66
 INSERT SEGMENTS 4-65
 LOAD 4-60
 LOOP SETTING 4-65
 LOOP WINDOW 4-63
 NAME 4-59
 NEW 4-71
 RENAME 4-67
 SEGMENT NUMBE 4-65
 SEGMENT NUMBER 4-62
 SEQUENCE CATALOG 4-61
 SEQUENCE EDIT 4-61
 SEQUENCE NAME 4-62
 SOURCE 4-59
 STORE IN BATTERY-BACKED
 RAM 4-67
 STORE ON DISK 4-67
 TRIGGER CONDITIONS 4-68
 WAVEFORM CATALOG 4-62
 WAVEFORM WINDOW 4-62
 SEQUENCE CATALOG 4-60
 SEQUENCE 4-61
 SEQUENCE EDIT
 SEQUENCE 4-61
 SEQUENCE KEY 4-2
 SEQUENCE NAME 4-72
 SEQUENCE 4-62
 SETTING
 RECALL 4-75
 STORE 4-73
 SETUP 4-73
 SINC ((SIN X)/X)
 CHANNEL SETUP
 SCREEN 4-11
 SINE
 CHANNEL SETUP
 SCREEN 4-10
 MATH 4-41
 SIZE
 WAVEFORMS 4-30
 SOFT KEYS 4-2
 SOURCE

SEQUENCE 4-59
 SOURCE SELECT
 DSO F-3
 SQUARE
 CHANNEL SETUP
 SCREEN 4-11
 STANDARD COMMANDS FOR
 PROGRAMMABLE INSTRUMENTS
 (SC 5-1
 STARTUP.SCF 4-86
 STORAGE 2-2
 STORE
 SETTING 4-73
 STORE IN BATTERY-BACKED
 RAM
 SEQUENCE 4-67
 STORE ON DISK
 SEQUENCE 4-67
 WAVEFORM EDIT 4-49
 STORING A SEQUENCE 3-37
 STORING A WAVEFORM 3-27
 SUPPRESSED CARRIER MODULA-
 TION 4-16
 SWEEP
 CHANNEL SETUP
 SCREEN 4-18
 SWEEP & RESET 4-18
 SWEEP & REVERSE 4-18
 SWEEP DIRECTION 4-19
 SWEEP START FREQUENCY 4-19
 SWEEP TIME 4-19
 SYNC MARKER
 CHANNEL SETUP
 SCREEN 4-22
 SYNC OUT 3-15
 SYSTEM
 SCPI COMMAND 5-28
 SYSTEM INPUT AND OUTPUT
 CONNECTORS 4-3
 SYSTEM TRIGGER
 TRIGGER SETUP 4-25
 SYSTEM TRIGGER CONNEC-
 TOR 4-3
 SYSTEM TRIGGER LEVEL 4-28

T

T
 MATH 4-44
 TANGENT
 MATH 4-43

TEST/CAL
 CALIBRATION 4-83
 SELF-TEST 4-83
 TEST<N>
 SCPI COMMAND 5-30
 THE MAIN SCREENS 3-3
 TOOLS
 WAVEFORM EDIT 4-39
 TRACE<N>
 SCPI COMMAND 5-31
 TRIANGLE
 CHANNEL SETUP
 SCREEN 4-10
 MATH 4-42
 TRIG IN CONNECTOR 4-4
 TRIGGER CONDITIONS
 SEQUENCE 4-68
 TRIGGER KEY 4-3
 TRIGGER OUT
 TRIGGER SETUP 4-27
 TRIGGER SETUP 4-23
 CHANNEL 4-23
 COUNT 4-24
 EXTERNAL TRIG IN 4-26
 FUNCTION FIELD 4-24
 MASTER TRIGGER 4-26
 MODE 4-23
 PREVIOUS CHANNEL'S TRIG
 OUT 4-27
 SYSTEM TRIGGER 4-25
 TRIGGER OUT 4-27
 TRIGGER SOURCE 4-25
 TRIGGER SOURCE
 TRIGGER SETUP 4-25
 TRIGGER<N>
 SCPI COMMAND 5-34
 TRIGGERED
 CHANNEL SETUP
 SCREEN 4-7
 TRIGGERED & HOLD SWEEP 4-
 9
 TRIGGERED SWEEP 4-9
 TXT 4-86

U

UNITS
 WAVEFORM EDIT 4-51
 UNZOOM
 WAVEFORM EDIT 4-47
 USING SEQUENCES 3-29

USING THE CHANNEL SETUP
 SCREENS 3-13
 USING THE KEYPAD TO CHANGE
 VALUES 3-10
 USING THE MOUSE AND
 KEYPAD 3-7
 UTILITIES 4-85
 FILES 4-85
 UTILITIES KEY 4-3

V

VERSION REPORT 4-93
 VERTICAL MOVE
 WAVEFORM EDIT 4-45
 VERTICAL RESIZE
 WAVEFORM EDIT 4-46
 VIEWING ANGLE 4-88

W

WAVEFORM
 CHANNEL SETUP
 SCREEN 4-11
 WAVEFORM CATALOG 4-
 34, 4-35
 SEQUENCE 4-62
 WAVEFORM EDIT
 INFORMATION SCREEN 4-
 35
 WAVEFORM LIMITS 4-32
 WAVEFORM NAME 4-30, 4-37
 DSO F-4
 WAVEFORM NEW 4-56
 WAVEFORM WINDOW
 SEQUENCE 4-62
 WAVEFORMS 4-29
 ACTIVE 4-30
 MARKER POSITION 4-31
 SIZE 4-30
 WAVEFORMS KEY 4-2
 WAVE TEST BASIC 3-1

Z

Z-AXIS
 WAVEFORM EDIT 4-52
 Z-AXIS OUT CONNECTOR 4-
 4
 ZOOM
 WAVEFORM EDIT 4-47

1
2
3
4
5
6
7
8
9
10
11
12
13
14
15
16
17
18
19
20
21
22
23
24
25
26
27
28
29
30
31
32
33
34
35
36
37
38
39
40
41
42
43
44
45
46
47
48
49
50
51
52
53
54
55
56
57
58
59
60
61
62
63
64
65
66
67
68
69
70
71
72
73
74
75
76
77
78
79
80
81
82
83
84
85
86
87
88
89
90
91
92
93
94
95
96
97
98
99
100