

DL1720E/DL1740E/DL1740EL
Digital Oscilloscope
Communication Interface
U S E R ' S M A N U A L

Foreward

Thank you for purchasing YOKOGAWA's DL1720E/DL1740E/DL1740EL Digital Oscilloscope.

This Communication Interface User's Manual describes the functions and commands of GP-IB, USB, and Ethernet (optional) interface. To ensure proper use of the GP-IB/USB/Ethernet (optional) interfaces, please read this manual thoroughly.

Keep the manual in a safe place for quick reference whenever a question arises. Four manuals are provided with the DL1720E/DL1740E/DL1740EL including this Communication Interface User's Manual.

Manual Name	Manual No.	Description
DL1720E/DL1740E/DL1740EL User's Manual	IM 701730-01E	Describes all functions except for the communications functions and operation procedures of the instrument.
DL1720E/DL1740E/DL1740EL Communication Interface User's Manual (CD-ROM)	IM 701730-17E	Describes the communications functions of the GP-IB/USB/Ethernet interfaces.
DL1720E/DL1740E/DL1740EL Operation Guide	IM 701730-02E	Provides a brief explanation of the functions and basic operating procedures of the DL1720E/DL1740E/DL1740EL.
DL1740E/DL1740EL Serial Bus Signal Analysis Function User's Manual	IM 701730-51E	Describes the serial bus signal analysis function (option).

Notes

- The contents of this manual are subject to change without prior notice as a result of improvements in instrument's performance and functions.
- Every effort has been made in the preparation of this manual to ensure the accuracy of its contents. However, should you have any questions or find any errors, please contact your nearest YOKOGAWA representative.
- Copying or reproduction of all or any part of the contents of this manual without YOKOGAWA's permission is strictly prohibited.

USB Interface and Ethernet Interface

- The following items must be installed on the PC to access the communications functions using the USB interface.
 1. A dedicated library for the USB interface.
 2. A USB device driver for the PC-to-DL1720E/DL1740E/DL1740EL connection.
- The following item must be installed on the PC to access the communications functions using the Ethernet interface.
 1. A dedicated library for the network interface.

The library and the driver above can be downloaded from the following Web page.
http://www.yokogawa.com/tm/dl_driver.htm

Trademarks

- Microsoft, MS-DOS, Visual C++, Windows, Windows NT, and Windows XP are either registered trademarks or trademarks of Microsoft Corporation in the United States and/or other countries.
- Adobe, Acrobat, and PostScript are either trademarks or registered trademarks of Adobe Systems incorporated.
- For purposes of this manual, the TM and ® symbols do not accompany their respective trademark names or registered trademark names.
- The TCP/IP software and TCP/IP-related documentation accompanying this instrument was developed/created from the BSD Networking Software, Release 1 licensed from the Regents of the University of California.
- Other product names are trademarks or registered trademarks of their respective holders.

Revisions

1st Edition: July 2004

How to Use this Manual

Structure of this Manual

This User's Manual consists of seven chapters, an Appendix and an Index as described below.

Chapter 1 Overview of the GP-IB Interface

Describes the functions and specifications of the GP-IB interface.

Chapter 2 Overview of the USB Interface

Describes the functions and specifications of the USB interface.

Chapter 3 Overview of the Ethernet Interface (Option)

Describes the functions and specifications of the Ethernet interface.

Chapter 4 Before Programming

Describes formats used when sending a command.

Chapter 5 Commands

Describes each command.

Chapter 6 Status Report

Describes the status byte, various registers and queues.

Chapter 7 Sample Programs

Sample programs, written in Visual BASIC, for MS-DOS/V machines equipped with the following GP-IB board: PCI-GPIB IEEE-488.2, from National Instruments.

Appendix

Contains references including the ASCII character code table.

Index

Provides an index ordered alphabetically.

Conventions Used in this Manual

Symbols

The following symbols are used in to this manual.



Improper handling or use can lead to injury to the user or damage to the instrument. This symbol appears on the instrument to indicate that the user must refer to the user's manual for special instructions. The same symbol appears in the corresponding place in the user's manual to identify those instructions. In the manual, the symbol is used in conjunction with the word "WARNING" or "CAUTION."

WARNING

Describes precautions that should be observed to prevent serious injury or death to the user.

CAUTION

Describes precautions that should be observed to prevent minor or moderate injury, or damage to the instrument.

Note

Provides important information for the proper operation of the instrument.

Terms Used for Descriptions of Operations

The following terms are used in chapters 1 to 3 to distinguish certain features in descriptions.

Procedure

Carry out steps in the order shown. The operating procedures are given with the assumption that you are not familiar with the operation. Thus, it may not be necessary to carry out all the steps when changing settings.

Explanation

Describes settings and restrictions relating to the operation.

Notations Used in the Procedures

Panel Keys and Soft keys

Bold characters used in the procedural explanations indicate characters that are marked on the panel keys or the characters of the soft keys displayed on the screen menu.

SHIFT+Panel Key

SHIFT+key means you will press the SHIFT key to turn ON the green indicator that is located above the SHIFT key and then press the panel key. The setup menu marked in purple above the panel key that you pressed appears on the screen.

Jog Shuttle & SELECT

Jog shuttle & SELECT indicates selecting or setting parameters and entering values using the jog shuttle, the SELECT key, and other keys. For details on the procedure, see section 4.1 or 4.2.

Units

k: Denotes "1000." Example: 100 kS/s

K: Denotes "1024." Example: 459 KB (file data size)

Symbols Used in Syntax Descriptions

Symbols which are used in the syntax descriptions in Chapter 4 are shown below. These symbols are referred to as BNF notation (Backus-Naur Form). For detailed information, refer to page 4-5 to 4-6.

Symbol	Description	Example	Example of Input
<x>	Defined value	CHANnel <x> <x>=1 to 4	-> CHANNEL2
{ } 	One of the options in { } is selected. Exclusive OR	COUPLing {AC DC GND}	-> COUPLING AC
[]	Abbreviated	TRIGger [:SIMple]:SLOPe	-> TRIGger: SLOPe

Contents

Foreward	i
How to Use this Manual	iii
Chapter 1 Overview of the GP-IB Interface	
1.1 Names of the Parts and their Functions	1-1
1.2 Connection via the GP-IB Interface	1-2
1.3 GP-IB Interface Functions	1-3
1.4 GP-IB Interface Specifications	1-4
1.5 Setting up this Instrument (GP-IB)	1-5
1.6 Response to Interface Messages	1-6
Chapter 2 USB Interface	
2.1 Names of the Parts and their Functions	2-1
2.2 USB Interface Functions and Specifications	2-2
2.3 Connection via the USB Interface	2-4
2.4 Setting up this Instrument (USB)	2-5
Chapter 3 Ethernet Interface (Option)	
3.1 Names of the Parts and their Functions	3-1
3.2 Ethernet Interface Functions and Specifications	3-2
3.3 Connection via the Ethernet Interface	3-4
3.4 Setting up this Instrument (Network)	3-5
Chapter 4 Before Programming	
4.1 Messages	4-1
4.2 Commands	4-3
4.3 Response	4-5
4.4 Data	4-5
4.5 Synchronization with the Controller	4-8
Chapter 5 Commands	
5.1 A List of Commands	5-1
5.2 ACQUIRE Group	5-15
5.3 ASETUP Group	5-17
5.4 CALIBRATE Group	5-17
5.5 CHANNEL Group	5-19
5.6 CLEAR Group	5-22
5.7 COMMUNICATE Group	5-23
5.8 CURSOR Group	5-25
5.9 DISPLAY Group	5-33
5.10 FILE Group	5-38
5.11 GONOGO Group	5-44
5.12 HCOPI Group	5-52
5.13 HISTORY Group	5-55
5.14 IMAGE Group	5-60
5.15 INITIALIZE Group	5-62
5.16 MATH Group	5-63
5.17 MEASURE Group	5-66
5.18 PHASE Group	5-78

5.19	PRESet Group	5-79
5.20	RECall Group	5-82
5.21	SEARCh Group	5-83
5.22	SNAP Group	5-92
5.23	SStart Group	5-92
5.24	STARt Group	5-92
5.25	STATus Group	5-93
5.26	STOP Group	5-94
5.27	STORe Group	5-95
5.28	SYSTem Group	5-96
5.29	TIMebase Group	5-99
5.30	TRIGger Group	5-100
5.31	WAVEform Group	5-111
5.32	XY Group	5-114
5.33	ZOOM Group	5-116
5.34	Common Command Group	5-118

Chapter 6 Status Report

6.1	Overview of the Status Report	6-1
6.2	Status Byte	6-2
6.3	Standard Event Register	6-3
6.4	Extended Event Register	6-4
6.5	Output Queue and Error Queue	6-5

Chapter 7 Sample Program

7.1	Before Programming	7-1
7.2	Image of Sample Program	7-2
7.3	Initialize/Error/Execute	7-3
7.4	Sets/Queries the T/Div	7-6
7.5	Data Output in Word Format (2 bytes)	7-8
7.6	Sets/Queries Measure Value	7-11

Appendix

Appendix 1	ASCII Character Code	App-1
Appendix 2	Error Messages	App-2
Appendix 3	Overview of IEEE 488.2-1992	App-4
Appendix 4	Waveform Parameter Name Correspondence Table	App-6

Index



Chapter 1 Overview of the GP-IB Interface

1.1 Names of the Parts and their Functions

Front Panel

• DL1740E/DL1740EL

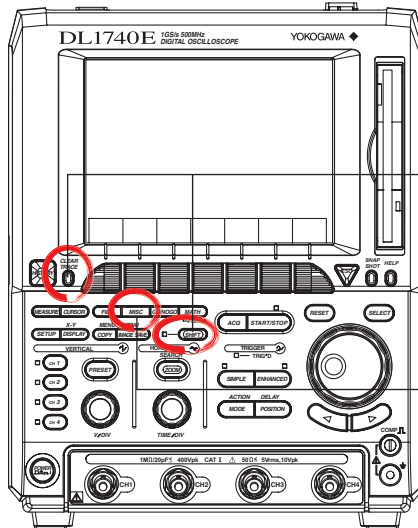

SHIFT Key+CLEAR TRACE Key
Press to switch from remote mode to local mode which allows key operation. However, this is not possible if Local Lockout has been set by the controller (refer to page 1-6).

MISC Key (Page 1-5)
Press to enter the communication settings such as the address and the timeout.

• DL1720E

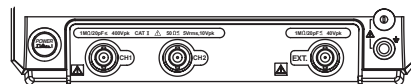

Rear Panel

• DL1740E/DL1740EL

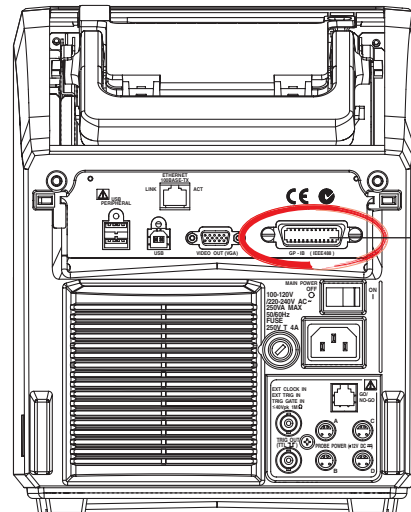

GP-IB Connector
This connector is for connecting the controller (such as a PC) with the GP-IB cable. For information on how to connect the GP-IB cable, refer to the following page.

• DL1720E

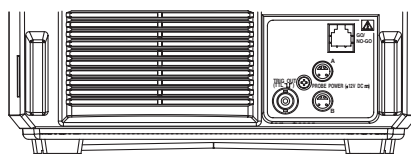

1.2 Connection via the GP-IB Interface

GP-IB Cable

The GP-IB connector on the side panel of the DL1720E/DL1740E/DL1740EL is a 24-pin connector that conforms to IEEE Standard 488-1978. Use a GP-IB cable that also conforms to IEEE Standard 488-1978.

Connection Method

Connect the GP-IB cable as shown below.

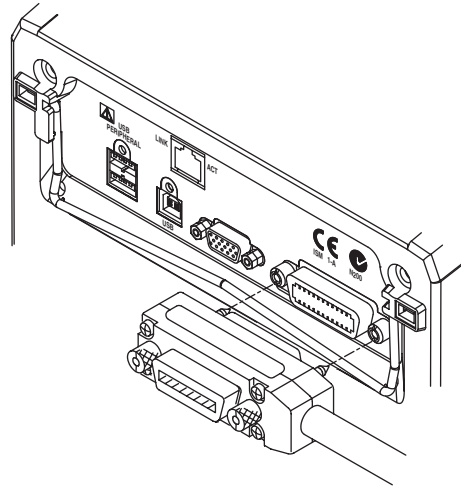

Connection Precautions

- Be sure to tighten the screws on the GP-IB cable connector firmly.
- The instrument can be connected to more than one item of equipment (e.g. a personal computer) if more than one GP-IB cable is used. However, it is not possible to connect more than 15 items of equipment (including the controller) to a single bus.
- If you connect the instrument to more than one item of equipment, make sure that a different address is used for each item.
- Each connecting cable must be 2 m or less in length.
- The total length of all the cables must not exceed 20 m.
- While communications are in progress, more than two-thirds of the connected equipment items must be turned ON.
- When connecting more than one item of equipment, connect them so that the connection route forms a star or linear configuration. Loop or parallel wiring is not allowed.

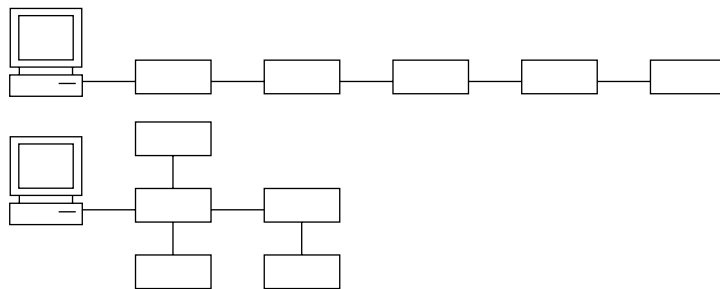

CAUTION

Be sure to switch off power to both your PC and the oscilloscope before connecting or disconnecting cables. Failure to switch power off may cause internal circuit failure or improper operation.

1.3 GP-IB Interface Functions

GP-IB Interface Functions

Listener Function

- Allows you to make the settings which you can make using the panel keys on the instrument, except for the power ON/OFF and GP-IB communications settings.
- Receives commands from a controller requesting output of setup and waveform data.
- Also receives status report commands.

Talker Function

Outputs setup and waveform data.

Note

The listen-only, talk-only and controller functions are not available on this instrument.

Switching between Remote and Local Mode

When Switched from Local to Remote Mode

Remote mode is activated when a REN (Remote Enable) message is received from a controller while local mode is active.

- REMOTE is displayed on the upper right of the screen.
- All front panel keys except **SHIFT+CLEAR TRACE** can no longer be operated any more.
- Settings entered in local mode are retained.

When Switched from Remote to Local Mode

Pressing **SHIFT+CLEAR TRACE** in remote mode puts the instrument in local mode. However, this is not possible if Local Lockout has been set by the controller (page 1-6).

- The REMOTE indicator on the upper right of the screen is turned off.
- All front panel keys are operative.
- Settings entered in remote mode are retained.

Note

The GP-IB interface cannot be used simultaneously with other communications interfaces (USB, or Ethernet).

1.4 GP-IB Interface Specifications

GP-IB Interface Specifications

Electrical and Mechanical Specifications:	Conforms to IEEE Standard 488-1978.
Interface Functions:	Refer to the table below.
Protocol:	Conforms to IEEE Standard 488.2-1992.
Code:	ISO (ASCII) code
Mode:	Addressable mode
Address Setting:	Addresses 0 to 30 can be selected from the GP-IB setting screen, displayed when you press the MISC key.
Remote Mode Clear:	Remote mode can be cleared by pressing SHIFT key+CLEAR TRACE key. However, this is not possible if Local Lockout has been set by the controller.

Interface Functions

Function	Subset Name	Description
Source Handshaking	SH1	Full source handshaking capability
Acceptor Handshaking	AH1	Full acceptor handshaking capability
Talker	T6	Basic talker capability, serial polling, untalk on MLA (My Listen Address), no talk-only capability
Listener	L4	Basic listener capability, unlisten on MTA (My Talk Address), no listen-only capability
Service Request	SR1	Full service request capability
Remote Local	RL1	Full remote/local capability
Parallel Poll	PP0	No parallel polling capability
Device Clear	DC1	Full device clear capability
Device Trigger	DT0	No device trigger capability
Controller	C0	No controller function
Electrical Characteristic	E1	Open collector

Data Transfer Rate

The table below shows approximate response times for output of waveform data, assuming the following configuration.

Model:	701730
Controller:	PC (Pentium4 12.3 GHz, OS (Windows 2000 Professional)
GB-IB Board:	NI PCI-GPIB
Programming Language:	Visual C++

Data Volume	Byte Format	Word Format	ASCII Format
1000	approx. 62.7 ms	approx. 68.9 ms	approx. 458 ms
10000	approx. 109.6 ms	approx. 156.3 ms	approx. 4.5 s
100000	approx. 646.2 ms	approx. 1216.4 ms	approx. 45.3 s
1000000	approx. 6268.1 ms	approx. 11720.0 ms	approx. 452.7 s

1.5 Setting up this Instrument (GP-IB)

Procedure

Selecting the Communication Interface

1. Press **MISC**. The MISC menu appears.
2. Press the **Remote Control** soft key. The Remote Cntl menu appears.

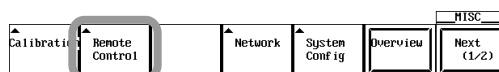

3. Press the **Device** soft key to select GP-IB.

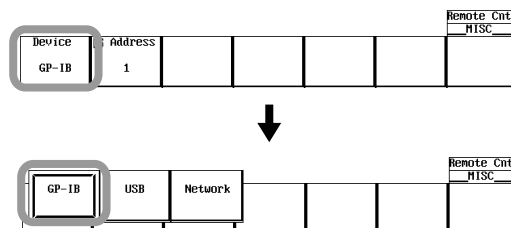

Note

Only the communications interfaces selected under Device are available. If commands are sent using an unselected communications interface, the command will not be received.

Setting the Address

4. Press the **Address** soft key.



5. Turn the **jog shuttle** to set the desired address.

Explanation

When you make settings which can be made using the front panel keys of the instrument or when you output setup data or waveform data using the controller, the following settings must be made.

Setting the Address

This function allows you to set the instrument's address for addressable mode within the range of 0 to 30. Each item of equipment connected via a GP-IB interface has its own address, by which it can be identified. Care must be taken to ensure that all interconnected devices are assigned unique addresses.

Note

Do not change the address while the GP-IB interface is being used by the controller.

1.6 Response to Interface Messages

Response to Interface Message

Response to a Uni-line Message

IFC (InterFace Clear)

Clears the talker and listener. Stops output if data is being output.

REN (Remote ENable)

Switches between remote and local modes.

IDY (Identify) is not supported.

Response to a Multi-Line Message (Address Command)

GTL (Go To Local)

Switches to local mode.

SDC (Selected Device Clear)

Clears the program message (command) which is currently being output. Also clears the output queue (page 6-5).

*OPC and *OPC? will be disabled if they are currently being executed.

*WAI and :COMMunicate:WAIT will be stopped immediately.

PPC (Parallel Poll Configure), GET (Group Execute Trigger) and TCT (Take Control) are not supported.

Response to a Multi-Line Message (Universal Command)

LLO (Local LockOut)

Invalidates SHIFT+CLEAR on the front panel to disable switching to local mode.

DCL (Device CLear)

Same as SDC.

SPE (Serial Poll Enable)

Sets the talker function to serial poll mode for all equipment connected to the communications bus. The controller performs polling on equipment sequentially.

SPD (Serial Poll Disable)

Clears serial poll mode as the talker function for all equipment connected to the communications bus.

PPU (Parallel Poll Unconfigure) is not supported.

What is an Interface Message?

An interface message is also called an interface command or bus command, and is issued by the controller. Interface messages are classified as follows.

Uni-Line Messages

Messages are transferred through a single control line. The following three types of uni-line message are available.

IFC (InterFace Clear)

REN (Remote ENable)

IDY (IDentify)

Multi-Line Message

Eight data lines are used to transmit a message. Multi-line messages are classified as follows.

Address Commands

Valid when the equipment is designated as a listener or a talker. The following five address commands are available.

- Commands valid for equipment designated as a listener;
 - GTL (Go To Local)
 - SDC (Selected Device Clear)
 - PPC (Parallel Poll Configure)
 - GET (Group Execute Trigger)
- Command valid for equipment designated as a talker;
 - TCT (Take ConTrol)

Universal Commands

Valid for any item of equipment, irrespective of whether the item is designated as a listener or a talker. The following five universal commands are available.

- LLO (Local LockOut)
- DCL (Device CLear)
- PPU(Parallel Poll Unconfigure)
- SPE (Serial Poll Enable)
- SPD (Serial Poll Disable)

In addition to the above commands, a listener address, talker address on secondary command can be sent in an interface message.

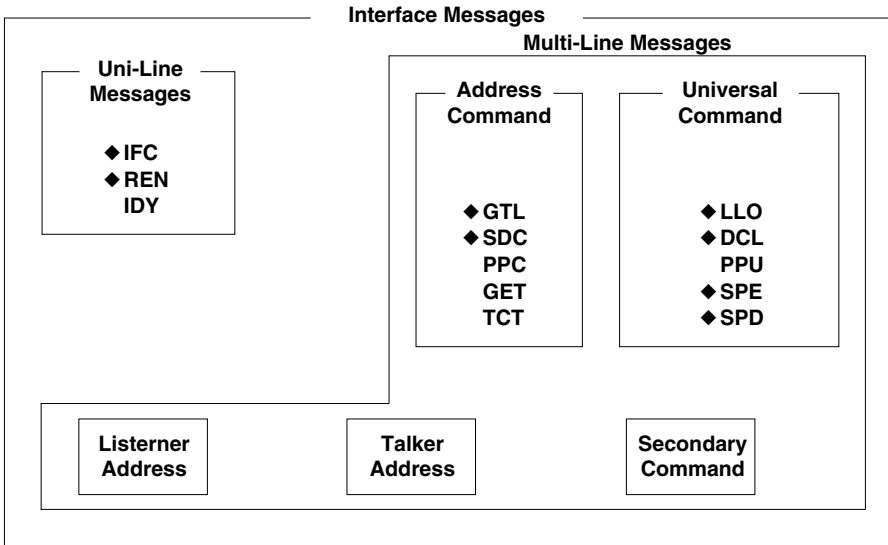

Messages marked with a "◆" are interface messages supported by the DL1720E/DL1740E/DL1740EL.

Note

Differences between SDC and DCL

The SDC command is an address command and requires that both the talker and listener be designated; however DCL is a universal command and does not require that the talker and listener be designated. Therefore, SDC is used for particular items of equipment, while DCL can be used for any equipment connected to the communications bus.

Chapter 2 USB Interface

2.1 Names of the Parts and their Functions

Front Panel

- DL1740E/DL1740EL

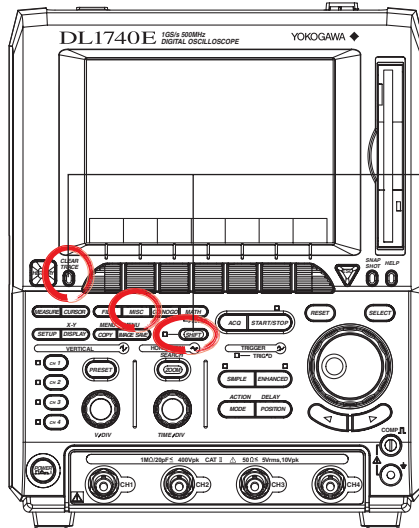

SHIFT Key+CLEAR TRACE Key
 Press to switch from remote mode to local mode which allows key operation. However, this is not possible if Local Lockout has been set by the controller (refer to page 2-2).

MISC Key (Page 2-5)
 Press to enter the communication settings such as the ID value.

- DL1720E

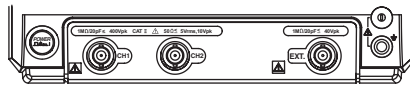

Rear Panel

- DL1740E/DL1740EL

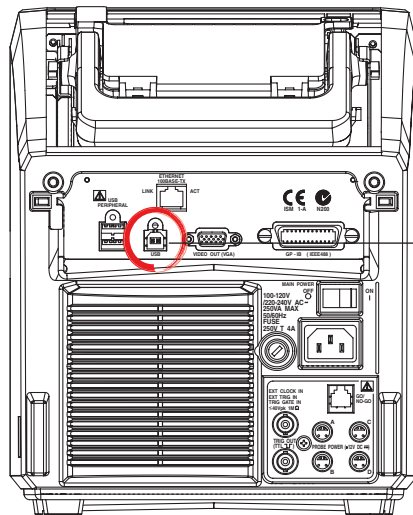

USB Interface Connector
 This connector is for connecting the controller (such as a PC) with the USB cable. For information on how to connect the USB cable, refer to page 2-4.

- DL1720E

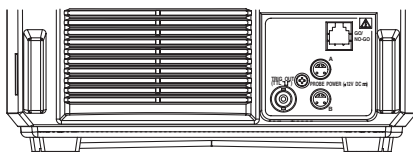

2.2 USB Interface Functions and Specifications

Reception Function

You can specify the same settings as those specified by front panel key operations. Receives output requests for measured and computed data, setting parameters of the panel, and error codes.

Transmission Function

Outputs measured and computed data.
 Outputs setting parameters of the panel and the status byte.
 Outputs error codes that are generated.

USB Interface Specifications

Electrical and Mechanical Specifications: Conforms to USB Rev.1.0
 Connector: Type B connector (receptacle)
 Number of Ports: 1
 Power Supply: Self-powered
 Supported Systems: PC system supported. Models with a standard USB port that operates on Windows 98 SE, Windows Me, Windows 2000, or Windows XP (a separate device driver is required for connection to the PC).

Data Transfer Rate

The table below shows approximate response times for output of waveform data, assuming the following configuration.

Model: 701730
 Controller: PC(Pentium4 1.3GHz, USB1.1), OS(Windows2000 Professional)
 GB-IB Board: NI AT-GPIB/TNT(PNP)
 Programming Language: Visual C++

Data Volume	Byte Format	Word Format	ASCII Format
1000	approx. 39.9 ms	approx. 40.0 ms	approx. 240.0 ms
10000	approx. 50.4 ms	approx. 82.7 ms	approx. 2.0 s
100000	approx. 250.8 ms	approx. 403.2 ms	approx. 20.0 s
1000000	approx. 2166.1 ms	approx. 3475.1 ms	approx. 204.6 s

Switching between Remote and Local Mode

When Switching from Local to Remote Mode

If the DL1720E/DL1740E/DL1740EL receives a ":COMMunicate:REMOte ON" command from the PC when it is in the local mode, it switches to the remote mode.

- REMOTE is displayed at the lower left corner of the screen.
- All keys except **SHIFT+CLEAR TRACE** are disabled.
- The settings that existed in the local mode are maintained even when the instrument switches to the remote mode.

When Switching from Remote to Local Mode

Pressing **SHIFT+CLEAR TRACE** when the instrument is in the remote mode causes the instrument to switch to the local mode. However, this is void when the DL1720E/DL1740E/DL1740EL has received a ":COMMunicate:LOCKout ON" command from the PC (local lockout condition). When the DL1720E/DL1740E/DL1740EL receives a ":COMMunicate:REMOte OFF" command from the PC, the DL1720E/DL1740E/DL1740EL switches to the local mode regardless of the local lock condition.

- REMOTE indication at the lower right corner disappears.
- Key operations are enabled.
- The settings that existed in the remote mode are maintained even when the instrument switches to the local mode.

Note

The USB interface cannot be used simultaneously with other communications interface (GP-IB, or Ethernet).

2.3 Connection via the USB Interface

Connector and Signal Names

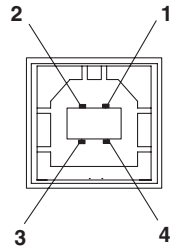

Pin No.	Signal Name
1	VBUS: +5 V
2	D-: -Data
3	D+: +Data
4	GND: Ground

Connection Precautions

- Connect the USB cable by inserting the connector firmly into the USB connector.
- When connecting multiple devices using USB hubs, connect the instrument to the USB hub that is closest to the controller.
- Do not mistakenly insert the USB cable to the GO/NO-GO output terminal. This may cause damage to the instrument.
- Do not connect/disconnect the USB cable to/from the instrument during the period between the time power is turned ON and operation becomes possible (approximately 20 to 30 seconds). This may cause damage to the instrument.

2.4 Setting up this Instrument (USB)

Procedure

Selecting the Communication Interface

1. Press **MISC**. The MISC menu appears.
2. Press the **Remote Control** soft key. The Remote Cntl menu appears.

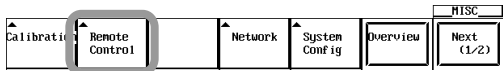

3. Press the **Device** soft key to select USB.

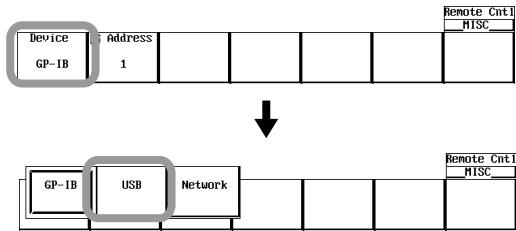

Note

Only the communications interfaces selected under Device are available. If commands are sent using an unselected communications interface, the command will not be received.

Setting the ID Value

4. Press the **Own ID** soft key.

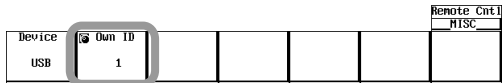

5. Turn the **jog shuttle** to set the ID value.

Explanation

Carry out the following settings when using a controller to set information that can be specified through key operation on the instrument or when outputting setting parameters or output waveform data to the controller.

Setting the ID Value

Set the ID value of the instrument within the following range:
1 to 127

You can connect multiple devices to a host controller on the USB. If the instrument is connected to multiple devices in a single USB system, the ID value is used by the host controller to identify each device. Therefore, unique ID values must be assigned to the instrument within a single system.

Note

Do not change the ID value while using the USB.

Chapter 3 Ethernet Interface (Option)

3.1 Names of the Parts and their Functions

Front Panel

• DL1740E/DL1740EL

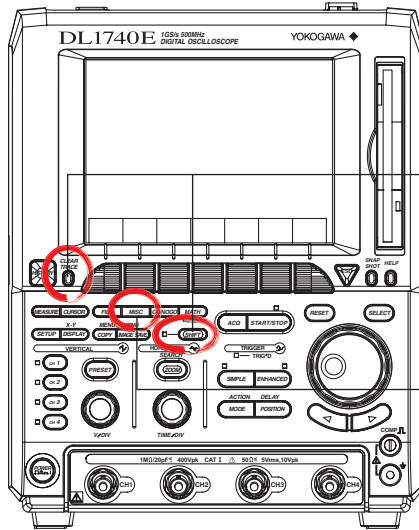

SHIFT Key+CLEAR TRACE Key
Press to switch from remote mode to local mode which allows key operation. However, this is not possible if Local Lockout has been set by the controller (refer to page 3-2).

MISC Key (Page 3-5)
Press to confirm the user name and password.

• DL1720E

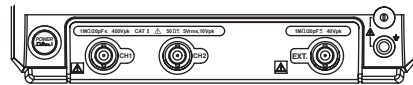

Rear Panel

• DL1740E/DL1740EL

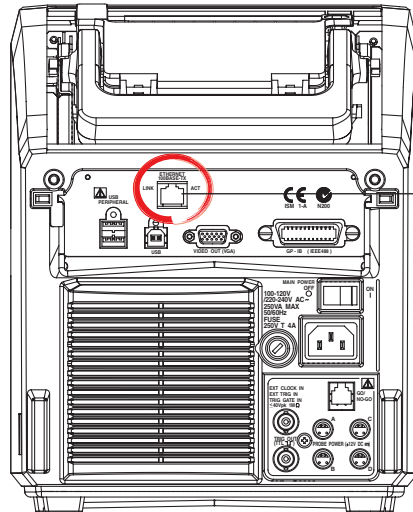

Ethernet Interface Connector
This connector is for connecting the controller (such as a PC) with the Ethernet cable. For information on how to connect the USB cable, refer to page 3-4.

• DL1720E

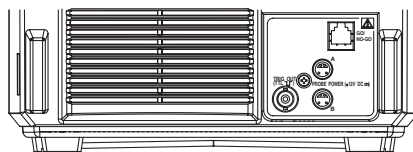

3.2 Ethernet Interface Functions and Specifications

Ethernet Interface Functions

Reception Function

You can specify the same settings as those specified by front panel key operations. Receives output requests for measured and computed data, setting parameters of the panel, and error codes.

Transmission Function

Measured/computed data can be output.
Panel setup information and the status byte can be output.
Error codes which have occurred can be output.

Ethernet Interface Specifications

Electrical and Mechanical Specifications: IEEE802.3 Compliant
No. of simultaneous connections: 1
Port No.: 10001/tcp

Data Transfer Rate

The table below shows approximate response times for output of waveform data, assuming the following configuration.

Model: 701730
Controller: PC (Pentium4 1.3 GHz, OS (Windows 2000 Professional)
Network Adaptor: Corega FEther PCI-TXL
Programming Language: Visual C++

Data Volume	Byte Format	Word Format	ASCII Format
1000	approx. 3.9 ms	approx. 5.0 ms	approx. 197.2 ms
10000	approx. 21.8 ms	approx. 39.6 ms	approx. 1.9 s
100000	approx. 182.1 ms	approx. 401.5 ms	approx. 19.6 s
1000000	approx. 1908.8 ms	approx. 3006.3 ms	approx. 197.2 s

Switching between Remote and Local Mode

When Switched from Local to Remote

Remote mode is activated when the ":COMMunicate:REMOte ON" command is received from a controller while local mode is active.

- REMOTE is displayed on the upper right of the screen.
- All front panel keys except **SHIFT +CLEAR TRACE** can no longer be operated.
- Settings entered in local mode are retained even when switching to remote mode.

When Switched from Remote to Local Mode

Pressing **SHIFT +CLEAR TRACE** in remote mode puts the instrument in local mode. However, this is not possible when the ":COMMunicate:REMOte ON" command is received from the computer while Local Lockout mode is active. Local mode is activated when the ":COMMunicate:REMOte OFF" command is received regardless of Local Lockout.

- The REMOTE indicator on the upper right of the screen is turned off.
- All front panel keys are operative.
- Settings entered in remote mode are retained even when switching to local mode.

Note

The Ethernet interface cannot be used simultaneously with other communications interfaces (GP-IB, or USB).

User Verification Function

The user must enter a user name and password for the Ethernet interface when connecting to the network. The user name and password is set on the instrument in the Remote Cntl setting screen under the MISC menu. For details, see section 3.4, "Setting up this Instrument (Network)."

3.3 Connection via the Ethernet Interface

Connection Method

Connect a UTP (Unshielded Twisted-Pair) or STP (Shielded Twisted-Pair) cable that has been connected to a hub to the 100BASE-TX port on the rear panel of the unit.

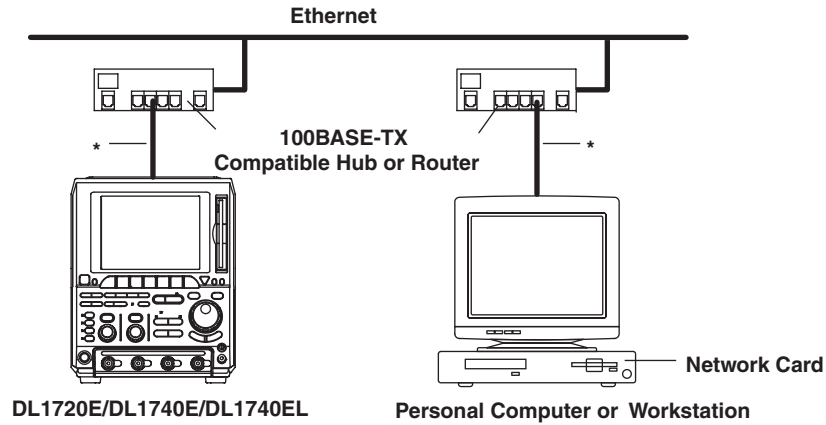

* UTP Cable or STP Cable (Straight Cable)

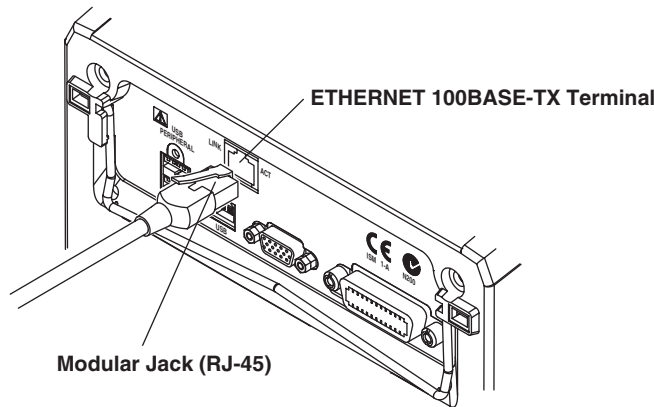

Connection Precautions

- You must use a straight cable when connecting the unit to a personal computer or a workstation. We cannot guarantee results using a cross cable.
- When using a UTP cable (straight cable), be sure to use only a category 5 cable.

3.4 Setting up this Instrument (Network)

Procedure

Selecting the Communication Interface

1. Press **MISC**. The MISC menu appears.
2. Press the **Remote Control** soft key. The Remote Cntl menu appears.

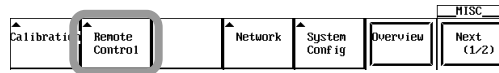

3. Press the **Device** soft key, and select Network.

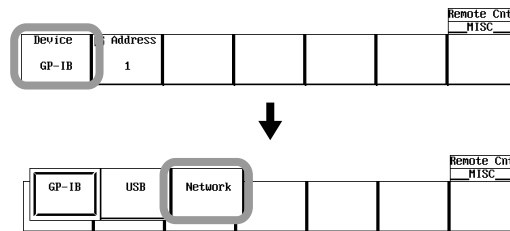

Note

Only the communications interfaces selected under Device are available. If commands are sent using an unselected communications interface, the command will not be received.

Setting the User Name, Password, and Timeout Time

4. Press the **User Account** soft key. The User Account dialog box appears.



5. Use the **jog shuttle & SELECT** to set the User Name.
If you do not wish to limit access, use the anonymous setting.
If access is to be limited, enter a user name of 15 characters or less.
6. Use the **jog shuttle & SELECT** to enter the Password of 15 characters or less.
Reenter the password to confirm.
7. Use the **jog shuttle & SELECT** to the Time Out.

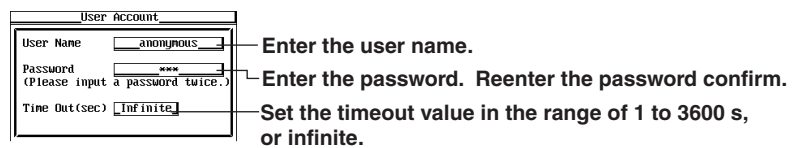

Note

- For (soft) keyboard operation, see section 4.2, "Entering Values and Strings" in user's manual IM701730-01E.
- The user name and password are case sensitive.

TCP/IP Settings

The following TCP/IP settings must be entered in order to use the Ethernet interface functions.

- IP Address
- Subnet Mask
- Default Gateway

For details about how to enter these settings, see section 13.2, "Setting Up the TCP/IP" in user's manual IM701730-01E.

3.4 Setting up this Instrument (Network)

Explanation

Use the settings below to setup communications so that you can input settings on the instrument using the controller, or output settings or values to the controller.

Setting the User Name and Password

There is a user verification function for the Ethernet interface. The user name and password are set on the instrument ahead of time.

- User Name Setting
15 characters or less may be used. The default value is anonymous.
- Password Setting
15 characters or less may be used.

Setting the Timeout Time

If the unit is not being accessed at the specified timeout time, the connection to the network will be automatically closed.

TCP/IP Settings

For details, see section 13.2, "Setting Up the TCP/IP" in user's manual IM701730-01E.

Note

- If a user verification error occurs, the connection to the instrument is cut.
 - If the login name is anonymous, it is not necessary to enter a password.
 - When changing the user name, password, timeout time, or TCP/IP settings, the settings will not take effect until the unit is turned OFF then back ON again.
-

Chapter 4 Before Programming

4.1 Messages

Blocks of message data are transferred between the controller and this instrument during communications. Messages sent from the controller to this instrument are called program messages, and messages sent back from this instrument to the controller are called response messages.

If a program message contains a query command, i.e. a command which requests a response, this instrument returns a response message. A single response message is always returned in reply to a program message.

Program Messages

The format of a program message is shown below.

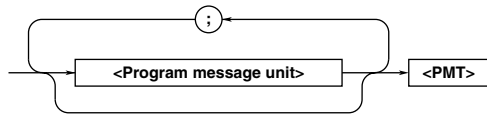

<Program Message Unit>

A program message consists of one or more program message units; each unit corresponds to one command. This instrument executes commands one by one according to the order in which they are received.

Program message units are delimited by a "; ."

For a description of the format of the program message unit, refer to the explanation given further below.

Example: `ACQUIRE:MODE NORMAL;COUNT 1<PMT>`
 Unit Unit

<PMT>

PMT is a terminator used to terminate each program message. The following three types of terminator are available.

NL (New Line): Same as LF (Line Feed). ASCII code "0AH" is used.

^END : END message defined in IEEE488.1. (EOI signal)
 (The data byte sent with an END message will be the final item of the program message unit.)

NL^END : NL with an END message attached (NL is not included in the program message unit.)

Program Message Unit Format

The format of a program message unit is shown below.

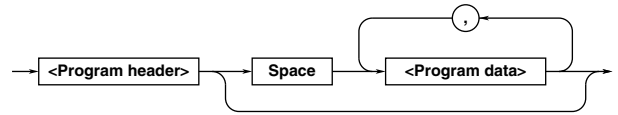

<Program Header>

A program header is used to indicate the command type. For details, refer to page 4-3.

<Program Data>

If certain conditions are required for the execution of a command, program data must be added. Program data must be separated from the header by a space (ASCII code "20H"). If multiple items of program data are included, they must be separated by a ", " (comma). For details, refer to page 4-5.

Example: `ACQUIRE:MODE NORMAL<PMT>`
 Header Data

Response Messages

The format of a response message is shown below.

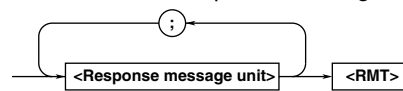

<Response Message Units>

A response message consists of one or more response message units: each response message unit corresponds to one response.

Response message units are delimited by a "; ."

For the response message format, refer to the next page.

Example: `ACQUIRE:MODE NORMAL;COUNT 1<RMT>`
 Unit Unit

<RMT>

RMT is the terminator used for every response message. Only one type of response message is available; NL^END.

4.1 Messages

Response Message Unit Format

The format of a program message unit is shown below.

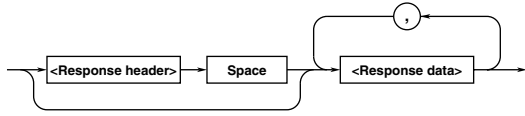

<Response Header>

A response header sometimes precedes the response data. Response data must be separated from the header by a space. For details, refer to page 4-5.

<Response Data>

Response data is used to define a response. If multiple items of response data are used, they must be separated by a ", " (comma). For details, refer to page 4-5.

Example

1.25E-02<RMT> :ACQUIRE:MODE NORMAL<RMT>
Data Header Data

If a program message contains more than one query, responses are made in the same order as the queries. Normally, each query returns only one response message unit, but there are some queries which return more than one response message unit. The first response message unit always responds to the first query, but it is not always true that the 'n'th unit always responds to the 'n'th query. Therefore, if you want to make sure that a response is made to each query, the program message must be divided up into individual messages.

Points to Note Concerning Message Transmission

- It is always possible to send a program message if the previous message which was sent did not contain any queries.
- If the previous message contained a query, it is not possible to send another program message until a response message has been received. An error will occur if a program message is sent before a response message has been received in its entirety. A response message which has not been received will be discarded.
- If an attempt is made by the controller to receive a response message, even if there is no response message, an error will occur. An error will also occur if the controller makes an attempt to receive a response message before transmission of a program message has been completed.
- If a program message of more than one unit is sent and some of the units are incomplete, this instrument receives program message units which the instrument thinks complete and attempts to execute them. However, these attempts may not always be successful and a response may not always be returned, even if the program message contains queries.

Dead Lock

This instrument has a buffer memory in which both program and response messages of 1024 bytes or more can be stored. (The number of bytes available will vary depending on the operating state of the instrument.) If both buffer memories become full at the same time, this instrument becomes inoperative. This state is called deadlock. In this case, operation can be resumed by discarding the response message. No dead lock will occur, if the size of the program message including the PMT is kept below 1024 bytes. Furthermore, no deadlock will occur if the program message does not contain a query.

4.2 Commands

There are three types of command (program header) which can be sent from the controller to this instrument. They differ in the format of their program headers.

They are

- Common command header
- Compound header
- Simple header

Common Command Header

Commands defined in IEEE 488.2-1987 are called common commands. The header format of a common command is shown below. An asterisk (*) must always be attached to the beginning of a command.

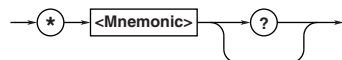

An example of a common command

*CLS

Compound Header

Commands designed to be used only with this instrument are classified and arranged in a hierarchy according to their function. The format of a compound header is illustrated below. A colon (:) must be used when specifying a lower-level header.

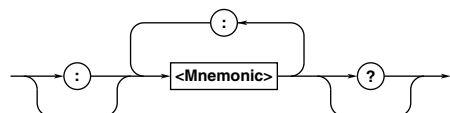

An example of a compound header

:ACQUIRE:MODE

Simple Header

These commands (headers) are functionally independent of each other and are not arranged hierarchically. The format of a simple header is shown below.

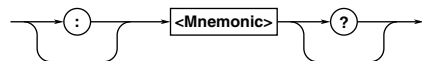

An example of a simple header

:START

Note

A mnemonic is a character string made up of alphanumeric characters.

When Concatenating Commands

Command Group

A command group is a group of commands which have the same compound header. A command group may contain sub-groups.

Example Commands relating to acquisition settings

```
:ACQUIRE:AVERAGE:COUNT
:ACQUIRE:MODE
:ACQUIRE:AVERAGE:EWEIGHT
:ACQUIRE:REPETITIVE
:ACQUIRE:CLOCK
:ACQUIRE:RLENGTH
:ACQUIRE:COUNT
```

When Concatenating Commands of the Same Group

This instrument stores the hierarchical level of the command which is currently being executed, and performs analysis on the assumption that the next command to be sent will also belong to the same level. Therefore, it is possible to omit the header if the commands belong to the same group.

```
Example :ACQUIRE:MODE NORMAL;
COUNT 1<PMT>
```

When Concatenating Commands of Different Groups

A colon (:) must be included before the header of a command, if the command does not belong to the same group as the preceding command. It is impossible to omit a colon (:).

```
Example :ACQUIRE:MODE NORMAL;:DISPLAY:
FORMAT SINGLE<PMT>
```

When Concatenating Simple Headers

When you type in a simple header after another command, you must include a colon (:) before the simple header. It is impossible to omit a colon (:).

```
Example :ACQUIRE:MODE NORMAL;:START<PMT>
```

When Concatenating Common Commands

Common commands defined in IEEE 488.2-1987 are independent of hierarchical level. Thus, it is not necessary to add a colon (:) before a common command.

```
Example :ACQUIRE:MODE NORMAL;*CLS;
COUNT 1<PMT>
```

4.2 Commands

When Separating Commands with <PMT>

If a terminator is used to separate two commands, each command is a separate message. Therefore, the common header must be typed in for each command even when commands of the same command group are being concatenated.

```
Example :ACQuire:MODE NORMAl<PMT>:
        ACQuire:COUNT 1<PMT>
```

Upper-level Query

An upper-level query is a compound header to which a question mark is appended. Execution of an upper-level query allows all a group's settings to be output at once. Some query groups comprising more than three hierarchical levels can output all their lower level settings.

```
Example :CHANnel1?<PMT> -> :CHANNEL1:
        DISPLAY ON;LABEL "CH1 ";
        COUPLING DC;POSITION 0.00;
        PROBE 10;VDIV 50.0E+00;
        BWIDTH FULL;OFFSET 0.0E+00;
        LSCALE:MODE 0
```

In reply to a query, a response can be returned as a program message to this instrument. Transmitting a response can restore the settings made when the query was executed. However, some upper-level queries will not return setup data which is not currently in use. Note that not all a group's information will necessarily be sent out as a response.

Header Interpretation Rules

This instrument interprets the header received according to the following rules.

- Mnemonics are not case sensitive.
Example "CURSOR" can also be written as "cursor" or "Cursor."
- The lowercase part of a header can be omitted.
Example "CURSOR" can also be written as "CURSO" or "CURS."
- If the header ends with a question mark, the command is a query. It is not possible to omit the question mark.
Example "CURSOR?" cannot be abbreviated to anything shorter than "CURS?."
- If the "x" at the end of a mnemonic is omitted, it is assumed to be "1."
Example If "CHANNEL<x>" is written as "CHAN," this represents "CHANNEL1."
- Any part of a command enclosed by [] can be omitted.
Example "TRIGGER[:SIMPLle]:LEVEL" can be written as "TRIG:LEV."
However, a part enclosed by [] cannot be omitted if it is located at the end of an upper-level query.
Example "TRIGGER?" and "TRIGGER:SIMPLE?" belong to different upper-level query levels.

4.3 Response

On receiving a query from the controller, this instrument returns a response message to the controller. A response message is sent in one of the following two forms.

- **Response Consisting of a Header and Data**
If the query can be used as a program message without any change, a command header is attached to the query, which is then returned.
Example :ACQUIRE:MODE?<PMT> ->
:ACQUIRE:MODE NORMAL<RMT>
- **Response Consisting of Data Only**
If the query cannot be used as a program message unless changes are made to it (i.e. it is a query-only command), no header is attached and only the data is returned. Some query-only commands can be returned after a header is attached to them.
Example :MEASURE:CHANNEL1:PTOPEAK:VALUE?<PMT> -> 10.0E+00<RMT>

When Returning a Response without a Header

It is possible to remove the header from a response consisting of a header and data. The "COMMUNICATE:HEADER" command is used to do this.

Abbreviated Form

Normally, the lowercase part is removed from a response header before the response is returned to the controller. Naturally, the full form of the header can also be used. For this, the "COMMUNICATE:VERBOSE" command is used. The part enclosed by [] is also omitted in the abbreviated form.

4.4 Data

Data

A data section comes after the header. A space must be included between the header and the data. The data contains conditions and values. Data is classified as below.

Data	Description
<Decimal>	Value expressed as a decimal number (Example: CH2's probe attenuation -> CHANNEL2:PROBE 100)
<Voltage><Time> <Frequency><Current>	Physical value (Example: Time axis range -> TIMEbase:TDIV 1US)
<Register>	Register value expressed as either binary, octal, decimal or hexadecimal (Example: Extended event register value -> STATUS:EUSE #HFE)
<Character data>	Specified character string (mnemonic). Can be selected from { } (Example: CH2 input coupling -> CHANNEL2:COUPLING {AC DC GND})
<Boolean>	Indicates ON/OFF. Set to ON, OFF or value (Example: CH2 display ON -> CHANNEL2:DISPLAY ON)
<Character string data>	Arbitrary character string (Example: Comment on screen-data output -> HCOPIY:COMMENT "ABCDEF")
<Filename>	Gives the name of a file. (Example: Name of file to be saved -> FILE:SAVE:WAVEFORM:NAME "CASE1")
<Block data>	Arbitrary 8-bit data (Example: Response to acquired waveform data -> #800000010ABCDEF8HJ)

<Decimal>

<Decimal> indicates a value expressed as a decimal number, as shown in the table below. Decimal values are given in the NR form specified in ANSI X3. 42-1975.

Symbol	Description	Example
<NR1>	Integer	125 -1 +1000
<NR2>	Fixed point number	125.0 -.90 +001.
<NR3>	Floating point number	125.0E+0 -9E-1 +.1E4
<NRf>	Any of the forms <NR1> to <NR3> is allowed.	

- Decimal values which are sent from the controller to this instrument can be sent in any of the forms to <NR3>. In this case, <NRf> appears.
- For response messages which are returned from this instrument to the controller, the form (<NR1> to <NR3> to be used) is determined by the query. The same form is used, irrespective of whether the value is large or small.
- In the case of <NR3>, the "+" after the "E" can be omitted, but the "-" cannot.
- If a value outside the setting range is entered, the value will be normalized so that it is just inside the range.
- If the value has more than the significant number of digits, the value will be rounded.

4.4 Data

<Voltage>, <Time>, <Frequency>, and <Current>

<Voltage>, <Time>, <Frequency>, and <Current> indicate decimal values which have physical significance. <Multiplier> or <Unit> can be attached to <NRf>. They can be entered in any of the following forms.

Form	Example
<NRf><Multiplier><Unit>	5MV
<NRf><Unit>	5E-3V
<NRf><Multiplier>	5M
<NRf>	5E-3

<Multiplier>

Multipliers which can be used are shown below.

Symbol	Word	Description
EX	Exa	10 ¹⁸
PE	Peta	10 ¹⁵
T	Tera	10 ¹²
G	Giga	10 ⁹
MA	Mega	10 ⁶
K	Kilo	10 ³
M	Milli	10 ⁻³
U	Micro	10 ⁻⁶
N	Nano	10 ⁻⁹
P	Pico	10 ⁻¹²
F	Femto	10 ⁻¹⁵
A	Atto	10 ⁻¹⁸

<Unit>

Units which can be used are shown below.

Symbol	Word	Description
V	Volt	Voltage
S	Second	Time
HZ	Hertz	Frequency
MHZ	Megahertz	Frequency
A	Ampere	Current

- <Multiplier> and <Unit> are not case sensitive.
- "U" is used to indicate "μ."
- "MA" is used for Mega (M) to distinguish it from Milli, except for in the case of Megahertz, which is expressed as "MHZ." Hence, it is not permissible to use "M" (Milli) for Hertz.
- If both <Multiplier> and <Unit> are omitted, the default unit will be used.
- Response messages are always expressed in <NR3> form. Neither <Multiplier> nor <Unit> is used, therefore the default unit is used.

<Register>

<Register> indicates an integer, and can be expressed in hexadecimal, octal, or binary as well as as a decimal number. <Register> is used when each bit of a value has a particular meaning. <Register> is expressed in one of the following forms.

Form	Example
<NRf>	1
#H-<Hexadecimal value made up of the digits 0 to 9, and A to F>	#H0F
#Q-<Octal value made up of the digits 0 to 7>	#Q777
#B-<Binary value made up of the digits 0 and 1>	#B001100

- <Register> is not case sensitive.
- Response messages are always expressed as <NR1>.

<Character Data>

<Character data> is a specified string of character data (a mnemonic). It is mainly used to indicate options, and is chosen from the character strings given in { }. For interpretation rules, refer to "Header Interpretation Rules" on page 4-4.

Form	Example
{AC DC GND}	AC

- As with a header, the "COMMunicate:VERbose" command can be used to return a response message in its full form. Alternatively, the abbreviated form can be used.
- The "COMMunicate:HEADer" command does not affect <character data>.

<Boolean>

<Boolean> is data which indicates ON or OFF, and is expressed in one of the following forms.

Form	Example
{ON OFF <NRf>}	ON OFF 1 0

- When <Boolean> is expressed in <NRf> form, OFF is selected if the rounded integer value is "0" and ON is selected if the rounded integer is "Not 0."
- A response message is always "1" if the value is ON and "0" if it is OFF.

<Character String Data>

<Character string data> is not a specified character string like <Character data>. It is an arbitrary character string. A character string must be enclosed in apostrophes (') or double quotation marks (").

Form	Example
<Character string data>	'ABC' "IEEE488.2-1987"

- Response messages are always enclosed in double quotation marks.
- If a character string contains a double quotation mark ("), the double quotation mark will be replaced by two concatenated double quotation marks (" "). This rule also applies to a single quotation mark within a character string.
- <Character string data> is an arbitrary character string, therefore this instrument assumes that the remaining program message units are part of the character string if no apostrophe (') or double quotation mark (") is encountered. As a result, no error will be detected if a quotation mark is omitted.

<Filename>

Gives the name of a file. The format is as follows.

Form	Example
{<NRf> <Character data> <Character string>}	1 CASE "CASE"

- If you input an <NRf> value, the system converts the value (after rounding to the nearest integer) to the corresponding 8-character ASCII string. (If you set the value to 1, the name becomes "00000001".) Note that negative values are not allowed.
- The first 12 characters of <Character Data> are assigned as the file name.
- The first 14 characters of <Character String Data> are assigned as the file name.
- Response messages always return filenames as <character string> arguments.

<Block Data>

<Block data> is arbitrary 8-bit data. <Block data> is only used for response messages. Response messages are expressed in the following form.

Form	Example
#N<N-digit decimal value><Data byte string>	#800000010ABCDEFGHIJ

- #N
Indicates that the data is <Block data>. "N" is an ASCII character string number (digits) which indicates the number of data bytes that follow.
- <N-digits decimal value>
Indicates the number of bytes of data. (Example: 00000010=10 bytes)
- <Data byte string>
The actual data. (Example: ABCDEFGHIJ)
- Data is comprised of 8-bit values (0 to 255). This means that the ASCII code "0AH," which stands for "NL," can also be a code used for data. Hence, care must be taken when programming the controller.

4.5 Synchronization with the Controller

Overlap Commands and Sequential Commands

There are two kinds of command; overlap commands and sequential commands. Execution of an overlap command may start before execution of the previously sent command is completed.

The "CHANnel1:VDIV" command, for example, is a sequential command. Assume that you set a new V/div value and immediately request return of the new value, as follows:

```
:CHANnel1:VDIV 5V;VIDV?<PMT>
```

In this case, the oscilloscope always returns the newest setting ("5V"). This is because it always completes processing of the current sequential command (in this case, "VDIV 5V") before moving on to the next command ("VIDV?").

In contrast, assume that you begin a file load and then immediately query the V/div value:

```
:FILE:LOAD:SETup:EXECute "CASE1";:  
CHANnel1:VDIV?
```

Because "FILE:LOAD:SETup:EXECute "CASE1"" is an overlapped command, the oscilloscope will advance to the "CHANnel1:VDIV?" command before it finishes the load. The returned V/div value will not show the newest setting, but will rather show the setting in use before the setup was changed.

Obviously, use of overlapped commands may in some cases produce inappropriate results. Where necessary, you can avoid such problems as described below.

Synchronization with an Overlap Command

Using the *WAI Command

The *WAI command causes the commands which follow it to wait until an overlap command has been executed.

```
Example :COMMunicate:OPSE #0040;:FILE:  
LOAD:SETup:EXECute "CASE1";  
*WAI;:CHANnel1:VDIV?<PMT>
```

The "COMMunicate:OPSE" command is used to designate which commands are to be subject to the *WAI command. In the above example, only auto setup is designated.

Since a *WAI command is executed just before "CHANnel1:VDIV?," "CHANnel1:VDIV?" will not be executed until auto setup has been completed.

Using the COMMunicate:OVERlap Command

The "COMMunicate:OVERlap" command is used to enable or disable overlap operation.

```
Example :COMMunicate:OVERlap #HFFBF;:  
FILE:LOAD:SETup:  
EXECute "CASE1";:CHANnel1:VDIV:  
VALue?<PMT>
```

The "COMMunicate:OVERlap #HFFBF" command disables overlapped operation of the medium access command, while enabling all other overlap-type operations. The oscilloscope will therefore handle "FILE:LOAD:SETup:EXECute "CASE1"" as sequential command, ensuring that the "CHANnel1:VDIV?" command (in the above example) will not execute until file loading is completed.

Using the *OPC Command

The *OPC command causes the OPC bit (bit 0) of the standard event register (page 6-4) to be set to "1" when an overlap operation has been completed.

```
Example :COMMunicate:OPSE #H0040;*ESE 1;  
*ESR?;*SRE 32;:FILE:LOAD:SETup:  
EXECute "CASE1";*OPC<PMT>  
(Response to *ESR? is decoded.)  
(Service request is awaited.)  
CHANnel1:VDIV?<PMT>
```

The "COMMunicate:OPSE" command is used to designate which commands are to be subject to the *OPC command. In the above example, only medium access commands are designated.

*ESE 1 and *SRE 32 stipulate that a service request is generated only when the OPC bit is set to "1." *ESR? is used to clear the standard event register.

In the above example, "CHANnel1:VDIV?" will not be executed until a service request is generated.

Using the *OPC? Query

The *OPC? query generates a response when an overlap operation has been completed.

```
Example :COMMunicate:OPSE #H0040;:FILE:
        LOAD:SETup:EXECute "CASE1";
        *OPC?<PMT>
        (Response to *OPC? is decoded.)
        :CHANnel1:VDIV?<PMT>
```

The "COMMunicate:OPSE" command is used to designate which commands are to be subject to the *OPC? command. In the above example, only medium access commands are designated.

Since *OPC? does not generate a response until an overlap operation is completed, file loading will have been completed when a response to *OPC? is read.

Note

Most commands are sequential commands. Commands used in Chapter 6 are sequential commands unless otherwise specified.

Synchronization with Non-Overlap Commands

Synchronization is sometimes required for reasons other than communications-related reasons, such as the activation of a trigger, even if a sequential command is used.

For example, if a "next program" message is transmitted to make an inquiry about the waveform data which has been acquired using single mode as the trigger mode, the "WAVEform:SEND?" command is sometimes executed whether acquisition has been completed or not, causing a command execution error.

```
:TRIGger:MODE SINGLE;:START;:WAVEform:
SEND?<PMT>
```

In this case, synchronization with the time at which acquisition is completed must be accomplished, as shown next.

Using STATUS:CONDITION? Query

A "STATUS:CONDITION?" query is used to make an inquiry about the contents of the condition register (page 6-4). It is possible to judge whether acquisition is in progress or not by reading bit 0 of the condition register. Bit 0 is "1" if acquisition is in progress, and "0" if acquisition is stopped.

```
Example :TRIGger:MODE SINGLE;:START<PMT>
        :STATus:CONDition?<PMT>
        (Returns to the previous status if bit 0 is
        found to be "1" when the response is
        decoded.)
        :WAVEform:SEND?<PMT>
```

A "WAVEform:SEND?" query will not be executed until bit 0 of the condition register has been set to "0."

Using the Extended Event Register

Changes in the condition register are reflected in the extended event register (page 6-4).

```
Example :STATus:FILTer1
        FALL;:STATus:EESR 1;EESR?;
        *SRE 8;:TRIGger:MODE SINGLE;:
        START<PMT>
        (Response to "STATus:EESR?" is
        decoded.)
        (Service request is awaited.)
        :WAVEform:SEND?<PMT>
```

The "STATus:FILTer1 FALL" command sets the transition filter such that Bit 0 (FILTer1) of the Extended Event Register sets to 1 when Bit 0 of the Condition Register changes from 1 to 0.

"STATus:EESR 1" is a command used only to reflect the status of bit 0 of the extended event register in the status byte.

"STATus:EESR?" is used to clear the extended event register.

The *SRE command is used to generate a service request caused solely by the extended event register. "WAVEform:SEND?" will not be executed until a service request is generated.

Using the COMMunicate:WAIT Command

The "COMMunicate:WAIT" command halts communications until a specific event is generated.

```
Example :STATus:FILTer1 FALL;:STATus:
        EESR?;:TRIGger:MODE SINGLE;:
        START<PMT>
        (Response to "STATus:EESR?" is
        decoded.)
        :COMMunicate:WAIT 1;:WAVEform:
        SEND?<PMT>
```

For a description of "STATus:FILTer1 FALL" and "STATus:EESR?," refer to "Using the extended event register" on this page.

"COMMunicate:WAIT 1" means that communications is halted until bit 0 of the extended event register is set to "1."

Chapter 5 Commands

5.1 A List of Commands

Command	Function	Page
ACQUIRE Group		
:ACQUIRE?	Queries all settings related to waveform acquisition.	5-16
:ACQUIRE:AVERAGE?	Queries all settings related to averaging.	5-16
:ACQUIRE:AVERAGE:COUNT	Sets the number of waveform acquisitions during averaging or queries the current setting.	5-16
:ACQUIRE:AVERAGE:EWEIGHT	Sets the attenuation constant for exponential averaging or queries the current setting.	5-16
:ACQUIRE:CLOCK	Sets the time base or queries the current setting.	5-16
:ACQUIRE:COUNT	Sets the number of waveform acquisitions during normal mode, average mode, and box average or queries the current setting.	5-16
:ACQUIRE:INTERLEAVE	Turns the interleave mode ON/OFF or queries the current setting.	5-16
:ACQUIRE:MODE	Sets the waveform acquisition mode or queries the current setting.	5-16
:ACQUIRE:REPETITIVE	Turns the repetitive sampling mode ON/OFF or queries the current setting.	5-16
:ACQUIRE:RENGTH	Sets the record length or queries the current setting.	5-16
ASETUP Group		
:ASETUP:EXECUTE	Executes auto setup.	5-17
:ASETUP:UNDO	Cancel the previous auto setup operation.	5-17
CALIBRATE Group		
:CALIBRATE?	Queries all settings related to calibration.	5-17
:CALIBRATE:DESKEW?	Queries all settings related to skew compensation.	5-17
:CALIBRATE:DESKEW:MODE	Turns the skew compensation ON/OFF or queries the current setting.	5-17
:CALIBRATE:DESKEW:TARGET	Sets the channel on which skew compensation is to be performed or queries the current setting.	5-17
:CALIBRATE:DESKEW:TIME	Sets the skew adjustment time that are common to all channels or queries the current setting.	5-17
:CALIBRATE[:EXECUTE]	Executes the calibration.	5-18
:CALIBRATE:MODE	Turns auto calibration ON/OFF or queries the current setting.	5-18
CHANNEL Group		
:CHANNEL<x>?	Queries all settings related to the vertical axis of the channel.	5-20
:CHANNEL<x>:BWIDTH	Sets the input filter of the channel or queries the current setting.	5-20
:CHANNEL<x>:COUPLING	Sets the input coupling of the channel or queries the current setting.	5-20
:CHANNEL<x>:DISPLAY	Turns ON/OFF the channel or queries the current setting.	5-20
:CHANNEL<x>:LABEL	Sets the waveform label of channel or queries the current setting.	5-20
:CHANNEL<x>:LSCALE?	Queries all settings related to the linear scaling of the channel.	5-20
:CHANNEL<x>:LSCALE:AVALUE	Sets scaling coefficient A or queries the current setting.	5-20
:CHANNEL<x>:LSCALE:BVALUE	Sets offset value B or queries the current setting.	5-20
:CHANNEL<x>:LSCALE:MODE	Turns ON/OFF the linear scaling or queries the current setting.	5-20
:CHANNEL<x>:LSCALE:UNIT	Sets the unit of the value after it is scaled or queries the current setting.	5-20
:CHANNEL<x>:MODE	Turns ON/OFF the display of the channel or queries the current setting.	5-21
:CHANNEL<x>:OFFSET	Sets the offset voltage of the channel or queries the current setting.	5-21
:CHANNEL<x>:POSITION	Sets the vertical position of the channel or queries the current setting.	5-21
:CHANNEL<x>:PROBE	Sets the probe attenuation/current-to-voltage conversion ratio of the channel or queries the current setting.	5-21
:CHANNEL<x>:VARIABLE	Sets the voltage sensitivity of the channel in 0.01 steps of the V/div setting or queries the current setting.	5-21
:CHANNEL<x>:VDIV	Sets the voltage sensitivity (V/div) of the channel or queries the current setting.	5-21
CLEAR Group		
:CLEAR	Clears the trace.	5-22
COMMUNICATE Group		
:COMMUNICATE?	Queries all settings related to communications.	5-23
:COMMUNICATE:HEADER	Sets whether or not to add a header to the response data or queries the current setting.	5-23
:COMMUNICATE:LOCKOUT	Sets or clears the local lockout.	5-23
:COMMUNICATE:OPSE	Sets the overlap commands that are subject to *OPC, *OPC?, and *WAI or queries the current setting.	5-24
:COMMUNICATE:OPSR?	Queries the operation pending status register value.	5-24

5.1 A List of Commands

Command	Function	Page
:COMMunicate:OVERlap	Sets the commands that will operate as overlap commands or queries the current setting.	5-24
:COMMunicate:REMOte	Switches to remote/local mode.	5-24
:COMMunicate:STATus?	Queries the line status.	5-24
:COMMunicate:VERBoSe	Sets the response messages to full form or abbreviated form or queries the current setting.	5-24
:COMMunicate:WAIT	Waits for a specified extended event.	5-24
:COMMunicate:WAIT?	Creates a response that is returned when the specified event occurs.	5-24
CURSOR Group		
:CURSor?	Queries all settings related to cursor measurements.	5-27
:CURSor:TY?	Queries all settings related to the cursor in the T-Y display.	5-27
:CURSor:TY:DEGRee?	Queries all settings related to angle cursors.	5-27
:CURSor:TY:DEGRee:DX?	Queries the angle difference, ΔD , between angle cursors.	5-27
:CURSor:TY:DEGRee:DY?	Queries the angle difference, ΔV , between angle cursors.	5-27
:CURSor:TY:DEGRee:JUMP	Moves the angle cursor to the zoomed waveform.	5-27
:CURSor:TY:DEGRee:POSition<x>	Sets the position of the angle cursor or queries the current setting.	5-27
:CURSor:TY:DEGRee:REFerence<x>	Sets the position of the zero point (Reference 1) or the end point (Reference 2) that will be used as a reference in the angle cursor measurement or queries the current setting.	5-27
:CURSor:TY:DEGRee:RVALue	Sets the reference angle of the angle cursor or queries the current setting.	5-27
:CURSor:TY:DEGRee:TRACe	Sets the waveform on which to use the angle cursor or queries the current setting.	5-28
:CURSor:TY:DEGRee:X<x>?	Queries the angle at the angle cursor.	5-28
:CURSor:TY:DEGRee:Y<x>?	Queries the voltage value at the angle cursor.	5-28
:CURSor:TY:HORizontal?	Queries all settings related to horizontal cursors.	5-28
:CURSor:TY:HORizontal:DY?	Queries the Y-axis value between the horizontal cursors.	5-28
:CURSor:TY:HORizontal:POSition<x>	Sets the horizontal cursor position or queries the current setting.	5-28
:CURSor:TY:HORizontal:TRACe	Sets the waveform on which to use the horizontal cursor or queries the current setting.	5-28
:CURSor:TY:HORizontal:Y<x>?	Queries the Y-axis value of the horizontal cursor.	5-28
:CURSor:TY:MARKer?	Queries all settings related to marker cursors.	5-28
:CURSor:TY:MARKer:DX<x>?	Queries the X-axis value between the marker cursors.	5-29
:CURSor:TY:MARKer:DY<x>?	Queries the physical value of the Y-axis difference between the marker cursors.	5-29
:CURSor:TY:MARKer:M<x>?	Queries all settings related to the specified marker cursor.	5-29
:CURSor:TY:MARKer:M<x>:JUMP	Jumps the marker cursor onto the zoom waveform display frame.	5-29
:CURSor:TY:MARKer:M<x>:POSition<x>	Sets the X-axis position of the marker cursor or queries the current setting.	5-29
:CURSor:TY:MARKer:M<x>:TRACe	Sets the waveform on which to use the marker cursor or queries the current setting.	5-29
:CURSor:TY:MARKer:X<x>?	Queries the X-axis position of the marker cursor.	5-29
:CURSor:TY:MARKer:Y<x>?	Queries the Y-axis position of the marker cursor.	5-29
:CURSor:TY:TYPE	Sets the cursor type or queries the current setting.	5-29
:CURSor:TY:VERTical?	Queries all settings related to vertical cursors.	5-29
:CURSor:TY:VERTical:DX?	Queries the X-axis value between vertical cursors.	5-30
:CURSor:TY:VERTical:DY?	Queries the Y-axis value between vertical cursors.	5-30
:CURSor:TY:VERTical:JUMP	Moves the vertical cursor to the zoomed waveform.	5-30
:CURSor:TY:VERTical:PERDt?	Queries the $1/\Delta T$ value between vertical cursors.	5-30
:CURSor:TY:VERTical:POSition<x>	Sets the vertical cursor position or queries the current setting.	5-30
:CURSor:TY:VERTical:TRACe	Sets the waveform on which to use the vertical cursor or queries the current setting.	5-30
:CURSor:TY:VERTical:X<x>?	Queries the X-axis position of the vertical cursor.	5-30
:CURSor:TY:VERTical:Y<x>?	Queries the Y-axis position of the vertical cursor.	5-30
:CURSor:XY?	Queries all settings related to the cursors in the X-Y display.	5-30
:CURSor:XY:HORizontal?	Queries all settings related to the horizontal cursors in the X-Y display.	5-30
:CURSor:XY:HORizontal:DY?	Queries the Y-axis value of the horizontal cursor of the X-Y display.	5-30
:CURSor:XY:HORizontal:POSition<x>	Sets the horizontal cursor position of the X-Y display or queries the current setting.	5-31
:CURSor:XY:HORizontal:TRACe	Sets the waveform on which to use the horizontal cursor in the X-Y display or queries the current setting (DL1740E/DL1740EL only).	5-31
:CURSor:XY:HORizontal:Y?	Queries the Y-axis value of the horizontal cursor of the X-Y display.	5-31
:CURSor:XY:MARKer?	Queries all settings related to the marker cursors in the X-Y display.	5-31
:CURSor:XY:MARKer:POSition	Sets the X-axis position of the marker cursor in the X-Y display or queries the current setting.	5-31
:CURSor:XY:MARKer:T?	Queries the time value of the marker cursor in the X-Y display.	5-31
:CURSor:XY:MARKer:TRACe	Sets the waveform on which to use the marker cursor in the X-Y display or queries the current setting (DL1740E/DL1740EL only).	5-31

Command	Function	Page
:CURSor:XY:MARKer:X?	Queries the X-axis position of the marker cursor in the X-Y display.	5-31
:CURSor:XY:MARKer:Y?	Queries the Y-axis position of the marker cursor in the X-Y display.	5-31
:CURSor:XY:TYPE	Sets the cursor type of the X-Y display or queries the current setting.	5-31
:CURSor:XY:VERTical?	Queries all settings related to vertical cursors in the X-Y display.	5-31
:CURSor:XY:VERTical:DX?	Queries the X-axis value between the vertical cursors in the X-Y display.	5-31
:CURSor:XY:VERTical:POSition<x>	Sets the vertical cursor position of the X-Y display or queries the current setting.	5-31
:CURSor:XY:VERTical:TRACe	Sets the waveform on which to use the vertical cursor in the X-Y display or queries the current setting (DL1740E/DL1740EL only).	5-32
:CURSor:XY:VERTical:X<x>?	Queries the X-axis position of the vertical cursor in the X-Y display.	5-32
DISPlay Group		
:DISPlay?	Queries all settings related to the display.	5-35
:DISPlay:ACCumulate?	Queries all settings related to the accumulation display.	5-35
:DISPlay:ACCumulate:COLor	Sets the color grade width or queries the current setting.	5-35
:DISPlay:ACCumulate:MODE	Sets the accumulation mode or queries the current setting.	5-35
:DISPlay:ACCumulate:PERSistence	Sets the accumulation time or queries the current setting.	5-35
:DISPlay:COLor	Sets whether to change the screen color using RGB or brightness or queries the current setting.	5-35
:DISPlay:RGB?	Queries all settings related to the screen color.	5-35
:DISPlay:RGB:MENU?	Queries all settings related to colors used in the menu.	5-35
:DISPlay:RGB:MENU:{BACK DIALog FOCUS FORE LINE SELEct SHADow}	Sets the color of the characters, background, dialog, and lines of the menu screen or queries the current setting.	5-35
:DISPlay:RGB:OTHerS?	Queries all settings related to the colors of other items.	5-35
:DISPlay:RGB:OTHerS:{CURSor GRID MARKer SNAP ZONE<x>}	Sets the color for cursors, grid, markers, and snapshot waveforms or queries the current setting.	5-36
:DISPlay:RGB:WAVeform?	Queries all settings related to the waveform colors.	5-36
:DISPlay:RGB:WAVeform:{CHANnel<x> BACK MATH<x>}	Sets the colors for waveform and computation channels or queries the current setting.	5-36
:DISPlay:FORMat	Sets the display format or queries the current setting.	5-36
:DISPlay:GRATicule	Sets the graticule type or queries the current setting.	5-36
:DISPlay:INTENsity?	Queries all settings related to the brightness of the displayed items.	5-36
:DISPlay:INTENsity:{CURSor MENU GRID SNAP WAVeform}	Sets the brightness of each display item or queries the current setting.	5-36
:DISPlay:INTERpolate	Sets the interpolation method or queries the current setting.	5-36
:DISPlay:MAPPING	Sets the mapping mode used to allocate the waveforms to the divided windows or queries the current setting.	5-36
:DISPlay:SMAPPING?	Queries the mapping of all waveforms to the divided windows.	5-36
:DISPlay:SMAPPING:{CHANnel<x> MATH<x>}	Maps waveforms to the divided windows or queries the current setting.	5-37
:DISPlay:SVALue	Turns the scale value display ON/OFF or queries the current setting.	5-37
:DISPlay:TlABEL	Turns the display of waveform labels ON/OFF or queries the current setting.	5-37
:DISPlay:TRANslucent	Turns the popup menu's transparent mode ON/OFF or queries the current setting.	5-37
FILE Group		
:FILE?	Queries all settings related to the specified storage medium.	5-41
:FILE:DELEte:{ASCIi BINary BMP FLOat JPEG MEASure PNG POSTscript SETup SNAP TIFF}:[:EXECute]	Deletes various types of data files.	5-41
:FILE:DIRectory?	Queries all settings related to the specified directory.	5-41
:FILE[:DIRectory]:CDIRectory	Changes the target directory.	5-41
:FILE[:DIRectory]:DRIVE	Sets the specified storage medium.	5-41
:FILE[:DIRectory]:FILTer	Sets the filter (limits the target files) or queries the current setting.	5-41
:FILE[:DIRectory]:FREE?	Queries the free disk space (bytes) on the specified storage medium.	5-41
:FILE[:DIRectory]:MDIRectory	Creates a directory under the specified directory.	5-41
:FILE[:DIRectory]:PATH?	Queries the specified directory.	5-41
:FILE:FORMat:EXECute	Formats the floppy disk or PC card.	5-41
:FILE:LOAD?	Queries all settings related to file loading.	5-41
:FILE:LOAD:{BINary SETup SNAP}:ABORt	Aborts loading the data.	5-41
:FILE:LOAD:{BINary SETup SNAP}[:EXECute]	Loads the data.	5-41
:FILE:LOAD:SNAP?	Queries all settings related to the loading of the snapshot waveform data.	5-41

5.1 A List of Commands

Command	Function	Page
:FILE:LOAD:SNAP:PLANE	Sets the plane number of the snapshot waveform data (Snap1 to 4) or queries the current setting.	5-42
:FILE:SAVE?	Queries all settings related to saving.	5-42
:FILE:SAVE:ANAMING	Turns ON/OFF the auto naming function of file names of the saved data or queries the current setting.	5-42
:FILE:SAVE:{ASCIi BINary FLOat}?	Queries all settings related to various types of data.	5-42
:FILE:SAVE:{ASCIi BINary FLOat MEASure SETup SNAP}:ABORT	Aborts saving the various types of data.	5-42
:FILE:SAVE:{ASCIi BINary FLOat MEASure SETup SNAP}[:EXECute]	Executes the data save operation.	5-42
:FILE:SAVE:{ASCIi BINary FLOat}:HISTory	Sets whether to save all the waveform data or a selected waveform or queries the current setting.	5-42
:FILE:SAVE:{ASCIi BINary FLOat}:RANGe	Sets the range of data to be saved or queries the current setting.	5-42
:FILE:SAVE:{ASCIi BINary FLOat}:TRACe	Sets the waveform to be saved or queries the current setting.	5-42
:FILE:SAVE:BINary:COMPRESSion	Sets P-P compression for saving the waveform data or queries the current setting.	5-42
:FILE:SAVE:COMMENT	Sets comments or queries the current setting.	5-42
:FILE:SAVE:NAME	Sets the name of the data file to be saved or queries the current setting.	5-43
:FILE:UNLoad?	Queries all settings related to canceling the loaded data.	5-43
:FILE:UNLoad:{BINary SNAP}?	Queries all setting related to the unloading of various data that has been loaded.	5-43
:FILE:UNLoad:{BINary SNAP}[:EXECute]	Executes the unloading of the various data that has been loaded.	5-43
:FILE:UNLoad:BINary:TRACe	Of the binary data that has been loaded, sets the waveform to be unloaded or queries the current setting.	5-43
:FILE:UNLoad:SNAP:PLANE	Of the snapshot waveform that has been loaded, sets the plane number to be unloaded or queries the current setting.	5-43
GONogo Group		
:GONogo?	Queries all settings related to GO/NO-GO determination.	5-47
:GONogo:ABORT	Aborts GO/NO-GO determination.	5-47
:GONogo:ACTion?	Queries all settings related to the action to be performed when the result of the determination is NO-GO and also the determination criteria.	5-47
:GONogo:ACTion:BUZZer	Sets whether or not to sound an alarm when the determination is NO-GO or queries the current setting.	5-47
:GONogo:ACTion:HCOPY	Sets whether to print the screen image to the built-in printer (optional) during NO-GO determination or queries the current setting.	5-47
:GONogo:ACTion:IMAGe	Sets whether or not to save the screen image to the external storage medium for NO-GO determination or queries the current setting.	5-47
:GONogo:ACTion:MAIL?	Queries all setting values for mail reports sent when NO-GO is determined.	5-47
:GONogo:ACTion:MAIL:COUNT	Sets/queries the maximum number of e-mail is to be sent when the determination is NO-GO.	5-47
:GONogo:ACTion:MAIL:MODE	Sets/queries whether and e-mail report is sent when the determination is NO-GO.	5-47
:GONogo:ACTion:SAVE	Sets whether or not to save the NO-GO result to the storage medium or queries the current setting.	5-47
:GONogo:COUNT?	Queries the GO/NO-GO determination count.	5-48
:GONogo:EXECute	Executes GO/NO-GO determination.	5-48
:GONogo:LOGic	Sets the GO/NO-GO determination logic or queries the current setting.	5-48
:GONogo:MODE	Sets the GO/NO-GO determination type or queries the current setting.	5-48
:GONogo:NGCount?	Queries the number of NO-GO results.	5-48
:GONogo:PARAMeter?	Queries all settings related to the waveform parameter determination.	5-48
:GONogo:PARAMeter:ITEM<x>?	Queries all settings related to waveform parameters.	5-48
:GONogo:PARAMeter:ITEM<x>:CAUSE?	Queries whether or not the waveform parameter is the cause of the NO-GO result.	5-48
:GONogo:PARAMeter:ITEM<x>:CONDition	Sets the criteria of the waveform parameters on which GO/NO-GO determination is to be performed or queries the current setting.	5-48
:GONogo:PARAMeter:ITEM<x>:MODE	Turns ON/OFF the waveform parameters on which GO/NO-GO determination is to be performed or queries the current setting.	5-48
:GONogo:PARAMeter:ITEM<x>:TRACe	Sets the target waveform of the waveform parameters on which GO/NO-GO determination is to be performed or queries the current setting.	5-48
:GONogo:PARAMeter:ITEM<x>:TYPE?	Queries the automated measurement parameters and the upper and lower limits of the waveform parameters on which GO/NO-GO determination is to be performed.	5-48

Command	Function	Page
:GONogo:PARAMeter:ITEM<x>:TYPE:<parameter>	Sets the upper and lower limits of the automated measurement parameter of the specified waveform parameter on which GO/NO-GO determination is to be performed or queries the current setting.	5-49
:GONogo:PARAMeter:ITEM<x>:VALue?	Queries the automated measurement values of the waveform parameters on which GO/NO-GO determination is to be performed.	5-49
:GONogo:SEquence	Selects single or continuous action or queries the current setting.	5-49
:GONogo:STOPcount	Sets the number of waveform acquisitions on which to perform GO/NO-GO determination or queries the current setting.	5-49
:GONogo:TLINKage	Turns ON/OFF the linked movement of the determination range cursor of the GO/NO-GO determination.	5-49
:GONogo:TRANge	Sets the range over which to perform GO/NO-GO determination or queries the current setting.	5-49
:GONogo:WAIT?	Waits for the GO/NO-GO determination to complete with a timeout.	5-49
:GONogo:ZONE?	Queries all settings related to GO/NO-GO determination using zones.	5-49
:GONogo:ZONE:EDIT<x>:EXIT	Exits from the edit menu of the zone for GO/NO-GO determination using zones.	5-50
:GONogo:ZONE:EDIT<x>:PART	Edits a portion of the zone for GO/NO-GO determination using zones.	5-50
:GONogo:ZONE:EDIT<x>:WHOLe	Edits the zone for GO/NO-GO determination using zones.	5-50
:GONogo:ZONE:ZONE<x>?	Queries all settings related to GO/NO-GO determination using zones. of the specified zone.	5-50
:GONogo:ZONE:ZONE<x>:CAUSE?	Queries whether or not the specified zone for GO/NO-GO determination using zones. is the cause of the NO-GO result.	5-50
:GONogo:ZONE:ZONE<x>:CONDition	Sets the criteria for the zone for GO/NO-GO determination using zones. or queries the current setting.	5-50
:GONogo:ZONE:ZONE<x>:MODE	Turns ON/OFF the GO/NO-GO determination of the zone or queries the current setting.	5-50
:GONogo:ZONE:ZONE<x>:SEND	Sets the zone data specified for the GO/NO-GO determination zone or queries the current setting.	5-51
:GONogo:ZONE:ZONE<x>:TRACe	Sets the target trace of the zone for GO/NO-GO determination using zones or queries the current setting.	5-51
HCOPY Group		
:HCOPY?	Queries all settings related to the print of the screen image data.	5-53
:HCOPY:ABORt	Aborts printing or paper feeding.	5-53
:HCOPY:COMMeNt	Sets comments at the lower section of the screen or queries the current setting.	5-53
:HCOPY:DIReCtion	Sets the printer or queries the current setting.	5-53
:HCOPY:EXECute	Executes the print operation.	5-53
:HCOPY:EXTPrINter?	Queries all settings related to printing when using an external printer.	5-53
:HCOPY:EXTPrINter:PRINter?	Queries the addresses of the printers that are currently connected.	5-53
:HCOPY:EXTPrINter:SElect	Sets the specified printer address or queries the current setting.	5-53
:HCOPY:EXTPrINter:TONE	Sets the half tone when printing using an external printer or queries the current setting.	5-54
:HCOPY:EXTPrINter:TYPE	Sets the type of output commands to send to the external printer or queries the current setting.	5-54
:HCOPY:NETPrINt?	Queries all settings related to printing using a network printer.	5-54
:HCOPY:NETPrINt:TONE	Sets the half tone when printing using a network printer or queries the current setting.	5-54
:HCOPY:NETPrINt:TYPE	Sets the printer description language sent to the network printer or the type of printer or queries the current setting.	5-54
:HCOPY:PRINter?	Queries all settings related to printing when using the built-in printer.	5-54
:HCOPY:PRINter:MAG	Sets the magnification for long print or queries the current setting.	5-54
:HCOPY:PRINter:RANGe	Sets the print range for long print or queries the current setting.	5-54
:HCOPY:PRINter:REPort	Sets whether to print additional information when printing to the built-in printer or queries the current setting.	5-54
:HCOPY:PRINter:TLINKage	Turns ON/OFF the linked movement of the print range cursors for long print using the built-in printer or queries the current setting.	5-54
:HCOPY:PRINter:TYPE	Sets short print or long print when printing to the built-in printer or queries the current setting.	5-54
HISTory Group		
:HISTory?	Queries all settings related to the history memory function.	5-57
:HISTory:ABORt	Aborts the history search.	5-57
:HISTory:DISPlay	Sets the start number or end number of the display record of the history memory waveform or queries the current setting.	5-57
:HISTory:EXECute	Executes the history search.	5-57

5.1 A List of Commands

Command	Function	Page
:HISTory:DMODE	Sets the display mode of the history memory waveform or queries the current setting.	5-57
:HISTory:PARAMeter?	Queries all settings related to the history search (waveform parameter).	5-57
:HISTory:PARAMeter:ITEM<x>?	Queries all settings related to the waveform parameter of the history search (waveform parameter).	5-57
:HISTory:PARAMeter:ITEM<x>:CONDition	Sets the criteria of the waveform parameter of the history search (waveform parameter) or queries the current setting.	5-57
:HISTory:PARAMeter:ITEM<x>:SOURce	Sets the target waveform of the waveform parameter of the history search (waveform parameter) or queries the current setting.	5-58
:HISTory:PARAMeter:ITEM<x>:TYPE:<Parameter>	Sets the automated measurement parameter and its upper and lower limits of the waveform parameter of the history search (waveform parameter) or queries the current setting.	5-58
:HISTory:PARAMeter:ITEM<x>:VALue?	Queries the automated measurement value of the waveform parameter of the history search (waveform parameter).	5-58
:HISTory:PARAMeter:LOGic	Sets the search logic of the history search (waveform parameter) or queries the current setting.	5-58
:HISTory:PARAMeter:TlINKage	Turns ON/OFF the linked movement of the determination range cursor of the history search (waveform parameter) or queries the current setting.	5-58
:HISTory:PARAMeter:TRANge	Sets the determination range of the history search (waveform parameter) or queries the current setting.	5-58
:HISTory:RECOrd	Sets the target record of the history memory waveform or queries the current setting.	5-58
:HISTory:RECOrd? MINimum	Queries the minimum record number.	5-58
:HISTory:SMODE	Sets the search mode of the history memory waveform or queries the current setting.	5-58
:HISTory:TIME?	Queries the time of the target record number of the history memory waveform.	5-59
:HISTory:ZONE?	Queries all settings related to the history search (zone).	5-59
:HISTory:ZONE:EDIT<x>?	Queries all settings related to the search zone of the history search (zone).	5-59
:HISTory:ZONE:EDIT<x>:CONDition	Sets the search condition of the history search (zone) or queries the current setting.	5-59
:HISTory:ZONE:EDIT<x>:HORizontal	Sets the horizontal position of the zone of the history search (zone) or queries the current setting.	5-59
:HISTory:ZONE:EDIT<x>:SOURce	Sets the target waveform of the history search (zone) or queries the current setting.	5-59
:HISTory:ZONE:EDIT<x>:VERTical	Sets the vertical position of the zone of the history search (zone) or queries the current setting.	5-59
:HISTory:ZONE:LOGic	Sets the search logic condition of the history search (zone) or queries the current setting.	5-59
IMAGe Group		
:IMAGe?	Queries all settings related to the screen image data save.	5-61
:IMAGe:ABORt	Aborts saving the screen image data to the storage medium.	5-61
:IMAGe:COMMeNt	Sets the comment on the screen or queries the current setting.	5-61
:IMAGe:COMPreSSion	Sets the screen image data compression of the TIFF format or queries the current setting.	5-61
:IMAGe:EXECute	Saves the screen image data to the storage medium.	5-61
:IMAGe:FORMat	Sets the save format of the screen image data or queries the current setting.	5-61
:IMAGe:SAVE?	Queries all settings related to the save operation of the screen image data to the storage medium.	5-61
:IMAGe:SAVE:ANAMing	Turns ON/OFF the auto naming function of file names or queries the current setting.	5-61
:IMAGe:SAVE:CDIRectory	Changes the directory in which to save the screen image data.	5-61
:IMAGe:SAVE:DRIVE	Sets the storage medium for the file used to save the screen image data.	5-61
:IMAGe:SAVE:NAME	Sets the name of the file to be saved or queries the current setting.	5-61
:IMAGe:SEND?	Queries the screen image data.	5-61
:IMAGe:TONE	Sets the color tone of the saving screen image data or queries the current setting.	5-61
INITialize Group		
:INITialize:EXECute	Executes initialization.	5-62
:INITialize:UNDO	Cancels the initialization that was executed.	5-62

Command	Function	Page
MATH Group		
:MATH<x>?	Queries all settings related to computations.	5-64
:MATH<x>:BINary?	Queries all settings related to binary computations.	5-64
:MATH<x>:BINary:{CHANnel<x> MATH1}	Sets the threshold levels of the channel for binary computation or queries the current setting.	5-64
:MATH<x>:DISPlay	Sets whether or not to display computation waveforms or queries the current setting.	5-64
:MATH<x>:FFT?	Queries all settings related to the FFT.	5-64
:MATH<x>:FFT:POINTs	Sets the number of points for the FFT or queries the current setting.	5-64
:MATH<x>:FFT:SPOint	Sets the start point of the FFT or queries the current setting.	5-64
:MATH<x>:FFT:WINDow	Sets the window function of the FFT or queries the current setting.	5-64
:MATH<x>:INTEgral?	Queries all settings related to integration.	5-64
:MATH<x>:INTEgral:SPOint	Sets the start point of the integration or queries the current setting.	5-64
:MATH<x>:LABel	Sets the label of the computation waveform or queries the current setting.	5-65
:MATH<x>:OPERation	Sets the type of computation or queries the current setting.	5-65
:MATH<x>:SCALE?	Queries all settings related to the scale conversion for normal computation.	5-65
:MATH<x>:SCALE:CENTer	Sets the center value of the scale conversion for normal computation or queries the current setting.	5-65
:MATH<x>:SCALE:MODE	Sets the scale conversion method for normal computation or queries the current setting.	5-65
:MATH<x>:SCALE:SENSitivity	Sets the span from the center of the scale conversion for normal computation or queries the current setting.	5-65
:MATH<x>:SMOothing	Turns smoothing ON/OFF for normal computation or queries the current setting.	5-65
:MATH<x>:UNIT	Sets the unit to be added to the computed result for normal computation or queries the current setting.	5-65
MEASure Group		
:MEASure?	Queries all settings related to the automated measurement of waveform parameters.	5-69
:MEASure:AMODE	Sets the normal automated measurement of parameters (NORMal) and the automated measurement of parameters on dual areas (AREA2) or queries the current setting.	5-70
:MEASure:{CHANnel<x> MATH<x>}?	Queries the ON/OFF state of every parameter of the waveform.	5-71
:MEASure:{CHANnel<x> MATH<x>}:ALL	Turns ON/OFF collectively the automated measurement parameters of all waveform parameters of the waveform.	5-71
:MEASure:{CHANnel<x> MATH<x>}:COPY	Copies the ON/OFF setting of the automated measurement parameters of waveform parameters of the specified waveform to all other waveforms.	5-71
:MEASure:{CHANnel<x> MATH<x>}:DELAy?	Queries all settings related to the delay between waveforms.	5-71
:MEASure:{CHANnel<x> MATH<x>}:DELAy:MEASure?	Queries all settings of the measured waveform in the delay measurement between waveforms.	5-71
:MEASure:{CHANnel<x> MATH<x>}:DELAy:MEASure:COUNT	Sets the edge detection count of the measured waveform in the delay measurement between waveforms or queries the current setting.	5-71
:MEASure:{CHANnel<x> MATH<x>}:DELAy:MEASure:SLOPe	Sets the slope of the measured waveform in the delay measurement between waveforms or queries the current setting.	5-71
:MEASure:{CHANnel<x> MATH<x>}:DELAy:REFereNce?	Queries all settings of the reference waveform in the delay measurement between waveforms.	5-72
:MEASure:{CHANnel<x> MATH<x>}:DELAy:REFereNce:COUNT	Sets the edge detection count of the reference waveform in the delay measurement between waveforms or queries the current setting.	5-72
:MEASure:{CHANnel<x> MATH<x>}:DELAy:REFereNce:SLOPe	Sets the slope of the reference waveform in the delay measurement between waveforms or queries the current setting.	5-72
:MEASure:{CHANnel<x> MATH<x>}:DELAy:REFereNce:SOURce	Sets the reference of the delay measurement between waveforms to the trigger point or the waveform or queries the current setting.	5-72
:MEASure:{CHANnel<x> MATH<x>}:DELAy:REFereNce:TRACe	Sets the trace of the reference waveform in the delay measurement between waveforms or queries the current setting.	5-72

5.1 A List of Commands

Command	Function	Page
:MEASure:{CHANnel<x> MATH<x>}:DElay:STATe	Sets the measurement mode of the delay measurement between waveforms or queries the current setting.	5-72
:MEASure:{CHANnel<x> MATH<x>}:DPRoximal?	Queries all settings related to distal, mesial, and proximal values of the automated measurement of waveform parameters.	5-73
:MEASure:{CHANnel<x> MATH<x>}:DPRoximal:MODE	Sets the unit of the distal, mesial, and proximal values of the automated measurement of waveform parameters or queries the current setting.	5-73
:MEASure:{CHANnel<x> MATH<x>}:DPRoximal:PERCent	Sets the distal, mesial, and proximal values of the automated measurement of waveform parameters in terms of a percentage or queries the current setting.	5-73
:MEASure:{CHANnel<x> MATH<x>}:DPRoximal:UNIT	Sets the distal, mesial, and proximal values of the automated measurement of waveform parameters in terms of a voltage or current or queries the current setting.	5-73
:MEASure:{CHANnel<x> MATH<x>}:METHod	Sets the high and low levels of the automated measurement of waveform parameters or queries the current setting.	5-73
:MEASure:{CHANnel<x> MATH<x>}:<parameter>?	Queries all settings related to the waveform parameters of each waveform.	5-73
:MEASure:{CHANnel<x> MATH<x>}:<parameter>:COUNT?	Queries the number of statistical processing of each waveform parameter.	5-74
:MEASure:{CHANnel<x> MATH<x>}:<parameter>:{MAXimum MEAN MINimum SDEVIation}?	Queries the statistics of each waveform parameter.	5-74
:MEASure:{CHANnel<x> MATH<x>}:<parameter>:STATe	Turns the waveform parameter ON/OFF or queries the current setting. (one by one)	5-74
:MEASure:{CHANnel<x> MATH<x>}:<parameter>:VALue?	Queries the value of the automated measurement of each waveform parameter.	5-74
:MEASure:CONSt<x>	Sets the constants to be used in the automated measurement of waveform parameters of Dual Area or queries the current setting.	5-75
:MEASure:CYCLe?	Queries all settings related to the periodic statistical processing of the automated measurement of waveform parameters (Cycle Statistics).	5-75
:MEASure:CYCLe:ABORt	Aborts the periodic statistical processing of the automated measurement of waveform parameters (Cycle Statistics).	5-75
:MEASure:CYCLe:EXECute	Executes the periodic statistical processing of the automated measurement of waveform parameters (Cycle Statistics).	5-75
:MEASure:CYCLe:TRACe	Sets the waveform used to determine the period for the periodic statistical processing of automated measurement of waveform parameters (Cycle Statistics) or queries the current setting.	5-75
:MEASure:HISTory:ABORt	Aborts the statistical processing within the historical data of the automated measurement of waveform parameters (History Statistics).	5-75
:MEASure:HISTory:EXECute	Executes the statistical processing within the historical data of the automated measurement of waveform parameters (History Statistics).	5-75
:MEASure:MODE	Sets the mode of the automated measurement of waveform parameters or queries the current setting.	5-75
:MEASure:ONECycle	Turns ON/OFF the automated measurement in the one-cycle mode or queries the current setting.	5-75
:MEASure:TlINKage<x>	Turns ON/OFF the linked movement of the cursors in the automated measurement of waveform parameters or queries the current setting.	5-75
:MEASure:TRANge<x>(Time Range)	Sets the measurement range of the automated measurement of waveform parameters or queries the current setting.	5-75
:MEASure:USER<x>?	Queries all settings related to the automated measurement of waveform parameters of the Dual Area.	5-76
:MEASure:USER<x>:AREA<y>?	Queries all settings related to the specified computation parameter/area of the automated measurement of waveform parameters of the Dual Area.	5-76
:MEASure:USER<x>:AREA<y>:ITEM	Sets the measurement item of the specified computation parameter/area of the automated measurement of waveform parameters of the Dual Area or queries the current setting.	5-76
:MEASure:USER<x>:AREA<y>:TRACe	Sets the measurement trace of the specified computation parameter/area of the automated measurement of waveform parameters of the Dual Area or queries the current setting.	5-76
:MEASure:USER<x>:COUNT?	Queries the statistical processing count of the automated measurement of waveform parameters of the Dual Area.	5-76

Command	Function	Page
:MEASure:USER<x>:{MAXimum? MEAN? MINimum? SDEviation?}	Queries the statistical value of the automated measurement of waveform parameters of the Dual Area.	5-76
:MEASure:USER<x>:OPERation	Sets the computing operation of the automated measurement of waveform parameters of the Dual Area or queries the current setting.	5-76
:MEASure:USER<x>:STATe	Turns ON/OFF the automated measurement of waveform parameters of the Dual Area or queries the current setting.	5-76
:MEASure:USER<x>:UNIT	Sets the display unit of the automated measurement of waveform parameters of the Dual Area or queries the current setting.	5-76
:MEASure:USER<x>:VALue?	Queries the measured value of the automated measurement of waveform parameters of the Dual Area.	5-77
:MEASure:WAIT?	Waits for the completion of the automated measurement of waveform parameters with a timeout option.	5-77
PHASe Group		
:PHASe?	Queries all settings related to the phase shift function.	5-78
:PHASe:CHANnel<x>	Sets the amount of phase shift of the waveform or queries the current setting.	5-78
:PHASe:MODE	Turns the phase shift function ON/OFF or queries the current setting.	5-78
PRESet Group		
:PRESet?	Queries all settings related to the preset function.	5-80
:PRESet:ALL:PROBE	Sets the preset value of the probe attenuation/current-to-voltage conversion ratio of all channels.	5-80
:PRESet:ALL:TYPE	Sets preset values to all channels.	5-80
:PRESet:ALL:USERdefine:LEVel	Sets the preset trigger level of all channels.	5-80
:PRESet:ALL:USERdefine:OFFSet	Sets the preset offset voltage of all channels.	5-80
:PRESet:ALL:USERdefine:VDIV	Sets the preset V/div value of all channels.	5-80
:PRESet:CHANnel<x>?	Queries the preset information of the specified channel.	5-80
:PRESet:CHANnel<x>:PROBE	Sets the preset value of the probe attenuation/current-to-voltage conversion ratio of the specified channel or queries the current setting.	5-80
:PRESet:CHANnel<x>:TYPE	Sets the specified preset or queries the current setting.	5-80
:PRESet:CHANnel<x>:USERdefine?	Queries all preset values when using user-type presets.	5-80
:PRESet:CHANnel<x>:USERdefine:LEVel	Sets the preset value of the user-type trigger level or queries the current setting.	5-80
:PRESet:CHANnel<x>:USERdefine:OFFSet	Sets the preset value of the user-type offset voltage or queries the current setting.	5-81
:PRESet:CHANnel<x>:USERdefine:VDIV	Sets the preset value of the user-type V/div value or queries the current setting.	5-81
:PRESet:EXECute	Executes preset.	5-81
:PRESet:SELEctch	Sets the channel to be preset or queries the current setting.	5-81
RECall Group		
:RECall:SETup<x>:EXECute	Recalls the setting parameters from the internal memory.	5-82
SEARCh Group		
:SEARCh?	Queries all settings related to the search & zoom function.	5-86
:SEARCh:ABORt	Aborts the search using the search & zoom function.	5-86
:SEARCh:ASCROll?	Queries all settings related to the auto scroll of the search & zoom function.	5-86
:SEARCh:ASCROll:DIRection	Sets the direction for moving the zoom box of the auto scroll when using the search & zoom function or queries the current setting.	5-86
:SEARCh:ASCROll:SPeEd	Sets the speed for moving the zoom box of the auto scroll when using the search & zoom function or queries the current setting.	5-86
:SEARCh:EDGE?	Queries all settings related to the edge search of the search & zoom function.	5-86
:SEARCh:EDGE:COUNt	Sets the edge detection count of the search & zoom function or queries the current setting.	5-86
:SEARCh:EDGE:HYSTeresis	Sets the hysteresis of the edge detection level of the search & zoom function or queries the current setting.	5-86
:SEARCh:EDGE:LEVEl	Sets the edge detection level of the search & zoom function or queries the current setting.	5-86
:SEARCh:EDGE:SLOPe	Sets the edge search slope of the search & zoom function or queries the current setting.	5-86
:SEARCh:EDGE:SOURce	Sets the target waveform of the edge search of the search & zoom function or queries the current setting.	5-87
:SEARCh:EXECute	Executes the search using the search & zoom function.	5-87
:SEARCh:MLINKage	Turns ON/OFF the link when changing the zoom rate of the search & zoom function or queries the current setting.	5-87

5.1 A List of Commands

Command	Function	Page
:SEARCH:MAG<x>	Sets the zoom rate of the zoom window of the search & zoom function or queries the current setting.	5-87
:SEARCH:PLINKage	Turns ON/OFF the link when moving the zoom box of the search & zoom function or queries the current setting.	5-87
:SEARCH:POSition<x>	Sets the zoom box position of the search & zoom function or queries the current setting.	5-87
:SEARCH:PPATtern?	Queries all settings related to the parallel pattern search of the search & zoom function.	5-87
:SEARCH:PPATtern:{CHANnel<x> MATH<x>}?	Queries all settings related to the waveform of the parallel pattern search of the search & zoom function.	5-87
:SEARCH:PPATtern:{CHANnel<x> MATH<x>}:HYSTeresis	Sets the hysteresis of the edge detection level of the target waveform of the parallel pattern search using the search & zoom function or queries the current setting.	5-87
:SEARCH:PPATtern:{CHANnel<x> MATH<x>}:LEVEl	Sets the criteria level of the target waveform of the parallel pattern search using the search & zoom function or queries the current setting.	5-88
:SEARCH:PPATtern:{CHANnel<x> MATH<x>}:PATtern	Sets the criteria status of the target waveform of the parallel pattern search using the search & zoom function or queries the current setting.	5-88
:SEARCH:PPATtern:CLOCK?	Queries all settings related to the clock channel of the parallel pattern search of the search & zoom function.	5-88
:SEARCH:PPATtern:CLOCK:HYSTeresis	Sets the search level hysteresis of the clock channel of the parallel pattern search using the search & zoom function or queries the current setting.	5-88
:SEARCH:PPATtern:CLOCK:LEVEl	Sets the search level of the clock channel of the parallel pattern search using the search & zoom function or queries the current setting.	5-88
:SEARCH:PPATtern:CLOCK:SLOPe	Sets the slope of the clock channel of the parallel pattern search using the search & zoom function or queries the current setting.	5-88
:SEARCH:PPATtern:CLOCK:SOURce	Sets the target waveform of the clock channel of the parallel pattern search using the search & zoom function or queries the current setting.	5-88
:SEARCH:SElect	Sets the detection waveform number of the search & zoom function and queries the zoom position corresponding to the detection waveform number.	5-89
:SEARCH:SElect? MAXimum	Queries the detection count of the search & zoom function.	5-89
:SEARCH:SPATtern?	Queries all settings related to the serial pattern search of the search & zoom function.	5-89
:SEARCH:SPATtern:CLEAr	Clears all search patterns of the serial pattern search using the search & zoom function (to Don't care).	5-89
:SEARCH:SPATtern:CLOCK?	Queries all settings related to the clock channel of the serial pattern search of the search & zoom function.	5-89
:SEARCH:SPATtern:CLOCK:HYSTeresis	Sets the hysteresis of the edge detection level of the clock channel of the serial pattern search using the search & zoom function or queries the current setting.	5-89
:SEARCH:SPATtern:CLOCK:LEVEl	SSets the search level of the clock channel of the serial pattern search using the search & zoom function or queries the current setting.	5-89
:SEARCH:SPATtern:CLOCK:SLOPe	Sets the slope of the clock channel of the serial pattern search using the search & zoom function or queries the current setting.	5-89
:SEARCH:SPATtern:CLOCK:SOURce	Sets the target waveform of the clock channel of the serial pattern search using the search & zoom function or queries the current setting.	5-89
:SEARCH:SPATtern:INTERval	Sets the search interval of search target waveform of the serial pattern search using the search & zoom function or queries the current setting.	5-90
:SEARCH:SPATtern:LEVEl	Sets the upper and lower limits of the status criteria level of the serial pattern search using the search & zoom function or queries the current setting.	5-90
:SEARCH:SPATtern:PATtern<x>	Sets the status criteria pattern of the serial pattern search using the search & zoom function or queries the current setting.	5-90
:SEARCH:SPATtern:PSElect	Sets the pattern number to which the status criteria pattern is assigned in the serial pattern search using the search & zoom function or queries the current setting.	5-90
:SEARCH:SPATtern:SOURce	Sets the search target waveform of the serial pattern search using the search & zoom function or queries the current setting.	5-90
:SEARCH:SPOint	Sets the search start point of the search & zoom function or queries the current setting.	5-90
:SEARCH:TWINdow	Sets the zoom window on which the searched section is displayed using the search & zoom function or queries the current setting.	5-90
:SEARCH:TYPE	Sets the search type of the search & zoom function or queries the current setting.	5-90

Command	Function	Page
:SEARCH:WIDTH?	Queries all settings related to the pulse width search of the search & zoom function.	5-90
:SEARCH:WIDTH:HYSteresis	Sets the hysteresis of the pulse width search level of the search & zoom function or queries the current setting.	5-91
:SEARCH:WIDTH:LEVel	Sets the pulse width search level of the search & zoom function or queries the current setting.	5-91
:SEARCH:WIDTH:POLarity	Sets the polarity of the pulse width search level of the search & zoom function or queries the current setting.	5-91
:SEARCH:WIDTH:SOURce	Sets the target waveform of the pulse width search of the search & zoom function or queries the current setting.	5-91
:SEARCH:WIDTH:TIME<x>	Sets the pulse width of the pulse width search of the search & zoom function or queries the current setting.	5-91
:SEARCH:WIDTH:TYPE	Sets the search type of the pulse width search of the search & zoom function or queries the current setting.	5-91
SNAP Group		
:SNAP	Executes snapshot.	5-92
SSTART Group		
:SSTART?	Starts the data acquisition with the trigger mode set to single.	5-92
START Group		
:START	Starts waveform acquisition.	5-92
STATUS Group		
:STATUS?	Queries all settings related to the communication status function.	5-93
:STATUS:CONDition?	Queries the status register.	5-93
:STATUS:EESe	Sets the extended event enable register or queries the current setting.	5-93
:STATUS:EESR?	Queries the extended event register and clears the register.	5-93
:STATUS:ERRor?	Queries the error code and the details of the error.	5-93
:STATUS:FILTer<x>	Sets the transition filter or queries the current setting.	5-94
:STATUS:QENable	Sets whether or not to store messages other than errors in the error queue or queries the current setting.	5-94
:STATUS:QMESsage	Sets whether or not to attach message information to the response to the ":STATUS:ERRor?" query or queries the current setting.	5-94
:STATUS:SPOLL?	Executes serial polling.	5-94
STOP Group		
:STOP	Stops the waveform acquisition.	5-94
STORE Group		
:STORE?	Queries information about the setting parameters that are stored to the internal memory.	5-95
:STORE:SETup<x>?	Queries information about the setting parameters that are stored to the internal memory at the specified number.	5-95
:STORE:SETup<x>:COMMeNt	Sets comments for the setting parameters that are to be stored to the internal memory at the specified number or queries the current setting.	5-95
:STORE:SETup<x>:DATE?	Queries the date and time for the setting parameters that are stored to the internal memory at the specified number.	5-95
:STORE:SETup<x>:EXECute	Saves the setting parameters to the internal memory at the specified number.	5-95
:STORE:SETup<x>:LOCK	Turns ON/OFF the protection for the setting parameters that are stored to the internal memory at the specified number or queries the current setting.	5-95
SYSTEM Group		
:SYSTEM?	Queries all settings related to the system.	5-97
:SYSTEM:BATTeRy?	Queries the lithium battery level.	5-97
:SYSTEM:CLICk	Turns the click sound ON/OFF or queries the current setting.	5-97
:SYSTEM:CLOCK?	Queries all settings related to date and time.	5-97
:SYSTEM:CLOCK:DATE	Sets the date or queries the current setting.	5-97
:SYSTEM:CLOCK:MODE	Turns the date and time display ON/OFF or queries the current setting.	5-97
:SYSTEM:CLOCK:SNTP	Queries the SNTP dettings.	5-97
:SYSTEM:CLOCK:SNTP:EXECute	Execute date and time setting per SNTP server.	5-97
:SYSTEM:CLOCK:SNTP:GMTTime	Sets/queries the difference from Greenwich mean time.	5-97
:SYSTEM:CLOCK:TIME	Sets the time or queries the current setting.	5-97
:SYSTEM:CLOCK:TYPE	Sets/queries the date and time setting method.	5-97
:SYSTEM:LANGUage	Sets the message language or queries the current setting.	5-97
:SYSTEM:LCD?	Queries all settings related to the LCD monitor.	5-97
:SYSTEM:LCD:AUTO?	Queries all settings related to the LCD backlight auto-off function.	5-97
:SYSTEM:LCD:AUTO:MODE	Turns the LCD backlight ON/OFF or queries the current setting.	5-97

5.1 A List of Commands

Command	Function	Page
:SYSTEM:LCD:AUTO:TIME	Sets the time for the LCD backlight auto-off function or queries the current setting.	5-98
:SYSTEM:LCD:BRIGhtness	Sets the brightness of the LCD monitor or queries the current setting.	5-98
:SYSTEM:LCD:MODE	Turns the LCD backlight ON/OFF or queries the current setting.	5-98
:SYSTEM:MLANGuage	Sets the menu language or queries the current setting.	5-98
:SYSTEM:OCANcel(Offset Cancel)	Sets whether or not to reflect the offset voltage to the measured results or the computed results or queries the current setting.	5-98
:SYSTEM:OVERview	Displays the system information.	5-98
:SYSTEM:SINformation	Display setting parameters.	5-98
:SYSTEM:TGATe	Sets the external trigger gate or queries the current setting.	5-98
:SYSTEM:USBKEYBoard	Sets the USB keyboard type or queries the current setting.	5-98
TIMEbase Group		
:TIMEbase?	Queries all settings related to the time base.	5-99
:TIMEbase:SOURce	Sets the time base or queries the current setting.	5-99
:TIMEbase:SRATe?	Queries the sample rate.	5-99
:TIMEbase:TDIV	Sets the T/div value or queries the current setting.	5-99
TRIGger Group		
:TRIGger?	Queries all settings related to the trigger.	5-104
:TRIGger:ABN?	Queries all settings related to the A -> B (n) trigger.	5-104
:TRIGger:ABN:COUNT	Sets the number of times condition B is to be met or queries the current setting.	5-104
:TRIGger:ACTion?	Queries all settings related to the action-on-trigger.	5-104
:TRIGger:ACTion:ACQCount	Sets the number of times to perform the action for the action-on-trigger or queries the current setting.	5-104
:TRIGger:ACTion:BUZZer	Sets whether or not to sound an alarm when the action is enabled or queries the current setting.	5-104
:TRIGger:ACTion:HCOPY	Sets whether or not to make a hard copy of the screen image data when the action is enabled or queries the current setting.	5-104
:TRIGger:ACTion:IMAGe	Sets whether or not to save the screen image to the external storage medium when action is activated or queries the current setting.	5-104
:TRIGger:ACTion:MAIL?	Queries all the setting values for mail reports sent as an ACTION.	5-104
:TRIGger:ACTion:MAIL:COUNT	Sets/queries the limit for the number of reports that are sent as an ACTION.	5-105
:TRIGger:ACTion:MAIL:MODE	Sets/queries whether mail reports are sent as an ACTION.	5-105
:TRIGger:ACTion:SAVE	Sets whether or not to save the waveform data when the action is enabled or queries the current setting.	5-105
:TRIGger:ACTion:START	Starts action-on-trigger.	5-105
:TRIGger:ACTion:STOP	Aborts action-on-trigger.	5-105
:TRIGger:ADB?	Queries all settings related to the A Delay B trigger.	5-105
:TRIGger:ADB:DELay	Sets the delay time of condition B or queries the current setting.	5-105
:TRIGger:ATRigger?	Queries all settings related to condition A.	5-105
:TRIGger:ATRigger:CHANnel<x>	Sets the condition of each channel for condition A or queries the current setting.	5-105
:TRIGger:ATRigger:CONDition	Sets the conditions for condition A or queries the current setting.	5-105
:TRIGger:BTRigger?	Queries all settings related to condition B.	5-105
:TRIGger:BTRigger:CHANnel<x>	Sets the condition of each channel for condition B or queries the current setting.	5-105
:TRIGger:BTRigger:CONDition	Sets the conditions for condition B or queries the current setting.	5-105
:TRIGger:DELay	Sets the delay or queries the current setting.	5-106
:TRIGger:HOLDoff?	Queries all settings related to the hold off.	5-106
:TRIGger:HOLDoff:TIME	Sets the hold off time or queries the current setting.	5-106
:TRIGger:MODE	Sets the trigger mode or queries the current setting.	5-106
:TRIGger:OR?	Queries all settings related to the OR trigger.	5-106
:TRIGger:OR:CHANnel<x>	Sets the edge of each channel or queries the current setting.	5-106
:TRIGger:OR:WINDow	Turns the window ON/OFF or queries the current setting.	5-106
:TRIGger:PATtern?	Queries all settings related to the pattern trigger.	5-106
:TRIGger:PATtern:CHANnel<x>	Sets the state of each channel or queries the current setting.	5-106
:TRIGger:PATtern:CLOCK?	Queries all settings related to the clock channel.	5-106
:TRIGger:PATtern:CLOCK:SLOPe	Sets the slope of the clock channel or queries the current setting.	5-106
:TRIGger:PATtern:CLOCK:SOURce	Sets the clock channel or queries the current setting.	5-106
:TRIGger:PATtern:CONDition	Sets the trigger condition or queries the current setting.	5-107
:TRIGger:POSition	Sets the trigger position or queries the current setting.	5-107
:TRIGger:SCount	Sets the number of times the trigger is activated when the trigger mode is set to Single (N) or queries the current setting.	5-107
:TRIGger[:SIMple]?	Queries all settings related to the simple trigger.	5-107
:TRIGger[:SIMple]:COUPLing	Sets the trigger coupling or queries the current setting.	5-107

Command	Function	Page
:TRIGger[:SIMple]:HFRejection	Turns the low-pass filter (HF rejection) ON/OFF or queries the current setting.	5-107
:TRIGger[:SIMple]:HYSTeresis	Sets the hysteresis on the search level or queries the current setting.	5-107
:TRIGger[:SIMple]:LEVel	Sets the trigger level of the specified channel or queries the current setting.	5-107
:TRIGger[:SIMple]:PROBE	Sets the probe when the trigger source is set to "EXTernal" or queries the current setting.	5-107
:TRIGger[:SIMple]:RANGe	Sets the external trigger input range and queries the current setting (DL1720E only).	5-107
:TRIGger[:SIMple]:SLOPE	Sets the trigger slope of the specified channel or queries the current setting.	5-108
:TRIGger[:SIMple]:SOURce	Sets the trigger source or queries the current setting.	5-108
:TRIGger:SOURce?	Queries all settings related to the trigger source for the enhanced trigger.	5-108
:TRIGger:SOURce:CHANnel<x>?	Queries all settings related to the trigger source of the specified channel.	5-108
:TRIGger:SOURce:CHANnel<x>:COUPling	Sets the trigger coupling of each channel or queries the current setting.	5-108
:TRIGger:SOURce:CHANnel<x>:HFRejection	Sets the HF rejection or queries the current setting.	5-108
:TRIGger:SOURce:CHANnel<x>:HYSTeresis	Sets the hysteresis on the search level or queries the current setting.	5-108
:TRIGger:SOURce:CHANnel<x>:LEVel	Sets the trigger level of each channel or queries the current setting.	5-108
:TRIGger:SOURce:CHANnel<x>:WIDTh	Sets the width of the window trigger or queries the current setting.	5-109
:TRIGger:TV?	Queries all settings related to the TV trigger.	5-109
:TRIGger:TV:FIELD	Sets the field or queries the current setting.	5-109
:TRIGger:TV:FRAME	Sets the frame skip function or queries the current setting.	5-109
:TRIGger:TV:LEVel	Sets the trigger level or queries the current setting.	5-109
:TRIGger:TV:LINE	Sets the line or queries the current setting.	5-109
:TRIGger:TV:POLarity	Sets the input polarity or queries the current setting.	5-109
:TRIGger:TV:TYPE	Sets the trigger input type or queries the current setting.	5-109
:TRIGger:TYPE	Sets the trigger type or queries the current setting.	5-109
:TRIGger:WIDTh?	Queries all settings related to the pulse width trigger.	5-109
:TRIGger:WIDTh:CHANnel<x>	Sets the trigger condition of each channel or queries the current setting.	5-109
:TRIGger:WIDTh:CONDition	Sets the trigger condition or queries the current setting.	5-110
:TRIGger:WIDTh:TIME<x>	Sets the pulse width or queries the current setting.	5-110
:TRIGger:WIDTh:TLINKage	Turns the link ON/OFF when changing the pulse width for the pulse width trigger or queries the current setting.	5-110
:TRIGger:WIDTh:TYPE	Sets the criteria type of the pulse width or queries the current setting.	5-110
:TRIGger:WIDTh:WINDow	Turns the window ON/OFF or queries the current setting.	5-110
WAVeform Group		
:WAVeform?	Queries all information related to the waveform data.	5-111
:WAVeform:BITS?	Queries the bit length of the specified waveform data.	5-111
:WAVeform:BYTeorder	Sets the transmission byte order or queries the current setting.	5-112
:WAVeform:DATaselect	Sets whether to use the ACQ data or P-P data when querying the waveform data or queries the current setting.	5-112
:WAVeform:END	Sets which point of the specified waveform is to be the last data point or queries the current setting.	5-112
:WAVeform:FORMat	Sets the transmission data format or queries the current setting.	5-112
:WAVeform:LENGth?	Queries the total data length of the specified waveform.	5-112
:WAVeform:OFFSet?	Queries the offset voltage of the specified waveform.	5-112
:WAVeform:RANGe?	Queries the range that is used when converting the waveform specified by the ":WAVeform:TRACe" command to physical values.	5-112
:WAVeform:RECOrd	Sets the target record number of the waveform group or queries the current setting.	5-112
:WAVeform:RECOrd? MINimum	Queries the smallest record number.	5-112
:WAVeform:SEND?	Queries the specified waveform data.	5-113
:WAVeform:SIGN?	Queries the existence of a sign.	5-113
:WAVeform:SRATe?	Queries the sample rate of the specified record.	5-113
:WAVeform:STARt	Sets which point of the specified waveform is to be the start data point or queries the current setting.	5-113
:WAVeform:TRACe	Sets the target waveform of the WAVeform group or queries the current setting.	5-113
:WAVeform:TRIGger?	Queries the trigger position of the specified record.	5-113
:WAVeform:TYPE?	Queries the acquisition mode of the specified waveform.	5-113
XY Group		
:XY<x>?	Queries all settings related to the X-Y display.	5-114
:XY<x>:DISPlay	Sets whether or not to display the X-Y waveform or queries the current setting.	5-114
:XY<x>:MODE	Sets the display mode or queries the current setting.	5-114
:XY<x>:TLINKage	Turns ON/OFF the linked movement of the determination range cursor.	5-114

5.1 A List of Commands

Command	Function	Page
:XY<x>:TRANge	Sets the range of the T-Y waveform to be used in the X-Y display or queries the current setting.	5-115
:XY<x>:XAXis	Sets the X-axis mode (Single/Dual) or queries the current setting.	5-115
:XY<x>:XTRace	Sets the channel that is to be assigned to the X-axis or queries the current setting.	5-115
:XY<x>:YTRace	Sets the channel that is to be assigned to the Y-axis or queries the current setting.	5-115
ZOOM Group		
:ZOOM?	Queries all settings related to the zooming of the waveform.	5-117
:ZOOM:ALLOcation?	Queries all settings related to the waveform being zoomed.	5-117
:ZOOM:ALLOcation:ALL	Selects all waveforms to be zoomed.	5-117
:ZOOM:ALLOcation:{CHANnel<x> MATH<x>}	Sets the waveform to be zoomed or queries the current setting.	5-117
:ZOOM:FITMeasure	Changes the range of the automated measurement of waveform parameters to the ends of the zoom box.	5-117
:ZOOM:FORMat	Sets the zoom waveform display format or queries the current setting.	5-117
:ZOOM:MLINKage	Turns the zoom rate link ON/OFF or queries the current setting.	5-117
:ZOOM:MAG<x>	Sets the zoom rate of the zoomed waveform or queries the current setting.	5-117
:ZOOM:MODE	Sets the zoom waveform display mode or queries the current setting.	5-117
:ZOOM:PLINKage	Turns the link ON/OFF when moving the zoom box or queries the current setting.	5-117
:ZOOM:POSition<x>	Sets the zoom box position or queries the current setting.	5-117
Common Command Group		
*CAL?	Executes calibration and queries the result.	5-118
*CLS	Clears the standard event register, extended event register, and error queue.	5-118
*ESE	Sets the standard event enable register or queries the current setting.	5-118
*ESR?	Queries the standard event register and clears the register.	5-119
*IDN?	Queries the instrument model.	5-119
*LRN?	Queries all current settings of the command group.	5-119
*OPC	Sets the OPC event after the completion of the specified overlap command.	5-119
*OPC?	Creates a response upon the completion of the specified overlap command.	5-120
*OPT?	Queries the installed options.	5-120
*PSC	Sets whether or not to clear the registers at power up or queries the current setting.	5-120
*RST	Initializes the command group's settings.	5-120
*SRE	Sets the service request enable register or queries the current setting.	5-120
*STB?	Queries the status byte register.	5-120
*TST?	Executes self test and queries the result.	5-120
*WAI	Holds the subsequent command until the completion of the specified overlap operation.	5-120

5.2 ACQuire Group

The commands in the ACQuire group are used for making settings and queries about acquisition. This allows you to make the same settings that you can make using ACQ on the front panel.

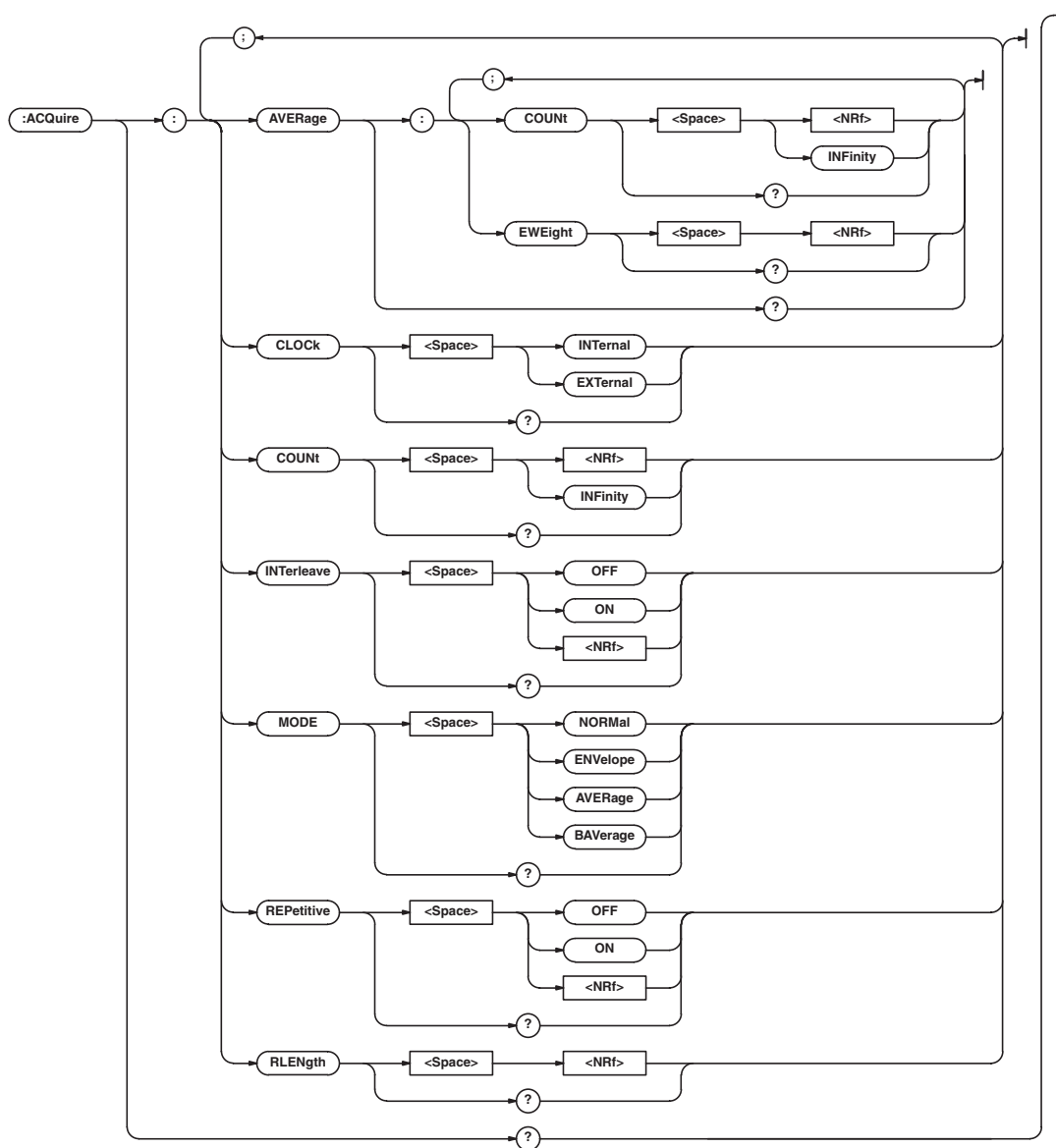

5.2 ACQUIRE Group

:ACQUIRE?

Function Queries all the acquisition settings.
Syntax :ACQUIRE?
Example :ACQUIRE? -> :ACQUIRE:RLENGTH 1000;
MODE NORMAL;AVERAGE:COUNT INFINITY;
EWEIGHT 16;ACQUIRE:COUNT INFINITY;
INTERLEAVE 0;REPETITIVE 0;
CLOCK INTERNAL

:ACQUIRE:AVERAGE?

Function Queries all the averaging and acquisition count settings.
Syntax :ACQUIRE:AVERAGE?
Example :ACQUIRE:AVERAGE? -> :ACQUIRE:
AVERAGE:COUNT INFINITY;EWEIGHT 16

:ACQUIRE:AVERAGE:COUNT

Function Sets/queries the acquisition count in averaging mode.
Syntax :ACQUIRE:AVERAGE:COUNT
{<NRf>|INFINITY}
:ACQUIRE:AVERAGE:COUNT?
<NRf>=2 to 65536 (in steps of 2ⁿ)
Example :ACQUIRE:AVERAGE:COUNT INFINITY
:ACQUIRE:AVERAGE:COUNT? ->
:ACQUIRE:AVERAGE:COUNT INFINITY

:ACQUIRE:AVERAGE:EWEIGHT (Exponent WEIGHT)

Function Sets/queries the average weight for infinite averaging mode.
Syntax :ACQUIRE:AVERAGE:EWEIGHT {<NRf>}
:ACQUIRE:AVERAGE:EWEIGHT?
<NRf>=2 to 256 (in steps of 2ⁿ)
Example :ACQUIRE:AVERAGE:EWEIGHT 16
:ACQUIRE:AVERAGE:EWEIGHT? ->
:ACQUIRE:AVERAGE:EWEIGHT 16

:ACQUIRE:CLOCK

Function Sets/queries the time base.
Syntax :ACQUIRE:{INTERNAL|EXTERNAL}
:ACQUIRE:CLOCK?
Example :ACQUIRE:CLOCK INTERNAL
:ACQUIRE:CLOCK? ->
:ACQUIRE:CLOCK INTERNAL

:ACQUIRE:COUNT

Function Sets the number of waveform acquisitions during normal mode, envelope mode, and box average or queries the current setting.
Syntax :ACQUIRE:COUNT {<NRf>|INFINITY}
:ACQUIRE:COUNT?
<NRf>=2 to 65536
Example :ACQUIRE:COUNT INFINITY
:ACQUIRE:COUNT? ->
:ACQUIRE:COUNT INFINITY

:ACQUIRE:INTERLEAVE

Function Turns the interleave mode ON/OFF or queries the current setting.
Syntax :ACQUIRE:INTERLEAVE {<Boolean>}
:ACQUIRE:INTERLEAVE?
Example :ACQUIRE:INTERLEAVE ON
:ACQUIRE:INTERLEAVE? ->
:ACQUIRE:INTERLEAVE 1

:ACQUIRE:MODE

Function Sets/queries the acquisition mode.
Syntax :ACQUIRE:MODE{AVERAGE|BAVERAGE|
ENVELOPE|NORMAL}
:ACQUIRE:MODE?
Example :ACQUIRE:MODE NORMAL
:ACQUIRE:MODE? ->
:ACQUIRE:MODE NORMAL

:ACQUIRE:REPETITIVE

Function Turns the repetitive sampling mode ON/OFF or queries the current setting.
Syntax :ACQUIRE:REPETITIVE {<Boolean>}
:ACQUIRE:REPETITIVE?
Example :ACQUIRE:REPETITIVE OFF
:ACQUIRE:REPETITIVE? ->
:ACQUIRE:REPETITIVE 0

:ACQUIRE:RLENGTH

Function Sets/queries the record length.
Syntax :ACQUIRE:RLENGTH {<NRf>}
:ACQUIRE:RLENGTH?
<NRf>= 1000 to 1000000 (DL1720E)
1000 to 2000000 (DL1740E)
1000 to 8000000 (DL1740EL)
Example :ACQUIRE:RLENGTH 1000
:ACQUIRE:RLENGTH? ->
:ACQUIRE:RLENGTH 1000

5.3 ASETup Group

The commands in the ASETup group are used for setting and querying auto-setup. This allows you to make the same settings and queries that you can make using the Auto Setup menu of SETUP on the front panel.

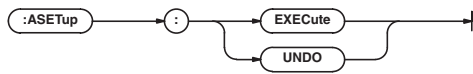

:ASETup:EXECute

Function Executes auto-setup.
 Syntax :ASETup:EXECute
 Example :ASETUP:EXECUTE

:ASETup:UNDO

Function Cancels auto set-up settings.
 Syntax :ASETup:UNDO
 Example :ASETUP:UNDO

5.4 CALibrate Group

The commands in the CALibrate group are used for setting and querying the calibration. This allows you to make the same settings that you can make using the Calibration menu of MISC on the front panel.

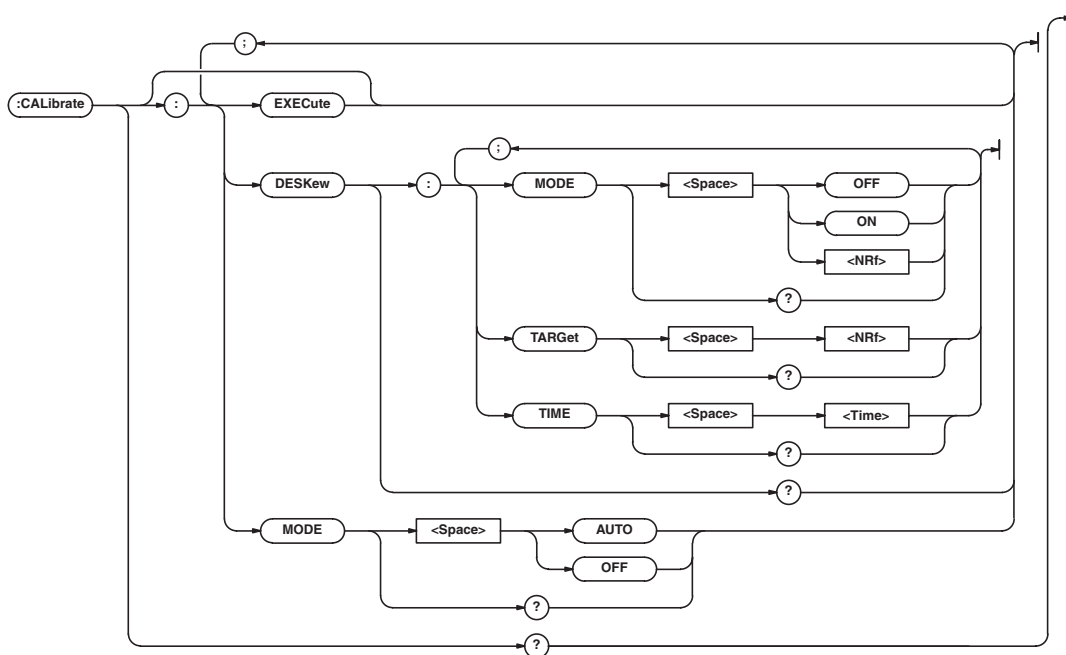

:CALibrate?

Function Queries all calibration settings.
 Syntax :CALibrate?
 Example :CALIBRATE? -> :CALIBRATE:MODE OFF;
 DESKEW:MODE 0;TARGET 1;TIME 0.0E+00

:CALibrate:DESKew?

Function Queries all settings related to skew compensation.
 Syntax :CALibrate:DESKew?
 Example :CALIBRATE:DESKEW? ->
 :CALIBRATE:DESKEW:MODE 0;TARGET 1;
 TIME 0.0E+00

:CALibrate:DESKew:MODE

Function Turns the skew compensation ON/OFF or queries the current setting.
 Syntax :CALibrate:DESKew:MODE {<Boolean>}
 :CALibrate:DESKew:MODE?
 Example :CALIBRATE:DESKEW:MODE ON
 :CALIBRATE:DESKEW:MODE? ->
 :CALIBRATE:DESKEW:MODE 0

:CALibrate:DESKew:TARGet

Function Sets the channel on which skew compensation is to be performed or queries the current setting.
 Syntax CALibrate:DESKew:TARGet {<NRf>}
 :CALibrate:DESKew:TARGet?
 <NRf>=1 to 4 (1 to 2 on the DL1720E)
 Example :CALIBRATE:DESKEW:TARGET 1
 :CALIBRATE:DESKEW:TARGET? ->
 :CALIBRATE:DESKEW:TRAGET 1

:CALibrate:DESKew:TIME

Function Sets the skew compensation time that are common to all channels or queries the current setting.
 Syntax :CALibrate:DESKew:TIME {<time>}
 :CALibrate:DESKew:TIME?
 <time>=-100 ns to 100 ns
 Example :CALIBRATE:DESKEW:TIME 1NS
 :CALIBRATE:DESKEW:TIME? ->
 :CALIBRATE:DESKEW:TIME 1.000E-09

5.4 CALibrate Group

:CALibrate[:EXECute]

Function Executes calibration.

Syntax :CALibrate[:EXECute]

Example :CALIBRATE:EXECUTE

:CALibrate:MODE

Function Sets/queries the ON/OFF of the auto calibration.

Syntax :CALibrate:MODE {AUTO|OFF}

:CALibrate?

Example :CALIBRATE:MODE AUTO

:CALIBRATE? -> :CALIBRATE:MODE AUTO

5.5 CHANnel Group

The commands in the CHANnel group are used to make settings and queries about the vertical axis of the specified channel. This allows you to make the same settings that you can make using VERTICAL (CH, V/DIV).

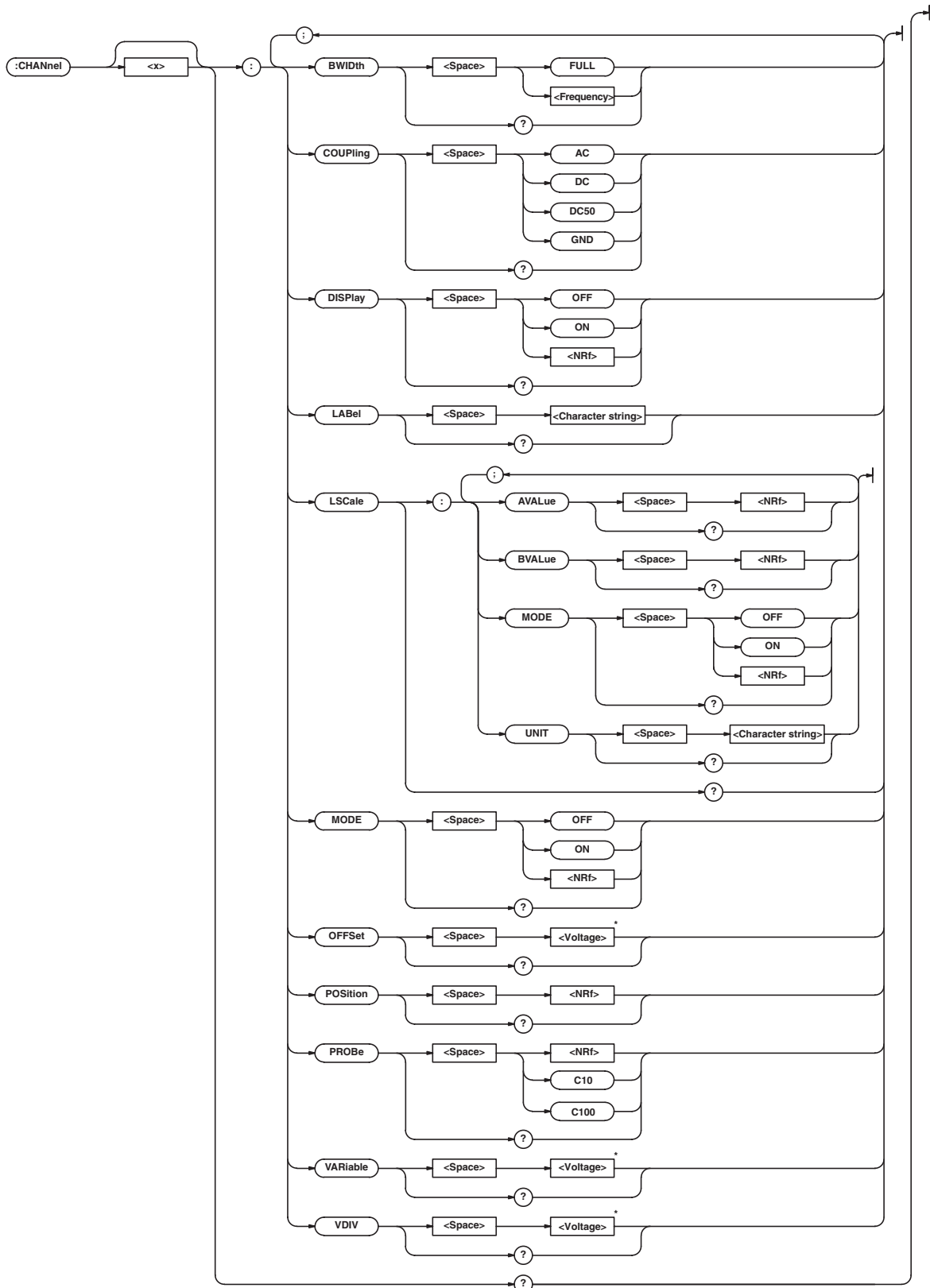

* When the target channel is set to the current probe, becomes <Current>.

5.5 CHANnel Group

:CHANnel<x>?

Function Queries all settings related to the vertical axis of the channel.

Syntax :CHANnel<x>?

Example :CHANNEL? -> :CHANNEL1:DISPLAY 1;
VDIV 50.000E+00;POSITION 0.00;
COUPLING DC;PROBE 10;
OFFSET 0.0E+00;BWIDTh FULL;
VARIABLE 50.000E+00;LSCALE:MODE 0;
AVALUE 1.00000E+00;
BVALUE 0.00000E+00;UNIT "V";;
CHANNEL1:LABEL "CH1"

:CHANnel<x>:BWIDTh

Function Sets the input filter of the channel or queries the current setting.

Syntax :CHANnel<x>:BWIDTh
{FULL|<Frequency>}
:CHANnel<x>:BWIDTh?
<x>=1 to 4 (1 to 2 on the DL1720E)
{<Frequency>}=20 MHz or 100 MHz

Example :CHANNEL1:BWIDTh FULL
:CHANNEL1:BWIDTh? ->
:CHANNEL1:BWIDTh FULL

:CHANnel<x>:COUPLing

Function Sets the input coupling of the channel or queries the current setting.

Syntax :CHANnel<x>:COUPLing
{AC|DC|DC50|GND}
:CHANnel<x>:COUPLing?
<x>=1 to 4 (1 to 2 on the DL1720E)

Example :CHANNEL1:COUPLing DC
:CHANNEL1:COUPLing? ->
:CHANNEL1:COUPLing DC

:CHANnel<x>:DISPlay

Function Turns ON/OFF the channel or queries the current setting.

Syntax :CHANnel<x>:DISPlay {<Boolean>}
:CHANnel<x>:DISPlay?
<x>=1 to 4 (1 to 2 on the DL1720E)

Example :CHANNEL1:DISPlay ON
:CHANNEL1:DISPlay? ->
:CHANNEL1:DISPlay 1

Description The ":CHANnel<x>:MODE" command can be used to make the same settings and inquiries.

:CHANnel<x>:LABel

Function Sets the waveform label of channel or queries the current setting.

Syntax :CHANnel<x>:LABel {<Character string>}
:CHANnel<x>:LABel?
<x>=1 to 4 (1 to 2 on the DL1720E)
<Character string>=Up to 8 characters

Example :CHANNEL1:LABel "CH1"
:CHANNEL1:LABel? ->
:CHANNEL1LABel "CH1"

Description Only the characters and symbols displayed on the keyboard on the screen can be used. In ASCII code Ω and μ are expressed as 1EH and 1FH, respectively.

:CHANnel<x>:LSCale?

Function Queries all settings related to the linear scaling of the channel.

Syntax :CHANnel<x>:LSCale
<x>=1 to 4 (1 to 2 on the DL1720E)

Example :CHANNEL1:LSCALE? -> :CHANNEL1:
LSCALE:MODE 1;AVALUE 1.00000E+00;
BVALUE 0.00000E+00;UNIT "V"

:CHANnel<x>:LSCale:AVALue

Function Sets scaling coefficient A or queries the current setting.

Syntax :CHANnel<x>:LSCale:AVALue {<NRf>}
:CHANnel<x>:LSCale:AVALue?
<x>=1 to 4 (1 to 2 on the DL1720E)
<NRf>=-9.9999E+30 to 9.9999E+30

Example :CHANNEL1:LSCALE:AVALUE 10
:CHANNEL1:LSCALE:AVALUE? ->
:CHANNEL1:LSCALE:AVALUE 10.0000E+00

:CHANnel<x>:LSCale:BVALue

Function Sets offset value B or queries the current setting.

Syntax :CHANnel<x>:LSCale:BVALue {<NRf>}
:CHANnel<x>:LSCale:BVALue?
<x>=1 to 4 (1 to 2 on the DL1720E)
<NRf>=-9.9999E+30 to 9.9999E+30

Example :CHANNEL1:LSCALE:BVALUE 10
:CHANNEL1:LSCALE:BVALUE? ->
:CHANNEL1:LSCALE:BVALUE 10.0000E+00

:CHANnel<x>:LSCale:MODE

Function Turns ON/OFF the linear scaling or queries the current setting.

Syntax :CHANnel<x>:LSCale:MODE {<Boolean>}
:CHANnel<x>:LSCale:MODE?
<x>=1 to 4 (1 to 2 on the DL1720E)

Example :CHANNEL1:LSCALE:MODE ON
:CHANNEL1:LSCALE:MODE? ->
:CHANNEL1:LSCALE:MODE 1

:CHANnel<x>:LSCale:UNIT

Function Sets the unit of the value after it is scale or queries the current setting.

Syntax :CHANnel<x>:LSCale:UNIT {<Character string>}
:CHANnel<x>:LSCale:UNIT?
<x>=1 to 4 (1 to 2 on the DL1720E)
<Character string>=Up to 4 characters

Example :CHANNEL1:LSCALE:UNIT "EU"
:CHANNEL1:LSCALE:UNIT? ->
:CHANNEL1:LSCALE:UNIT "EU"

Description Only the characters and symbols displayed on the keyboard on the screen can be used. In ASCII code Ω and μ are expressed as 1EH and 1FH, respectively. The unit does not affect the scaled value in any way.

:CHANnel<x>:MODE

Function Turns ON/OFF the display of the channel or queries the current setting.

Syntax :CHANnel<x>:MODE {<Boolean>}
:CHANnel<x>:MODE?

Example <x>=1 to 4 (1 to 2 on the DL1720E)
:CHANNEL1:MODE ON
:CHANNEL1:MODE? -> :CHANNEL1:MODE 1

Description The "CHANnel<x>:DISPlay" command can be used to make the same settings and inquiries.

:CHANnel<x>:OFFSet

Function Sets the offset voltage of the channel or queries the current setting.

Syntax :CHANnel<x>:OFFSet {<Voltage>}
:CHANnel<x>:OFFSet?

Example <x>=1 to 4 (1 to 2 on the DL1720E)
<Voltage>=See the User's Manual
:CHANNEL1:OFFSET 0V
:CHANNEL1:OFFSET? ->
:CHANNEL1:OFFSET 0.000E+00

Description When a current probe is used, this command sets or queries the <Current> value.

:CHANnel<x>:POSition

Function Sets the vertical position of the channel or queries the current setting.

Syntax :CHANnel<x>:POSition {<Nrf>}
:CHANnel<x>:POSition?

Example <x>=1 to 4 (1 to 2 on the DL1720E)
<Nrf>=-4 to 4div (1/100 steps)
:CHANNEL1:POSITION 1
:CHANNEL1:POSITION? ->
:CHANNEL1:POSITION 1.00E+00

:CHANnel<x>:PROBe

Function Sets the probe attenuation/current-to-voltage conversion ratio of the channel or queries the current setting.

Syntax :CHANnel<x>:PROBe {<Nrf>|C10|C100}
:CHANnel<x>:PROBe?

Example <x>=1 to 4 (1 to 2 on the DL1720E)
<Nrf>=1, 10, 100, or 1000 (see the User's Manual)
:CHANNEL1:PROBE
:CHANNEL1:PROBE? ->
:CHANNEL1:PROBE 1

Description When using the current probe, specify "C10" (10 A:1 V) or "C100" (100 A:1 V), respectively.

:CHANnel<x>:VARIable

Function Sets the voltage sensitivity of the channel in 0.01 steps of the V/div setting or queries the current setting.

Syntax :CHANnel<x>:VARIable {<Voltage>}
:CHANnel<x>:VARIable?

Example <x>=1 to 4 (1 to 2 on the DL1720E)
<Voltage>=See the Use's Manual
:CHANNEL1:VARIABLE 1V
:CHANNEL1:VARIABLE? ->
:CHANNEL1:VARIABLE 1.000E+00

Description When a current probe is used, this command sets or queries the <Current> value.

:CHANnel<x>:VDIV

Function Sets the voltage sensitivity (V/div) of the channel or queries the current setting.

Syntax :CHANnel<x>:VDIV {<Voltage>}
:CHANnel<x>:VDIV?

Example <x>=1 to 4 (1 to 2 on the DL1720E)
<Voltage>=2 mV to 10V (when the probe attenuation is 1:1, see the User's Manual)
:CHANNEL1:VDIV 2V
:CHANNEL1:VDIV? ->
:CHANNEL1:VDIV 2.000E+00

Description When a current probe is used, this command sets or queries the <Current> value.

5.6 CLEAr Group

5.6 CLEAr Group

The CLEAr command is used to clear the trace. This allows you to perform the same operation that you can perform using CLEAR TRACE on the front panel.

 :CLEAr

:CLEAr

Function	Clears trace.
Syntax	:CLEAr
Example	:CLEAR

5.7 COMMunicate Group

The commands in the COMMunicate group are used to make settings and queries about communications. There is no front panel key with this function.

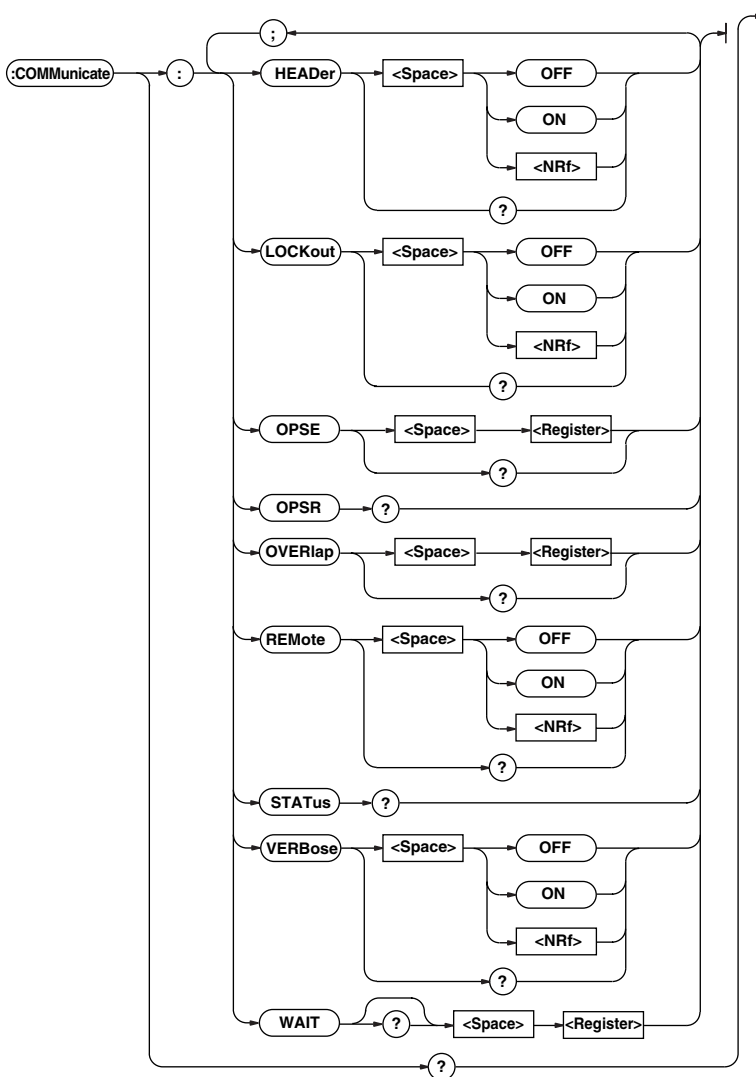

:COMMunicate?

Function Queries all communication settings.
 Syntax :COMMunicate?
 Example :COMMUNICATE? -> :COMMUNICATE:
 HEADER 1;OPSE 352;OVERLAP 352;
 VERBOSE 1

:COMMunicate:HEADer

Function Determines whether a header is to be added (for example: CHANNEL1:VOLTAGE:PROBE 10) or nt (example: 10) when sending a response to a query; or queries the current setting.
 Syntax :COMMunicate:HEADer {<Boolean>}
 :COMMunicate:HEADer?
 Example :COMMUNICATE:HEADER ON
 :COMMUNICATE:HEADER? ->
 :COMMUNICATE:HEADER 1

:COMMunicate:LOCKout

Function Sets/releases the local lockout.
 Syntax :COMMunicate:LOCKout {<Boolean>}
 Example :COMMUNICATE:LOCKOUT ON
 :COMMUNICATE:LOCKOUT? ->
 :COMMUNICATE:LOCKOUT 1
 Description This is an exclusive command for the USB interface or Ethernet interface (option).

5.7 COMMunicate Group

:COMMunicate:OPSE

(Operation Pending Status Enable register)
Function Sets the overlap command to be used with *OPC, *OPC?, and *WAI, or queries the current setting.
Syntax :COMMunicate:OPSE <Register>
:COMMunicate:OPSE?
<Register>=0 to 65535, refer to the figure on the next page.
Example :COMMUNICATE:OPSE 65535
:COMMUNICATE:OPSE? ->
:COMMUNICATE:OPSE 352
Description In the above example, all bits are masked to "1" so that all overlap commands can be used by this command. However, bits that are fixed as "0" cannot be set to "1, so only bits 5, 6 and 8 are actually set to "1" and appears as "1" when a query is made.

:COMMunicate:OPSR?

(Operation Pending Status Register)

Function Inquires about the value in the operation pending status register.
Syntax :COMMunicate:OPSR?
Example :COMMUNICATE:OPSR? -> 0
Description For a description of the operation pending status register, refer to the figure on the next page.

:COMMunicate:OVERlap

Function Selects/queries the commands enabled for overlap.
Syntax :COMMunicate:OVERlap <Register>
:COMMunicate:OVERlap?
<Register>=0 to 65535, refer to the figure on the next page.
Example :COMMUNICATE:OVERLAP 65535
:COMMUNICATE:OVERLAP? ->
:COMMUNICATE:OVERLAP 352
Description

- In the above example, all bits are set to "1" so that all overlap commands can be used by this command. However, bits that are fixed as "0" cannot be set to "1," so only bits 5, 6 and 8 are actually set to "1" and appears as "1" when a query is made.
- COMMunicate: For the synchronization method using "OVERlap," refer to page 4-8.
- In the above example, bits 5, 6 and 8 are set to "1" so that all overlap commands can be used by this command. (Refer to the figure on the next pag.)

:COMMunicate:REMOte

Function Sets remote/local. It is in remote mode when it is set to ON.
Syntax :COMMunicate:REMOte {<Boolean>}
:COMMunicate:REMOte?
Example :COMMUNICATE:REMOTE ON
:COMMUNICATE:REMOTE? ->
:COMMUNICATE:REMOTE 1
Description This is an exclusive command for the USB interface, or Ethernet interface option).

:COMMunicate:STAus?

Function Queries the circuit status.
Syntax :COMMunicate:STAus?
Example :COMMUNICATE:STATUS? ->
:COMMUNICATE:STATUS 0
Description Status-bit meanings are as follows.

Bit	GP-IB
0	Unrecoverable transmission error
1	Always 0
2	Always 0
3 to	Always 0
USB/Ethernet interface: Always 0	

Description Status bit sets when cause occurs, and clears when read.

:COMMunicate:VERBOse

Function Determines whether a response to a query is to be returned in full form (for example: CHANNEL1:VOLTAGE:PROBE 10) or in abbreviated form (for example: CHAN:PROB 10), or queries the current setting.
Syntax :COMMunicate:VERBOse {<Boolean>}
:COMMunicate:VERBOse?
Example :COMMUNICATE:VERBOSE ON
:COMMUNICATE:VERBOSE? ->
:COMMUNICATE:VERBOSE 1

:COMMunicate:WAIT

Function Waits until one of the specified extended events occurs.
Syntax :COMMunicate:WAIT <Register>
<Register>=0 to 65535 (Extended event register; refer to page 6-4.)
Example :COMMUNICATE:WAIT 65535
Description COMMunicate: For a description of the synchronizing method using "WAIT," refer to page 4-8.

:COMMunicate:WAIT?

Function Generates a response when one of the specified extended events occurs.
Syntax :COMMunicate:WAIT? <Register>
<Register>=0 to 65535 (Extended event register; refer to page 6-4.)
Example :COMMUNICATE:WAIT? 65535 -> 1

Operation pending status register/overlap enable register

15	14	13	12	11	10	9	8	7	6	5	4	3	2	1	0
0	0	0	0	SCH	0	0	HST	0	ACS	PRN	0	0	0	0	0

When bit 5 (PRN)=1:
Printer operation not completed
When bit 6 (ACS)=1:
Medium not accessed
When bit 8 (HST)=1:
History search not completed
When bit 11 (SCH)=1:
Edge/pattern search not completed

5.8 CURSOR Group

The commands in the CURSOR group are used to make cursor measurement settings and queries. This allows you to make the same settings that you can make using CURSOR on the front panel.

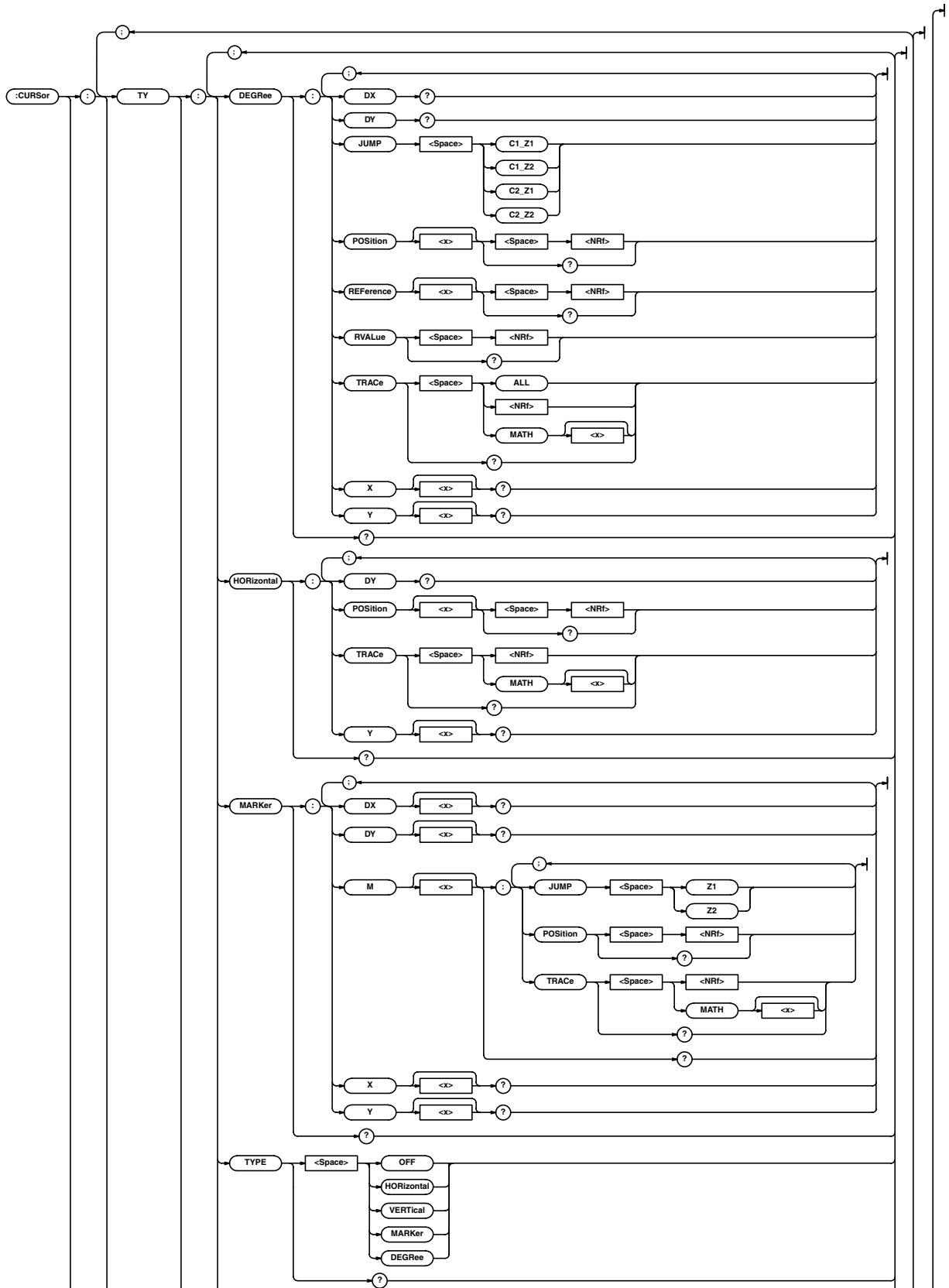

5.8 CURSor Group

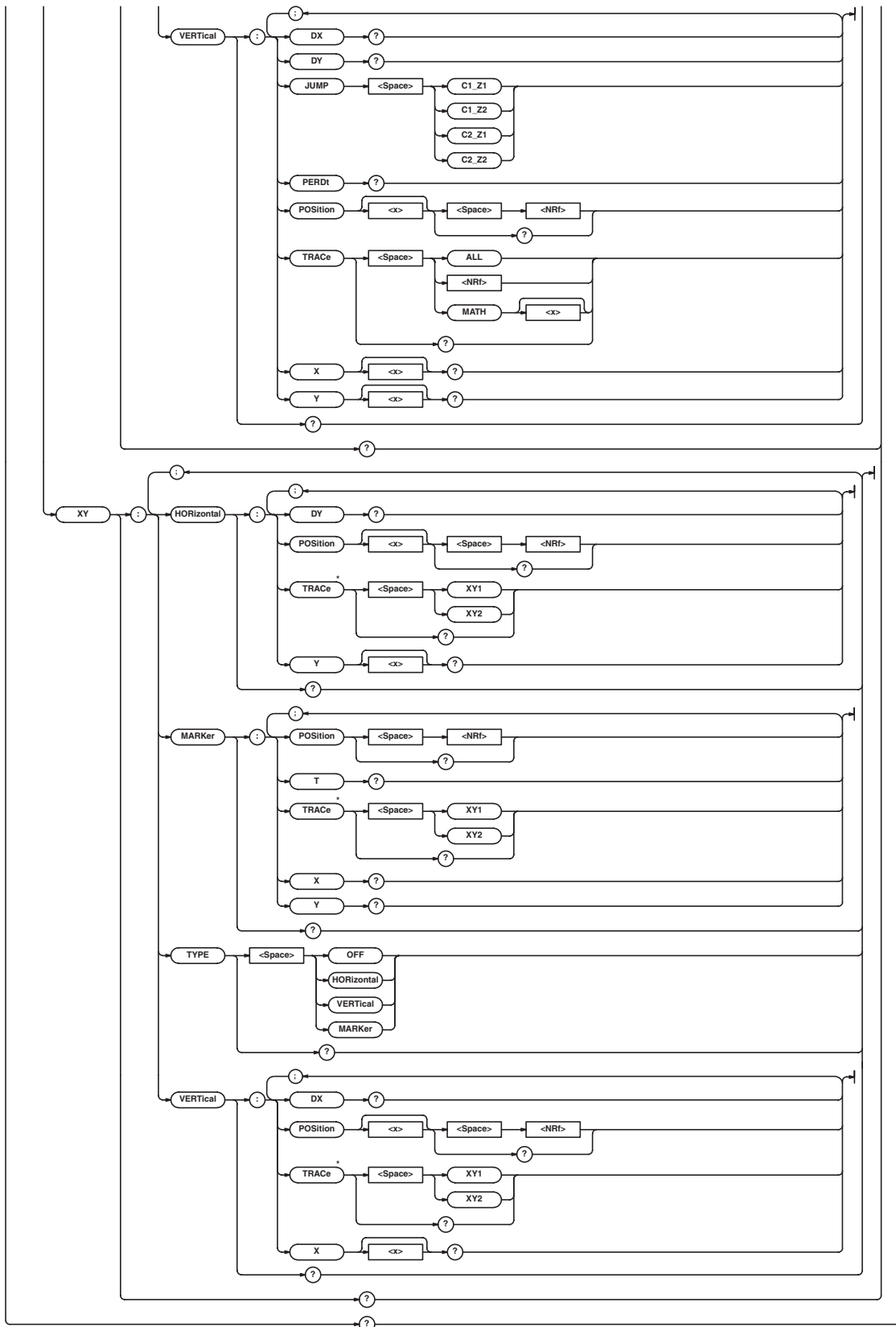

* For use on the DL1740E/DL1740EL.

:CURSOR?

Function Queries all settings related to cursor measurements.

Syntax :CURSOR?

Example :CURSOR? -> :CURSOR:TY:TYPE OFF;
HORIZONTAL:TRACE 1;POSITION1 3.00;
POSITION2 3.00;:CURSOR:TY:VERTICAL:
TRACE 1;POSITION1 -4.0000000;
POSITION2 4.0000000;:CURSOR:TY:
MARKER:M1:TRACE 1;
POSITION -3.0000000;:CURSOR:TY:
MARKER:M2:TRACE 2;
POSITION -1.0000000;:CURSOR:TY:
MARKER:M3:TRACE 3;
POSITION 1.0000000;:CURSOR:TY:
MARKER:M4:TRACE 4;
POSITION 3.0000000;CURSOR:TY:
DEGREE:TRACE 1;
POSITION1 -4.0000000;
POSITION2 4.0000000;
REFERENCE1 -2.0000000;
REFERENCE2 2.0000000;RVALUE 90;:
CURSOR:XY:TYPE OFF;HORIZONTAL:
TRACE XY1;POSITION1 3.00;
POSITION2 -3.00;:CURSOR:XY:
VERTICAL:TRACE XY1;POSITION1 -3.00;
POSITION2 3.00;:CURSOR:XY:MARKER:
TRACE XY1;POSITION -3.0000000

:CURSOR:TY?

Function Queries all settings related to the cursor in the T-Y display.

Syntax :CURSOR:TY?

Example :CURSOR:TY? -> :CURSOR:TY:TYPE OFF;
HORIZONTAL:TRACE 1;POSITION1 3.00;
POSITION2 -3.00;:CURSOR:TY:
VERTICAL:TRACE 1;
POSITION1 -4.0000000;
POSITION2 4.0000000;:CURSOR:TY:
MARKER:M1:TRACE 1;
POSITION -3.0000000;:CURSOR:TY:
MARKER:M2:TRACE 2;
POSITION -1.0000000;:CURSOR:TY:
MARKER:M3:TRACE 3;
POSITION 1.0000000;:CURSOR:TY:
MARKER:M4:TRACE 4;
POSITION 3.0000000;:CURSOR:TY:
DEGREE:TRACE 1;
POSITION1 -4.0000000;
POSITION2 4.0000000;
REFERENCE1 -2.0000000;
REFERENCE2 2.0000000;RVALUE 90

:CURSOR:TY:DEGREE?

Function Queries all settings related to angle cursors in the T-Y display.

Syntax :CURSOR:TY:DEGREE?

Example :CURSOR:TY:DEGREE? -> :CURSOR:TY:
DEGREE:TRACE 1;
POSITION1 -4.0000000;
POSITION2 4.0000000;
REFERENCE1 -2.0000000;
REFERENCE2 2.0000000;RVALUE 90

:CURSOR:TY:DEGREE:DX?

Function Queries the angle difference, ΔD , between angle cursors in the T-Y display.

Syntax :CURSOR:TY:DEGREE:DX?

Example :CURSOR:TY:DEGREE:DX? ->
:CURSOR:TY:DEGREE:DX 180.000000E+00

:CURSOR:TY:DEGREE:DY?

Function Queries the angle difference, ΔV , between angle cursors in the T-Y display.

Syntax :CURSOR:TY:DEGREE:DY?

Example :CURSOR:TY:DEGREE:DY? ->
:CURSOR:TY:DEGREE:DY 5.2500000E-03

:CURSOR:TY:DEGREE:JUMP

Function Moves the angle cursor in the T-Y display to the specified zoomed waveform.

Syntax :CURSOR:TY:DEGREE:JUMP {C1_Z1|
C1_Z2|C2_Z1|C2_Z2}

Example :CURSOR:TY:DEGREE:JUMP C1_Z1

Description The cursor jumps to the center position of the zoomed waveform. C1 and C2 represent Cursor1 and Cursor2, respectively.

:CURSOR:TY:DEGREE:POSITION<x>

Function Sets the position of the angle cursor in the T-Y display or queries the current setting.

Syntax :CURSOR:TY:DEGREE:POSITION<x>
{<NRf>}
:CURSOR:TY:DEGREE:POSITION<x>?
<x>=1 or 2
<NRf>=-5 to 5 (10 div/displayed record length steps)

Example :CURSOR:TY:DEGREE:POSITION1 2
:CURSOR:TY:DEGREE:POSITION1? ->
:CURSOR:TY:DEGREE:
POSITION1 2.0000000

:CURSOR:TY:DEGREE:REFERENCE<x>

Function Sets the position of the zero point (Reference 1) or the end point (Reference 2) that will be used as a reference in the angle cursor measurement or queries the current setting.

Syntax :CURSOR:TY:DEGREE:REFERENCE<x>
{<NRf>}
:CURSOR:TY:DEGREE:REFERENCE<x>?
<x>=1 or 2
<NRf>=-5 to 5 (10 div/displayed record length steps)

Example :CURSOR:TY:DEGREE:REFERENCE1 -1
:CURSOR:TY:DEGREE:REFERENCE1? ->
:CURSOR:TY:DEGREE:
REFERENCE1 -1.0000000

:CURSOR:TY:DEGREE:RVALUE

Function Sets the reference angle of the angle cursor or queries the current setting.

Syntax :CURSOR:TY:DEGREE:RVALUE {<NRf>}
:CURSOR:TY:DEGREE:RVALUE?
<NRf>=1 to 720

Example :CURSOR:TY:DEGREE:RVALUE 180
:CURSOR:TY:DEGREE:RVALUE? ->
:CURSOR:TY:DEGREE:RVALUE 180

5.8 CURSor Group

:CURSor:TY:DEGREE:TACe

Function Sets the waveform on which to use the angle cursor in the T-Y display or queries the current setting.

Syntax :CURSor:TY:DEGREE:TRACe {<NRf> | MATH<x> | PODA | POdB | PODA_POdB | ALL} :CURSor:TY:DEGREE:TRACe? <NRf>=1 to 4 (1 to 2 on the DL1720E) <x>=1 or 2 (1 on the DL1720E)

Example :CURSOR:TY:DEGREE:TRACE 1 :CURSOR:TY:DEGREE:TRACE? -> :CURSOR:TY:DEGREE:TRACE 1

Description An error occurs if PODA, POdB, or PODA_POdB is specified when the logic input (option) is not installed.

:CURSor:TY:DEGREE:X<x>?

Function Queries the angle at the angle cursor in the T-Y display.

Syntax :CURSor:TY:DEGREE:X<x>? <x>=1 or 2

Example (This is an example in which Cursor1 is queried.) :CURSOR:TY:DEGREE:X1? -> :CURSOR:TY:DEGREE:X1 -120.00000E+00

:CURSor:TY:DEGREE:Y<x>?

Function Queries the voltage value at the angle cursor in the T-Y display.

Syntax :CURSor:TY:DEGREE:Y<x>? <x>=1 or 2

Example (This is an example in which Cursor1 is queried.) :CURSOR:TY:DEGREE:Y1? -> :CURSOR:TY:DEGREE:Y1 10.000000E-03

:CURSor:TY:HORizontal?

Function Queries all settings related to horizontal cursors in the T-Y display.

Syntax :CURSor:TY:HORizontal?

Example :CURSOR:TY:HORIZONTAL? -> :CURSOR:TY:HORIZONTAL:TRACE 1; POSITION1 3.00;POSITION2 -3.00

:CURSor:TY:HORizontal:DY?

Function Queries the Y-axis value between the horizontal cursors in the T-Y display.

Syntax :CURSor:TY:HORizontal:DY?

Example :CURSOR:TY:HORIZONTAL:DY? -> :CURSOR:TY:HORIZONTAL:DY 3.000000E+00

Description When the linear scaling is ON, the scaled value is queried.

:CURSor:TY:HORizontal:POSition<x>

Function Sets the horizontal cursor position in the T-Y display or queries the current setting.

Syntax :CURSor:TY:HORizontal:POSition<x> {<NRf>} :CURSor:TY:HORizontal:POSition<x>? <x>=1 or 2 <NRf>=-4 to 4div (1/100 steps)

Example :CURSOR:TY:HORIZONTAL:POSITION1 2 :CURSOR:TY:HORIZONTAL:POSITION1? -> :CURSOR:TY:HORIZONTAL:POSITION1 2.00

Description The <NRf> value is accurate to two digits beyond the decimal.

:CURSor:TY:HORizontal:TRACe

Function Sets the waveform on which to use the horizontal cursor in the T-Y display or queries the current setting.

Syntax :CURSor:TY:HORizontal:TRACe {<NRf> | MATH<x>} :CURSor:TY:HORizontal:TRACe? <NRf>=1 to 4 (1 to 2 on the DL1720E) <x>=1 or 2 (1 on the DL1720E)

Example :CURSOR:TY:HORIZONTAL:TRACE 1 :CURSOR:TY:HORIZONTAL:TRACE? -> :CURSOR:TY:HORIZONTAL:TRACE 1

:CURSor:TY:HORizontal:Y<x>?

Function Queries the Y-axis value of the horizontal cursor in the T-Y display.

Syntax :CURSor:TY:HORizontal:Y<x>? <x>=1 or 2

Example :CURSOR:TY:HORIZONTAL:Y1? -> :CURSOR:TY:HORIZONTAL:Y1 -1.000000E+00

Description When the linear scaling is ON, the scaled value is queried.

:CURSor:TY:MARKer?

Function Queries all settings related to marker cursors in the T-Y display.

Syntax :CURSor:TY:MARKer?

Example :CURSOR:TY:MARKER? -> :CURSOR:TY:MARKER:M1:TRACE 1; POSITION -3.0000000; :CURSOR:TY:MARKER:M2:TRACE 2; POSITION-1.0000000; :CURSOR:TY:MARKER:M3:TRACE 3; POSITION 1.0000000; :CURSOR:TY:MARKER:M4:TRACE 4; POSITION 3.0000000

:CURSOR:TY:MARKER:DX<x>?

Function	Queries the X-axis value between the marker cursors in the T-Y display.
Syntax	:CURSOR:TY:MARKER:DX<x>? <x>=1 to 4
Example	:CURSOR:TY:MARKER:DX1? -> :CURSOR:TY:MARKER:DX1 0.0000000E+00
Description	<ul style="list-style-type: none"> • When the time base is set to internal clock The query is for the time between the markers in the time domain and the frequency between the markers in the frequency domain. • When the time base is set to external clock The number of points between the marker cursors is queried.

:CURSOR:TY:MARKER:DY<x>?

Function	Queries the physical value of the Y-axis difference between the marker cursors in the T-Y display.
Syntax	:CURSOR:TY:MARKER:DY<x>? <x>=1 to 4
Example	:CURSOR:TY:MARKER:DY2? -> :CURSOR:TY:MARKER:DY2 500.00000E-03
Description	When the linear scaling is ON, the scaled value is queried.

:CURSOR:TY:MARKER:M<x>?

Function	Queries all settings related to the specified marker cursor.
Syntax	:CURSOR:TY:MARKER:M<x>? <x>=1 to 4
Example	:CURSOR:TY:MARKER:M1? -> :CURSOR:TY:MARKER:M1:TRACE 1:POSITION -3.0000000

:CURSOR:TY:MARKER:M<x>:JUMP

Function	Jumps the marker cursor onto the zoom waveform display frame.
Syntax	:CURSOR:MARKER:M<x>:JUMP {Z1 Z2} <x>=1 to 4
Example	:CURSOR:TY:MARKER:M1:JUMP Z1
Description	The cursor jumps to the center position of the zoomed waveform.

:CURSOR:TY:MARKER:M<x>:POSITION

Function	Sets the X-axis position of the marker cursor in the T-Y display or queries the current setting.
Syntax	:CURSOR:TY:MARKER:M<x>:POSITION {<NRf>} :CURSOR:TY:MARKER:M<x>:POSITION? <x>=1 to 4 <NRf>=-5 to 5 div (10 div/displayed record length steps)
Example	:CURSOR:TY:MARKER:M1:POSITION -1 :CURSOR:TY:MARKER:M1:POSITION? -> :CURSOR:TY:MARKER:M1: POSITION -1.0000000

:CURSOR:TY:MARKER:M<x>:TRACE

Function	Sets the waveform on which to use the marker cursor in the T-Y display or queries the current setting.
Syntax	:CURSOR:TY:MARKER:M<x>:TRACE {<NRf> MATH<x>} :CURSOR:TY:MARKER:M<x>:TRACE? <x> of M<x>=1 to 4 <NRf>=1 to 4 (1 to 2 on the DL1720E) <x> of MATH<x>=1 or 2 (1 on the DL1720E)
Example	:CURSOR:TY:MARKER:M1:TRAC1 1 :CURSOR:TY:MARKER:M1:TRACE1? -> :CURSOR:TY:MARKER:M1:TRACE1 1

:CURSOR:TY:MARKER:X<x>?

Function	Queries the X-axis position of the marker cursor in the T-Y display.
Syntax	:CURSOR:TY:MARKER:X<x>? <x>=1 to 4
Example	:CURSOR:TY:MARKER:X1? -> :CURSOR:TY:MARKER:X1 -4.5000E-03
Description	<ul style="list-style-type: none"> • When the time base is set to internal clock The query is for the time in the time domain and frequency in the frequency domain. • When the time base is set to external clock The query is for the number of points with respect to delay 0 in the time domain and the number of points from the beginning of the memory in the frequency domain.

:CURSOR:TY:MARKER:Y<x>?

Function	Queries the Y-axis position of the marker cursor in the T-Y display.
Syntax	:CURSOR:TY:MARKER:Y<x>? <x>=1 to 4
Example	:CURSOR:TY:MARKER:Y1? -> :CURSOR:TY:MARKER:Y1 1.5000E-03
Description	When the linear scaling is ON, the scaled value is queried.

:CURSOR:TY:TYPE

Function	Sets the type of cursor in the T-Y display or queries the current setting.
Syntax	:CURSOR:TY:TYPE {OFF HORIZONTAL VERTICAL MARKER DEGREE} :CURSOR:TY:TYPE?
Example	:CURSOR:TY:TYPE HORIZONTAL :CURSOR:TY:TYPE? -> :CURSOR:TY:TYPE HORIZONTAL

:CURSOR:TY:VERTICAL?

Function	Queries all settings related to vertical cursors in the T-Y display.
Syntax	:CURSOR:TY:VERTICAL?
Example	:CURSOR:TY:VERTICAL -> :CURSOR:TY: VERTICAL:TRACE 1; POSITION1 -4.0000000; POSITION2 4.0000000

5.8 CURSor Group

:CURSor:TY:VERTical:DX?

Function Queries the X-axis value between vertical cursors in the T-Y display.

Syntax :CURSor:TY:VERTical:DX?

Example :CURSOR:TY:VERTICAL:DX? ->
:CURSOR:TY:VERTICAL:DX 2.50E-06

Description

- **When the time base is set to internal clock**
The query is for the time between the markers in the time domain and the frequency between the markers in the frequency domain.
- **When the time base is set to external clock**
The number of points between the marker cursors is queried.

:CURSor:TY:VERTical:DY?

Function Queries the Y-axis value between vertical cursors in the T-Y display.

Syntax :CURSor:TY:VERTical:DY?

Example :CURSOR:TY:VERTICAL:DY? ->
:CURSOR:TY:VERTICAL:DY 1.50E+03

Description When the linear scaling of the Y trace is ON, the scaled value is queried.

:CURSor:TY:VERTical:JUMP

Function Moves the vertical cursor in the T-Y display to the specified zoomed waveform.

Syntax :CURSor:TY:VERTical:JUMP {C1_Z1|C1_Z2|C_Z1|C2_Z2}

Example :CURSOR:TY:VERTICAL:JUMP C1_Z1

Description The cursor jumps to the center position of the zoomed waveform.
C1 and C2 represent vertical cursors, Cursor1 and Cursor2, respectively.

:CURSor:TY:VERTical:PERDt?

Function Queries the $1/\Delta T$ value between vertical cursors in the T-Y display.

Syntax :CURSor:TY:VERTical:PERDt?

Example :CURSOR:TY:VERTICAL:PERDT? ->
:CURSOR:TY:VERTICAL:PERDT 2.50E+06

Description When the specified trace is in the frequency domain, "NAN(Not A Number)" is returned.

:CURSor:TY:VERTical:POSition<x>

Function Sets the vertical cursor position in the T-Y display or queries the current setting.

Syntax :CURSor:TY:VERTical:POSition<x>
{<NRf>}
:CURSor:TY:VERTical:POSition<x>?
<x>=1 or 2
<NRf>=-5 to 5 div (10 div/displayed record length steps)

Example :CURSOR:TY:VERTICAL:POSITION1 2
:CURSOR:TY:VERTICAL:POSITION1? ->
:CURSOR:TY:VERTICAL:
POSITION1 2.00E+00

:CURSo:TY:VERTical:TRACE

Function Sets the target waveform of the vertical cursor of the T-Y display or queries the current setting.

Syntax :CURSor:TY:VERTical:TRACe
{<NRf>|MATH<x>|PODA|PODB|PODA_PODB|ALL}
:CURSor:TY:VERTical:TRACe?
<NRf>=1 to 4 (1 to 2 on the DL1720E)
<x>=1 or 2 (1 on the DL1720E)

Example :CURSOR:TY:VERTICAL:TRACE 1
:CURSOR:TY:VERTICAL:TRACE? ->
:CURSOR:TY:VERTICAL:TRACE 1

:CURSor:TY:VERTical:X<x>?

Function Queries the X-axis position of the vertical cursor in the T-Y display.

Syntax :CURSor:TY:VERTical:X<x>?
<x>=1 or 2

Example :CURSOR:TY:VERTICAL:X1? ->
:CURSOR:TY:VERTICAL:X1 -2.50E-06

Description

- **When the time base is set to internal clock**
The query is for the time in the time domain and frequency in the frequency domain.
- **When the time base is set to external clock**
The query is for the number of points with respect to delay 0 in the time domain and the number of points from the beginning of the memory in the frequency domain.

:CURSor:TY:VERTical:Y<x>?

Function Queries the Y-axis position of the vertical cursor in the T-Y display.

Syntax :CURSor:TY:VERTical:Y<x>?
<x>=1 or 2

Example :CURSOR:TY:VERTICAL:Y1? ->
:CURSOR:TY:VERTICAL:Y1 2.50E+03

:CURSor:XY?

Function Queries all settings related to the cursors in the X-Y display.

Syntax CURSor:XY?

Example CURSOR:XY? -> :CURSOR:XY:TYPE OFF;
HORIZONTAL:TRACE XY1;
POSITION1 3.00;POSITION2 -3.00;;
CURSOR:XY:VERTICAL:TRACE XY1;
POSITION1 -3.00;POSITION2 3.00;;
CURSOR:XY:MARKER:TRACE XY1;
POSITION -3.0000000

:CURSor:XY:HORizontal?

Function Queries all settings related to the horizontal cursors in the X-Y display.

Syntax :CURSor:XY:HORizontal?

Example :CURSOR:XY:HORIZONTAL? ->
:CURSOR:XY:HORIZONTAL:TRACE XY1;
POSITION1 3.00;POSITION2 -3.00

:CURSor:XY:HORizontal:DY?

Function Queries the Y-axis value of the horizontal cursor of the X-Y display.

Syntax :CURSor:XY:HORizontal:DY?

Example :CURSOR:XY:HORIZONTAL:DY? ->
:CURSOR:XY:HORIZONTAL:
DY 3.0000000E+00

Description When the linear scaling is ON, the scaled value is queried.

:CURSOR:XY:HORIZONTAL:POSITION<x>

Function Sets the horizontal cursor position of the X-Y display or queries the current setting.

Syntax `:CURSOR:XY:HORIZONTAL:POSITION<x>`
`{<NRf>}`
`:CURSOR:XY:HORIZONTAL:POSITION<x>?`
`<x>=1 or 2`
`<NRf>=-4 to 4 div (1/100 steps)`

Example `:CURSOR:XY:HORIZONTAL:POSITION1 2`
`:CURSOR:XY:HORIZONTAL:POSITION1? ->`
`:CURSOR:XY:HORIZONTAL:`
`POSITION1 2.00`

:CURSOR:XY:HORIZONTAL:TRACE

Function Sets the waveform on which to use the H cursor in the X-Y display or queries the current setting (DL1740E/DL1740EL only).

Syntax `:CURSOR:XY:HORIZONTAL:TRACE`
`{XY1|XY2}`
`:CURSOR:XY:HORIZONTAL:TRACE?`

Example `:CURSOR:XY:HORIZONTAL:TRACE XY1`
`:CURSOR:XY:HORIZONTAL:TRACE? ->`
`:CURSOR:XY:HORIZONTAL:TRACE XY1`

:CURSOR:XY:HORIZONTAL:Y?

Function Queries the Y-axis value of the horizontal cursor of the X-Y display.

Syntax `:CURSOR:XY:HORIZONTAL:Y?`

Example `:CURSOR:TY:HORIZONTAL:Y? >`
`:CURSOR:TY:HORIZONTAL:`
`Y -1.5000000E+00`

Description When the linear scaling is ON, the scaled value is queried.

:CURSOR:XY:MARKER?

Function Queries all settings related to the marker cursors in the X-Y display.

Syntax `:CURSOR:XY:MARKER?`

Example `:CURSOR:XY:MARKER?-> :CURSOR:XY:`
`MARKER:DISPLAY 1;TRACE XY1;`
`POSITION -3.0000000`

:CURSOR:XY:MARKER:POSITION

Function Sets the X-axis position of the marker cursor in the X-Y display or queries the current setting.

Syntax `:CURSOR:XY:MARKER:POSITION <NRf>}`
`:CURSOR:XY:MARKER:POSITION?`
`<NRf>=-5 to 5 div (10 div/displayed record`
`length steps)`

Example `:CURSOR:XY:MARKER:POSITION -1`
`:CURSOR:XY:MARKER:POSITION? ->`
`:CURSOR:XY:MARKER:`
`POSITION -1.0000000`

:CURSOR:XY:MARKER:T?

Function Queries the time value of the marker cursor in the X-Y display.

Syntax `:CURSOR:XY:MARKER:T?`

Example `:CURSOR:XY:MARKER:T? ->`
`:CURSOR:XY:MARKER:T 100.00E-03`

:CURSOR:XY:MARKER:TRACE

Function Sets the waveform on which to use the marker cursor in the X-Y display or queries the current setting (DL1740E/DL1740EL only).

Syntax `:CURSOR:XY:MARKER:TRACE {XY1|XY2}`
`:CURSOR:XY:MARKER:TRACE?`

Example `:CURSOR:XY:MARKER:TRACE XY1`
`:CURSOR:XY:MARKER:TRACE? ->`
`:CURSOR:XY:MARKER:TRACE XY1`

:CURSOR:XY:MARKER:X?

Function Queries the X-axis position of the marker cursor in the X-Y display.

Syntax `:CURSOR:XY:MARKER:X?`

Example `:CURSOR:XY:MARKER:X1? ->`
`:CURSOR:XY:MARKER:X -4.5000E-03`

Description When the linear scaling is ON, the scaled value is queried.

:CURSOR:XY:MARKER:Y?

Function Queries the Y-axis position of the marker cursor in the X-Y display.

Syntax `:CURSOR:XY:MARKER:Y?`

Example `:CURSOR:XY:MARKER:Y? ->`
`:CURSOR:XY:MARKER:Y 1.5000E-03`

Description When the linear scaling is ON, the scaled value is queried.

:CURSOR:XY:TYPE

Function Sets the cursor type of the X-Y display or queries the current setting.

Syntax `:CURSOR:XY:TYPE`
`{OFF|HORIZONTAL|VERTICAL|MARKER}`
`:CURSOR:XY:TYPE?`

Example `:CURSOR:XY:TYPE VERTICAL`
`:CURSOR:XY:TYPE? ->`
`:CURSOR:XY:TYPE VERTICAL`

:CURSOR:XY:VERTICAL?

Function Queries all settings related to vertical cursors in the X-Y display.

Syntax `:CURSOR:XY:VERTICAL?`

Example `:CURSOR:XY:VERTICAL ->`
`:CURSOR:XY:VERTICAL:TRACE XY1;`
`POSITION1 -3.00;POSITION2 3.00`

:CURSOR:XY:VERTICAL:DX?

Function Queries the X-axis value between the vertical cursors in the X-Y display.

Syntax `:CURSOR:XY:VERTICAL:DX?`

Example `:CURSOR:XY:VERTICAL:DX? ->`
`:CURSOR:XY:VERTICAL:DX 2.50E-06`

Description When the linear scaling of the X trace is ON, the scaled value is queried.

:CURSOR:XY:VERTICAL:POSITION<x>

Function Sets the vertical cursor position of the X-Y display or queries the current setting.

Syntax `:CURSOR:XY:VERTICAL:POSITION<x>`
`{<NRf>}`
`:CURSOR:XY:VERTICAL:POSITION<x>?`
`<x>=1 or 2`
`<NRf>=-4 to 4 div (1/100 steps)`

Example `:CURSOR:XY:VERTICAL:POSITION1 2`
`:CURSOR:XY:VERTICAL:POSITION1? ->`
`:CURSOR:XY:VERTICAL:`
`POSITION1 2.00E+00`

5.8 CURSor Group

CURSor:XY:VERTical:TRACe

Function Sets the waveform on which to use the vertical cursor in the X-Y display or queries the current setting (DL1740E/DL1740EL only).

Syntax :CURSor:XY:VERTical:TRACe {XY1|XY2}
:CURSor:XY:VERTical:TRACe?

Example :CURSOR:XY:VERTICAL:TRACE
XY1:CURSOR:XY:VERTICAL:TRACE? ->
:CURSOR:XY:VERTICAL:TRACE XY1

:CURSor:XY:VERTical:X<x>?

Function Queries the X-axis position of the vertical cursor in the X-Y display.

Syntax :CURSor:XY:VERTical:X<x>?
<x>=1 or 2

Example :CURSOR:XY:VERTICAL:X1? ->
:CURSOR:XY:VERTICAL:X1 -2.50E-06

5.9 DISPlay Group

The commands in the DISPlay group are used to set or query the display parameters. This allows you to make the same settings that can be made using the Graph Color menu of MISC.

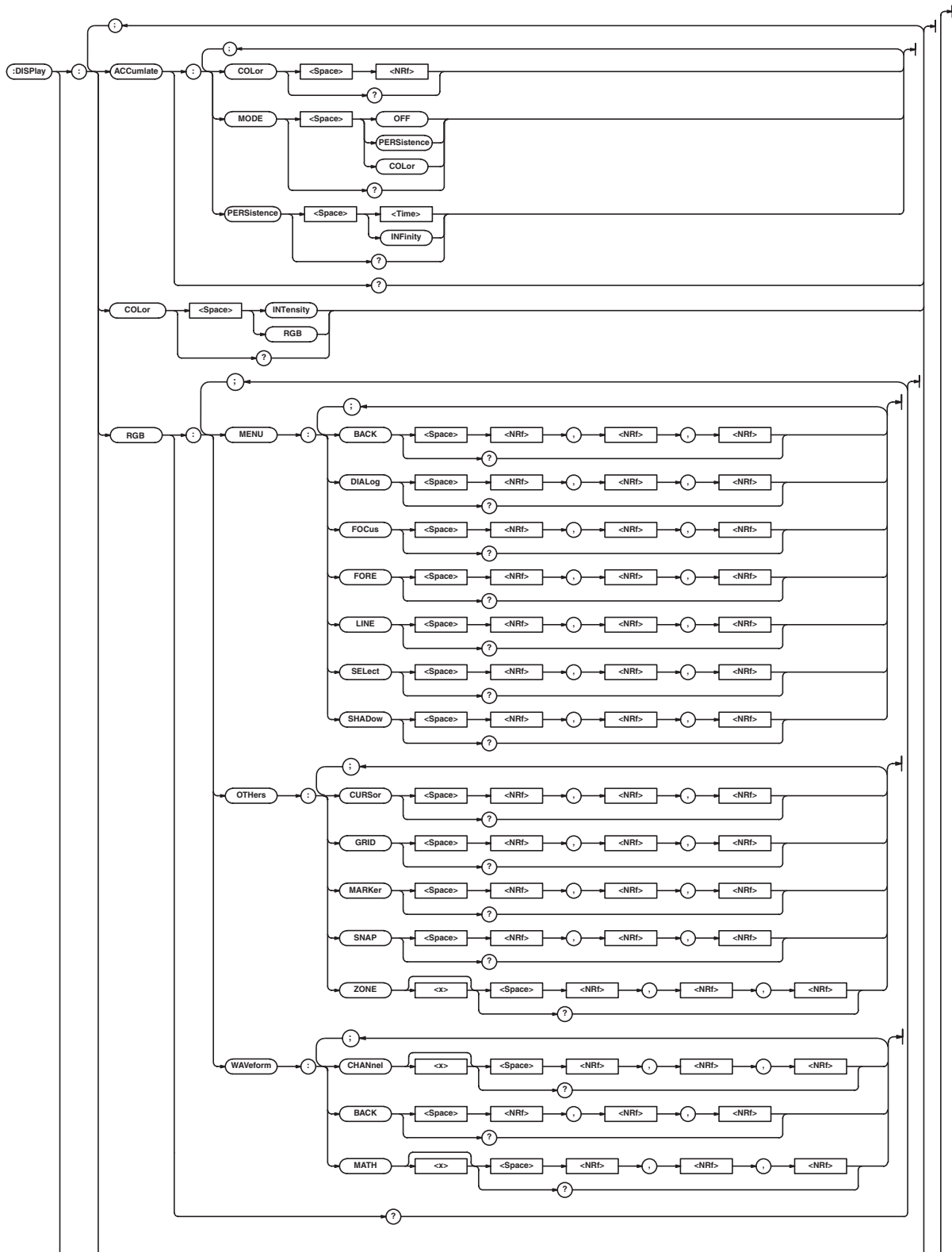

5.9 DISPlay Group

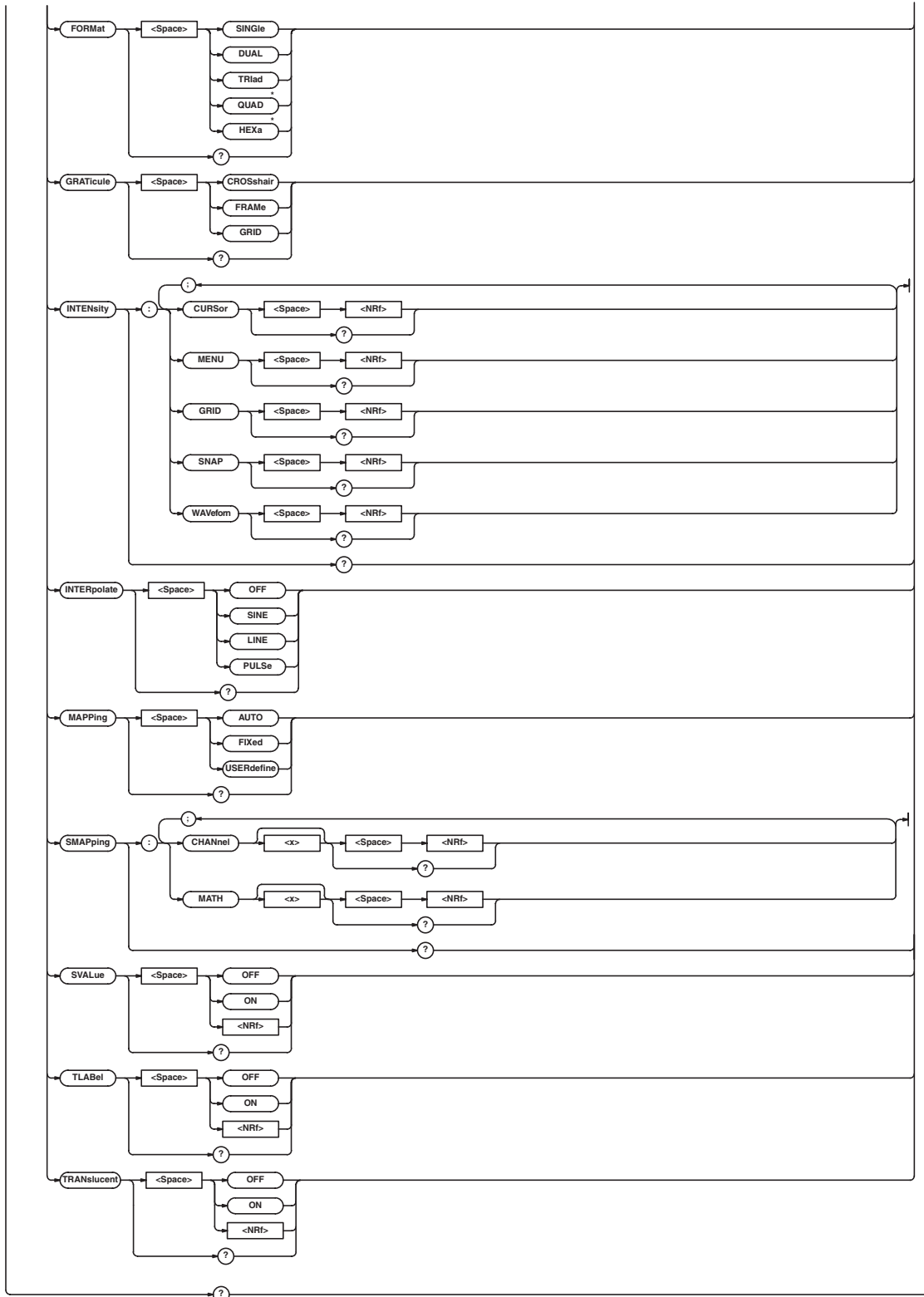

* For use on the DL1740E/DL1740EL.

:DISPlay?

Function Queries all display settings.
 Syntax :DISPlay?
 Example :DISPLAY? -> :DISPLAY:FORMAT QUAD;
 INTERPOLATE SINE;GRATICULE GRID;
 SVALUE 0;TLABEL 0;ACCUMLATE:
 MODE OFF;PERSISTENCE 100.0E-03;
 COLOR 16;:DISPLAY:TRANSLUCENT 0;
 MAPPING AUTO;SMAPPING:CHANNEL1 0;
 CHANNEL2 1;CHANNEL3 2;CHANNEL4 3;
 MATH1 4;MATH2 5;:DISPLAY:
 COLOR INTENSITY;INTENSITY:MENU 10;
 WAVEFORM 10;SNAP 10;GRID 10;
 CURSOR 10;:DISPLAY:RGB:MENU:
 FORE 15,15,15;BACK 0,0,7;
 FOCUS 0,0,7;SELECT 0,7,15;
 DIALOG 7,7,7;SHADOW 0,0,0;
 LINE 15,15,15;:DISPLAY:RGB:
 WAVEFORM:CHANNEL1 15,15,0;
 CHANNEL2 0,15,0;CHANNEL3 15,0,15;
 CHANNEL4 0,15,15;MATH1 15,0,0;
 MATH2 15,7,0;BACK 0,0,0;:DISPLAY:
 RGB:OTHERS:SNAP 15,15,15;
 ZONE1 0,0,15;ZONE2 15,4,11;
 ZONE3 11,15,4;ZONE4 0,7,15;
 GRID 8,8,8;CURSOR 13,13,13;
 MARKER 15,15,15

:DISPlay:ACCumulate?

Function Queries all accumulation settings.
 Syntax :DISPlay:ACCumulate?
 Example :DISPLAY:ACCUMULATE? ->
 :DISPLAY:ACCUMULATE:MODE OFF;
 PERSISTENCE 100.0E-03;COLOR 16

:DISPlay:ACCumulate:COLor

Function Sets/queries the color grading width.
 Syntax :DISPlay:ACCumulate:COLor {<NRF>}
 :DISPlay:ACCumulate:COLor?
 <NRF>=2 to 2048 (in steps of 2ⁿ)
 Example :DISPLAY:ACCUMULATE:COLOR 16
 :DISPLAY:ACCUMULATE:COLOR? ->
 :DISPLAY:ACCUMULATE:COLOR 16

:DISPlay:ACCumulate:MODE

Function Selects/queries the accumulation mode.
 Syntax :DISPlay:ACCumulate:MODE {COLor|
 OFF|PERSistence}
 :DISPlay:ACCumulate:MODE?
 Example :DISPLAY:ACCUMULATE:
 MODE PERSISTENCE
 :DISPLY:ACCUMULATE:MODE? ->
 :DISPLAY:ACCUMULATE:
 MODE PERSISTENCE

:DISPlay:ACCumulate:PERSistence

Function Sets/queries the accumulation time.
 Syntax :DISPlay:ACCumulate:PERSistence
 {<Time>|INFINITY}
 :DISPlay:ACCumulate:PERSistence?
 <Time>=100 ms to 50 s (in 1-2-5 steps)
 Example :DISPLA:ACCUMULATE:
 PERSISTENCE 100MS
 :DISPLAY:ACCUMULATE:PERSISTENCE? ->
 :DISPLAY:ACCUMULATE:
 PERSISTENCE 100.0E-03

:DISPlay:COLor

Function Sets whether to change the screen color using
 RGB or brightness or queries the crrnt setting.
 Syntax :DISPlay:COLor {INTensity|RGB}
 :DISPlay:COLor?
 Example :DISPLAY:COLOR INTENSITY
 :DISPLAY:COLOR? -> :DISPLAY:
 COLOR INTENSITY

:DISPlay:RGB?

Function Queries all settings related to the screen color.
 Syntax :DISPlay:RGB?
 Example :DISPLAY:RGB? -> :DISPLAY:RGB:MENU:
 FORE 15,15,15;BACK 0,0,7;
 FOCUS 0,0,7;SELECT 0,7,15;
 DIALOG 7,7,7;SHADOW 0,0,0;
 LIE 15,15,15;:DISPLAY:RGB:
 WAVEFORM:CHANNEL1 15,15,0;
 CHANNEL2 0,15,0;CHANNEL3 15,0,15;
 CHANNEL4 0,15,15;MATH1 15,0,0;
 MATH2 15,7,0;BACK 0,0,0;:DISPLAY:
 RGB:OTHERS:SNAP 15,15,15;
 ZONE1 0,0,15;ZONE2 15,4,11;
 ZONE3 11,15,4;ZONE4 0,7,15;
 GRID 8,8,8;CURSOR 13,13,13;
 MARKER 15,15,15

:DISPlay:RGB:MENU?

Function Queries all settings related to colors used in the
 menu.
 Syntax :DISPlay:RGB:MENU?
 Example :DISPLAY:RGB:MENU? ->
 :DISPLAY:RGB:MENU:FORE 15,15,15;
 BACK 0,0,7;FOCUS 0,0,7;
 SELECT 07,15;DIALOG 7,7,7;
 SHADOW 0,0,0;LINE 15,15,15

**:DISPlay:RGB:MENU: {BACK | DIALog |
FOCus | FORE | LINE | SElect | SHADow}**

Function Sets the color of the characters, background,
 focus, select, dialog, shade, and lines of the
 menu or queries the current setting.
 Syntax :DISPlayRGB:MENU: {BACK|DIALog|
 FOCus|FORE|LINE|SElect|SHADow}
 {<NRF>,<NRF>,<NRF>}
 :DISPlay:RGB:MENU: {BACK|DIALog|
 FOCus|FORE|LINE|SElect|SHADow}?
 <NRF>=0 to 15 (R, G, B, in that order)
 Example :DISPlay:RGB:MENU:BACK 15,15,15
 :DISPlay:RGB:MENU:BACK? ->
 :DISPlay:RGB:MEN:BACK 15,15,15
 Description Set the ":DISPlay:COLor" command to
 "RGB" before executing this command.

:DISPlay:RGB:OTHERs?

Function Queries all settings related to the colors of other
 items.
 Syntax :DISPlay:RGB:OTHERs?
 Example :DISPLAY:RGB:OTHERS? ->
 :ISPLAY:RGB:OTHERS:SNAP 15,15,15;
 ZONE1 0,0,15;ZONE2 15,4,11;
 ZONE3 11,15,4;ZONE4 0,7,15;
 GRID 8,8,8;CURSOR 13,13,13;
 MARKER 15,15,15

5.9 DISPlay Group

:DISPlay:RGB:OTHERs:{CURSOR|GRID|MARKER|SNAP|ZONE<x>}

Function Sets the color for cursrs, graticule, markers, and snapshot waveforms or queries the current setting.

Syntax :DISPlay:RGB:OTHERs:{CURSOR|GRID|MARKER|SNAP|ZONE<x>} {<Nrf>,<Nrf>,<Nrf>} :DISPlay:RGB:OTHERs:{CURSOR|GRID|MARKER|SNAP|ZONE<x>}? <x>=1 or 2 <Nrf>=0 to 15 (R, G, B, in that order)

Example :DISPLAY:RGB:OTHERS:CURSOR 0,0,0 :DISPLAY:RGB:OTHERS:CURSOR? -> :DISPLAY:RGB:OTHERS:CURSOR 0,0,0

Description Set the “:DISPlay:COLor” command to “RGB” before executing this command.

:DISPlay:RGB:WAVEform?

Function Queries all settings related to the waveform colors.

Syntax :DISPlay:RGB:WAVEform?

Example :DISPLAY:RGB:WAVEFORM? -> :DISPLAY:RGB:WAVEFORM: CHANNEL1 15,15,0;CHANNEL2 ,15,0; CHANNEL3 15,0,15;CHANNEL4 0,15,15; MATH1 15,0,0;MATH2 15,7,0; BACK 0,0,0

:DISPlay:RGB:WAVEform:{CHANnel<x>|BACK|MATH<x>}

Function Sets the color of the channel, background, computation channel, and logic channel or queries the current setting.

Syntax :DISPlay:RGB:WAVEform:{CHANnel<x>|BACKMATH<x>} {<Nrf>,<Nrf>,<Nrf>} :DISPlay:RGB:WAVEform:{CHANnel<x>|BACK|MATH<x>} <x> of CHANnel<x>=1 to 4 (1 to 2 on the DL1720E) <x> of MATH<x>=1 or 2 (1 on the DL1720E) <Nrf>=0 to 15 (in the order R, G, and B)

Example :DISPLAY:RGB:WAVEFORM: CHANNEL1 0,0,0 :DISPLAY:RGB:WAVEFORM:CHANNEL1? -> :DISPLAY:RGB:WAVEFORM: CHANNEL1 0,0,0

Description Execute this command after setting “:DISPlay:COLor” to RGB.

:DISPlay:FORMat

Function Sets the display format or queries the current setting.

Syntax :DISPlay:FORMat {SINGle|DUAL|TRIad|QUAD|HEXa} :DISPlay:FORMat?

Example :DISPLAY:FORMAT QUAD :DISPLAY:FORMAT? -> :DISPLAY:FORMAT QUAD

Description QUAD and HEXa are not available on the DL1720E.

:DISPlay:GRATICule

Function Sets/queries the graticule.

Syntax :DISPlay:GRATICule {CROSShair|FRAME|GRID} :DISPlay:GRATICule?

Example :DISPLAY:GRATICULE GRID :DISPLAY:GRATICULE? -> :DISPLAY:GRATICULE GRID

:DISPlay:INTENsity?

Function Queries all settings related to the brightness of the displayed items.

Syntax :DISPlay:INTENsity?

Example :DISPLAY:INTENSITY? -> :DISPLAY:INTENSITY:MENU 10; WAVEform 10;SNAP 10;GRID 10; CURSOR 10

:DISPlay:INTENsity:{CURSOR|MENU|GRID|SNAP|WAVEform}

Function Sts the brightness of each display item or queries the current setting.

Syntax :DISPlay:INTENsity:{CURSOR|MENU|GRID|SNAP|WAVEform} {<Nrf>} :DISPlay:INTENsity:{CURSOR|MENU|GRID|SNAP|WAVEform}? <Nrf>=1 to 15

Example (The following example is for the cursor.) :DISPLAY:INTENSITY:CURSOR 6 :DISPLAY:INTENSITY:CURSOR? -> :DISPLAY:INTENSITY:CURSOR 6

Description Set the “:DISPlay:COLor” command to “INTensity” before executing this command.

:DISPlay:INTERpolate

Fncion Selects/queries the interpolation method.

Syntax :DISPlay:INTERpolate {LINE|OFF|PULSE|SINE} :DISPlay:INTERpolate?

Example :DISPLAY:INTERPOLATE LINE :DISPLAY:INTERPOLATE? -> :DISPLAY:INTERPOLATE LINE

:DISPlay:MAPPING

Function Sets/queries the mapping mode.

Synta :DISPlay:MAPPING {AUTO|FIXed|USERdefine} :DISPlay:MAPPING?

Example :DISPLAY:MAPPING AUTO :DISPLAY:MAPPING? -> :DISPLAY:MAPPING AUTO

:DISPlay:SMAPPING?

Function Queries all settings relating to the assignment of the waveforms to the split window.

Syntax :DISPlay:SMAPPING?

Example :DISPLAY:SMAPPING? -> :DISPLAY:SMAPPING:CHANNEL1 0 CHANNEL2 1;CHANNEL3 2;CHANNEL4 3; MATH1 4;MATH2 5

**:DISPlay:SMAPping:{CHANnel<x>|MATH<x>}
(Set Mapping)**

Function Sets the mapping of the waveform to the split screen or queries the current setting.

Syntax :DISPlay:SMAPping:{CHANnel<x>|
MATH<x>} {<NRf>}

:DISPlay:SMAPping:{CHANnel<x>|
MATH<x>}?
<x> of CHANnel<x>=1 to 4 (1 to 2 on the
DL1720E)
<x> of MATH<x>=1 or 2 (1 on the DL1720E)
<NRf>=0 to 5 (0 to 2 on the DL1720E)

Example :DISPLAY:SMAPPING:CHANNEL1 0
:DISPLAY:SMAPPING:CHANNEL1? ->
:DISPLAY:SMAPPING:CHANNEL1 0

:DISPlay:SVALue (Scale VALUE)

Function Selects/queries whether scaling values are displayed.

Syntax :DISPlay:SVALue {<Boolean>}
:DISPlay:SVALue?

Example :DISPLAY:SVALUE OFF
:DISPLAY:SVALUE? ->
:DISPLAY:SVALUE 0

:DISPlay:TLABel (Trace LABEL)

Function Selects/queries whether waveform labels are displayed.

Syntax :DISPlay:TLABel {<Boolean>}
:DISPlay:TLABel?

Example :DISPLAY:TLABEL ON
:DISPLAY:TLABEL? ->
:DISPLAY:TLABEL 1

Description You can set a user defined waveform label using the ":CHANnel<x>LABel" command.

:DISPlay:TRANslucent

Function Sets/queries the ON/OFF condition of the translucent mode of the pop-up menu.

Syntax :DISPlay:TRANslucent {<Boolean>}
:DISPlay:TRANslucent?

Example :DISPLAY:TRANSLUCEENT ON
:DISPLAY:TRANSLUCEENT? ->
:DISPLAY:TRANSLUCEENT 1

5.10 FILE Group

5.10 FILE Group

The commands in this group deal with the saving of data to the storage medium and loading of the saved data. This allows you to make the same settings and queries that can be made using FILE.

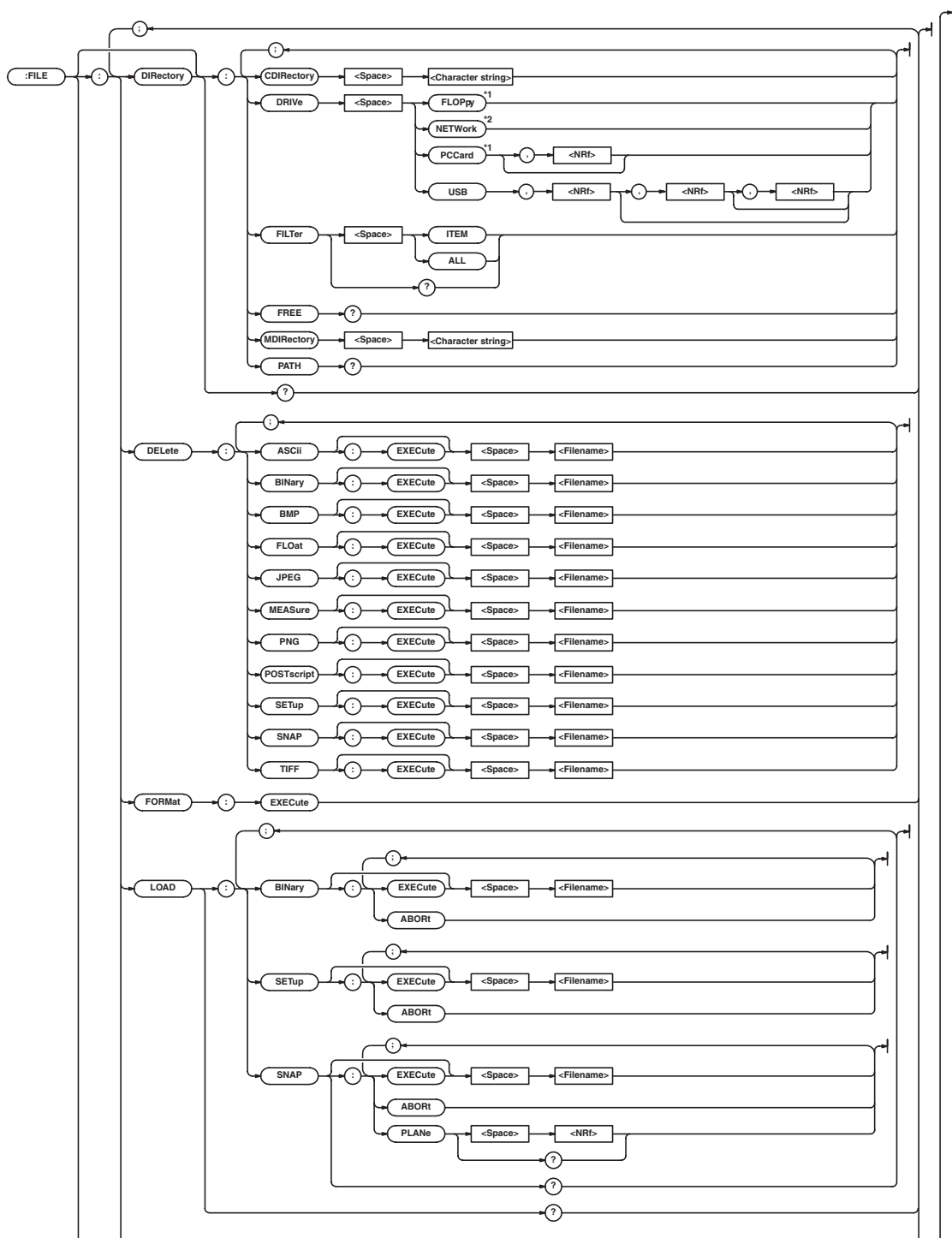

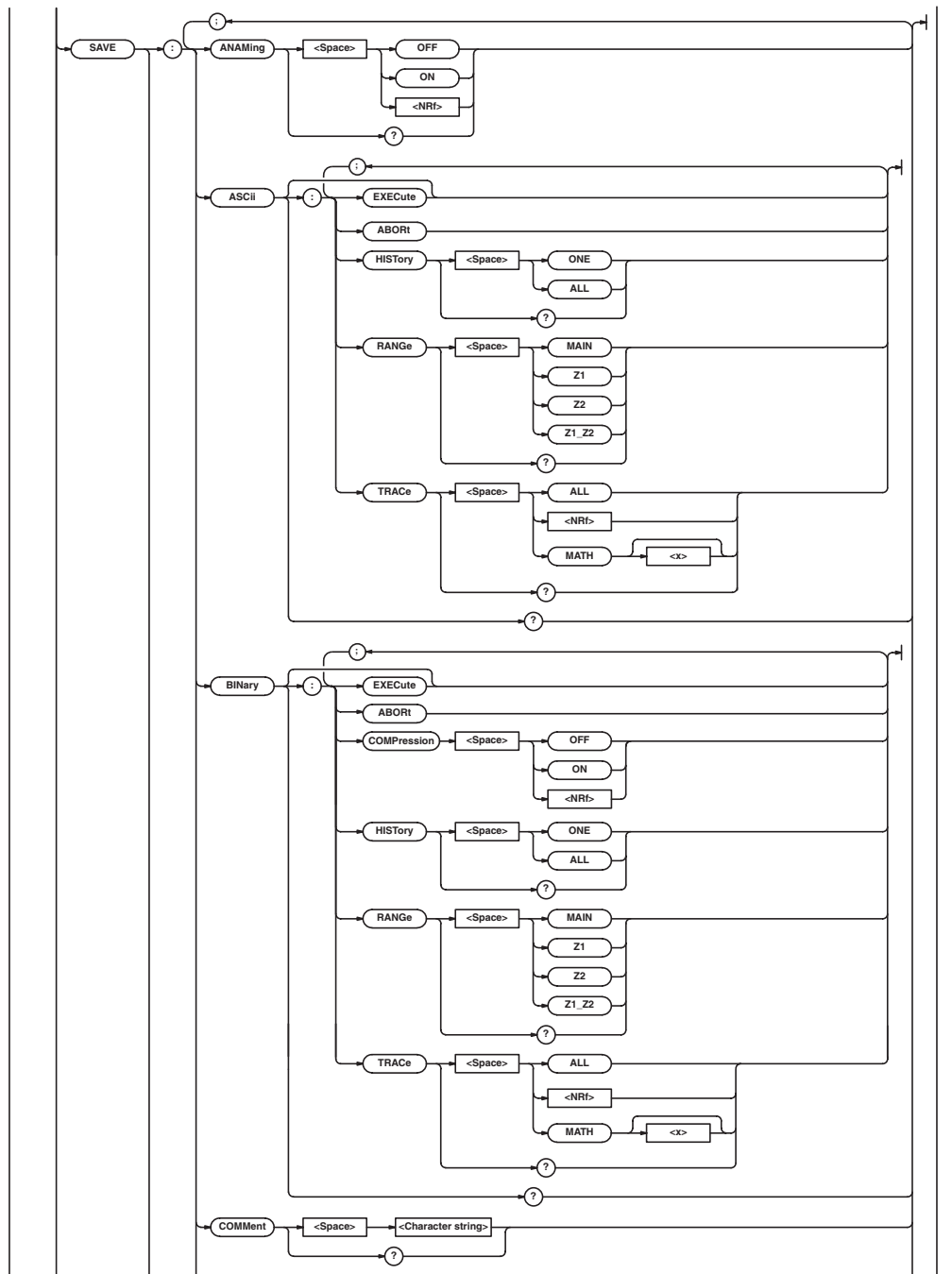

5.10 FILE Group

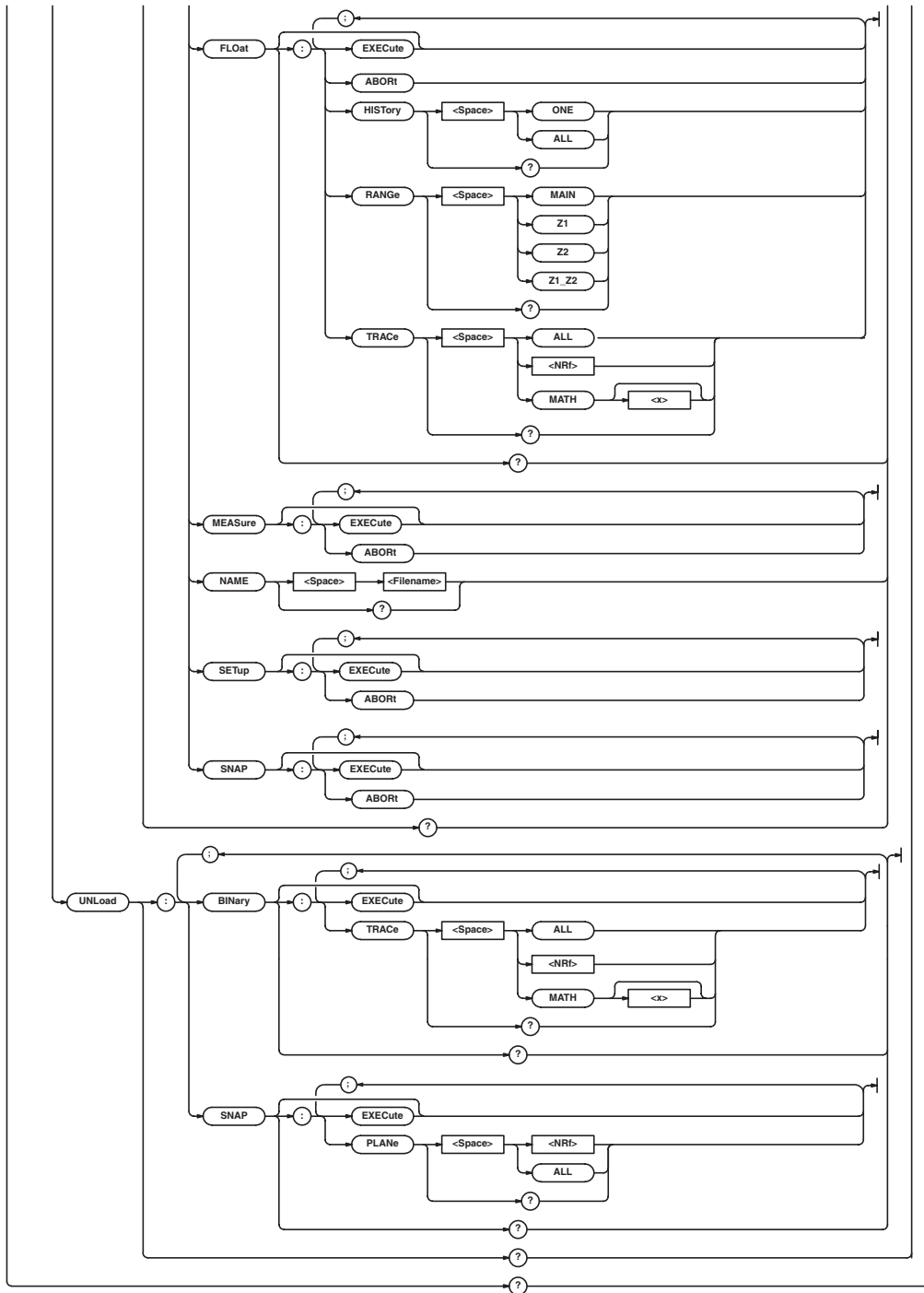

*1 "FLOppy" can be used when the built-in floppy disk drive is available; "PCCard" can be used when the built-in PC card interface is available.

*2 "NETWork" can be used when the Ethernet interface (option) is installed.

:FILE?

Function Queries the settings for the specified storage medium.

Syntax **:FILE?**

Example **:FILE? -> :FILE:DIRECTORY:
FILTER ITEM;:FILE:SAVE:BINARy:
TRACE 1;RANGE MAIN;HISTORY ONE;
COMPRESSION 0;:FILE:ASCIi:TRACE 1;
RANGE MAIN;HISTORY ONE;:FILE:FLOAt:
TRACE 1;RANGE MAIN;HISTORY ONE;:
SAVE:ANAMING 0;:NAME "SAVED1";:
COMMENT "TEST1";:FILE:LOAD:SNAP:
PLANE 1;:FILE:UNLOAD:BINARy:
TRACE 1;FILE:UNLOAD:SNAP:PLANE 1;:
FILE:COPIY:DIStINATION:
DRIVE FLOPPY;:FILE:FORMat:TYPE HD14**

:FILE:DELEte:{ASCIi|BINARy|BMP|FLOAt|JPEG|MEASure|PNG|POSTscript|SETup|SNAP|TIFF}[:EXECute]

Function Executes the deletion of the data file. This is an overlap command.

Syntax **:FILE:DELEte:{ASCIi|BINARy|BP|FLOAt|JPEG|MEASure|PNG|POSTscript|SETup|SNAP|TIFF}[:EXECute]
<Filename>**

Example (The following is an example for the setup data.)
:FILE:DELEte:SETUP "COPIED1"

Description The target medium to be deleted is selected using the **:FILE:DIRectory:DRIVE** command.

:FILE:DIRectry?

Function Queries all settings related to the specified directory.

Syntax **:FILE:DIRectory?**

Example **:FILE:DIRectory? ->
:FILE:DIRectory:FILTEr ITEM**

**:FILE[:DIRectory]:CDIRectory
(Change Directory)**

Function Changes the target directory.

Syntax **:FILE[:DIRectory]:CDIRectory
<Character string>
<Character string>=Up to 14 characters**

Example **:FILE[:DIRectory]:CDIRectory "NO_1"**

:FILE[:DIRectory]:DRIVE

Function Sets the specified storage medium.

Syntax **:FILE[:DIRectory]:DRIVE{FLOPPy|NETWork|PCCard[,<NRf>]|USB,<NRf>[,<NRf>][,<NRf>]}**
The first <NRf> of PCCard = Partitions (0 to 3)
USB's initial <NRf> = USB address
USB's 2nd <NRf> = partition (0 to 3) or LUN (logical unit number: 0 to 3)
USB's 3rd <NRf> = partition (0 to 3) when LUN specified for 2nd <NRf>

Example **:FILE[:DIRectory]:DRIVE PCCard,0**

Description If the drive does not contain partitions, omit the second <NRf>. "FLOPPy" can be used when the built-in floppy disk drive is available; "PCCard" can be used when the built-in PC card drive is available. "NETWork" can be used when the Ethernet interface (option) is installed. USB's 2nd and 3rd <NRf> can be omitted when not delimited by partitions or LUN.

:FILE[:DIRectory]:FILTEr

Function Sets the filter (limits the target files) or queries the current setting.

Syntax **:FILE[:DIRectory]:FILTEr {ITEM|ALL}**

Example **:FILE[:DIRectory]:FILTEr?
:FILE[:DIRectory]:FILTEr ITEM**

:FILE[:DIRectory]:FREE?

Function Queries the free disk space (bytes) on the specified storage medium.

Syntax **:FILE[:DIRectory]:FREE?**

Example **:FILE:DIRectory:FREE? ->
:FILE:DIRectory:FREE 65536**

**:FILE[:DIRectory]:MDIRectory
(Make Directory)**

Function Creates a directory under the specified directory. This is an overlap command.

Syntax **:FILE[:DIRectory]:MDIRectory
<Character string>
<Character string>=Up to 14 characters**

Example **:FILE:DIRectory:MDIRectory "NO_1"**

:FILE[:DIRectory]:PATH?

Function Queries the specified directory.

Syntax **:FILE[:DIRectory]:PATH?**

Example **:FILE[:DIRectory]:PATH? ->
:FILE[:DIRectory]:PATH "PATH=FD0"**

:FILE:FORMat:EXECute

Function Formats the floppy disk. This is an overlap command.

Syntax **:FILE:FORMat:EXECute**

Example **:FILE:FORMat:EXECUTE**

:FILE:LOAD?

Function Queries all settings related to file loading.

Syntax **:FILE:LOAD?**

Example **:FILE:LOAd? ->
:FILE:LOAD:SNAP:PLANE 1**

:FILE:LOAD:{BINARy|SETup|SNAP}:ABORt

Function Aborts loading the data.

Syntax **:FILE:LOAD:{BINARy|SETup|SNAP}
:ABORt**

Example (The following example is for the setup data.)
:FILE:LOAD:SETUP:ABORt

**:FILE:LOAD:{BINARy|SETup|SNAP}
[:EXECute]**

Function Loads the data. This is an overlap command.

Syntax **:FILE:LOAD:{BINARy|SETup|SNAP}
[:EXECute] <Filename>**

Example (The following example is for the setup data.)
:FILE:LOAD:SETUP:EXECUTE "CASE1"

:FILE:LOAD:SNAP?

Function Queries all settings related to the loading of the snapshot waveform.

Syntax **:FILE:LOAD:SNAP?**

Example **:FILE:LOAD:SNAP? ->
:FILE:LOAD:SNAP:PLANE 1**

5.10 FILE Group

:FILE:LOAD:SNAP:PLANE

Function Sets the plane number of the snapshot (Snap 1 to 4) waveform or queries the current setting.

Syntax `:FILE:LOAD:SNAP:PLANE {<NRF>}`
`:FILE:LOAD:SNAP:PLANE?`
`<NRF>=1 to 4`

Example `:FILE:LOAD:SNAP:PLANE 1`
`:FILE:LOAD:SNAP:PLANE? ->`
`:FILE:LOAD:SNAP:PLANE 1`

:FILE:SAVE?

Function Queries all settings related to data saving.

Syntax `:FILE:SAVE?`

Example `:FILE:SAVE? -> :FILE:SAVE:BINARy:`
`TRACe 1;RANGe MAIN;HISTORy ONE;`
`COMPRESSION ON;FILE:ASCIi:TRACe 1;`
`RANGe MAIN;HISTORy ONE;;FILE:`
`FLOAT:TRACe 1;RANGe MAIN;`
`HISTORy ONE;;SAVE:ANAMING OFF;;`
`NAME "SAVED1";:COMENT "TEST1"`

:FILE:SAVE:ANAMing

Function Turns ON/OFF the auto naming function of file names of the saved data or queries the current setting.

Syntax `:FILE:SAVE:ANAMing {<Boolean>}`
`:FILE:SAVE:ANAMing?`

Example `:FILE:SAVE:ANAMING ON`
`:FILE:SAVE:ANAMING? ->`
`:FILE:SAVE:ANAMING 1`

:FILE:SAVE:{ASCIi|BINARy|FLOat}?

Function Queries all settings related to various types of saving data.

Syntax `:FILE:SAVE:{ASCIi|BINARy|FLOat}?`

Example `:FILE:SAVE:BINARy? -> :FILE:SAVE:`
`BINARy:TRACe 1;RANGe MAIN;`
`HISTORy ONE;COMPRESSION ON`

:FILE:SAVE:{ASCIi|BINARy|FLOat|MEASure|SETup|SNAP}:ABORT

Function Aborts saving the various types of data.

Syntax `:FILE:SAVE:{ASCIi|BINARy|FLOat|`
`MEASure|SETup|SNAP}:ABORT`

Example (The following example is for the waveform data.)
`:FILE:SAVE:BINARy:ABORT`

:FILE:SAVE:{ASCIi|BINARy|FLOat|MEASure|SETup|SNAP}[:EXECute]

Function Saves the various types of data. This is an overlap command.

Syntax `:FILE:SAVE:{ASCIi|BINARy|FLOat|`
`MEASure|SETup|SNAP}[:EXECute]`

Example (The following example is for the waveform data.)
`:FILE:SAVE:BINARy:EXECUTE`

:FILE:SAVE:{ASCIi|BINARy|FLOat}:HISTORy

Function Sets whether to save all the waveform data or a selected waveform or queries the current setting.

Syntax `:FILE:SAVE:{ASCIi|BINARy|FLOat}:`
`HISTORy {ONE|ALL}`
`:FILE:SAVE:{ASCIi|BINARy|FLOat}:`
`HISTORy?`

Example `:FILE:SAVE:BINARy:HISTORy ALL`
`:FILE:SAVE:BINARy:HISTORy? ->`
`:FILE:SAVE:BINARy:HISTORy ALL`

:FILE:SAVE:{ASCIi|BINARy|FLOat}:RANGe

Function Sets the range of data to be saved or queries the current setting.

Syntax `:FILE:SAVE:{ASCIi|BINARy|FLOat}:`
`RANGe {MAIN|Z1|Z2|Z1_Z2}`
`:FILE:SAVE:{ASCIi|BINARy|FLOat}:`
`RANGe?`

Example `:FILE:SAVE:BINARy:RANGe MAIN`
`:FILE:SAVE:BINARy:RANGe? ->`
`:FILE:SAVE:BINARy:RANGe MAIN`

:FILE:SAVE:{ASCIi|BINARy|FLOat}:TRACe

Function Sets the waveform to be saved or queries the current setting.

Syntax `:FILE:SAVE:{ASCIi|BINARy|FLOat}:`
`TRACe {ALL|<NRF>|MATH<x>}`
`:FILE:SAVE:{ASCIi|BINARy|FLOat}:`
`TRACe?`
`<NRF>=1 to 4 (1 to 2 on the DL1720E)`
`<x>=1 or 2 (1 on the DL1720E)`

Example `:FILE:SAVE:ASCIi:TRACe 1`
`:FILE:SAVE:ASCIi:TRACe? ->`
`:FILE:SAVE:ASCIi:TRACe 1`

:FILE:SAVE:BINARy:COMPRESSION

Function Sets P-P compression for saving the waveform data or queries the current setting.

Syntax `:FILE:SAVE:BINARy:COMPRESSION`
`{<Boolean>}`
`:FILE:SAVE:BINARy:COMPRESSION?`

Example `:FILE:SAVE:BINARy:COMPRESSION ON`
`:FILE:SAVE:BINARy:COMPRESSION? ->`
`:FILE:SAVE:BINARy:COMPRESSION 1`

Description

- The range of data that is saved is the Main screen.
- Only binary data can be compressed.

:FILE:SAVE:COMMENT

Function Sets comments or queries the current setting.

Syntax `:FILE:SAVE:COMMENT`
`<Character string>`
`:FILE:SAVE:COMMENT?`
`<Character string>=Up to 25 characters`

Example `:FILE:SAVE:`
`COMMENT "THIS IS TEST. "`
`:FILE:SAVE:COMMENT? -> :FILE:SAVE:`
`COMMENT "THIS IS TEST. "`

Description Only the characters and symbols on the keyboard that appear on the instrument's screen can be used.
The "Ω" and "μ" symbols are represented by ASCII codes "1EH" and "1FH," respectively.

:FILE:SAVE:NAME

Function Sets the name of the data file to be saved or queries the current setting.

Syntax :FILE:SAVE:NAME <Filename>
:FILE:SAVE:NAME?

Example :FILE:SAVE:NAME "CASE1"
:FILE:SAVE:NAME? ->
:FILE:SAVE:NAME "CASE1"

:FILE:UNLoad?

Function Queries all settings related to clearing the loaded data.

Syntax :FILE:UNLoad?

Example :FILE:UNLOAD? -> :FILE:UNLOAD:
BINARY:TRACE 1;SNAP:PLANE 1

:FILE:UNLoad:{BINary|SNAP}?

Function Queries all setting related to the unloading of various data that has been loaded.

Syntax :FILE:UNLoad:{BINary|SNAP}?

Example :FILE:UNLOAD:BINARY? ->
:FILE:UNLOAD:BINARY:TRACE 1

:FILE:UNLoad:{BINary|SNAP}[:EXECute]

Function Executes the unloading of the various data that has been loaded. This is an overlap command.

Syntax :FILE:UNLoad:{BINary|SNAP}
[:EXECute]

Example :FILE:UNLOAD:BINARY:EXECUTE

:FILE:UNLoad:BINary:TRACe

Function Of the data that has been loaded, sets the waveform to be unloaded or queries the current setting.

Syntax :FILE:UNLoad:BINary:TRACe
{ALL|<NRf>|MATH<x>}
:FILE:UNLoad:BINary:TRACe?
<NRf>=1 to 4 (1 to 2 on the DL1720E)
<x>=1 or 2 (1 on the DL1720E)

Example :FILE:UNLOAD:BINARY:TRACE 1
:FILE:UNLOAD:BINARY:TRACE? ->
:FILE:UNLOAD:BINARY:TRACE 1

:FILE:UNLoad:SNAP:PLANE

Function Of the snapshot waveform that has been loaded, sets the plane number to be unloaded or queries the current setting.

Syntax :FILE:UNLoad:SNAP:PLANE {ALL|<NRf>}
:FILE:UNLoad:SNAP:PLANE?
<NRf>=1 to 4

Example :FILE:UNLOAD:SNAP:PLANE ALL
:FILE:UNLOAD:SNAP:PLANE? ->
:FILE:UNLOAD:SNAP:PLANE ALL

5.11 GONogo Group

5.11 GONogo Group

The commands in the GONogo group deal with the GO/NO-GO determination. These commands can be used to make the same settings and inquiries as when GO/NO-GO on the front panel is pressed.

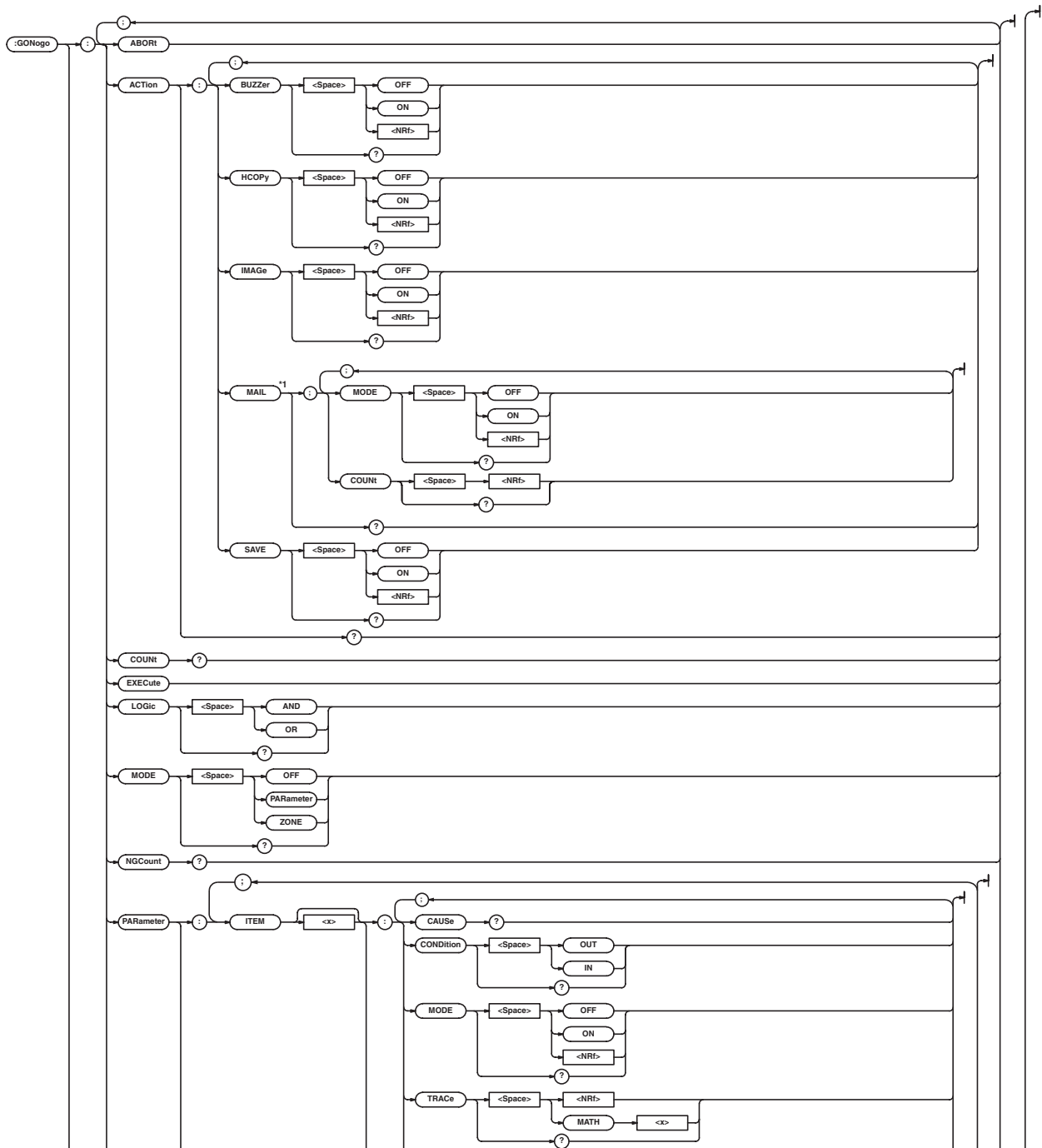

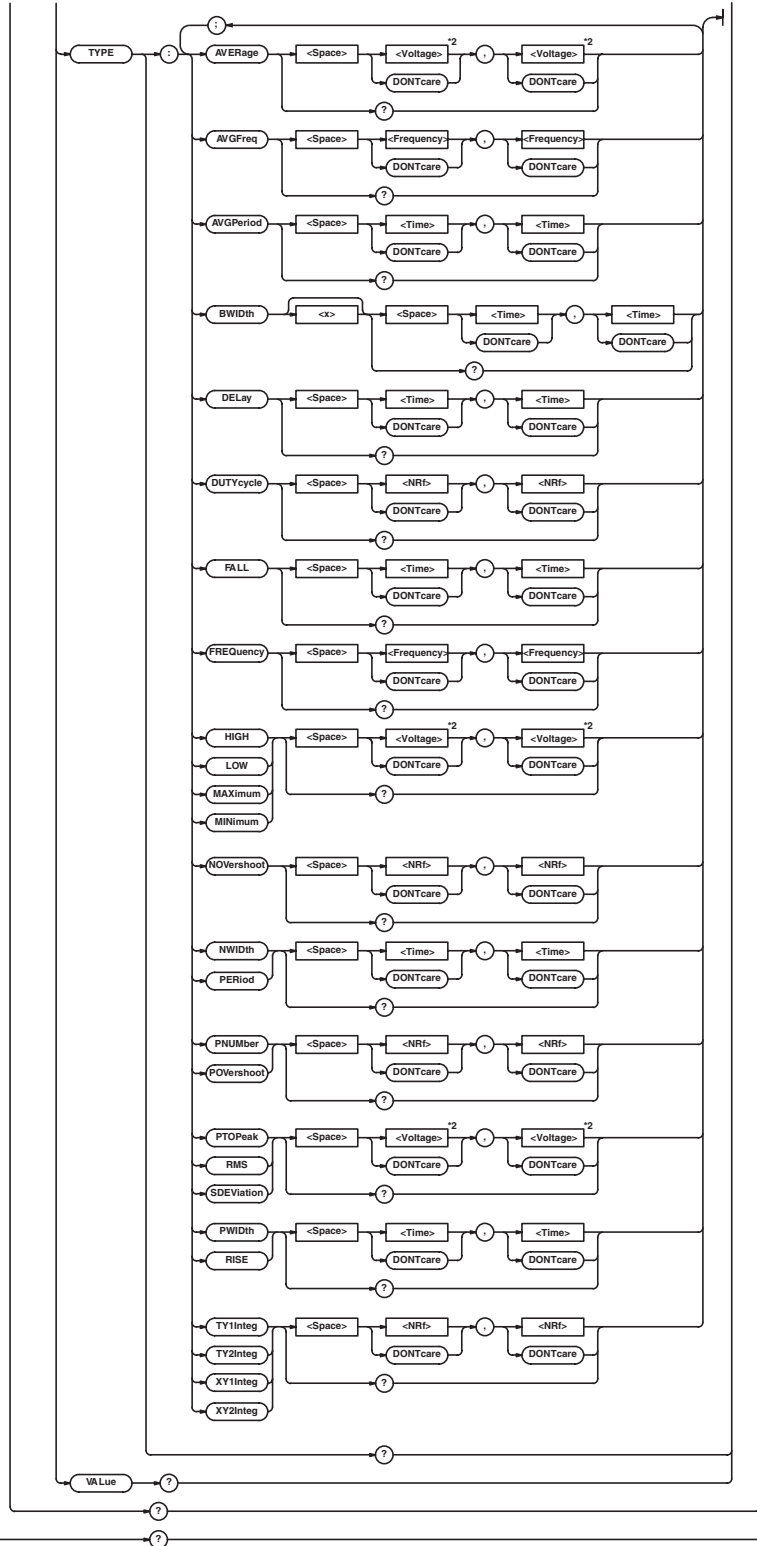

5.11 GONogo Group

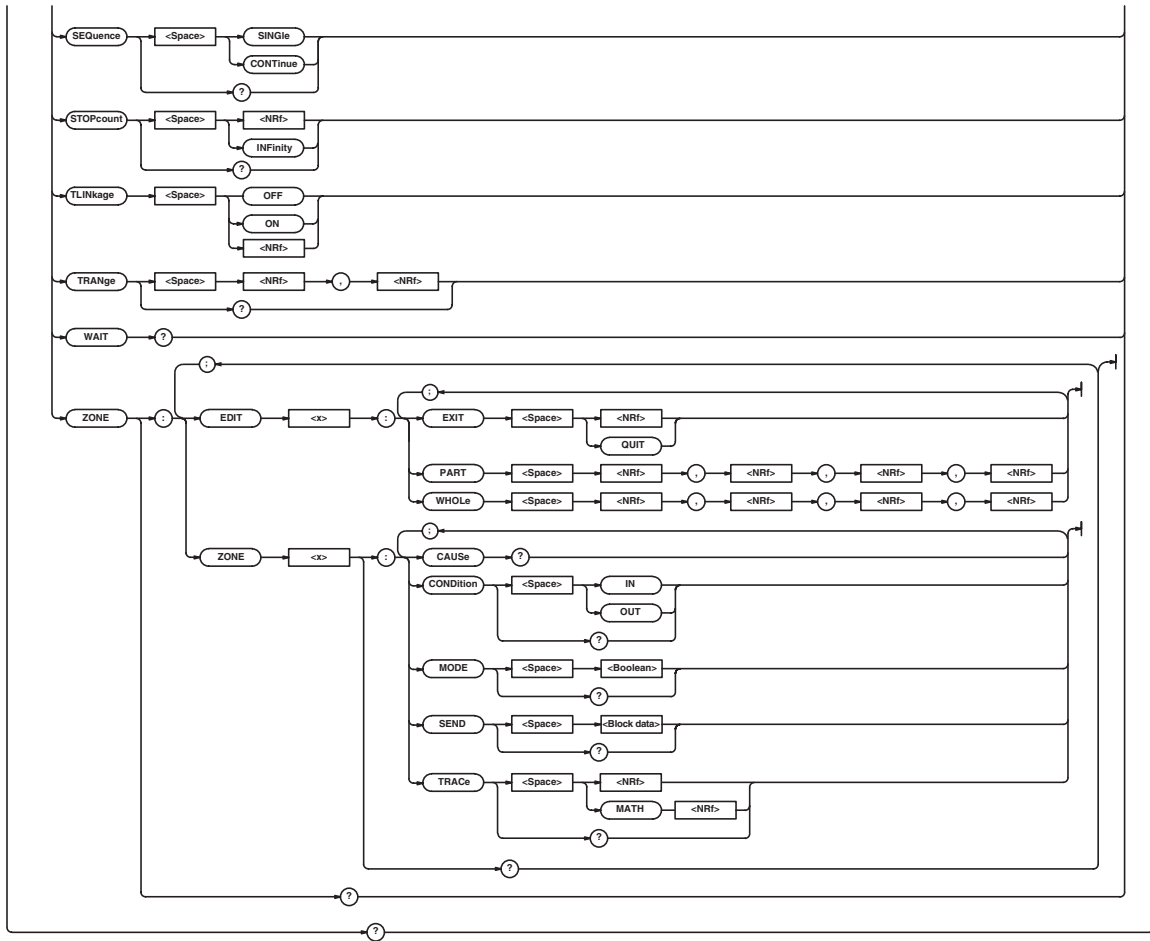

- *1 Can be used when the Ethernet interface (option) is installed.
- *2 When the target channel is set to the current probe, becomes <Current>.

:GONogo?

Function Queries all settings related to GO/NO-GO determination.

Syntax :GONogo?

Example :GONOGO? -> :GONOGO:MODE OFF;
PARAMETER:ITEM1:MODE 0;TRACE 1;
TYPE:MAXIMUM DONTCARE,DONTCARE;;
GONOGO:PARAMETER:ITEM1:
CONDITION OUT;;GONOGO:PARAMETER:
ITEM2:MODE 0;TRACE 1;TYPE:
MINIMUM DONTCARE,DONTCARE;;GONOGO:
PARAMETER:ITEM2:CONDITION OUT;;
GONOGO:PARAMETER:ITEM3:MODE 0;
TRACE 1;TYPE:RMSDONTCARE,DONTCARE;;
GONOGO:PARAMETER:ITEM3:
CONDITION OUT;;GONOGO:PARAMETER:
ITEM4:MODE 0;TRACE 1;TYPE:
AVERAGE DONTCARE,DONTCARE;;
GONOGO:PARAMETER:ITEM4:
CONDITION OUT;;GONOGO:ZONE:ZONE1:
TRACE 1;MODE 0;CONDITION OUT;;
GONOGO:ZONE:ZONE2:TRACE 2;MODE 0;
CONDITION OUT;;GONOGO:ZONE:ZONE3:
TRACE 3;MODE 0;CONDITION OUT;;
GONOGO:ZONE:ZONE4:TRACE 4;MODE 0;
CONDITION OUT;;GONOGO:ZONE:ZONE5:
TRACE MATH1;MODE 0;CONDITION OUT;;
GONOGO:ZONE:ZONE6:TRACE MATH2;
MODE 0;CONDITION OUT;;GONOGO:
LOGIC AND;SEQUENCE SINGLE;
STOPCOUNT INFINITE;ACTION:BUZZER 0;
SAVE 0;IMAGE 0;HCOPY 0;;GONOGO:
TLINKAGE 0;
TRANGE -5.0000000,5.0000000

:GONogo:ABORT

Function Aborts GO/NO-GO determination.

Syntax :GONogo:ABORT

Example :GONOGO:ABORT

:GONogo:ACTion?

Function Queries all settings related to the action to be performed when the result of the determination is NO-GO and also the determination criteria.

Syntax :GONogo:ACTion?

Example :GONOGO:ACTion? ->
:GONOGO:ACTION:BUZZER 0;IMAGE 0;
HCOPY 0;SAVE 0

:GONogo:ACTion:BUZZer

Function Sets whether or not to sound an alarm when the determination is NO-GO or queries the current setting.

Syntax :GONogo:ACTion:BUZZer {<Boolean>}
:GONogo:ACTion:BUZZer?

Example :GONOGO:ACTION:BUZZER OFF
:GONOGO:ACTION:BUZZER? ->
:GONOGO:ACTION:BUZZER 0

:GONogo:ACTion:HCOPY (Hard COPY)

Function Sets whether to print the screen image to the built-in printer (optional) during NO-GO determination or queries the current setting.

Syntax :GONogo:ACTion:HCOPY {<Boolean>}
:GONogo:ACTion:HCOPY?

Example :GONOGO:ACTION:HCOPY OFF
:GONOGO:ACTION:HCOPY? ->
:GONOGO:ACTION:HCOPY 0

:GONogo:ACTion:IMAGE

Function Sets whether or not to save the screen image to the external storage medium for NO-GO determination or queries the current setting.

Syntax :GONogo:ACTion:IMAGE {<Boolean>}
:GONogo:ACTion:IMAGE?

Example :GONOGO:ACTION:IMAGE OFF
:GONOGO:ACTION:IMAGE? ->
:GONOGO:ACTION:IMAGE 0

:GONogo:ACTion:MAIL?

Function Queries the all settings for an e-mail to be sent when the determination is NO-GO.

Syntax :GONogo:ACTion:MAIL?

Example :GONOGO:ACTION:MAIL? ->
:GONOGO:ACTION:MAIL:MODE 1;
COUNT 100

Description Can be used when the Ethernet interface (option) is installed.

:GONogo:ACTion:MAIL:COUNT

Function Sets/queries the maximum number of e-mail to be sent when the determination is NO-GO.

Syntax :GONogo:ACTion:MAIL:COUNT {<NRf>}
:GONogo:ACTion:MAIL:COUNT?
<NRf>=1 to 1000

Example :GONOGO:ACTION:MAIL:COUNT 100
:GONOGO:ACTION:MAIL:COUNT? ->
:GONOGO:ACTION:MAIL:COUNT 100

Description Can be used when the Ethernet interface (option) is installed.

:GONogo:ACTion:MAIL:MODE

Function Sets/queries whether an e-mail report is sent when the determination is NO-GO.

Syntax :GONogo:ACTion:MAIL:MODE
{<Boolean>}
:GONogo:ACTion:MAIL:MODE?

Example :GONOGO:ACTION:MAIL:MODE OFF
:GONOGO:ACTION:MAIL:MODE? ->
:GONOGO:ACTION:MAIL:MODE 0

Description Can be used when the Ethernet interface (option) is installed.

:GONogo:ACTion:SAVE

Function Sets whether or not to save the NO-GO result to the storage medium or queries the current setting.

Syntax :GONogo:ACTion:SAVE {<Boolean>}
:GONogo:ACTion:SAVE?

Example :GONOGO:ACTION:SAVE OFF
:GONOGO:ACTION:SAVE? ->
:GONOGO:ACTION:SAVE 0

Description Use the ":FILE:DIRECTORY:DRIVE" command to set or query the storage medium type.

5.11 GONogo Group

:GONogo:COUNT?

Function Queries the actual number of times the GO/NO-GO determination has been performed.

Syntax :GONogo:COUNT?

Example :GONOGO:COUNT? -> :GONOGO:COUNT 100

:GONogo:EXECute

Function Executes GO/NO-GO determination. This is an overlap command.

Syntax :GONogo:EXECute

Example :GONOGO:EXECUTE

:GONogo:LOGic

Function Sets the GO/NO-GO determination logic or queries the current setting.

Syntax :GONogo:LOGic {AND|OR}

Example :GONOGO:LOGIC AND
:GONOGO:LOGIC? -> :GONOGO:LOGIC AND

:GONogo:MODE

Function Sets the GO/NO-GO determination type or queries the current setting.

Syntax :GONogo:MODE {OFF|PARAMeter|ZONE}

Example :GONOGO:MODE PARAMETER
:GONOGO:MODE? ->
:GONOGO:MODE PARAMETER

:GONogo:NGCount?

Function Queries the number of NO-GO results.

Syntax :GONogo:NGCount?

Example :GONOGO:NGCOUNT? ->
:GONOGO:NGCOUNT 5

:GONogo:PARAMeter?

Function Queries all settings related to the waveform parameter determination.

Syntax :GONogo:PARAMeter?

Example :GONOGO:PARAMETER? ->
:GONOGO:PARAMETER:ITEM1:MODE 0;
TRACE 1;TYPE:MAXIMUM 1.0000E+00,
-1.0000E+00;;GONOGO:PARAMETER:
ITEM1:CONDITION OUT;;GONOGO:
PARAMETER:ITEM2:MODE 0;TRACE 1;
TYPE:MINIMUM 1.0000E+00,
-1.0000E+00;;GONOGO:PARAMETER:
ITEM2:CONDITION OUT;;GONOGO:
PARAMETER:ITEM3:MODE 0;TRACE 1;
TYPE:RMS 1.0000E+00,-1.0000E+00;;
GONOGO:PARAMETER:ITEM3:
CONDITION OUT;;GONOGO:PARAMETER:
ITEM4:MODE 0;TRACE 1;TYPE:
AVERAGE 1.0000E+00,-1.0000E+00;;
GONOGO:PARAMETER:ITEM4:
CONDITION OUT

:GONogo:PARAMeter:ITEM<x>?

Function Queries all settings related to waveform parameters.

Syntax :GONogo:PARAMeter:ITEM<x>?

Example :GONOGO:PARAMETER:ITEM1? ->
:GONOGO:PARAMETER:ITEM1:MODE 0;
TRACE 1;TYPE:MAXIMUM 1.0000E+00,
-1.0000E+00;;GONOGO:PARAMETER:
ITEM1:CONDITION OUT

:GONogo:PARAMeter:ITEM<x>:CAUSE?

Function Queries whether or not the waveform parameter is the cause of the NO-GO result.

Syntax :GONogo:PARAMeter:ITEM<x>:CAUSE?

Example :GONOGO:PARAMETER:ITEM1:CAUSE? ->
:GONOGO:PARAMETER:ITEM1:CAUSE 1

Description The query returns a "1" if the parameter is the cause of the NO-GO result or a "0" if it is not.

:GONogo:PARAMeter:ITEM<x>:CONDition

Function Sets the criteria of the waveform parameters on which GO/NO-GO determination is to be performed or queries the current setting.

Syntax :GONogo:PARAMeter:ITEM<x>:CONDition {IN|OUT}

Example :GONOGO:PARAMETER:ITEM1:
CONDITION?
<x>=1 to 4
:GONOGO:PARAMETER:ITEM1:
CONDITION OUT
:GONOGO:PARAMETER:ITEM1:
CONDITION? ->
:GONOGO:PARAMETER:ITEM1:
CONDITION OUT

:GONogo:PARAMeter:ITEM<x>:MODE

Function Turns ON/OFF the waveform parameters on which GO/NO-GO determination is to be performed or queries the current setting.

Syntax :GONogo:PARAMeter:ITEM<x>:MODE {<Boolean>}

Example :GONOGO:PARAMETER:ITEM<x>:MODE OFF
:GONOGO:PARAMETER:ITEM<x>:MODE? ->
:GONOGO:PARAMETER:ITEM<x>:MODE 0

:GONogo:PARAMeter:ITEM<x>:TRACe

Function Sets the target waveform of the waveform parameters on which GO/NO-GO determination is to be performed or queries the current setting.

Syntax :GONogo:PARAMeter:ITEM<x>:TRACe {<NRf>|MATH<x>}

Example :GONOGO:PARAMETER:ITEM1:TRACE 1
:GONOGO:PARAMETER:ITEM1:TRACE? ->
:GONOGO:PARAMETER:ITEM1:TRACE 1

:GONogo:PARAMeter:ITEM<x>:TYPE?

Function Queries the automated measurement parameters and the upper and lower limits of the waveform parameters on which GO/NO-GO determination is to be performed.

Syntax :GONogo:PARAMeter:ITEM<x>:TYPE?

Example :GONOGO:PARAMETER:ITEM1:TYPE? ->
:GONOGO:PARAMETER:ITEM1:TYPE:
PTOPEAK 2.000E+00,1.000E+00

**:GONogo:PARAMeter:ITEM<x>:TYPE:
<Parameter>**

Function Sets the upper and lower limits of the automated measurement parameter of the specified waveform parameter on which GO/NO-GO determination is to be performed or queries the current setting.

Syntax :GONogo:PARAMeter:ITEM<x>:TYPE:
<Parameter>
{<{Voltage|DONTcare}>,<{Voltage|DONTcare}>|<{Current|DONTcare}>,<{Current|DONTcare}>|<{Time|DONTcare}>,<{Time|DONTcare}>|<{Frequency|DONTcare}>,<{Frequency|DONTcare}>|<{{<Nrf>}|DONTcare}>,<{{<Nrf>}|DONTcare}>}
<Parameter>?
<Parameter>={AVERAGE|AVGFreq|AVGPeriod|BWIDTh1|BWIDTh2|DElay|DUTYcycle|FALL|FREQuency|HIGH|LOW|MAXimum|MINimum|NOVershoot|NWIDTH|PERiod|PNUMBER|POVershoot|PTOPeak|PWIDTh|RISE|RMS|SDEviation|TY1Integ|TY2Integ|XY1Integ|XY2Integ}
<x>=1 to 4
<Voltage>,<Time>,<Frequency>,<Nrf>=See the User's Manual.

Example :GONOGO:PARAMETER:ITEM1:TYPE:
AVERAGE 100mV,-100mV
:GONOGO:PARAMETER:ITEM1:TYPE:
AVERAGE? ->
:GONOGO:PARAMETER:ITEM1:
TYPE:AVERAGE 100.0E-03,-100.0E-03

Description

- Queries are only allowed on the parameters that have been set using this command.
- When a current probe is used, this command sets or queries the <Current> value.

:GONogo:PARAMeter:ITEM<x>:VALue?

Function Queries the automated measurement values of the waveform parameters on which GO/NO-GO determination is to be performed.

Syntax :GONogo:PARAMeter:ITEM<x>:VALue?
<x>=1 to 4

Example :GONOGO:PARAMETER:ITEM1:VALUE? ->
:GONOGO:PARAMETER:ITEM1:
VALUE 1.98E-03

Description If the measurement is not possible (the mode is OFF, for example), "NAN(Not A Number)" is returned.

:GONogo:SEQuence

Function Selects single or continuous action or queries the current setting.

Syntax :GONogo:SEQuence
{CONTInuous|SINGLE}
:GONogo:SEQuence?

Example :GONOGO:SEQUENCE SINGLE
:GONOGO:SEQUENCE? ->
:GONOGO:SEQUENCE SINGLE

:GONogo:STOPcount

Function Sets the number of waveform acquisitions on which to perform GO/NO-GO determination or queries the current setting.

Syntax :GONogo:STOPcount {<Nrf>|INFinity}
:GONogo:STOPcount?
<Nrf>=1 to 65536

Example :GONOGO:PARAMETER:STOPCOUNT 10
:GONOGO:PARAMETER:STOPCOUNT? ->
:GONOGO:STOPCOUNT 10

:GONogo:TLinkage

Function Turns ON/OFF the linked movement of the determination range cursor of the GO/NO-GO determination.

Syntax :GONogo:TLinkage {<Boolean>}
:GONogo:TLinkage?

Example :GONOGO:TLinkage ON
:GONOGO:TLinkage? ->
:GONOGO:TLinkage 1

:GONogo:TRAnge

Function Sets the range over which to perform GO/NO-GO determination or queries the current setting.

Syntax :GONogo:TRAnge {<Nrf>},{<Nrf>}
:GONogo:TRAnge?
<Nrf>=-5.00 to 5.00 (10 div/displayed record length steps)

Example :GONOGO:TRANGE -5.00,5.00
:GONOGO:TRANGE? ->
:GONOGO:TRANGE -5.00,5.00

:GONogo:WAIT?

Function Waits for the GO/NO-GO determination to complete with a timeout.

Syntax :GONogo:WAIT? {<Nrf>}
<Nrf>=1 to 864000 (in units of 100 ms)

Example (Set the timeout to 5 s.)
:GONOGO:WAIT? 50 -> :GONOGO:WAIT 0

Description Returns "1" if it times out, "02 if it completes before timing out.

:GONogo:ZONE?

Function Queries all settings related to GO/NO-GO determination using zones.

Syntax :GONogo:ZONE?

Example :GONOGO:ZONE? -> :GONOGO:ZONE:
ZONE1:TRACE 1;MODE 0;
CONDITION OUT;;GONOGO:ZONE:ZONE2:
TRACE 2;MODE 0;CONDITION OUT;;
GONOGO:ZONE:ZONE3:TRACE 3;MODE 0;
CONDITION OUT;;GONOGO:ZONE:ZONE4:
TRACE 4;MODE 0;CONDITION OUT;;
GONOGO:ZONE:ZONE5:TRACE MATH1;
MODE 0;CONDITION OUT;;GONOGO:ZONE:
ZONE6:TRACE MATH2;MODE 0;
CONDITION OUT

5.11 GONogo Group

:GONogo:ZONE:EDIT<x>:EXIT

Function Exits from the edit menu of the zone for the GO/NO-GO determination using zones.

Syntax :GONogo:ZONE:EDIT<x>:EXIT
{<Nrf>|QUIT}
<X>=1 to 12 (1 to 4 are traces; 5 and 6 is MATH1 and 2; 7 to 12 are determination zones 1 to 6.)
(On the DL1720E, <X>=1, 2, 5, 7, 8, or 9 (1 to 2 are traces; 5 is MATH1; 7 to 9 are determination zones 1 to 3.))
<Nrf>=1 to 6 (destination zone No. for saving the zone being edited)
On the DL1720E, <Nrf>=1 to 3.

Example :GONOGO:ZONE:EDIT1:EXIT 1
Description This command must be issued to keep the zones specified using “:GONogo:ZONE:EDIT<x>:{PART|WHOLE}.”
An error occurs if this command is issued when the zone is not being edited.

:GONogo:ZONE:EDIT<x>:PART

Function Sets the partial edit of the zone for the GO/NO-GO determination using zones.

Syntax :GONogo:ZONE:EDIT<x>:PART
{<Nrf>,<Nrf>,<Nrf>,<Nrf>}
<X>=1 to 12 (1 to 4 are traces; 5 and 6 is MATH1 and 2; 7 to 12 are determination zones 1 to 6.)
(On the DL1720E, <X>=1, 2, 5, 7, 8, or 9 (1 to 2 are traces; 5 is MATH1; 7 to 9 are determination zones 1 to 3.))
<Nrf>=-5.00 to 5.00 (div, 0.01 div steps: T1 and T2 cursors)
-8.00 to 8.00 (div, 0.01 steps: up and down)
(In the order T1, T2, ↑, and ↓)

Example :GONOGO:ZONE:EDIT1:
PART -2.50,2.50,1.00,1.00
Description When you finish editing, you must exit the edit mode using the
“:GONogo:ZONE:EDIT<x>:EXIT” command to keep the new zone.

:GONogo:ZONE:EDIT<x>:WHOLE

Function Edits the zone for the GO/NO-GO determination using zones.

Syntax :GONogo:ZONE:EDIT<x>:WHOLE
{<Nrf>,<Nrf>,<Nrf>,<Nrf>}
<X>=1 to 12 (1 to 4 are traces; 5 and 6 is MATH1 and 2; 7 to 12 are determination zones 1 to 6.)
(On the DL1720E, <X>=1, 2, 5, 7, 8, or 9 (1 to 2 are traces; 5 is MATH1; 7 to 9 are determination zones 1 to 3.))
<Nrf>=0 to 5.00 (div, 0.01 steps: left and right)
0 to 8.00 (div, 0.01 steps: up and down)
(In the order ←, →, ↑, and ↓)

Example :GONOGO:ZONE:EDIT1:
WHOLE -2.50,2.50,1.00,1.00
Description When you finish editing, you must exit the edit mode using the
“:GONogo:ZONE:EDIT<x>:EXIT” command to keep the new zone.

:GONogo:ZONE:ZONE<x>?

Function Queries all settings related to GO/NO-GO determination using zones of the specified zone.

Syntax :GONogo:ZONE:ZONE<x>?
<x>=1 to 6 (1 to 3 on the DL1720E)
Example :GONOGO:ZONE:ZONE1? ->
:GONOGO:ZONE:ZONE1:TRACE 1;MODE 0;
CONDITION OUT

:GONogo:ZONE:ZONE<x>:CAUSE?

Function Queries whether or not the specified zone for the GO/NO-GO determination using zones is the cause of the NO-GO result.

Syntax :GONogo:ZONE:ZONE<x>:CAUSE?
<x>=1 to 6 (1 to 3 on the DL1720E)
Example :GONOGO:ZONE:ZONE1:CAUSE? ->
:GONOGO:ZONE:ZONE1:CAUSE 1
Description The query returns a “1” if the zone is the cause of the NO-GO result or a “0” if it is not.

:GONogo:ZONE:ZONE<x>:CONDition

Function Sets the criteria for the zone for the GO/NO-GO determination using zones or queries the current setting.

Syntax :GONogo:ZONE:ZONE<x>:CONDition
{IN|OUT}
:GONogo:ZONE:ZONE<x>:CONDition?
<x>=1 to 6 (1 to 3 on the DL1720E)
Example :GONOGO:ZONE:ZONE1:CONDition IN
:GONOGO:ZONE:ZONE1:CONDition? ->
:GONOGO:ZONE:ZONE1:CONDition IN

:GONogo:ZONE:ZONE<x>:MODE

Function Turns ON/OFF the determination of the zone or queries the current setting.

Syntax :GONogo:ZONE:ZONE<x>:MODE
{<Boolean>}
:GONogo:ZONE:ZONE<x>:MODE?
<x>=1 to 6 (1 to 3 on the DL1720E)
Example :GONOGO:ZONE:ZONE1:MODE ON
:GONOGO:ZONE:ZONE1:MODE? ->
:GONOGO:ZONE:ZONE1:MODE 1

:GONogo:ZONE:ZONE<x>:SEND

Function	Sets the zone data specified for the GO/NO-GO determination zone or queries the current setting.
Syntax	:GONogo:ZONE:ZONE<x>:SEND #6004028(data string) :GONnogo:ZONE:ZONE<x>:SEND? <x>=1 to 6 (1 to 3 on the DL1720E)
Example	:GONOGO:ZONE:ZONE1:SEND #6004028(data string) :GONOGO:ZONE:ZONE1:SEND? -> :GONOGO:ZONE:ZONE1:SEND #6004028(data string)
Description	<ul style="list-style-type: none"> The (data string) consists of zone data of length 4028 bytes. Zone data consist of 8-bit data (0 to 255). This data string may contain ASCII codes "0AH" or "00H" that stand for "NL." Hence, care must be taken when programming the controller. This command is used to save the zone data to the PC and set the data as zone data on the instrument. When this command is used to set the zone data to the instrument to perform the determination, issue the ":GONogo:ZONE:ZONE<x>:MODE ON" command afterwards.

:GONogo:ZONE:ZONE<x>:TRACe

Function	Sets the target trace of the zone for GO/NO-GO determination using zones or queries the current setting.
Syntax	:GONogo:ZONE:ZONE<x>:TRACe {<NRf> MATH<y>} :GONogo:ZONE:ZONE<x>:TRACe? <NRf>=1 to 4 (1 to 2 on the DL1720E) <x>=1 to 6 (1 to 3 on the DL1720E) <y>=1 or 2 (1 on the DL1720E)
Example	:GONOGO:ZONE:ZONE1:TRACe 1 :GONOGO:ZONE:ZONE1:TRACe -> :GONOGO:ZONE:ZONE1:TRACe 1

5.12 HCOpy Group

The commands in the HCOpy group are used to make settings and queries about screen image data print, for example, output to the optional built-in printer. You can make the same settings that you can make by pressing SHIFT, then pressing COPY.

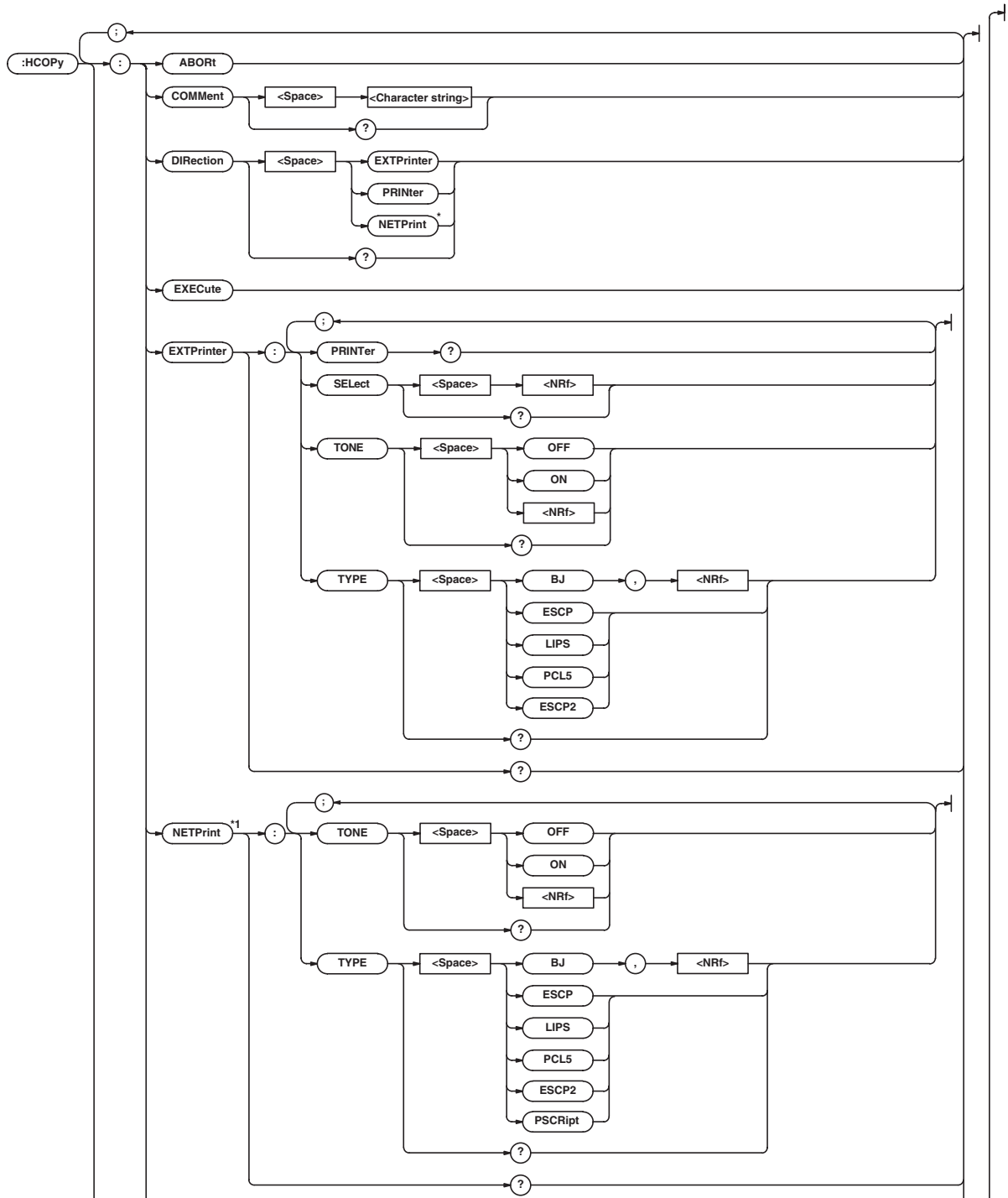

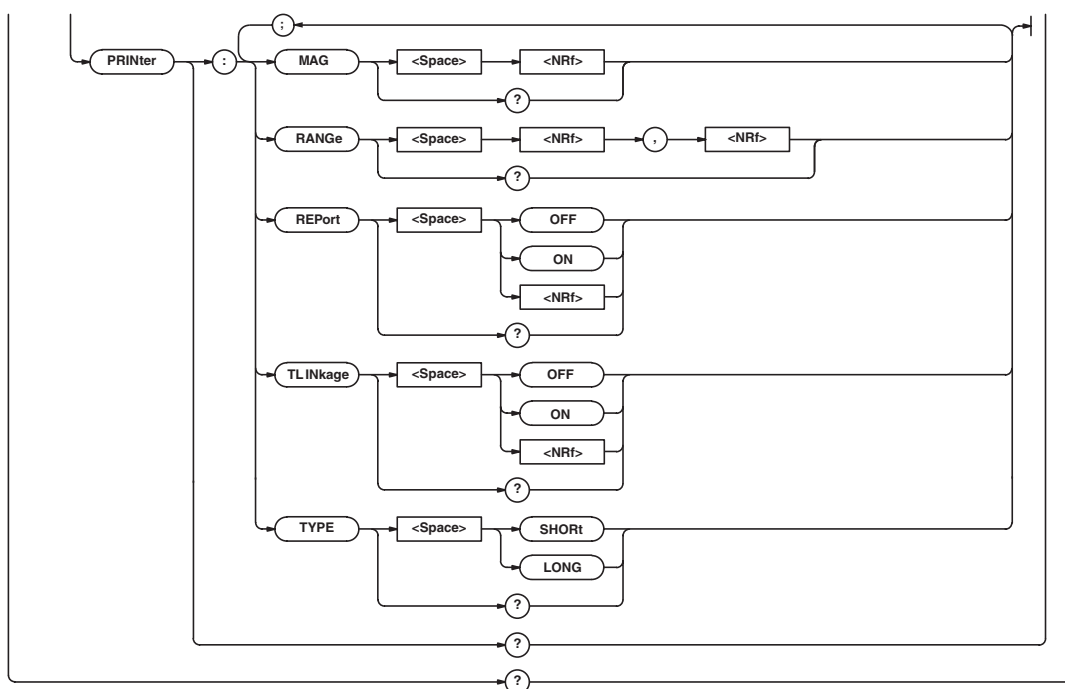

* Can be used when the Ethernet interface (option) is installed.

:HCOpy? (Hard COPY)

Function Queries all settings relating to print of screen image data.

Syntax :HCOpy?

Example :HCOpy? ->

```
:HCOpy:DIRECTION PRINTER;PRINter:
TYPE SHORT;REPORT 0;MAG 2.0;
TLINKAGE 0;RANGE -5.0000000,
5.0000000;:HCOpy:EXTPRINter:
TYPE ESCP;TONE 0;SELECT NAN;:HCOpy:
NETPRINter:TYPE ESCP;TONE 0;:HCOpy:
COMMENT ""
```

:HCOpy:ABORT

Function Aborts print operation and paper feed.

Syntax :HCOpy:ABORT

Example :HCOpy:ABORT

:HCOpy:COMMeNt

Function Sets/queries the comment to be displayed at the screen.

Syntax :HCOpy:COMMeNt <Character string>
:HCOpy:COMMeNt?

<Character string>=Within 20 characters
Example :HCOpy:COMMeNt "THIS IS TEST."
:HCOpy:COMMeNt? ->
:HCOpy:COMMeNt "THIS IS TEST."

:HCOpy:DIRectioN

Function Sets the printer or queries the current setting.

Syntax :HCOpy:DIRectioN
{EXTPRINter|PRINter|NETPRINter}
:HCOpy:DIRectioN?

Example :HCOpy:DIRectioN PRINter
:HCOpy:DIRectioN? ->
:HCOpy:DIRectioN PRINter

Description "NETPrint" can be used when the Ethernet interface (option) is installed.

:HCOpy:EXECute

Function Executes the print operation. This is an overlap command.

Syntax :HCOpy:EXECute

Example :HCOpy:EXECute

:HCOpy:EXTPRINter?

Function Queries all settings related to printing when using an external printer.

Syntax :HCOpy:EXTPRINter?

Example :HCOpy:EXTPRINter? -> :HCOpy:
EXTPRINter:TYPE BJ,360;TONE 1;
SELECT NAN

:HCOpy:EXTPRINter:PRINter?

Function Queries the addresses of all the printers that are currently connected.

Syntax :HCOpy:EXTPRINter:PRINter?

Example (The following is an example when printers are connected to address 2 and 3.)
:HCOpy:EXTPRINter:PRINter? ->
:HCOpy:EXTPRINter:PRINter 2,3

:HCOpy:EXTPRINter:SElect

Function Sets the printer address or queries the current setting.

Syntax :HCOpy:EXTPRINter:SElect {<NRF>}
:HCOpy:EXTPRINter:SElect?

<NRF>=1 to 127
Example :HCOpy:EXTPRINter:SElect 3
:HCOpy:EXTPRINter:SElect? ->
:HCOpy:EXTPRINter:SElect 3

Description If you specify an address at which no printer is connected, an error occurs. In this case, "NAN (Not A Number)" is returned.

5.12 HCOpy Group

:HCOpy:EXTPrinter:TONE

Function Sets the half tone when printing using an external printer or queries the current setting.

Syntax :HCOpy:EXTPrinter:TONE {<Boolean>}
:HCOpy:EXTPrinter:TONE?

Example :HCOpy:EXTPRINTER ON
:HCOpy:EXTPRINTER? ->
:HCOpy:EXTPRINTER TONE 1

:HCOpy:EXTPrinter:TYPE

Function Sets the type of output commands to send to the external printer or queries the current setting.

Syntax :HCOpy:EXTPrinter:TYPE
{BJ,<Nrf>|ESCP|LIPS|PCL5|ESCP2}
:HCOpy:EXTPrinter:TYPE?
<Nrf>=180, 300, 360 or 600 (dpi)

Example :HCOpy:EXTPRINTER:TYPE BJ,360
:HCOpy:EXTPRINTER:TYPE? ->
:HCOpy:EXTPRINTER:TYPE BJ,360

Description <Nrf> is specified only when the type is set to "BJ."

:HCOpy:NETprint?

Function Queries all settings related to printing using a network printer.

Syntax :HCOpy:NETPrint?

Example :HCOpy:NETPRINT? -> :HCOpy:
NETPRINT:TYPE POSTSCRIPT;TONE 1

Description Can be used when the Ethernet interface (option) is installed.

:HCOpy:NETprint:TONE

Function Sets the half tone when printing using a network printer or queries the current setting.

Syntax :HCOpy:NETPrint:TONE {<Boolean>}
:HCOpy:NETPrint:TONE?

Example :HCOpy:NETPRINT:TONE ON
:HCOpy:NETPRINT:TONE? ->
:HCOpy:NETPRINT:TONE 1

Description Can be used when the Ethernet interface (option) is installed.

:HCOpy:NETprint:TYPE

Function Sets the printer description language sent to the network printer or the type of printer or queries the current setting.

Syntax :HCOpy:NETPrint:TYPE
{BJ,<Nrf>|ESCP|LIPS|PCL5|ESCP2|PSCRIPT}
:HCOpy:NETPrint:TYPE?
<Nrf>=180, 300, 360 or 600 (dpi)

Example :HCOpy:NETPRINT:TYPE PSCRIPT
:HCOpy:NETPRINT:TYPE? ->
:HCOpy:NETPRINT:TYPE PSCRIPT

Description <Nrf> is specified only when the type is set to "BJ." Can be used when the Ethernet interface (option) is installed.

:HCOpy:PRINter?

Function Queries all settings related to printing when using the built-in printer.

Syntax :HCOpy:PRINter?

Example :HCOpy:PRINTER? ->
:HCOpy:PRINTER:TYPE SHORT;REPORT 0;
TLINKAGE 0;RANGE -5.00,5.00;MAG 2

:HCOpy:PRINter:MAG

Function Sets the magnification for long print or queries the current setting.

Syntax :HCOpy:PRINter:MAG {<Nrf>}
:HCOpy:PRINter:MAG?
<Nrf>=2 to 25000 (See the User's Manual.)

Example :HCOpy:PRINTER:MAG 1
:HCOpy:PRINTER:MAG? ->
:HCOpy:PRINTER:MAG 1

:HCOpy:PRINter:RANGE

Function Sets the print range for long print or queries the current setting.

Syntax :HCOpy:PRINter:RANGE
{<Nrf>},{<Nrf>}
:HCOpy:PRINter:RANGE?
<Nrf>=-5.00 to 5.00 (10 div/displayed record length steps)

Example :HCOpy:PRINTER:RANGE -2.50,2.50
:HCOpy:PRINTER:RANGE? ->
:HCOpy:PRINTER:RANGE -2.50,2.50

:HCOpy:PRINter:REPort

Function Sets whether to print additional information when printing to the built-in printer or queries the current setting.

Syntax :HCOpy:PRINter:REPort {<Boolean>}
:HCOpy:PRINter:REPort?

Example :HCOpy:PRINTER:REPORT ON
:HCOpy:PRINTER:REPORT? ->
:HCOpy:PRINTER:REPORT 1

:HCOpy:PRINter:TLINKage

Function Turns ON/OFF the linked movement of the print range cursors for long print using the built-in printer or queries the current setting.

Syntax :HCOpy:PRINter:TLINKage {<Boolean>}
:HCOpy:PRINter:TLINKage?

Example :HCOpy:PRINTER:TLINKAGE ON
:HCOpy:PRINTER:TLINKAGE ->
:HCOpy:PRINTER:TLINKAGE 1

:HCOpy:PRINter:TYPE

Function Sets short print or long print when printing to the built-in printer or queries the current setting.

Syntax :HCOpy:PRINter:TYPE {LONG|SHORT}
:HCOpy:PRINter:TYPE?

Example :HCOpy:PRINTER:TYPE SHORT
:HCOpy:PRINTER:TYPE? ->
:HCOpy:PRINTER:TYPE SHORT

5.13 HISTory Group

The commands in the HISTory group are used to make settings and queries about the history memory function. You can make the same settings that you can make using HISTORY on the front panel.

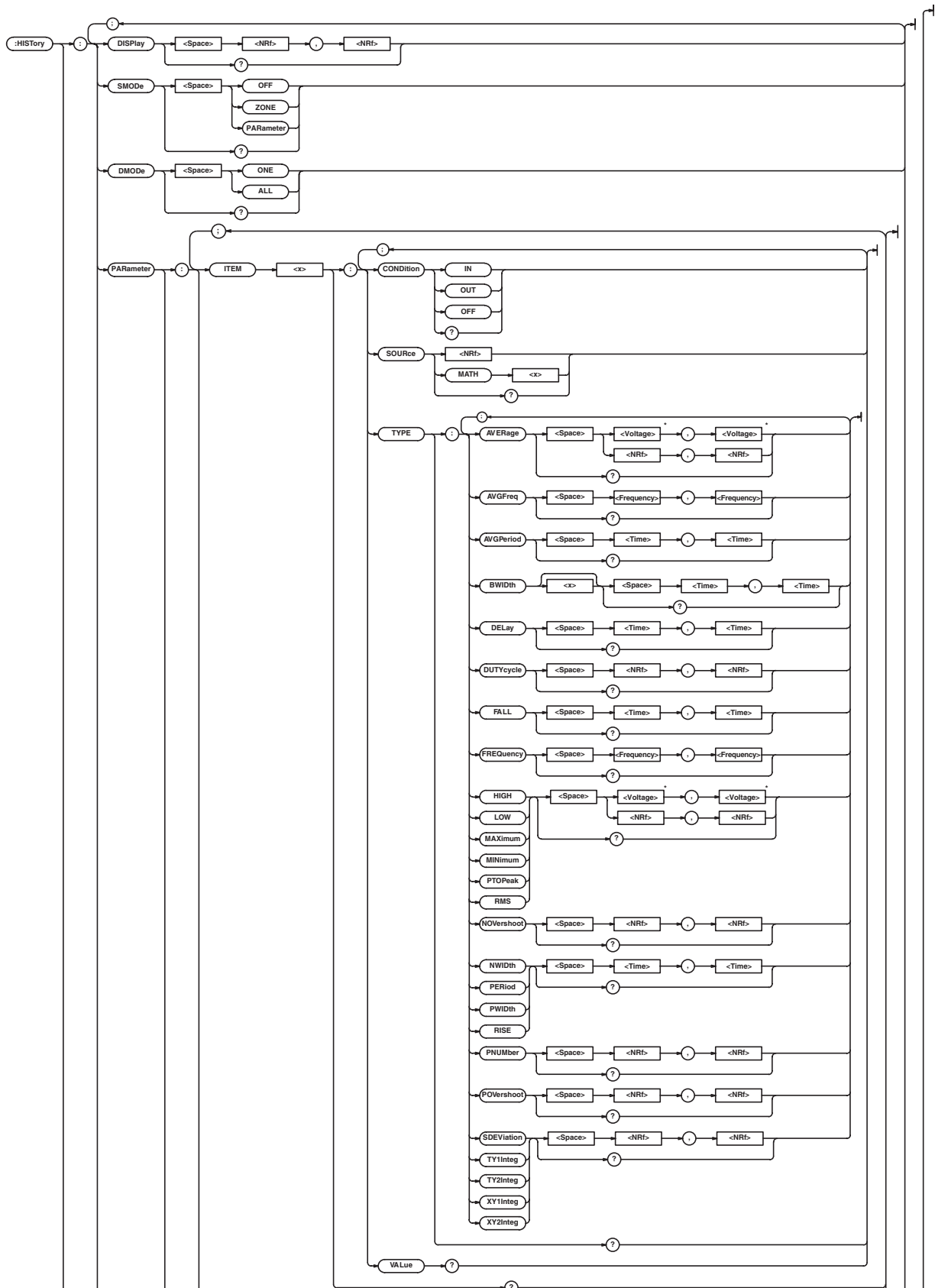

5.13 HISTory Group

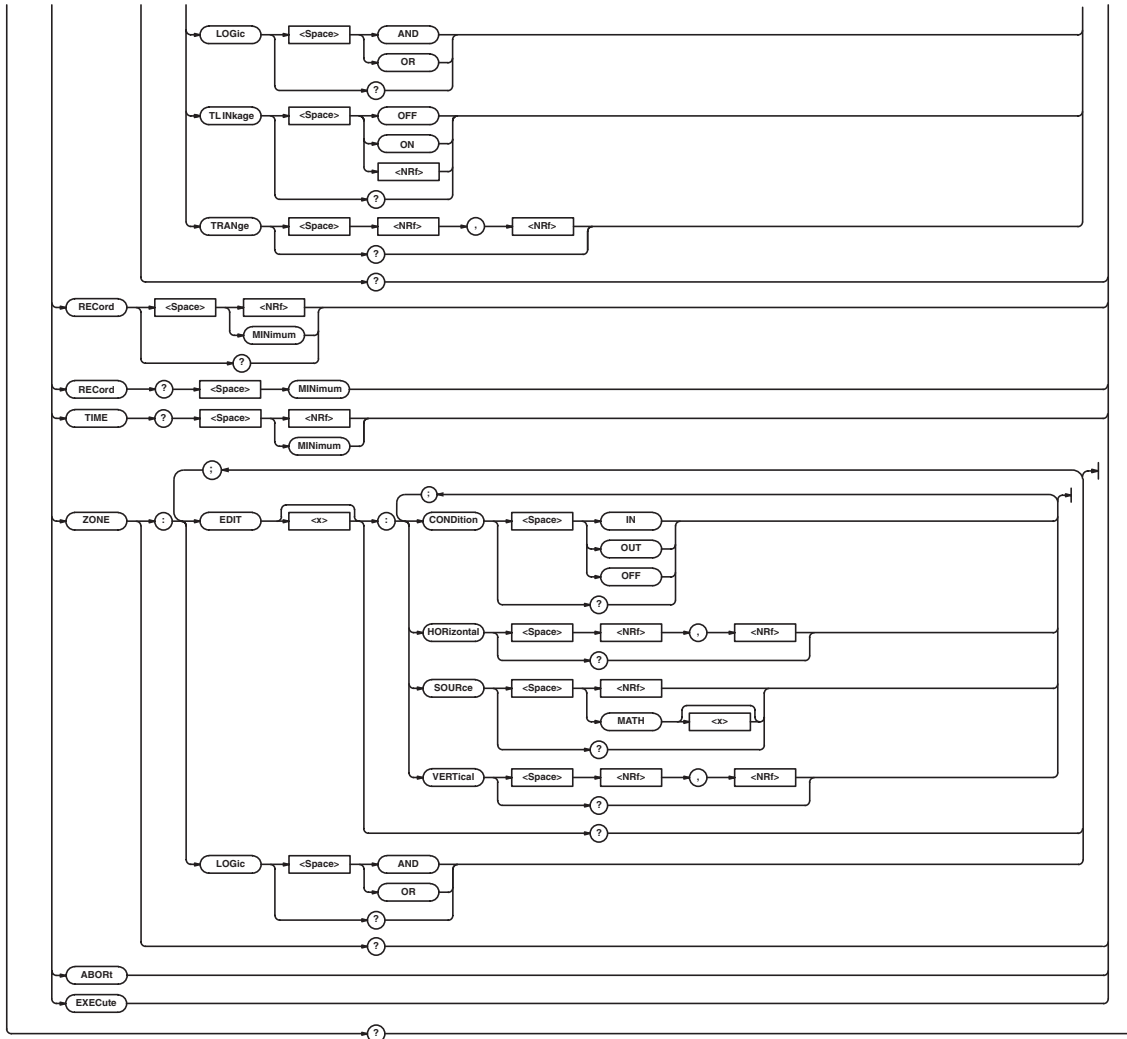

* When the target channel is set to the current probe, becomes <Current>.

:HISTory?

Function Queries all settings related to the history memory function.

Syntax :HISTory?

Example :HISTory? -> :HISTory:RECORD 0;
 DMODE ONE;DISPLAY 0,-127;SMODE OFF;
 ZONE:EDIT1:CONDITION OFF;SOURCE 1;
 HORIZONTAL 0.50,-0.50;
 VERTICAL -3.0000000,-2.5000000;:
 HISTory:ZONE:EDIT2:CONDITION OFF;
 SOURCE 1;HORIZONTAL 0.50,-0.50;
 VERTICAL -1.0000000,-0.5000000;:
 HISTory:ZONE:EDIT3:CONDITION OFF;
 SOURCE 1;HORIZONTAL 0.50,-0.50;
 VERTICAL 1.0000000,1.5000000;:
 HISTory:ZONE:EDIT4:CONDITION OFF;
 SOURCE 1;HORIZONTAL 0.50,-0.50;
 VERTICAL 3.0000000,3.5000000;:
 HISTory:ZONE:LOGIC AND;:HISTory:
 PARAMETER:ITEM1:CONDITION OFF;
 SOURCE 1;TYPE:P TOPEAK DONTCARE,
 DONTCARE;:HISTory:PARAMETER:ITEM2:
 CONDITION OFF;SOURCE 1;TYPE:
 MAXIMUM DONTCARE,DONTCARE;:HISTory:
 PARAMETER:ITEM3:CONDITION OFF;
 SOURCE 1;TYPE:MINIMUM DONTCARE,
 DONTCARE;:HISTory:PARAMETER:ITEM4:
 CONDITION OFF;SOURCE 1;TYPE:
 RMS DONTCARE,DONTCARE;:HISTory:
 PARAMETER:LOGIC AND;TLINKAGE 0;
 TRANGE -5.0000000,5.0000000

:HISTory:ABORt

Function Aborts the history search.

Syntax :HISTory:ABORt

Example :HISTory:ABORt

:HISTory:DISPlay

Function Sets the start number or end number of the display record of the history memory waveform or queries the current setting.

Syntax :HISTory:DISPlay {<Nrf>,<Nrf>}
 :HISTory:DISPlay?
 <Nrf>= 0 to -1023 (DL1720E)
 0 to -2047 (DL1740E/DL1740EL)

Example :HISTory:DISPlay 0,-100
 :HISTory:DISPlay? ->
 :HISTory:DISPlay 0,-100

Description The number of records that can be specified varies depending on the acquisition setting. For details, see the User's Manual.

:HISTory:EXECute

Function Executes the history search. This is an overlap command.

Syntax :HISTory:EXECute

Example :HISTory:EXECUTE

:HISTory:DMODE (Display Mode)

Function Sets the display mode of the history memory waveform or queries the current setting.

Syntax :HISTory:DMODE {ONE|ALL}
 :HISTory:DMODE?

Example :HISTory:DMODE ALL
 :HISTory:DMODE? ->
 :HISTory:DMODE ALL

Description If "ALL" is specified, the records that are specified with the ":HISTory:DISPlay" command are accumulated on the screen.

:HISTory:PARAMeter?

Function Queries all settings related to the history search (waveform parameter).

Syntax :HISTory:PARAMeter?

Example :HISTory:PARAMETER? -> :HISTory:
 PARAMETER:ITEM1:CONDITION OFF;
 SOURCE 1;TYPE:
 P TOPEAK DONTCARE,DONTCARE;:
 HISTory:PARAMETER:ITEM2:
 CONDITION OFF;SOURCE 1;TYPE:
 MAXIMUM DONTCARE,DONTCARE;:HISTory:
 PARAMETER:ITEM3:CONDITION OFF;
 SOURCE 1;TYPE:
 MINIMUM DONTCARE,DONTCARE;:HISTory:
 PARAMETER:ITEM4:CONDITION OFF;
 SOURCE 1;TYPE:
 RMS DONTCARE,DONTCARE;:HISTory:
 PARAMETER:LOGIC AND;TLINKAGE 0;
 TRANGE -5.0000000,5.0000000

:HISTory:PARAMeter:ITEM<x>?

Function Queries all settings related to the waveform parameter of the history search (waveform parameter).

Syntax :HISTory:PARAMeter:ITEM<x>?
 <x>=1 to 4

Example :HISTory:PARAMETER:ITEM1? ->
 :HISTory:PARAMETER:ITEM1:
 CONDITION OFF;SOURCE 1;TYPE:
 P TOPEAK DONTCARE,DONTCARE

:HISTory:PARAMeter:ITEM<x>:CONDition

Function Sets the criteria of the waveform parameter of the history search (waveform parameter) or queries the current setting.

Syntax :HISTory:PARAMeter:ITEM<x>:
 CONDition {OFF|IN|OUT}
 :HISTory:PARAMeter:ITEM<x>:
 CONDition?
 <x>=1 to 4

Example :HISTory:PARAMETER:ITEM1:
 CONDITION IN
 :HISTory:PARAMETER:ITEM1:
 CONDITION? ->
 :HISTory:PARAMETER:ITEM1:
 CONDITION IN

5.13 HISTory Group

:HISTory:PARAmeter:ITEM<x>:SOURCE

Function Sets the target waveform of the waveform parameter of the history search (waveform parameter) or queries the current setting.

Syntax `:HISTory:PARAmeter:ITEM<x>:SOURCE {<NRf> | MATH<x>}`
`:HISTory:PARAmeter:ITEM<x>:SOURCE? <x> of ITEM<x>=1 to 4`
`<NRf>=1 to 4 (1 to 2 on the DL1720E)`
`<x> of MATH<x>=1 or 2 (1 on the DL1720E)`

Example `:HISTory:PARAmeter:ITEM1:SOURCE 1`
`:HISTory:PARAmeter:ITEM1:SOURCE? ->`
`:HISTory:PARAmeter:ITEM1:SOURCE 1`

:HISTory:PARAmeter:ITEM<x>:TYPE: <parameter>

Function Sets the automated measurement parameter and its upper and lower limits of the waveform parameter of the history search (waveform parameter) or queries the current setting.

Syntax `:HISTory:PARAmeter:ITEM<x>:TYPE: <Parameter> {<{Voltage|DONTcare}>, <{Voltage|DONTcare}>|<{Time|DONTcare}>, <{Time|DONTcare}>| <{Frequency|DONTcare}>, <Frequency|DONTcare}>|<{<NRf>|DONTcare}>, <{<NRf>|DONTcare}>}`
`:HISTory:PARAmeter:ITEM<x>:TYPE? <Parameter>={AVERAge|AVGFreq|AVGPeriod|BWIDTH1|BWIDTH2|DELAY|DUTYcycle|FALL|FREQUency|HIGH|LOW|MAXimum|MINimum|NOVershoot|NWIDth|PERiod|PNUMber|POVershoot|PTOPeak|PWIDth|RISE|RMS|SDEVIation|TY1Integ|TY2Integ|XY1Integ|XY2Integ} <x>=1 to 4`
`<Voltage>, <Time>, <Frequency>, <NRf>=See the User's Manual.`

Example `:HISTory:PARAmeter:ITEM1:TYPE: AVERAGE 1.00,-1.00`

Description When a current probe is used, this command sets or queries the <Current> value.

:HISTory:PARAmeter:ITEM<x>:VALue?

Function Queries the automated measurement value of the waveform parameter of the history search (waveform parameter).

Syntax `:HISTory:PARAmeter:ITEM<x>:VALue? <x>=1 to 4`

Example `:HISTory:PARAmeter:ITEM1:VALue? ->`
`:HISTory:PARAmeter:ITEM1:VALue 1.00E-03`

:HISTory:PARAmeter:LOGic

Function Sets the search logic of the history search (waveform parameter) or queries the current setting.

Syntax `:HISTory:PARAmeter:LOGic {AND|OR}`

Example `:HISTory:PARAmeter:LOGic AND`
`:HISTory:PARAmeter:LOGic? ->`
`:HISTory:PARAmeter:LOGic AND`

:HISTory:PARAmeter:TLINKage

Function Turns ON/OFF the linked movement of the determination range cursor of the history search (waveform parameter) or queries the current setting.

Syntax `:HISTory:PARAmeter:TLINKage {<Boolean>}`
`:HISTory:PARAmeter:TLINKage?`

Example `:HISTory:PARAmeter:TLINKage ON`
`:HISTory:PARAmeter:TLINKage ->`
`:HISTory:PARAmeter:TLINKage 1`

:HISTory:PARAmeter:TRANge

Function Sets the determination range of the history search (waveform parameter) or queries the current setting.

Syntax `:HISTory:PARAmeter:TRANge {<NRf>, <NRf>}`
`:HISTory:PARAmeter:TRANge? <NRf>=-5.00 to 5.00 (10 div/displayed record length steps)`

Example `:HISTory:PARAmeter:TRANge -5.00,5.00`
`:HISTory:PARAmeter:TRANge? ->`
`:HISTory:PARAmeter:TRANge -5.00,5.00`

:HISTory:RECORD

Function Sets the target record of the history memory waveform or queries the current setting.

Syntax `:HISTory:RECORD {<NRf>|MINimum}`
`:HISTory:RECORD? <NRf>= 0 to -1023 (DL1720E)`
`0 to -2047 (DL1740E/DL1740EL)`

Example `:HISTory:RECORD 0`
`:HISTory:RECORD? ->`
`:HISTory:RECORD 0`

Description

- If "MINimum" is specified, the minimum record number is selected.
- The selectable target record varies depending on record length, and interleave mode settings. For details, see the User's Manual.

:HISTory:RECORD? MINimum

Function Queries the minimum record number.

Syntax `:HISTory:RECORD? MINimum`

Example `:HISTory:RECORD? MINimum -> -999`

Description The minimum record number varies depending on record length, and interleave mode settings. For details, see the User's Manual.

:HISTory:SMODE (Search Mode)

Function Sets the search mode of the history memory waveform or queries the current setting.

Syntax `:HISTory:SMODE {OFF|ZONE|PARAmeter}`
`:HISTory:SMODE?`

Example `:HISTory:SMODE ZONE`
`:HISTory:SMODE? ->`
`:HISTory:SMODE ZONE`

:HISTory:TIME?

Function Queries the time of the target record number of the history memory waveform.

Syntax :HISTory:TIME? {<NRf>|MINimum}

Example :HISTory:TIME? -100 ->
:HISTory:TIME " -0100 10:20:30.40"

Description If "MINimum" is specified, the minimum record number is selected.

:HISTory:ZONE?

Function Queries all settings related to the history search (zone).

Syntax :HISTory:ZONE?

Example :HISTory:ZONE? -> :HISTory:ZONE:
EDIT1:CONDITION OFF;SOURCE 1;
HORIZONTAL 0.50,-0.50;
VERTICAL -3.0000000,-1.0000000;:
HISTory:ZONE:EDIT2:CONDITION OFF;
SOURCE 1;HORIZONTAL 0.50,-0.50;
VERTICAL -1.0000000,1.0000000;:
HISTory:ZONE:EDIT3:CONDITION OFF;
SOURCE 1;HORIZONTAL 0.50,-0.50;
VERTICAL 1.0000000,3.0000000;:
HISTory:ZONE:EDIT4:CONDITION OFF;
SOURCE 1;HORIZONTAL 0.50,-0.50;
VERTICAL 3.0000000,-2.5000000;:
HISTory:ZONE:LOGIC AND

:HISTory:ZONE:EDIT<x>?

Function Queries all settings related to the search zone of the history search (zone).

Syntax :HISTory:ZONE:EDIT<x>?
<x>=1 to 4

Example :HISTory:ZONE:EDIT1? ->
:HISTory:ZONE:EDIT1:CONDITION OFF;
SOURCE 1;HORIZONTAL 0.50,-0.50;
VERTICAL -3.0000000,-1.0000000

Description When a current probe is used, this command sets or queries the <Current> value.

:HISTory:ZONE:EDIT<x>:CONDition

Function Sets the search condition of the history search (zone) or queries the current setting.

Syntax :HISTory:ZONE:EDIT<x>:CONDition
{OFF|IN|OUT}

Example :HISTory:ZONE:EDIT1:CONDition IN
:HISTory:ZONE:EDIT1:CONDition? ->
:HISTory:ZONE:EDIT1:CONDition IN

Description Use EDIT<x> to specify the desired search zone.

:HISTory:ZONE:EDIT<x>:HORizontal

Function Sets the horizontal position of the zone of the history search (zone) or queries the current setting.

Syntax :HISTory:ZONE:EDIT<x>:HORizontal
{<NRf>,<NRf>}

Example :HISTory:ZONE:EDIT1:
HORIZONTAL 4.00,-4.00
:HISTory:ZONE:EDIT1:HORIZONTAL? ->
:HISTory:ZONE:EDIT1:
HORIZONTAL 4.00,-4.00

Description Use EDIT<x> to specify the desired search zone.

:HISTory:ZONE:EDIT<x>:SOURCE

Function Sets the target waveform of the history search (zone) or queries the current setting.

Syntax :HISTory:ZONE:EDIT<x>:SOURCE
{<NRf>|MATH<x>}

Example :HISTory:ZONE:EDIT1:SOURCE 1
:HISTory:ZONE:EDIT1:SOURCE? ->
:HISTory:ZONE:EDIT1:SOURCE 1

Description Use EDIT<x> to specify the desired search zone.

:HISTory:ZONE:EDIT<x>:VERTical

Function Sets the vertical position of the zone of the history search (zone) or queries the current setting.

Syntax :HISTory:ZONE:EDIT<x>:VERTical
{<NRf>,<NRf>}

Example :HISTory:ZONE:EDIT1:VERTICAL -2,2
:HISTory:ZONE:EDIT1:VERTICAL? ->
:HISTory:ZONE:EDIT1:
VERTICAL -2.0000000,2.0000000

Description Use EDIT<x> to specify the desired search zone.

:HISTory:ZONE:LOGic

Function Sets the search logic condition of the history search (zone) or queries the current setting.

Syntax :HISTory:ZONE:LOGic {AND|OR}

Example :HISTory:ZONE:LOGic AND
:HISTory:ZONE:LOGic? ->
:HISTory:ZONE:LOGic AND

5.14 IMAGE Group

5.14 IMAGE Group

Use this group to set or query the screen image data save settings. You can make the same settings, execute the same operations, and make the same inquiries of settings as when (SHIFT+) IMAGE SAVE on the front panel is used.

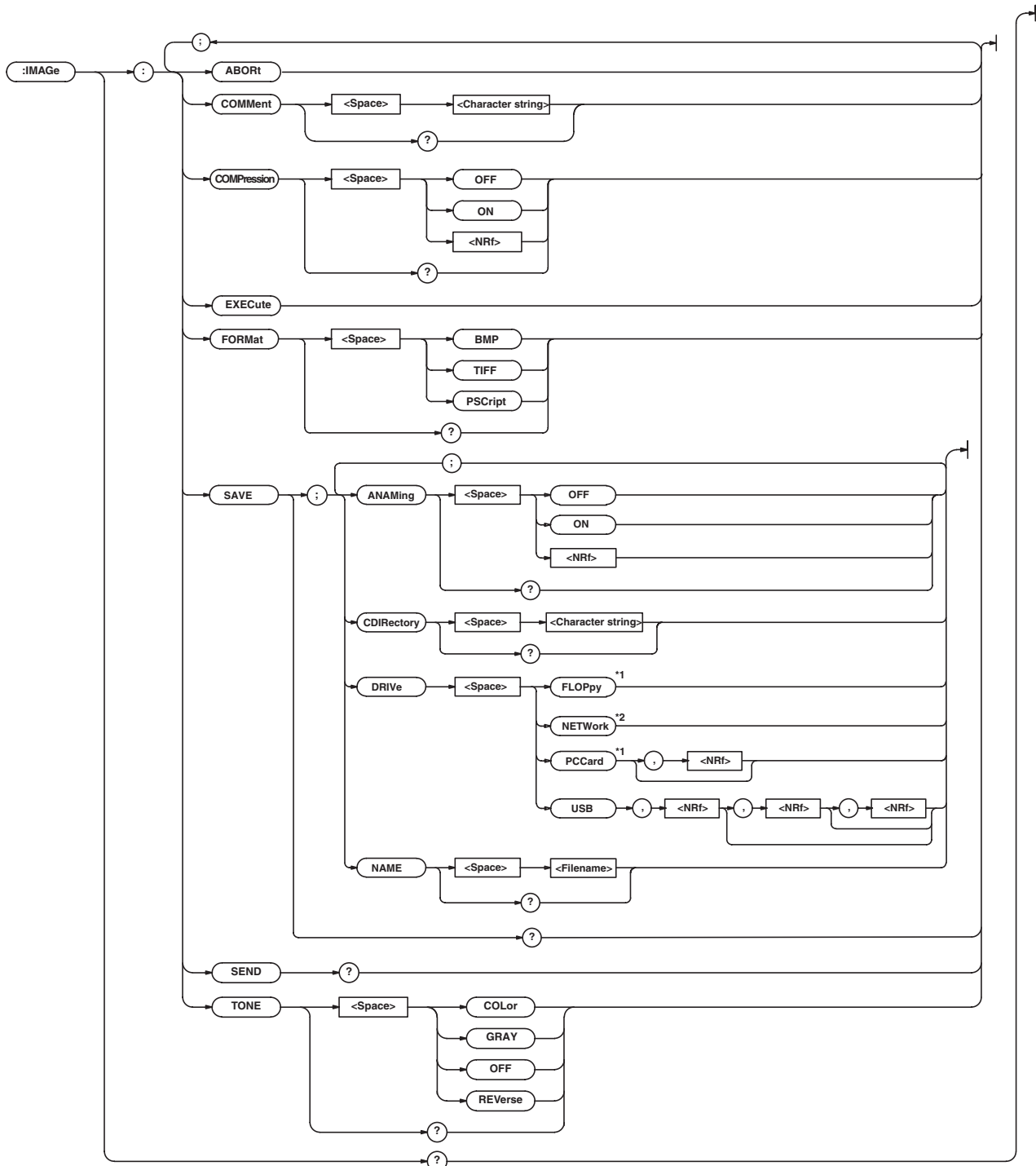

*1 "FLOPPY" can be used when the built-in floppy disk drive is available; "PCCard" can be used when the built-in PC card interface is available.

*2 "NETWORK" can be used when the Ethernet interface (option) is installed.

: IMAGE?

Function Queries all screen image data save settings.
 Syntax IMAGE?
 Example :IMAGE? -> :IMAGE:FORMAT TIFF;
 TONE OFF;COMMENT "";COMPRESSION 0;
 SAVE:ANAMING 1;NAME ""

: IMAGE:ABORT

Function Aborts saving the screen image data to the storage medium.
 Syntax :IMAGE:ABORT
 Example :IMAGE:ABORT

: IMAGE:COMMENT

Function Sets the comment at the lower part of the screen or queries the current setting.
 Syntax :IMAGE:COMMENT <Character string>
 :IMAGE:COMMENT?
 <Character string>=Up to 20 characters
 Example :IMAGE:COMMENT "THIS IS TEST."
 :IMAGE:COMMENT? ->
 :IMAGE:COMMENT "THIS IS TEST."

: IMAGE:COMPRESSION

Function Sets the screen image data compression of the TIFF format or queries the current setting.
 Syntax :IMAGE:COMPRESSION {<Boolean>}
 :IMAGE:COMPRESSION?
 Example :IMAGE:COMPRESSION
 ON:IMAGE:COMPRESSION? ->
 :IMAGE:COMPRESSION 1
 Description This setting is valid when saving to the external storage medium.

: IMAGE:EXECUTE

Function Stores the screen image data to the storage medium.
 Syntax :IMAGE:EXECUTE
 Example :IMAGE:EXECUTE

: IMAGE:FORMAT

Function Sets the save format of the screen image data or queries the current setting.
 Syntax :IMAGE:FORMAT
 {TIFF|BMP|PSCRIPT|PNG|JPEG}
 :IMAGE:FORMAT?
 Example :IMAGE:FORMAT TIFF
 :IMAGE:FORMAT? ->
 :IMAGE:FORMAT TIFF

: IMAGE:SAVE?

Function Queries all settings related to the save operation of the screen image data to the storage medium.
 Syntax :IMAGE:SAVE?
 Example :IMAGE:SAVE? -> :IMAGE:SAVE:
 DRIVE FLOPPY;DIRECTORY "NO_1";
 ANAMING 0;NAME "DISP_1"

: IMAGE:SAVE:ANAMING

Function Turns ON/OFF the auto naming function of output file names or queries the current setting.
 Syntax :IMAGE:ANAMING {<Boolean>}
 :IMAGE:SAVE:ANAMING?
 Example :IMAGE:ANAMING ON
 :IMAGE:SAVE:ANAMING? ->
 :IMAGE:SAVE:ANAMING 1

: IMAGE:SAVE:CDIRECTORY

Function Changes the directory in which to save the screen image data.
 Syntax :IMAGE:SAVE:DIRECTORY <Character string>
 <Character string>=Up to 8 characters.
 Example :IMAGE:SAVE:DIRECTORY "NO_1"

: IMAGE:SAVE:DRIVE

Function Sets the storage medium for the file used to save the screen image data.
 Syntax :IMAGE:SAVE:DRIVE
 {FLOPPY|ZIP|PCARD[,<NRF>]|
 SCSI,<NRF>[,<NRF>]|NETWORK|USB,<NRF>
 [,<NRF>][,<NRF>]}
 <NRF> of PCARD=Partitions (0 to 3)
 USB's initial <NRF> = USB address
 USB's 2nd <NRF> = partition (0 to 3) or LUN
 (logical unit number: 0 to 3)
 USB's 3rd <NRF> = partition (0 to 3) when LUN
 specified for 2nd <NRF>
 Example :IMAGE:SAVE:DRIVE FLOPPY
 :IMAGE:SAVE:DRIVE? ->
 :IMAGE:SAVE:DRIVE FLOPPY
 Description • If the drive does not contain partitions, omit the <NRF> corresponding to partitions.
 "NETWORK" can be used when the Ethernet interface (option) is installed.
 • USB's 2nd and 3rd <NRF> can be omitted when not delimited by partitions or LUN.

: IMAGE:SAVE:NAME

Function Sets the name of the file to be saved or queries the current setting.
 Syntax :IMAGE:SAVE:NAME <Filename>
 :IMAGE:SAVE:NAME?
 Example :IMAGE:SAVE:NAME "DISP_1"
 :IMAGE:SAVE:NAME? ->
 :IMAGE:SAVE:NAME "DISP_1"

: IMAGE:SEND?

Function Queries screen image data.
 Syntax :IMAGE:SEND?
 Example :IMAGE:SEND? -> #6 (number of bytes[6-digit value]) (Data byte string) (Block data)
 Description Number of bytes in <block data> is {(2+6+Number of data+1(delimiter))}. For information about block data, refer to page 4-6.

: IMAGE:TONE

Function Sets/queries the color tone of the BMP (TIFF) format of the screen image data to save.
 Syntax :IMAGE:TONE
 {COLOR|OFF|REVERSE|GRAY}
 :IMAGE:TONE?
 Example :IMAGE:TONE COLOR
 :IMAGE:TONE? -> :IMAGE:TONE COLOR

5.15 INITIALize Group

5.15 INITialize Group

The commands in the INITialize group are related to initializing. You can make the same settings using the Initialize menu of SETUP on the front panel.

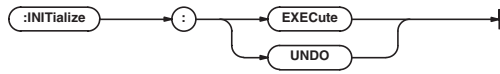

:INITialize:EXECute

Function Executes initializing.
Syntax :INITialize:EXECute
Example :INITIALIZE:EXECUTE

:INITialize:UNDO

Function Nullifies initializing.
Syntax :INITialize:UNDO
Example :INITIALIZE:UNDO

5.16 MATH Group

The commands in the MATH group are used to make settings and queries about computation. You can make the same settings that you can make using MATH on the front panel.

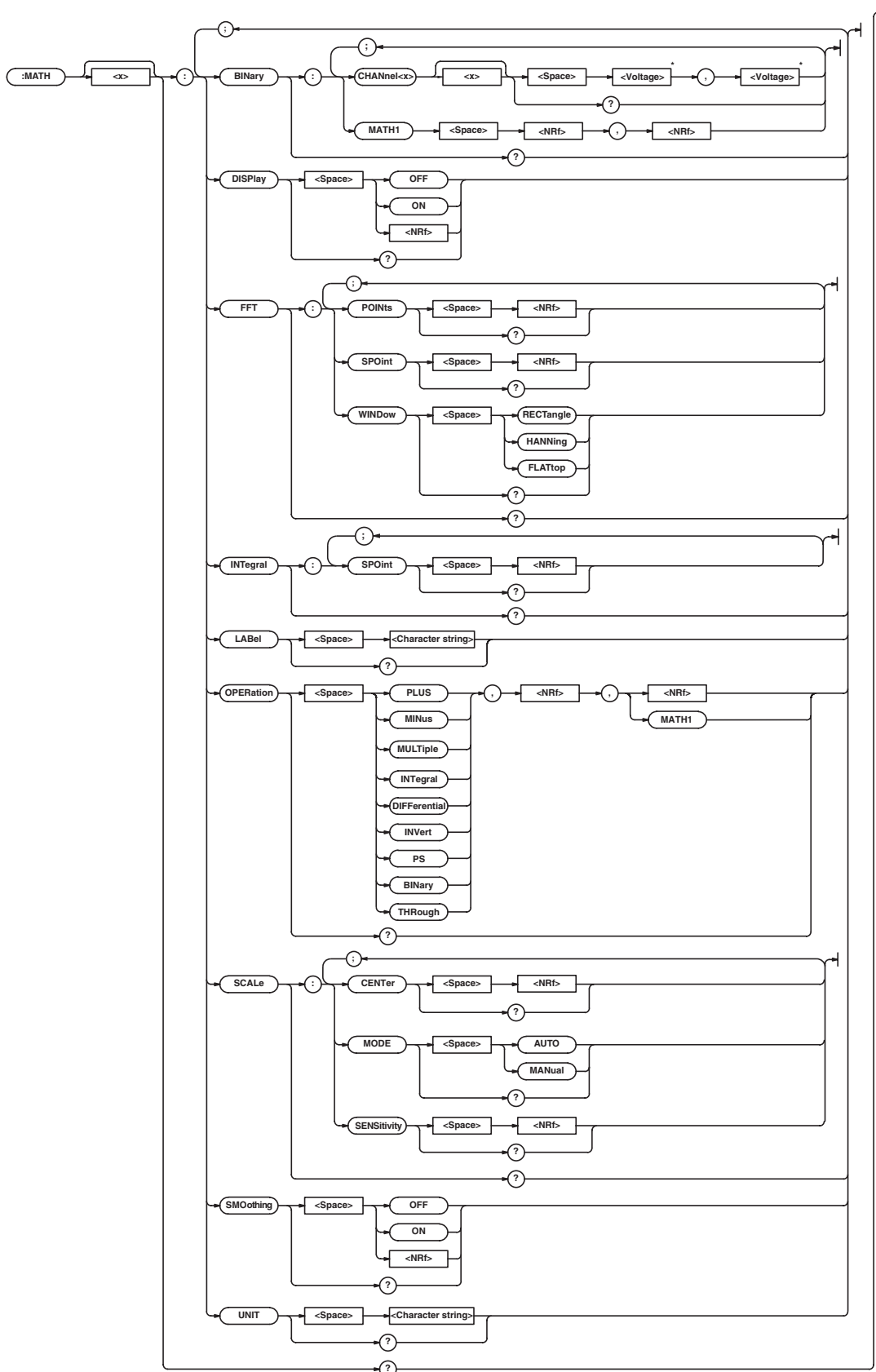

* When the target channel is set to the current probe, becomes <Current>.

5.16 MATH Group

:MATH<x>?

Function Queries all settings relating to computation.
Syntax **:MATH<x>?**
<x>=1, 2 (1 on the DL1720E)
Example **:MATH1? -> :MATH1:DISPLAY 0;SCALE:MODE AUTO;CENTER 0.00000E+00;SENSITIVITY 100.000E+00;-400.000E+00;:MATH1:OPERATION PLUS,1,2;FFT:POINTS 1000;WINDOW HANNING;SPOINT -5.0000000;:MATH1:BINARy:CHANNEL1 0.0E+00,0.0E+00;CHANNEL2 0.0E+00,0.0E+00;CHANNEL3 0.0E+00,0.0E+00;CHANNEL4 0.0E+00,0.0E+00;MATH1 0.00,0.00;:MATH1:INTEGRAL:SPOINT -5.0000000;:MATH1:SMOOTHING 0;UNIT "EU";LABEL "Math1"**

:MATH<x>:BINARy?

Function Queries all settings related to binary computations.
Syntax **:MATH<x>:BINARy?**
<x>=1 or 2 (1 on the DL1720E)
Example **:MATH1:BINARy? -> :MATH1:BINARy:CHANNEL1 0.0E+00,0.0E+00;CHANNEL2 0.0E+00,0.0E+00;CHANNEL3 0.0E+00,0.0E+00;CHANNEL4 0.0E+00,0.0E+00;MATH1 0.00,0.00**

:MATH<x>:BINARy:{CHANnel<x>|MATH1}

Function Sets the threshold levels of the channel for binary computation or queries the current setting.
Syntax **:MATH<x>:BINARy:{CHANnel<x>|MATH1}{<Voltage>,<Voltage>|<Nrf>,<Nrf>}**
<x> of MATH<x>=1 or 2 (1 on the DL1720E)
<x> of CHANnel<x>=1 to 4 (1 to 2 on the DL1720E)
<Voltage>=8 divisions within the screen (0.01 division steps)
<Nrf>=-4 to 4 div (0.01 div steps)
Example **:MATH1:BINARy:CHANnel1 0V,0V;:MATH1:BINARy:CHANnel1? -> :MATH1:BINARy:CHANnel1 0.000E+00,0.000E+00**
Description

- The **:MATH<x>:BINARy:MATH1** command can be used when <x>=2. An error occurs if <x>=1. (There is no MATH2 on the DL1720E so this command cannot be used.)
- When a current probe is used, this command sets or queries the <Current> value.

:MATH<x>:DISPlay

Function Sets whether or not to display computation waveforms or queries the current setting.
Syntax **:MATH<x>:DISPlay {<Boolean>}**
:MATH<x>:DISPlay?
<x>=1 or 2 (1 on the DL1720E)
Example **:MATH1:DISPlay ON;:MATH1:DISPlay? -> :MATH1:DISPlay 1**

:MATH<x>:FFT?

Function Queries all FFT computation settings.
Syntax **:MATH<x>:FFT?**
<x>=1 or 2 (1 on the DL1720E)
Example **:MATH1:FFT? -> :MATH1:FFT:POINTS 1000;WINDOW RECTANGLE;SPOINT -5.0000000**

:MATH<x>:FFT:POINTs

Function Sets/queries the number of points for FFT computation.
Syntax **:MATH<x>:FFT:POINTs {<Nrf>}**
:MATH<x>:FFT:POINTs?
<x>=1 or 2 (1 on the DL1720E)
<Nrf>=1000, 10000
Example **:MATH1:FFT:POINTs 1000;:MATH1:FFT:POINTs? -> :MATH1:FFT:POINTs 1000**

:MATH<x>:FFT:SPOint (Start Point)

Function Sets the start point of the FFT or queries the current setting.
Syntax **:MATH<x>:FFT:SPOint {<Nrf>}**
:MATH<x>:FFT:SPOint?
<x>=1 or 2 (1 on the DL1720E)
<Nrf>=-5 to 5 div (10 div/displayed record length steps)
Example **:MATH1:FFT:SPOint 1.5;:MATH1:FFT:SPOint? -> :MATH1:FFT:SPOint 1.5000000**

:MATH<x>:FFT:WINDow

Function Sets/queries FFT window function.
Syntax **:MATH<x>:FFT:WINDow {FLATtop|HANNing|RECTangle}**
:MATH<x>:FFT:WINDow?
<x>=1 or 2 (1 on the DL1720E)
Example **:MATH1:FFT:WINDow HANNING;:MATH1:FFT:WINDow? -> :MATH1:FFT:WINDow HANNING**

:MATH<x>:INTEGRal?

Function Queries all settings related to integration.
Syntax **:MATH<x>:INTEGRal?**
<x>=1 or 2 (1 on the DL1720E)
Example **:MATH1:INTEGRal? -> :MATH1:INTEGRal:SPOINT -5.0000000**

:MATH<x>:INTEGRal:SPOint (Start Point)

Function Sets the start point of the integration or queries the current setting.
Syntax **:MATH<x>:INTEGRal:SPOint {<Nrf>}**
:MATH<x>:INTEGRal:SPOint?
<x>=1 or 2 (1 on the DL1720E)
<Nrf>=-5 to 5 div (10 div/displayed record length steps)
Example **:MATH1:INTEGRal:SPOint 1.5;:MATH1:INTEGRal:SPOint? -> :MATH1:INTEGRal:SPOint 1.5000000**

:MATH<x>:LABEL

Function	Sets the label of the computation waveform or queries the current setting.
Syntax	:MATH<x>:LABEL {<Character string>} :MATH<x>:LABEL? <x>=1 or 2 (1 on the DL1720E) <Character string>=Within 8 characters
Example	:MATH1:LABEL "MATH1" :MATH1:LABEL? -> :MATH1:LABEL "MATH1"

:MATH<x>:OPERation

Function	Sets the type of computation or queries the current setting.
Syntax	:MATH<x>:OPERation {PLUS MINus MULTiple BINary INVert DIFFerential INTEgral PS THROUGH}, {<NRf>}[, {<NRf> MATH1}] :MATH<x>:OPERation? <x>=1 or 2 (1 on the DL1720E) <NRf>=1 to 4 (1 to 2 on the DL1720E)
Example	:MATH1:OPERATION PLUS,1,2 :MATH1:OPERATION? -> :MATH1:OPERATION PLUS,1,2
Description	<ul style="list-style-type: none"> For unary operators (BINary INVert DIFFerential INTEgral PS THROUGH), select the waveform in the first <NRf>. For binomial operators (PLUS MINus MULTiple), select the first waveform in the first <NRf> and the second waveform in the second <NRf>. However, MATH1 can be selected for the second <NRf> only when using the DL1740E/DL1740EL.

:MATH<x>:SCALE?

Function	Queries all settings related to the scale conversion for normal computation.
Syntax	:MATH<x>:SCALE? <x>=1 to 2 (1 on the DL1720E)
Example	:MATH1:SCALE? -> :MATH1:SCALE: MODE AUTO;VALUE 200.000E+00,0.0E+00

:MATH<x>:SCALE:CENTer

Function	Sets the center value of the scale conversion for normal computation or queries the current setting.
Syntax	:MATH<x>:SCALE:CENTer {<NRf>} :MATH<x>:SCALE:CENTer? <x>=1 or 2 (1 on the DL1720E) <NRf>=-9.9999E+30 to 9.9999E+30
Example	:MATH1:SCALE:CENTer 1 :MATH1:SCALE:CENTer? -> :MATH1:SCALE:CENTer 1.00000E+00

:MATH<x>:SCALE:MODE

Function	Sets the scale conversion method for normal computation or queries the current setting.
Syntax	:MATH<x>:SCALE:MODE {AUTO MANual} :MATH<x>:SCALE:MODE? <x>=1 or 2 (1 on the DL1720E)
Example	:MATH1:SCALE:MODE AUTO :MATH1:SCALE:MODE? -> :MATH1:SCALE:MODE AUTO

:MATH<x>:SCALE:SENSitivity

Function	Sets the span from the center of the scale conversion for normal computation or queries the current setting.
Syntax	:MATH<x>:SCALE:SENSitivity {<NRf>} :MATH<x>:SCALE:SENSitivity? <x>=1 or 2 (1 on the DL1720E) <NRf>=-9.9999E+30 to 9.9999E+30
Example	:MATH1:SCALE:SENSITIVITY 10 :MATH1 SCALE:SENSITIVITY? -> :MATH1:SCALE: SENSITIVITY 10.0000E+00

:MATH<x>:SMOothing

Function	Turns smoothing ON/OFF for normal computation or queries the current setting.
Syntax	:MATH<x>:SMOothing {<Boolean>} :MATH<x>:SMOothing? <x>=1 or 2 (1 on the DL1720E)
Example	:MATH1:SMOOTHING ON :MATH1:SMOOTHING? -> :MATH1:SMOOTHING 1
Description	This command is void, if "PS" is selected with the "MATH<x>:OPERation" command.

:MATH<x>:UNIT

Function	Sets the unit to be added to the computed result for normal computation or queries the current setting.
Syntax	:MATH<x>:UNIT {<Character string>} :MATH<x>:UNIT? <x>=1 or 2 (1 on the DL1720E) <Character string>=Within 4 characters
Example	:MATH1:UNIT "EU" :MATH1:UNIT? -> :MATH1:UNIT "EU"
Description	The unit is reflected in the scale value. The unit setting has no effect on the calculation result.

5.17 MEASure Group

The commands in the MEASure group are used to make settings and queries about automatic measurement of waveform parameters^{*1}. You can make the same settings which you can make using MEASURE on the front panel.

*1 For waveform parameters, the displayed names on the DL1720E/DL1740E/DL1740EL screen may not match the names used by communication commands. A correspondence table is given in Appendix 4.

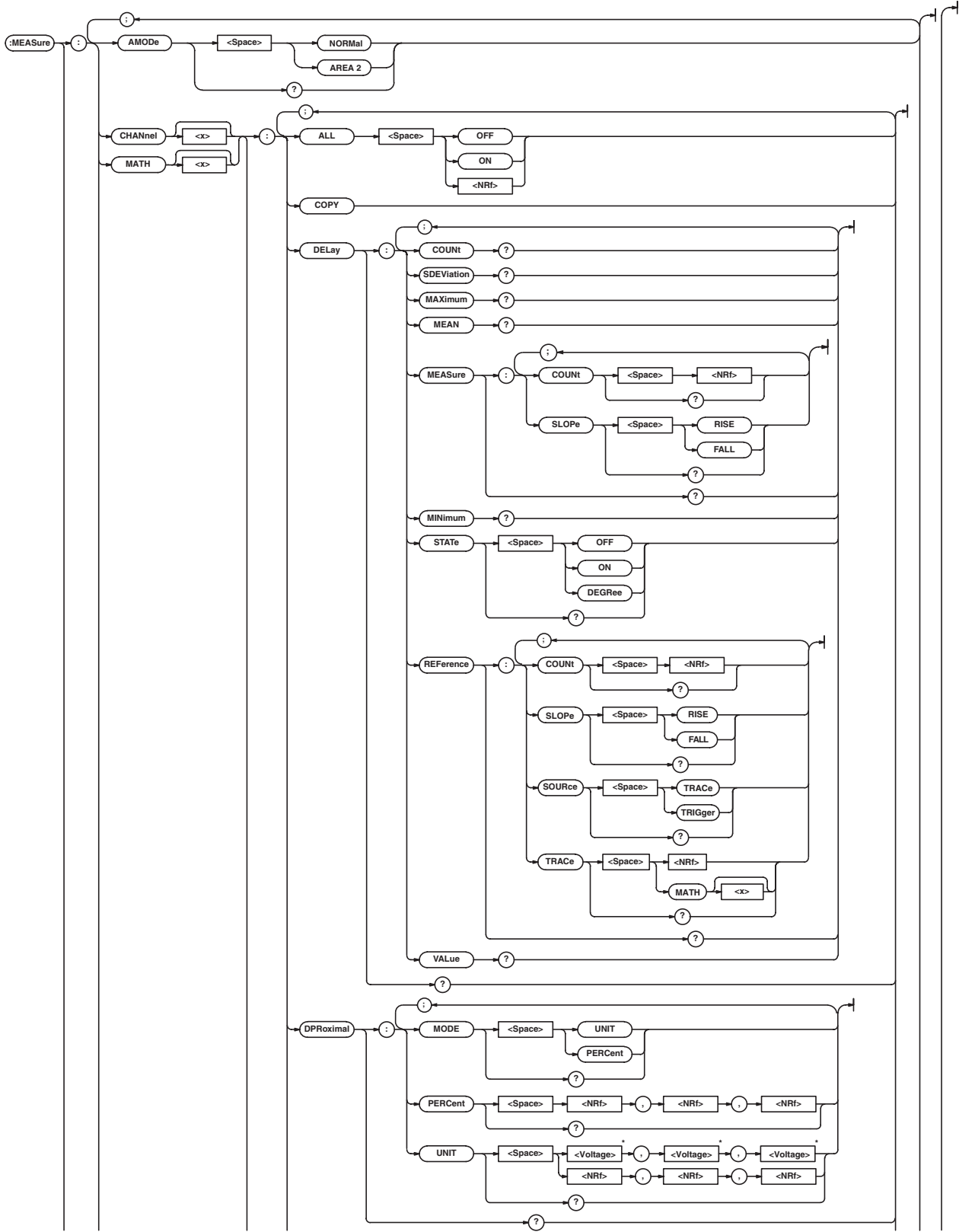

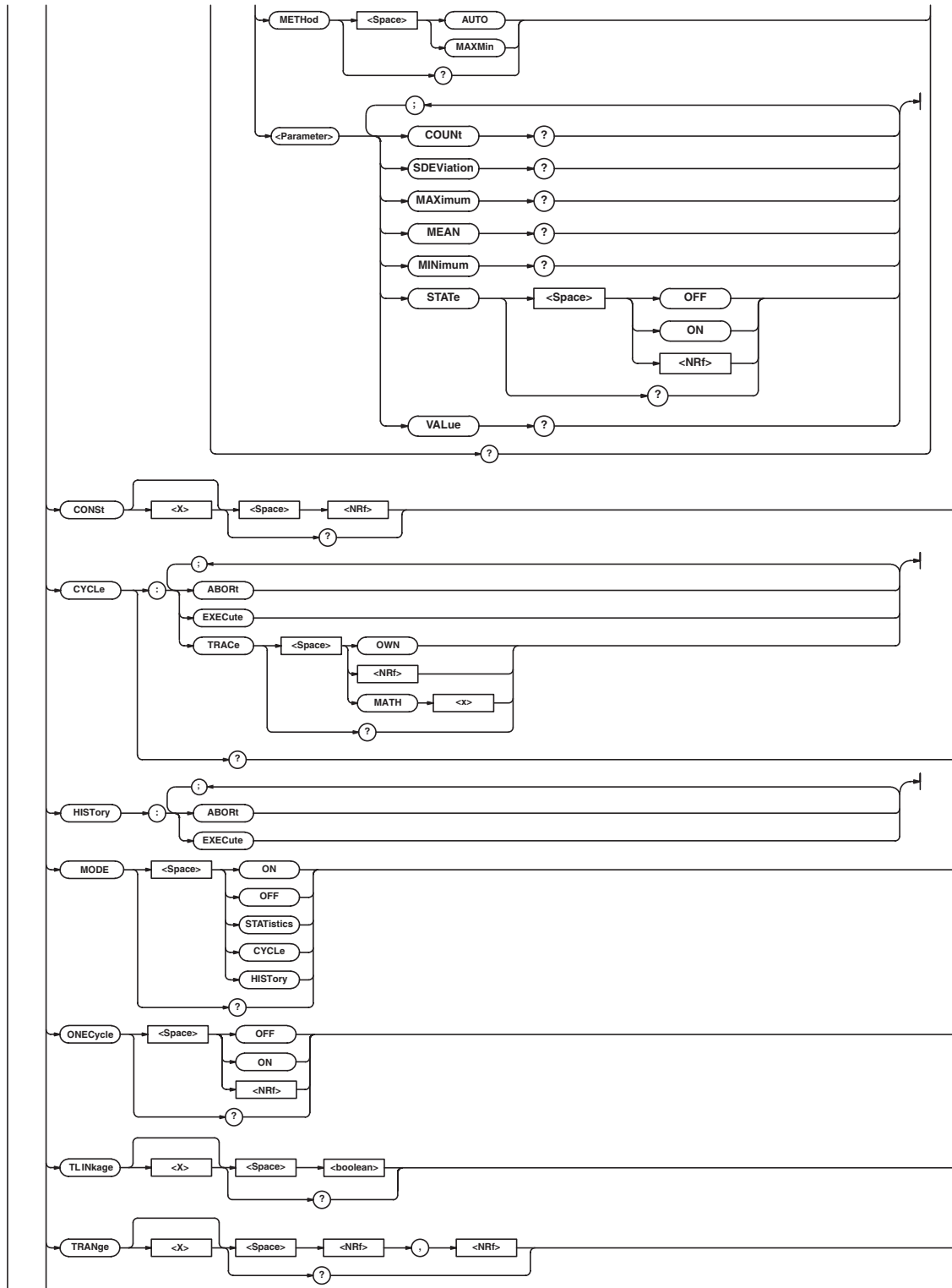

5.17 MEASure Group

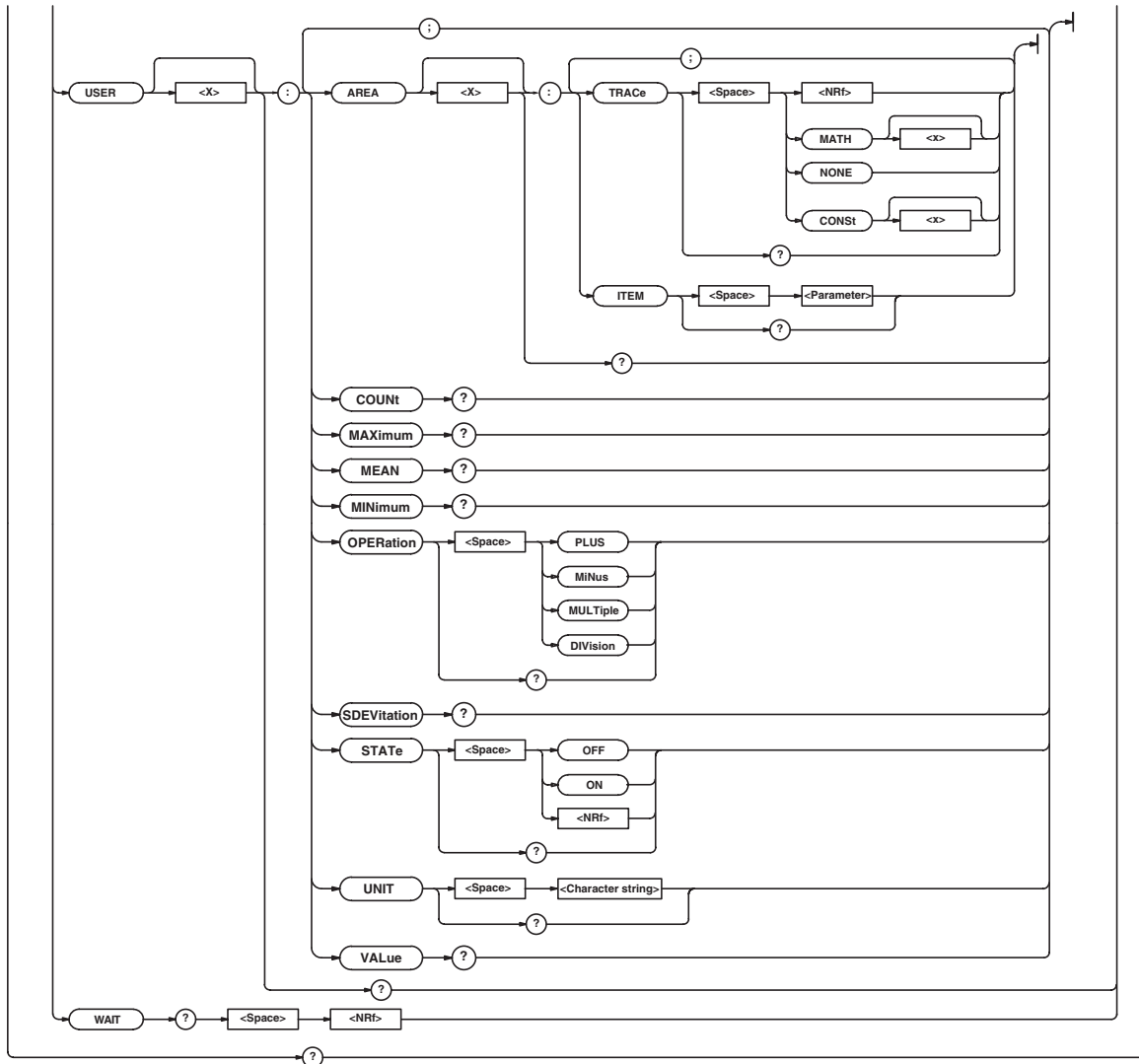

* When the target channel is set to the current probe, becomes <Current>.

:MEASure?

Function Queries all settings relating to automatic measurement of waveform parameters.

Syntax :MEASure?

Example :MEASure? -> :MEASURE:MODE ON;
 AMODE NORMAL;CHANNEL1:AVERAGE:
 STATE 0;:MEASURE:CHANNEL1:AVGFREQ:
 STATE 0;:MEASURE:CHANNEL1:
 AVGPERIOD:STATE 0;:MEASURE:
 CHANNEL1:BWIDTH1:STATE 0;:MEASURE:
 CHANNEL1:BWIDTH2:STATE 0;:MEASURE:
 CHANNEL1:DUTYCYCLE:STATE 0;:
 MEASURE:CHANNEL1:FALL:STATE 0;:
 MEASURE:CHANNEL1:FREQUENCY:
 STATE 0;:MEASURE:CHANNEL1:HIGH:
 STATE 0;:MEASURE:CHANNEL1:LOW:
 STATE 0;:MEASURE:CHANNEL1:MAXIMUM:
 STATE 0;:MEASURE:CHANNEL1:MINIMUM:
 STATE 0;:MEASURE:CHANNEL1:
 NOVERSHOOT:STATE 0;:MEASURE:
 CHANNEL1:NWIDTH:STATE 0;:MEASURE:
 CHANNEL1:PERIOD:STATE 0;:MEASURE:
 CHANNEL1:PNUMBER:STATE 0;:MEASURE:
 CHANNEL1:POVERSHOOT:STATE 0;:
 MEASURE:CHANNEL1:PTOPEAK:STATE 1;:
 MEASURE:CHANNEL1:PWIDTH:STATE 0;:
 MEASURE:CHANNEL1:RISE:STATE 0;:
 MEASURE:CHANNEL1:RMS:STATE 0;:
 MEASURE:CHANNEL1:SDEVIATION:
 STATE 0;:MEASURE:CHANNEL1:TY1INTEG:
 STATE 0;:MEASURE:CHANNEL1:TY2INTEG:
 STATE 0;:MEASURE:CHANNEL1:XY1INTEG:
 STATE 0;:MEASURE:CHANNEL1:XY2INTEG:
 STATE 0;:MEASURE:CHANNEL1:DELAY:
 STATE OFF;MEASURE:SLOPE RISE;
 COUNT 1;:MEASURE:CHANNEL1:DELAY:
 REFERENCE:SOURCE TRACE;TRACE 1;
 SLOPE RISE;COUNT 1;:MEASURE:
 CHANNEL1:DPROXIMAL:MODE PERCENT;
 PERCENT 10.0,50.0,90.0;
 UNIT -150.000E+00,0.0E+00,1
 50.000E+00;:MEASURE:CHANNEL1:
 METHOD AUTO;:MEASURE:CHANNEL2:
 AVERAGE:STATE 0;:MEASURE:CHANNEL2:
 AVGFREQ:STATE 0;:MEASURE:CHANNEL2:
 AVGPERIOD:STATE 0;:MEASURE:
 CHANNEL2:BWIDTH1:STATE 0;:MEASURE:
 CHANNEL2:BWIDTH2:STATE 0;:MEASURE:
 CHANNEL2:DUTYCYCLE:STATE 0;:
 MEASURE:CHANNEL2:FALL:STATE 0;:
 MEASURE:CHANNEL2:FREQUENCY:
 STATE 0;:MEASURE:CHANNEL2:HIGH:
 STATE 0;:MEASURE:CHANNEL2:LOW:
 STATE 0;:MEASURE:CHANNEL2:MAXIMUM:
 STATE 0;:MEASURE:CHANNEL2:MINIMUM:
 STATE 0;:MEASURE:CHANNEL2:
 NOVERSHOOT:STATE 0;:MEASURE:
 CHANNEL2:NWIDTH:STATE 0;:MEASURE:
 CHANNEL2:PERIOD:STATE 0;:MEASURE:
 CHANNEL2:PNUMBER:STATE 0;:MEASURE:
 CHANNEL2:POVERSHOOT:STATE 0;:
 MEASURE:CHANNEL2:PTOPEAK:STATE 0;:
 MEASURE:CHANNEL2:PWIDTH:STATE 0;:
 MEASURE:CHANNEL2:RISE:STATE 0;:
 MEASURE:CHANNEL2:RMS:STATE 0;:
 MEASURE:CHANNEL2:SDEVIATION:
 STATE 0;:MEASURE:CHANNEL2:TY1INTEG:
 STATE 0;:MEASURE:CHANNEL2:TY2INTEG:

STATE 0;:MEASURE:CHANNEL2:XY1INTEG:
 STATE 0;:MEASURE:CHANNEL2:XY2INTEG:
 STATE 0;:MEASURE:CHANNEL2:DELAY:
 STATE OFF;MEASURE:SLOPE RISE;
 COUNT 1;:MEASURE:CHANNEL2:DELAY:
 REFERENCE:SOURCE TRACE;TRACE 2;
 SLOPE RISE;COUNT 1;:MEASURE:
 CHANNEL2:DPROXIMAL:MODE PERCENT;
 PERCENT 10.0,50.0,90.0;
 UNIT -150.000E+00,0.0E+00,
 150.000E+00;:MEASURE:CHANNEL2:
 METHOD AUTO;:MEASURE:CHANNEL3:
 AVERAGE:STATE 0;:MEASURE:CHANNEL3:
 AVGFREQ:STATE 0;:MEASURE:CHANNEL3:
 AVGPERIOD:STATE 0;:MEASURE:
 CHANNEL3:BWIDTH1:STATE 0;:MEASURE:
 CHANNEL3:BWIDTH2:STATE 0;:MEASURE:
 CHANNEL3:DUTYCYCLE:STATE 0;:
 MEASURE:CHANNEL3:FALL:STATE 0;:
 MEASURE:CHANNEL3:FREQUENCY:
 STATE 0;:MEASURE:CHANNEL3:HIGH:
 STATE 0;:MEASURE:CHANNEL3:LOW:
 STATE 0;:MEASURE:CHANNEL3:MAXIMUM:
 STATE 0;:MEASURE:CHANNEL3:MINIMUM:
 STATE 0;:MEASURE:CHANNEL3:
 NOVERSHOOT:STATE 0;:MEASURE:
 CHANNEL3:NWIDTH:STATE 0;:MEASURE:
 CHANNEL3:PERIOD:STATE 0;:MEASURE:
 CHANNEL3:PNUMBER:STATE
 0;:MEASURE:CHANNEL3:POVERSHOOT:
 STATE0;:MEASURE:CHANNEL3:PTOPEAK:
 STATE 0;:MEASURE:CHANNEL3:PWIDTH:
 STATE 0;:MEASURE:CHANNEL3:RISE:
 STATE 0;:MEASURE:CHANNEL3:RMS:
 STATE 0;:MEASURE:CHANNEL3:
 SDEVIATION:STATE0;:MEASURE:CHANNEL3:
 TY1INTEG:STATE0;:MEASURE:CHANNEL3:
 TY2INTEG:STATE 0;:MEASURE:CHANNEL3:
 XY1INTEG:STATE 0;:MEASURE:CHANNEL3:
 XY2INTEG:STATE 0;:MEASURE:CHANNEL3:
 DELAY:STATE OFF;MEASURE:SLOPE RISE;
 COUNT 1;:MEASURE:CHANNEL3:DELAY:
 REFERENCE:SOURCE TRACE;TRACE 3;
 SLOPE RISE;COUNT 1;:MEASURE:
 CHANNEL3:DPROXIMAL:MODE PERCENT;
 PERCENT 10.0,50.0,90.0;
 UNIT -150.000E+00,0.0E+00,
 150.000E+00;:MEASURE:CHANNEL3:
 METHOD AUTO;:MEASURE:CHANNEL4:
 AVERAGE:STATE 0;:MEASURE:CHANNEL4:
 AVGFREQ:STATE 0;:MEASURE:CHANNEL4:
 AVGPERIOD:STATE 0;:MEASURE:
 CHANNEL4:BWIDTH1:STATE 0;:MEASURE:
 CHANNEL4:BWIDTH2:STATE 0;:MEASURE:
 CHANNEL4:DUTYCYCLE:STATE 0;:
 MEASURE:CHANNEL4:FALL:STATE 0;:
 MEASURE:CHANNEL4:FREQUENCY:
 STATE 0;:MEASURE:CHANNEL4:HIGH:
 STATE 0;:MEASURE:CHANNEL4:LOW:
 STATE 0;:MEASURE:CHANNEL4:MAXIMUM:
 STATE 0;:MEASURE:CHANNEL4:MINIMUM:
 STATE 0;:MEASURE:CHANNEL4:
 NOVERSHOOT:STATE 0;:MEASURE:
 CHANNEL4:NWIDTH:STATE 0;:MEASURE:
 CHANNEL4:PERIOD:STATE 0;:MEASURE:
 CHANNEL4:PNUMBER:STATE 0;:MEASURE:
 CHANNEL4:POVERSHOOT:STATE 0;:
 MEASURE:CHANNEL4:PTOPEAK:STATE 0;:

5.17 MEASure Group

```

MEASURE:CHANNEL4:PWIDTh:STATE 0;;
MEASURE:CHANNEL4:RISE:STATE 0;;
MEASURE:CHANNEL4:RMS:STATE 0;;
MEASURE:CHANNEL4:SDEVIATION:
STATE 0;;MEASURE:CHANNEL4:TY1INTEG:
STATE 0;;MEASURE:CHANNEL4:TY2INTEG:
STATE 0;;MEASURE:CHANNEL4:XY1INTEG:
STATE 0;;MEASURE:CHANNEL4:XY2INTEG:
STATE 0;;MEASURE:CHANNEL4:DELAY:
STATE OFF;MEASURE:SLOPE RISE;
COUNT 1;;MEASURE:CHANNEL4:DELAY:
REFERENCE:SOURCE TRACE;TRACE 4;
SLOPE RISE;COUNT 1;;MEASURE:
CHANNEL4:DPROXIMAL:MODE PERCENT;
PERCENT 10.0,50.0,90.0;
UNIT -150.000E+00,0.0E+00,
150.000E+00;;MEASURE:CHANNEL4:
METHOD AUTO;;MEASURE:MATH1:AVERAGE:
STATE 0;;MEASURE:MATH1:AVGFREQ:
STATE 0;;MEASURE:MATH1:AVGPERIOD:
STATE 0;;MEASURE:MATH1:BWIDTh1:
STATE 0;;MEASURE:MATH1:BWIDTh2:
STATE 0;;MEASURE:MATH1:DUTYCYCLE:
STATE 0;;MEASURE:MATH1:FALL:
STATE 0;;MEASURE:MATH1:FREQUENCY:
STATE 0;;MEASURE:MATH1:HIGh:
STATE 0;;MEASURE:MATH1:LOW:
STATE 0;;MEASURE:MATH1:MAXIMUM:
STATE 0;;MEASURE:MATH1:MINIMUM:
STATE 0;;MEASURE:MATH1:NOVERSHOOT:
STATE 0;;MEASURE:MATH1:NWIDTh:
STATE 0;;MEASURE:MATH1:PERIOD:
STATE 0;;MEASURE:MATH1:PNUMBER:
STATE 0;;MEASURE:MATH1:POVERSHOOT:
STATE 0;;MEASURE:MATH1:PTOPEAK:
STATE 0;;MEASURE:MATH1:PWIDTh:
STATE 0;;MEASURE:MATH1:RISE:
STATE 0;;MEASURE:MATH1:RMS:
STATE 0;;MEASURE:MATH1:SDEVIATION:
STATE 0;;MEASURE:MATH1:TY1INTEG:
STATE 0;;MEASURE:MATH1:TY2INTEG:
STATE 0;;MEASURE:MATH1:XY1INTEG:
STATE 0;;MEASURE:MATH1:XY2INTEG:
STATE 0;;MEASURE:MATH1:DELAY:
STATE OFF;MEASURE:SLOPE RISE;
COUNT 1;;MEASURE:MATH1:DELAY:
REFERENCE:SOURCE TRACE;TRACE MATH1;
SLOPE RISE;COUNT 1;;MEASURE:MATH1:
DPROXIMAL:MODE PERCENT;
PERCENT 10.0,50.0,90.0;
UNIT -3.00,0.00,3.00;;MEASURE:
MATH1:METHOD AUTO;;MEASURE:MATH2:
AVERAGE:STATE 0;;MEASURE:MATH2:
AVGFREQ:STATE 0;;MEASURE:MATH2:
AVGPERIOD:STATE 0;;MEASURE:MATH2:
BWIDTh1:STATE 0;;MEASURE:MATH2:
BWIDTh2:STATE 0;;MEASURE:MATH2:
DUTYCYCLE:STATE 0;;MEASURE:MATH2:
FALL:STATE 0;;MEASURE:MATH2:
FREQUENCY:STATE 0;;MEASURE:MATH2:
HIGh:STATE 0;;MEASURE:MATH2:LOW:
STATE 0;;MEASURE:MATH2:MAXIMUM:
STATE 0;;MEASURE:MATH2:MINIMUM:
STATE 0;;MEASURE:MATH2:NOVERSHOOT:
STATE 0;;MEASURE:MATH2:NWIDTh:
STATE 0;;MEASURE:MATH2:PERIOD:
STATE 0;;MEASURE:MATH2:PNUMBER:
STATE 0;;MEASURE:MATH2:POVERSHOOT:

```

```

STATE 0;;MEASURE:MATH2:PTOPEAK:
STATE 0;;MEASURE:MATH2:PWIDTh:
STATE 0;;MEASURE:MATH2:RISE:
STATE 0;;MEASURE:MATH2:RMS:
STATE 0;;MEASURE:MATH2:SDEVIATION:
STATE 0;;MEASURE:MATH2:TY1INTEG:
STATE 0;;MEASURE:MATH2:TY2INTEG:
STATE 0;;MEASURE:MATH2:XY1INTEG:
STATE 0;;MEASURE:MATH2:XY2INTEG:
STATE 0;;MEASURE:MATH2:DELAY:
STATE OFF;MEASURE:SLOPE RISE;
COUNT 1;;MEASURE:MATH2:DELAY:
REFERENCE:SOURCE TRACE;TRACE MATH2;
SLOPE RISE;COUNT 1;;MEASURE:MATH2:
DPROXIMAL:MODE PERCENT;
PERCENT 10.0,50.0,90.0;
UNIT -3.00,0.00,3.00;;MEASURE:
MATH2:METHOD AUTO;;MEASURE:USER1:
STATE 0;AREA1:TRACE 1;
ITEM PTOPEAK;;MEASURE:USER1:AREA2:
TRACE 2;ITEM MAXIMUM;;MEASURE:
USER1:OPERATION PLUS;UNIT "";;
MEASURE:USER2:STATE 0;AREA1:
TRACE 3;ITEM MINIMUM;;MEASURE:
USER2:AREA2:TRACE 4;ITEM RMS;;
MEASURE:USER2:OPERATION MINUS;
UNIT "";;MEASURE:USER3:STATE 0;
AREA1:TRACE MATH1;ITEM PERIOD;;
MEASURE:USER3:AREA2:TRACE MATH2;
ITEM AVGPERIOD;;MEASURE:USER3:
OPERATION MULTIPLE;UNIT "";;
MEASURE:USER4:STATE 0;AREA1:
TRACE NONE;ITEM XY1INTEG;;MEASURE:
USER4:AREA2:TRACE CONST1;
ITEM XY2INTEG;;MEASURE:USER4:
OPERATION DIVISION;UNIT "";;
MEASURE:CONST1 1.00000E+00;
CONST2 1.00000E+00;
CONST3 1.00000E+00;
CONST4 1.00000E+00;CYCLE:TRACE 1;;
MEASURE:ONECYCLE 0;TLINKAGE1 0;
TLINKAGE2 0;
TRANGE1 -5.0000000,5.0000000;
TRANGE2 -5.0000000,5.0000000

```

:MEASure:AMODE

Function	Sets whether to perform the automated measurement of waveform parameters on a normal single area (NORMal) or dual areas (AREA2) or queries the current setting.
Syntax	:MEASure:AMode {NORMal AREA2} :MEASure:AMode?
Example	:MEASURE:AMODE AREA2;MEASURE:AMODE? -> :MEASURE:AMODE AREA2

:MEASure: {CHANnel<x> | MATH<x>}?

Function Queries all specified parameter ON/OFF settings.

Syntax **:MEASure: {CHANnel<x> | MATH<x>}?**
 <x> of CHANnel <x>=1 to 4 (1 to 2 on the DL1720E)
 <x> of MATH <x>=1 or 2 (1 on the DL1720E)

Example (An example for CH1 is given below.)
:MEASure: CHANNEL1? -> :MEASure: CHANNEL1: AVERAGE: STATE 0; :MEASure: CHANNEL1: AVGFREQ: STATE 0; :MEASure: CHANNEL1: AVGPERIOD: STATE 0; :MEASure: CHANNEL1: BWIDTH1: STATE 0; :MEASure: CHANNEL1: BWIDTH2: STATE 0; :MEASure: CHANNEL1: DUTYCYCLE: STATE 0; :MEASure: CHANNEL1: FALL: STATE 0; :MEASure: CHANNEL1: FREQUENCY: STATE 0; :MEASure: CHANNEL1: HIGH: STATE 0; :MEASure: CHANNEL1: LOW: STATE 0; :MEASure: CHANNEL1: MAXIMUM: STATE 0; :MEASure: CHANNEL1: MINIMUM: STATE 0; :MEASure: CHANNEL1: NOVERSHOOT: STATE 0; :MEASure: CHANNEL1: NWIDTH: STATE 0; :MEASure: CHANNEL1: PERIOD: STATE 0; :MEASure: CHANNEL1: PNUMBER: STATE 0; :MEASure: CHANNEL1: POVERSHOOT: STATE 0; :MEASure: CHANNEL1: PTOPEAK: STATE 0; :MEASure: CHANNEL1: PWIDTH: STATE 0; :MEASure: CHANNEL1: RISE: STATE 0; :MEASure: CHANNEL1: RMS: STATE 0; :MEASure: CHANNEL1: SDEVIATION: STATE 0; :MEASure: CHANNEL1: TY1INTEG: STATE 0; :MEASure: CHANNEL1: TY2INTEG: STATE 0; :MEASure: CHANNEL1: XY1INTEG: STATE 0; :MEASure: CHANNEL1: XY2INTEG: STATE 0; :MEASure: CHANNEL1: DELAY: STATE 0; :MEASure: SLOPE RISE; COUNT 1; :MEASure: CHANNEL1: DELAY: REFERENCE: TRACE 1; SLOPE RISE; COUNT 1; :MEASure: CHANNEL1: DPROXIMAL: MODE PERCENT; PERCENT 10.0, 50.0, 90.0; UNIT -150.000E+00, 0.0E+00, 150.000E+00; :MEASure: CHANNEL1: METHOD AUTO 0

:MEASure: {CHANnel<x> | MATH<x>} : ALL

Function Turns all the automated measurement parameters of the waveform ON/OFF at once.

Syntax **:MEASure: {CHANnel<x> | MATH<x>} : ALL {<Boolean>}**
 <x> of CHANnel <x>=1 to 4 (1 to 2 on the DL1720E)
 <x> of MATH <x>=1 or 2 (1 on the DL1720E)

Example (The following example is for CH1.)
:MEASure: CHANNEL1: ALL OFF

:MEASure: {CHANnel<x> | MATH<x>} : COPY

Function Copies the ON/OFF state of all measurement parameters of one waveform to all other waveforms.

Syntax **:MEASure: {CHANnel<x> | MATH<x>} : COPY**
 <x> of CHANnel <x>=1 to 4 (1 to 2 on the DL1720E)
 <x> of MATH <x>=1 or 2 (1 on the DL1720E)

Example **:MEASure: CHANNEL1: COPY**

:MEASure: {CHANnel<x> | MATH<x>} : DELAY?

Function Queries all settings related to the delay between waveform waveforms.

Syntax **:MEASure: {CHANnel<x> | MATH<x>} : DELAY?**
 <x> of CHANnel <x>=1 to 4 (1 to 2 on the DL1720E)
 <x> of MATH <x>=1 or 2 (1 on the DL1720E)

Example **:MEASure: CHANNEL1: DELAY? -> :MEASure: CHANNEL1: DELAY: STATE 0; :MEASure: SLOPE RISE; COUNT 1; :MEASure: CHANNEL1: DELAY: REFERENCE: TRACE 1; SLOPE RISE; COUNT 1**

:MEASure: {CHANnel<x> | MATH<x>} : DELAY: MEASure?

Function Queries all settings related to the measured waveform when measuring the delay between waveforms.

Syntax **:MEASure: {CHANnel<x> | MATH<x>} : DELAY: MEASure?**
 <x> of CHANnel <x>=1 to 4 (1 to 2 on the DL1720E)
 <x> of MATH <x>=1 or 2 (1 on the DL1720E)

Example **:MEASure: CHANNEL1: DELAY: MEASure? -> :MEASure: CHANNEL1: MEASure: SLOPE RISE; COUNT 1**

:MEASure: {CHANnel<x> | MATH<x>} : DELAY: MEASure: COUNT

Function Sets the edge detection count of the measured waveform in the delay measurement between waveforms or queries the current setting.

Syntax **:MEASure: {CHANnel<x> | MATH<x>} : DELAY: MEASure: COUNT {<Nrf>}**
:MEASure: {CHANnel<x> | MATH<x>} : DELAY: MEASure: COUNT?
 <x> of CHANnel <x>=1 to 4 (1 to 2 on the DL1720E)
 <x> of MATH <x>=1 or 2 (1 on the DL1720E)

Example **:MEASure: CHANNEL1: DELAY: MEASure: COUNT 2**
:MEASure: CHANNEL1: DELAY: MEASure: COUNT? -> :MEASure: CHANNEL1: DELAY: MEASure: COUNT 2

:MEASure: {CHANnel<x> | MATH<x>} : DELAY: MEASure: SLOPe

Function Sets the slope of the measured waveform when measuring the delay between waveforms or queries the current setting.

Syntax **:MEASure: {CHANnel<x> | MATH<x>} : DELAY: MEASure: SLOPe {RISE | FALL}**
:MEASure: {CHANnel<x> | MATH<x>} : DELAY: MEASure: SLOPe?
 <x> of CHANnel <x>=1 to 4 (1 to 2 on the DL1720E)
 <x> of MATH <x>=1 or 2 (1 on the DL1720E)

Example **:MEASure: CHANNEL1: DELAY: MEASure: SLOPE RISE**
:MEASure: CHANNEL1: DELAY: MEASure: SLOPE? -> :MEASure: CHANNEL1: DELAY: MEASure: SLOPE RISE

5.17 MEASure Group

:MEASure: {CHANNEL<x> | MATH<x>} : DELAY : REFERENCE?

Function Queries all settings related to the reference waveform when measuring the delay between waveforms.

Syntax :MEASure: {CHANNEL<x> | MATH<x>} : DELAY:REFERENCE?
<x> of CHANNEL <x>=1 to 4 (1 to 2 on the DL1720E)

Example <x> of MATH <x>=1 or 2 (1 on the DL1720E)
:MEASURE:CHANNEL1:DELAY:REFERENCE?
-> :MEASURE:CHANNEL1:DELAY:REFERENCE:TRACE 1;SLOPE RISE;COUNT 1

:MEASure: {CHANNEL<x> | MATH<x>} : DELAY : REFERENCE:COUNT

Function Sets the edge detection count of the reference waveform in the delay measurement between waveforms or queries the current setting.

Syntax :MEASure: {CHANNEL<x> | MATH<x>} : DELAY:REFERENCE:COUNT {<NRf>}
:MEASure: {CHANNEL<x> | MATH<x>} : DELAY:REFERENCE:COUNT?
<x> of CHANNEL <x>=1 to 4 (1 to 2 on the DL1720E)

<x> of MATH <x>=1 or 2 (1 on the DL1720E)
<NRf>=1 to 9
Example :MEASURE:TRACE1:DELAY:REFERENCE:COUNT 2
:MEASURE:TRACE1:DELAY:REFERENCE:COUNT? -> :MEASURE:TRACE1:DELAY:REFERENCE:COUNT 2

:MEASure: {CHANNEL<x> | MATH<x>} : DELAY : REFERENCE:SLOPE

Function Sets the slope of the reference waveform when measuring the delay between waveforms or queries the current setting.

Syntax :MEASure: {CHANNEL<x> | MATH<x>} : DELAY:REFERENCE:SLOPE {RISE|FALL}
:MEASure: {CHANNEL<x> | MATH<x>} : DELAY:REFERENCE:SLOPE?
<x> of CHANNEL <x>=1 to 4 (1 to 2 on the DL1720E)

<x> of MATH <x>=1 or 2 (1 on the DL1720E)
Example :MEASURE:CHANNEL1:DELAY:REFERENCE:SLOPE RISE
:MEASURE:CHANNEL1:DELAY:REFERENCE:SLOPE? -> :MEASURE:CHANNEL1:DELAY:REFERENCE:SLOPE RISE

:MEASure: {CHANNEL<x> | MATH<x>} : DELAY : REFERENCE:SOURCE

Function Sets the reference of the delay measurement between waveforms to the trigger point or the waveform or queries the current setting.

Syntax :MEASure: {CHANNEL<x> | MATH<x>} : DELAY:REFERENCE:SOURCE {TRACE|TRIGGER}
:MEASure: {CHANNEL<x> | MATH<x>} : DELAY:REFERENCE:SOURCE?

<x> of CHANNEL <x>=1 to 4 (1 to 2 on the DL1720E)
<x> of MATH <x>=1 or 2 (1 on the DL1720E)
Example :MEASURE:CHANNEL1:DELAY:REFERENCE:SOURCE TRACE
:MEASURE:CHANNEL1:DELAY:REFERENCE:SOURCE? -> :MEASURE:CHANNEL1:DELAY:REFERENCE:SOURCE TRACE

:MEASure: {CHANNEL<x> | MATH<x>} : DELAY : REFERENCE:TRACE

Function Sets the trace of the reference waveform in the delay measurement between waveforms or queries the current setting.

Syntax :MEASure: {CHANNEL<x> | MATH<x>} : DELAY:REFERENCE:TRACE {<NRf> | MATH<x>}
:MEASure: {CHANNEL<x> | MATH<x>} : DELAY:REFERENCE:TRACE?

<x> of CHANNEL <x>=1 to 4 (1 to 2 on the DL1720E)
<x> of MATH <x>=1 or 2 (1 on the DL1720E)
<NRf>=1 to 4 (1 to 2 on the DL1720E)
Example :MEASURE:CHANNEL1:DELAY:REFERENCE:TRACE 2
:MEASURE:CHANNEL1:DELAY:REFERENCE:TRACE? -> :MEASURE:CHANNEL1:DELAY:REFERENCE:TRACE 2

:MEASure: {CHANNEL<x> | MATH<x>} : DELAY : STATE

Function Sets the measurement mode of the delay measurement between waveforms or queries the current setting.

Syntax :MEASure: {CHANNEL<x> | MATH<x>} : DELAY:STATE {OFF|ON|DEGREE}
:MEASure: {CHANNEL<x> | MATH<x>} : DELAY:STATE?

<x> of CHANNEL <x>=1 to 4 (1 to 2 on the DL1720E)
<x> of MATH <x>=1 or 2 (1 on the DL1720E)
Example :MEASURE:CHANNEL1:DELAY:STATE ON
:MEASURE:CHANNEL1:DEALY:STATE? -> :MEASURE:CHANNEL1:DELAY:STATE ON

**:MEASure:{CHANnel<x>|MATH<x>}:
DPRoximal?**

Function Queries all settings related to distal, mesial, and proximal values of the automated measurement of waveform parameters.

Syntax MEASure:{CHANnel<x>|MATH<x>}:
DPRoximal?
<x> of CHANnel <x>=1 to 4 (1 to 2 on the
DL1720E)
<x> of MATH <x>=1 or 2 (1 on the DL1720E)

Example :MEASURE:CHANNEL1:DPROXIMAL? ->
:MEASURE:CHANNEL1:DPROXIMAL:
MODE PERCENT;
PERCENT 10.0,50.0,90.0;
UNIT -2.000E+00,0.0E+00,2.000E+00

**:MEASure:{CHANnel<x>|MATH<x>}:
DPRoximal:MODE**

Function Sets the unit of the distal, mesial, and proximal values of the automated measurement of waveform parameters or queries the current setting.

Syntax :MEASure:{CHANnel<x>|MATH<x>}:
DPRoximal:MODE {PERCent|UNIT}
:MEASure:{CHANnel<x>|MATH<x>}:
DPRoximal:MODE?
<x> of CHANnel <x>=1 to 4 (1 to 2 on the
DL1720E)
<x> of MATH <x>=1 or 2 (1 on the DL1720E)

Example :MEASURE:CHANNEL1:DPROXIMAL:
MODE PERCENT
:MEASURE:CHANNEL1:DPROXIMAL:MODE?
-> :MEASURE:CHANNEL1:DPROXIMAL:
MODE PERCENT

**:MEASure:{CHANnel<x>|MATH<x>}:
DPRoximal:PERCent**

Function Sets the distal, mesial, and proximal values of the automated measurement of waveform parameters in terms of a percentage or queries the current setting.

Syntax :MEASure:{CHANnel<x>|MATH<x>}:
DPRoximal:PERCent {<NRf>,<Nrf>,
<Nrf>}
:MEASure:{CHANnel<x>|MATH<x>}:
DPRoximal:PERCent?
<x> of CHANnel <x>=1 to 4 (1 to 2 on the
DL1720E)
<x> of MATH <x>=1 or 2 (1 on the DL1720E)

Example :MEASURE:CHANNEL1:DPROXIMAL:
PERCENT 80,60,40
:MEASURE:CHANNEL1:DPROXIMAL:
PERCENT? -> :MEASURE:CHANNEL1:
DPROXIMAL:PERCENT 80,60,40

**:MEASure:{CHANnel<x>|MATH<x>}:
DPRoximal:UNIT**

Function Sets the distal, mesial, and proximal values of the automated measurement of waveform parameters in terms of a voltage or current or queries the current setting.

Syntax :MEASure:{CHANnel<x>|MATH<x>}:
DPRoximal:UNIT {<voltage>,
<voltage>,<voltage>|<NRf>,<Nrf>,
<Nrf>}
:MEASure:{CHANnel<x>|MATH<x>}:
DPRoximal:UNIT?
<x> of CHANnel <x>=1 to 4 (1 to 2 on the
DL1720E)
<x> of MATH <x>=1 or 2 (1 on the DL1720E)
<voltage>=8 div on the screen (0.01 div steps)
<Nrf>=-4 to 4 div (0.01 div steps)

Example :MEASURE:CHANNEL1:DPROXIMAL:
UNIT 50V,0V,-50V
:MEASURE:CHANNEL1:DPROXIMAL:UNIT?
-> :MEASURE:CHANNEL1:DPROXIMAL:
UNIT 50.0E+00,0.0E+00,-50.0E+00

Description When set to the current probe, sets the
<Current> value or queries the current setting.

:MEASure:{CHANnel<x>|MATH<x>}:METHOD

Function Sets the high and low levels of the automated measurement of waveform parameters or queries the current setting.

Syntax :MEASure:{CHANnel<x>|MATH<x>}:
METHod {AUTO|MAXMin}
:MEASure:{CHANnel<x>|MATH<x>}:
METHod?
<x> of CHANnel <x>=1 to 4 (1 to 2 on the
DL1720E)
<x> of MATH <x>=1 or 2 (1 on the DL1720E)

Example :MEASURE:CHANNEL1:METHOD AUTO
:MEASURE:CHANNEL1:METHOD? ->
:MEASURE:CHANNEL1:METHOD AUTO

**:MEASure:{CHANnel<x>|MATH<x>}:
<Parameter> ?**

Function Queries the settings related to the waveform parameter of the waveform.

Syntax :MEASure:{CHANnel<x>|MATH<x>}:
<Parameter>?
<x> of CHANnel <x>=1 to 4 (1 to 2 on the
DL1720E)
<x> of MATH <x>=1 or 2 (1 on the DL1720E)
<Parameter>= {AVERAGE|AVGFreq|
AVGPeriod|BWIDTH1|BWIDTH2|DUTYcycle|
FALL|FREQUENCY|HIGH|LOW|MAXimum|
MINimum|NOVershoot|NWIDTH|PERIOD|
PNUMBER|POVershoot|PTOPeak|
PWIDTh|RISE|RMS|SDEVIation|TY1Integ|
TY2Integ|XY1Integ|XY2Integ}

Example (The following is an example for the average
value of CH1.)
:MEASURE:CHANNEL1:AVERAGE? ->
:MEASURE:CHANNEL1:AVERAGE:STATE 1

5.17 MEASure Group

**:MEASure: {CHANnel<x> | MATH<x>} :
<Parameter>: COUNT?**

Function Queries the statistical processing count of the waveform parameter.

Syntax **:MEASure: {CHANnel<x> | MATH<x>} :
<Parameter>: COUNT?**
 <x> of CHANnel <x>=1 to 4 (1 to 2 on the DL1720E)
 <x> of MATH <x>=1 or 2 (1 on the DL1720E)
 <Parameter>={AVERAge | AVGFreq | AVGPeriod | BWIDth1 | BWIDth2 | DELay | DUTYcycle | FALL | FREQuency | HIGH | LOW | MAXimum | MINimum | NOVershoot | NWIDth | PERiod | PNUMber | POVershoot | PTOPeak | PWIDth | RISE | RMS | SDEVIation | TY1Integ | TY2Integ | XY1Integ | XY2Integ}

Example (The following is an example for the average value of CH1.)
:MEASURE: CHANNEL1: AVERAGE: COUNT?
-> :MEASURE: CHANNEL1: AVERAGE: COUNT 100

**:MEASure: {CHANnel<x> | MATH<x>} :
<Parameter>: {MAXimum | MEAN | MINimum | SDEVIation}?**

Function Queries the statistical value of the waveform parameter.

Syntax **:MEASure: {CHANnel<x> | MATH<x>} :
<Parameter>: {MAXimum | MEAN | MINimum | SDEVIation}?**
 <x> of CHANnel <x>=1 to 4 (1 to 2 on the DL1720E)
 <x> of MATH <x>=1 or 2 (1 on the DL1720E)
 <Parameter>={AVERAge | AVGFreq | AVGPeriod | BWIDth1 | BWIDth2 | DELay | DUTYcycle | FALL | FREQuency | HIGH | LOW | MAXimum | MINimum | NOVershoot | NWIDth | PERiod | PNUMber | POVershoot | PTOPeak | PWIDth | RISE | RMS | SDEVIation | TY1Integ | TY2Integ | XY1Integ | XY2Integ}

Example (The following is an example for the maximum value.)
:MEASURE: CHANNEL1: AVERAGE: MAXIMUM? -> :MEASURE: CHANNEL1: AVERAGE: MAXIMUM -40.0000E-06

Description If the statistics cannot be found, "NAN(Not A Number)" is returned.

**:MEASure: {CHANnel<x> | MATH<x>} :
<Parameter>: STATE**

Function Turns ON/OFF the waveform parameter one by one or queries the current setting.

Syntax **:MEASure: {CHANnel<x> | MATH<x>} :
<Parameter>: STATE {<Boolean>}**
**:MEASure: {CHANnel<x> | MATH<x>} :
<Parameter>: STATE?**
 <x> of CHANnel <x>=1 to 4 (1 to 2 on the DL1720E)
 <x> of MATH <x>=1 or 2 (1 on the DL1720E)
 <Parameter>={AVERAge | AVGFreq | AVGPeriod | BWIDth1 | BWIDth2 | DUTYcycle | FALL | FREQuency | HIGH | LOW | MAXimum | MINimum | NOVershoot | NWIDth | PERiod | PNUMber | POVershoot | PTOPeak | PWIDth | RISE | RMS | SDEVIation | TY1Integ | TY2Integ | XY1Integ | XY2Integ}

Example (The following is an example for the average value of CH1.)
:MEASURE: CHANNEL1: AVERAGE: STATE ON
:MEASURE: CHANNEL1: AVERAGE: STATE? -> :MEASURE: CHANNEL1: AVERAGE: STATE 1

**:MEASure: {CHANnel<x> | MATH<x>} :
<Parameter>: VALUE?**

Function Queries the automated measurement value of the waveform parameter.

Syntax **:MEASure: {CHANnel<x> | MATH<x>} :
<Parameter>: VALUE? [{NRf}]**
 <x> of CHANnel <x>=1 to 4 (1 to 2 on the DL1720E)
 <x> of MATH <x>=1 or 2 (1 on the DL1720E)
 <Parameter>={AVERAge | AVGFreq | AVGPeriod | BWIDth1 | BWIDth2 | DELay | DUTYcycle | FALL | FREQuency | HIGH | LOW | MAXimum | MINimum | NOVershoot | NWIDth | PERiod | PNUMber | POVershoot | PTOPeak | PWIDth | RISE | RMS | SDEVIation | TY1Integ | TY2Integ | XY1Integ | XY2Integ}

Example (The following is an example for the average value of CH1.)
:MEASURE: CHANNEL1: AVERAGE: VALUE? -> :MEASURE: CHANNEL1: AVERAGE: VALUE 4.950E+00

Description If the measurement is not possible, "NAN (Not A Number)" is returned. The last <NRf> is used to query the parameter value of the <NRf> time after executing the statistical processing. If the value corresponding to the relevant count, "NAN (Not A Number)" is returned.

- **In the case other than cycle statistical processing**
 <NRf> can be omitted. If omitted, inquiry is made on the parameter value of the newest history. If <NRf> is attached, inquiry is made on parameter value of the <NRf>-th oldest waveform from the newest waveform in the history memory.
- **In the case of cycle statistical processing**
 <NRf> can be omitted. If omitted, inquiry is made on the parameter value in the range of the last measured cycle. If <NRf> is attached, inquiry is made in the range of the cycle measured on the <NRf>-th time from the left of the screen.

:MEASure:CONSt<x>

Function Sets the constants to be used in the automated measurement of waveform parameters of Dual Area or queries the current setting.

Syntax **:MEASure:CONSt<x>** {<NRf>}
:MEASure:CONSt<x>?
 <NRf>=-9.9999E+30 to 9.9999E+30
 <x>=1 to 4

Example **:MEASURE:CONST1 1.0000E+00**
:MEASURE:CONST1? ->
:MEASURE:CONST1 1.0000E+00

:MEASure:CYCLE?

Function Queries all settings related to the periodic statistical processing of the automated measurement of waveform parameters (Cycle Statistics).

Syntax **:MEASure:CYCLE?**

Example **:MEASURE:CYCLE? ->**
:MEASURE:CYCLE:TRACE 1

:MEASure:CYCLE:ABORT

Function Aborts the periodic statistical processing of the automated measurement of waveform parameters (Cycle Statistics).

Syntax **:MEASure:CYCLE:ABORT**

Example **:MEASURE:CYCLE:ABORT**

:MEASure:CYCLE:EXECute

Function Executes the periodic statistical processing of the automated measurement of waveform parameters (Cycle Statistics).

Syntax **:MEASure:CYCLE:EXECute**

Example **:MEASURE:CYCLE:EXECUTE**

:MEASure:CYCLE:TRACe

Function Sets the waveform used to determine the period for the periodic statistical processing of automated measurement of waveform parameters (Cycle Statistics) or queries the current setting.

Syntax **:MEASure:CYCLE:TRACe** {OWN|<NRf>}
 MATH<x>}
:MEASure:CYCLE:TRACe?
 <NRf>=1 to 4 (1 to 2 on the DL1720E)
 <x>=1 or 2 (1 on the DL1720E)

Example **:MEASURE:CYCLE:TRACE 1**
:MEASURE:CYCLE:TRACE? ->
:MEASURE:CYCLE:TRACE 1

:MEASure:HISTory:ABORT

Function Aborts the statistical processing within the historical data of the automated measurement of waveform parameters (History Statistics).

Syntax **:MEASure:HISTory:ABORT**

Example **:MEASURE:HISTORY:ABORT**

:MEASure:HISTory:EXECute

Function Executes the statistical processing within the historical data of the automated measurement of waveform parameters (History Statistics).

Syntax **:MEASure:HISTory:EXECute**

Example **:MEASURE:HISTORY:EXECUTE**

:MEASure:MODE

Function Sets the mode of the automated measurement of waveform parameters or queries the current setting.

Syntax **:MEASure:MODE** {OFF|ON|STATISTICS|
 CYCLE|HISTORY}
:MEASure:MODE?

Example **:MEASURE:MODE ON**
:MEASURE:MODE? -> :MEASURE:MODE ON

:MEASure:ONECycle

Function Turns ON/OFF the automated measurement in the one-cycle mode or queries the current setting.

Syntax **:MEASure:ONECycle** {<Boolean>}
:MEASure:ONECycle?

Example **:MEASURE:ONECYCLE ON**
:MEASURE:ONECYCLE ->
:MEASURE:ONECYCLE 1

:MEASure:TLINKage<x>

Function Turns ON/OFF the linked movement of the cursors in the automated measurement of waveform parameters or queries the current setting.

Syntax **:MEASure:TLINKage<x>** {<Boolean>}
:MEASure:TLINKage<x>?
 <x>=1, 2

Example **:MEASURE:TLINKAGE1 ON**
:MEASURE:TLINKAGE1 ->
:MEASURE:TLINKAGE1 1

Description “:MEASURE:TLINKAGE1” sets the links for T-Range1 and T-Range2 or queries the current settings. “:MEASURE:TLINKAGE2” sets the links for T-Range3 and T-Range4 or queries the current settings.

:MEASure:TRANge<x> (Time Range)

Function Sets the measurement range of the automated measurement of waveform parameters or queries the current setting.

Syntax **:MEASure:TRANge<x>** {<NRf>,<NRf>}
:MEASure:TRANge<x>?
 <x>=1, 2
 <NRf>=-5 to 5 div (10 div/displayed record length steps)

Example **:MEASURE:TRANGE1 -4,4**
:MEASURE:TRANGE1? ->
:MEASURE:TRANGE1 -4.00E+00,4.00E+00

Description “:Measure:TRANGE1” sets the measurement range of Area1 during normal measurement and during measurement on dual areas or queries the current setting. “:Measure:TRANGE2” sets the measurement range of Area2 during the measurement on dual areas or queries the current setting.

5.17 MEASure Group

:MEASure:USER<x>?

Function Queries all settings related to the automated measurement of waveform parameters of the Dual Area.

Syntax `:MEASure:USER<x>?`
`<x>=1 to 4`

Example `:MEASURE:USER1? -> :MEASURE:USER1:
AREA1:TRACE 1;ITEM PTOPEAK;;
MEASURE:USER1:AREA2:TRACE 2;
ITEM MAXIMUM;;MEASURE:USER2:AREA1:
TRACE 3;ITEM MINIMUM;;MEASURE:
USER2:AREA2:TRACE 4;ITEM RMS;;
MEASURE:USER3:AREA1:TRACE MATH1;
ITEM PERIOD;;MEASURE:USER3:AREA2:
TRACE MATH2;ITEM AVGPERIOD;;
MEASURE:USER4:AREA1:TRACE CONST1;
ITEM TY1INTEG;MEASURE:USER4:
AREA2:TRACE NONE;ITEM XY2INTEG`

:MEASure:USER<x>:AREA<y>?

Function Queries all settings related to the specified computation parameter/area of the automated measurement of waveform parameters of the Dual Area.

Syntax `:MEASure:USER<x>:AREA<y>?`
`<x>=1 to 4`
`<y>=1, 2`

Example `:MEASURE:USER1:AREA1? ->
:MEASURE:USER1:AREA1:TRACE 1;
ITEM PTOPEAK`

:MEASure:USER<x>:AREA<y>:ITEM

Function Sets the measurement item of the specified computation parameter/area of the automated measurement of waveform parameters of the Dual Area or queries the current setting.

Syntax `:MEASure:USER<x>:AREA<y>:
ITEM {<Parameter>}`
`:MEASure:USER<x>:AREA<y>:ITEM?`
`<x>=1 to 4`
`<y>=1, 2`
`<Parameter>={AVERage|AVGFreq|
AVGPeriod|BWIDth1|BWIDth2|DUTYcycle|
FALL|FREQuency|HIGH|LOW|MAXimum|
MINimum|NOVershoot|NWIDTH|PERiod|
PNUmber|POVershoot|PTOPeak|PWIDth|
RISE|RMS|SDEViation|TY1Integ|TY2Integ|
XY1Integ|XY2Integ}`

Example `:MEASURE:USER1:AREA1:ITEM PTOPEAK
:MEASURE:USER1:AREA1:ITEM? ->
:MEASURE:USER1:AREA1:ITEM PTOPEAK`

:MEASure:USER<x>:AREA<y>:TRACe

Function Sets the measurement trace of the specified computation parameter/area of the automated measurement of waveform parameters of the Dual Area.

Syntax `:MEASure:USER<x>:AREA<y>:TRACe
{<NRf>|MATH<z>|NONE|CONSt<w>}`
`:MEASure:USER<x>:AREA<y>:TRACe?`
`<x>=1 to 4`
`<y>=1 or 2`
`<NRf>=1 to 4 (1 to 2 on the DL1720E)`
`<z>=1 or 2 (1 on the DL1720E)`
`<w>=1 to 4`

Example `:MEASURE:USER1:AREA1:TRACE 1
:MEASURE:USER1:AREA1:TRACE ->
:MEASURE:USER1:AREA1:TRACE 1`

:MEASure:USER<x>:COUNT?

Function Queries the statistical processing count of the automated measurement of waveform parameters of the Dual Area.

Syntax `:MEASure:USER<x>:COUNT?`
`<x>=1 to 4`

Example `:MEASURE:USER1:COUNT? ->
:MEASURE:USER1:COUNT 100`

:MEASure:USER<x>:{MAXimum|MEAN|MINimum|SDEViation}?

Function Queries the statistical value of the automated measurement of waveform parameters of the Dual Area.

Syntax `:MEASure:USER<x>:{MAXimum|MEAN|
MINimum|SDEViation}?`
`<x>=1 to 4`

Example (The following is an example for the maximum value.)
`:MEASURE:USER1:MAXIMUM? ->
:MEASURE:USER1:MAXIMUM 1.000E+00`

Description If the statistics cannot be determined, "NAN (Not A Number)" is returned.

:MEASure:USER<x>:OPERation

Function Sets the computing operation of the automated measurement of waveform parameters of the Dual Area or queries the current setting.

Syntax `:MEASure:USER<x>:OPERation {PLUS|
MINus|MULTiple|DIVision}`
`:MEASure:USER<x>:OPERation?`
`<x>=1 to 4`

Example `:MEASURE:USER1:OPERATION PLUS
:MEASURE:USER1:OPERATION ->
:MEASURE:USER1:OPERATION PLUS`

:MEASure:USER<x>:STATE

Function Turns ON/OFF the automated measurement of waveform parameters of the Dual Area or queries the current setting.

Syntax `:MEASure:USER<x>:STATE {<Boolean>}`
`:MEASure:USER<x>:STATE?`
`<x>=1 to 4`

Example `:MEASURE:USER1:STATE ON
:MEASURE:USER1:STATE ->
:MEASURE:USER1:STATE 1`

:MEASure:USER<x>:UNIT

Function Sets the display unit of the automated measurement of waveform parameters of the Dual Area or queries the current setting.

Syntax `:MEASure:USER<x>:UNIT <Character
string>`
`:MEASure:USER<x>:UNIT?`
`<x>=1 to 4`
`<Character string>=Up to 3 characters`

Example `:MEASURE:USER1:UNIT "UNIT"
:MEASURE:USER1:UNIT ->
:MEASURE:USER1:UNIT "UNIT"`

:MEASure:USER<x>:VALue?

Function	Queries the measured value of the automated measurement of waveform parameters of the Dual Area.
Syntax	:MEASure:USER<x>:VALue? [{<NRf>}] <x>=1 to 4 <NRf>=1 to 24000
Example	:MEASURE:USER1:VALUE? -> :MEASURE:USER1:VALUE 1.000E+00
Description	The last appended <NRf> is used to query each parameter of <NRf> numbers after statistical processing. When the value corresponding to a number does not exist, "NAN (Not A Number)" is returned. <NRf> can be omitted. If omitted, the newest parameter in history is queried. If <NRf> is appended, queries the parameters from the newest waveform in history memory to the <NRf> waveform.

:MEASure:WAIT?

Function	Waits for the completion of the automated measurement of waveform parameters with a timeout option.
Syntax	:MEASure:WAIT? {<NRf>} <NRf>=1 to 36000 (timeout period, 100 ms steps)
Example	:MEASURE:WAIT? 100 -> :MEASURE:WAIT 1
Description	<ul style="list-style-type: none"> Returns "0" if the automated measurement completes within the timeout period or "1" if it is not complete or automated measurement is not in progress. Even if the timeout period is sufficiently long, "0" is returned when the automated measurement completes.

5.18 PHASe Group

The commands in the PHASe group deal with the phase shift function. These commands can be used to make the same settings and inquiries as when SHIFT + MATH on the front panel is pressed.

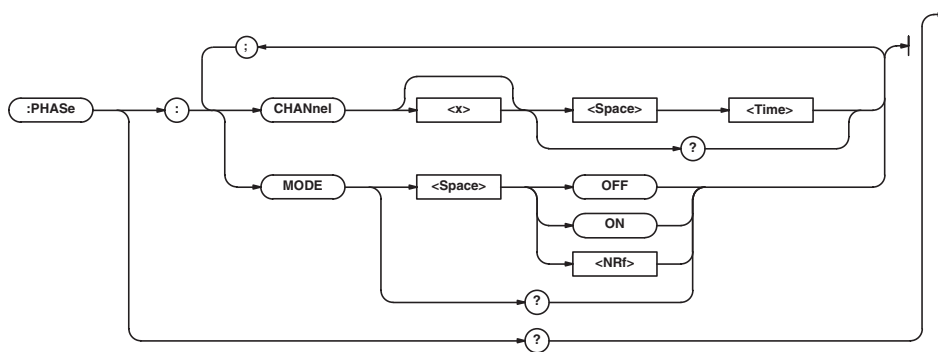

: PHASe?

Function Queries all settings related to the phase shift function.

Syntax :PHASe?

Example :PHASe? -> :PHASe:MODE 0;
 CHANNEL1 0.0E+00;CHANNEL2
 0.0E+00;CHANNEL3 0.0E+00;
 CHANNEL4 0.0E+00;CHANNEL5 0.0E+00;
 CHANNEL6 0.0E+00;CHANNEL7 0.0E+00;
 CHANNEL8 0.0E+00

: PHASe:CHANnel<x>

Function Sets the amount of phase shift of the waveform or queries the current setting.

Syntax :PHASe:CHANnel<x> {<time>}
 :PHASe:CHANnel<x>?
 <x>=1 to 4 (1 to 2 on the DL1720E)
 <time>=time between -T/div*5 and T/div*5

Example :PHASe:CHANNEL2 1us
 :PHASe:CHANNEL2? -> :PHASe:CHANNEL2
 1.000000E-06

Description

- Phase shift may not be possible on some channels depending on the interleave mode setting.
- When the time base is set to external clock, an error results.

: PHASe:MODE

Function Turns the phase shift function ON/OFF or queries the current setting.

Syntax :PHASe:MODE {<Boolean>}
 :PHASe:MODE?

Example :PHASe:MODE ON
 :PHASe:MODE? -> :PHASe:MODE 1

Description When the time base is set to external clock, an error results.

5.19 PRESet Group

The commands in the PRESet group deal with the preset function. These commands can be used to make the same settings and inquiries as when PRESET on the front panel is pressed.

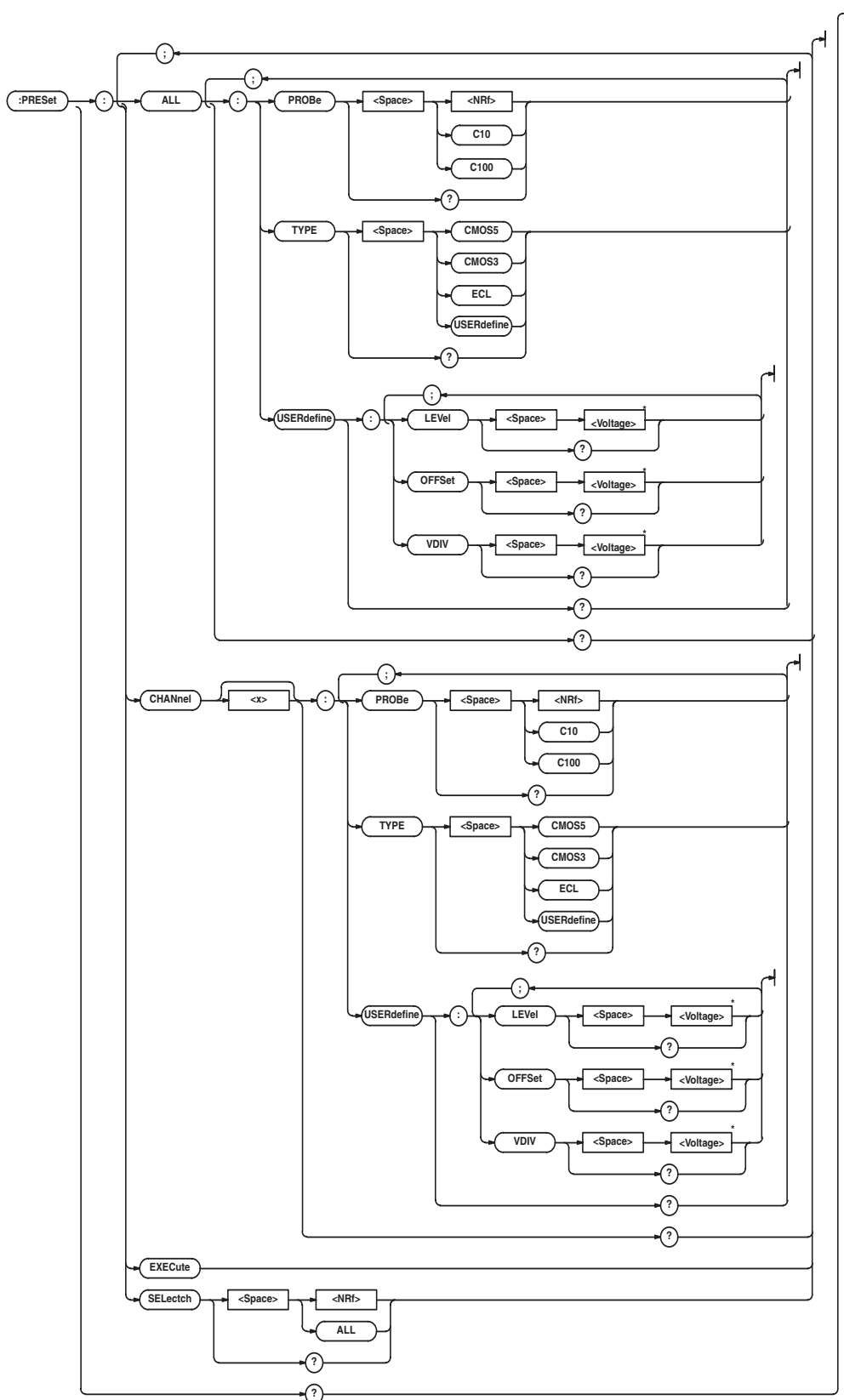

* When the target channel is set to the current probe, becomes <Current>.

5.19 PRESet Group

:PRESet?

Function Queries all settings related to the preset function.

Syntax :PRESet?

Example :PRESet -> :PRESET:ALL:TYPE CMOS5;
USERDEFINE:VDIV 2.000000E+00;
LEVEL 2.500000E+00;OFFSET 0.0E+00;;
PRESET:ALL:PROBE 10;;PRESET:
SELECTCH ALL;CHANNEL1:TYPE CMOS5;
USERDEFINE:VDIV 2.000000E+00;
LEVEL 2.500000E+00;OFFSET 0.0E+00;;
PRESET:CHANNEL1:PROBE 10;;PRESET:
CHANNEL2:TYPE CMOS5;USERDEFINE:
VDIV 2.000000E+00;
LEVEL 2.500000E+00;OFFSET 0.0E+00;;
PRESET:CHANNEL2:PROBE 10;;PRESET:
CHANNEL3:TYPE CMOS5;USERDEFINE:
VDIV 2.000000E+00;
LEVEL 2.500000E+00;OFFSET 0.0E+00;;
PRESET:CHANNEL3:PROBE 10;;PRESET:
CHANNEL4:TYPE CMOS5;USERDEFINE:
VDIV 2.000000E+00;
LEVEL 2.500000E+00;OFFSET 0.0E+00;;
PRESET:CHANNEL4:PROBE 10

:PRESet:ALL:PROBE

Function Sets the preset value of the probe attenuation/current-to-voltage conversion ratio of all channels.

Syntax :PRESet:ALL:PROBE {<Nrf>|C10|C100}
<Nrf>=1, 10, 100, 1000

Example :PRESET:ALL:PROBE 10

:PRESet:ALL:TYPE

Function Sets preset values to all channels.

Syntax :PRESet:ALL:TYPE {CMOS5|CMOS3|
ECL|USERdefine}

Example :PRESET:ALL:TYPE USERDEFINE

:PRESet:ALL:USERdefine:LEVEL

Function Sets the preset trigger level of all channels.

Syntax :PRESet:ALL:USERdefine:LEVEL
{<voltage>}
<voltage>=8 div on the screen (0.01 div steps)

Example :PRESET:ALL:USERDEFINE:LEVEL 0V

Description When set to the current probe, sets the <Current> value.

:PRESet:ALL:USERdefine:OFFSet

Function Sets the preset offset voltage of all channels.

Syntax :PRESet:ALL:USERdefine:OFFSet
{<voltage>}
<voltage>=See the User's Manual.

Example :PRESET:ALL:USERDEFINE:OFFSET 0V

Description When set to the current probe, sets the <Current> value.

:PRESet:ALL:USERdefine:VDIV

Function Sets the preset V/div value of all channels.

Syntax :PRESet:ALL:USERdefine:VDIV
{<voltage>}
<voltage>=2 mV to 10 V (when the probe
attenuation is 1:1, See the User's Manual.)

Example :PRESET:ALL:USERDEFINE:VDIV 2V

Description When set to the current probe, sets the <Current> value.

:PRESet:CHANnel<x>?

Function Queries the preset information of the specified channel.

Syntax :PRESet:CHANnel<x>?
<x>=1 to 4 (1 to 2 on the DL1720E)

Example :PRESET:CHANNEL1? ->
:PRESET:CHANNEL1:TYPE TTL;
USERDEFINE:VDIV 50.000E+00;
LEVEL 0.0E+00;OFFSET 0.0E+00;;
PRESET:CHANNEL1:PROBE 10

:PRESet:CHANnel<x>:PROBE

Function Sets the preset value of the probe attenuation/current-to-voltage conversion ratio of the specified channel or queries the current setting.

Syntax :PRESet:CHANnel<x>:PROBE {<Nrf>}
:PRESet:CHANnel<x>:PROBE?
<x>=1 to 4 (1 to 2 on the DL1720E)
<Nrf>=1, 10, 100, 1000

Example :PRESET:CHANNEL1:PROBE 1
:PRESET:CHANNEL1:PROBE? ->
:PRESET:CHANNEL1:PROBE 1

:PRESet:CHANnel<x>:TYPE

Function Sets the specified preset or queries the current setting

Syntax :PRESet:CHANnel<x>:TYPE
{ECL|TTL|ECL|USERdefine}
:PRESet:CHANnel<x>:TYPE?
<x>=1 to 4 (1 to 2 on the DL1720E)

Example :PRESET:CHANNEL1:TYPE USERDEFINE
:PRESET:CHANNEL1:TYPE? ->
:PRESET:CHANNEL1:TYPE USERDEFINE

:PRESet:CHANnel<x>:USERdefine?

Function Queries all preset values when using user-type presets.

Syntax :PRESet:CHANnel<x>:USERdefine?
<x>=1 to 4 (1 to 2 on the DL1720E)

Example :PRESET:CHANNEL1:USERDEFINE? ->
:PRESET:CHANNEL1:USERDEFINE:
VDIV 50.000E+00;LEVEL 0.0E+00;
OFFSET 0.0E+00

:PRESet:CHANnel<x>:USERdefine:LEVEL

Function Sets the preset value of the user-type trigger level or queries the current setting.

Syntax :PRESet:CHANnel<x>:USERdefine:LEVEL
{<voltage>}
:PRESet:CHANnel<x>:USERdefine:
LEVEL?
<x>=1 to 4 (1 to 2 on the DL1720E)
<voltage>=8 div on the screen (0.01 div steps)

Example :PRESET:CHANNEL1:USERDEFINE:
LEVEL 0V
:PRESET:CHANNEL1:USERDEFINE:
LEVEL? -> :PRESET:CHANNEL1:
USERDEFINE:LEVEL 0.000E+00

Description When set to the current probe, queries the <Current> value.

:PRESet:CHANnel<x>:USERdefine:OFFSet

Function Sets the preset value of the user-type offset voltage or queries the current setting.

Syntax :PRESet:CHANnel<x>:USERdefine:
OFFSet {<voltage>}
:PRESet:CHANnel<x>:USERdefine:
OFFSet?

<x>=1 to 4 (1 to 2 on the DL1720E)
<voltage>=See the User's Manual.

Example :PRESet:CHANnel1:USERDEFINE:
OFFSET 0V
:PRESet:CHANnel1:USERDEFINE:
OFFSET? -> :PRESet:CHANnel1:
USERDEFINE:OFFSET 0.000E+00

Description When set to the current probe, queries the <Current> value.

:PRESet:CHANnel<x>:USERdefine:VDIV

Function Sets the preset value of the user-type V/div value or queries the current setting.

Syntax :PRESet:CHANnel<x>:USERdefine:
VDIV {<voltage>}
:PRESet:CHANnel<x>:USERdefine:VDIV?
<x>=1 to 4 (1 to 2 on the DL1720E)
<voltage>=2 mV to 10 V (when the probe
attenuation is 1:1, See the User's Manual.)

Example :PRESet:CHANnel1:USERDEFINE:VDIV 2V
:PRESet:CHANnel1:USERDEFINE:VDIV?
-> :PRESet:CHANnel1:USERDEFINE:
VDIV 2.000E+00

Description When set to the current probe, queries the <Current> value.

:PRESet:EXECute

Function Executes preset.

Syntax :PRESet:EXECute

Example :PRESet:EXECUTE

Description Preset the channel which is selected by the
":PRESet:SElectch" command.

:PRESet:SElectch

Function Sets the channel to be preset or queries the current setting.

Syntax :PRESet:SElectch {ALL|<NRf>}
:PRESet:SElectch?
<NRf>=1 to 4 (1 to 2 on the DL1720E)

Example :PRESet:SElectch 1
:PRESet:SElectch? ->
:PRESet:SElectch 1

5.20 RECall Group

The commands in the RECall group are used to recall the setup data from the internal memory. These commands can be used to carry out the same operations as when SETUP on the front panel is pressed.



:RECall:SETUp<x>:EXECute

Function Recalls the setting parameters from the internal memory.

Syntax :RECall:SETUp<x>:EXECute
<x>=1 to 3

Example :RECALL:SETUP1:EXECute

Description If you specify an unsaved number, an error occurs.

5.21 SEARCh Group

The commands in the SEARCh group are used to search & zoom function. These commands can be used to carry out the same operations or to make the same settings and inquiries as when SHIFT + ZOOM on the front panel is pressed.

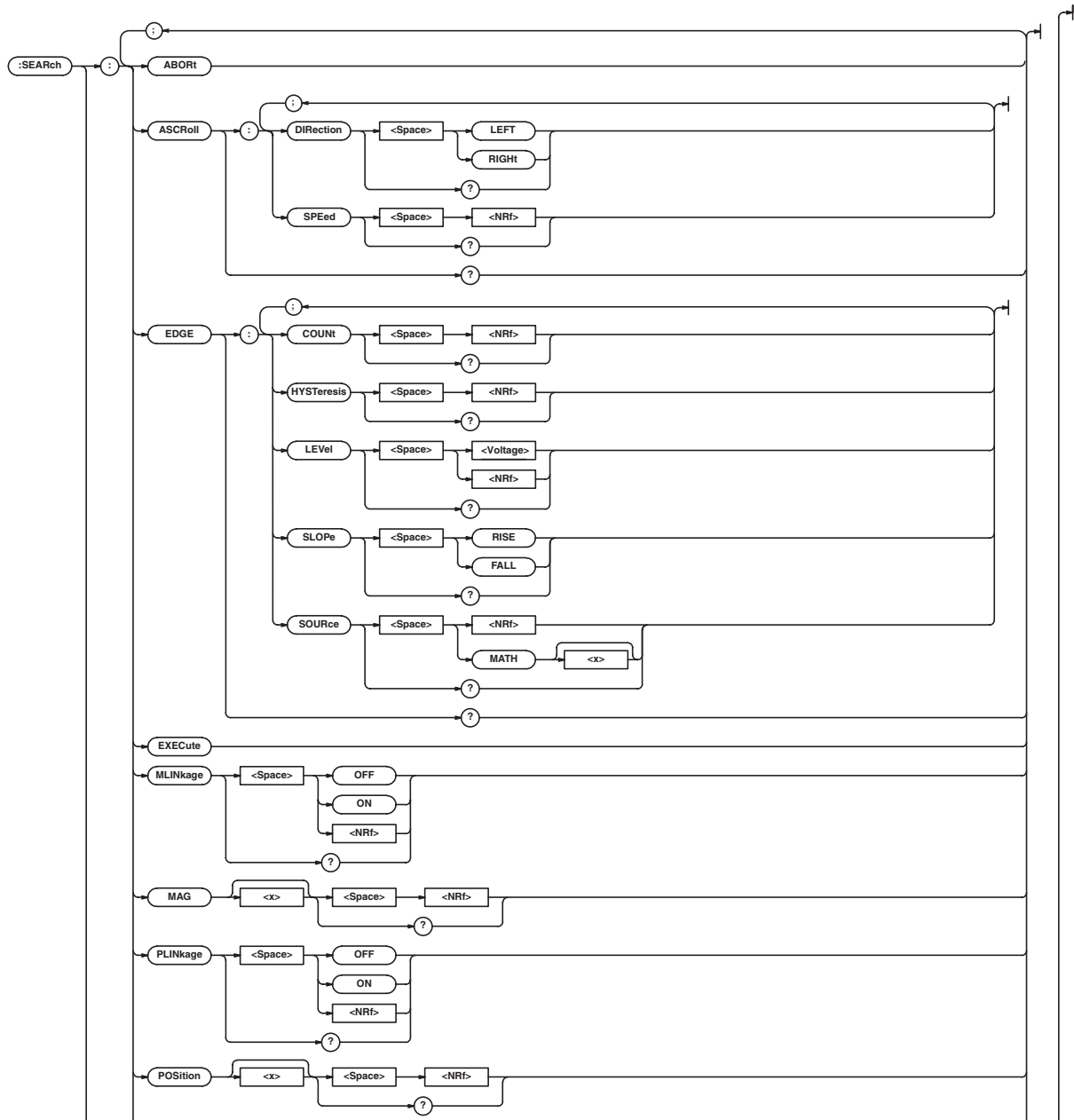

5.21 SEARCh Group

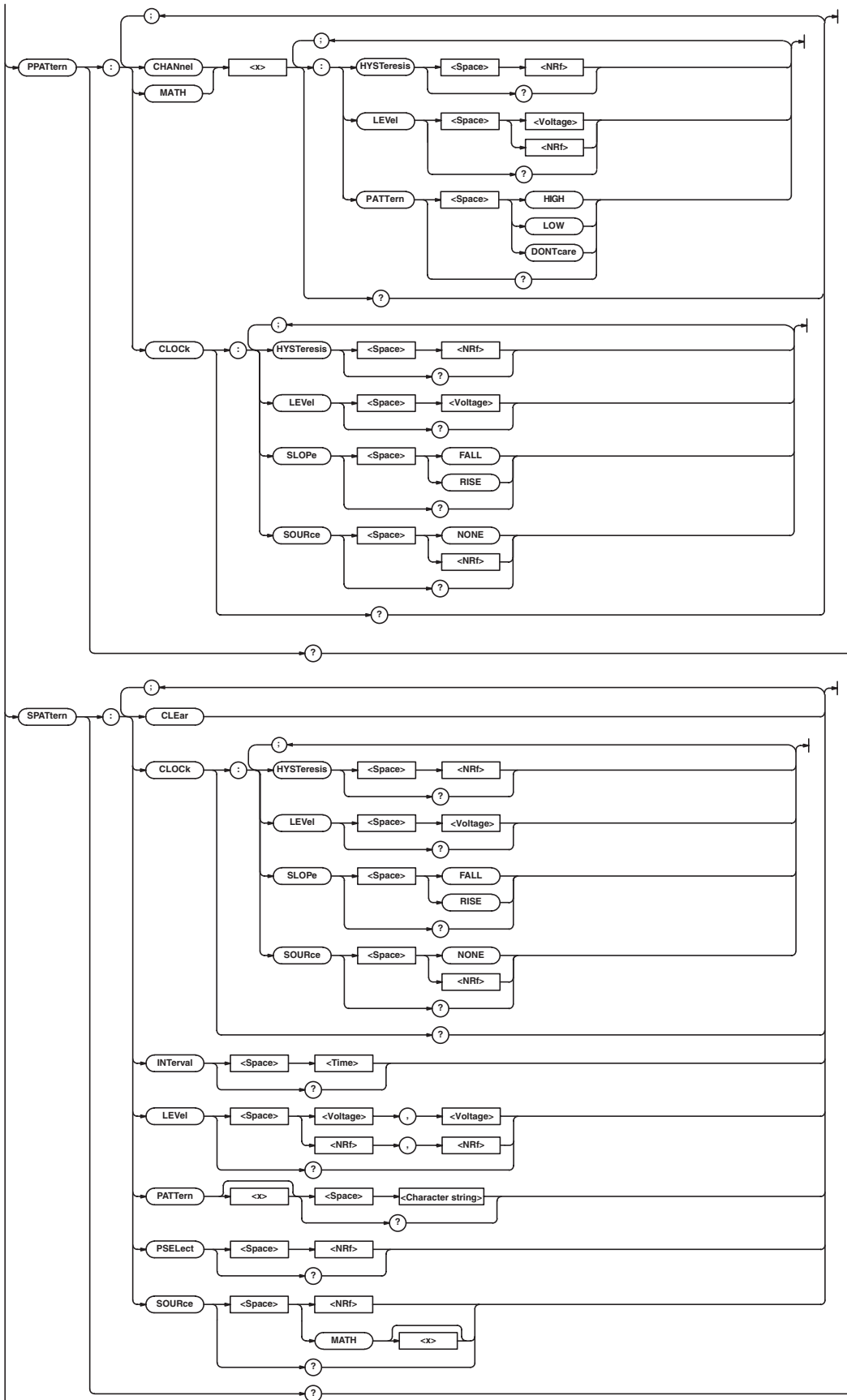

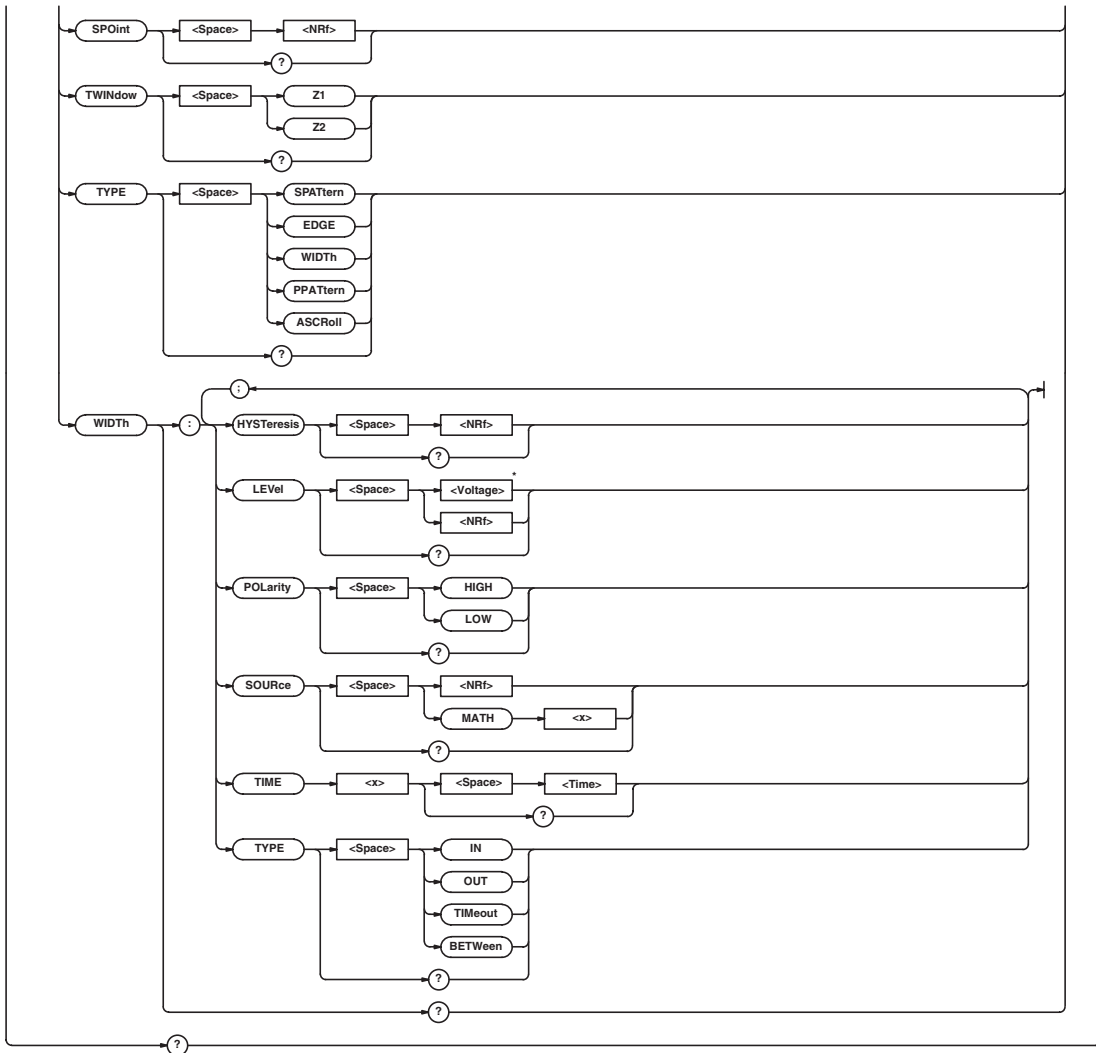

* When the target channel is set to the current probe, becomes <Current>.

5.21 SEARCh Group

:SEARCH?

Function Queries all settings related to the search & zoom function.

Syntax :SEARCH?

Example :SEARCH? -> :SEARCH:TYPE EDGE;EDGE:SOURCE 1;LEVEL 0.0E+00;SLOPE RISE;HYSTERESIS 0.30;COUNT 1;:SEARCH:SPATTERN:CLOCK:SOURCE NONE;;:SEARCH:SPATTERN:INTERVAL 10.000E-09;SOURCE 1;LEVEL 0.0E+00,0.0E+00;PSELECT 1;PATTERN1 "HXXXXXXXX";PATTERN2 "XXXXXXXX";PATTERN3 "XXXXXXXX";PATTERN4 "XXXXXXXX";PATTERN5 "XXXXXXXX";PATTERN6 "XXXXXXXX";PATTERN7 "XXXXXXXX";PATTERN8 "XXXXXXXX";:SEARCH:WIDTH:TYPE IN;SOURCE 1;LEVEL 0.0E+00;POLARITY HIGH;HYSTERESIS 0.30;TIME1 1.000000E-06;TIME2 1.000000E-06;:SEARCH:PPATTERN:CLOCK:SOURCE NONE;;:SEARCH:PPATTERN:CHANNEL1:LEVEL 0.0E+00;HYSTERESIS 0.30;PATTERN HIGH;;:SEARCH:PPATTERN:CHANNEL2:LEVEL 0.0E+00;HYSTERESIS 0.30;PATTERN DONTCARE;;:SEARCH:PPATTERN:CHANNEL3:LEVEL 0.0E+00;HYSTERESIS 0.30;PATTERN DONTCARE;;:SEARCH:PPATTERN:CHANNEL4:LEVEL 0.0E+00;HYSTERESIS 0.30;PATTERN DONTCARE;;:SEARCH:PPATTERN:MATH1:LEVEL 0.00;HYSTERESIS 0.30;PATTERN DONTCARE;;:SEARCH:ASCROLL:DIRECTION RIGHT;SPEED 0;;:SEARCH:TWINDOW Z1;MLINKAGE 1;MAG1 2.0;MAG2 2.0;PLINKAGE 0;POSITION1 0.0000000;POSITION2 0.0000000;SPOINT -5.0000000;SELECT NAN

:SEARCH:ABORT

Function Aborts the search when using the search & zoom function.

Syntax :SEARCH:ABORT

Example :SEARCH:ABORT

:SEARCH:ASCROLL?

Function Queries all settings related to the auto scroll of the search & zoom function.

Syntax :SEARCH:ASCROLL?

Example :SEARCH:ASCROLL? -> :SEARCH:ASCROLL:DIRECTION RIGHT;SPEED 0

:SEARCH:ASCROLL:DIRection

Function Sets the direction for moving the zoom box of the auto scroll when using the search & zoom function or queries the current setting.

Syntax :SEARCH:ASCROLL:DIRection {LEFT|RIGHT}

Example :SEARCH:ASCROLL:DIRection? -> :SEARCH:ASCROLL:DIRection? -> :SEARCH:ASCROLL:DIRection LEFT

:SEARCH:ASCROLL:SPEEd

Function Sets the speed for moving the zoom box of the auto scroll when using the search & zoom function or queries the current setting.

Syntax :SEARCH:ASCROLL:SPEEd {<NRf>} :SEARCH:ASCROLL:SPEEd? <NRf>=1 to 7

Example :SEARCH:ASCROLL:SPEED 1 :SEARCH:ASCROLL:SPEED? -> :SEARCH:ASCROLL:SPEED 1

:SEARCH:EDGE?

Function Queries all settings related to the edge search of the search & zoom function.

Syntax :SEARCH:EDGE?

Example :SEARCH:EDGE? -> :SEARCH:EDGE:SOURCE 1;LEVEL 0.0E+00;SLOPE RISE;HYSTERESIS LOW;COUNT 1

:SEARCH:EDGE:COUNT

Function Sets the edge detection count of the search & zoom function or queries the current setting.

Syntax :SEARCH:EDGE:COUNT {<NRf>} :SEARCH:EDGE:COUNT? <NRf>=1 to 100000

Example :SEARCH:EDGE:COUNT 100 :SEARCH:EDGE:COUNT? -> :SEARCH:EDGE:COUNT 100

:SEARCH:EDGE:HYSTEResis

Function Sets the hysteresis of the edge detection level of the search & zoom function or queries the current setting.

Syntax :SEARCH:EDGE:HYSTEResis {<NRf>} :SEARCH:EDGE:HYSTEResis? <NRf>=0.3 to 4 div (0.1 div steps)

Example :SEARCH:EDGE:HYSTERESIS 1 :SEARCH:EDGE:HYSTERESIS? -> :SEARCH:EDGE:HYSTERESIS 1.0

:SEARCH:EDGE:LEVEL

Function Sets the edge detection level of the search & zoom function or queries the current setting.

Syntax :SEARCH:EDGE:LEVEL {<voltage>|<NRf>} :SEARCH:EDGE:LEVEL? <voltage>=8 div on the screen (0.01 div steps) <NRf>=-4 to 4 div (0.01 div steps)

Example :SEARCH:EDGE:LEVEL -10mV :SEARCH:EDGE:LEVEL? -> :SEARCH:EDGE:LEVEL -10.00E-03

Description Specify a voltage when the ":SEARCH:EDGE:SOURCE" is set to channel (when set to the current probe, specify a current), <NRf> when it is set to MATH.

:SEARCH:EDGE:SLOPE

Function Sets the edge search slope of the search & zoom function or queries the current setting.

Syntax :SEARCH:EDGE:SLOPE {FALL|RISE}

Example :SEARCH:EDGE:SLOPE RISE :SEARCH:EDGE:SLOPE? -> :SEARCH:EDGE:SLOPE RISE

:SEARCH:EDGE:SOURCE

Function Sets the target waveform of the edge search of the search & zoom function or queries the current setting.

Syntax :SEARCH:EDGE:SOURCE {<NRf>|MATH<x>}
:SEARCH:EDGE:SOURCE?
<NRf>=1 to 4 (1 to 2 on the DL1720E)
<x>=1 or 2 (1 to the DL1720E)

Example :SEARCH:EDGE:SOURCE MATH1
:SEARCH:EDGE:SOURCE? ->
:SEARCH:EDGE:SOURCE MATH1

:SEARCH:EXECUTE

Function Executes the search using the search & zoom function. This is an overlap command.

Syntax :SEARCH:EXECUTE
Example :SEARCH:EXECUTE

:SEARCH:MLINKAGE (Mag Linkage)

Function Turns ON/OFF the link when changing the zoom rate of the search & zoom function or queries the current setting.

Syntax :SEARCH:MLINKAGE {<Boolean>}
:SEARCH:MLINKAGE?

Example :SEARCH:MLINKAGE ON
:SEARCH:MLINKAGE? ->
:SEARCH:MLINKAGE 1

:SEARCH:MAG<x>

Function Sets the zoom rate of the zoom window of the search & zoom function or queries the current setting.

Syntax :SEARCH:MAG<x> {<NRf>}
:SEARCH:MAG<x>?
<x>=1 or 2

<NRf>=Up to the point in which 40 points are displayed, see the User's Manual.

Example :SEARCH:MAG1 100
:SEARCH:MAG1? -> :SEARCH:MAG1 100

:SEARCH:PLINKAGE (Position Linkage)

Function Turns ON/OFF the link when moving the zoom box of the search & zoom function or queries the current setting.

Syntax :SEARCH:PLINKAGE {<Boolean>}
:SEARCH:PLINKAGE?

Example :SEARCH:PLINKAGE OFF
:SEARCH:PLINKAGE? ->
:SEARCH:PLINKAGE 0

:SEARCH:POSITION<x>

Function Sets the zoom box position of the search & zoom function or queries the current setting.

Syntax :SEARCH:POSITION<x> {<NRf>}
:SEARCH:POSITION<x>?
<x>=1 or 2
<NRf>=-5 to 5 div (10 div/displayed record length steps)

Example :SEARCH:POSITION1 2.5
:SEARCH:POSITION1? ->
:SEARCH:POSITION1 2.500000

:SEARCH:PPATTERN?

Function Queries all settings related to the parallel pattern search of the search & zoom function.

Syntax :SEARCH:PPATTERN?

Example :SEARCH:PPATTERN? -> :SEARCH:
PPATTERN:CLOCK:SOURCE NONE;
:SEARCH:PPATTERN:CHANNEL1:
LEVEL 0.0E+00;HYSTERESIS 0.30;
PATTERN HIGH;:SEARCH:PPATTERN:
CHANNEL2:LEVEL 0.0E+00;
HYSTERESIS 0.30;PATTERN DONTCARE;;
:SEARCH:PPATTERN:CHANNEL3:
LEVEL 0.0E+00;HYSTERESIS 0.30;
PATTERN DONTCARE;;:SEARCH:
PPATTERN:CHANNEL4:LEVEL 0.0E+00;
HYSTERESIS 0.30;PATTERN DONTCARE;;
:SEARCH:PPATTERN:MATH1:LEVEL 0.00;
HYSTERESIS 0.30;PATTERN DONTCARE;;
:SEARCH:PPATTERN:MATH2:LEVEL 0.00;
HYSTERESIS 0.30;PATTERN DONTCARE

:SEARCH:PPATTERN:{CHANNEL<x>|MATH<x>}?

Function Queries all settings related to the waveform of the parallel pattern search of the search & zoom function.

Syntax :SEARCH:PPATTERN:{CHANNEL<x>|
MATH<x>}?
<x> of CHANNEL<x>=1 to 4 (1 to 2 on the
DL1720E)

<x> of MATH<x>=1 or 2 (1 on the DL1720E)

Example :SEARCH:PPATTERN:CHANNEL1? ->
:SEARCH:PPATTERN:CHANNEL1:
LEVEL 0.0E+00;HYSTERESIS 0.30;
PATTERN HIGH

**:SEARCH:PPATTERN:{CHANNEL<x>|MATH<x>}:
HYSTERESIS**

Function Sets the hysteresis of the edge detection level of the target waveform of the parallel pattern search using the search & zoom function or queries the current setting.

Syntax :SEARCH:PPATTERN:{CHANNEL<x>|
MATH<x>}:HYSTERESIS {<NRf>}
:SEARCH:PPATTERN:{CHANNEL<x>|
MATH<x>}:HYSTERESIS?
<x> of CHANNEL<x>=1 to 4 (1 to 2 on the
DL1720E)

<x> of MATH<x>=1 or 2 (1 on the DL1720E)
<NRf>=0.3 to 4 div (0.1 steps)

Example :SEARCH:PPATTERN:CHANNEL1:
HYSTERESIS 0.3
:SEARCH:PPATTERN:CHANNEL1:
HYSTERESIS? -> :SEARCH:PPATTERN:
CHANNEL1:HYSTERESIS 0.30

5.21 SEARCh Group

:SEARCH:PPATtern:{CHANnel<x>|MATH<x>}:LEVEL

Function	Sets the criteria level of the target waveform of the parallel pattern search using the search & zoom function or queries the current setting.
Syntax	:SEARCH:PPATtern:{CHANnel<x> MATH<x>}:LEVEL {<voltage> <NRf>} :SEARCH:PPATtern:{CHANnel<x> MATH<x>}:LEVEL? <x> of CHANnel<x>=1 to 4 (1 to 2 on the DL1720E) <x> of MATH<x>=1 or 2 (1 on the DL1720E) <voltage>=8 div on the screen (when the waveform is CH1 to CH4) <NRf>=-4 to 4 div (0.01 steps when the waveform is MATH1 or MATH2)
Example	:SEARCH:PPATtern:CHANNEL1:LEVEL 1v :SEARCH:PPATtern:CHANNEL1:LEVEL? -> :SEARCH:PPATtern:CHANNEL1: LEVEL 1.000E+00
Description	When set to the current probe, sets the <Current> value or queries the current setting.

:SEARCH:PPATtern:{CHANnel<x>|MATH<x>}:PATTERN

Function	Sets the criteria status of the target waveform of the parallel pattern search using the search & zoom function or queries the current setting.
Syntax	:SEARCH:PPATtern:{CHANnel<x> MATH<x>}:PATTern {HIGH LOW DONTcare} :SEARCH:PPATtern:{CHANnel<x> MATH<x>}:PATTern? <x> of CHANnel<x>=1 to 4 (1 to 2 on the DL1720E) <x> of MATH<x>=1 or 2 (1 on the DL1720E)
Example	:SEARCH:PPATtern:CHANNEL1: PATTERN HIGH :SEARCH:PPATtern:CHANNEL1: PATTERN? -> :SEARCH:PPATtern: CHANNEL1:PATTERN HIGH

:SEARCH:PPATtern:CLOCK?

Function	Queries all settings related to the clock channel of the parallel pattern search of the search & zoom function.
Syntax	:SEARCH:PPATtern:CLOCK?
Example	:SEARCH:PPATtern:CLOCK? -> :SEARCH:PPATtern:CLOCK:SOURCE 1; LEVEL 1.000E+00;HYSTERESIS 0.30; SLOPE RISE

:SEARCH:PPATtern:CLOCK:HYSYeresis

Function	Sets the search level hysteresis of the clock channel of the parallel pattern search using the search & zoom function or queries the current setting.
Syntax	:SEARCH:PPATtern:CLOCK: HYSYeresis {<NRf>} :SEARCH:PPATtern:CLOCK:HYSYeresis? <NRf>=0.3 to 4 div (0.1 steps)
Example	:SEARCH:PPATtern:CLOCK: HYSTERESIS 4.0 :SEARCH:PPATtern:CLOCK: HYSTERESIS? -> :SEARCH:PPATtern: CLOCK:HYSTERESIS 4.00
Description	An error occurs if “:SEARCH:PPATtern:CLOCK:SOURCE” is set to “NONE.”

:SEARCH:PPATtern:CLOCK:LEVEL

Function	Sets the search level of the clock channel of the parallel pattern search using the search & zoom function or queries the current setting.
Syntax	:SEARCH:PPATtern:CLOCK: LEVEL {<voltage>} :SEARCH:PPATtern:CLOCK:LEVEL? 8 divisions within the screen (0.01 division steps).
Example	:SEARCH:PPATtern:CLOCK:LEVEL 1V :SEARCH:PPATtern:CLOCK:LEVEL? -> :SEARCH:PPATtern:CLOCK: LEVEL 1.000E+00
Description	<ul style="list-style-type: none"> An error occurs if “:SEARCH:PPATtern:CLOCK:SOURCE” is set to “NONE.” When set to the current probe, sets the <Current> value or queries the current setting.

:SEARCH:PPATtern:CLOCK:SLOPE

Function	Sets the slope of the clock channel of the parallel pattern search using the search & zoom function or queries the current setting.
Syntax	:SEARCH:PPATtern:CLOCK: SLOPE {FALL RISE} :SEARCH:PPATtern:CLOCK:SLOPE?
Example	:SEARCH:PPATtern:CLOCK:SLOPE FALL :SEARCH:PPATtern:CLOCK:SLOPE? -> :SEARCH:PPATtern:CLOCK:SLOPE FALL
Description	An error occurs if “:SEARCH:PPATtern:CLOCK:SOURCE” is set to “NONE.”

:SEARCH:PPATtern:CLOCK:SOURCE

Function	Sets the target waveform of the clock channel of the parallel pattern search using the search & zoom function or queries the current setting.
Syntax	:SEARCH:PPATtern:CLOCK: SOURCE {NONE <NRf>} :SEARCH:PPATtern:CLOCK:SOURCE? <NRf>=1 to 4 (1 to 2 on the DL1720E)
Example	:SEARCH:PPATtern:CLOCK:SOURCE 1 :SEARCH:PPATtern:CLOCK:SOURCE? -> :SEARCH:PPATtern:CLOCK:SOURCE 1

:SEARCH:SElect

Function Sets the detection waveform number of the search & zoom function and queries the zoom position corresponding to the detection waveform number.

Syntax :SEARCH:SElect {<NRf>|MAXimum}
:SEARCH:SElect?
<NRf>=1 to 1000

Example :SEARCH:SELECT 1
:SEARCH:SELECT? ->
:SEARCH:SELECT 2.500000

Description If no positions are found, "NAN" is returned.

:SEARCH:SElect? MAXimum

Function Queries the detection count of the search & zoom function.

Syntax :SEARCH:SElect? {MAXimum}

Example :SEARCH:SELECT? MAXIMUM ->
:SEARCH:SELECT 100

Description If no positions are found, "NAN" is returned.

:SEARCH:SPATtern? (Serial Pattern)

Function Queries all settings related to the serial pattern search of the search & zoom function.

Syntax :SEARCH:SPATtern?

Example :SEARCH:SPATTERN? -> :SEARCH:
SPATTERN:CLOCK:SOURCE NONE;;
SEARCH:SPATTERN:INTERVAL 1.0E-06;
SOURCE 1;LEVEL 0.0E+00;PSELECT 1;
PATTERN1 "XXXXXXXX";
PATTERN2 "XXXXXXXX";
PATTERN3 "XXXXXXXX";
PATTERN4 "XXXXXXXX";
PATTERN5 "XXXXXXXX";
PATTERN6 "XXXXXXXX";
PATTERN7 "XXXXXXXX";
PATTERN8 "XXXXXXXX"

:SEARCH:SPATtern:CLEar

Function Clears all search patterns of the serial pattern search using the search & zoom function (to Do't care).

Syntax :SEARCH:SPATtern:CLEar

Example :SEARCH:SPATTERN:CLEAR

:SEARCH:SPATtern:CLOCK?

Function Queries all settings related to the clock channel of the serial pattern search of the search & zoom function.

Syntax :SEARCH:SPATtern:CLOCK?

Example :SEARCH:SPATTERN:CLOCK? ->
:SEARCH:SPATTERN:CLOCK:SOURCE 1;
LEVEL 0.0E+00;SLOPE RISE;
HYSTERESIS 0.3

:SEARCH:SPATtern:CLOCK:HYSTEResis

Function Sets the hysteresis of the edge detection level of the clock channel of the serial pattern search using the search & zoom function or queries the current setting.

Syntax :SEARCH:SPATtern:CLOCK:HYSTEResis
{<NRf>}
:SEARCH:SPATtern:CLOCK:HYSTEResis?
<NRf>=0.3 to 4 div (0.1 steps)

Example :SEARCH:SPATTERN:CLOCK:HYSTERESIS 1
:SEARCH:SPATTERN:CLOCK:HYSTERESIS?
-> :SEARCH:SPATTERN:CLOCK:
HYSTERESIS 1.0

Description An error occurs if
":SEAEch:SPATtern:CLOCK:SOURCE" is set
to "NONE."

:SEARCH:SPATtern:CLOCK:LEVEL

Function Sets the search level of the clock channel of the serial pattern search using the search & zoom function or queries the current setting.

Syntax :SEARCH:SPATtern:CLOCK:LEVEL
{<voltage>}

Example :SEARCH:SPATtern:CLOCK:LEVEL?
<voltage>=8 div on the screen (0.01 div steps)
:SEARCH:SPATTERN:CLOCK:LEVEL -10MV
:SEARCH:SPATTERN:CLOCK:LEVEL? ->
:SEARCH:SPATTERN:CLOCK:
LEVEL -10.00E-03

Description • An error occurs if
":SEAEch:SPATtern:CLOCK:SOURCE" is
set to "NONE."
• When set to the current probe, sets the
<Current> value or queries the current
setting.

:SEARCH:SPATtern:CLOCK:SLOPE

Function Sets the slope of the clock channel of the serial pattern search using the search & zoom function or queries the current setting.

Syntax :SEARCH:SPATtern:CLOCK:SLOPE
{FALL|RISE}

Example :SEARCH:SPATtern:CLOCK:SLOPE?
:SEARCH:SPATTERN:CLOCK:SLOPE RISE
:SEARCH:SPATTERN:CLOCK:SLOPE? ->
:SEARCH:SPATTERN:CLOCK:SLOPE RISE

Description An error occurs if
":SEAEch:SPATtern:CLOCK:SOURCE" is set
to "NONE."

:SEARCH:SPATtern:CLOCK:SOURCE

Function Sets the target waveform of the clock channel of the serial pattern search using the search & zoom function or queries the current setting.

Syntax :SEARCH:SPATtern:CLOCK:SOURCE
{<NRf>|NONE}
:SEARCH:SPATtern:CLOCK:SOURCE?
<NRf>=1 to 4 (1 to 2 on the DL1720E)

Example :SEARCH:SPATTERN:CLOCK:SOURCE 1
:SEARCH:SPATTERN:CLOCK:SOURCE? ->
:SEARCH:SPATTERN:SOURCE 1

5.21 SEARCh Group

:SEARCH:SPATtern:INTERval

Function Sets the search interval of search target waveform of the serial pattern search using the search & zoom function or queries the current setting.

Syntax :SEARCH:SPATtern:INTERval {<time>}
:SEARCH:SPATtern:INTERval?
<time>=10 ps to 500 s

Example :SEARCH:SPATtern:INTERval 100US
:SEARCH:SPATtern:INTERval? ->
:SEARCH:SPATtern:
INTERval 100.00E-06

:SEARCH:SPATtern:LEVel

Function Sets the upper and lower limits of the status criteria level of the serial pattern search using the search & zoom function or queries the current setting.

Syntax :SEARCH:SPATtern:LEVel
{<voltage>,<voltage>|<NRf>,<NRf>}
:SEARCH:SPATtern:LEVel?
<voltage>=8 div on the screen (when the waveform is CH1 to CH4)
<NRf>=-4 to 4 div (0.01 steps when the waveform is MATH1 or MATH2)

Example :SEARCH:SPATtern:LEVel -1V,1V
:SEARCH:SPATtern:LEVel? ->
:SEARCH:SPATtern:
LEVel -1.000E+00,1.000E+00

Description When set to the current probe, sets the <Current> value or queries the current setting.

:SEARCH:SPATtern:PATtern<x>

Function Sets the status criteria pattern of the serial pattern search using the search & zoom function or queries the current setting.

Syntax :SEARCH:SPATtern:PATtern<x>
<Character string>
:SEARCH:SPATtern:PATtern<x>?
<x>=1 to 8
<Character string>=8 characters of the combination of 'H','L', and 'X' (The left most character represents the smallest bit. Total of 8 bits.)

Example :SEARCH:SPATtern:
PATtern1 "HLXHLXHL"
:SEARCH:SPATtern:PATtern1? ->
:SEARCH:SPATtern:
PATtern1 "HLXHLXHL"

Description

- <x> represents the 8 bit block number. Thus, when <x>=1, the left most character represents bit 0 and the right most character represents bit 7. The relationship between <x> and the character string is as follows.
<x>=1: <character string>=bits 0 to 7,
<x>=2: <character string>=bits 8 to 15,
<x>=3: <character string>=bits 16 to 23,
<x>=4: <character string>=bits 24 to 31,
<x>=5: <character string>=bits 32 to 39,
<x>=6: <character string>=bits 40 to 47,
<x>=7: <character string>=bits 48 to 55,
<x>=8: <character string>=bits 56 to 63
- The pattern is assigned the pattern number that is selected with the
":SEARCH:SPATtern:PSElect" command.

:SEARCH:SPATtern:PSElect (Pattern Select)

Function Sets the pattern number to which the status criteria pattern is assigned in the serial pattern search using the search & zoom function or queries the current setting.

Syntax :SEARCH:SPATtern:PSElect {<NRf>}
:SEARCH:SPATtern:PSElect?
<x>=1 to 4

Example :SEARCH:SPATtern:PSElect 1

Description The values 1 to 4 of <x> correspond to pattern A to D.

:SEARCH:SPATtern:SOURce

Function Sets the search target waveform of the serial pattern search using the search & zoom function or queries the current setting.

Syntax :SEARCH:SPATtern:SOURce
{<NRf>|<MATHx>}
:SEARCH:SPATtern:SOURce?
<NRf>=1 to 4 (1 to 2 on the DL1720E)
<x>=1 or 2 (1 on the DL1720E)

Example :SEARCH:SPATtern:SOURce 1
:SEARCH:SPATtern:SOURce? ->
:SEARCH:SPATtern:SOURce 1

:SEARCH:SPOint (Start Point)

Function Sets the search start point of the search & zoom function or queries the current setting.

Syntax :SEARCH:SPOint {<NRf>}
:SEARCH:SPOint?
<NRf>=-5 to 5 div (10 div/displayed record length steps)

Example :SEARCH:SPOint 3
:SEARCH:SPOint? ->
:SEARCH:SPOint 3.0000000

:SEARCH:TWInDow (Target WinDow)

Function Sets the zoom window on which the searched section is displayed using the search & zoom function or queries the current setting.

Syntax :SEARCH:TWInDow {Z1|Z2}
:SEARCH:TWInDow?

Example :SEARCH:TWInDow Z1:SEARCH:TWInDow?
-> :SEARCH:TWInDow Z1

:SEARCH:TYPE

Function Sets the search type of the search & zoom function or queries the current setting.

Syntax :SEARCH:TYPE
{SPATtern|WIDTh|EDGE|PPATtern|ASCroll|SPI}
:SEARCH:TYPE?

Example :SEARCH:TYPE SPATtern
:SEARCH:TYPE? ->
:SEARCH:TYPE SPATtern

:SEARCH:WIDTh?

Function Queries all settings related to the pulse width search of the search & zoom function.

Syntax :SEARCH:WIDTh?

Example :SEARCH:WIDTh? ->
:SEARCH:WIDTh:TYPE IN;SOURce 1;
LEVel 0.0E+00;POLARITY HIGH;
HYSTERESIS 0.30;TIME1 1.000000E-06;
TIME2 1.000000E-06

:SEARCH:WIDTH:HYSteresis

Function Sets the hysteresis of the pulse width search level of the search & zoom function or queries the current setting.

Syntax :SEARCH:WIDTH:HYSteresis {<NRf>}
:SEARCH:WIDTH:HYSteresis?
<NRf>=0.3 to 4.0 div (0.1 steps)

Example :SEARCH:WIDTH:HISTERESIS 0.3
:SEARCH:WIDTH:HISTERESIS? ->
:SEARCH:WIDTH:HYSterESIS 0.30

:SEARCH:WIDTH:LEVel

Function Sets the pulse width search level of the search & zoom function or queries the current setting.

Syntax :SEARCH:WIDTH:LEVel
{<voltage>|<NRf>}
:SEARCH:WIDTH:LEVel?
<voltage>=8 div on the screen (0.01div steps)
<NRf>=-4 to 4 div (0.01div steps)

Example :SEARCH:WIDTH:LEVEL 1V
:SEARCH:WIDTH:LEVEL? ->
:SEARCH:WIDTH:LEVEL 1.000E+00

Description When set to the current probe, sets the <Current> value or queries the current setting.

:SEARCH:WIDTH:POLarity

Function Sets the polarity of the pulse width search level of the search & zoom function or queries the current setting.

Syntax :SEARCH:WIDTH:POLarity {HIGH|LOW}
:SEARCH:WIDTH:POLarity?

Example :SEARCH:WIDTH:POLARUTY HIGH
:SEARCH:WIDTH:POLARITY? ->
:SEARCH:WIDTH:POLARITY HIGH

:SEARCH:WIDTH:SOURce

Function Sets the target waveform of the pulse width search of the search & zoom function or queries the current setting.

Syntax :SEARCH:WIDTH:SOURce
{<NRf>|MATH<x>}
:SEARCH:WIDTH:SOURce?
<NRf>=1 to 4 (1 to 2 on the DL1720E)
<x>=1 or 2 (1 on the DL1720E)

Example :SEARCH:WIDTH:SOURCE 1
:SEARCH:WIDTH:SOURCE? ->
:SEARCH:WIDTH:SOURCE 1

:SEARCH:WIDTH:TIME<x>

Function Sets the pulse width of the pulse width search of the search & zoom function or queries the current setting.

Syntax :SEARCH:WIDTH:TIME<x> {<time>}
:SEARCH:WIDTH:TIME<x>?
<x>=1 or 2
<time>=10 ps to 500 s (when <x>=1 and
"T1<Pulse<T2" is not true)
10 ps to 499.95 s (when <x>=1 and
"T1<Pulse<T2")
20 ps to 500 s (when <x>=2 and
"T1<Pulse<T2")

Example :SEARCH:WIDTH:TIME1 20PS
:SEARCH:WIDTH:TIME1? ->
:SEARCH:WIDTH:TIME1 20.0E-12

:SEARCH:WIDTH:TYPE

Function Sets the search type of the pulse width search of the search & zoom function or queries the current setting.

Syntax :SEARCH:WIDTH:TYPE
{IN|OUT|TIMEout|BETWEEN|NOTBetween}
:SEARCH:WIDTH:TYPE?

Example :SEARCH:WIDTH:TYPE IN
:SEARCH:WIDTH:TYPE? ->
:SEARCH:WIDTH:TYPE IN

5.22 SNAP Group

The SNAP command is used to execute a snapshot. The same function can be performed using SNAPSHOT on the front panel.



: SNAP

Function Executes a snapshot.
 Syntax :SNAP
 Example :SNAP

5.23 SStart Group

The commands in the SStart group are used to execute the single start operation. It operates in the same fashion as the single trigger.

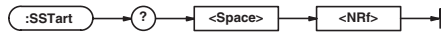

: SStart?

Function Starts the data acquisition with the trigger mode set to single. If the operation is stopped within the specified time period, 0 is returned. Otherwise, 1 is returned.

Syntax :SStart? {<NRf>}
 <NRf>=1 to 36000 (100 ms resolution: wait period, START and wait)
 0 (START only. No wait.)
 -36000 to -1 (100 ms resolution: wait period, START and wait)

Example :SSTART? 100 -> :SSTART 0

Description

- If the specified time period is positive, data acquisition is started in the SINGLE TRIGGER mode and waits for the operation to stop.
- If the specified time period is 0, data acquisition is started and 0 is returned without waiting for the operation to stop.
- If the specified time period is negative, the instrument simply waits for the operation to stop. Data acquisition is not started.

5.24 START Group

The START command is used to start acquisition. The same function can be performed by pressing START/STOP on the front panel.

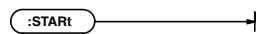

: START

Function Starts acquisition.
 Syntax :START
 Example :START
 Description To stop acquisition, use "STOP."

5.25 STATUS Group

The commands in the STATUS group are used to make settings and queries about the status report. There is no front panel key for this function. For details of the status report, refer to Chapter 6.

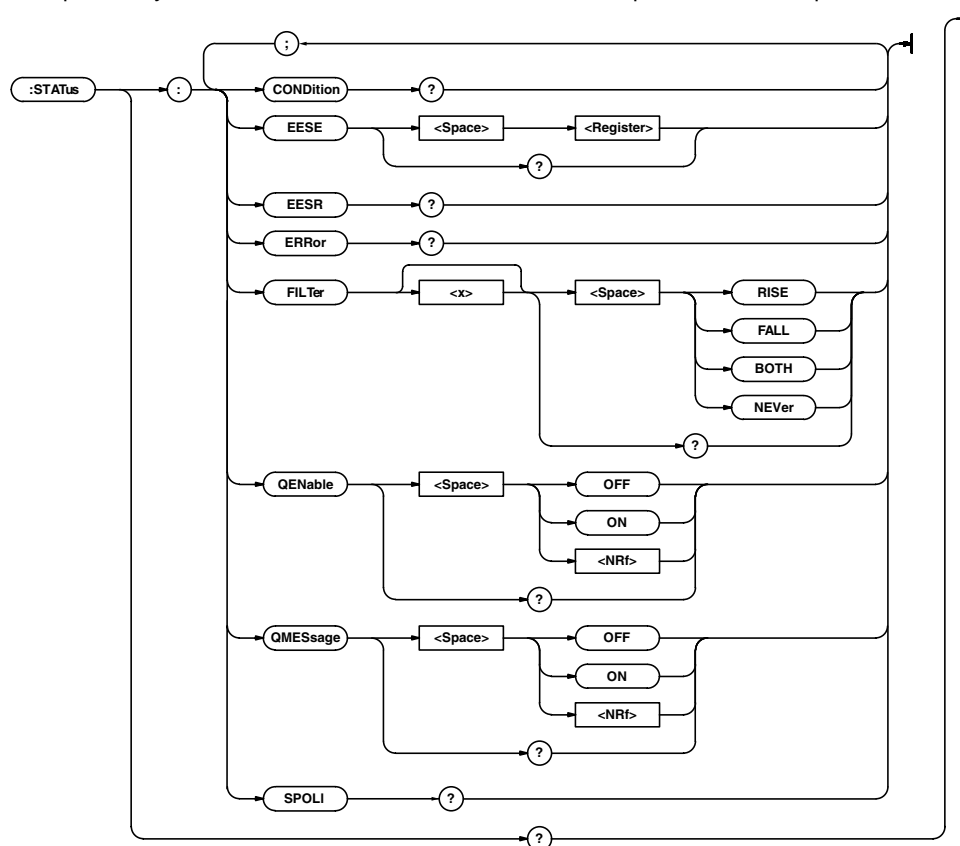

:STATUS?

Function Inquires about all the settings relating to the communications status function.

Syntax :STATUS?

Example :STATUS? -> :STATUS:EESER 0;
 FILTER1 NEVER;FILTER2 NEVER;
 FILTER3 NEVER;FILTER4 NEVER;
 FILTER5 NEVER;FILTER6 NEVER;
 FILTER7 NEVER;FILTER8 NEVER;
 FILTER9 NEVER;FILTER10 NEVER;
 FILTER11 NEVER;FILTER12 NEVER;
 FILTER13 NEVER;FILTER14 NEVER;
 FILTER15 NEVER;FILTER16 NEVER;
 QENABLE 1;QMESSAGE 1

:STATUS:CONDition?

Function Queries the contents of the condition register, and clears the register.

Syntax :STATUS:CONDition?

Example :STATUS:CONDition? -> 16

Description For a description of the event register, refer to chapter 6.

:STATUS:EESER

Function Sets/queries the extended event enable register.

Syntax :STATUS:EESER <Register>
 :STATUS:EESER?

Example :STATUS:EESER #B00000000

:STATUS:EESER? -> :STATUS:EESER 0

Description For a description of the event register, refer to chapter 6.

:STATUS:EESR?

Function Queries the content of the extended event register, and clears the register.

Syntax :STATUS:EESR?

Example :STATUS:EESR? -> 1

Description For a description of the event register, refer to chapter 6.

:STATUS:ERRor?

Function Queries the code and message (at the beginning of the error queue) of the error which has occurred.

Syntax :STATUS:ERRor?

Example :STATUS:ERRor? ->
 113",Undefined header"

5.25 STATus Group/5.26 STOP Group

:STATus:FILTER<x>

Function Sets/queries the transit filter.
Syntax **:STATus:FILTER<x>**
{RISE|FALL|BOTH|NEVer}
:STATus:FILTER<x>?
<x>=1 to 16
Example **:STATus:FILTER2 RISE**
:STATus:FILTER2? -> :STATus:FILTER2
RISE
Description For a description of the event register, refer to chapter 6.

:STATus:QENable

Function Selects/queries whether messages other than errors are stored in the error queue.
Syntax **:STATus:QENable {<Boolean>}**
:STATus:QENable?
Example **:STATus:QENABLE ON**
:STATus:QENABLE? ->
:STATus:QENABLE 1

:STATus:QMESsage

Function Selects/queries whether message content is appended to responses to "STATus:ERRor?".
Syntax **:STATus:QMESsage {<Boolean>}**
:STATus:QMESsage?
Example **:STATus:QMESsage ON**
:STATus:QMESsage? ->
:STATus:QMESsage 1

:STATus:SPOLL? (Serial Poll)

Function Executes the serial polling.
Syntax **:STATus:SPOLL?**
Example **:STATus:SPOLL? -> :STATus:SPOLL 0**
Description This is an exclusive command for the USB interface or the Ethernet interface (option).

5.26 STOP Group

The STOP command is used to stop acquisition. The same function can be performed using START/STOP on the front panel.

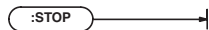

:STOP

Function Stops acquisition.
Syntax **:STOP**
Example **:STOP**
Description To start acquisition, use "START."

5.27 STORE Group

The commands in the STORE group are used to store the setup data from the internal memory. These commands can be used to carry out the same operations as when SETUP on the front panel is pressed.

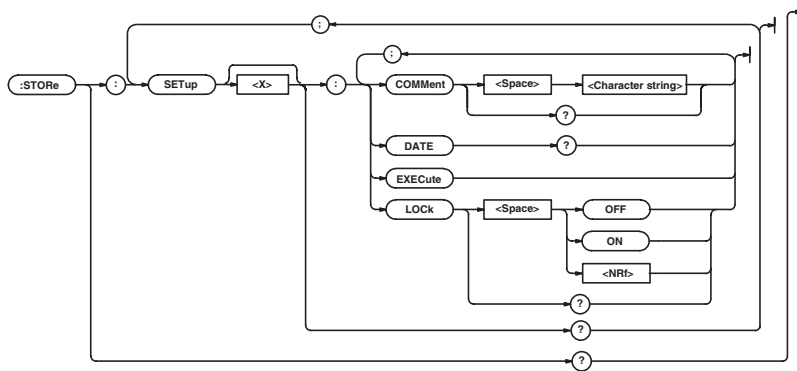

:STORE?

Function Queries information about the setting parameters that are stored to the internal memory.

Syntax :STORE?

Example :STORE? -> :STORE:SETUP1:
COMMENT " ";LOCK 0;:STORE:SETUP2:
COMMENT " ";LOCK 0;:STORE:SETUP3:
COMMENT " ";LOCK 0

:STORE:SETUP<x>?

Function Queries information about the setting parameters that are stored to the internal memory at the specified number.

Syntax :STORE:SETUP<x>?
<x>=1 to 3

Example :STORE:SETUP1? -> :STORE:SETUP1:
COMMENT "WAVE1";LOCK 0

:STORE:SETUP<x>:COMMENT

Function Sets comments for the setting parameters that are to be stored to the internal memory at the specified number or queries the current setting.

Syntax :STORE:SETUP<x>:COMMENT
<Character string>
:STORE:SETUP<x>:COMMENT?
<x>=1 to 3
<Character string>:Within 8 characters.

Example :STORE:SETUP1:COMMENT "WAVE1"
:STORE:SETUP1:COMMENT? ->
:STORE:SETUP1:COMMENT "WAVE1"

:STORE:SETUP<x>:DATE?

Function Queries the date and time for the setting parameters that are stored to the internal memory at the specified number.

Syntax :STORE:SETUP<x>:DATE?
<x>=1 to 3

Example :STORE:SETUP1:DATE? -> :STORE:
SETUP1:DATE? "04/07/04 17:30:34"

:STORE:SETUP<x>:EXECUTE

Function Saves the setting parameters to the internal memory at the specified number.

Syntax :STORE:SETUP<x>:EXECUTE
<x>=1 to 3

Example :STORE:SETUP1:EXECUTE

:STORE:SETUP<x>:LOCK

Function Turns ON/OFF the protection for the setting parameters that are stored to the internal memory at the specified number or queries the current setting.

Syntax :STORE:SETUP<x>:LOCK {<Boolean>}
:STORE:SETUP<x>:LOCK?
<x>=1 to 3

Example :STORE:SETUP1:LOCK ON
:STORE:SETUP1:LOCK? ->
:STORE:SETUP1:LOCK 1

5.28 SYSTEM Group

The commands in the SYSTEM group are used to make settings and queries about the system. The same settings can be made using the System Config menu obtained when MISC on the front panel is pressed.

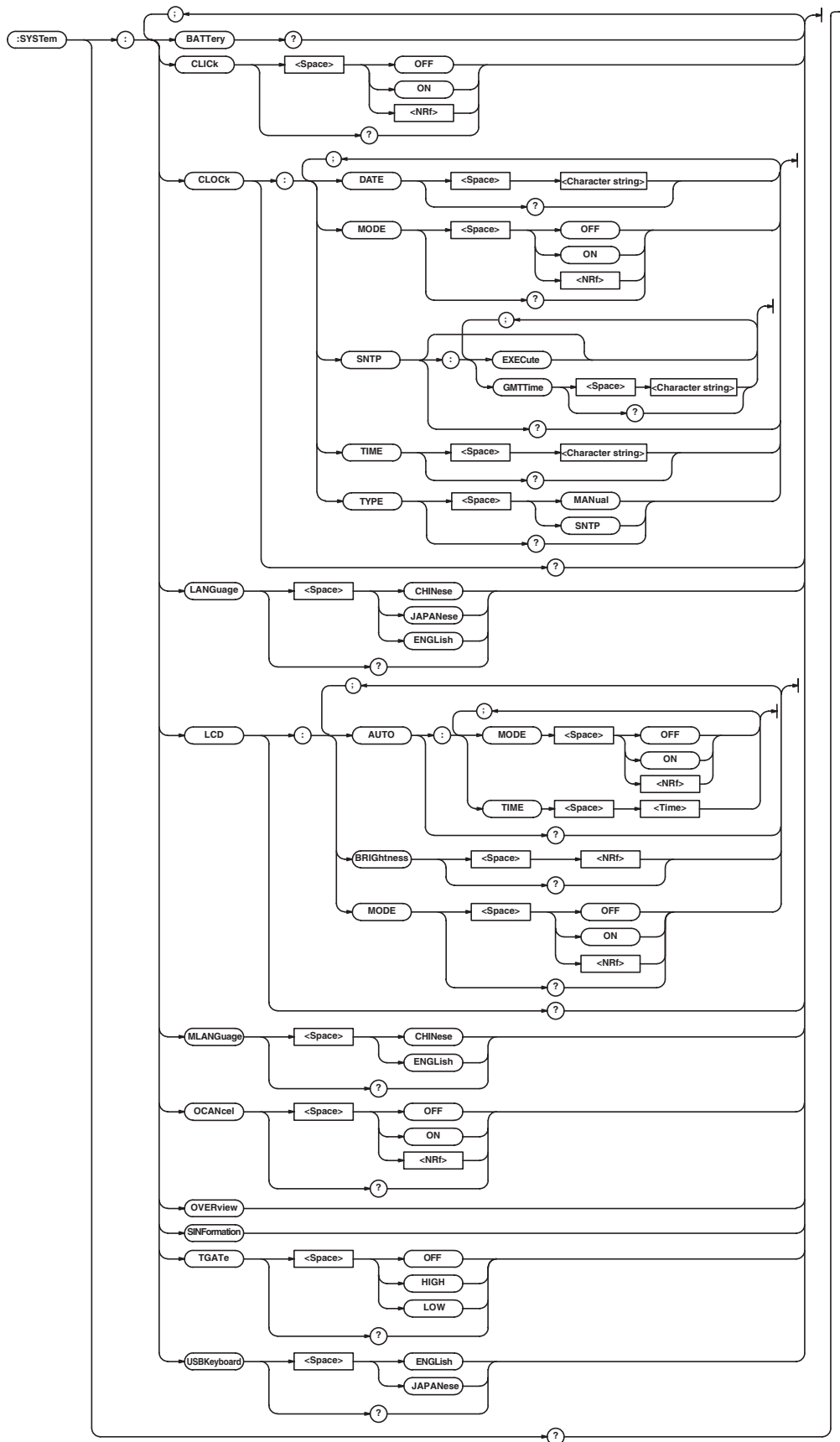

:SYSTEM?

Function Queries all system settings.
 Syntax :SYSTEM?
 Example :SYSTEM? -> :SYSTEM:SCSI:OWNID 0;;
 :SYSTEM:CLOCK:MODE 1;
 DATE "2004/06/19";TIME "17:47:17";
 :SYSTEM:LANGUAGE JAPANESE;CLICK 1;
 TGATE OFF;LCD:MODE 1;BRIGHTNESS 4;
 AUTO:MODE 0;TIME 1;;SYSTEM:
 OCANCEL 0

:SYSTEM:BATTERY?

Function Queries the condition of the internal lithium battery.
 Syntax :SYSTEM:BATTERY?
 Example :SYSTEM:BATTERY? ->
 :SYSTEM:BATTERY 1
 Description "1" is returned if the battery is functioning, and "0" is returned if the battery has run out.

:SYSTEM:CLICK

Function Sets the click sound ON or OFF, or queries the current setting.
 Syntax :SYSTEM:CLiCk {<Boolean>}
 :SYSTEM:CLiCk?
 Example :SYSTEM:CLICK ON
 :SYSTEM:CLICK? -> :SYSTEM:CLICK 1

:SYSTEM:CLOCK?

Function Queries all settings related to date and time.
 Syntax :SYSTEM:CLOCK?
 Example :SYSTEM:CLOCK? ->
 :SYSTEM:CLOCK:MODE 1;TYPE SNTP;
 DATE "2004/06/19";TIME "17:47:17";
 SNTP:GMTTIME "09:00"

:SYSTEM:CLOCK:DATE

Function Sets/queries the date.
 Syntax :SYSTEM:CLOCK:DATE <Character string>
 :SYSTEM:CLOCK:DATE?
 <Character string>=YY/MM/DD, refer to User's Manual.
 Example :SYSTEM:CLOCK:DATE "2004/07/30"
 :SYSTEM:CLOCK:DATE? ->
 :SYSTEM:CLOCK:DATE "2004/07/30"

:SYSTEM:CLOCK:MODE

Function Turns the date and time display ON/OFF or queries the current setting.
 Syntax :SYSTEM:CLOCK:MODE {<Boolean>}
 :SYSTEM:CLOCK:MODE?
 Example :SYSTEM:CLOCK:MODE ON
 :SYSTEM:CLOCK:MODE? ->
 :SYSTEM:CLOCK:MODE 1

:SYSTEM:CLOCK:SNTP?

Functions Queries the SNTP dettings.
 Syntax :SYSTEM:CLOCK:SNTP?
 Example :SYSTEM:CLOCK:SNTP?->
 :SYSTEM:CLOCK:SNTP:GMTTIME "09:00"

:SYSTEM:CLOCK:SNTP:EXECute

Functions Execute date and time setting per SNTP server.
 Syntax :SYSTEM:CLOCK:SNTP:EXECute
 Example :SYSTEM:CLOCK:SNTP:EXECUTE

:SYSTEM:CLOCK:SNTP:GMTTime

Functions Sets/queries the difference from Greenwich mean time.
 Syntax :SYSTEM:CLOCK:SNTP:GMTTime
 <Character string>
 :SYSTEM:CLOCK:SNTP:GMTTime?
 <Character string>=HH:MM, See the User's Manual.
 Example :SYSTEM:CLOCK:SNTP:GMTTIME "09:00"
 :SYSTEM:CLOCK:SNTP:GMTTIME? ->
 :SYSTEM:CLOCK:SNTP:GMTTIME "09:00"

:SYSTEM:CLOCK:TIME

Function Sets the time or queries the current setting.
 Syntax :SYSTEM:CLOCK:TIME <Character string>
 :SYSTEM:CLOCK:TIME?
 <Character string>=HH:MM:SS, See the User's Manual.
 Example :SYSTEM:CLOCK:TIME "14:30:00"
 :SYSTEM:CLOCK:TIME? ->
 :SYSTEM:CLOCK:TIME "14:30:00"

:SYSTEM:CLOCK:TYPE

Functions Sets/queries the date and time setting method.
 Syntax :SYSTEM:CLOCK:TYPE {MANual|SNTP}
 :SYSTEM:CLOCK:TYPE?
 Example :SYSTEM:CLOCK:TYPE MANUAL
 :SYSTEM:CLOCK:TYPE? ->
 :SYSTEM:CLOCK:TYPE MANUAL

:SYSTEM:LANGUAGE

Function Sets/queries the message language.
 Syntax :SYSTEM:LANGUage
 {ENGLiSh|JAPANese|CHINese}
 :SYSTEM:LANGUage?
 Example :SYSTEM:LANGUAGE JAPANESE
 :SYSTEM:LANGUAGE? ->
 :SYSTEM:LANGUAGE JAPANESE

:SYSTEM:LCD?

Function Queries all settings related to the LCD monitor.
 Syntax :SYSTEM:LCD?
 Example :SYSTEM:LCD? -> :SYSTEM:LCD:MODE 1;
 BRIGHTNESS 1;AUTO:MODE 0;TIME 1

:SYSTEM:LCD:AUTO?

Function Queries all settings related to the LCD backlight auto-off function.
 Syntax :SYSTEM:LCD:AUTO?
 Example :SYSTEM:LCD:AUTO? ->
 :SYSTEM:LCD:AUTO:MODE 0;TIME 1

:SYSTEM:LCD:AUTO:MODE

Function Turns the LCD backlight ON/OFF or queries the current setting.
 Syntax :SYSTEM:LCD:AUTO:MODE {<Boolean>}
 :SYSTEM:LCD:AUTO:MODE?
 Example :SYSTEM:LCD:AUTO:MODE ON
 :SYSTEM:LCD:AUTO:MODE? ->
 :SYSTEM:LCD:AUTO:MODE 1

5.28 SYSTem Group

:SYSTem:LCD:AUTO:TIME

Function Sets the time for the LCD backlight to automatically turn OFF or queries the current setting.

Syntax :SYSTem:LCD:AUTO:TIME {<NRf>}
:SYSTem:LCD:AUTO:TIME?
<NRf>=1 to 60 (minute)

Example :SYSTEM:LCD:AUTO:TIME 1
:SYSTEM:LCD:AUTO:TIME? ->
:SYSTEM:LCD:AUTO:TIME 1

:SYSTem:LCD:BRIGhtness

Function Sets/queries the brightness of the screen.

Syntax :SYSTem:LBRightness{<NRf>}
:SYSTem:LBRightness?
<NRf>=1 to 4

Example :SYSTEM:LCD:BRIGTHNESS 2
:SYSTEM:LCD:BRIGTHNESS? ->
:SYSTEM:LCD:BRIGTHNESS 2

:SYSTem:LCD:MODE

Function Turns the LCD backlight ON/OFF or queries the current setting.

Syntax :SYSTem:LCD:MODE {<Boolean>}
:SYSTem:LCD:MODE?

Example :SYSTEM:LCD:MODE OFF
:SYSTEM:LCD:MODE? ->
:SYSTEM:LCD:MODE 0

:SYSTem:MLANguage

Function Sets the menu language or queries the current setting.

Syntax :SYSTem:MLANguage {ENGLISH|CHINESE}
:SYSTem:MLANguage?

Example :SYSTEM:MLANGUAGE ENGLISH
:SYSTEM:MLANGUAGE? ->
:SYSTEM:MLANGUAGE ENGLISH

:SYSTem:OCANcel (Offset Cancel)

Function Sets whether or not to reflect the offset voltage to the measured results or the computed results (ON/OFF) or queries the current setting.

Syntax :SYSTem:OCANcel {<Boolean>}
:SYSTem:OCANcel?

Example :SYSTEM:OCANCEL ON
:SYSTEM:OCANCEL? ->
:SYSTEM:OCANCEL 0

:SYSTem:OVERview

Function Displays the system information.

Syntax :SYSTem:OVERview

Example :SYSTEM:OVERVIEW

:SYSTem:SINFormation

Function Displays the setting parameters of the device.

Syntax :SYSTem:SINFormation

Example :SYSTEM:SINFORMATION

:SYSTem:TGATe (Trigger Gate)

Function Sets the external trigger gate or queries the current setting.

Syntax :SYSTem:TGATe {<OFF|HIGH|LOW>}
:SYSTem:TGATe?

Example :SYSTEM:TGATE OFF
:SYSTEM:TGATE? -> :SYSTEM:TGATE 0

:SYSTem:USBKeyboard

Function Sets the USB keyboard type or queries the current setting.

Syntax :SYSTem:USBKeyboard
{ENGLISH|JAPANESE}
:SYSTem:USBKeyboard?

Example :SYSTEM:USBKEYBOARD ENGLISH
:SYSTEM:USBKEYBOARD? ->
:SYSTEM:USBKEYBOARD ENGLISH

5.29 TIMEbase Group

The commands in the TIMEbase group are used to make settings and queries about the time base. These settings and inquiries can also be made using TIME/DIV on the front panel.

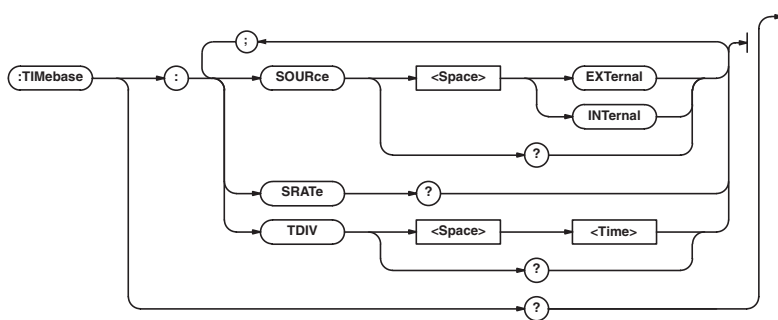

:TIMEbase?

Function Queries all the time base settings.

Syntax :TIMEbase?

Example :TIMEBASE? -> :TIMEBASE:SOURCE
INTERNAL;TDIV 500.0E-06

:TIMEbase:SOURCE

Function Sets the time base or queries the current setting.

Syntax :TIMEbase:SOURCE
{EXTERNAL|INTERNAL}

Example :TIMEBASE:SOURCE INTERNAL
:TIMEBASE:SOURCE? ->
:TIMEBASE:SOURCE INTERNAL

:TIMEbase:SRATE? (Sample RATE)

Function Queries the sampling rate.

Syntax :TIMEbase:SRATE?

Example :TIMEBASE:SRATE? ->
:TIMEBASE:SRATE 1.0E+09

:TIMEbase:TDIV

Function Sets/queries the T/div setting.

Syntax :TIMEbase:TDIV {<Time>}
:TIMEbase:TDIV?
<Time>=1 ns to 50 s

Example :TIMEBASE:TDIV 1MS
:TIMEBASE:TDIV? ->
:TIMEBASE:TDIV 1.000E-03

5.30 TRIGger Group

5.30 TRIGger Group

The commands in the TRIGger group are used to make settings and queries about the trigger. The same settings can be made using the TRIGGER group keys (SIMPLE and ENHANCED, and LEVEL nob, and POSITION/DELAY).

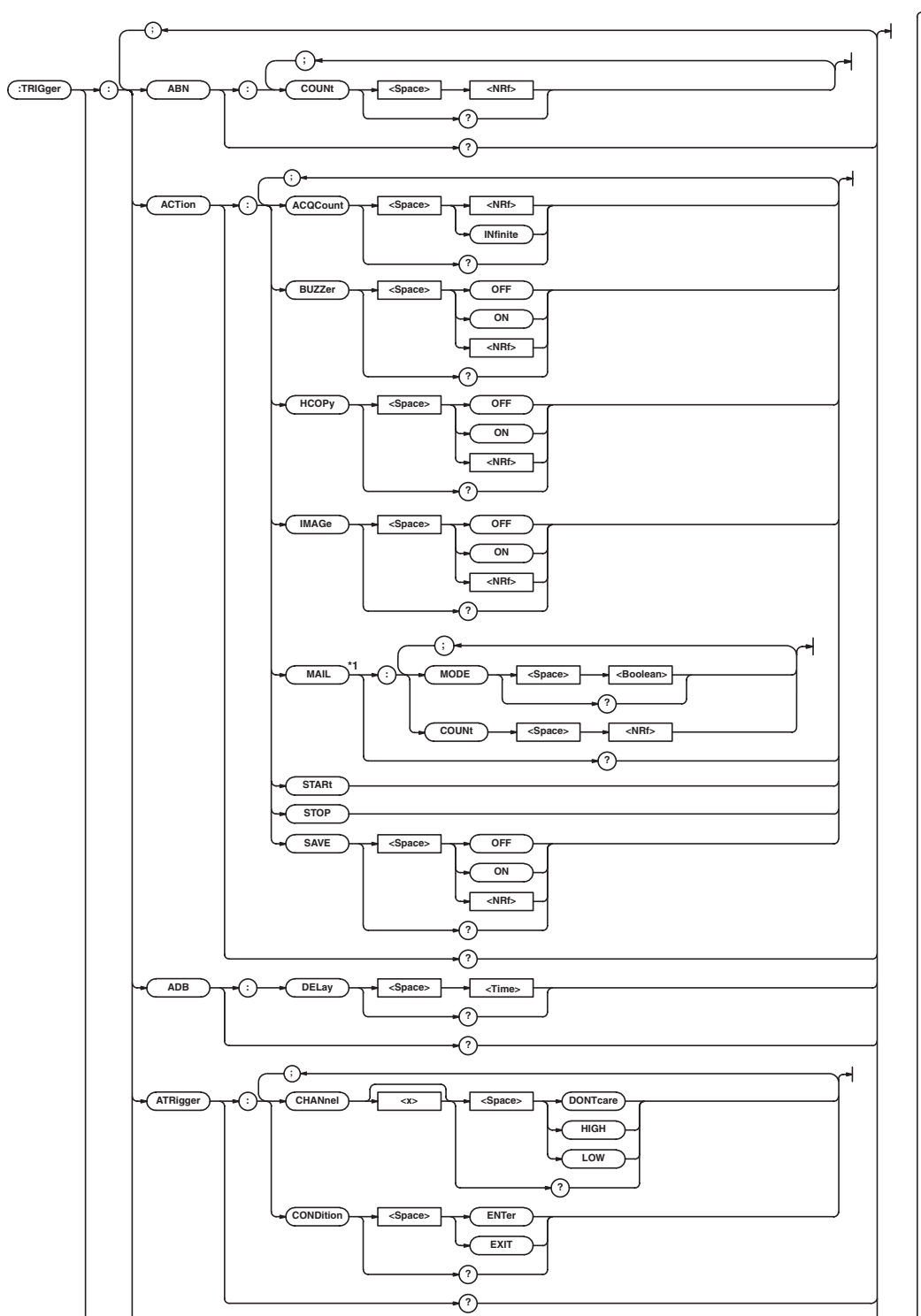

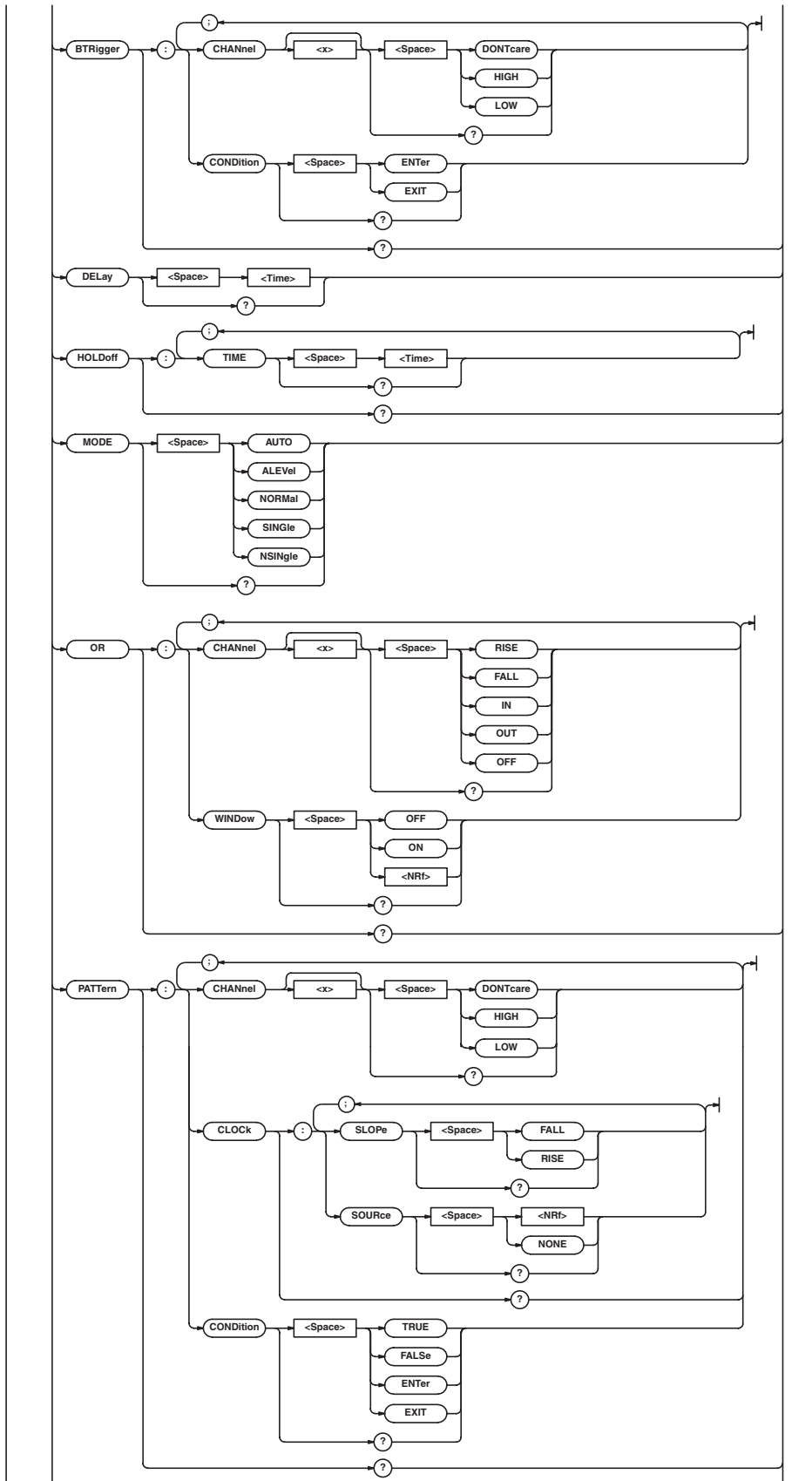

5.30 TRIGger Group

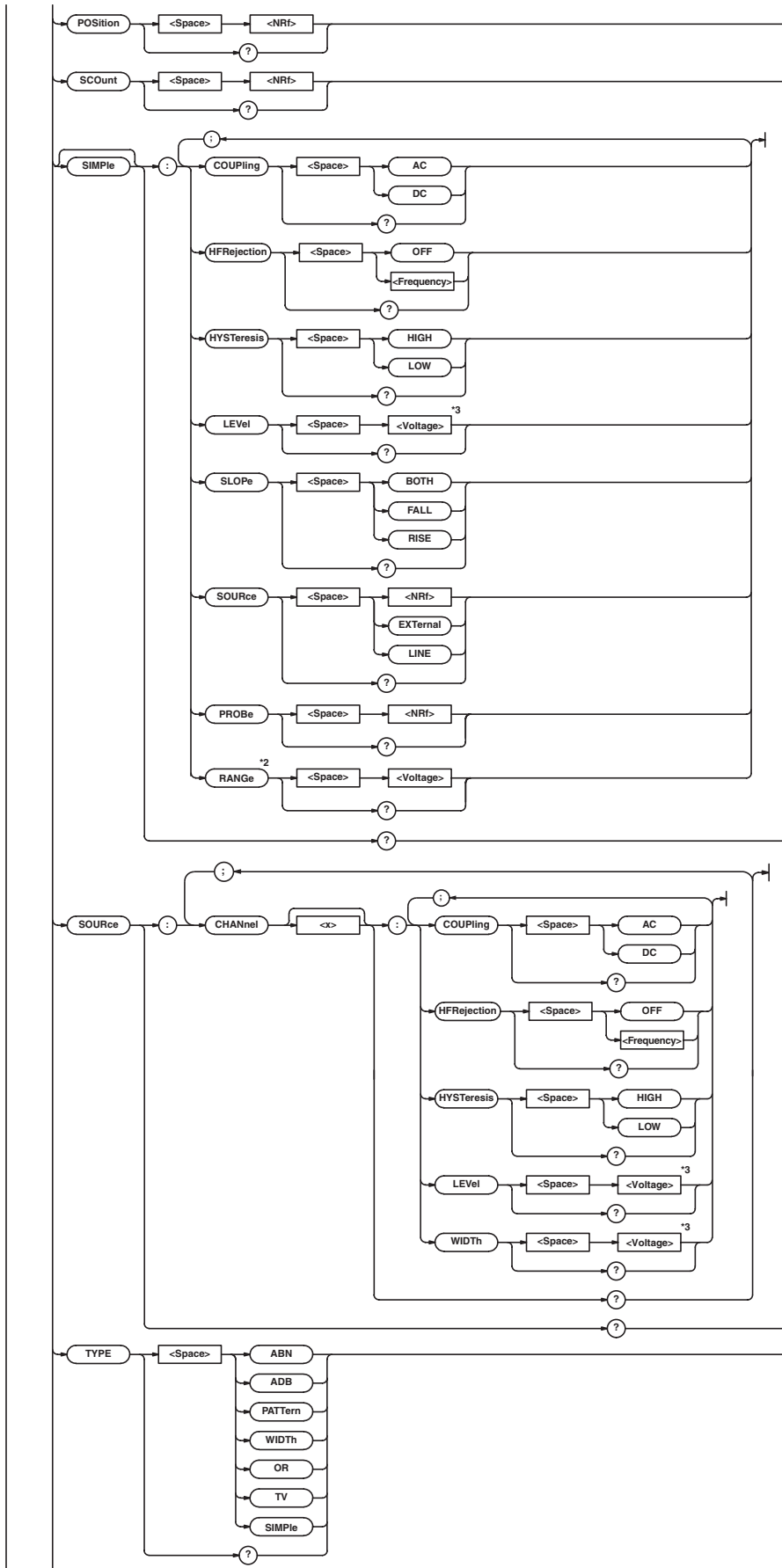

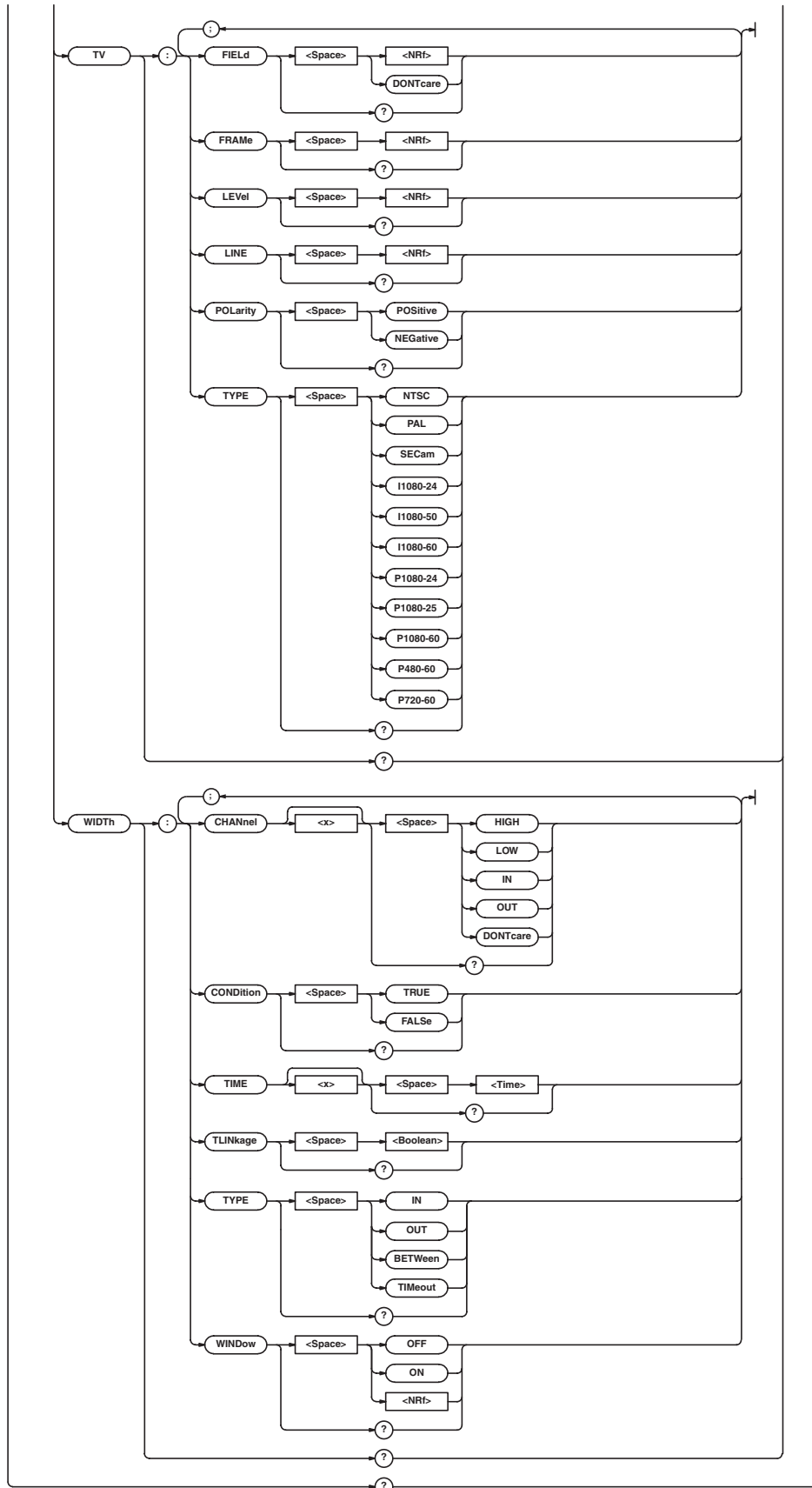

- *1 Can be used when the Ethernet interface (option) is installed.
- *2 For use on the DL1720E.
- *3 When the target channel is set to the current probe, becomes <Current>.

5.30 TRIGger Group

:TRIGger?

Function Queries all trigger settings.
Syntax :TRIGger?
Example :TRIGGER? -> :TRIGGER:ACTION:
BUZZER 0;SAVE 0;HCOPY 0;IMAGE 0;
ACQCOUNT INFINITE;:TRIGGER:SIMPLE:
SOURCE 1;LEVEL 0.0E+00;SLOPE RISE;
COUPLING DC;HFREJECTION OFF;
HYSTERESIS LOW;PROBE 1;:TRIGGER:
SOURCE:CHANNEL1:LEVEL 0.0E+00;
COUPLING DC;HFREJECTION OFF;
HYSTERESIS LOW;WIDTH 500.000E-03;:
TRIGGER:SOURCE:CHANNEL2:
LEVEL 0.0E+00;COUPLING DC;
HFREJECTION OFF;HYSTERESIS LOW;
WIDTH 50.000E+00;:TRIGGER:SOURCE:
CHANNEL3:LEVEL 0.0E+00;COUPLING DC;
HFREJECTION OFF;HYSTERESIS LOW;
WIDTH 1.000E+00;:TRIGGER:SOURCE:
CHANNEL4:LEVEL 0.0E+00;COUPLING DC;
HFREJECTION OFF;HYSTERESIS LOW;
WIDTH 50.000E+00;:TRIGGER:ABN:
COUNT 1;:TRIGGER:HOLDOFF:
TIME 80.000E-09;:TRIGGER:ADB:
DELAY 1.000E-09;:TRIGGER:
DELAY 0.0E+00;PATTERN:CLOCK:
SOURCE 1;SLOPE RISE;:TRIGGER:
PATTERN:CHANNEL1 HIGH;
CHANNEL2 DONTCARE;
CHANNEL3 DONTCARE;
CHANNEL4 DONTCARE;CONDITION TRUE;:
TRIGGER:POSITION 50.000;MODE AUTO;
WIDTH:TYPE IN;CHANNEL1 HIGH;
CHANNEL2 HIGH;CHANNEL3 HIGH;
CHANNEL4 HIGH;CONDITION TRUE;
TLINKAGE 0;TIME1 1.000E-09;
TIME2 1.000E-09;WINDOW 0;:TRIGGER:
OR:WINDOW 0;CHANNEL1 RISE;
CHANNEL2 OFF;CHANNEL3 OFF;
CHANNEL4 OFF;:TRIGGER:SCOUNT 2;TV:
TYPE NTSC;POLARITY NEGATIVE;
LEVEL 5000000.0;FIELD 1;LINE 5;
FRAME 1;:TRIGGER:TYPE SIMPLE;
ATRIGGER:CHANNEL1 HIGH;
CHANNEL2 DONTCARE;
CHANNEL3 DONTCARE;
CHANNEL4 DONTCARE;
CONDITION ENTER;:TRIGGER:BTRIGGER:
CHANNEL1 DONTCARE;CHANNEL2 HIGH;
CHANNEL3 DONTCARE;
CHANNEL4 DONTCARE;CONDITION ENTER

:TRIGger:ABN? (A -> B (n))

Function Queries all A -> B (n) trigger settings.
Syntax :TRIGger:ABN?
Example :TRIGGER:ABN? ->
:TRIGGER:ABN:COUNT 1

:TRIGger:ABN:COUNT

Function Sets/queries the number of times the pattern for the A -> B (n) trigger should become true.
Syntax :TRIGger:ABN:COUNT {<NRf>}
:TRIGger:ABN:COUNT?
<NRf>=1 to 100000000
Example :TRIGGER:ABN:COUNT 1
:TRIGGER:ABN:COUNT? ->
:TRIGGER:ABN:COUNT 1

:TRIGger:ACTion?

Function Queries all settings relating to the action on trigger.
Syntax :TRIGger:ACTion?
Example :TRIGGER:ACTION? ->
:TRIGGER:ACTION:BUZZER 0;SAVE 0;
HCOPY 0;IMAGE 0;ACQCOUNT INFINITE

:TRIGger:ACTion:ACQCount

Function Sets the number of times to perform the action for the action-on-trigger or queries the current setting.
Syntax :TRIGger:ACTion:ACQCount
{<NRf|INFinite>}
:TRIGger:ACTion:ACQCount?
<NRf>=1 to 65536
Example :TRIGGER:ACTION:ACQCOUNT 10
:TRIGGER:ACTION:ACQCOUNT? ->
:TRIGGER:ACTION:ACQCOUNT 10

:TRIGger:ACTion:BUZZer

Function Sets/queries the ON/OFF condition of the buzzer at the time of the trigger action.
Syntax :TRIGger:ACTion:BUZZer {<Boolean>}
:TRIGger:ACTion:BUZZer?
Example :TRIGGER:ACTION:BUZZER ON
:TRIGGER:ACTION:BUZZER? ->
:TRIGGER:ACTION:BUZZER 1

:TRIGger:ACTion:HCOPY

Function Sets/queries whether the screen image data is output at the time of the trigger action.
Syntax :TRIGger:ACTion:HCOPY {<Boolean>}
:TRIGger:ACTion:HCOPY?
Example :TRIGGER:ACTION:HCOPY ON
:TRIGGER:ACTION:HCOPY? ->
:TRIGGER:ACTION:HCOPY 1

:TRIGger:ACTion:IMAGE

Function Sets whether or not to save the screen image to the external storage medium when action is activated or queries the current setting.
Syntax :TRIGger:ACTion:IMAGE {<Boolean>}
:TRIGger:ACTion:IMAGE?
Example :TRIGGER:ACTION:IMAGE ON
:TRIGGER:ACTION:IMAGE ->
:TRIGGER:ACTION:IMAGE 1

:TRIGger:ACTion:MAIL?

Function Queries all the setting values for mail reports sent as an ACTION.
Syntax :TRIGger:ACTion:MAIL?
Example :TRIGGER:ACTION:MAIL:MODE? ->
:TRIGGER:ACTION:MAIL:MODE 0;
COUNT 100
Description Can be used when the Ethernet interface (option) is installed.

:TRIGger:ACTion:MAIL:COUNT

Function Sets/queries the limit for the number of reports that are sent as an ACTION.

Syntax :TRIGger:ACTion:MAIL:COUNT {<Nrf>}
:TRIGger:ACTion:MAIL:COUNT?
<Nrf>=1 to 1000

Example :TRIGGER:ACTION:MAIL:COUNT 100
:TRIGGER:ACTION:MAIL:COUNT? ->
:TRIGGER:ACTION:MAIL:COUNT 100

Description Can be used when the Ethernet interface (option) is installed.

:TRIGger:ACTion:MAIL:MODE

Function Sets/queries whether mail reports are sent as an ACTION.

Syntax :TRIGger:ACTion:MAIL:MODE
{<Boolean>}

Example :TRIGGER:ACTION:MAIL:MODE OFF
:TRIGGER:ACTION:MAIL:MODE? ->
:TRIGGER:ACTION:MAIL:MODE 0

Description Can be used when the Ethernet interface (option) is installed.

:TRIGger:ACTion:SAVE

Function Sets/queries whether the waveform data is saved to the medium at the time of the trigger action.

Syntax :TRIGger:ACTion:SAVE {<Boolean>}

Example :TRIGGER:ACTION:SAVE ON
:TRIGGER:ACTION:SAVE? ->
:TRIGGER:ACTION:SAVE 1

:TRIGger:ACTion:START

Function Starts action-on-trigger.

Syntax :TRIGger:ACTion:START

Example :TRIGGER:ACTION:START

Description Use :TRIGger:ACTion:STOP to abort the trigger action.

:TRIGger:ACTion:STOP

Function Aborts action-on-trigger.

Syntax :TRIGger:ACTion:STOP

Example :TRIGGER:ACTION:STOP

Description This command only aborts the trigger action. It does not cancel the settings. The :TRIGger:ACTion:START command can be used to resume the trigger action.

:TRIGger:ADB? (A Delay B)

Function Queries all A Delay B trigger settings.

Syntax :TRIGger:ADB?

Example :TRIGGER:ADB? ->
:TRIGGER:ADB:DELAY 0.000E+00

:TRIGger:ADB:DELAY

Function Sets/queries the delay time for pattern B for an A Delay B trigger.

Syntax :TRIGger:ADB:DELAY {<Time>}
:TRIGger:ADB:DELAY?
<Time>=3 ns to 5 s

Example :TRIGGER:ADB:DELAY 1NS
:TRIGGER:ADB:DELAY? ->
:TRIGGER:ADB:DELAY 1.0E-09

:TRIGger:ATRigger?

Function Queries all the pattern A settings.

Syntax :TRIGger:ATRigger?

Example :TRIGGER:ATRIGGER? ->
:TRIGGER:ATRIGGER:CHANNEL1 HIGH;
CHANNEL2 DONTCARE;
CHANNEL3 DONTCARE;
CHANNEL4 DONTCARE;CONDITION ENTER

:TRIGger:ATRigger:CHANnel<x>

Function Sets/queries the channel condition for pattern A.

Syntax :TRIGger:ATRigger:CHANnel<x>
{DONTcare | HIGH | LOW}
:TRIGger:ATRigger:CHANnel<x>?
<x>=1 to 4 (1 to 2 on the DL1720E)

Example (An example for CH1 is given below.)
:TRIGGER:ATRIGGER:CHANNEL1 HIGH
:TRIGGER:ATRIGGER:CHANNEL1? ->
:TRIGGER:ATRIGGER:CHANNEL1 HIGH

:TRIGger:ATRigger:CONDition

Function Sets/queries the conditions under which pattern A should become true.

Syntax :TRIGger:ATRigger:CONDition
{ENTER | EXIT}
:TRIGger:ATRigger:CONDition?

Example :TRIGGER:ATRIGGER:CONDITION ENTER
:TRIGGER:ATRIGGER:CONDITION? ->
:TRIGGER:ATRIGGER:CONDITION ENTER

Description This command is valid when the trigger type is "ABN" or "ADB."

:TRIGger:BTRigger?

Function Queries all pattern B settings.

Syntax :TRIGger:BTRigger?

Example :TRIGGER:BTRIGGER? ->
:TRIGGER:BTRIGGER:
CHANNEL1 DONTCARE;
CHANNEL2 HIGH;CHANNEL3 DONTCARE;
CHANNEL4 DONTCARE;CONDITION ENTER

:TRIGger:BTRigger:CHANnel<x>

Function Sets/queries the channel condition for pattern B.

Syntax :TRIGger:BTRigger:CHANnel<x>
{DONTcare | HIGH | LOW}
:TRIGger:BTRigger:CHANnel<x>?
<x>=1 to 4 (1 to 2 on the DL1720E)

Example (An example for CH1 is given below.)
:TRIGGER:BTRIGGER:CHANNEL1 HIGH
:TRIGGER:BTRIGGER:CHANNEL1? ->
:TRIGGER:BTRIGGER:CHANNEL1 HIGH

:TRIGger:BTRigger:CONDition

Function Sets/queries the conditions under which pattern B becomes true.

Syntax :TRIGger:BTRigger:CONDition
{ENTER | EXIT}
:TRIGger:BTRigger:CONDition?

Example :TRIGGER:BTRIGGER:CONDITION ENTER
:TRIGGER:BTRIGGER:CONDITION? ->
:TRIGGER:BTRIGGER:CONDITION ENTER

Description This command is valid when the trigger type is "ABN" or "ADB."

5.30 TRIGger Group

:TRIGger:DElay

Function Sets/queries the trigger delay (time between trigger point and trigger position).

Syntax :TRIGger:DElay {<Time>}
:TRIGger:DElay?

Example <Time>=0 to 4 s (1/sampling rate steps)
:TRIGGER:DElay 2US
:TRIGGER:DElay? -> :TRIGGER:DElay
2.00E-06

Description If timebase is external clock, the value is fixed at 0.
On this oscilloscope, the delay is the time difference between the trigger point and the trigger position. You can set/query the trigger position using the ":TRIGger:POSition" command.

:TRIGger:HOLDOff?

Function Queries all settings related to the hold off.

Syntax :TRIGger:HOLDOff?

Example :TRIGGER:HOLDOFF? ->
:TRIGGER:HOLDOFF:TIME 80.0E-09

:TRIGger:HOLDOff:TIME

Function Sets the hold off time or queries the current setting.

Syntax :TRIGger:HOLDOff:TIME {<time>}
:TRIGger:HOLDOff:TIME?

Example <time>=80 ns to 10 s
:TRIGGER:HOLDOFF:TIME 80NS
:TRIGGER:HOLDOFF:TIME? ->
:TRIGGER:HOLDOFF:TIME 80.0E-09

:TRIGger:MODE

Function Sets the trigger mode or queries the current setting.

Syntax :TRIGger:MODE
{AUTO|ALEvel|NORMAL|SINGLE|NSINGLE}

Example :TRIGGER:MODE AUTO
:TRIGGER:MODE? ->
:TRIGGER:MODE AUTO

Description Use the ":TRIGger:SCOUNT" command to query the count when "NSINGLE" is selected.

:TRIGger:OR?

Function Queries all settings related to the OR trigger.

Syntax :TRIGger:OR?

Example :TRIGGER:OR? -> :TRIGGER:OR:
WINDOW 0;CHANNEL1 OFF;CHANNEL2 OFF;
CHANNEL3 OFF;CHANNEL4 OFF

:TRIGger:OR:CHANnel<x>

Function Sets the edge of the OR trigger of each channel or queries the current setting.

Syntax :TRIGger:OR:CHANnel<x>
{OFF|RISE|FALL|IN|OUT}
:TRIGger:OR:CHANnel<x>?

Example <x>=1 to 4 (1 to 2 on the DL1720E)
(The following example is for CH1.)
:TRIGGER:OR:CHANNEL1 RISE
:TRIGGER:OR:CHANNEL1? ->
:TRIGGER:OR:CHANNEL1 RISE

Description Select from {IN|OUT} when
":TRIGger:OR:WINDow ON" is specified and
from {FALL|RISE}, otherwise.

:TRIGger:OR:WINDow

Function Turns the OR trigger window ON/OFF or queries the current setting.

Syntax :TRIGger:OR:WINDow {<Boolean>}
:TRIGger:OR:WINDow?

Example :TRIGGER:OR:WINDow ON
:TRIGGER:OR:WINDow? ->
:TRIGGER:OR:WINDow 1

:TRIGger:PATtern?

Function Queries all settings related to the pattern trigger.

Syntax :TRIGger:PATtern?

Example :TRIGGER:PATTERN? -> :TRIGGER:
PATTERN:CLOCK:SOURCE NONE;;
TRIGGER:PATTERN:CHANNEL1 HIGH;
CHANNEL2 DONTCARE;
CHANNEL3 DONTCARE;
CHANNEL4 DONTCARE;CONDITION ENTER

:TRIGger:PATtern:CHANnel<x>

Function Sets the status of each channel when using the pattern trigger or queries the current setting.

Syntax :TRIGger:PATtern:
CHANnel<x> {DONTcare|HIGH|LOW}
:TRIGger:PATtern:CHANnel<x>?

Example <x>=1 to 4 (1 to 2 on the DL1720E)
:TRIGGER:PATTERN:CHANNEL1 DONTCARE
:TRIGGER:PATTERN:CHANNEL1? ->
:TRIGGER:PATTERN:CHANNEL1 DONTCARE

:TRIGger:PATtern:CLOCK?

Function Queries all settings related to the clock channel when using the pattern trigger.

Syntax :TRIGger:PATtern:CLOCK?

Example :TRIGGER:PATTERN:CLOCK? ->
:TRIGGER:PATTERN:CLOCK:SOURCE 1;
SLOPE RISE

:TRIGger:PATtern:CLOCK:SLOPE

Function Sets the slope of the clock channel when using the pattern trigger or queries the current setting.

Syntax :TRIGger:PATtern:CLOCK:
SLOPE {FALL|RISE}

Example :TRIGGER:PATTERN:CLOCK:SLOPE RISE
:TRIGGER:PATTERN:CLOCK:SLOPE? ->
:TRIGGER:SIMPLE:PATTERN:CLOCK:
SLOPE RISE

Description An error results if
":TRIGger:PATtern:CLOCK:SOURce NONE"
is specified.

:TRIGger:PATtern:CLOCK:SOURce

Function Sets the clock channel when using the pattern trigger or queries the current setting.

Syntax :TRIGger:PATtern:CLOCK:
SOURce {<NRF>|NONE}

Example :TRIGGER:PATTERN:CLOCK:SOURCE?
<x>=1 to 4 (1 to 2 on the DL1720E)
:TRIGGER:PATTERN:CLOCK:SOURCE 1
:TRIGGER:PATTERN:CLOCK:SOURCE? ->
:TRIGGER:PATTERN:CLOCK:SOURCE 1

:TRIGger:PATtern:CONDition

Function Sets the trigger condition when using the pattern trigger or queries the current setting.

Syntax `:TRIGger:PATtern:CONDition {ENTER|EXIT|FALSE|TRUE}`
`:TRIGger:PATtern:CONDition?`

Example `:TRIGGER:PATTERN:CONDITION ENTER`
`:TRIGGER:PATTERN:CONDITION? ->`
`:TRIGGER:PATTERN:CONDITION ENTER`

Description Select the condition from {ENTER|EXIT} when “:TRIGger:PATtern:CLOCK:SOURce NONE” is specified and from {FALSE|TRUE}, otherwise.

:TRIGger:POSition

Function Sets the trigger position or queries the current setting.

Syntax `:TRIGger:POSition {<Nrf>}`
`:TRIGger:POSition?`
`<Nrf>=0 to 100 (% , 0.1 steps)`

Example `:TRIGGER:POSITION 50`
`:TRIGGER:POSITION? ->`
`:TRIGGER:POSITION 50.000`

:TRIGger:SCount (Single (N) Count)

Function Sets the number of times the trigger is activated when the trigger mode is set to Single (N) or queries the current setting.

Syntax `:TRIGger:SCount {<Nrf>}`
`:TRIGger:SCount?`
`<Nrf>=1 to 2048`

Example `:TRIGGER:SCOUNT 100`
`:TRIGGER:SCOUNT? ->`
`:TRIGGER:SCOUNT 100`

:TRIGger[:SIMple]?

Function Queries all settings related to the simple trigger.

Syntax `:TRIGger:SIMple?`

Example `:TRIGGER:SIMPLE? ->`
`:TRIGGER:SIMPLE:SOURCE 1;`
`LEVEL 0.0E+00;SLOPE RISE;`
`COUPLING DC;HFREJECTION OFF;`
`HYSTERESIS LOW`

:TRIGger[:SIMple]:COUpling

Function Sets the trigger coupling for the simple trigger or queries the current setting.

Syntax `:TRIGger[:SIMple]:COUpling {AC|DC}`
`:TRIGger[:SIMple]:COUpling?`

Example `:TRIGGER:SIMPLE:COUPLING DC`
`:TRIGGER:SIMPLE:COUPLING? ->`
`:TRIGGER:SIMPLE:COUPLING DC`

Description Setting/Querying is not possible when the trigger source is set to “EXTernal” or “LINE.”

:TRIGger[:SIMple]:HFRejection (HighFrequencyREJECTION)

Function Turns the low-pass filter (HF rejection) for the trigger signal ON/OFF or queries the current setting.

Syntax `:TRIGger[:SIMple]:HFRejection {OFF|<Frequency>}`
`:TRIGger[:SIMple]:HFRejection?`
`<Frequency>=20 MHz, 15 kHz`

Example `:TRIGGER:SIMPLE:HFREJECTION 20MHz`
`:TRIGGER:SIMPLE:HFREJECTION? ->`
`:TRIGGER:SIMPLE:HFREJECTION`
`20.0E+06`

Description Setting/Querying is not possible when the trigger source is set to “EXTernal” or “LINE.”

:TRIGger[:SIMple]:HYSTeresis

Function Sets the hysteresis on the search level of the simple trigger or queries the current setting.

Syntax `:TRIGger[:SIMple]:HYSTeresis {HIGH|LOW}`
`:TRIGger[:SIMple]:HYSTeresis?`

Example `:TRIGGER:SIMPLE:HYSTERESIS HIGH`
`:TRIGGER:SIMPLE:HYSTERESIS? ->`
`:TRIGGER:SIMPLE:HYSTERESIS HIGH`

Description Setting/Querying is not possible when the trigger source is set to “EXTernal” or “LINE.”

:TRIGger[:SIMple]:LEVel

Function Sets the trigger level of the channel specified with the “:TRIGger[:SIMple]:SOURce” command or queries the current setting.

Syntax `:TRIGger[:SIMple]:LEVel {<voltage>}`
`:TRIGger[:SIMple]:LEVel?`
`<voltage>=See the User’s Manual.`

Example `:TRIGGER:SIMPLE:LEVEL 0V`
`:TRIGGER:SIMPLE:LEVEL? ->`
`:TRIGGER:SIMPLE:LEVEL 0.000E+00`

Description • Setting/Querying is not possible when the trigger source is set to “LINE.”
• When set to the current probe, sets the <Current> value or queries the current setting.

:TRIGger[:SIMple]:PROBE

Function Sets the probe when the trigger source is set to “EXTernal” or queries the current setting.

Syntax `:TRIGger[:SIMple]:PROBE {<Nrf>}`
`:TRIGger[:SIMple]:PROBe?`
`<Nrf>=1, 10`

Example `:TRIGGER:SIMPLE:PROBE 1`
`:TRIGGER:SIMPLE:PROBE ->`
`:TRIGGER:SIMPLE:PROBE 1`

Description Setting/Querying is not possible unless the trigger source is set to “EXTernal.”

:TRIGger[:SIMple]:RANGe

Function Sets the input range for the external trigger and queries the current setting. (DL1720E only)

Syntax `:TRIGger[:SIMple]:RANGe {<voltage>}`
`:TRIGger[:SIMple]:RANGe?`
`<Nrf>=1 to 100 V`

Example `:TRIGGER:SIMPLE:RANGE 1V`
`:TRIGGER:SIMPLE:RANGE? ->`
`:TRIGGER:SIMPLE:RANGE 1.0E+00`

Description Setting/Querying is not possible unless the trigger source is set to “EXTernal.”

5.30 TRIGger Group

:TRIGger [:SIMPlE] :SLOPe

Function Sets the trigger slope of the channel specified with the “:TRIGger[:SIMPlE]:SOURce” command or queries the current setting.

Syntax :TRIGger[:SIMPlE]:SLOPe
{BOTH|FALL|RISE}
:TRIGger[:SIMPlE]:SLOPe?

Example :TRIGGER:SIMPLE:SLOPE RISE
:TRIGGER:SIMPLE:SLOPE? ->
:TRIGGER:SIMPLE:SLOPE RISE

Description Setting/Querying is not possible when the trigger source is set to “LINE.”

:TRIGger:SIMPlE:SOURce

Function Sets the trigger source for the simple trigger or queries the current setting.

Syntax :TRIGger:SIMPlE:SOURce
{<NRf>|EXTErnal|LINE}
:TRIGger:SIMPlE:SOURce?
<NRf>=1 to 4 (1 to 2 on the DL1720E)

Example :TRIGGER:SIMPLE:SOURCE 1
:TRIGGER:SIMPLE:SOURCE? ->
:TRIGGER:SIMPLE:SOURCE 1

Description Within the :TRIGger:SIMPlE series of commands, “SIMPlE” may be omitted except in the case of the :TRIGger:SIMPlE:SOURce command.

:TRIGger:SOURce?

Function Enhanced Queries all settings related to the trigger source for the enhanced trigger.

Syntax :TRIGger:SOURce?

Example :TRIGGER:SOURCE? -> :TRIGGER:
SOURCE:CHANNEL1:LEVEL 0.0E+00;
COUPLING DC;HFREJECTION OFF;
HYSTERESIS HIGH;CENTER0.0E+00;
WIDTH 2.000E+00;;:TRIGGER:SOURCE:
CHANNEL2:LEVEL 0.0E+00;COUPLING DC;
HFREJECTION OFF;HYSTERESIS HIGH;
CENTER 0.0E+00;WIDTH 20.000E+00;;
TRIGGER:SOURCE:CHANNEL3:
LEVEL 0.0E+00;COUPLING DC;
HFREJECTION OFF;HYSTERESIS HIGH;
CENTER 0.0E+00;WIDTH 2.000E+00;;
TRIGGER:SOURCE:CHANNEL4:
LEVEL 0.0E+00;COUPLING DC;
HFREJECTION OFF;HYSTERESIS HIGH;
CENTER 0.0E+00;WIDTH 50.000E+00

:TRIGger:SOURce:CHANnel<x>?

Function Queries all settings related to the trigger source of the enhanced trigger of the specified channel.

Syntax :TRIGger:SOURce:CHANnel<x>?
<x>=1 to 4 (1 to 2 on the DL1720E)

Example :TRIGGER:SOURCE:CHANNEL1? ->
:TRIGGER:SOURCE:CHANNEL1:
LEVEL 0.0E+00;COUPLING DC;
HFREJECTION OFF;HYSTERESIS LOW;
CENTER 0.0E+00;WIDTH 2.000E+00

:TRIGger:SOURce:CHANnel<x>:COUPLing

Function Sets the trigger coupling of each channel when using the enhanced trigger or queries the current setting.

Syntax :TRIGger:SOURce:CHANnel<x>:COUPLing
{AC|DC}
:TRIGger:SOURce:CHANnel<x>:
:COUPLing?

<x>=1 to 4 (1 to 2 on the DL1720E)

Example :TRIGGER:SOURCE:CHANNEL1:
COUPLING DC
:TRIGGER:SOURCE:CHANNEL1:
COUPLING? -> :TRIGGER:SOURCE:
CHANNEL1:COUPLING DC

:TRIGger:SOURce:CHANnel<x>:HFRejection (HighFREQUENCYREJECTION)

Function Sets the HF rejection on the trigger waveform for enhanced trigger or queries the current setting.

Syntax :TRIGger:SOURce:CHANnel<x>:
HFRejection {OFF|<Frequency>}
:TRIGger:SOURce:CHANnel<x>:
HFRejection?

<x>=1 to 4 (1 to 2 on the DL1720E)

<Frequency>=20 MHz or 15 kHz

Example TRIGGER:SOURCE:CHANNEL1:
HFREJECTION 15KHZ
:TRIGGER:SOURCE:CHANNEL1:
HFREJECTION? -> :TRIGGER:SOURCE:
CHANNEL1:HFREJECTION 15.0E+03

:TRIGger:SOURce:CHANnel<x>:HYSTEResis

Function Sets the hysteresis on the search level when using the enhanced trigger or queries the current setting.

Syntax :TRIGger:SOURce:CHANnel<x>:
HYSTEResis {HIGH|LOW}
:TRIGger:SOURce:CHANnel<x>:
HYSTEResis?

<x>=1 to 4 (1 to 2 on the DL1720E)

Example :TRIGGER:SOURCE:CHANNEL1:
HYSTERESIS HIGH
:TRIGGER:SOURCE:CHANNEL1:
HYSTERESIS? -> :TRIGGER:SOURCE:
CHANNEL1:HYSTERESIS HIGH

:TRIGger:SOURce:CHANnel<x>:LEVel

Function Sets the trigger level of each channel when using the enhanced trigger or queries the current setting.

Syntax :TRIGger:SOURce:CHANnel<x>:LEVel
{<voltage>}
:TRIGger:SOURce:CHANnel<x>:LEVel?
<x>=1 to 4 (1 to 2 on the DL1720E)

<voltage>=See the User’s Manual.

Example :TRIGGER:SOURCE:CHANNEL1:LEVEL 0V
:TRIGGER:SOURCE:CHANNEL1:LEVEL? ->
:TRIGGER:SOURCE:CHANNEL1:
LEVEL 0.000E+00

Description When set to the current probe, sets the <Current> value or queries the current setting.

:TRIGger:SOURce:CHANnel<x>:WIDTh

Function	Sets the width of the window trigger or queries the current setting.
Syntax	:TRIGger:SOURce:CHANnel<x>:WIDTh {<voltage>} :TRIGger:SOURce:CHANnel<x>:WIDTh? <x>=1 to 4 (1 to 2 on the DL1720E) <voltage>=one to eight times V/div (1/100 of V/div steps)
Example	:TRIGGER:SOURCE:CHANNEL1:WIDTH 5V :TRIGGER:SOURCE:CHANNEL1:WIDTH? -> :TRIGGER:SOURCE:CHANNEL1: WIDTH 5.0E+00
Description	When set to the current probe, sets the <Current> value or queries the current setting.

:TRIGger:TV?

Function	Queries all settings related to the TV trigger.
Syntax	:TRIGger:TV?
Example	:TRIGGER:TV? -> :TRIGGER:TV: TYPE NTSC;POLARITY NEGATIVE; LEVEL 0.5;FIELD 1;LINE 5;FRAME 1
Description	The trigger source for the TV trigger is fixed to CH1.

:TRIGger:TV:FIELD

Function	Sets the field on which to activate the TV trigger or queries the current setting.
Syntax	:TRIGger:TV:FIELD {DONTcare <NRf>} :TRIGger:TV:FIELD? <NRf>=1 or 2
Example	:TRIGGER:TV:FIELD DONTCARE :TRIGGER:TV:FIELD? -> :TRIGGER:TV:FIELD DONTCARE

:TRIGger:TV:FRAME

Function	Sets the frame skip function of the TV trigger or queries the current setting.
Syntax	:TRIGger:TV:FRAME {<NRf>} :TRIGger:TV:FRAME? <NRf>=1, 2, 4, or 8
Example	:TRIGGER:TV:FRAME 2 :TRIGGER:TV:FRAME? -> :TRIGGER:TV:FRAME 2

:TRIGger:TV:LEVEL

Function	Sets the trigger level of the TV trigger or queries the current setting.
Syntax	:TRIGger:TV:LEVEL {<NRf>} :TRIGger:TV:LEVEL? <NRf>=0.1 to 2 div (0.1 div steps)
Example	:TRIGGER:TV:LEVEL 0.1 :TRIGGER:TV:LEVEL? -> :TRIGGER:TV:LEVEL 0.1

:TRIGger:TV:LINE

Function	Sets the line on which to activate the TV trigger or queries the current setting.
Syntax	:TRIGger:TV:LINE {<NRf>} :TRIGger:TV:LINE? <NRf>=5 to 1054 (for NTSC) 2 to 1251 (for PAL or SECAM) 2 to 2251 (other than NTSC, PAL or SECAM) 8 to 2251 (for 480-60P)
Example	:TRIGGER:TV:LINE 5 :TRIGGER:TV:LINE? -> :TRIGGER:TV:LINE 5

:TRIGger:TV:POLarity

Function	Sets the TV trigger's input polarity or queries the current setting.
Syntax	:TRIGger:TV:POLarity {POSitive NEGative}
Example	:TRIGGER:TV:POLARITY POSITIVE :TRIGGER:TV:POLARITY? -> :TRIGGER:TV:POLARITY POSITIVE

:TRIGger:TV:TYPE

Function	Sets the TV trigger's input type or queries the current setting.
Syntax	:TRIGger:TV:TYPE {NTSC PAL SECAM SF1080-24 I1080-50 I1080-60 P1080-24 P1080-25 P1080-60 P480-60 P720-60}
Example	:TRIGGER:TV:TYPE? :TRIGGER:TV:TYPE NTSC :TRIGGER:TV:TYPE? -> :TRIGGER:TV:TYPE NTSC
Description	The trigger source for the TV trigger is fixed to CH1.

:TRIGger:TYPE

Function	Sets the trigger type or queries the current setting.
Syntax	:TRIGger:TYPE {ABN ADB PATTERN WIDTh OR TV SIMple}
Example	:TRIGGER:TYPE? :TRIGGER:TYPE SIMPLE:TRIGGER: TYPE? -> :TRIGGER:TYPE SIMPLE

:TRIGger:WIDTh?

Function	Queries all settings related to the pulse width trigger.
Syntax	:TRIGger:WIDTh?
Example	:TRIGGER:WIDTH? -> :TRIGGER:WIDTH: TYPE IN;CHANNEL1 HIGH; CHANNEL2 HIGH;CHANNEL3 HIGH; CHANNEL4 HIGH;CONDITION TRUE; TLINKAGE 0;TIME1 1.0E-09; TIME2 2.0E-09;WINDOW 0

:TRIGger:WIDTh:CHANnel<x>

Function	Sets the trigger condition of each channel when using the pulse width trigger or queries the current setting.
Syntax	:TRIGger:WIDTh:CHANnel<x> {HIGH LOW IN OUT DONTcare} :TRIGger:WIDTh:CHANnel<x>? <x>=1 to 4 (1 to 2 on the DL1720E)
Example	:TRIGGER:WIDTH:CHANNEL1 IN :TRIGGER:WIDTH:CHANNEL1? -> :TRIGGER:WIDTH:CHANNEL1 IN
Description	Select from {IN OUT} when ":TRIGGER:OR:WINDOW ON" is specified and from {FALL RISE}, otherwise.

5.30 TRIGger Group

:TRIGger:WIDTh:CONDition

Function Sets the trigger condition when using the pulse width trigger or queries the current setting.

Syntax :TRIGger:WIDTh:CONDition
{TRUE|FALSe}

Example :TRIGger:WIDTh:CONDition?
:TRIGGER:WIDTH:CONDITION TRUE
:TRIGGER:WIDTH:CONDITION? ->
:TRIGGER:WIDTH:CONDITION TRUE

:TRIGger:WIDTh:TIME<x>

Function Sets the pulse width when using the pulse width trigger or queries the current setting.

Syntax :TRIGger:WIDTh:TIME<x> <time>
:TRIGger:WIDTh:TIME<x>?
<x>=1 or 2
<time>= 1 ns to 1 s

Example See the User's Manual.
:TRIGGER:WIDTH:TIME1 10NS
:TRIGGER:WIDTH:TIME1? ->
:TRIGGER:WIDTH:TIME1 10.0E-09

:TRIGger:WIDTh:TLINKage

Function Turns the link ON/OFF when changing the pulse width for the pulse width trigger or queries the current setting.

Syntax :TRIGger:WIDTh:TLINKage {<Boolean>}
:TRIGger:WIDTh:TLINKage?

Example :TRIGGER:WIDTH:TLINKAGE ON
:TRIGGER:WIDTH:TLINKAGE? ->
:TRIGGER:WIDTH:TLINKAGE 1

:TRIGger:WIDTh:TYPE

Function Sets the criteria type when using the pulse width trigger or queries the current setting.

Syntax :TRIGger:WIDTh:TYPE
{IN|OUT|BETWEEen|TIMEout}

Example :TRIGGER:WIDTH:TYPE BETWEEN
:TRIGGER:WIDTH:TYPE? ->
:TRIGGER:WIDTH:TYPE BETWEEN

:TRIGger:WIDTh:WINDow

Function Turns the window ON/OFF when using the pulse width trigger or queries the current setting.

Syntax :TRIGger:WIDTh:WINDow {<Boolean>}
:TRIGger:WIDTh:WINDow?

Example :TRIGGER:WIDTH:WINDOW ON
:TRIGGER:WIDTH:WINDOW? ->
:TRIGGER:WIDTH:WINDOW 1

5.31 WAVEform Group

The commands in the WAVEform group are used to make settings and queries about acquired waveform data. There is no front panel key for this function.

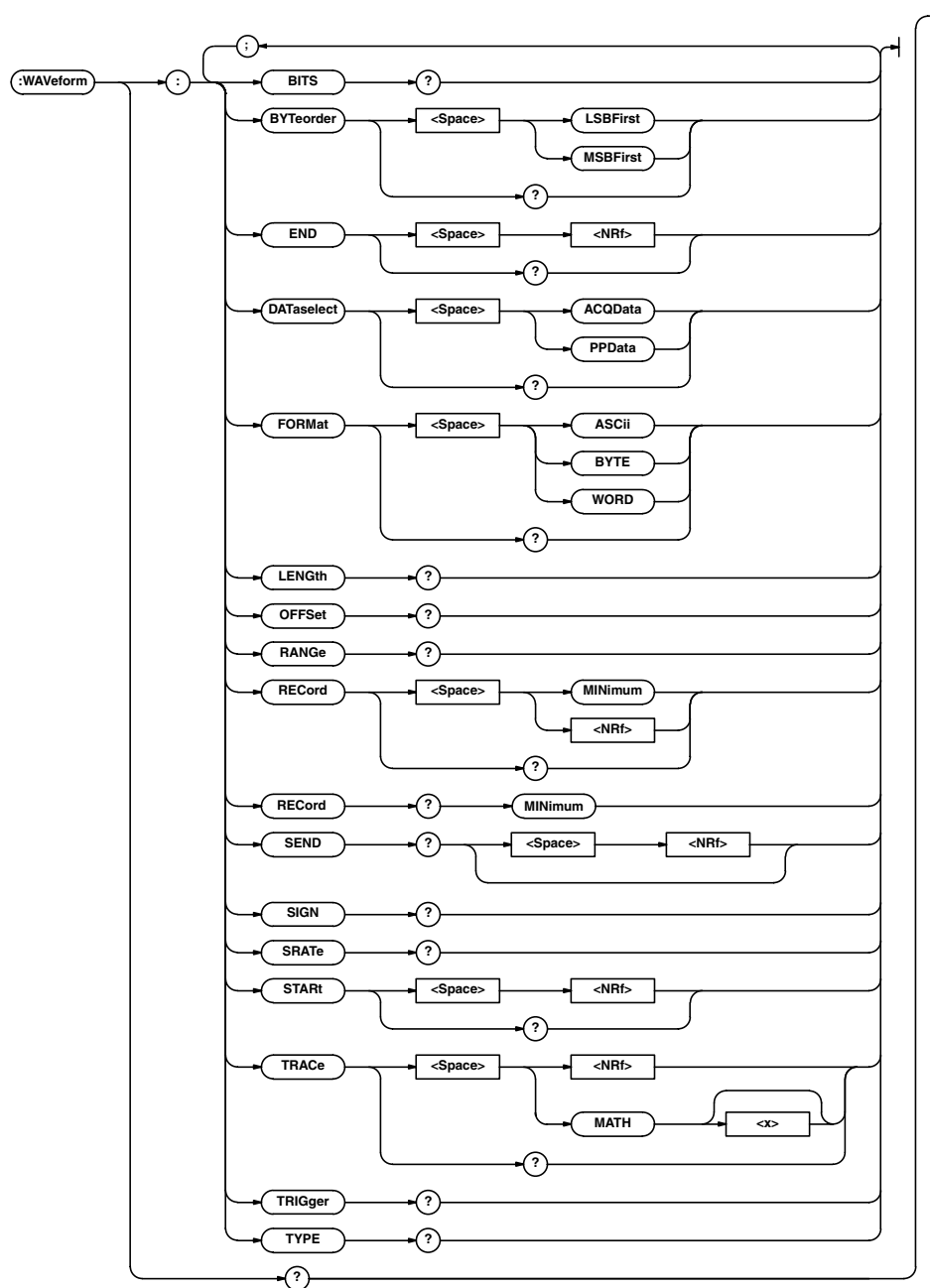

:WAVEform?

Function Queries all information relating to the waveform data.

Syntax :WAVEform?

Example :WAVEFORM? -> :WAVEFORM:TRACE 1;
RECORD 0;START 0;END 0;
DATASELECT ACQDATA;FORMAT WORD;
BYTEORDER LSBFIRST

:WAVEform:BITS?

Function Queries the bit length of the waveform data designated by "WAVEform:TRACE."

Syntax :WAVEform:BITS?

Example :WAVEFORM:BITS? ->
:WAVEFORM:BITS 16

5.31 WAVEform Group

:WAVEform:BYTeorder

Function Sets/queries the order used to transmit words consisting of multiple bytes.

Syntax :WAVEform:BYTeorder
{LSBFirst|MSBFirst}
:WAVEform:BYTeorder?

Example :WAVEFORM:BYTEORDER LSBFIRST
:WAVEFORM:BYTEORDER? ->
:WAVEFORM:BYTEORDER LSBFIRST

:WAVEform:DATaselect

Function Sets whether to use the ACQ data or P-P data when querying the waveform that is specified with the "WAVEform:TRACe" command or queries the current setting.

Syntax :WAVEform:DATaselect
{ACQData|PPData}
:WAVEform:DATaselect?

Example :WAVEFORM:DATASELECT ACQDATA
:WAVEFORM:DATASELECT? ->
:WAVEFORM:DATASELECT ACQDATA

:WAVEform:END

Function Sets/queries the point at which the last item of data of the waveform designated by "WAVEform:TRACe" is to be located.

Syntax :WAVEform:END {<NRf>}
:WAVEform:END?
<NRf>= 0 to 1001999 (DL1720E)
0 to 2003999 (DL1740E)
0 to 8015999 (DL1740EL)

Example :WAVEFORM:END 1001
:WAVEFORM:END? -> :WAVEFORM:END
1001

Description You can query total data length (points) with the "WAVEform:LENGth" command.

:WAVEform:FORMat

Function Sets/queries the format in which the data is to be transmitted.

Syntax :WAVEform:FORMat {ASCIi|BYTE|WORD}
:WAVEform:FORMat?

Example :WAVEFORM:FORMAT ASCII
:WAVEFORM:FORMAT? ->
:WAVEFORM:FORMAT ASCII

Description For information on the different formats selected with this command, refer to the Description section of "WAVEform:SEND?."

:WAVEform:LENGth?

Function Queries the number of records (total number of data points) in the waveform designated by "WAVEform:TRACe."

Syntax :WAVEform:LENGth?

Example :WAVEFORM:LENGTH? ->
:WAVEFORM:LENGTH 1002

:WAVEform:OFFSet?

Function Queries the offset value that is used when converting the waveform specified by the "WAVEform:TRACe" command to physical values.

Syntax :WAVEform:OFFSet?

Example :WAVEFORM:OFFSET? -> 0.000E+00

Description This offset value is used when converting the <block data> that are output by the "WAVEform:SEND?" command to physical values.

:WAVEform:RANGe?

Function Queries the range that is used when converting the waveform specified by the "WAVEform:TRACe" command to physical values.

Syntax :WAVEform:RANGe?

Example :WAVEFORM:RANGE? -> 5.000E+00

Description This value is used when converting the <block data> that is output with the "WAVEform:SEND?" command to physical values.

:WAVEform:RECOrd

Function Sets/queries the target record No. for the WAVEform group.

Syntax :WAVEform:RECOrd {MINimum|<NRf>}
:WAVEform:RECOrd?
<NRf>= 0 to -1023 (DL1720E)
0 to -2047 (DL1740E/DL1740EL)

Example :WAVEFORM:RECORD 0
:WAVEFORM:RECORD? ->
:WAVEFORM:RECORD 0

Description If "MINimum" is specified, the record number is set to the minimum value. The record numbers that can be selected vary depending on the extension memory and the acquisition settings. For details, see the User's Manual.

:WAVEform:RECOrd? MINimum

Function Queries the smallest record number of the history of the channel.

Syntax :WAVEform:RECOrd? MINimum

Example :WAVEFORM:RECORD? MINimum ->
:WAVEFORM:RECORD -1023

:WAVEform:SEND?

Function	Queries the waveform data specified with the "WAVEform:TRACe" command.
Syntax	:WAVEform:SEND? [{<NRf>}] <NRf>= 1 to 1024 (DL1720E) 1 to 2048 (DL1740E/DL1740EL) (depends on the record length setting)
Example	:WAVEFORM:SEND? -> #8 (number of bytes, 8 digits)(data string) or, <NRf>, <NRf>,
Description	The output format of "WAVEform:SEND?" varies depending on the "WAVEform:FORMat" setting. (1)When set to "ASCIi" <ul style="list-style-type: none"> When the "WAVEform:TRACe" is 1 to 8 and the linear scaling is OFF, the values are returned in the following format: <voltage>, <voltage>, ...<voltage> When the "WAVEform:TRACe" is a logic input, the values are returned in the following format: <NR1>, <NR1>, ..., <NR1> <NR1> is an 8-bit pattern (bit 7 to 0) that has been made into a decimal. For all other cases, the values are returned in the form: <NRf>, <NRf>, ..., <NRf>. (2)When set to "BYTE" or "WORD" The values are returned in the <block data> format. <ul style="list-style-type: none"> When the "WAVEform:TRACe" is not set to a logic input, the following equation can be used to convert the values. Voltage (computed value) = (Range × data ÷ division) + offset * "BYTE": Division = 12 * "WORD": Division = 3072 Query is not possible if "WAVEform:TRACe" set to MATH1 or MATH2 and the computation is turned OFF. <NRf> can be omitted. If <NRf> is added, waveform data are queried <NRf> times from the record number specified by the "WAVEform:RECOrd" command - <NRf> in order.

:WAVEform:SIGN?

Function	Queries the presence of the sign, when querying the waveform specified with "WAVEform:TRACe" in binary data form.
Syntax	:WAVEform:SIGN?
Example	:WAVEFORM:SIGN? -> :WAVEFORM:SIGN 1

:WAVEform:SRATE? (Sample RATE)

Function	Queries the sampling rate for the record designated by "WAVEform:RECOrd".
Syntax	:WAVEform:SRATE?
Example	:WAVEFORM:SRATE? -> :WAVEFORM:SRATE 1.0E+09

:WAVEform:START

Function	Sets/queries the point at which the first item of data of the waveform designated by "WAVEform:TRACe" is to be located.
Syntax	:WAVEform:START {<NRf>} :WAVEform:START? <NRf>= 0 to 1001999 (DL1720E) 0 to 2003999 (DL1740E) 0 to 8015999 (DL1740EL)
Example	:WAVEFORM:START 0 :WAVEFORM:START? -> :WAVEFORM:START 0

:WAVEform:TRACe

Function	Sets/queries the target waveform for the WAVEform group.
Syntax	:WAVEform:TRACe {<NRf> MATH<x>} :WAVEform:TRACe? <x>=1 or 2 (1 on the DL1720E) <NRf>=1 to 4 (1 to 2 on the DL1720E)
Example	:WAVEFORM:TRACe 1 :WAVEFORM:TRACe? -> :WAVEFORM:TRACe 1

:WAVEform:TRIGGER?

Function	Queries the trigger point for the record designated by "WAVEform:RECOrd".
Syntax	:WAVEform:TRIGGER?
Example	:WAVEFORM:TRIGGER? -> :WAVEFORM:TRIGGER 2000
Description	Returns the number of points between the record start and the trigger position.

:WAVEform:TYPE?

Function	Queries the acquisition mode for the waveform specified by the "WAVEform:TRACe" command.
Syntax	:WAVEform:TYPE?
Example	:WAVEFORM:TYPE? -> :WAVEFORM:TYPE NORMAL

5.32 XY Group

The commands in the XY group are used to make settings and queries about the X-Y display. You can make the same settings that can make using SHIFT+DISPLAY on the front panel.

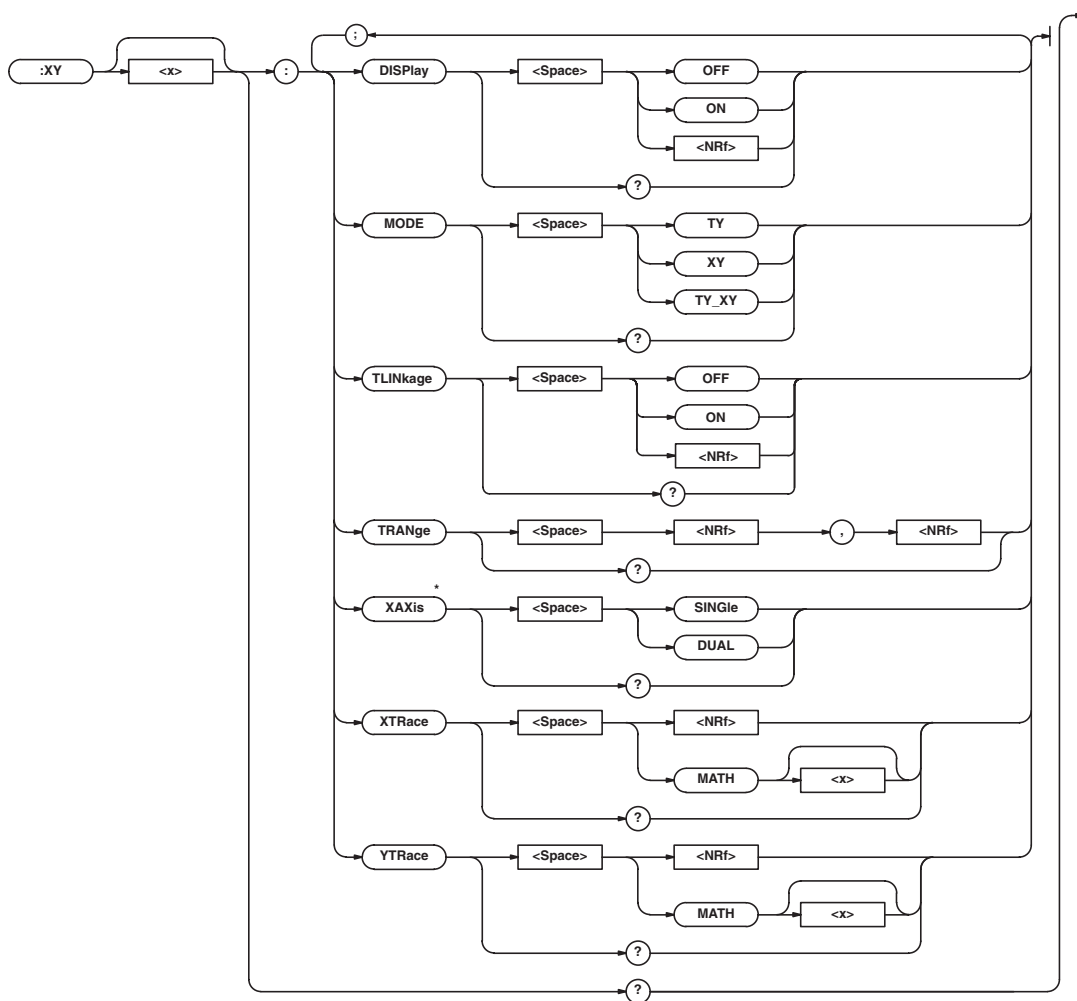

* For use on the DL1740E/DL1740EL.

:XY<x>?

Function Queries all settings related to the X-Y display.
 Syntax :XY<x>?
 <x>=1 or 2 (1 on the DL1720E)
 Example :XY1? -> :XY1:MODE XY;XAXIS SINGLE;
 DISPLAY 1;TRANGe -5.00,5.00;
 XTRACE 1;TLINKAGE 0;YTRACE 2

:XY<x>:DISPlay

Function Sets whether or not to display the X-Y waveform or queries the current setting.
 Syntax :XY<x>:DISPlay {<Boolean>}
 :XY<x>:DISPlay?
 <x>=1 or 2 (1 on the DL1720E)
 Example :XY1:DISPlay ON
 :XY1:DISPlay? -> :XY1:DISPlay 1

:XY<x>:MODE

Function Sets the display mode or queries the current setting.
 Syntax :XY<x>:MODE {T-Y | TY_XY | XY}
 :XY<x>:MODE?
 <x>=1 or 2 (1 on the DL1720E)
 Example :XY1:MODE XY
 :XY1:MODE? -> :XY1:MODE XY
 Description The setting or query is the same whether <x> is set to 1 or 2.

:XY<x>:TLINKage

Function Turns ON/OFF the linked movement of the determination range cursor.
 Syntax :XY<x>:TLINKage {<Boolean>}
 :XY<x>:TLINKage?
 <x>=1 or 2 (1 on the DL1720E)
 Example :XY1:TLINKAGE ON
 :XY1:TLINKAGE -> :XY1:TLINKAGE 1

:XY<x>:TRAnge (Time Range)

Function Sets the range of the T-Y waveform to be used in the X-Y display or queries the current setting.

Syntax **:XY<x>:TRAnge** {<NRf>,<NRf>}
:XY<x>:TRAnge?
 <x>=1 or 2 (1 on the DL1720E)
 <NRf>=-5 to 5 div (10 div/displayed record length steps)

Example **:XY1:TRAnge -4,4**
:XY1:TRAnge? ->
:XY1:TRAnge -4.00,4.00

:XY<x>:XAXis

Function Sets the X-axis mode (Single/Dual) or queries the current setting. (DL1740E/DL1740EL only)

Syntax **:XY<x>:XAXis** {SINGLe|DUAL}
:XY<x>:XAXis?
 <x>=1 or 2

Example **:XY1:XAXis SINGLE**
:XY1:XAXis? -> :XY1:XAXis SINGLE

Description The setting or query is the same whether <x> is set to 1 or 2.

:XY<x>:XTRace

Function Sets the channel that is to be assigned to the X-axis in the X-Y display or queries the current setting.

Syntax **:XY<x>:XTRace** {<NRf>|MATH<x>}
:XY<x>:XTRace?
 <x> of XY<x>=1 or 2 (1 on the DL1720E)
 <x> of MATH<x>=1 or 2 (1 on the DL1720E)
 <NRf>=1 to 4 (1 to 2 on the DL1720E)

Example **:XY1:XTRACE 1**
:XY1:XTRACE? -> :XY1:XTRACE 1

Description

- When “:XY<x>:XAXis” is set to SINGLE
 <NRf>=1 to 4
 <x> of MATH<x>=1 or 2
- When “:XY<x>:XAXis” is set to DUAL
 If XY<x>=XY1:
 <NRf>=1 or 2
 <x> of MATH<x>=1
 If XY<x>=XY2:
 <NRf>=3 or 4
 <x> of MATH<x>=2

:XY<x>:YTRace

Function Sets the channel that is to be assigned to the Y-axis in the X-Y display or queries the current setting.

Syntax **:XY<x>:YTRace** {<NRf>|MATH<x>}
:XY<x>:YTRace?
 <x> of XY<x>=1 or 2 (1 on the DL1720E)
 When the <x> in XY<x> is 1:
 <NRf>=1 or 2
 <x> of MATH<x>=1
 When the <x> in XY<x> is 2 (DL1740E/DL1740EL only):
 <NRf>=3, 4
 <x> of MATH<x>=2

Example **:XY1:YTRACE 1**
:XY1:YTRACE? -> :XY1:YTRACE 1

5.33 ZOOM Group

5.33 ZOOM Group

The commands in the ZOOM group are used to make settings and queries about the zoom function. These settings can also be made using the ZOOM key on the front panel.

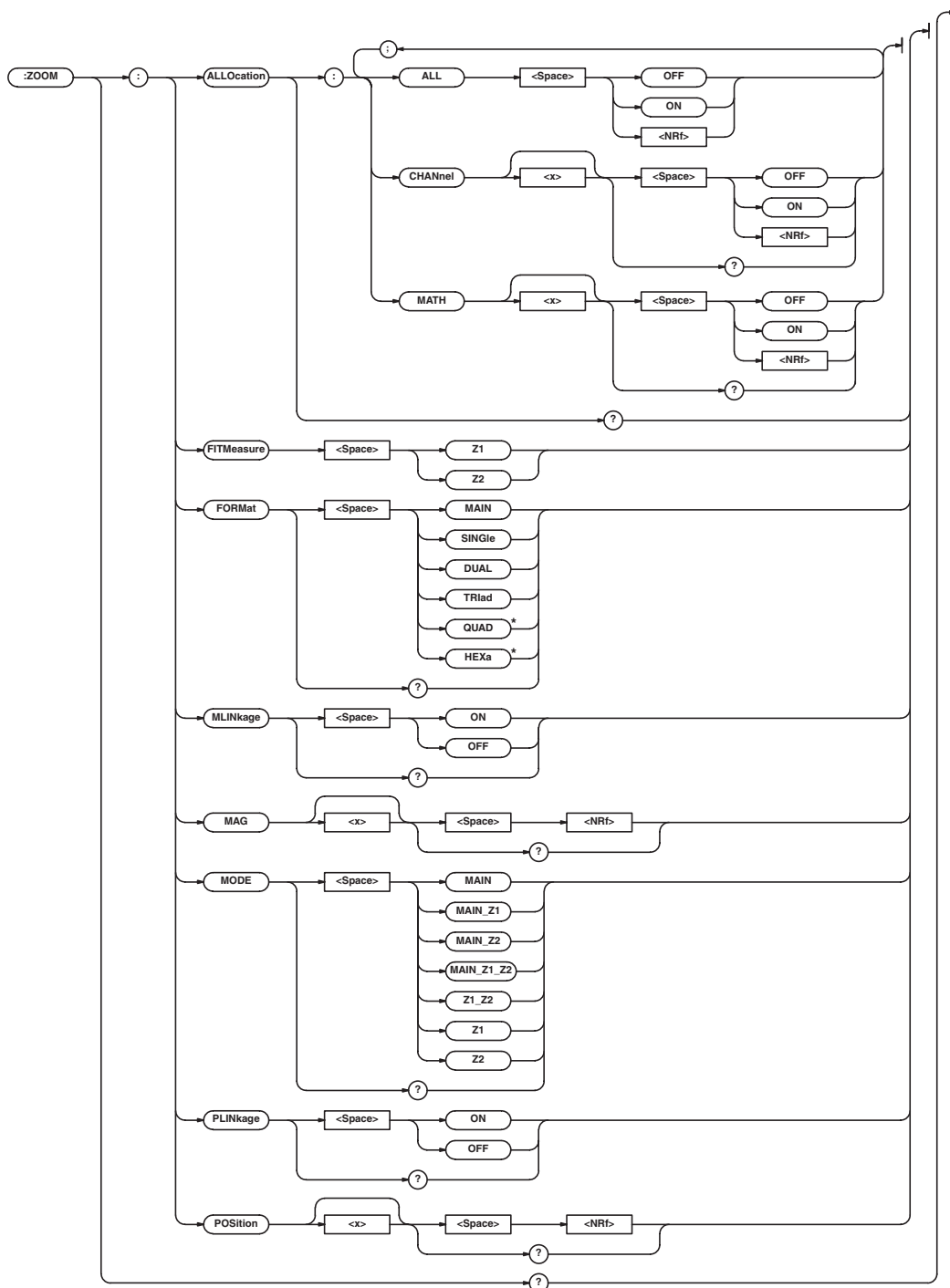

* Can be used on the DL1740E/DL1740EL.

: ZOOM?

Function Queries all waveform zoom settings.
 Syntax :ZOOM?
 Example :ZOOM? -> :ZOOM:MODE MAIN;
 FORMAT MAIN;ALLOCATION:CHANNEL1 1;
 CHANNEL2 1;CHANNEL3 1;CHANNEL4 1;
 CHANNEL5 1;CHANNEL6 1;CHANNEL7 1;
 CHANNEL8 1;MATH1 0;MATH2 0;PODA 0;
 PODB 0;;ZOOM:MLINKAGE 1;MAG1 2.0;
 MAG2 2.0;PLINKAGE 0;
 POSITION1 0.0000000;
 POSITION2 0.0000000

: ZOOM:ALLOcation?

Function Queries settings for the zoomed waveform.
 Syntax :ZOOM:ALLOcation?
 Example :ZOOM:ALLOCATION? ->
 :ZOOM:ALLOCATION:CHANNEL1 1;
 CHANNEL2 0;CHANNEL3 0;CHANNEL4 0;
 MATH1 0;MATH2 0

: ZOOM:ALLOcation:ALL

Function Selects all waveforms to be zoomed.
 Syntax :ZOOM:ALLOcation:ALL {<Boolean>}
 Example :ZOOM:ALLOCATION:ALL ON

**: ZOOM:ALLOcation:{CHANnel<x>|
MATH<x>}**

Function Selects/queries the zoomed waveform.
 Syntax :ZOOM:ALLOcation:{CHANnel<x>|
MATH<x>} {<Boolean>}
 :ZOOM:ALLOcation:{CHANnel<x>|
MATH<x>}?
 <x>(CHANnel)=1 to 4 (1 to 2 on the DL1720E)
 <x>(MATH)=1 or 2 (1 on the DL1720E)
 Example :ZOOM:ALLOCATION:CHANNEL1 ON
 :ZOOM:ALLOCATION:CHANNEL1? ->
 :ZOOM:ALLOCATION:CHANNEL1 1

: ZOOM:FITMeasure

Function Changes the range of the automated measurement of waveform parameters to the ends of the zoom box.
 Syntax :ZOOM:FITMeasure {Z1|Z2}
 :ZOOM:FITMeasure?
 Example :ZOOM:FITMEASURE Z1
 :ZOOM:FITMEASURE? ->
 :ZOOM:FITMEASURE Z1

: ZOOM:FORMat

Function Sets/queries the zoom display format.
 Syntax :ZOOM:FORMat
 {MAIN|SINGLE|DUAL|TRIad|QUAD|HEXA}
 :ZOOM:FORMat?
 Example :ZOOM:FORMAT SINGLE
 :ZOOM:FORMAT? ->
 :ZOOM:FORMAT SINGLE
 Description QUAD and HEXA not available on the DL1720E.

: ZOOM:MLINKage (Mag Linkage)

Function Enables/disables/queries zoom ratio linkage.
 Syntax :ZOOM:MLINKage {<Boolean>}
 :ZOOM:MLINKage?
 Example :ZOOM:MLINKAGE ON
 :ZOOM:MLINKAGE? -> :ZOOM:MLINKAGE 1

: ZOOM:MAG<x>

Function Sets the zoom rate of the zoomed waveform or queries the current setting.
 Syntax :ZOOM:MAG<x> {<NRf>}
 :ZOOM:MAG<x>?
 <x>=1, 2
 <NRf>=magnification up to 40 points. See the User's Manual.
 Example :ZOOM:MAG1 2.5
 :ZOOM:MAG1? -> :ZOOM:MAG1 2.5

: ZOOM:MODE

Function Sets the zoom waveform display mode or queries the current setting.
 Syntax :ZOOM:MODE {MAIN|MAIN_Z1|
MAIN_Z2|MAIN_Z1_Z2|Z1_Z2|Z1|Z2}
 :ZOOM:MODE?
 Example :ZOOM:MODE MAIN_Z1_Z2
 :ZOOM:MODE? ->
 :ZOOM:MODE MAIN_Z1_Z2

: ZOOM:PLINKage (Position Linkage)

Function Turns the link ON/OFF when moving the zoom box or queries the current setting.
 Syntax :ZOOM:PLINKage {<Boolean>}
 :ZOOM:PLINKage?
 Example :ZOOM:PLINKAGE ON
 :ZOOM:PLINKAGE? -> :ZOOM:PLINKAGE 1

: ZOOM:POsition<x>

Function Sets/queries the zoom box position.
 Syntax :ZOOM:POsition<x> {<NRf>}
 :ZOOM:POsition<x>?
 <x>=1, 2
 <NRf>=-5 to 5 div (in steps of 10 div/display-record-length)
 Example :ZOOM:POSITION1 2
 :ZOOM:POSITION1? ->
 :ZOOM:POSITION1 2.00E+00

5.34 Common Command Group

The commands in the common command group are independent of the instrument's functions, and are specified in IEEE 488.2-1987. There is no front panel key that corresponds to this group.

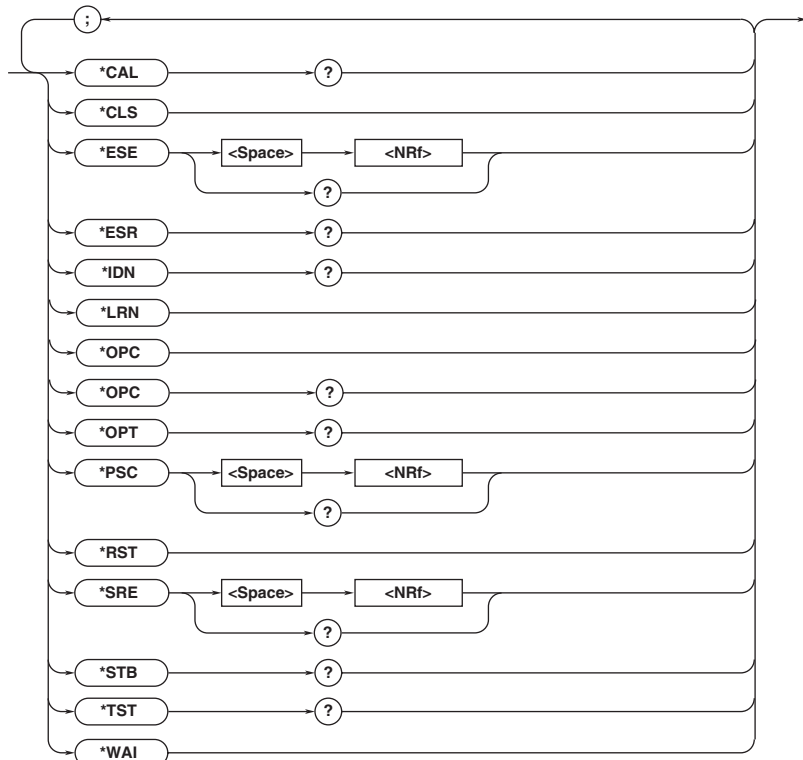

***CAL? (CALibrate)**

Function Performs calibration and queries about the result.

Syntax *CAL?

Example *CAL? -> 0

Description "0" will be returned if calibration is completed properly, and "1" will be returned if an abnormality has been detected during calibration.

***CLS (CLear Status)**

Function Clears the standard event register, extended event register and error queue.

Syntax *CLS

Example *CLS

Description

- The output queue will also be cleared if a *CLS command is appended after the program message terminator.
- For details of the registers and queue, refer to Chapter 6.

***ESE (standard Event Status Enable register)**

Function Sets the value for the standard event enable register/queries about the current setting.

Syntax *ESE {<NRf>}
*ESE?

Example *ESE 251
*ESE? -> 251

Description

- <NRf> is the sum of the bits expressed as a decimal number.
- For example, if "*ESE 251" is set, the standard event enable register will be set to "11111011." This means that bit 2 of the standard event register is disabled so that bit 5 (ESB) of the status byte register will not be set to "1," even if an query error occurs.
- Default is "*ESE 0," i.e. all bits are disabled.
- The standard event enable register will not be cleared, even if an query is made using "*ESE?."
- For details of the standard event enable register, refer to page 6-3.

***ESR? (standard Event Status Register)**

Function Queries about the value of the standard event register and clears it at the same time.

Syntax *ESR?

Example *ESR? -> 32

Description

- The sum of the bits is returned as a decimal value.
- It is possible to ascertain the type of event which has occurred, while SRQ is occurring.
- For example, if "32" is returned, this means that the standard event register is "00100000," i.e. the SRQ has occurred due to a command syntax error.
- If an query is made using "*ESR?," the standard event register will be cleared.
- For details of the standard event register, refer to page 6-3.

***IDN? (IDentify)**

Function Queries the instrument model.

Syntax *IDN?

Example *IDN? -> YOKOGAWA,701730,0,F1.10

Description The information is returned in the following form: <Manufacturer>,<Model>,<Serial No.>,<Firmware version>. In the actual case, <Serial No.> is not returned (always 0). 701715 is returned if the model is the DL1720E, 701730 if it is the DL1740E, and 701740 if it is the DL1740EL.respectively.

***LRN? (Learn)**

Function Queries about all the current settings for the following command groups.
ACQuire, CHANnel-x>, TIMEbase, TRIGger

Syntax *LRN?

Example *LRN? -> :ACQUIRE:RLENGTH 10000;
MODE NORMAL;AVERAGE:COUNT INFINITY;
EWEIGHT 16;:ACQUIRE:COUNT INFINITY;
INTERLEAVE 0;REPETITIVE 0;
CLOCK INTERNAL;:CHANNEL1:DISPLAY 1;
VDIV 50.0000E+00;POSITION 0.00;
COUPLING DC;PROBE 10;
OFFSET 0.0E+00;BWIDTH FULL;
VARIABLE 50.000E+00;LSCALE:MODE 0;
AVALUE 1.00000E+00;
BVALUE 0.00000E+00;UNIT " ";;
CHANNEL1:LABEL "CH1";:CHANNEL2:
DISPLAY 1;VDIV 50.000E+00;
POSITION 0.00;COUPLING DC;PROBE 10;
OFFSET 0.0E+00;BWIDTH FULL;
VARIABLE 50.000E+00;LSCALE:MODE 0;
AVALUE 1.00000E+00;
BVALUE 0.00000E+00;UNIT " ";;
CHANNEL2:LABEL "CH2";:CHANNEL3:
DISPLAY 1;VDIV 50.000E+00;
POSITION 0.00;COUPLING DC;PROBE 10;
OFFSET 0.0E+00;BWIDTH FULL;
VARIABLE 50.000E+00;LSCALE:MODE 0;
AVALUE 1.00000E+00;
BVALUE 0.00000E+00;UNIT " ";;
CHANNEL3:LABEL "CH3";:CHANNEL4:
DISPLAY 1;VDIV 50.000E+00;
POSITION 0.00;COUPLING DC;PROBE 10;
OFFSET 0.0E+00;BWIDTH FULL;
VARIABLE 50.000E+00;LSCALE:MODE 0;
AVALUE 1.00000E+00;

```
BVALUE 0.00000E+00;UNIT " ";;
CHANNEL4:LABEL "CH4";:TIMEBASE:
SOURCE INTERNAL;TDIV 1.0E-03;;
TRIGGER:ACTION:BUZZER 0;SAVE 0;
HCOPY 0;ACQCOUNT INFINITE;;
TRIGGER:SIMPLE:SOURCE 1;
LEVEL 0.0E+00;SLOPE RISE;
COUPLING DC;HFREJECTION OFF;
HYSTERESIS LOW;PROBE 1;:TRIGGER:
SOURCE:CHANNEL1:LEVEL 0.0E+00;
COUPLING DC;HFREJECTION OFF;
HYSTERESIS LOW;WIDTH 50.000E+00;;
TRIGGER:SOURCE:CHANNEL2:
LEVEL 0.0E+00;COUPLING DC;
HFREJECTION OFF;HYSTERESIS LOW;
WIDTH 50.000E+00;:TRIGGER:SOURCE:
CHANNEL3:LEVEL 0.0E+00;COUPLING DC;
HFREJECTION OFF;HYSTERESIS LOW;
WIDTH 50.000E+00;:TRIGGER:SOURCE:
CHANNEL4:LEVEL 0.0E+00;COUPLING DC;
HFREJECTION OFF;HYSTERESIS LOW;
WIDTH 50.000E+00;:TRIGGER:ABN:
COUNT 1;:TRIGGER:HOLDOFF:
TIME 80.000E-09;:TRIGGER:ADB:
DELAY 1.000E-09;:TRIGGER:
DELAY 0.0E+00;PATTERN:CLOCK:
SOURCE 1;SLOPE RISE;:TRIGGER:
PATTERN:CHANNEL1 HIGH;
CHANNEL2 DONTCARE;
CHANNEL3 DONTCARE;
CHANNEL4 DONTCARE;
CONDITION TRUE;:TRIGGER:
POSITION 50.000;MODE AUTO;WIDTH:
TYPE IN;CHANNEL1 HIGH;
CHANNEL2 HIGH;CHANNEL3 HIGH;
CHANNEL4 HIGH;CONDITION TRUE;
TIME1 1.000E-09;TIME2 1.000E-09;
WINDOW 0;:TRIGGER:OR:WINDOW 0;
CHANNEL1 RISE;CHANNEL2 OFF;
CHANNEL3 OFF;CHANNEL4 OFF;:TRIGGER:
SCOUNT 2;TV:TYPE NTSC;
POLARITY NEGATIVE;LEVEL 5000000.0;
FIELD 1;LINE 5;FRAME 1;:TRIGGER:
TYPE SIMPLE;ATRIGGER:CHANNEL1 HIGH;
CHANNEL2 DONTCARE;
CHANNEL3 DONTCARE;
CHANNEL4 DONTCARE;CONDITION ENTER;:
TRIGGER:BTRIGGER:CHANNEL1 DONTCARE;
CHANNEL2 HIGH;CHANNEL3 DONTCARE;
CHANNEL4 DONTCARE;CONDITION
```

***OPC (Operation Complete)**

Function Sets bit 0 (OPC bit) of the standard event register to "1" when execution of an overlap command is completed.

Syntax *OPC

Example *OPC

Description

- For a description of the synchronization method using "*OPC," refer to page 4-8.
- Designation of an overlap command is performed using ":COMMunicate:OPSE."
- Operation is not guaranteed if "*OPC" is not appended to the end of the message.

5.34 Common Command Group

***OPC? (Operation Complete)**

Function After “*OPC?” is sent, “1” (ASCII) will be returned if execution of the designated overlap command has been completed.

Syntax *OPC?

Example *OPC? -> 1

Description

- For a description of the synchronization method using “*OPC?,” refer to page 4-8.
- Designation of an overlap command is performed using “COMMunicate:OPSE.”
- Operation is not guaranteed if “*OPC” is not appended to the end of the message.

***OPT? (OPTION)**

Function Queries the installed options.

Syntax *OPT?

Example *OPT? -> CH4MW,FLOPPY,PRINTER,
LOGIC,SCSI,ETHER,USERDEFINE

Description

- Returns the presence of <memory model>, <floppy disk or Zip drive>, <printer>, <logic>, <SCSI>, <Ethernet>, and <user-defined computation>.
- The “*OPT?” query must be the last query of the program message. An error occurs if there is a query after this query.

***PSC (Power-on Status Clear)**

Function Selects/queries whether following registers are cleared when power is turned ON. However, they cannot be cleared if the parameter is “0” when rounded.

- Standard event enable register
- Extended event enable register
- Transit filter

Syntax *PSC {<NRf>}

*PSC?

<NRf>=0 (does not clear the registers), a value other than 0 (clears the registers)

Example *PSC 1

*PSC? -> 1

Description For details of each register, refer to Chapter 6.

***RST (ReSeT)**

Function Resets the current settings of the following groups at once.
ACCumulate, ACQuire, CHANnel<x>,
TIMebase, TRIGger

Syntax *RST

Example *RST

Description Previously sent *OPC and *OPC? commands are also cleared.

***SRE (Service Request Enable register)**

Function Sets the value of the service request enable register/inquires about the current setting.

Syntax *SRE <NRf>

*SRE?

<NRf>=0 to 255

Example *SRE 239

*SRE? -> 239

Description

- <NRf> is the sum of the bits expressed as a decimal number. For example, if “*ESE 239” is set, the service request enable register will be set to “11101111.” This means that bit 4 of the service request enable register is disabled, so that bit 5 (ESB) of the status byte register will not be set to “1,” even if the output queue is not empty. However, bit 6 (MSS) of the status byte register is the MSS bit, so it will be ignored.
- Default is “*SRE 0,” i.e. all bits are disabled.
- The service request enable register will not be cleared, even if a query is made using “*SRE?”.
- For details of the service request enable register, refer to page 6-1.

***STB? (STatus Byte)**

Function Queries about the value of the status byte register.

Syntax *STB?

Example *STB? -> 4

Description

- The sum of the bits expressed as a decimal value is returned.
- Bit 6 is MSS not RQS, since the register is read without serial polling. For example, if “4” is returned, the status byte register is set to “00000100,” i.e. the error queue is not empty (an error has occurred).
- The status byte register will be cleared, even if a query is made using “*STB?”.
- For details of the status byte register, refer to page 6-2.

***TST?**

Function Executes self test and queries the result. The self test involves internal memory tests.

Syntax *TST?

Example *TST? -> 0

Description “0” is returned if the self test is successful, “1” if it is not.

***WAI (WAIt)**

Function Waits for the command following “*WAI” until execution of the designated overlap command is completed.

Syntax *WAI

Example *WAI

Description

- For a description of the synchronization method using “*WAI,” refer to page 4-8.
- Designation of overlap commands can be performed using “:COMMunicate:OPSE.”

Chapter 6 Status Report

6.1 Overview of the Status Report

The figure below shows the status report which is read by a serial poll. This is an extended version of the one specified in IEEE 488.2-1992.

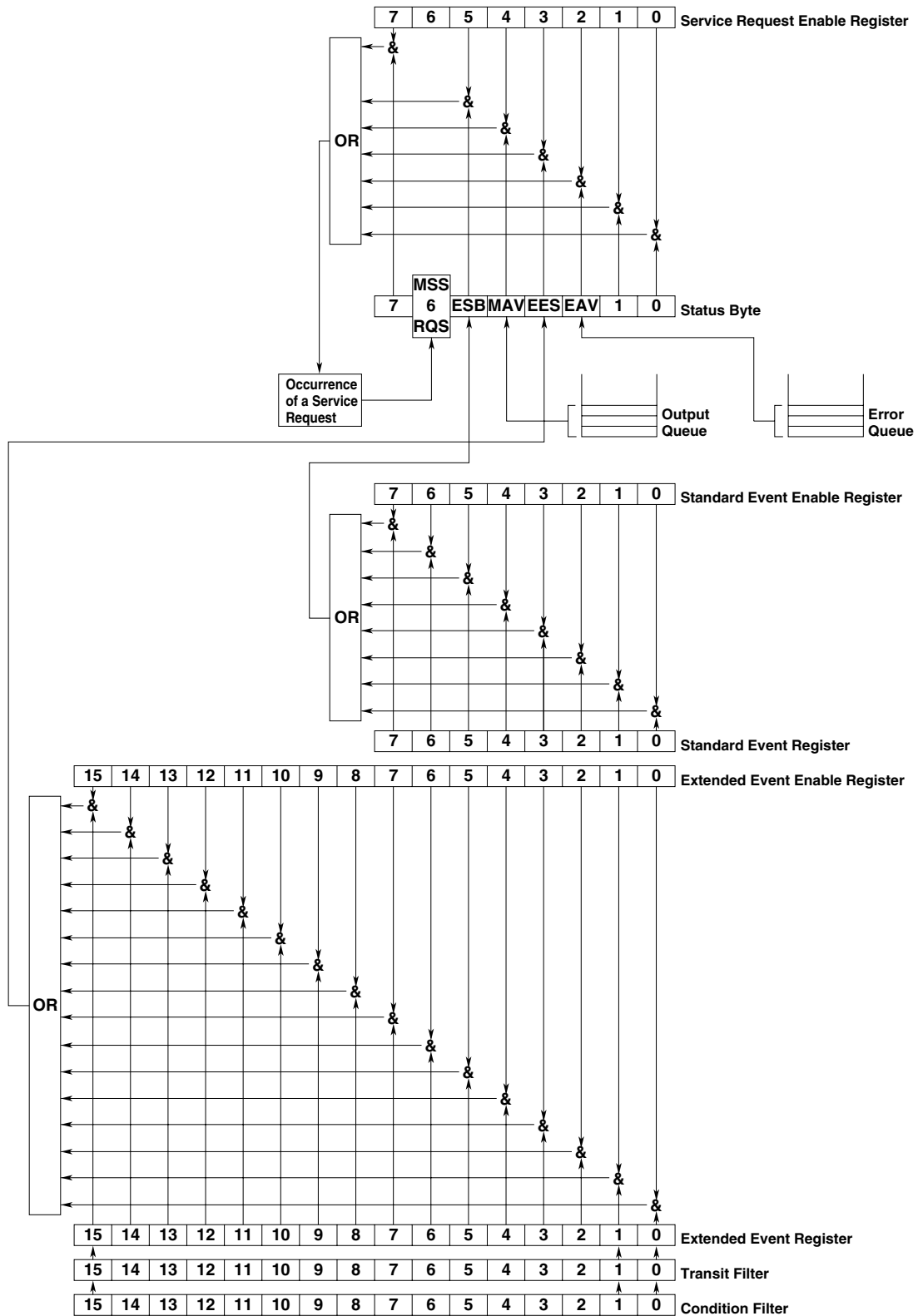

6.1 Overview of the Status Report/6.2 Status Byte

Overview of Registers and Queues

Name	Function	Writing	Reading
Status byte		—	Serial poll (RQS), *STB?(MSS)
Service request enable register	Masks status byte.	*SRE	*SRE?
Standard event register	Change in device status	—	*ESR?
Standard event enable register	Masks standard event register	*ESE	*ESE?
Extended event register	Change in device status	—	STATUS: EESR?
Extended event enable register	Masks standard event register	STATUS: EESE	STATUS: EESE?
Condition register	Current instrument status	—	STATUS: CONDITION?
Transit filter	Extended event occurrence conditions	STATUS: FILTER<x>	STATUS: FILTER<x>?
Output queue	Stores response message to a query.	All executable queues	
Error queue	Stores error Nos. and messages.	—	STATUS: ERROR?

Registers and Queues which Affect the Status Byte
Registers which affect each bit of the status byte are shown below.

Standard event register: Sets bit 5 (ESB) of status byte to "1" or "0."
Output queue: Sets bit 4 (MAV) of status byte to "1" or "0."
Extended event register: Sets bit 3 (EES) of status byte to "1" or "0."
Error queue: Sets bit 2 (EAV) of status byte to "1" or "0."

Enable Registers

Registers which mask a bit so that the bit does not affect the status byte, even if the bit is set to "1," are shown below.

Status byte: Masks bits using the service request enable register.
Standard event register: Masks bits using the standard event enable register.
Extended event register: Masks bits using the extended event enable register.

Writing/Reading from Registers

The *ESE command is used to set bits in the standard event enable register to "1" or "0," and the *ESE query is used to check whether bits in that register are set to "1" or "0." For details of these commands, refer to Chapter 5.

6.2 Status Byte

Overview of Status Byte



Bits 0, 1 and 7

Not used (always "0")

Bit 2 EAV (Error Available)

Set to "1" when the error queue is not empty, i.e. when an error occurs. For details, refer to page 6-5.

Bit 3 EES (Extended Event Summary Bit)

Sets to "1" when the logical "AND" of an Extended Event Register bit and the corresponding Enable Register bit is equal to "1."—that is, when an event takes place in the instrument. Refer to page 6-4.

Bit 4 MAV (Message Available)

Set to "1" when the output queue is not empty, i.e. when there is data which is to be output when an query is made. Refer to page 6-5.

Bit 5 ESB (Event Summary Bit)

Set to "1" when the logical AND of the standard event register and the corresponding enable register is "1," i.e. when an event takes place in the instrument. Refer to page 6-3.

Bit 6 RQS (Request Status)/MSS (Master Summary Status)

Sets to "1" when the logical "AND" of any one of the Status Byte bits (other than bit 6) and the corresponding Service Request Enable Register bit becomes "1"—that is, when the instrument is requesting service from the controller.

RQS is set to "1" when MSS changes from "0" to "1," and is cleared when a serial poll is performed or when MSS changes to "0."

Bit Masking

To mask a bit in the status byte so that it does not cause an SRQ, set the corresponding bit of the service request enable register to "0."

For example, to mask bit 2 (EAV) so that no service will be requested, even if an error occurs, set bit 2 of the service request enable register to "0." This can be done using the *SRE command. To query whether each bit of the service request enable register is "1" or "0," use *SRE?. For details of the *SRE command, refer to Chapter 5.

Operation of the Status Byte

A service request is issued when bit 6 of the status byte becomes "1." Bit 6 becomes "1" when any of the other bits becomes "1" (or when the corresponding bit in the service request enable register becomes "1").

For example, if an event takes place and the logical OR of each bit of the standard event register and the corresponding bit in the enable register is "1," bit 5 (ESB) will be set to "1." In this case, if bit 5 of the service request enable register is "1," bit 6 (MSS) will be set to "1," thus requesting service from the controller.

It is also possible to check what type of event has occurred by reading the contents of the status byte.

Reading from the Status Byte

The following two methods are provided for reading the status byte.

- **Inquiry Using the *STB? Query**
Making an inquiry using the *STB? query sets bit 6 to MSS. This causes the MSS to be read. After completion of the read-out, none of the bits in the status byte will be cleared.
- **Serial Poll**
Execution of a serial poll changes bit 6 to RQS. This causes RQS to be read. After completion of the read-out, only RQS is cleared. Using a serial poll, it is not possible to read MSS.

Clearing the Status Byte

No method is provided for forcibly clearing all the bits in the status byte. Bits which are cleared are shown below.

- **When an Query is Made Using the *STB? Query**
No bit is cleared.
- **When a Serial Poll is Performed**
Only the RQS bit is cleared.
- **When the *CLS Command is Received**
When the *CLS command is received, the status byte itself is not cleared, but the contents of the standard event register (which affects the bits in the status byte) are cleared. As a result, the corresponding bits in the status byte are cleared, except bit 4 (MAV), since the output queue cannot be emptied by the *CLS command. However, the output queue will also be cleared if the *CLS command is received just after a program message terminator.

6.3 Standard Event Register

Overview of the Standard Event Register

7	6	5	4	3	2	1	0
PON	URQ	CME	EXE	DDE	QYER	QCO	PC

Bit 7 PON (Power ON)

Bit 7 PON (Power ON) Set to "1" when power is turned ON

Bit 6 URQ (User Request)

Not used (always "0")

Bit 5 CME (Command Error)

Set to "1" when the command syntax is incorrect.

Examples: Incorrectly spelled command name; "9" used in octal data.

Bit 4 EXE (Execution Error)

Set to "1" when the command syntax is correct but the command cannot be executed in the current state.

Examples: Parameters are outside the setting range; an attempt is made to make a hard copy during acquisition.

Bit 3 DDE (Device Dependent Error)

Set to "1" when execution of the command is not possible due to an internal problem in the instrument that is not a command error or an execution error.

Example: The circuit breaker is reset.

Bit 2 QYE (Query Error)

Set to "1" if the output queue is empty or if the data is missing even after a query has been sent.

Examples: No response data; data is lost due to an overflow in the output queue.

Bit 1 RQC (Request Control)

Not used (always "0")

Bit 0 OPC (Operation Complete)

Set to "1" when the operation designated by the *OPC command has been completed. Refer to Chapter 5.

Bit Masking

To mask a bit in the standard event register so that it does not cause bit 5 (ESB) of the status byte to change, set the corresponding bit in the standard event enable register to "0."

For example, to mask bit 2 (QYE) so that ESB will not be set to "1," even if a query error occurs, set bit 2 of the standard event enable register to "0." This can be done using the *ESE command. To inquire whether each bit of the standard event enable register is "1" or "0," use the *ESE?. For details of the *ESE command, refer to Chapter 5.

6.3 Standard Event Register/6.4 Extended Event Register

Operation of the Standard Event Register

The standard event register is provided for eight different kinds of event which can occur inside the instrument. Bit 5 (ESB) of the status byte is set to "1" when any of the bits in this register becomes "1" (or when the corresponding bit of the standard event enable register becomes "1").

Examples

1. A query error occurs.
2. Bit 2 (QYE) is set to "1."
3. Bit 5 (ESB) of the status byte is set to "1" if bit 2 of the standard event enable register is "1."

It is also possible to check what type of event has occurred inside the instrument by reading the contents of the standard event register.

Reading from the Standard Event Register

The contents of the standard event register can be read by the *ESR command. After completion of the read-out, the register will be cleared.

Clearing the Standard Event Register

The standard event register is cleared in the following three cases.

- When the contents of the standard event register are read using *ESR?
- When the *CLS command is received
- When power is turned ON again

6.4 Extended Event Register

Reading the extended event register tells you whether changes in the condition register (reflecting internal conditions) have occurred. A filter can be applied which allows you to decide which events are reported to the extended event register.

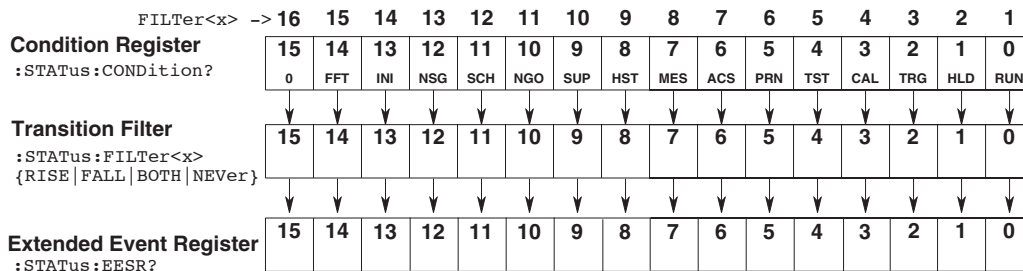

The meaning of each bit of the condition register is as follows.

Bit 0 RUN (Running)	Set to "1" during acquisition.
Bit 1 HLD (Hold)	Set to "1" for waveforms loaded from a storage medium.
Bit 2 TRG (Awaiting Trigger)	Set to "1" when waiting for a trigger.
Bit 3 CAL (Calibrating)	Set to "1" during calibration.
Bit 4 TST (Testing)	Set to "1" during self-test.
Bit 5 PRN (Printing)	Set to "1" while the built-in printer is in operation, data is being output to the external printer(USB or network printer), or screen image data is being stored.
Bit 6 ACS (Accessing)	Sets to "1" while the floppy disk drive, PC card interface, USB storage, or network drive is being accessed.
Bit 7 MES (Measuring)	Set to "1" when automated measurement of waveform parameters or cursor measurement is in progress.
Bit 8 HST (History Search)	Set to "1" while executing history search.
Bit 9 SUP (Setup)	Set to "1" during auto setup.
Bit 10 NGO (Go/No-Go)	Set to "1" while performing GO/NO-GO determination.
Bit 11 SCH (Search)	Set to "1" while executing edge/pattern search.
Bit 12 NSG (N-Single)	Set to "1" during single(N) trigger mode all waveform display, or history all waveform display.
Bit 13 INI (Initializing)	Sets to "1" during initialization.
Bit 14 FFT	Set to "1" during FFT calculation or user-defined computation.

The filter is applied to each bit of the condition register separately, and can be selected from the following.

Note that the numbering of the bits used in the filter setting differs from the actual bit number (1 to 16 vs. 0 to 15).

Rise	The bit of the extended event register becomes "1" when the bit of the condition register changes from "0" to "1."
Fall	The bit of the extended event register becomes "1" when the bit of the condition register changes from "1" to "0."
Both	The bit of the extended event register becomes "1" when the bit of the condition register changes from "0" to "1," or from "1" to "0."
Never	The bit of the extended event register is disabled and always "0."

6.5 Output Queue and Error Queue

Overview of the Output Queue

The output queue is provided to store response messages to queries. For example, when the `:WAVEform:SEND?` query is sent to request output of the acquired waveform, the response data will be stored in the output queue until it is read out. The example below shows that data is stored record by record in the output queue, and is read out oldest item first, newest item last. The output queue is emptied in the following cases (in addition to when read-out is performed).

- When a new message is received from the controller
- When dead lock occurs (page 4-2)
- When a device clear command (DCL or SDC) is received
- When power is turned ON again

The output queue cannot be emptied using the `*CLS` command. To see whether the output queue is empty or not, check bit 4 (MAV) of the status byte.

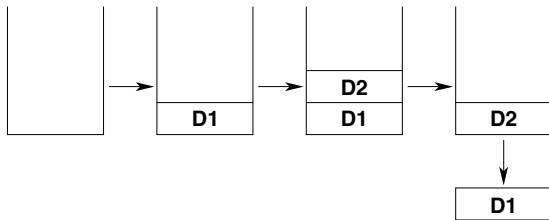

Overview of the Error Queue

The error queue stores the error No. and message when an error occurs. For example, if the controller sends an incorrect program message, the number, "113, "Undefined header"," and the error message are stored in the error queue, when the error is displayed. The contents of the error queue can be read using the `:STATus:ERROR?` query. As with the output queue, messages are read oldest first, newest last (refer to the previous page).

If the error queue becomes full, the final message will be replaced by message "350, "Queue overflow"."

The error queue is emptied in the following cases (in addition to when read-out is performed).

- When the `*CLS` command is received
- When power is turned ON again

To see whether the error queue is empty or not, check bit 2 (EAV) of the status byte.

Chapter 7 Sample Program

Notes on Use of the Sample Program

Yokogawa shall accept no responsibility whatsoever for any problems occurring as a result of use of the sample program.

7.1 Before Programming

Environment

Model: MS-DOS/V Computer
Language: Visual BASIC Ver. 6.0 Professional Edition or more
GP-IB board: PCI-GPIB IEEE-488.2 board from National Instruments.
USB interface: Conforms to USB Rev.1.0

Setting up the Visual Basic

Standardmodule: tmctl.bas
tmval.bas

Setting up the DL1720E/DL1740E/DL1740EL

GP-IB

All the sample programs given in this chapter use address 1 for the instrument, so be sure to assign the instrument to address 1 as described on page 1-5.

USB

All sample programs in this chapter were created with USB OwnID set to 1 on the main unit. Enter this setting by following the instructions on page 2-4 of the user's manual.

Note

The sample programs can be download from the following Web page.
<http://www.yokogawa.com/tm/tm-softdownload.htm>

7.2 Image of Sample Program

7.2 Image of Sample Program

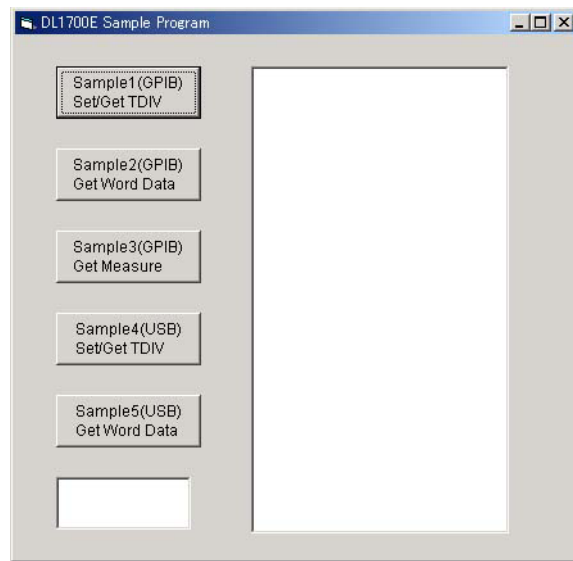

7.3 Initialize/Error/Execute

```

-----
Option Explicit
Dim StartFlag As Integer           'Start Flag
Dim Dev As Long                   'Device ID
Dim Query(3) As String            'Query String
Dim WaveBuffer(20070) As Integer  'WaveData Buffer(GPIB)
-----

Private Function InitGpib() As Long
    Dim address As String          'GPIB Address
    Dim eos As Long               'EOS
    Dim eot As Long               'EOI
    Dim timeout As Long           'Timeout
    Dim sts As Long

    address = "1"                 'Address = 1
    eos = TERM_LF                 'Terminator = LF
    eot = SET_TRUE                'EOI = Enable
    timeout = 100                 'Timeout = 10s

    sts = TmInitialize(1, address, Dev) 'GPIB Initialize(GPIB Address = 1)
    If (sts <> CTL_OK) Then
        Call DisplayError(Dev)
        InitGpib = 1
        Exit Function
    End If

    sts = TmDeviceClear(Dev)      'GPIB Device Clear
    If (sts <> CTL_OK) Then
        Call DisplayError(Dev)
        InitGpib = 1
        GoTo PostProcces
    End If

    sts = TmSetTerm(Dev, eos, eot) 'Terminator = LF, EOI = Enable
    If (sts <> CTL_OK) Then
        Call DisplayError(Dev)
        InitGpib = 1
        GoTo PostProcces
    End If

    sts = TmSetTimeout(Dev, timeout) 'Timeout = 10s
    If (sts <> CTL_OK) Then
        Call DisplayError(Dev)
        InitGpib = 1
        GoTo PostProcces
    End If
    InitGpib = 0
    Exit Function

PostProcces:
    Call CloseDevice              'Device Clear
End Function
-----

Private Function InitUsb() As Long
    Dim id As String              'USB ID
    Dim eos As Long              'EOS
    Dim eot As Long              'EOI
    Dim timeout As Long          'Timeout
    Dim sts As Long

    id = "1"                      'ID = 1
    eos = TERM_LF                 'Terminator = LF
    eot = SET_TRUE                'EOI = None(GPIB Only)
    timeout = 100                 'Timeout = 10s

    sts = TmInitialize(3, id, Dev) 'USB Initialize(USB ID = 1)
    If (sts <> CTL_OK) Then
        Call DisplayError(Dev)
        InitUsb = 1
        Exit Function
    End If

    sts = TmSetTerm(Dev, eos, eot) 'Terminator = LF, EOI = Enable
    If (sts <> CTL_OK) Then
        Call DisplayError(Dev)
        InitUsb = 1
        GoTo PostProcces
    End If

    sts = TmSetTimeout(Dev, timeout) 'Timeout = 10s
    If (sts <> CTL_OK) Then
        Call DisplayError(Dev)
        InitUsb = 1
        GoTo PostProcces
    End If
    InitUsb = 0
    Exit Function

```

7.3 Initialize/Error/Execute

```
PostProces:
  Call CloseDevice                                'Device Clear
End Function
-----
Private Sub CloseDevice()
  Call TmFinish(Dev)
  Dev = -1
End Sub
-----
Private Sub DisplayError(ByVal id As Long)
  Dim ers As String
  Dim err As Long

  err = TmGetLastError(id)                        'Get Error No.
  If (err = 2) Then
    ers = "Device not found"
  ElseIf (err = 4) Then
    ers = "Connection to device failed"
  ElseIf (err = 8) Then
    ers = "Device not connected"
  ElseIf (err = 16) Then
    ers = "Device already connected"
  ElseIf (err = 32) Then
    ers = "Incompatible PC"
  ElseIf (err = 64) Then
    ers = "Illegal parameter"
  ElseIf (err = 256) Then
    ers = "Send error"
  ElseIf (err = 512) Then
    ers = "Receive error"
  ElseIf (err = 1024) Then
    ers = "Received data not block data"
  ElseIf (err = 4096) Then
    ers = "System error"
  ElseIf (err = 8192) Then
    ers = "Illegal device ID"
  Else
    ers = ""
  End If

  MsgBox ("Error No. " + Str(err) + Chr(13) + ers), vbExclamation, "Error!"
End Sub
-----
Private Sub Command1_Click()
  Dim sts As Long

  If (StartFlag = 1) Then
    Exit Sub
  End If
  StartFlag = 1
  Text1.Text = "START"
  List1.Clear
  sts = GpibTdiv                                  'Run Sample1(GPIB) Set/Get TDIV
  If (sts = 0) Then
    List1.AddItem Query(0)
  End If
  Text1.Text = "END"
  StartFlag = 0
End Sub
-----
Private Sub Command2_Click()
  Dim sts As Long

  If (StartFlag = 1) Then
    Exit Sub
  End If
  StartFlag = 1
  Text1.Text = "START"
  List1.Clear
  sts = GpibGetWord                               'Run Sample2(GPIB) Get Word Data
  If (sts = 0) Then
    List1.AddItem "END"
  End If
  Text1.Text = "END"
  StartFlag = 0
End Sub
-----
Private Sub Command3_Click()
  Dim sts As Integer

  If (StartFlag = 1) Then
    Exit Sub
  End If
  StartFlag = 1
  Text1.Text = "START"
  List1.Clear
  sts = GpibGetMeasure                             'Run Sample3(GPIB) Get Measure
  If (sts = 0) Then
    List1.AddItem Query(0)
    List1.AddItem Query(1)
    List1.AddItem Query(2)
  End If
End Sub
```

```

ElseIf (sts = 2) Then
    List1.AddItem "Waiting for Trigger!"
End If
Text1.Text = "END"
StartFlag = 0
End Sub
-----
Private Sub Command4_Click()
    Dim sts As Long

    If (StartFlag = 1) Then
        Exit Sub
    End If
    StartFlag = 1
    Text1.Text = "START"
    List1.Clear
    sts = UsbTdiv                                     'Run Sample4(USB) Set/Get TDIV
    If (sts = 0) Then
        List1.AddItem Query(0)
    End If
    Text1.Text = "END"
    StartFlag = 0
End Sub
-----
Private Sub Command5_Click()
    Dim sts As Long

    If (StartFlag = 1) Then
        Exit Sub
    End If
    StartFlag = 1
    Text1.Text = "START"
    List1.Clear
    sts = UsbGetWord                                  'Run Sample5(USB) Get Word Data
    If (sts = 0) Then
        List1.AddItem "END"
    End If
    Text1.Text = "END"
    StartFlag = 0
End Sub
-----
Private Sub Form_Load()
    StartFlag = 0                                     'Clear Start Flag
    Dev = -1                                         'Clear device id
    Command1.Caption = "Sample1(GPIB)" + Chr(13) + "Set/Get TDIV"
    Command2.Caption = "Sample2(GPIB)" + Chr(13) + "Get Word Data"
    Command3.Caption = "Sample3(GPIB)" + Chr(13) + "Get Measure"
    Command4.Caption = "Sample4(USB)" + Chr(13) + "Set/Get TDIV"
    Command5.Caption = "Sample5(USB)" + Chr(13) + "Get Word Data"
    Text1.Text = ""
End Sub
-----

```

7.4 Sets/Queries the T/Div

```

Sample1(GPIB) Set/Get TDIV
-----
Private Function GpibTdiv() As Long
    Dim sts As Long

    sts = InitGpib                                'Initialize GPIB
    If (sts <> 0) Then
        GpibTdiv = 1
        Exit Function
    End If

    sts = GetTdiv                                  'T/DIV Function
    If (sts <> 0) Then
        GpibTdiv = 1
        GoTo GpibTdivEnd
    End If
    GpibTdiv = 0

GpibTdivEnd:
    Call CloseDevice                              'Device Close
End Function
-----
Sample4(USB) Set/Get TDIV
-----
Private Function UsbTdiv() As Long
    Dim sts As Integer

    sts = InitUsb                                  'Initialize USB
    If (sts <> 0) Then
        UsbTdiv = 1
        Exit Function
    End If

    sts = GetTdiv                                  'T/DIV Function
    If (sts <> 0) Then
        UsbTdiv = 1
        GoTo UsbTdivEnd
    End If
    UsbTdiv = 0

UsbTdivEnd:
    Call CloseDevice                              'Device Close
End Function
-----
Private Function GetTdiv() As Long
    Dim msg As String                              'Command buffer
    Dim qry As String                              'Query biffer
    Dim sts As Long
    Dim rlen As Long

    msg = Space$(100)
    qry = Space$(100)

    msg = "TIMEBASE:TDIV 2ms"                    'Set T/div = 2ms
    sts = TmSend(Dev, msg)                        'Send Command
    If (sts <> CTL_OK) Then
        Call DisplayError(Dev)
        GetTdiv = 1
        Exit Function
    End If

    msg = "TIMEBASE:TDIV?"                        'Get T/div value
    sts = TmSend(Dev, msg)                        'Send Command
    If (sts <> CTL_OK) Then
        Call DisplayError(Dev)
        GetTdiv = 1
        Exit Function
    End If

    sts = TmReceive(Dev, qry, Len(qry), rlen)     'Receive Query
    If (sts <> CTL_OK) Then
        Call DisplayError(Dev)
        GetTdiv = 1
        Exit Function
    End If
    Query(0) = Left(qry, rlen - 1)
    GetTdiv = 0
End Function
-----

```

GP-IB

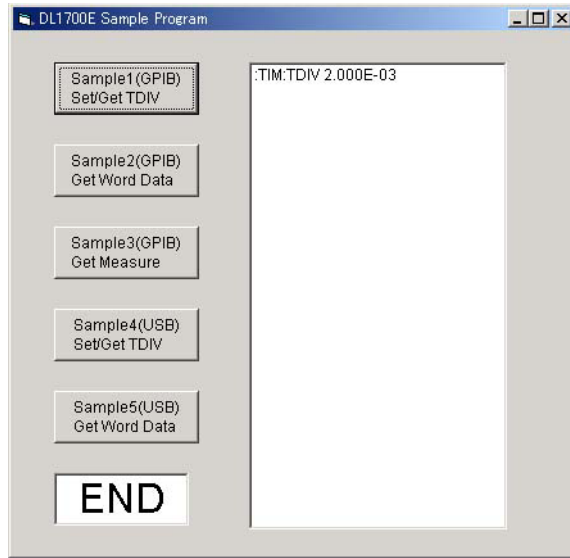

USB

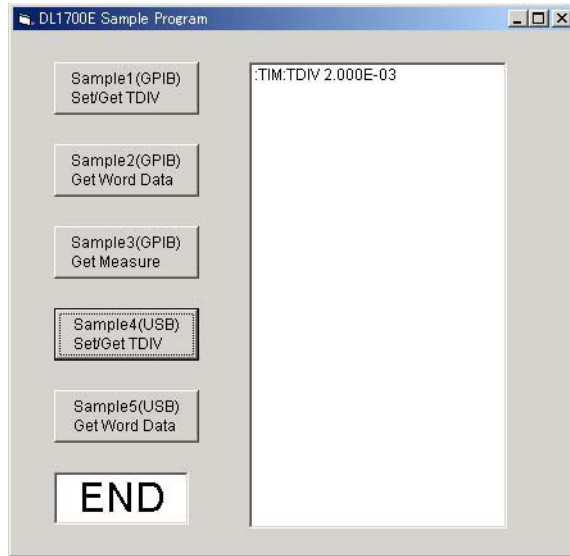

7.5 Data Output in Word Format (2 bytes)

7.5 Data Output in Word Format (2 bytes)

```
Sample2(GPIB) Get Word Data
-----
Private Function GpibGetWord() As Long
    Dim sts As Long

    sts = InitGpib                                'Initialize GPIB
    If (sts <> 0) Then
        GpibGetWord = 1
        Exit Function
    End If

    sts = GetWord                                  'Get Word Data Function
    If (sts <> 0) Then
        GpibGetWord = 1
        GoTo GpibGetWordEnd
    End If
    GpibGetWord = 0

GpibGetWordEnd:
    Call CloseDevice                              'Device Close
End Function
-----
Sample5(USB) Get Word Data
-----
Private Function UsbGetWord() As Integer
    Dim sts As Long

    sts = InitUsb                                  'Initialize USB
    If (sts <> 0) Then
        UsbGetWord = 1
        Exit Function
    End If

    sts = GetWord                                  'Get Word Data Function
    If (sts <> 0) Then
        UsbGetWord = 1
        GoTo UsbGetWordEnd
    End If
    UsbGetWord = 0

UsbGetWordEnd:
    Call CloseDevice                              'Device Close
End Function
-----
Private Function GetWord() As Long
    Dim msg As String                             'Command buffer
    Dim qry As String                             'Query biffer
    Dim sts As Long
    Dim vdv As Variant                            'Vdiv value
    Dim ofs As Variant                            'Offset value
    Dim dlq As Long                               'Block Data Length
    Dim dat As Variant                            'Data
    Dim i As Integer
    Dim rlen As Long
    Dim endflag As Long

    msg = Space$(100)
    qry = Space$(100)

    msg = "STOP"                                  'Stop Acquisition
    sts = TmSend(Dev, msg)
    If (sts < CTL_OK) Then
        Call DisplayError(Dev)
        GetWord = 1
        Exit Function
    End If

    msg = "COMMUNICATE:HEADER OFF"                'Query Header Off(for Get V/div)
    sts = TmSend(Dev, msg)
    If (sts <> CTL_OK) Then
        Call DisplayError(Dev)
        GetWord = 1
        Exit Function
    End If

    msg = "WAVEFORM:TRACE 1"                      'Trace = 1
    sts = TmSend(Dev, msg)
    If (sts <> CTL_OK) Then
        Call DisplayError(Dev)
        GetWord = 1
        Exit Function
    End If
End If
```



```

msg = "WAVEFORM:RECORD 0"           'Record number = 0
sts = TmSend(Dev, msg)
If (sts <> CTL_OK) Then
    Call DisplayError(Dev)
    GetWord = 1
    Exit Function
End If

msg = "WAVEFORM:FORMAT WORD"       'Data Format = WORD
sts = TmSend(Dev, msg)
If (sts <> CTL_OK) Then
    Call DisplayError(Dev)
    GetWord = 1
    Exit Function
End If

msg = "WAVEFORM:BYTEORDER LSBFIRST" 'Data Byte order = LSB First(for
Little Endian)
sts = TmSend(Dev, msg)
If (sts <> CTL_OK) Then
    Call DisplayError(Dev)
    GetWord = 1
    Exit Function
End If

msg = "WAVEFORM:START 0;END 1001"  'START 0,END 1001(Length = 1002)
sts = TmSend(Dev, msg)
If (sts <> CTL_OK) Then
    Call DisplayError(Dev)
    GetWord = 1
    Exit Function
End If

msg = "WAVEFORM:RANGE?"            'Get V/div value
sts = TmSend(Dev, msg)
If (sts <> CTL_OK) Then
    Call DisplayError(Dev)
    GetWord = 1
    Exit Function
End If
sts = TmReceive(Dev, qry, Len(qry), rlen)
If (sts <> CTL_OK) Then
    Call DisplayError(Dev)
    GetWord = 1
    Exit Function
End If
vdv = Val(qry)

msg = "WAVEFORM:OFFSET?"           'Get Offset value
sts = TmSend(Dev, msg)
If (sts <> CTL_OK) Then
    Call DisplayError(Dev)
    GetWord = 1
    Exit Function
End If
sts = TmReceive(Dev, qry, Len(qry), rlen)
If (sts <> CTL_OK) Then
    Call DisplayError(Dev)
    GetWord = 1
    Exit Function
End If
ofs = Val(qry)

msg = "WAVEFORM:SEND?"             'Receive Waveform Data
sts = TmSend(Dev, msg)
If (sts <> CTL_OK) Then
    Call DisplayError(Dev)
    GetWord = 1
    Exit Function
End If
sts = TmReceiveBlockHeader(Dev, dlq) 'Receive Block Header
If (sts <> CTL_OK) Then
    Call DisplayError(Dev)
    GetWord = 1
    Exit Function
End If
sts = TmReceiveBlock(Dev, WaveBuffer(), dlq + 1, rlen, endflag) 'dlq = Data Byte Length
'Receive Waveform Data + LF

If (sts <> CTL_OK) Then
    Call DisplayError(Dev)
    GetWord = 1
    Exit Function
End If

For i = 0 To (dlq / 2 - 1) Step 1
    dat = WaveBuffer(i) * vdv / 3072 + ofs
    List1.AddItem CStr(i) + ":" + CStr(dat)
Next i

```

7.5 Data Output in Word Format (2 bytes)

```
msg = "COMMUNICATE:HEADER ON"           'Query Header On
sts = TmSend(Dev, msg)
If (sts < CTL_OK) Then
  Call DisplayError(Dev)
  GetWord = 1
  Exit Function
End If
GetWord = 0
End Function
```

GP-IB

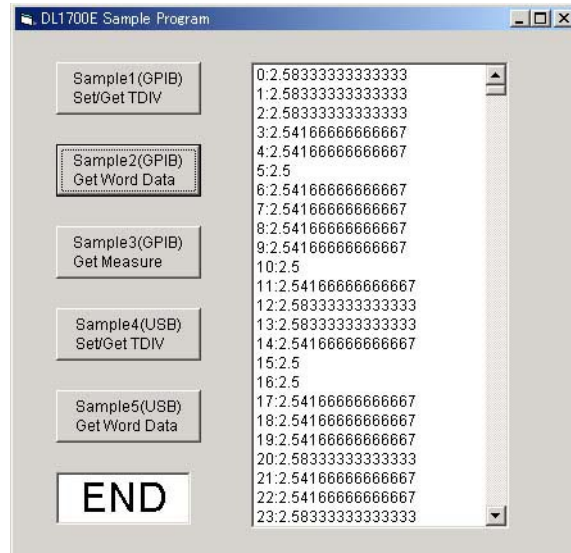

USB

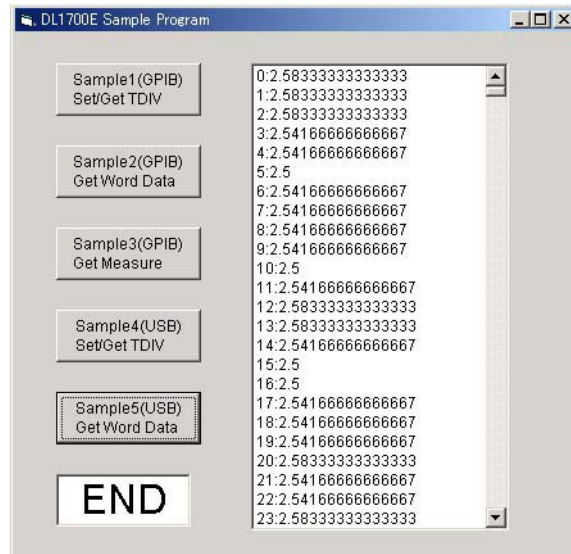

7.6 Sets/Queries Measure Value

```

Sample3(GPIB) Get Measure value
-----
Private Function GpibGetMeasure() As Long
    Dim sts As Long

    sts = InitGpib                                'Initialize GPIB
    If (sts <> 0) Then
        GpibGetMeasure = 1
        Exit Function
    End If

    sts = GetMeasure                              'Get Measure Function
    If (sts <> 0) Then
        GpibGetMeasure = 1
        GoTo GpibGetMeasureEnd
    End If
    GpibGetMeasure = 0

GpibGetMeasureEnd:
    Call CloseDevice                              'Device Close
End Function
-----
Private Function GetMeasure() As Long
    Dim msg As String                            'Command buffer
    Dim qry As String                            'Query biffer
    Dim sts As Long
    Dim stp As Integer
    Dim rlen As Long

    msg = Space$(100)
    qry = Space$(100)

    msg = "STOP"                                'Acquisition = Stop
    sts = TmSend(Dev, msg)
    If (sts <> CTL_OK) Then
        Call DisplayError(Dev)
        GetMeasure = 1
        Exit Function
    End If

    msg = "COMMUNICATE:HEADER OFF"              'Query Header Off(for Get V/div)
    sts = TmSend(Dev, msg)
    If (sts <> CTL_OK) Then
        Call DisplayError(Dev)
        GetMeasure = 1
        Exit Function
    End If

    msg = "MEASURE:MODE OFF"                    'Measure Off
    sts = TmSend(Dev, msg)
    If (sts <> CTL_OK) Then
        Call DisplayError(Dev)
        GetMeasure = 1
        Exit Function
    End If

    msg = "CHANNEL:DISPLAY ON"                  'CH1 On
    sts = TmSend(Dev, msg)
    If (sts <> CTL_OK) Then
        Call DisplayError(Dev)
        GetMeasure = 1
        Exit Function
    End If

    msg = "CHANNEL:PROBE 10"                    'CH1 Probe = 10:1
    sts = TmSend(Dev, msg)
    If (sts <> CTL_OK) Then
        Call DisplayError(Dev)
        GetMeasure = 1
        Exit Function
    End If

    msg = "CHANNEL:VDIV 500mV"                  'CH1 V/div = 500mV
    sts = TmSend(Dev, msg)
    If (sts <> CTL_OK) Then
        Call DisplayError(Dev)
        GetMeasure = 1
        Exit Function
    End If

    msg = "ACQUIRE:MODE NORMAL;RLENGTH 1000"  'Acquisition mode = NORMAL, length =
1000
    sts = TmSend(Dev, msg)
    If (sts <> CTL_OK) Then
        Call DisplayError(Dev)
        GetMeasure = 1
        Exit Function
    End If
End If

```

7.6 Sets/Queries Measure Value

```
msg = "TIMEBASE:TDIV 100ms"           'T/div = 100ms
sts = TmSend(Dev, msg)
If (sts <> CTL_OK) Then
    Call DisplayError(Dev)
    GetMeasure = 1
    Exit Function
End If

msg = "TRIGGER:SIMPLE:LEVEL 500mV"    'Trigger level = 500mV
sts = TmSend(Dev, msg)
If (sts <> CTL_OK) Then
    Call DisplayError(Dev)
    GetMeasure = 1
    Exit Function
End If

msg = "MEASURE:CHANNEL1:PTOPEAK:STATE ON" 'Measure P-P On
sts = TmSend(Dev, msg)
If (sts <> CTL_OK) Then
    Call DisplayError(Dev)
    GetMeasure = 1
    Exit Function
End If

msg = "MEASURE:CHANNEL1:AVERAGE:STATE ON" 'Measure Average On
sts = TmSend(Dev, msg)
If (sts <> CTL_OK) Then
    Call DisplayError(Dev)
    GetMeasure = 1
    Exit Function
End If

msg = "MEASURE:CHANNEL1:FREQUENCY:STATE ON" 'Measure Frequency On
sts = TmSend(Dev, msg)
If (sts <> CTL_OK) Then
    Call DisplayError(Dev)
    GetMeasure = 1
    Exit Function
End If

msg = "MEASURE:TRANGE -5,5"          'Measure Time Range -5,5
sts = TmSend(Dev, msg)
If (sts <> CTL_OK) Then
    Call DisplayError(Dev)
    GetMeasure = 1
    Exit Function
End If

msg = "SSTART? 500"                  'Start Single Trigger
sts = TmSend(Dev, msg)                'Wait until stop Acquisition
If (sts <> CTL_OK) Then
    Call DisplayError(Dev)
    GetMeasure = 1
    Exit Function
End If
sts = TmReceive(Dev, qry, Len(qry), rlen)
If (sts <> CTL_OK) Then
    Call DisplayError(Dev)
    GetMeasure = 1
    Exit Function
End If
stp = Val(qry)
If (stp = 1) Then
    GetMeasure = 2
    Exit Function
End If

msg = "MEASURE:MODE ON"               'Start Measure
sts = TmSend(Dev, msg)
If (sts <> CTL_OK) Then
    Call DisplayError(Dev)
    GetMeasure = 1
    Exit Function
End If
msg = "MEASURE:WAIT? 100"             'Wait until stop Measure
sts = TmSend(Dev, msg)
If (sts <> CTL_OK) Then
    Call DisplayError(Dev)
    GetMeasure = 1
    Exit Function
End If
sts = TmReceive(Dev, qry, Len(qry), rlen)
If (sts <> CTL_OK) Then
    Call DisplayError(Dev)
    GetMeasure = 1
    Exit Function
End If
```

```

msg = "MEASURE:CHANNEL1:PTOPEAK:VALUE?"      'Get P-P value
sts = TmSend(Dev, msg)
If (sts <> CTL_OK) Then
  Call DisplayError(Dev)
  GetMeasure = 1
  Exit Function
End If
sts = TmReceive(Dev, qry, Len(qry), rlen)
If (sts <> CTL_OK) Then
  Call DisplayError(Dev)
  GetMeasure = 1
  Exit Function
End If
Query(0) = "Peak To Peak:" + Left$(qry, rlen - 1)

msg = "MEASURE:CHANNEL1:AVERAGE:VALUE?"      'Get Average value
sts = TmSend(Dev, msg)
If (sts <> CTL_OK) Then
  Call DisplayError(Dev)
  GetMeasure = 1
  Exit Function
End If
sts = TmReceive(Dev, qry, Len(qry), rlen)
If (sts <> CTL_OK) Then
  Call DisplayError(Dev)
  GetMeasure = 1
  Exit Function
End If
Query(1) = "Average:" + Left$(qry, rlen - 1)

msg = "MEASURE:CHANNEL1:FREQUENCY:VALUE?"    'Get Freq value
sts = TmSend(Dev, msg)
If (sts <> CTL_OK) Then
  Call DisplayError(Dev)
  GetMeasure = 1
  Exit Function
End If
sts = TmReceive(Dev, qry, Len(qry), rlen)
If (sts <> CTL_OK) Then
  Call DisplayError(Dev)
  GetMeasure = 1
  Exit Function
End If
Query(2) = "Frequency:" + Left$(qry, rlen - 1)

msg = "COMMUNICATE:HEADER ON"                'Query Header On
sts = TmSend(Dev, msg)
If (sts <> CTL_OK) Then
  Call DisplayError(Dev)
  GetMeasure = 1
  Exit Function
End If
GetMeasure = 0
End Function

```

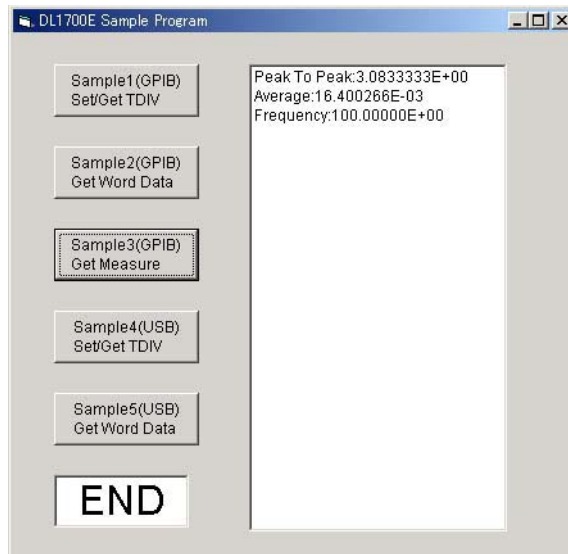

Appendix

Appendix 1 ASCII Character Code

ASCII character codes are given below.

	0	1	2	3	4	5	6	7
0	0 NUL	20 DEL	40 SP	60 0	100 @	120 P	140 '	160 p
1	1 SOH	21 DC1	41 !	61 1	101 A	121 Q	141 a	161 q
2	2 STX	22 DC2	42 "	62 2	102 B	122 R	142 b	162 r
3	3 ETX	23 DC3	43 #	63 3	103 C	123 S	143 c	163 s
4	4 EOT	24 DC4	44 \$	64 4	104 D	124 T	144 d	164 t
5	5 ENQ	25 NAK	45 %	65 5	105 E	125 U	145 e	165 u
6	6 ACK	26 SYN	46 &	66 6	106 F	126 V	146 f	166 v
7	7 BEL	27 ETB	47 ,	67 7	107 G	127 W	147 g	167 w
8	10 BS	30 CAN	50 (70 8	110 H	130 X	150 h	170 x
9	11 HT	31 EM	51)	71 9	111 I	131 Y	151 i	171 y
A	12 LF	32 SUB	52 *	72 :	112 J	132 Z	152 j	172 z
B	13 VT	33 ESC	53 +	73 ;	113 K	133 [153 k	173 {
C	14 FF	34 FS	54 ,	74 <	114 L	134 \	154 l	174
D	15 CR	35 GS	55 -	75 =	115 M	135]	155 m	175 }
E	16 SO	36 RS	56 .	76 >	116 N	136 ^	156 n	176 ~
F	17 SI	37 US	57 /	77 ?	117 O	137 _	157 o	177 DEL (RUBOUT)
	Address Command	Universal Command	Listener Address		Talker Address		Secondary Command	

Example

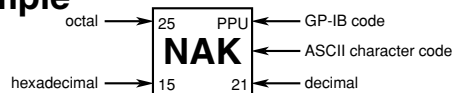

Appendix 2 Error Messages

Error messages related to communications are given below.

- The instrument allows error messages to be displayed in either Japanese or English, however, they are shown only in English when they are displayed on a personal computer.
- When servicing is required, contact your nearest YOKOGAWA representative.
- Only error messages relating to communications are given. For other error messages, refer to the User's Manual IM 701730-01E.

Errors in Communication Command (100 to 199)

Code	Message	Action	Reference Page
102	Syntax error.	Incorrect syntax.	Chapter 4, 5
103	Invalid separator.	Insert a comma between data items to separate them.	4-1
104	Data type error.	Refer to pages 5-5 to 5-6 and enter using the correct data format.	4-5 to 4-6
105	GET not allowed.	GET is not supported as response to an interface message.	1-9
108	Parameter not allowed.	Check the number of parameters.	4-5, Chapter 5
109	Missing parameter.	Enter required parameters.	4-5, Chapter 5
111	Header separator error.	Insert a space between header and data to separate them.	4-1
112	Program mnemonic too long.	Check the mnemonic (a character string consisting of letters and numbers).	Chapter 5
113	Undefined header.	Check the header.	Chapter 5
114	Header suffix out of range.	Check the header.	Chapter 5
120	Numeric data error.	Numeric value must be entered for <NRf> format.	4-5
123	Exponent too large.	Use a smaller exponent for <NR3> format.	4-5, Chapter 5
124	Too many digits.	Limit the number of digits to 255 or less.	4-5, Chapter 5
128	Numeric data not allowed.	Enter in a format other than <NRf> format.	4-5, Chapter 5
131	Invalid suffix.	Check the unit for <Voltage>, <Time> and <Frequency>.	4-5
134	Suffix too long.	Check the units for <Voltage>, <Time> and <Frequency>.	4-5
138	Suffix not allowed.	No units are allowed other than <Voltage>, <Time> and <Frequency>.	4-5
141	Invalid character data.	Enter one of the character strings in {...}.	Chapter 5
144	Character data too long.	Check the character strings in {...}.	Chapter 5
148	Character data not allowed.	Enter in a format other than in {...}.	Chapter 5
150	String data error.	<Character string> must be enclosed by double quotation marks or apostrophes.	4-6
151	Invalid string data.	<Character string> is too long or contains characters which cannot be used.	Chapter 5
158	String data not allowed.	Enter in a data format other than <Character string>.	Chapter 5
161	Invalid block data.	<Block data> is not allowed.	4-6, Chapter 5
168	Block data not allowed.	<Block data> is not allowed.	4-6, Chapter 5
171	Invalid expression.	Equation is not allowed.	Chapter 5
178	Expression data not allowed.	Equation is not allowed.	Chapter 5
181	Invalid outside macro definition.	Does not conform to the macro function specified in IEEE488.2.	—

Error in Communication Execution (200 to 299)

Code	Message	Action	Reference Page
221	Setting conflict.	Check the relevant setting.	Chapter 5
222	Data out of range.	Check the setting range.	Chapter 5
223	Too much data.	Check the data byte length.	Chapter 5
224	Illegal parameter value.	Check the setting range.	Chapter 5
241	Hardware missing.	Check availability of options.	—
260	Expression error.	Equation is not allowed.	—
270	Macro error.	Does not conform to the macro function specified in IEEE488.2.	—
272	Macro execution error.	Does not conform to the macro function specified in IEEE488.2.	—
273	Illegal macro label.	Does not conform to the macro function specified in IEEE488.2.	—
275	Macro definition too long.	Does not conform to the macro function specified in IEEE488.2.	—
276	Macro recursion error.	Does not conform to the macro function specified in IEEE488.2.	—
277	Macro redefinition not allowed.	Does not conform to the macro function specified in IEEE488.2.	—
278	Macro header not found.	Does not conform to the macro function specified in IEEE488.2.	—

Error in Communications Query (400 to 499)

Code	Message	Action	Reference Page
410	Query INTERRUPTED.	Check transmission/reception order.	4-2
420	Query UNTERMINATED.	Check transmission/reception order.	4-2
430	Query DEADLOCKED.	Limit the length of the program message including <PMT> to 1024 bytes or less.	4-2
440	Query UNTERMINATED after indefinite response.	Do not enter any query after *IDN? and *OPT?.	—

Error in System Operation (912)

Code	Message	Action	Reference Page
912	Fatal error in the communication driver.	Servicing is required.	—

Warning (50)

Code	Message	Action	Reference Page
50	*OPC/? exists in message.	Place the *OPC or *OPC? at the end of the program message.	—

Other Errors (350)

Code	Message	Action	Reference Page
350	Queue overflow.	Read the error queue. Code 350 occurs when the error queue is full up. This message is output only for the :STATus:ERRor?query and is not displayed on the screen.	6-5

Note

Code 350 indicates overflow of error queue. This code is returned as a response to the " :STATus:ERRor?query; it does not appear on the screen.

Appendix 3 Overview of IEEE 488.2-1992

The GP-IB interface provided with DL1720E/DL1740E/DL1740EL conforms to IEEE 488.2-1992. This standard requires the following 23 points be stated in this document. This Appendix describes these points.

1 Subsets Supported by IEEE 488.1 Interface Functions

Refer to Section 1.4 "GP-IB Interface Specifications".

2 Operation of Device when the Device is Assigned to an Address Other than Addresses 0 to 30.

The DL1720E/DL1740E/DL1740EL does not allow assignment to an address other than 0 to 30.

3 Reaction when the User Changes the Address

The current address is changed when a new address is set using **MISC**. The newly set address is valid until another new address is set.

4 Device Setup at Power ON.Commands which can be Used at Power ON

Basically, the previous settings (i.e. the settings which were valid when power was turned OFF) are valid. All commands are available at power ON.

5 Message Transmission Options

a Input Buffer Size

4096 bytes

b Queries which Return Multiple Response Messages

Refer to Chapter 5, "Command List".

c Queries which Generate Response Data during Analysis of the Syntax

Every query generates a response data when analysis of the syntax is completed.

d Queries which Generate Response Data during Reception

No query generates response data when the query is received by the controller.

e Commands Consisting of Parameters which Restrict One Other

Some commands, like the `:CHANnel<x>:VOLTage:PROBe` and `VDIV`, have parameters which restrict unilaterally, but no commands have parameters which restrict bilaterally.

6 Options Included in Command Function Elements and Composite Header Elements

Refer to Chapters 4 and 5.

7 Buffer Size which Affects Transmission of Block Data

During transmission of block data, the output queue is extended according to the size of the data blocks.

8 List of Program Data Elements which can be Used in Equations, and Nesting Limit

No equations can be used.

9 Syntax of Response to Queries

Refer to the description of the commands given in Chapter 5.

10 Communications between Devices which do not Follow the Response Syntax

Not supported.

11 Size of Data Block of Response Data

1 to 16032000 bytes

12 List of Supported Common Commands

Refer to Section 5.35 “Common Command Group”.

13 Condition of Device when Calibration is Successfully Completed

Same as the one under which measurements are performed

14 Maximum Length of Block Data which can be Used for Definition of *DDT Trigger Macro

Not supported

15 Maximum Length of Macro Label Used in Definition of Macro, Maximum Length of Block Data which can be Used for Definition of Macro, Processing when Recursion is Used in Definition of Macro

Macro functions are not supported.

16 Response to *IDN?

Refer to Section 5.35 “Common Command Group”.

17 Size of Storage Area for Protected User Data for PUD and *PUD?

*PUD and *PUD? are not supported.

18 Length of *RDT and *RDT? Resource Name

*RDT and *RDT? are not supported.

19 Change in Status Due to *RST, *LRN?, *RCL and *SAV

*RST, *LRN?

Refer to Section 5.35 “Common Command Group”.

*RCL, *SAV

These commands are not supported.

20 Execution Range of Self-Test Using the *TST?

All the memory tests (for each internal memory) given in the Self Test menu displayed using **MISC** can be executed.

21 Structure of Extended Return Status

Refer to Chapter 6.

22 To Find out whether Each Command is Performed in Parallel or Sequentially

Refer to Section 4.5 “Synchronization with the Controller” and to Chapter 5.

23 Description of Execution of Each Command

Refer to Chapter 5 of this manual and to the User’s Manual IM 701730-01E.

Appendix 4 Waveform Parameter Name Correspondence Table

Appendix 4 Waveform Parameter Name Correspondence Table

Name Displayed on the Setup Menu of the DL1720E/DL1740E/DL1740EL Screen	Name Used by Communication Commands	Name on the DL1720E/DL1740E/DL1740EL Screen When Displaying Measured Results
P-P	PTOPeak	P-P
Max	MAXimum	Max
Min	MINimum	Min
Avg	AVERage	Avg
Rms	RMS	Rms
Sdev	SDEVIation	SDv
High	HIGH	High
Low	LOW	Low
+OShot	POVershoot	+Ovr
-OShot	NOVershoot	-Ovr
Freq	FREQuency	Freq
Period	PERiod	Prod
Rise	RISE	Rise
Fall	FALL	Fall
+Width	PWIDth	+Wd
-Width	NWIDth	-Wd
Duty	DUTYcycle	Duty
Burst1	BWIDth1	Bst1
Burst2	BWIDth2	Bst2
Pulse	PNUMber	PlsN
AvgFreq	AVGFreq	FR-A
AvgPeriod	AVGPeriod	PR-A
Int1TY	TY1Integ	I1TY
Int2TY	TY2Integ	I2TY
Int1XY	XY1Integ	I1XY
Int2XY	XY2Integ	I2XY
Delay	DELay	Dly

Index

Symbols

*OPC command	4-8
*WAI command	4-8

A

A -> B (n) trigger	5-104
A Delay B trigger	5-105
abbreviated form	4-5
accumulation mode	5-35
accumulation setting	5-35
ACQuire Group	5-15
acquisition count	5-16
acquisition mode	5-16
action on trigger	5-104
address	1-5
angle cursor	5-27
area of the automated measurement	5-70
ASETup Group	5-17
auto naming function	5-42
auto scroll	5-86
auto-setup	5-17
automated measurement (Dual Area)	5-76
automated measurement parameter (ON/OFF)	5-72
automated measurement value	5-74
average weight	5-16
averaging	5-16

B

backlight	5-97
binary computation	5-64
block data	4-7
Boolean	4-6
brightness	5-36

C

CALibrate Group	5-17
calibration	5-17, 5-118
CHANnel Group	5-19
channel ON/OFF	5-20
character data	4-6
character string data	4-7
CLEar Group	5-22
click sound	5-97
clock channel (parallel pattern search)	5-88
clock channel (serial pattern search)	5-89
command	4-3
Common Command Group	5-118
COMMunicate Group	5-23
condition register	5-93
connection via the Ethernet interface	3-4
continuous action	5-49
criteria status	5-88
current setting	5-119
current-to-voltage conversion ratio	5-21
cursor (X-Y display)	5-30
CURSor Group	5-25
cursor measurement	5-27
cycle statistics	5-75

D

data	4-1, 4-5
data saving	5-42
data transfer rate	1-4, 2-2, 3-2
date	5-97
deadlock	4-2
delay	5-71
determination logic (GO/NO-GO)	5-48
determination range	5-58
determination type (GO/NO-GO)	5-48
directory	5-41
display format	5-36
DISPlay Group	5-33

E

edge detection count	5-72, 5-86
edge search	5-86
enable register	6-2
error queue	6-5
Ethernet interface connector	3-1
extended event enable register	5-93
extended event register	6-4
external trigger	5-98

F

FFT computation	5-64
FILE Group	5-38
format the disk	5-41
free disk space	5-41
front panel	1-1, 2-1, 3-1

G

GO/NO-GO determination	5-47
GO/NO-GO determination (zone)	5-50
GO/NO-GO determination logic	5-48
GO/NO-GO determination type	5-48
GONogo Group	5-44
GP-IB connector	1-1
graticule	5-36
group	4-3

H

HCOPy Group	5-52
header	4-1
HF rejection	5-108
high level	5-73
historical statistical processing	5-75
HISTory Group	5-55
history memory function	5-57
history search	5-57
history search (waveform parameter)	5-57
history search (zone)	5-59
history statistics	5-75
hold off	5-106
horizontal cursor (T-Y display)	5-28
horizontal cursor (X-Y display)	5-30
hysteresis	5-107, 5-108

Index

I

ID value	2-5
IMAGe Group	5-60
INITialize Group	5-62
input coupling	5-20
input filter	5-20
instrument model	5-119
integration	5-64
interface message	1-6
interleave mode	5-16

L

LCD monitor	5-97
linear scaling	5-20
lithium battery	5-97
local	5-24
local lockout	5-23
local mode	1-3, 2-2, 3-2
long print	5-54
low level	5-73

M

magnification (long print)	5-54
mail reports sent	5-104
marker cursor (T-Y display)	5-28
marker cursor (X-Y display)	5-31
MATH Group	5-63
MEASure Group	5-66
message	4-1
minimum record number	5-58
MISC key	1-1, 2-1, 3-1
model	5-119

N

Name Correspondence Table	App-6
network printer	5-54
number of NO-GO result	5-48
number of times (trigger activated)	5-107
number of waveform acquisition (GO/NO-GO)	5-50

O

offset voltage	5-21
one-cycle mode	5-75
OR trigger	5-106
output queue	6-5
overlap command	4-8

P

parallel pattern search	5-87
password	3-6
pattern A	5-105
pattern B	5-105
pattern trigger	5-106
periodic statistical processing	5-75
PHASe Group	5-78
phase shift	5-78
physical value	5-112
preset function	5-80
PRESet Group	5-79
print (external printer)	5-53
print of screen image data	5-53
print operation	5-53

probe	5-107
probe attenuation	5-21
program message	4-1
program message unit	4-1
pulse width search	5-90
pulse width trigger	5-109

Q

queries the waveform data	5-113
query	4-1, 4-4

R

range	5-112
range over (GO/NO-GO determination)	5-50
rear panel	1-1, 2-1, 3-1
RECall Group	5-82
record length	5-16
remote	5-24
remote mode	1-3, 2-2, 3-2
repetitive sampling	5-16
reset	5-120
response	4-5
response data	4-2
response header	4-2
response message	4-1

S

sampling rate	5-99
scale conversion	5-65
screen color	5-35
screen image data save	5-61
search & zoom function	5-86
search condition (zone)	5-59
SEARCh Group	5-83
search mode	5-58
self test	5-120
sequential command	4-8
serial pattern search	5-89
serial polling	5-94
short print	5-54
single action	5-49
skew compensation	5-17
smoothing	5-65
SNAP Group	5-92
SStart Group	5-92
standard event register	6-3
STARt Group	5-92
statistical processing count	5-74
status byte	6-2
status byte register	5-120
status function	5-93
STATus Group	5-93
status report	6-1
STOP Group	5-94
storage medium	5-41
STORe Group	5-95
stored to the internal memory	5-95
SYSTem Group	5-96

T

T/div	5-99
target trace of the zone	5-51
TCP/IP setting	3-6
time	5-97

time base	5-16, 5-99
TI梅base Group	5-99
timeout time	3-6
transit filter	5-94
trigger coupling	5-107, 5-108
trigger delay	5-106
TRIGger Group	5-100
trigger level	5-107, 5-108
trigger mode	5-106
trigger position	5-107
trigger slope	5-108
trigger source	5-108
TV trigger	5-109
type of cursor (T-Y display)	5-29

U

USB connector	2-4
USB interface connector	2-1
USB keyboard	5-98
user name	3-6
user verification function	3-3

V

V/div	5-21
vertical cursor (T-Y display)	5-29
vertical cursor (X-Y display)	5-31
vertical position	5-21
voltage sensitivity	5-21

W

waveform data	5-111
WAVeform Group	5-111
waveform parameter	5-73
waveform parameter determination	5-48
waveform zoom	5-117
window trigger	5-109

X

X-Y display	5-114
XY Group	5-114

Z

zone determination	5-53
ZOOM Group	5-116
zoom rate (search & zoom)	5-87
zoomed waveform	5-117

Command List

ACquire Group	
:ACquire?	5-16
:AVERage:COUNT	5-16
:AVERage:EWEight	5-16
:AVERage?	5-16
:CLOCK	5-16
:COUNT	5-16
:INTerleave	5-16
:MODE	5-16
:REPetitive	5-16
:RLENgth	5-16
ASETup Group	
:EXECute	5-17
:UNDO	5-17
CALibrate Group	
:CALibrate?	5-17
:DESKew:MODE	5-17
:DESKew:TARGeT	5-17
:DESKew:TIME	5-17
:DESKew?	5-17
:MODE	5-18
[:EXECute]	5-18
CHANnel Group	
:BWIDth	5-20
:CHANnel<x>?	5-20
:COUPling	5-20
:DISPlay	5-20
:LABel	5-20
:LSCale:AVALue	5-20
:LSCale:BVALue	5-20
:LSCale:MODE	5-20
:LSCale:UNIT	5-20
:LSCale?	5-20
:MODE	5-21
:OFFSet	5-21
:POSition	5-21
:PROBe	5-21
:VARIable	5-21
:VDIV	5-21
CLEar Group	
:CLEar	5-22
COMMunicate Group	
:COMMunicate?	5-23
:HEADer	5-23
:LOCKout	5-23
:OPSE	5-24
:OPSR?	5-24
:OVERlap	5-24
:REMOte	5-24
:STAus?	5-24
:VERBose	5-24
:WAIT	5-24
:WAIT?	5-24
CURSor Group	
:CURSor?	5-27
:TY:DEGRee:DX?	5-27
:TY:DEGRee:DY?	5-27
:TY:DEGRee:JUMP	5-27
:TY:DEGRee:POSition<x>	5-27
:TY:DEGRee:REFerence<x>	5-27
:TY:DEGRee:RVALue	5-27
:TY:DEGRee:TACe	5-28
:TY:DEGRee:X<x>?	5-28
:TY:DEGRee:Y<x>?	5-28
:TY:DEGRee?	5-27
:TY:HORIZontal:DY?	5-28
:TY:HORIZontal:POSition<x>	5-28

Index

:TY:HORizontal:TRACe	5-28
:TY:HORizontal:Y<x>?	5-28
:TY:HORizontal?	5-28
:TY:MARKer:DX<x>?	5-29
:TY:MARKer:DY<x>?	5-29
:TY:MARKer:M<x>:JUMP	5-29
:TY:MARKer:M<x>:POSition	5-29
:TY:MARKer:M<x>:TRACe	5-29
:TY:MARKer:M<x>?	5-29
:TY:MARKer:X<x>?	5-29
:TY:MARKer:Y<x>?	5-29
:TY:MARKer?	5-28
:TY:TYPE	5-29
:TY:VERTical:DX?	5-30
:TY:VERTical:DY?	5-30
:TY:VERTical:JUMP	5-30
:TY:VERTical:PERDt?	5-30
:TY:VERTical:POSition<x>	5-30
:TY:VERTical:TRACe	5-30
:TY:VERTical:X<x>?	5-30
:TY:VERTical:Y<x>?	5-30
:TY:VERTical?	5-29
:TY?	5-27
:XY:HORizontal:DY?	5-30
:XY:HORizontal:POSition<x>	5-31
:XY:HORizontal:TRACe	5-31
:XY:HORizontal:Y?	5-31
:XY:HORizontal?	5-30
:XY:MARKer:POSition	5-31
:XY:MARKer:T?	5-31
:XY:MARKer:TRACe	5-31
:XY:MARKer:X?	5-31
:XY:MARKer:Y?	5-31
:XY:MARKer?	5-31
:XY:TYPE	5-31
:XY:VERTical:DX?	5-31
:XY:VERTical:POSition<x>	5-31
:XY:VERTical:TRACe	5-32
:XY:VERTical:X<x>?	5-32
:XY:VERTical?	5-31
:XY?	5-30
Common Command Group	
*CAL?	5-118
*CLS	5-118
*ESE	5-118
*ESR?	5-119
*IDN?	5-119
*LRN?	5-119
*OPC	5-119
*OPC?	5-120
*OPT?	5-120
*PSC	5-120
*RST	5-120
*SRE	5-120
*STB?	5-120
*TST?	5-120
*WAI	5-120
DISPlay Group	
:ACCumulate:COLor	5-35
:ACCumulate:MODE	5-35
:ACCumulate:PERsistence	5-35
:ACCumulate?	5-35
:COLor	5-35
:DISPlay?	5-35
:FORMat	5-36
:GRATicule	5-36
:INTENsity:{CURSor MENU GRID SNAP WAVEform}	5-36
:INTENsity?	5-36
:INTERpolate	5-36
:MAPPING	5-36
:RGB:MENU:{BACK DIALog FOCUS FORE LINE SElect SHADow}	5-35
:RGB:MENU?	5-35
:RGB:OTHerS:{CURSor GRID MARKer SNAP ZONE<x>}	5-36
:RGB:OTHerS?	5-35
:RGB:WAVEform?	5-36
:RGB?	5-35
:SMAPPING:{CHANnel<x> MATH<x>}	5-37
:SMAPPING?	5-36
:SVALue	5-37
:TLABel	5-37
:TRANslucent	5-37
RGB:WAVEform:{CHANnel<x> BACK MATH<x>}	5-36
FILE Group	
:DELete:{ASCIi BINary BMP FLOat JPEG MEASure PNG POSTscript SETup SNAP TIFF}{:EXECute}	5-41
:DIRectry?	5-41
:FILE?	5-41
:FORMat:EXECute	5-41
:LOAD:{BINary SETup SNAP}:ABORt	5-41
:LOAD:{BINary SETup SNAP}{:EXECute}	5-41
:LOAD:SNAP:PLANE	5-42
:LOAD:SNAP?	5-41
:LOAD?	5-41
:SAVE:{ASCIi BINary FLOat MEASure SETup SNAP}:ABORt	5-42
:SAVE:{ASCIi BINary FLOat MEASure SETup SNAP}{:EXECute}	5-42
:SAVE:{ASCIi BINary FLOat}:HISTory	5-42
:SAVE:{ASCIi BINary FLOat}:RANGE	5-42
:SAVE:{ASCIi BINary FLOat}:TRACe	5-42
:SAVE:{ASCIi BINary FLOat}?	5-42
:SAVE:ANAMing	5-42
:SAVE:BINary:COMPReSSion	5-42
:SAVE:COMMENT	5-42
:SAVE:NAME	5-43
:SAVE?	5-42
:UNLoad:{BINary SNAP}?	5-43
:UNLoad:{BINary SNAP}{:EXECute}	5-43
:UNLoad:BINary:TRACe	5-43
:UNLoad:SNAP:PLANE	5-43
:UNLoad?	5-43
[:DIRectry]:CDIRectory	5-41
[:DIRectry]:DRIVE	5-41
[:DIRectry]:FILTer	5-41
[:DIRectry]:FREE?	5-41
[:DIRectry]:MDIRectory	5-41
[:DIRectry]:PATH?	5-41
GONogo Group	
:ABORt	5-47
:ACTion:BUZZer	5-47
:ACTion:HCOpy	5-47
:ACTion:IMAGe	5-47
:ACTion:MAIL:COUNT	5-47
:ACTion:MAIL:MODE	5-47
:ACTion:MAIL?	5-47
:ACTion:SAVE	5-47
:ACTion?	5-47
:COUNT?	5-48
:EXECute	5-48
:GONogo?	5-47
:LOGic	5-48
:MODE	5-48
:NGCount?	5-48
:PARAmeter:ITEM<x>:CAUSE?	5-48
:PARAmeter:ITEM<x>:CONDition	5-48
:PARAmeter:ITEM<x>:MODE	5-48

:PARAMeter:ITEM<x>:TRACe	5-48
:PARAMeter:ITEM<x>:TYPE:<Parameter>	5-49
:PARAMeter:ITEM<x>:TYPE?	5-48
:PARAMeter:ITEM<x>:VALue?	5-49
:PARAMeter:ITEM<x>?	5-48
:PARAMeter?	5-48
:SEQuence	5-49
:STOPcount	5-49
:TLINKage	5-49
:TRANge	5-49
:WAIT?	5-49
:ZONE:EDIT<x>:EXIT	5-50
:ZONE:EDIT<x>:PART	5-50
:ZONE:EDIT<x>:WHOLe	5-50
:ZONE:ZONE<x>:CAUSE?	5-50
:ZONE:ZONE<x>:CONDition	5-50
:ZONE:ZONE<x>:MODE	5-50
:ZONE:ZONE<x>:SEND	5-51
:ZONE:ZONE<x>:TRACe	5-51
:ZONE:ZONE<x>?	5-50
:ZONE?	5-49
HCOPY Group	
:ABORt	5-53
:COMMeNt	5-53
:DIRectioN	5-53
:EXECute	5-53
:EXTPrinter:PRINter?	5-53
:EXTPrinter:SELect	5-53
:EXTPrinter:TONE	5-54
:EXTPrinter:TYPE	5-54
:EXTPrinter?	5-53
:HCOpy?	5-53
:NETprint:TONE	5-54
:NETprint:TYPE	5-54
:NETprint?	5-54
:PRINter:MAG	5-54
:PRINter:RANGe	5-54
:PRINter:REPort	5-54
:PRINter:TLINKage	5-54
:PRINter:TYPE	5-54
:PRINter?	5-54
HISTory Group	
:ABORt	5-57
:DISPlay	5-57
:DMODE	5-57
:EXECute	5-57
:HISTory?	5-57
:PARAMeter:ITEM<x>:CONDition	5-57
:PARAMeter:ITEM<x>:SOURce	5-58
:PARAMeter:ITEM<x>:TYPE:<parameter>	5-58
:PARAMeter:ITEM<x>:VALue?	5-58
:PARAMeter:ITEM<x>?	5-57
:PARAMeter:LOGic	5-58
:PARAMeter:TLINKage	5-58
:PARAMeter:TRANge	5-58
:PARAMeter?	5-57
:RECOrd	5-58
:RECOrd? MINimum	5-58
:SMODE	5-58
:TIME?	5-59
:ZONE:EDIT<x>:CONDition	5-59
:ZONE:EDIT<x>:HORizontal	5-59
:ZONE:EDIT<x>:SOURce	5-59
:ZONE:EDIT<x>:VERTical	5-59
:ZONE:EDIT<x>?	5-59
:ZONE:LOGic	5-59
:ZONE?	5-59
IMAGe Group	
:ABORt	5-61
:COMMeNt	5-61
:COMPression	5-61
:EXECute	5-61
:FORMat	5-61
:IMAGe?	5-61
:SAVE:ANAMing	5-61
:SAVE:CDIRectory	5-61
:SAVE:DRIVE	5-61
:SAVE:NAME	5-61
:SAVE?	5-61
:SEND?	5-61
:TONE	5-61
INITialize Group	
:EXECute	5-62
:UNDO	5-62
MATH Group	
:BINary:{CHANnel<x> MATH1}	5-64
:BINary?	5-64
:DISPlay	5-64
:FFT:POINts	5-64
:FFT:SPOint	5-64
:FFT:WINDow	5-64
:FFT?	5-64
:INTegral:SPOint	5-64
:INTegral?	5-64
:LABel	5-65
:MATH<x>?	5-64
:OPERation	5-65
:SCALE:CENTer	5-65
:SCALE:MODE	5-65
:SCALE:SENSitivity	5-65
:SCALE?	5-65
:SMOothing	5-65
:UNIT	5-65
MEASure Group	
{CHANnel<x> MATH<x>}:<Parameter> ?	5-73
{CHANnel<x> MATH<x>}:<Parameter>:{MAXimum MEAN MINimum SDEVIation}?	5-74
{CHANnel<x> MATH<x>}:<Parameters>:COUNT?	5-74
{CHANnel<x> MATH<x>}:<Parameters>:STATe	5-74
{CHANnel<x> MATH<x>}:<Parameters>:VALue?	5-74
{CHANnel<x> MATH<x>}:ALL	5-71
{CHANnel<x> MATH<x>}:COPY	5-71
{CHANnel<x> MATH<x>}:DELay:MEASure:COUNT	5-71
{CHANnel<x> MATH<x>}:DELay:MEASure:SLOPe	5-71
{CHANnel<x> MATH<x>}:DELay:MEASure?	5-71
{CHANnel<x> MATH<x>}:DELay:REFerence:COUNT	5-72
{CHANnel<x> MATH<x>}:DELay:REFerence:SLOPe	5-72
{CHANnel<x> MATH<x>}:DELay:REFerence:SOURce	5-72
{CHANnel<x> MATH<x>}:DELay:REFerence:TRACe	5-72
{CHANnel<x> MATH<x>}:DELay:REFerence?	5-72
{CHANnel<x> MATH<x>}:DELay:STATe	5-72
{CHANnel<x> MATH<x>}:DELay?	5-71
{CHANnel<x> MATH<x>}:DPRoximal:MODE	5-73
{CHANnel<x> MATH<x>}:DPRoximal:PERCent	5-73
{CHANnel<x> MATH<x>}:DPRoximal:UNIT	5-73
{CHANnel<x> MATH<x>}:DPRoximal?	5-73
{CHANnel<x> MATH<x>}:METHod	5-73
{CHANnel<x> MATH<x>}?	5-71
:AMODE	5-70
:CONSt<x>	5-75
:CYCLE:ABORt	5-75
:CYCLE:EXECute	5-75

Index

:CYCLE:TRACe	5-75	:SEARCH?	5-86
:CYCLE?	5-75	:SElect	5-89
:HISTory:ABORt	5-75	:SElect? MAXimum	5-89
:HISTory:EXECute	5-75	:SPATtern:CLEar	5-89
:MEASure?	5-69	:SPATtern:CLOCK:HYSTeresis	5-89
:MODE	5-75	:SPATtern:CLOCK:LEVEl	5-89
:ONECycle	5-75	:SPATtern:CLOCK:SLOPe	5-89
:TLINKage<x>	5-75	:SPATtern:CLOCK:SOURce	5-89
:TRANge<x>	5-75	:SPATtern:CLOCK?	5-89
:USER<x>:{MAXimum MEAN MINimum SDEVIation}?	5-76	:SPATtern:INTErval	5-90
:USER<x>:AREA<y>:ITEM	5-76	:SPATtern:LEVEl	5-90
:USER<x>:AREA<y>:TRACe	5-76	:SPATtern:PATTern<x>	5-90
:USER<x>:AREA<y>?	5-76	:SPATtern:PSElect	5-90
:USER<x>:COUNT?	5-76	:SPATtern:SOURce	5-90
:USER<x>:OPERation	5-76	:SPATtern?	5-89
:USER<x>:STATe	5-76	:SPOint	5-90
:USER<x>:UNIT	5-76	:TWINdow	5-90
:USER<x>:VALue?	5-77	:TYPE	5-90
:USER<x>?	5-76	:WIDTh:HYSTeresis	5-91
:WAIT?	5-77	:WIDTh:LEVEl	5-91
PHASe Group		:WIDTh:POLarity	5-91
:CHANnel<x>	5-78	:WIDTh:SOURce	5-91
:MODE	5-78	:WIDTh:TIME<x>	5-91
:PHASe?	5-78	:WIDTh:TYPE	5-91
PRESet Group		:WIDTh?	5-90
:ALL:PROBe	5-80	SNAP Group	
:ALL:TYPE	5-80	:SNAP	5-92
:ALL:USERdefine:LEVEl	5-80	SStart Group	
:ALL:USERdefine:OFFSet	5-80	:SStart?	5-92
:ALL:USERdefine:VDIV	5-80	StARt Group	
:CHANnel<x>:PROBe	5-80	:StARt	5-92
:CHANnel<x>:TYPE	5-80	STATus Group	
:CHANnel<x>:USERdefine:LEVEl	5-80	:CONDition?	5-93
:CHANnel<x>:USERdefine:OFFSet	5-81	:EESe	5-93
:CHANnel<x>:USERdefine:VDIV	5-81	:EESR?	5-93
:CHANnel<x>:USERdefine?	5-80	:ERRor?	5-93
:CHANnel<x>?	5-80	:FILTer<x>	5-94
:EXECute	5-81	:QENable	5-94
:PRESet?	5-80	:QMESsage	5-94
:SElectch	5-81	:SPOLI?	5-94
RECall Group		:STATus?	5-93
:SEtup<x>:EXECute	5-82	StOP Group	
SEARCh Group		:StOP	5-94
:ABORt	5-86	StORe Group	
:ASCRoll:DIRection	5-86	:SEtup<x>:COMMEnt	5-95
:ASCRoll:SPEed	5-86	:SEtup<x>:DATE?	5-95
:ASCRoll?	5-86	:SEtup<x>:EXECute	5-95
:EDGE:COUNT	5-86	:SEtup<x>:LOCK	5-95
:EDGE:HYSTeresis	5-86	:SEtup<x>?	5-95
:EDGE:LEVEl	5-86	:StORe?	5-95
:EDGE:SLOPe	5-86	SYStem Group	
:EDGE:SOURce	5-87	:BATTery?	5-97
:EDGE?	5-86	:CLICk	5-97
:EXECute	5-87	:CLOCK:DATE	5-97
:MAG<x>	5-87	:CLOCK:MODE	5-97
:MLINKage	5-87	:CLOCK:SNTP:EXECute	5-97
:PLINKage	5-87	:CLOCK:SNTP:GMTTime	5-97
:POSition<x>	5-87	:CLOCK:SNTP?	5-97
:PPATtern:{CHANnel<x> MATH<x>}:HYSTeresis	5-87	:CLOCK:TIME	5-97
:PPATtern:{CHANnel<x> MATH<x>}:LEVEl	5-88	:CLOCK:TYPE	5-97
:PPATtern:{CHANnel<x> MATH<x>}:PATTern	5-88	:CLOCK?	5-97
:PPATtern:{CHANnel<x> MATH<x>}?	5-87	:LANGuage	5-97
:PPATtern:CLOCK:HYSTeresis	5-88	:LCD:AUTO:MODE	5-97
:PPATtern:CLOCK:LEVEl	5-88	:LCD:AUTO:TIME	5-98
:PPATtern:CLOCK:SLOPe	5-88	:LCD:AUTO?	5-97
:PPATtern:CLOCK:SOURce	5-88	:LCD:BRIghtness	5-98
:PPATtern:CLOCK?	5-88	:LCD:MODE	5-98
:PPATtern?	5-87	:LCD?	5-97
		:MLANGuage	5-98

:OCANcel	5-98	:WIDTH:TYPE	5-110
:OVERview	5-98	:WIDTH:WINDow	5-110
:SINformation	5-98	:WIDTH?	5-109
:SYSTem?	5-97	[:SIMPlE]:COUPling	5-107
:TGATe	5-98	[:SIMPlE]:HFRejection	5-107
:USBKeyboard	5-98	[:SIMPlE]:HYSTeresis	5-107
TIMebase Group		[:SIMPlE]:LEVel	5-107
:SOURce	5-99	[:SIMPlE]:PROBe	5-107
:SRATe?	5-99	[:SIMPlE]:RANGe	5-107
:TDIV	5-99	[:SIMPlE]:SLOPe	5-108
:TIMebase?	5-99	[:SIMPlE]?	5-107
TRIGger Group		WAVeform Group	
:ABN:COUNT	5-104	:BITS?	5-111
:ABN?	5-104	:BYTeorder	5-112
:ACTion:ACQCount	5-104	:DATaselect	5-112
:ACTion:BUZZer	5-104	:END	5-112
:ACTion:HCOPy	5-104	:FORMat	5-112
:ACTion:IMAGe	5-104	:LENGth?	5-112
:ACTion:MAIL:COUNT	5-105	:OFFSet?	5-112
:ACTion:MAIL:MODE	5-105	:RANGe?	5-112
:ACTion:MAIL?	5-104	:RECOrd	5-112
:ACTion:SAVE	5-105	:RECOrd? MINimum	5-112
:ACTion:STARt	5-105	:SEND?	5-113
:ACTion:STOP	5-105	:SIGN?	5-113
:ACTion?	5-104	:SRATe?	5-113
:ADB:DELay	5-105	:STARt	5-113
:ADB?	5-105	:TRACe	5-113
:ATRigger:CHANnel<x>	5-105	:TRIGger?	5-113
:ATRigger:CONDition	5-105	:TYPE?	5-113
:ATRigger?	5-105	:WAVeform?	5-111
:BTRigger:CHANnel<x>	5-105	XY Group	
:BTRigger:CONDition	5-105	:DISPlay	5-114
:BTRigger?	5-105	:MODE	5-114
:DELay	5-106	:TLINKage	5-114
:HOLDoff:TIME	5-106	:TRANge	5-115
:HOLDoff?	5-106	:XAXis	5-115
:MODE	5-106	:XTRace	5-115
:OR:CHANnel<x>	5-106	:XY<x>?	5-114
:OR:WINDow	5-106	:YTRace	5-115
:OR?	5-106	ZOOM Group	
:PATTern:CHANnel<x>	5-106	:ALLocation:{CHANnel<x> MATH<x>}	5-117
:PATTern:CLOCK:SLOPe	5-106	:ALLocation:ALL	5-117
:PATTern:CLOCK:SOURce	5-106	:ALLocation?	5-117
:PATTern:CLOCK?	5-106	:FITMeasure	5-117
:PATTern:CONDition	5-107	:FORMat	5-117
:PATTern?	5-106	:MAG<x>	5-117
:POSition	5-107	:MLINKage	5-117
:SCOUnt	5-107	:MODE	5-117
:SIMPlE:SOURce	5-108	:PLINKage	5-117
:SOURce:CHANnel<x>:COUPling	5-108	:POSition<x>	5-117
:SOURce:CHANnel<x>:HFRejection	5-108	:ZOOM?	5-117
:SOURce:CHANnel<x>:HYSTeresis	5-108		
:SOURce:CHANnel<x>:LEVel	5-108		
:SOURce:CHANnel<x>:WIDTH	5-109		
:SOURce:CHANnel<x>?	5-108		
:SOURce?	5-108		
:TRIGger?	5-104		
:TV:FIELD	5-109		
:TV:FRAMe	5-109		
:TV:LEVel	5-109		
:TV:LINE	5-109		
:TV:POLarity	5-109		
:TV:TYPE	5-109		
:TV?	5-109		
:TYPE	5-109		
:WIDTH:CHANnel<x>	5-109		
:WIDTH:CONDition	5-110		
:WIDTH:TIME<x>	5-110		
:WIDTH:TLINKage	5-110		