

**Power Electronics  
Design:  
A Practitioner's Guide**

---

---



# Power Electronics Design: A Practitioner's Guide

---

---

Keith H. Sueker



AMSTERDAM • BOSTON • HEIDELBERG • LONDON  
NEW YORK • OXFORD • PARIS • SAN DIEGO  
SAN FRANCISCO • SINGAPORE • SYDNEY • TOKYO

Newnes is an imprint of Elsevier



Newnes is an imprint of Elsevier  
30 Corporate Drive, Suite 400, Burlington, MA 01803, USA  
Linacre House, Jordan Hill, Oxford OX2 8DP, UK

Copyright © 2005, SciTech Publishing Inc.  
911 Paverstone Dr., Ste. B  
Raleigh, NC 27615  
www.scitechpub.com

All rights reserved.

No part of this publication may be reproduced, stored in a retrieval system, or transmitted in any form or by any means, electronic, mechanical, photocopying, recording, or otherwise, without the prior written permission of the publisher.

Permissions may be sought directly from Elsevier's Science & Technology Rights Department in Oxford, UK: phone: (+44) 1865 843830, fax: (+44) 1865 853333, e-mail: [permissions@elsevier.com.uk](mailto:permissions@elsevier.com.uk). You may also complete your request online via the Elsevier homepage (<http://www.elsevier.com>), by selecting "Customer Support" and then "Obtaining Permissions."

Tables 14.4 and 14.5 reprinted with permission from IEEE Std. 519-1992—Recommended Practices and Requirements for Harmonic Control in Electrical Power Systems, Copyright 1996<sup>©</sup>, by IEEE. The IEEE disclaims any responsibility or liability resulting from the placement and use in the described manner.



Recognizing the importance of preserving what has been written, Elsevier prints its books on acid-free paper whenever possible.

#### **Library of Congress Cataloging-in-Publication Data**

Sueker, Keith H.  
Power electronics design : a practitioner's guide / by Keith H. Sueker.—1st ed.  
p. cm.  
Includes bibliographical references and index.  
ISBN 0-7506-7927-1 (hardcover : alk. paper) 1. Power electronics—Design and construction. I. Title.  
TK7881.15.S84 2005  
621.31'7--dc22  
2005013673

#### **British Library Cataloguing-in-Publication Data**

A catalogue record for this book is available from the British Library.

ISBN: 0-7506-7946-8

For information on all Newnes publications  
visit our website at [www.books.elsevier.com](http://www.books.elsevier.com)

05 06 07 08 09 10 10 9 8 7 6 5 4 3 2 1

Printed in the United States of America

Working together to grow  
libraries in developing countries

[www.elsevier.com](http://www.elsevier.com) | [www.bookaid.org](http://www.bookaid.org) | [www.sabre.org](http://www.sabre.org)

ELSEVIER

BOOK AID  
International

Sabre Foundation

# Contents

---

---

<b>List of Figures</b> .....	<b>xi</b>
<b>List of Tables</b> .....	<b>xvii</b>
<b>Preface</b> .....	<b>xix</b>
<b>Chapter 1 Electric Power</b> .....	<b>1</b>
1.1 AC versus DC.....	1
1.2 Pivotal Inventions.....	3
1.3 Generation.....	4
1.4 Electric Traction.....	5
1.5 Electric Utilities.....	6
1.6 In-Plant Distribution.....	11
1.7 Emergency Power.....	12
<b>Chapter 2 Power Apparatus</b> .....	<b>15</b>
2.1 Switchgear.....	15
2.2 Surge Suppression.....	19
2.3 Conductors.....	21
2.4 Capacitors.....	25
2.5 Resistors.....	28
2.6 Fuses.....	31
2.7 Supply Voltages.....	32

2.8	Enclosures . . . . .	32
2.9	Hipot, Corona, and BIL. . . . .	33
2.10	Spacings . . . . .	34
2.11	Metal Oxide Varistors. . . . .	35
2.12	Protective Relays. . . . .	37
<b>Chapter 3 Analytical Tools. . . . .</b>		<b>39</b>
3.1	Symmetrical Components . . . . .	39
3.2	Per Unit Constants. . . . .	41
3.3	Circuit Simulation . . . . .	43
3.4	Circuit Simulation Notes. . . . .	45
3.5	Simulation Software . . . . .	47
<b>Chapter 4 Feedback Control Systems. . . . .</b>		<b>49</b>
4.1	Basics . . . . .	49
4.2	Amplitude Responses . . . . .	50
4.3	Phase Responses . . . . .	53
4.4	PID Regulators . . . . .	54
4.5	Nested Control Loops . . . . .	56
<b>Chapter 5 Transients . . . . .</b>		<b>57</b>
5.1	Line Disturbances . . . . .	57
5.2	Circuit Transients . . . . .	58
5.3	Electromagnetic Interference . . . . .	61
<b>Chapter 6 Traveling Waves . . . . .</b>		<b>65</b>
6.1	Basics . . . . .	65
6.2	Transient Effects . . . . .	68
6.3	Mitigating Measures . . . . .	71
<b>Chapter 7 Transformers and Reactors . . . . .</b>		<b>73</b>
7.1	Transformer Basics . . . . .	74
7.2	Construction . . . . .	78
7.3	Insulation Systems. . . . .	82
7.4	Basic Insulation Level. . . . .	84
7.5	Eddy Current Effects. . . . .	85
7.6	Interphase Transformers . . . . .	89
7.7	Transformer Connections . . . . .	90
7.8	Reactors. . . . .	93

7.9	Units . . . . .	97
7.10	Cooling . . . . .	97
7.11	Instrument Transformers. . . . .	98
<b>Chapter 8 Rotating Machines . . . . .</b>		<b>101</b>
8.1	Direct Current Machines. . . . .	101
8.2	Synchronous Machines. . . . .	103
8.3	Induction (Asynchronous) Machines . . . . .	107
8.4	NEMA Designs. . . . .	110
8.5	Frame Types . . . . .	111
8.6	Linear Motors . . . . .	112
<b>Chapter 9 Rectifiers and Converters. . . . .</b>		<b>115</b>
9.1	Early Rectifiers . . . . .	115
9.2	Mercury Vapor Rectifiers . . . . .	116
9.3	Silicon Diodes—The Semiconductor Age . . . . .	117
9.4	Rectifier Circuits—Single-Phase . . . . .	118
9.5	Rectifier Circuits—Multiphase. . . . .	120
9.6	Commutation. . . . .	123
<b>Chapter 10 Phase Control . . . . .</b>		<b>125</b>
10.1	The SCR . . . . .	126
10.2	Forward Drop . . . . .	131
10.3	SCR Circuits—AC Switches . . . . .	131
10.4	SCR Motor Starters. . . . .	135
10.5	SCR Converters . . . . .	137
10.6	Inversion . . . . .	139
10.7	Gate Drive Circuits. . . . .	142
10.8	Power to the Gates . . . . .	145
10.9	SCR Autotapchangers. . . . .	145
10.10	SCR DC Motor Drives . . . . .	148
10.11	SCR AC Motor Drives . . . . .	148
10.12	Cycloconverters . . . . .	150
<b>Chapter 11 Series and Parallel Operation . . . . .</b>		<b>153</b>
11.1	Voltage Sharing . . . . .	153
11.2	Current Sharing. . . . .	158
11.3	Forced Sharing . . . . .	160

<b>Chapter 12 Pulsed Converters . . . . .</b>	<b>163</b>
12.1 Protective Devices . . . . .	163
12.2 Transformers . . . . .	164
12.3 SCRs . . . . .	166
<b>Chapter 13 Switchmode Systems . . . . .</b>	<b>169</b>
13.1 Pulse Width Modulation . . . . .	169
13.2 Choppers . . . . .	173
13.3 Boost Converters . . . . .	174
13.4 The “H” Bridge . . . . .	175
13.5 High-Frequency Operation . . . . .	178
13.6 Harmonic Injection . . . . .	179
13.7 Series Bridges . . . . .	180
<b>Chapter 14 Power Factor and Harmonics . . . . .</b>	<b>181</b>
14.1 Power Factor . . . . .	181
14.2 Harmonics . . . . .	184
14.3 Fourier Transforms . . . . .	189
14.4 Interactions with the Utility . . . . .	194
14.5 Telephone Influence Factor . . . . .	199
14.6 Distortion Limits . . . . .	201
14.7 Zero-Switching . . . . .	202
<b>Chapter 15 Thermal Considerations . . . . .</b>	<b>203</b>
15.1 Heat and Heat Transfer . . . . .	203
15.2 Air Cooling . . . . .	205
15.3 Water Cooling . . . . .	206
15.4 Device Cooling . . . . .	208
15.5 Semiconductor Mounting . . . . .	213
<b>Chapter 16 Power Electronics Applications . . . . .</b>	<b>215</b>
16.1 Motor Drives and SCR Starters . . . . .	215
16.2 Glass Industry . . . . .	217
16.3 Foundry Operations . . . . .	218
16.4 Plasma Arcs and Arc Furnaces . . . . .	219
16.5 Electrochemical Supplies . . . . .	219
16.6 Cycloconverters . . . . .	220
16.7 Extremely Low-Frequency Communications . . . . .	221



16.8	Superconducting Magnet Energy Storage	222
16.9	600-kW Opamp	223
16.10	Ozone Generators	223
16.11	Semiconductor Silicon	224
16.12	VAR Compensators	224
16.13	Induction Furnace Switch	225
16.14	Tokamaks	226
16.15	Multi-tap Switching	227
<b>Appendix A Converter Equations</b>		<b>229</b>
<b>Appendix B Lifting Forces</b>		<b>231</b>
<b>Appendix C Commutation Notches and THD<sub>v</sub></b>		<b>233</b>
<b>Appendix D Capacitor Ratings</b>		<b>235</b>
<b>Appendix E Rogowski Coils</b>		<b>237</b>
<b>Appendix F Foreign Technical Words</b>		<b>239</b>
<b>Appendix G Aqueous Glycol Solutions</b>		<b>241</b>
<b>Appendix H Harmonic Cancellation with Phase Shifting</b>		<b>243</b>
<b>Appendix I Neutral Currents with Nonsinusoidal Loads</b>		<b>245</b>
<b>Index</b>		<b>247</b>



## List of Figures

---

---

Figure 1.1	Generation systems. ....	3
Figure 1.2	Typical section of a utility. ....	7
Figure 2.1	Power electronics symbols.....	16
Figure 2.2	Typical wire labeling. ....	22
Figure 2.3	Stress cone termination for shielded cable.....	24
Figure 2.4	Capacitor construction. ....	27
Figure 2.5	Power resistor types. ....	30
Figure 2.6	Simple corona tester.....	34
Figure 2.7	480-V, 60-mm MOV characteristic. ....	36
Figure 3.1	Symmetrical components.....	41
Figure 3.2	Arc heater circuit.....	44
Figure 3.3	Circuit voltage and current waveforms.....	44
Figure 4.1	Basic feedback system. ....	49
Figure 4.2	R/C frequency response. ....	51
Figure 4.3	Frequency responses of various networks. ....	51
Figure 4.4	Composite response. ....	52
Figure 4.5	Frequency responses, $F(s)$ , and corresponding time responses, $f(t)$ .....	52
Figure 4.6	Phase responses of an R/C low-pass filter. ....	54
Figure 4.7	Phase lag of a 1.4-ms transport lag. ....	55
Figure 4.8	PID regulator.....	55

Figure 4.9	Nested control loops. ....	56
Figure 5.1	Signal wire routing.....	59
Figure 5.2	R/C notch reduction filter. ....	60
Figure 5.3	Multiplier input filtering. ....	61
Figure 5.4	T-section filter.....	62
Figure 5.5	Shunt wiring.....	62
Figure 5.6	Preferred shunt construction. ....	63
Figure 6.1	Transmission line difference equations. ....	67
Figure 6.2	Transmission line parameters. ....	67
Figure 6.3	Transmission line reflections—open load. ....	69
Figure 6.4	Front-of-wave shaping.....	70
Figure 6.5	Overshoot as a function of rise time. ....	71
Figure 7.1	Coupled coils. ....	74
Figure 7.2	Ideal transformer.....	75
Figure 7.3	Typical transformer representation. ....	76
Figure 7.4	Transformer regulation phasor diagram.....	77
Figure 7.5	Three-winding transformer. ....	78
Figure 7.6	Transformer cross sections. ....	79
Figure 7.7	Split bobbin transformer. ....	83
Figure 7.8	Surge voltage distribution in a transformer winding. ....	85
Figure 7.9	Transposition to reduce eddy currents.....	86
Figure 7.10	Eddy currents in lamination iron.....	86
Figure 7.11	Eddy current losses in windings. ....	88
Figure 7.12	Eddy current heating in shield materials.....	89
Figure 7.13	Two- and three-leg interphase transformer cores. ....	90
Figure 7.14	Autotransformer connections.....	91
Figure 7.15	Transformer primary taps. ....	91
Figure 7.16	Paralleled transformers. ....	92
Figure 7.17	Phase-shifted secondaries, 24-pulse.....	93
Figure 7.18	Basic equations for an inductive circuit.....	94
Figure 7.19	Inductance of a single-layer solenoid. ....	94
Figure 7.20	Inductance of a short, fat, multilayer coil. ....	95
Figure 7.21	Inductance of a thin, flat, spiral coil. ....	95
Figure 7.22	Inductance of a single-layer toroidal coil.....	95

Figure 7.23	Elementary iron-core conductor. ....	96
Figure 7.24	Three-phase inductance measurement. ....	96
Figure 7.25	Skirting to improve transformer cooling.....	98
Figure 8.1	DC motor characteristics.....	102
Figure 8.2	DC motor control. ....	103
Figure 8.3	Generator phasor diagram. ....	104
Figure 8.4	Generator and motor torque angles.....	106
Figure 8.5	Induction motor equivalent circuit.....	108
Figure 8.6	Induction motor torque and current. ....	108
Figure 8.7	Supersynchronous operation.....	109
Figure 8.8	NEMA design torque curves.....	111
Figure 8.9	Induction motor frame types. ....	111
Figure 8.10	Elementary rail gun.....	113
Figure 9.1	Half-wave rectifier characteristics. ....	118
Figure 9.2	Full-wave, center-tapped rectifier circuit and waveforms.....	120
Figure 9.3	Single-phase bridge (double-way) rectifier and waveforms.....	121
Figure 9.4	Three-phase double-wye interphase and bridge rectifier circuit.....	121
Figure 9.5	Commutation in a three-phase bridge rectifier. ...	123
Figure 10.1	SCR characteristics. ....	126
Figure 10.2	Typical SCR gate drive.....	127
Figure 10.3	SCR recovery characteristics. ....	128
Figure 10.4	Equivalent SCR recovery circuit and difference equations.....	129
Figure 10.5	Single-phase SCR AC switch. ....	132
Figure 10.6	SCR single-phase AC switch waveforms. ....	132
Figure 10.7	Three-phase SCR AC switches.....	133
Figure 10.8	Three-phase AC switch, 60° phaseback, 0.8 pf lagging load. ....	134
Figure 10.9	Three-phase AC switch, 120° phaseback, 0.8 pf lagging load. ....	134
Figure 10.10	Starting characteristic of induction motor with SCR starter.....	136
Figure 10.11	Speed profile with SCR starter. ....	137

Figure 10.12	SCR three-phase bridge converter. ....	138
Figure 10.13	Converter L-N voltages and line currents (inductive load). ....	139
Figure 10.14	Converter bus voltages. ....	139
Figure 10.15	Converter line-to-line voltage. ....	140
Figure 10.16	Converter DC output voltage. ....	140
Figure 10.17	Converter DC inversion at 150° phaseback. ....	141
Figure 10.18	Cosine intercept SCR gate drive. ....	143
Figure 10.19	SCR autotapchanger. ....	146
Figure 10.20	Displacement power factors. ....	147
Figure 10.21	Reversing, regenerative SCR DC motor drive. ....	148
Figure 10.22	SCR current source inverter AC drive. ....	149
Figure 10.23	SCR load-commutated inverter AC drive. ....	150
Figure 11.1	High-level gate drive. ....	154
Figure 11.2	Series SCR gate drive arrangements. ....	155
Figure 11.3	Anode-cathode derived gating. ....	156
Figure 11.4	Series SCR recovery characteristics. ....	156
Figure 11.5	Sharing network for series SCRs. ....	157
Figure 11.6	Bus layouts. ....	158
Figure 11.7	Self and mutual inductances. ....	159
Figure 11.8	Sharing reactors. ....	160
Figure 13.1	Basic pulse width modulation. ....	170
Figure 13.2	IGBT schematic and characteristics. ....	172
Figure 13.3	Chopper circuit and waveforms. ....	173
Figure 13.4	Ripple in paralleled choppers. ....	174
Figure 13.5	Chopper at 50% duty cycle. ....	175
Figure 13.6	IGBT boost converter. ....	175
Figure 13.7	“H” bridge. ....	176
Figure 13.8	PWM sine wave switching. ....	176
Figure 13.9	IGBT motor drive. ....	177
Figure 13.10	Chopper-controlled 30-kHz inverter. ....	178
Figure 13.11	Harmonic injection. ....	179
Figure 13.12	2400-V, 18-pulse series bridges. ....	180
Figure 14.1	Demand multiplier. ....	182
Figure 14.2	Power factor correction. ....	183
Figure 14.3	Fundamental with third harmonic. ....	186

Figure 14.4	SCR DC motor drive waveforms.....	187
Figure 14.5	SCR DC motor drive characteristics.....	188
Figure 14.6	Transforms in the complex plane.....	189
Figure 14.7	Transforms of pulses.....	189
Figure 14.8	Fourier transforms.....	190
Figure 14.9	Fourier transform for a symmetrical waveform. ....	190
Figure 14.10	Duty cycle rms value. ....	191
Figure 14.11	Six-pulse and 12-pulse harmonic spectra. ....	194
Figure 14.12	Harmonic resonance.....	195
Figure 14.13	Harmonic trap results.....	197
Figure 14.14	High-pass filters.....	198
Figure 14.15	Current and voltage distortion. ....	199
Figure 15.1	Fan delivery curves.....	206
Figure 15.2	Basic water cooling system.....	207
Figure 15.3	Transient thermal impedance curves. ....	211
Figure 15.4	Thermal network elements.....	212
Figure 15.5	Composite thermal network.....	213
Figure 15.6	SCR transient junction temperature rise. ....	213
Figure 16.1	Rod furnace autotapchanger supply.....	218
Figure 16.2	Typical electrochemical supply. ....	220
Figure 16.3	Three-phase cycloconverter.....	221
Figure 16.4	ELF transmitter. ....	222
Figure 16.5	600-kW Opamp.....	223
Figure 16.6	VAR compensator and control range.....	225
Figure 16.7	Solid-state contactor.....	226
Figure 16.8	Autotapchanger performance.....	227
Figure 16.9	Wide-range, zero-switched tap changer.....	228
Figure A.1	Single line diagram. ....	229
Figure B.1	Lifting forces and moments. ....	232
Figure C.1	Voltage distortion waveform. ....	233
Figure E.1	Rogowski coil construction.....	237
Figure G.1	Properties of ethylene and propylene glycol aqueous mixtures. ....	242





## List of Tables

---

---

Table 2.1	Switchgear Electrical Clearance Standards .....	35
Table 7.1	Transformer Characteristics.....	81
Table 7.2	Insulation Classes.....	82
Table 7.3	Air-Core/Iron-Core Inductor Comparisons.....	93
Table 7.4	Self and Mutual Inductances.....	95
Table 7.5	Magnetic Units.....	97
Table 10.1	Converter Equations.....	142
Table 14.1	Energy and Demand.....	182
Table 14.2	Equal Tempered Chromatic Scale .....	185
Table 14.3	Square Wave RMS Synthesis .....	192
Table 14.4	Single-Frequency TIF Values, IEEE 519 .....	200
Table 14.5	Current Distortion Limits for General Distribution Systems, IEEE 519 (120 through 69,000 V) .....	201
Table 14.6	Zero-Switching Spectra .....	202
Table 15.1	Thermal Constants .....	204
Table 15.2	Radiation Emissivities of Common Materials .....	205
Table F.1	Foreign Technical Words.....	239



## Preface

---

---

I have presented numerous courses in the form of noontime tutorials during my career with Robicon Corporation. These covered such essential subjects as transformers, transmission lines, heat transfer, transients, and semiconductors, to name but a few. The attendees were design engineers, sales engineers, technicians, and drafters. The tutorials were designed to present an overview of the power electronics field as well as design information for the engineers. They were very well received and appreciated. The material was useful to design engineers, but the technicians, drafters, and sales engineers appreciated the fact that I did not talk over their heads. I have also given tutorials to national meetings of the IEEE Industrial Applications Society as well as local presentations. This book represents a consolidation and organization of this material.

In this book, I have defined power electronics as the application of high-power semiconductor technology to large motor drives, power supplies, power conversion equipment, electric utility auxiliaries, and a host of other applications. It provides an overview of material no longer taught in most college electrical engineering curricula, and it contains a wealth of practical design information. It is also intended as a reference book covering design considerations that are not obvi-

ous but are better not learned the hard way. It presents an overview of the ancillary apparatus associated with power electronics as well as examples of potential pitfalls in the design process. The book approaches these matters in a simple, directed fashion with a minimum reliance on calculus. I have tried to put the overall design process into perspective as regards the primary electronic components and the many associated components that are required for a system.

My intended audience is design engineers, design drafters, and technicians now working in the power electronics industry. Students studying in two- and four-year electrical engineering and engineering technology programs, advanced students seeking a ready reference, and engineers working in other industries but with a need to know some essential aspects of power electronics will all find the book both understandable and useful. Readers of this book will most appreciate its down-to-earth approach, freedom from jargon and esoteric or non-essential information, the many simple illustrations used to clarify discussion points, and the vivid examples of costly design goofs.

When I was in graduate school, I was given a copy of *The Westinghouse Electrical Transmission and Distribution Reference Manual*. This book covered both theory and practice of the many aspects of the generation, transmission, and distribution of electric power. For me and thousands of engineers, it has been an invaluable reference book for all the years of my work in design. I hope to serve a similar function with this book on power electronics.

## **Acknowledgments**

I have attempted to write about the things I worked with during my 50 years in industry. Part were spent with Westinghouse in magnetic amplifiers and semiconductors and the last 30 with Robicon Corporation, now ASI Robicon. I had the privilege of working with some very talented engineers, and this book profits from their experiences as well as my own. As Engineering Manager of the Power Systems

group at Robicon, I had the best job in the world. My charge was simply to make whatever would work and result in a profit for the company. The understanding was that it would be at least loosely associated with power semiconductors, although I drifted into a line of medium-voltage, passive harmonic filters. Yes, we made money on them. The other aspect of my job was to mentor and work with some very talented young engineers. Their enthusiasm and hard work actually made me look good. My thanks to Junior, Ken, Pete, Bob, Frank, Geoff, Frank, Joe, Mark, Joe, Gene, and John. I also owe a debt of gratitude for the professional associations with Bob, Harry, Dick, and Pete. I gratefully acknowledge the personnel at SciTech Publishing, who helped develop the book, and J. K. Eckert & Co., who performed the editing and layout.

Lastly, I apologize for any errors and omissions and hope the book will prove useful in spite of them.

*Keith H. Sueker, PE*  
Consulting Engineer  
Pittsburgh, PA



## Chapter 1

---

---

# Electric Power

Relative to the digital age, the electric utility industry may seem old hat. But power electronics and the power industry have a growing symbiotic relationship. Nearly all power electronics systems draw power from the grid, and utility companies benefit from the application of power electronics to motor drives and to converters used for high-voltage DC transmission lines. The two fields are very much in a state of constant development of new systems and applications. For that reason, a short review of the history and the present state of the electric utility industry is appropriate for consideration by the power electronics engineer.

### 1.1. AC versus DC

*Take warning! Alternating currents are dangerous. They are fit only for powering the electric chair. The only similarity between an a-c and a d-c lighting system is that they both start from the same coal pile.*

And thus did Thomas Edison try to discourage the growing use of alternating-current electric power that was competing with his DC

systems. Edison had pioneered the first true central generating station at Pearl Street, in New York City, with DC. It had the ability to take generators on and off line and had a battery supply for periods of low demand. Distribution was at a few hundred volts, and the area served was confined because of the voltage drop in conductors of a reasonable size. The use of DC at relatively low voltages became a factor that limited the geographic growth of the electric utilities, but DC was well suited to local generation, and the use of electric power grew rapidly. Direct current motors gradually replaced steam engines for power in many industries. An individual machine could be driven by its own motor instead of having to rely on belting to a line shaft.

Low-speed reciprocating steam engines were the typical prime movers for the early generators, many being double-expansion designs in which a high-pressure cylinder exhausted steam to a low-pressure cylinder to improve efficiency. The double-expansion Corliss engines installed in 1903 for the IRT subway in New York developed 7500 hp at 75 rpm. Generators were driven at a speed higher than the engine by means of pulleys with rope or leather belts. Storage batteries usually provided excitation for the generators and were themselves charged from a small generator. DC machines could be paralleled simply by matching the voltage of the incoming machine to the bus voltage and then switching it in. Load sharing was adjusted by field control.

Alternating-current generators had been built for some years, but further use of AC power had been limited by the lack of a suitable AC motor. Low-frequency AC could be used on commutator motors that were basically DC machines, but attempts to operate them on the higher AC frequencies required to minimize lamp flicker were not successful. Furthermore, early AC generators could be paralleled only with difficulty, so each generator had to be connected to an assigned load and be on line at all times. Battery backup or battery supply at light load could not be used. Figure 1.1 shows the difference. Finally, generation and utilization voltages were similar to those with DC, so AC offered no advantage in this regard.



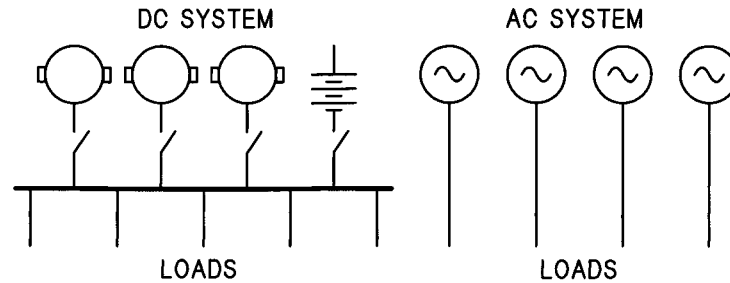

FIGURE 1.1 Generation systems.

## 1.2. Pivotal Inventions

Two key inventions then tipped the scales toward AC and initiated Edison's famous statement that opens this chapter. The first of these was the transformer. George Westinghouse acquired the patent rights from Gaulard and Gibbs for practical transformers. They allowed AC power to be transmitted at high voltages, then transformed to serve low-voltage loads. Power could now be transmitted with low losses yet be utilized at safe voltages, and this meant power could be generated at locations remote from the load. Hydroelectric generation could supply industries and households far from the dam. An early installation of AC generation and distribution was made by William Stanley, a Westinghouse expert, in Great Barrington, MA, in 1886. Distribution was at 500 V, and the Siemens generator, imported from London, supplied two transformers connected to some 200 lamps throughout the town.

The second invention was that of the induction motor, the result of research by a brilliant young engineer, Nikola Tesla, employed by Westinghouse. The first designs were for two-phase power, although three-phase designs soon followed. Three-phase transmission was preferred, because it minimized the amount of copper required to transmit a given amount of power. The simple, rugged induction motor was quickly put into production and was the key to utilizing AC

power by industry. The induction motor required no elaborate starting means, it was low in cost, and it offered important advantages in unfavorable environments. Together, the transformer and induction motor were responsible for the rapid growth of AC power.

The superiority of AC power was proven when Westinghouse lighted the Columbian Exposition at Chicago in 1893 with a two-phase system and literally turned night into day. Edison held the patents on the glass sealed incandescent lamp, so Westinghouse devised a stopper lamp design utilizing sealing wax. It was not a commercially successful design, but it did the job. The dazzling display was a source of awe for the visitors, many of whom had never seen an electric light.

A second major advance in AC generation and transmission was an installation at Niagara Falls. The power potential of the falls had been recognized for many years, and various schemes had been proposed for using compressed air and mechanical methods to harness the power. A final study resulted in the installation by Westinghouse in 1895 of AC generators using a 25-Hz, two-phase system that incorporated transformers and transmission lines to serve a number of factories. The 25-Hz frequency was chosen despite the growing popularity of 60 Hz, because it was recognized that a number of the process industries would require large amounts of DC power, and the rotary converters then used could not function on 60 Hz. Frequencies of 30, 40, 50, and 133 Hz were also in use in the 1890s, and 50 Hz persisted until mid century on the Southern California Edison System. A number of utilities also provided 25-Hz power late into the last century.

### 1.3. Generation

Slow-speed reciprocating steam engines kept growing in size to keep up with the demand for power until they topped out at around the cited 7500 hp. Some high-speed steam engines were used in England, but there was usually an order of magnitude difference between the preferred speeds for the engine and for the generator. The huge steam engines in use around the beginning of the twentieth century would

shake the ground and were disturbing to the local inhabitants. A steam turbine, directly connected to the generator, was the solution to this problem. A number of small turbines had been built on an experimental basis, but the 1901 installation of a 2000-kW, 1200-rpm, 60-Hz turbine generator set in Hartford, CT, set the stage for a rapid switch to turbines for future generation from steam. Ultimately, steam turbine generators were built at power levels over 1500 MW.

Hydroelectric generation also continued to grow in size. The Hoover Dam generators were installed with an 87 MVA rating each, but some were later rewound for 114 MVA. The huge generators for the Grand Coulee Third Powerhouse are rated 700 MW each, and the total Coulee generation is 6480 MW. These large concentrations of generation have made economies of scale possible, which have reduced generation costs and brought large-scale aluminum reduction plants and other power intensive industries to many remote locations.

#### **1.4. Electric Traction**

Siemens, in Germany, developed a DC motor suitable for use in powering trams. Electric power not only replaced the horses then in use on surface lines but made possible the development of vast subway systems. Because these systems served a large metropolitan area, the usual problem of DC distribution developed. The problem was not as acute as with residential use, because traction systems could use the relatively higher voltage of 600 V, and the earliest traction systems utilized DC generation and distribution. Around the turn of the century, however, the trend was to AC generation and high-voltage distribution with conversion to DC using rotary converters at local substations. These fed the trolley wires on surface lines or the third rails on subways and elevateds at 600 Vdc. In 1903, the Interborough Rapid Transit Company, in New York, adopted a system that used 11,000-V, 25-Hz, three-phase power for distribution and a 600-Vdc

third rail pickup for the cars of the new subway. Interestingly, the directors had decided in favor of reciprocating steam engines over turbines for generation, although they used several small turbine sets for lighting and excitation.

The use of electric power for transit also made possible interurban trolley lines, and by the early years of the last century, vast networks of trolley systems were extended to serve many small communities at lower cost than the steam trains could achieve. Again, higher-voltage AC generation and distribution were coupled with rotary converters to supply DC to the trolley wires. Interurban transit lines lasted until the development of good roads and reliable automobiles. Most were gone by mid century.

There were also a number of installations of electric motors to provide power for main-line traction. The New York New Haven and Hartford Railroad used 11,000-V, 25-Hz, three-phase power for transmission and single-phase power to supply the catenary. Transformers on the locomotives powered the traction motors in a parallel connection at 250 Vac. The motors were then switched in series to operate on a 600 Vdc third-rail so the trains could continue into Manhattan underground. The same distribution is in use today by Amtrak on the Northeast Corridor with the catenary supplied at 25 Hz by solid-state cycloconverters powered from the 60-Hz utility system. Several pioneering electric railroads in the USA used 3000 Vdc on the catenary, and three-phase 25-Hz AC systems were also used. Nearly every imaginable configuration of AC and DC power, including 16-2/3 Hz, was used for traction somewhere in the world. Except for commuter lines and special installations, most of the electric locomotives have been replaced by diesel electrics that offer lower operating costs and less overhead.

### **1.5. Electric Utilities**

Utility operations are usually considered in the three classes of generation, transmission, and distribution, although recent deregulation

has separated generation from the latter two. Figure 1.2 shows a typical hierarchy of voltages and loads. Transmission lines carry the power over the longer distances to substations that step the transmission voltage down to a sub-transmission level. Some high-voltage transmission lines are also the interconnect points between utilities in a regional grid. High-power loads, such as electric arc furnaces and electrochemical plants, may be fed directly from the transmission system. Others are fed from the subtransmission system or from distribution feeders that supply small industries as well as commercial and residential loads. The electric utility systems in this country have grown to a generation capacity of more than 1000 GW at this date. Steam turbines, coal or nuclear powered, and hydraulic turbines supply the vast majority of the motive power for generators, but natural gas fired combustion turbines are growing rapidly as environmental concerns limit additional coal and nuclear power. Much lower levels of power are produced by wind farms, although this area is expanding as the art progresses. Still lesser amounts of power are produced by reciprocating diesel engines in small municipal utilities.

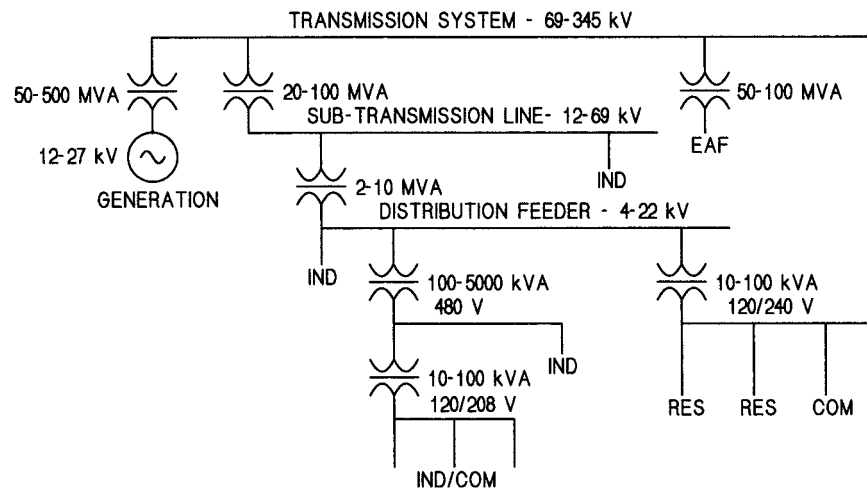

FIGURE 1.2 Typical section of a utility.

The national transmission system is operated cooperatively by regional power pools of interconnected utilities, whereas generation, because of government regulation, is now in the hands of many independent operators. Transmission voltages increased over the years and topped at around 230 kV for some time. The construction of the Hoover Dam, however, made it possible to augment the Los Angeles energy supply with hydroelectric power. When installed in the late 1930s, this line was the longest and, at 287 kV, the highest voltage line in this country. A considerable amount of research went into the insulation system and the conductor design to minimize corona losses. Progressively higher transmission voltages have been introduced until switchgear standards have now been developed for 800 kV service. Transmission lines at or above 500 kV are termed EHV for *extra high voltage*. A major EHV project in the U.S. is the 905-mile Pacific Intertie from the Bonneville Power Administration in Washington to the Los Angeles area. Two 500-kV transmission lines supply some 2500 MW, bringing hydroelectric power from installations on the Columbia River to the major load centers in Southern California. Hydro-Québec operates a large system of 765-kV transmission lines to bring hydroelectric power from northern Québec to load centers in Canada and the U.S.

Although most transmission lines are referred to by their nominal transmission voltage, they are designed for a given *basic insulation level (BIL)* in consideration of lightning strokes and switching transients. Lightning strokes have been measured at voltages of 5 MV, currents of 220 kA, and a maximum  $dv/dt$  of 50 kA/ $\mu$ s, so they have the potential for doing serious damage. Lightning arresters are discussed in Chapter 2.

High-voltage DC (HVDC) transmission lines have come into service through the advent of power electronics. These have an advantage over AC lines in that they are free from capacitive effects and phase shifts that can cause regulation problems and impair system stability on faults. An early HVDC transmission line ran from BPA sites in Washington to Sylmar, CA, a few miles north of Los Ange-

les, to supplement the AC Pacific Intertie. It is rated 1200 MW at  $\pm 400$  kVdc. The converter station at Sylmar was originally built with mercury vapor controlled rectifiers but was destroyed by an earthquake. It was rebuilt as one of the early silicon controlled rectifier (SCR) converters used in HVDC service. Some other large HVDC installations are in Japan from Honshu to Hokkaido; in Italy from the mainland to Sardinia; and between North Island and South Island in New Zealand. Hydro-Québec operates an HVDC system,  $\pm 450$  kV, 2250 MW, from Radisson station near James Bay 640 miles to a 1200-MVA converter station at Nicolet, then 66 miles to a 400-MVA converter station at Des Cantons, an interchange point to the New England Power Pool in Vermont. From there, it continues through Comerford, NH, and finally terminates in the last converter station at Ayer (Sandy Pond), MA, northwest of Boston. In a sense, we have come full circle on DC power.

Residential customers of electric utilities are generally billed on the basis of kilowatt hours, independent of the power factor of their loads. Many industrial customers, however, are billed in two parts. First, they are billed for energy consumed on the basis of kilowatt hours for the billing period. Such charges are in the vicinity of 3 to 5 cents per kilowatt-hour at this time. They basically pay for the utility fuel cost of coal, gas, or oil and some of the generation infrastructure. Even hydroelectric power is not free!

The other portion of most bills is a demand charge based, typically, on the maximum half-hour average kilowatt load for the billing period. This is recorded by a demand register on the kWhr meter that retains the maximum value. Then, this kilowatt demand is adjusted upward, roughly by the reciprocal of the average power factor over the month. A typical metropolitan demand charge is \$5 to \$15 per month per power factor adjusted peak kilowatt demand. This charge supports the transformers, transmission lines, and distribution system necessary to deliver the power. The power factor adjustment recognizes the fact that it is amperes that really matter to the delivery system. Demand charges often provide a powerful incentive for industrial

customers to improve their power factor, since the installation of capacitors may result in a rapid payoff. This example is merely illustrative, however, and there are many variations in billing practices among the electric utilities in this country. Utility representatives are generally helpful in providing advice to minimize a power bill. This matter is further discussed in Chapter 14.

A growing problem in the U.S. is the increasing demands being placed on the transmission system. Prior to deregulation by the government, most utilities generated and transmitted their own power with interconnections to other utilities for system stability and emergency sources. The freewheeling market now present for generation has often resulted in the remote generation of power to loads that would have been supplied by local generation. The result is overloaded transmission lines and degraded system stability. Building additional transmission lines has been made increasingly difficult by *not in my back yard (NIMBY)* reactions by the public. Also, there is little incentive for utilities to install transmission lines to carry power that they cannot bill to their customers. Despite these problems, additional transmission capacity is vital to maintaining a high level of reliability in the interconnected systems.

The entire northeast portion of the U.S. was darkened by a major power outage on 14 August 2003 that cost billions of dollars in lost production and revenue. The problem turned out to be simply poor maintenance of the right of way under some major transmission lines by an Ohio utility. A large hue and cry was raised about the “antiquated” transmission system, but the fact of the matter is that the electric utility industry has achieved a remarkable record of reliability in view of the changed conditions resulting from deregulation. However, the challenge for the future is to do even better.

A significant advance in system stability has come from the development of FACTS converter systems. This acronym for *flexible AC transmission systems* describes power electronics control systems that are able to effect very rapid changes in system voltages and phase angles. Voltages can be maintained through fault swings, and power



oscillations can be damped. System stability can be maintained even with increased transmission line loadings. FACTS installations can defer or eliminate the need for additional transmission lines that are difficult to install because of environmental concerns, permitting processes and right-of-way costs.

### 1.6. In-Plant Distribution

Power distribution systems in industrial plants vary widely. Some of the more popular systems follow. At the bottom of the power ratings, distribution will be at 120/240-V single-phase, lighting loads being connected at 120 V and small motors at 240 V. Three-phase 120/208-V distribution, widely used for lighting at 120 V, can also supply three-phase motors at 208 V, since many induction motors are dual rated for 208/240 V. The 120/208-V neutral is usually solidly grounded for safety of lighting circuits. A 277/480-V distribution system is probably the most popular one for medium-sized industrial plants. The wye secondary neutral is usually solidly grounded, although a resistance or reactance ground is sometimes used. The most common distribution voltage in Canada is 600 V.

Older plants often have a 2300-V, three-phase system, delta connected with no ground. Some, however, may ground one corner of the delta. Distribution at 2400/4160 V is the most popular system at the next higher power level. At still higher powers, older plants often have 6900 V or 7200 V distribution, although the trend is toward 13.8 kV in newer plants. The supplying utility usually installs a fused distribution transformer for lower powers, but the higher-power installations will utilize padmount transformers with circuit breakers and protective relays.

The typical distribution arrangement of a medium-size plant is to bring the incoming power to a number of distribution centers known as *load centers* or *motor control centers*. These consist of a series of circuit breakers or load break switches in metal cabinet sections, some containing the control for a motor circuit. The center may also provide

protective relays and instrumentation. It may have one or more breakers to serve lighting circuit transformers scattered throughout the building. Lighting circuits at 120/208 V are collected in panel boards, with a master breaker serving a multiplicity of molded case circuit breakers. A lighting panelboard may be rated at 100 to 400 A with individual lighting circuits of 20 to 30 A and air conditioning or similar loads at higher currents.

Internal wiring practices use either plastic or metal conduit or cable trays. Conduit is used for the lower power levels with conductors pulled through the rigid tubing. An advantage of conduit is that it protects the conductors from dripping water and mechanical injury. More common at the higher power levels are cable trays. Here, the sizes of conductors are almost unlimited, since they are simply tied down in the trays to prevent movement on faults. The trays themselves are simple angles and cross braces with open construction to aid ventilation. If high- and low-voltage circuits are run together in either conduit or cable trays, all conductors must be rated for the maximum voltage.

### **1.7. Emergency Power**

There are three levels of reliability to consider for emergency power. First, there is the power required for mandatory emergency exit signs and interior lighting in the event of a power outage. This is often supplied from an engine generator set powered by natural gas with automatic starting in the event of an external power failure. Battery backup may be used. Larger installations may have diesel engine-generator sets. A short loss of power is acceptable for these purposes. It is important to test these systems periodically to ensure their availability when needed.

The second reliability level of emergency power is the maintenance of operations in an industrial plant where loss of production is expensive. The usual procedure is to provide two separate power feeders to the plant from separate utility lines. Transfer breakers are used to switch from an ailing circuit to a live one. A momentary power inter-

ruption may be acceptable with only a minor inconvenience to production. Diesel engines or combustion turbines and generators may also be used for plant generation where warranted. If a momentary outage cannot be tolerated, solid-state transfer switches can be used for subcycle switching.

The highest level of reliability is required for critical operations that cannot stand any interruption of power whatsoever. These may be computers in a data processing center or wafer fabrication in a semiconductor plant where even a momentary outage can cost millions of dollars. It is necessary to provide absolutely uninterrupted power to these facilities. One system that is gaining acceptance is to utilize fuel cells operating on natural gas to generate DC power. This power can then be converted to AC with power electronics and used to supply the plant. Critical loads can be powered from two directions as with a utility supply and controlled with solid-state transfer switches. In some cases, excess generation is available from the fuel cells, and the power can be sold to the utility. Many variations on this scheme are being used at this time.



## Chapter 2

---

---

# Power Apparatus

Much of the design work in power electronics involves specification of ancillary apparatus in a system. It is essential to a successful design that the engineer knows the general characteristics of these components well enough to permit selection of a suitable device for the intended application. The components in this chapter are usually described in detail in vendor catalog information, but the designer must know the significance of the ratings and how they apply to the job at hand. Competent vendors can be valuable partners in the design process.

Commonly used symbols in power electronics diagrams are shown in Fig. 2.1. The utility breaker symbol is generally used in single line drawings of power sources, whereas the industrial symbol is used on schematics. There are no hard and fast rules, however, and there are a number of variations on this symbol set.

### 2.1. Switchgear

The equipments intended to connect and disconnect power circuits are known collectively as *switchgear* (please—not *switchgears* and not *switch-gear*). Switchgear units range from the small, molded-case circuit breakers in a household panelboard to the huge, air break

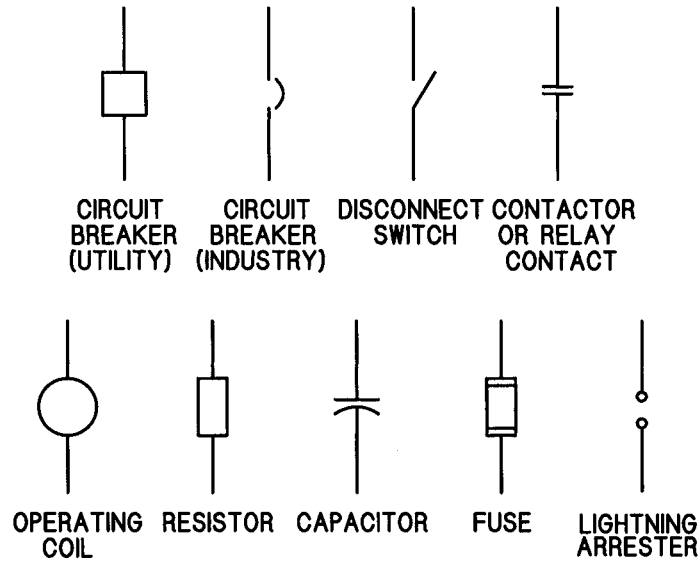

FIGURE 2.1 Power electronics symbols.

switches on 750-kV transmission lines. They are generally divided into the four groups of *disconnect* or *isolator* switches, *load break* switches, *circuit breakers*, and *contactors*.

Disconnect or isolator switches are used to connect or disconnect circuits at no load or very light loads. They have minimum arc-quenching capability and are intended to interrupt only transmission line charging currents or transformer exciting currents at most. They are usually the least expensive type of switch. Mechanically, they are designed to provide sufficient contact pressure to remain closed through fault currents despite the high mechanical forces these currents may cause. Simple knife switches rely on multiple leaves for contact and frictional forces to maintain contact. Others types have over-center latches, while still others have clamping locks that toggle toward the end of the closing cycle. All operate in air and have visible contacts as a safety provision, although low-voltage safety switches rely on handle position. All have provisions for lockout.

Medium- and high-voltage disconnect switches are available as indoor designs that are typically mounted in metal switchgear enclo-

tures or as outdoor switches incorporated into elevated structures. Both horizontally and vertically operating switches are available in outdoor designs, and most are available with motor operators. Some have optional pneumatic operators.

Load break switches generally follow the basic design arrangements of disconnect switches except that they are equipped with arc chutes that enable them to interrupt the current they are designed to carry. They are not designed to interrupt fault currents; they must remain closed through faults. Again, motor operators are available in most designs. Motor-operated load break switches can be a lower-cost alternative to circuit breakers in some applications where remote control is required.

Circuit breakers are the heavy-duty members of the switchgear family. They are rated thermally for a given continuous load current as well as a maximum fault current that they can interrupt. The arcing contacts are in air with small breakers, but the larger types have contacts in a vacuum or in oil. High-voltage utility breakers may utilize sulfur hexafluoride ( $\text{SF}_6$ ) gas. Most breakers have a stored energy operating mechanism in which a heavy spring is wound up by a motor and maintained in a charged state. The spring energy then swiftly parts the contacts on a trip operation. Typically, the circuit is cleared in 3 to 5 cycles, since rapid interruption is essential to minimize arc heating and contact erosion. Indoor breakers are usually in metal cabinets as part of a switchgear lineup, whereas outdoor breakers may be stand-alone units.

Some caution should be used when specifying vacuum circuit breakers. When these breakers interrupt an arc, the voltage across the contacts is initially quite low. As the current drops to a low value, however, it is suddenly extinguished with a very high  $di/dt$ . This current is termed the *chop current*, and it can be as high as 3 to 5 A. If the breaker is ahead of a transformer, the high  $di/dt$  level can generate a high voltage through the exciting inductance of the transformer, and this can be passed on to secondary circuits. The required voltage control can be obtained with arresters on the primary or metal oxide

varistors (MOVs) on the secondary of the transformer. The MOV should be rated to dissipate the transformed chop current at the clamping voltage rating of the MOV. It also must be rated for repeated operations while dissipating the  $1/2 LI^2$  energy of the primary inductance where I is the chop current.

Molded case breakers are equipped with thermal and magnetic overload elements that are self-contained. They are rated by maximum load current and interrupt capacity. Thermal types employ selectable heaters to match the load current for overload protection. Larger breakers are operated from external protective relays that can provide both overload and short circuit protection through time overcurrent elements and instantaneous elements. Nearly all relays are operated from current transformers and most are now solid-state.

Because of their heavy operating mechanisms, circuit breakers are not rated for frequent operation. Most carry a maximum number of recommended operations before being inspected and repaired if necessary. Also, after clearing a fault, breakers should be inspected for arc damage or any mechanical problems.

The real workhorses of switchgear are the contactors. These are electromagnetically operated switches that can be used for motor starting and general-purpose control. They are rated for many thousands of operations. Contactors can employ air breaks at low voltages or vacuum contacts at medium voltages. Most have continuously energized operating coils and open when control power is removed. Motor starters can handle overloads of five times rated or more, and lighting contactors also have overload ratings for incandescent lamps. The operating coils often have a magnetic circuit with a large air gap when open and a very small gap when closed. The operating coils may have a high inrush current when energized, and the control power source must be able to supply this current without excessive voltage drop. Some types have optional DC coils that use a contact to insert a current reducing resistor into the control circuit as the contactor closes.



Any piece of electrically operated switchgear, whether breaker or contactor, has inductive control circuits that can develop high voltages in control circuits when interrupted. Good design practice calls for R/C transient suppressors on operating coils or motors. MOVs will limit the developed voltage on opening but will be of no help in limiting the  $di/dt$  that may interfere with other circuits. Contactors may be mounted within equipment cabinets or as standalone items.

## 2.2. Surge Suppression

Transient overvoltages can arise from a number of sources. Power disturbances result from lightning strokes or switching operations on transmission and distribution lines. Switching of power factor correction capacitors for voltage control is a major cause of switching transients. All utility lines are designed for a certain *basic insulation level (BIL)* that defines the maximum surge voltage that will not damage the utility equipment but which may be passed on to the customer. Some consideration should be given to the supply system BIL in high-power electronics with direct exposure to medium-voltage utility lines. Such information is generally available from the utility representative. The standard test waveform for establishing BIL capability is a voltage that rises to the instantaneous BIL value in 1.2  $\mu\text{s}$  and decays to half that value in another 50  $\mu\text{s}$ .

Other sources of transient overvoltages may lie within power electronics equipment itself. Interrupting contactor coils has already been mentioned. Diode and SCR reverse recovery current transients can also propagate within equipment. Arcing loads may require shielding of control circuits. In general, a solid grounding system will minimize problems.

Apparatus for surge protection covers the range from the little discs in 120-V power strips for computers to the giant lightning arresters on 765-kV transmission lines. Many types now utilize the nonlinear characteristics of MOVs. These ZnO ceramic elements have a low

leakage current as the applied voltage is increased until a threshold is reached at which the current will increase rapidly for higher voltages. The operating voltage is controlled by the thickness of the ceramic disk and the processing. MOVs may be stacked in series for higher voltages and in parallel for higher currents.

Lightning arresters are classified by their current rating at a given clamping voltage. Station-class arresters can handle the highest currents and are the type used by utilities on transmission and subtransmission lines. Intermediate-class arresters have a lesser clamping ability and are used on substations and some power electronics that are directly connected to a substation. The lowest clamping currents are in distribution-class arresters that are used on distribution feeders and the smaller power electronics equipment. The cost, of course, is related to the clamping current. Arresters are rated for their clamping voltage by class and for their *maximum continuous operating voltage*, *MCOV*. They are typically connected line-to-ground. Lightning arresters are often used to protect dry-type transformers in power electronic equipment, because such transformers may have a lower BIL rating than the supply switchgear. In 15-kV-class equipment, for example, the switchgear may be rated for 95 or 110 kV BIL, whereas the transformer may be rated for only 60 kV.

As a design rule, MOVs used for the protection of power electronics will limit peak voltage transients to 2 1/2 times their maximum continuous rated rms voltage. They may be connected either line-to-line or line-to-ground in three-phase circuits. Line-to-line connections limit switching voltage transients best but do not protect against common-mode (all three lines to ground) transients. On the other hand, the line-to-ground connection that protects against common-mode transients does not do as good a job on applied line transients. For optimum protection in equipments with exposure to severe lightning or switching transients, both may be appropriate. The volt-ampere curves for a MOV should be checked to be sure the device can sink sufficient current at the maximum tolerable circuit voltage to handle the expected transient energies. This current will be a function of the

MOV size, and a wide range of diameters is available to handle nearly any design need. Small units are supplied with wire leads, whereas the larger units are packaged in molded cases with mounting feet and screw terminals for connections.

Another device in the protection arsenal is the surge capacitor. Transient voltages with fast rise times, high  $dv/dt$ , may not distribute the voltage evenly among the turns on a transformer or motor winding. This effect arises because of the turn-to-turn and turn-to-ground capacitance distributions in the winding, an effect described in Chapter 7. Surge capacitors can be used to slow the  $dv/dt$  and minimize the overvoltages on the winding ends. These are generally in the range of 0.5 to 1.0  $\mu\text{F}$  for medium-voltage service. Some care should be exercised when these are used with SCR circuits because of the possibility of serious overvoltages from ringing. Damping resistors may be required.

### 2.3. Conductors

Current-carrying conductors range from the small wires of home circuits to massive bus bar sets that may carry several hundred kiloamperes. Copper is the primary conductor, with aluminum often used for bus bars and transformer windings. Conductor cross-sectional areas are designated by American Wire Gauge (AWG) number in the smaller sizes, with a decrease of three numbers representing a doubling of the cross-sectional area. Numbered sizes go up to #0000, 4Ø (four aught). For larger conductors, the cross sections are expressed directly in circular mils,  $D^2$ , where  $D$  is the conductor diameter in thousandths of an inch. For example, a conductor 1/2 inch in diameter would be 250,000 circular mils. This would usually be expressed as 250 kcm, although older tables may use 250 mcm. For noncircular conductors, the area in circular mils is the area in square inches times  $(4/\pi) \times 10^6$ .

High-current conductors are usually divided into a number of spaced parallel bus bars to facilitate cooling. A rough guide to current

capacity for usual conditions is  $1000 \text{ A/in}^2$  of cross section. Connections between bus bar sections should be designed to avoid problems from differential expansion between the conductors and the bolts that fasten them, as both heat up from current or ambient temperature. Silicon bronze bolts are a good match for the temperature coefficient of expansion of copper, and they have sufficient strength for good connections. However, highly reliable connections can be made between copper or aluminum bus sections with steel bolts and heavy Belleville washers on top of larger-diameter steel flat washers. The joint should be tightened until the Belleville washer is just flat. Ordinary split washers are not recommended. If the bus is subjected to high magnetic fields, stainless steel hardware should be used, but the field from the bus itself does not usually require this. Environmental conditions, however, may favor stainless.

All joints in buswork must be clean and free of grease. Joints can be cleaned with fine steel wool and coated with a commercial joint compound before bolting. Aluminum bus must be cleaned free of all oxide and then immediately protected with an aluminum-rated joint compound to prevent oxide formation.

Most control wiring is made with bare copper stranded conductors having 300- or 600-V insulation, much of which is polyvinyl chloride (PVC). These conductors are generally listed by Underwriter's Laboratories, the Canadian Standards Association, or both. Most equipment standards require labeled wire that carries a UL or CSA printed listing number along with AWG gauge and insulation temperature rating (see Fig. 2.2). The National Electric Code should be followed for the required current rating of the conductors. Power wiring is similar to control wiring except, of course, for being much larger. Cabinet wiring is often limited to about 250 kcm because of the necessary tight bending radii, although there are no hard rules on this.

ROME AWM 20 AWG 600 V FR-1 105°C (UL) AWM E-11755 CSA TEW 105°C ZZ 15213

FIGURE 2.2 Typical wire labeling.

In sequence, these identify the vendor, appliance wire, wire size, voltage rating, fire retardant class, insulation temperature, Underwriter's Laboratories as a listing agency, appliance wire listing number, CSA as a listing agency, alternate use as control circuit wire, maximum operating temperature, and listing identification.

Stranded conductors should be terminated in pressure-swaged crimp connectors that then can be bolted to bus work or terminal blocks. Circuit breakers and other power devices often have provisions for fastening stranded conductors with clamp plates or pressure bolts with rounded ends. Swaged connectors should not be used on these terminals. Fine-strand, extra-flexible welding cable should never be used with clamp plates. Pressure-crimped connectors are imperative.

Medium-voltage conductors rated to 7.5 kV are available either shielded or unshielded, but higher-voltage cables must be shielded unless air spaced from other conductors and ground. Spacings must follow standards. Shielded conductors have a center current-carrying conductor, a layer of insulation, and then a conductive shield covered by an insulated protective layer. The shield is grounded. This arrangement assures that the radial electrostatic field is uniform along the length and that there are no voids in the insulation to cause corona deterioration. Terminations are made with stress cones, devices of several types that gradually increase the insulation radius to an extended shield while maintaining void-free conditions. When the radius is sufficient to reduce the voltage stress to allowable levels, the shield can be ended and conventional terminal lugs attached to the extended insulated conductor. Some stress cones have shrink-fit tubing and others a silicone grease to eliminate voids. Figure 2.3 shows a typical arrangement.

The forces between current-carrying conductors vary as the square of the current, so bracing for fault currents becomes a serious issue in high-power equipment. Electronic systems such as motor starters that are connected directly to a power line may face especially high fault currents. Circuit breakers require several cycles to trip and are of no

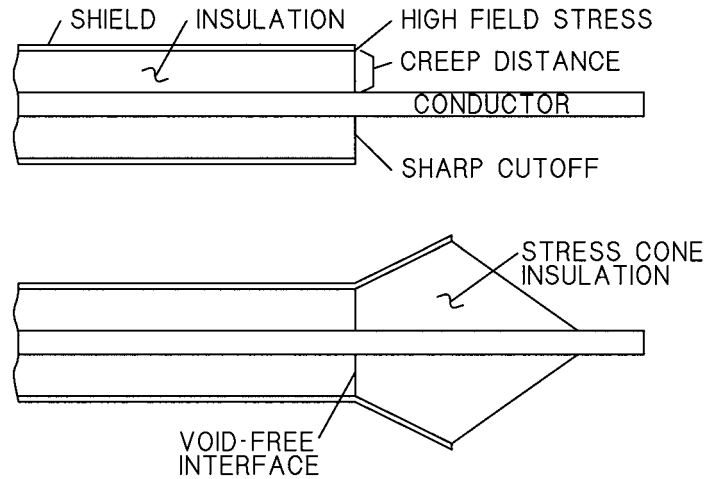

FIGURE 2.3 Stress cone termination for shielded cable.

use in limiting initial fault currents. Ordinary fuses also have relatively long melting times and do not help. On the other hand, semiconductor-type fuses will melt subcycle and limit fault current, the magnitude of which is a function of the prospective fault current without a fuse. The force in pounds per linear foot developed between two parallel round conductors with spacing  $d$  in inches is

$$F = 5.41 I^2 \times 10^{-7} / d$$

where  $I$  is the rms fault current in each. The force is dependent on the conductor geometry. Forces are attractive for currents in the same direction and repulsive for opposite polarities.

When equipment is supplied from an internal transformer rated for the load current, the steady-state fault current will seldom exceed twenty times rated current ( $1/X_{pu}$ ). However, an inductive source causes an asymmetric fault current that theoretically may reach a maximum of twice the steady-state peak value. Although L/R current decay makes a peak of around 1.5 times steady-state peak more likely, this still allows more than twice the steady-state peak force, since the force is proportional to current squared. Circuit breakers are rated for

a maximum peak current that will allow them to close and latch the mechanism.

High-current conductors are sometimes made with liquid cooling, one form utilizing copper tubing soldered or brazed into grooves that are milled into the edge of the bus. An advantage of liquid cooling in general is that most of the heat generated in the equipment can be transferred to the water, thus minimizing heating of the air in cabinets with power electronics. Liquid cooling also saves on copper.

Buswork carrying high levels of AC currents, especially with a high harmonic content, may cause parasitic heating of adjacent steel cabinet parts due to induced eddy currents. One solution to the problem is to replace the cabinet sections with stainless steel, aluminum, or fiberglass sheet and structural members. Another solution is to interpose a copper plate between the bus and the offending cabinet member. The plate will have high eddy currents, but the low resistance of the copper will minimize losses. Eddy currents in the copper will generate a flux in opposition to the incident flux to shield the cabinet steel.

## 2.4. Capacitors

The three major dielectric types of capacitors are those with various types of film dielectrics used mostly for power factor correction and R/C snubbers, electrolytic types used for filters, and ceramic types in the smaller ratings. The electrolytics have a much higher energy storage for a given volume, but they are not available in voltages above about 500 V and are generally rated for DC service only. They further have leakage currents and limited ratings for ripple current. Still, their high energy density makes them popular for filters on DC power supplies. Even when operated at rated conditions, electrolytic capacitors have a definite lifetime, because the electrolyte will evaporate over time, especially if the capacitors are operated at high ripple currents or in high ambient temperatures. Design consideration should be given to adequate ventilation or heat sinking.

Film dielectric power factor correction capacitors have replaced most of the earlier types made with paper dielectric. These capacitors are rated by kilovar (kvar) at rated voltage and are available both as single units and three-phase assemblies in one can. Power factor correction capacitors are always fused, either with standard medium-voltage fuses or with expulsion fuses in outdoor installations. The latter discharge a plume of water vapor when ablative material in the fuse tube is evaporated as the fuse clears a fault.

Capacitors applied to a power system can create problems in the presence of harmonics generated by nonlinear loads. The capacitor bank will form a parallel resonance with the source inductance of the utility supply, and if this resonance falls on a harmonic of the line frequency at which harmonic currents are present, the result can be serious overvoltages and/or overcurrents. Good engineering practice is to make a harmonic voltage survey before installing power factor correction capacitors.

Power factor capacitor ratings are described in IEEE 18-2002, *IEEE Standard for Shunt Power Capacitors*. In summary, they may be operated at maximum conditions of 110% rated rms voltage, 120% of rated peak voltage, 135% of rated kvar, and 180% of rated rms current. Each of these ratings must include any harmonic voltages or currents. When a capacitor is used with a series inductor to form a series resonant harmonic current trap, the increase in voltage at power frequency caused by the inductor must be considered. Most third-harmonic filters and some fifth-harmonic filters may require capacitors rated above the nominal circuit voltage.

Energizing a section of a capacitor bank when the remainder of the bank is on line can result in damaging transient currents. When a single capacitor is connected to a power line, the surge current is limited by the impedance of the source. Within a capacitor bank, however, the only impedance limiting switching current is the small inductance and resistance of the buswork between sections. The charged capacitors will discharge into the incoming capacitor with little current limiting. Each switched section within a capacitor bank should be protected



with a current-limiting reactor. Surge currents should be kept within the instantaneous ratings of the capacitors and switchgear.

Some capacitors designed for DC operation are made with a very long sandwich of conductive and dielectric strips rolled into a cylinder. Connections are made at one end of the two conductive strips, a “tab foil” design. Other types are made from a dielectric strip with a foil or deposited film of metal on one side. The film type can evaporate a small area of the metal on an internal failure without damage, and they are advertised as being self-healing. Capacitors designed for R/C snubber circuits, however, are often required to carry high rms currents and must be so rated. These capacitors are also formed from a sandwich of aluminum foil strips and film dielectric rolled into a cylinder, but the foil layers are offset axially so that the connections to the two foil windings can be made all along the two edges of the winding. This arrangement, known as *extended foil*, lowers the inductance of the capacitor, and the resistive losses are much lower because the current does not have to flow in from one end of the winding. The two constructions are shown in Fig. 2.4. In general, DC-rated capacitors should not be used for AC service or R/C snubbers unless they also have an acceptable AC voltage and current rating. Note that snubber capacitors are subjected to repetitive charge and discharge that

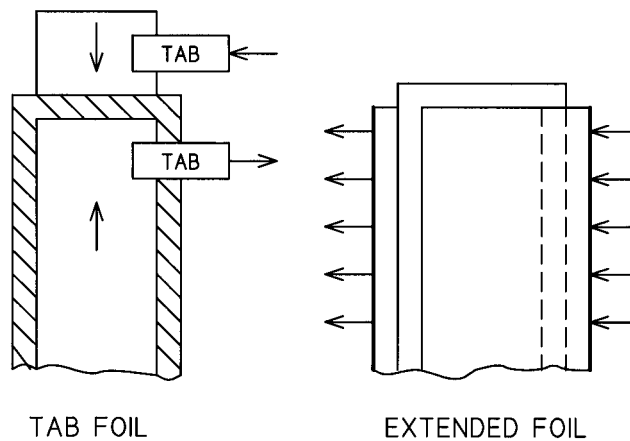

FIGURE 2.4 Capacitor construction.

results in much higher rms currents than would be expected from their capacitance and applied voltage.

All capacitors can be connected in series or parallel for higher voltages or capacitances. They may be freely paralleled, but series connections may require the use of a voltage-sharing resistor connected in parallel with each capacitor. Film types operated on AC circuits may not require sharing resistors for series operation, but resistors are required if DC voltage components are present. Without sharing resistors, the DC voltage will distribute in proportion to the highly variable leakage resistances. Sharing resistors must have a resistance low enough to swamp out the leakage resistance variations to a sufficient degree of voltage uniformity. Design guidance is available from vendors.

Yet another version of capacitors is the ceramic type. Made from ceramic material with a high dielectric constant, ceramic capacitors generally have smaller capacitances but are available in high voltage ratings. Such capacitors have a very low self-inductance and may be desirable for some types of snubbers.

## 2.5. Resistors

Power electronic systems employ a large variety of resistor types and ratings. At the low-power end, they are used in R/C snubber circuits, in voltage dividers, and as damping elements for various resonant circuits. The two general resistor classes in the lower power ranges are wirewound and metallized film. Wirewound resistors are wound from a resistance alloy wire, usually on a cylindrical ceramic body. Terminal connections are welded at each end of a solenoidal winding. Non-inductive wirewound resistors are made with two paralleled windings wound in opposite directions around the body so that their magnetic fields tend to cancel. Another construction technique is to wind the resistor from an elongated hairpin with the loop anchored to one end of the body and the leads brought out at the other end, the two wires

being insulated from each other. There are many variations on these basic construction techniques. Resistors for snubber use, especially with fast switching semiconductors, must have an inductance as low as possible to minimize transient voltages. Metallized film resistors utilize a vacuum deposited resistance metal film on a ceramic substrate. Such metal film resistors have little transient heat storage capacity and are not generally recommended for snubber use. The same is true for carbon film resistors. Carbon composition types are preferred for low-power snubbers. These are made from a bulk carbon cylinder within a ceramic tube.

Ceramic resistors are formed in various configurations from any of a number of conductive ceramics. Metallized sections made by spraying a conductive metal onto the ceramic allow for terminal connections. These resistors tend to have a low inherent inductance that makes them useful for snubbers. Some are housed in cast metal bodies that provide an insulated heat sink for power dissipation.

High-power resistors take on several forms, all of which are designed to permit efficient cooling (see Fig. 2.5). Some in the power ranges up to a few kilowatts are made with rectangular conductors of resistance alloy wound into an air core cylinder with appropriate insulators and supports. Resistors with still higher power ratings are made from stamped sheet metal resistance alloys, sometimes stainless steel, assembled into stacks with series, parallel, or series/parallel connections for the desired resistance. The general description is *grid resistor*. Iron grid castings preceded this type of construction, and such resistors were often used for starting DC motors on trolley cars.

Water-cooled resistors are useful in equipment with water-cooled semiconductors or for the manufacture of compact testing loads for power electronic systems. Many are made from stainless steel or monel tubing with water flowing inside. In going through such a resistor from end to end, the cooling water may be expected to rise 3.8°C for a dissipation of 1 kW with water flow at 1 gal/min. Exit water temperature should be kept below about 70°C to minimize leaching material from the resistor interior wall.

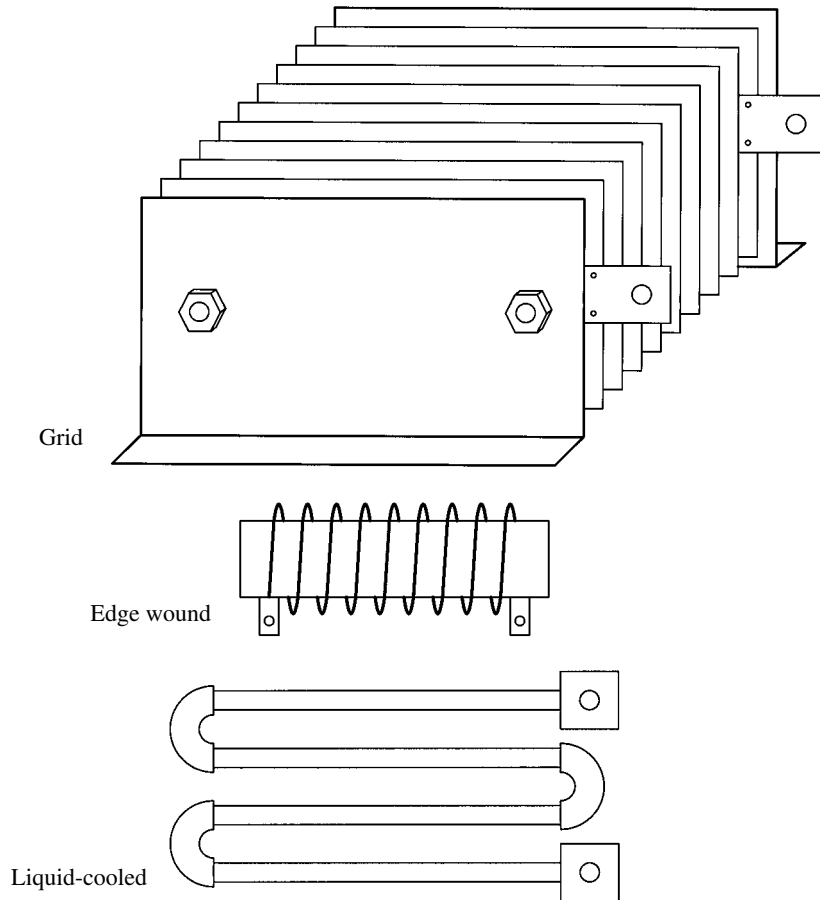

FIGURE 2.5 Power resistor types.

Resistors are also used for heating in many of the process industries. Global<sup>®</sup> silicon carbide resistors are long cylindrical elements, operating at a few hundred volts, that can create temperatures in excess of 1200°C. Sheathed wires similar to an electric stove element with grounded surfaces are also used for annealing, drying, and similar processes. Although not a resistor per se, molten glass is highly conductive and is held at temperature electrically in melters to supply fiberglass nozzles, bottling lines, float glass, and many other glass fabrication industries. Connections are made with silicon carbide rods.

Electric melters are more environmentally friendly than gas-fired units.

## 2.6. Fuses

These protective elements are integral components of power electronics design. They range from the tiny glass cartridge fuses for control circuits to long, medium-voltage types. Each has characteristics that are tailored for the particular applications. Control fuses should be rated for about 125% of the expected load current. Standard types can be used for most control circuits, but *slo-blo* fuses should be used for loads such as small motors and contactor coils that may draw inrush currents.

Semiconductor fuses are a special type that can limit the fault current by clearing subcycle, and they often protect power semiconductors from load faults. Made with multiple thin, silver links embedded in sand with a binder, they melt very quickly on faults and extinguish the arc by evaporating the binder and melting the sand. They are available in a wide range of currents, voltages, and case styles. Most have a ceramic case, and many are designed to fit directly into buswork. Some high-current types are built as matched units, paralleled by the vendor. In pulsed applications, they should not be loaded with an rms pulse current more than 60 to 70% of the melting current for the pulse duration. Steady-state current should not exceed 80% of rated.

If protection of semiconductors is a design objective, the fuse  $I^2t$  rating should be well under the  $I^2t$  rating of the semiconductor. Better coordination can be obtained in SCR converters if each SCR path is fused rather than the supply lines. This arrangement also offers protection from internal bus-to-bus faults when the load can source power.

Medium-voltage fuses are available as “E” rated for transformers and general-purpose applications, and “R” rated for use with applications such as motors with high starting currents. Most mount in clip

assemblies. These fuses may be matched in resistance and paralleled by the vendor for higher currents.

All high-current fuses should be bolted into sanded buswork with joint compound and sufficient pressure to ensure a minimum resistance. Fuses are rated under the assumption that the buswork to which they are mounted will sink heat from the fuse and not source heat into it.

## 2.7. Supply Voltages

The primary operating voltage for most power electronics is divided into two general classes: low-voltage, service voltages of 600 V or less, and medium-voltage, service voltages of 601 V through 34.5 kV. The vast majority of power electronics will wind up on either 600-V, 5-kV, or 15-kV-class supplies in the U.S., but there are applications at 2400 V and 6900 V, especially in older plants. Overseas, many other voltages may be encountered, with 400 V, 3300 V, and 11 kV being popular, all at 50 Hz.

## 2.8. Enclosures

Equipment enclosures are described in NEMA standard ICS 1-110. Briefly, the designer may be expected to encounter Type 1, Type 4, and Type 12 enclosures most often. Type 1 is a general-purpose indoor, ventilated enclosure that protects personnel from accidental exposure to high voltages and protects equipment from dripping water. Type 4 is a watertight, dusttight, nonventilated indoor or outdoor enclosure. Type 12 is a dusttight, driptight indoor enclosure. Type 12 may have nonventilated sections that are dusttight and ventilated sections that are not.

Most enclosures are made with 10 to 12 ga steel, although smaller wall mount cabinets may be 14 ga. Corners and seams are welded,

and free-standing enclosures are equipped with three-point door latches. The rear wall of a cabinet has welded studs that support a removable panel so that component assembly can be done outside the cabinet. All doors should be connected to the enclosure frame with flexible grounding straps for safety. The industry standard for free standing enclosures is 90 inches in height.

## 2.9. Hipot, Corona, and BIL

Any insulation system must be able to tolerate a continually applied voltage, a transient overvoltage, and a surge voltage. Furthermore, it must be free of partial discharge (corona) under the worst-case operating conditions. The hipot test is typically a 1-min application of a 50- or 60-Hz voltage between all conductors and ground, during which the system must not fail shorted or show a fluctuating leakage current. There may, of course, be displacement currents from the capacitance to ground.

Absent a specific high-potential test specification, a rule of thumb is a 1-min, 60-Hz applied sinusoidal voltage of twice rated rms voltage plus 1000 V for equipment rated 600 V or less and 2.25 times rated voltage plus 2000 V for ratings of 601 V and above.

The ability to withstand surge voltages is defined by a test wave with a 1.2  $\mu$ s rise time to peak and a 50  $\mu$ s fall to half voltage. This test approximately defines a basic insulation level (BIL) for the system. The test is a single application of this wave, and the requirement to pass is simply freedom from breakdown.

Yet another test is the voltage at which a certain level of corona begins. This is detected by the appearance of impulse discharge currents on an oscilloscope as the applied voltage is slowly raised. The voltage at which these currents appear is the onset or inception level, and the cessation of the impulses as the voltage is reduced is the offset or extinction voltage. Standardized metering circuits in commercial corona testers allow these impulse currents to be quantified in micro-coulombs of current-time integral.

A simple corona tester can be made that is sufficient for most purposes with only a hipot tester, a filter, and a coupling circuit as shown in Fig. 2.6. The noise filter can be made with a high-voltage resistor and capacitor, and the current demand should be kept below the maximum rating of the hipot tester. The RF choke (RFC) can be any small inductor of from 1 to 100 mH inductance, and the low-pass R/C filter can be used to eliminate the fundamental current from the oscilloscope. Some tinkering of these components can be expected. In operation, corona will be indicated by the appearance of noise spikes as the voltage is raised. The unit can be tested with some twisted hookup wire.

## 2.10. Spacings

Even the lowest-voltage systems require some consideration for the electrical clearances between conductors of different voltage. Standards have been developed by the Canadian Standards Association (CSA), Institute of Electrical and Electronics Engineers (IEEE), National Electrical Manufacturers Association (NEMA), and Underwriter's Laboratories (UL). These standards cover everything from PC boards to high-voltage switchgear.

Spacings are generally considered in two classes: *strike*, the clearance through air paths, and *creep*, the clearance along insulating sur-

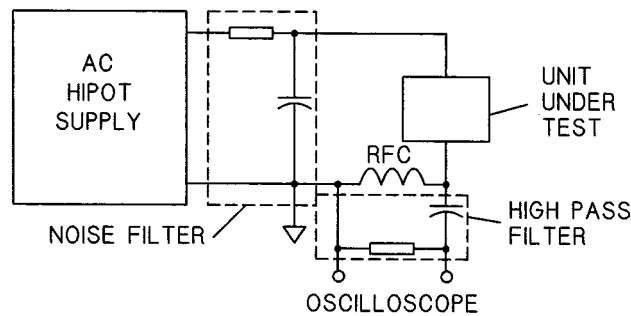

FIGURE 2.6 Simple corona tester.



faces. Whereas the strike capability of an air path between spherical conductors may be much larger than the standards allow, the standards recognize the imperfect world of sharp-edged conductors, conductor movement on faults, voltage transients, and safety margins. Similarly, the creep standards recognize that insulating surfaces may become contaminated by conductive dust or moisture.

Understanding these standards is especially important in applying medium-voltage transformers that are directly connected to customer switchgear. The switchgear is the first line of defense and must cope with lightning and switching transient voltages, but it will pass along these transients to connected equipment. Unless equipment connected to customer switchgear is protected by auxiliary arresters and/or surge capacitors, it must meet the same standards as the switchgear itself. Table 2.1 is taken from the Westinghouse document, “Electrical Clearances for Switchgear,” and, although some years old, it is typical of the several extant standards.

TABLE 2.1 Switchgear Electrical Clearance Standards

<b>Clearances for Insulated Conductors</b>			
5-kV strike 2 in	15-kV strike 3 in	5-kV creep 3.5 in	15-kV creep 5.5 in
<b>Clearances for Uninsulated Conductors</b>			
5-kV strike 3 in	15-kV strike 6 in	5-kV creep 4 in	15-kV creep 6.5 in

The insulated conductors include extruded insulations, insulating boots, and high-voltage taping. The standards recognize that these insulating materials may degrade with continued exposure to high voltages.

## 2.11. Metal Oxide Varistors

Metal oxide varistors (MOVs) are components that have a nonlinear  $V/I$  characteristic. In the case of varistors used for voltage protection,

the voltage varies but little over a very wide range of current. The types used for power electronics are made by pressing and sintering wafers of zinc oxide ceramic with the characteristics determined by the process, the diameter, and the thickness. These devices are available in sizes from those suitable for surface mounting on PC boards to those for large station-type lightning arresters. The range spans sizes from a few millimeters to 90 mm in diameter.

The V/I curve for a typical 60-mm dia., 480-V rated MOV is shown in Fig. 2.7. Note that the current is only 1 A at 1000 V peak and virtually zero at the 680 V peak in a 480-V circuit. However, it will limit the peak voltage to about 1200 V at 1000 A. This means it will protect a 1200-V SCR or other semiconductor from peak transient currents as high as 1000 A. MOVs are generally applied at their nominal rms voltage rating and are expected to clamp transients to a peak voltage of 2.5 times their rms rating.

MOVs have little power dissipation capability, and they can be easily destroyed by repetitive transients such as produced by SCR commutation. MOV catalogs show the lifetime characteristics as a function of the current magnitude and duration. When used for sup-

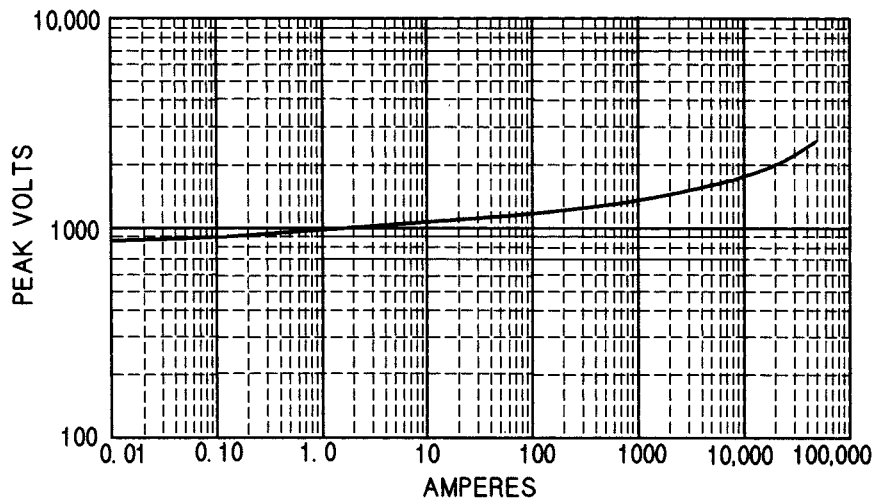

FIGURE 2.7 480-V, 60-mm MOV characteristic.

pressing breaker chop, for example, the maximum lifetime exposure should be calculated so that a suitably sized MOV can be specified.

## 2.12. Protective Relays

Utilities and large industrial plants use a variety of relay types to protect the system and its components against fault currents. The most basic types are overcurrent relays, which are available in a number of styles. All will trip a breaker on overcurrent, but the timing is widely variable among the several types. Relays are available from inverse to extremely inverse according to the design. All trip with a delay on low-current faults but trip more quickly as the fault current rises. Many are available with an auxiliary instantaneous element that will trip subcycle. Nearly all types are now electronic, with power derived from the protected circuit itself. They are usually cascaded with decreasing trip current settings as the system branches out from source to load through a succession of buses and circuit breakers. This allows an overcurrent to be cleared as close to the fault as possible so as to avoid disturbing other loads.

Another useful type is the differential relay. This relay has two sets of current coils and will trip on current imbalance between the two sets. When equipped with suitable current transformer ratios on the two sets, it can protect a transformer or generator from internal faults and distinguish between them and external faults. Most differential relays have delay elements to allow for inrush currents in transformers.

Electric utilities often use impedance or distance relays to protect transmission and distribution circuits. Although computers now take over many of these tasks, the principle remains the same. The impedance relay has both current and voltage coils, with the voltage coils used as restraint elements. If the voltage is high enough, the current coils are inhibited from tripping the associated breaker. In a sense, this relay measures the impedance and hence the distance to the fault, and

it can decide whether a downstream breaker can clear the fault with less disturbance to the system.

Relays are identified on system single-line diagrams as type 50 for instantaneous overcurrent relays, 51 for time overcurrent relays, 64 for ground fault relays, 87 for differential relays, and 21 for impedance or distance relays. The relay designations are usually shown adjacent to the circuit breaker they trip, with instantaneous and time overcurrent relays shown as 50/51. Undervoltage, phase balance, phase sequence, directional power, and frequency relays are but a few of the many other types available.

This essay has been a bit cavalier in equating, by implication, impedance to reactance. In most power systems work, the resistive losses are small enough to have little effect on fault currents or regulation, so impedance is often considered as reactance in calculations. The same is true of commutation in converters where resistance does play a small role.

## Chapter 3

---

---

# Analytical Tools

Several specialized analytical tools have been developed to aid in the solution of power and power electronics circuits. Learning these tools can make the design job easier, especially when studying the interaction between a power electronics system and the supplying utility system. Also, it is necessary to understand these analytical tools and their nomenclature to converse with utility and vendor engineers associated with the power electronics field.

### 3.1. Symmetrical Components

Analysis of a three-phase AC circuit with unbalanced currents or voltages gets into some rather messy complex numbers. In 1918, Dr. C. L. Fortesque delivered a paper before the AIEE, predecessor organization to the IEEE, that laid the groundwork for symmetrical components, a method of representing unbalanced voltage or current phasors by symmetrical sets of phasors. These symmetrical components are positive- and negative-sequence three-phase components as well as a zero-sequence single-phase component. This latter phasor is involved with four-wire systems, usually involving ground circuits. The network can be solved in the usual fashion with each of the symmetrical

components, and then the individual solutions combined to represent the unbalanced system. Symmetrical components are universally used by power company engineers for system parameters.

Symmetrical component analysis uses a complex operator,  $a$ , where  $a = -0.5 + j 0.866$ , a unit phasor at  $120^\circ$ . Then,  $a^2 = -0.5 - j 0.866$ , and  $a^3 = 1.0$ . If a set of asymmetric phasors are given as  $x$ ,  $y$ , and  $z$ , then

$$Ex0 = \frac{(x + y + z)}{3}$$

$$Ex1 = \frac{x + ay + a^2z}{3}$$

$$Ex2 = \frac{x + a^2y + az}{3}$$

where all quantities are phasors.  $Ex0$ ,  $Ex1$ , and  $Ex2$  are referred to as the zero-sequence, positive-sequence, and negative-sequence components of  $x$ , respectively. Then,  $Ex0 = Ey0 = Ez0$ ,  $Ey1 = a^2 Ex1$ ,  $Ez1 = a Ex1$ ,  $Ey2 = a Ex2$  and  $Ez2 = a^2 Ex2$ .

This process is shown in Fig. 3.8 where a (very) unbalanced set of phasors are  $x = 6.0$ ,  $y = -j2.0$  and  $z = -0.707 + j0.707$ . The sequence networks are shown at the right. In this case,

$$Ex0 = 1.764 - j0.431$$

$$Ex1 = 2.899 + j0.419$$

$$Ex2 = 1.337 + j0.011$$

The original asymmetric phasors may then be reconstituted as

$$x = Ex0 + Ex1 + Ex2$$

$$y = Ey0 + Ey1 + Ey2 = Ex0 + a^2 Ex1 + a Ex2$$

$$z = Ez0 + Ez1 + Ez2 = Ex0 + a Ex1 + a^2 Ex2$$

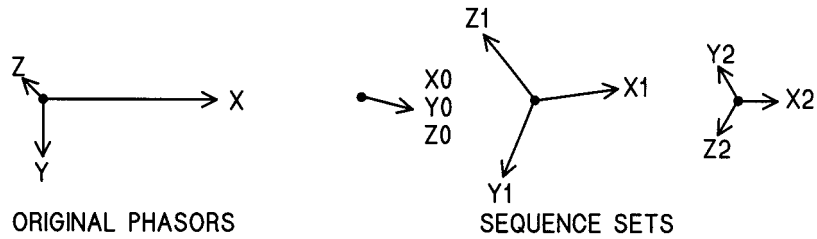

FIGURE 3.1 Symmetrical components.

If the set of phasors just resolved were to represent load impedances, the line currents could be determined by impressing the balanced line voltages onto the three sequence networks separately and adding the three components of each line current.

Symmetrical components are often used to describe the characteristics of overhead transmission lines. For example, the familiar set of three conductors in a horizontal row has equal couplings from the two outer lines to the center line, but they have a different coupling to each other. Hence, the mutual inductances and capacitances of the set are different. The use of symmetrical components of these impedances allows the line to be analyzed as two balanced positive- and negative-sequence networks. The resultant currents can then be combined. Absent a grounded circuit, the zero-sequence network is not present.

The many circuit simulation software packages now available can reduce the need for using symmetrical components for circuit solutions, but they are still valuable for defining the unbalanced loading and fault performances of synchronous machines.

### 3.2. Per Unit Constants

Per unit quantities greatly simplify comparisons between items of power apparatus and aid in solving fault calculations. Per unit is a method of normalizing the characteristics of elements in a power electronics system so they can be represented independent of the particular voltage at that point in the system. Their characteristics are

translated relative to a common base so that extended calculations can be made easily.

In its simplest form, a per unit quantity is merely the percent quantity divided by 100. It spares one the nonsense of 50% voltage times 50% current equals 2500% power. In per unit notation, 0.5 pu voltage times 0.5 pu current equals 0.25 pu power as it should be. A transformer with 6% impedance would have a per unit impedance of 0.06 pu. Although not described as such, this impedance is based on the rated voltage and current of the transformer. It accommodates the differences in primary and secondary voltages by describing the percent rated voltage in either winding required to produce rated current in that winding with the other winding shorted. The regulation characteristics of the transformer are completely described by this figure. When other elements are added to a system, however, there will be a whole set of different ratings of the various elements. A 500-kVA transformer at 4160 V with 6% reactance may serve a 50-kVA transformer at 480 V with 4% reactance that, in turn, serves a 5-kVA lighting transformer at 120 V with 3% reactance. It is a real nuisance to chase the various voltages and currents back through the system to find, for example, the short circuit current at the final transformer. Per unit quantities make it easy.

First, one must choose a particular power level as a base quantity. The selection is completely arbitrary but is usually related to the rating of one of the component items. In this case, the 50-kVA transformer will be used as the base, and its leakage impedance will be 4% on that base, 0.04 pu. To relate the 5-kVA lighting transformer to this quantity, one simply multiplies the 5-kVA impedance of 0.03 pu on its own base by the power ratio of  $50 \text{ kVA}/5 \text{ kVA} = 10$ . With the two in cascade, the total impedance is now  $0.04 + 0.03 \times 10 = 0.34$  pu. The 500-kVA transformer by the same procedure becomes  $0.06 \times 50/500 = 0.006$  pu on the 50-kVA base. The series string impedance is then  $0.006 + 0.04 + 0.30 = 0.346$  pu on the 50 kVA base. This total series impedance is 0.0346 pu on a 5-kVA base, and a fault on the secondary of the 5-kVA transformer will result in  $1/0.0346 = 28.9$  times rated



current, 28.9 pu on the 5-kVA base. At the 50-kVA transformer, this fault will result in  $1/0.346$  pu = 2.89 pu current on a 50 kVA base, and at the 500-kVA transformer the fault is  $1/3.46 = 0.289$  pu on a 500-kVA base. At any point in the system, one can define a base impedance as  $Z_{base} = V_{LL}^2/VA$  or  $Z_{base} = V_{LL}^2/(1000 \times kVA)$  where VA or kVA is a three-phase rating. Then, in ohms,  $Z_{ohms} = Z_{base} Z_{pu}$  at that base. The base impedance is the impedance that, when connected to each line of a three-phase system at rated voltage, will draw rated load current and develop rated voltamperes.

It is worth the effort to develop a familiarity with the per unit system, because it greatly eases conversations with utility engineers, motor designers, transformer designers, and others associated with power electronics. It is universally used.

### 3.3. Circuit Simulation

Many power electronics circuits can be simulated and studied with relatively simple computer programs. While many engineers prefer to use commercial circuit simulation software packages, there is some merit in being able to write simple code to study circuit operation under transient conditions. The example that follows is written in BASIC, but it can be easily translated to C or any other preferred programming language. It is the concepts of handling the circuit that count.

The schematic of Fig. 3.2 shows a circuit the author designed some years ago. The circuit is an arc heater with a current regulator, and the concern was to define the current overshoot when the arc ignited from applied voltage. The converter was a 24-pulse system that permitted a relatively fast current loop of 2000 rad/s. The system had a nonlinear output inductor, a feedback filter, a transport lag from the SCRs and serial optical links, a negative slew rate limit, and an arc strike voltage. The BASIC program follows. It is heavily annotated to illustrate the approach. Fig. 3.3 shows the output wave-

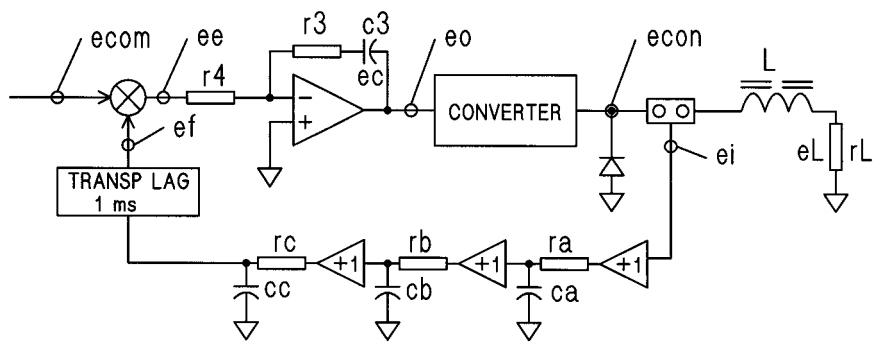
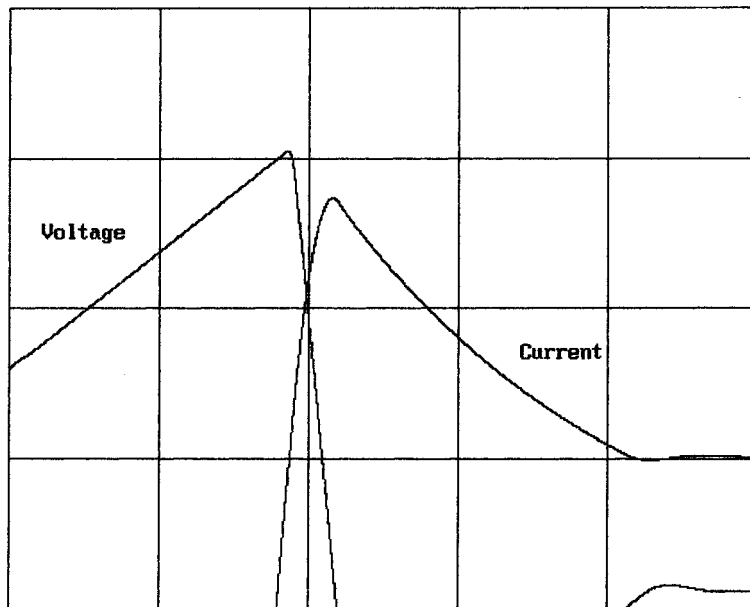

FIGURE 3.2 Arc heater circuit.



Horizontal 20 ms/div, U=200 V/div, I=100 A/div  
ARC HEATER STARTING CHARACTERISTIC

FIGURE 3.3 Circuit voltage and current waveforms.

form with a starting current transient of some 270% of initial set-point, entirely acceptable in this case. Note that the current shows a slight undershoot and then overshoot when falling to the command level once the arc is ignited.

### 3.3.1. Circuit Simulation Notes

Initial voltage:	0 – current integrator enabled at $t = 0$
Initial current:	0.01 A (to get a finite inductance)
Ignition voltage:	600 V
Equivalent arc resistance:	0.25 $\Omega$
Inductor:	Inductance inversely proportional to current to 1.1 power, bounded by 10 mH maximum and 1.1 mH minimum
Feedback:	Three cascaded filter poles at 2000 rad/s. Filter will handle both feedback and anti-aliasing in the digital system.
Transport lag:	1 ms delay in SCRs and digital system, simulated as an actual delay
Regulator:	Lead at 250 rad/s to match 4-ms load time constant
Negative slew rate:	-10%/ms to approximate 50-Hz sine wave
Commanded current:	100 A, a low initial current setting to minimize overshoot

This program will run in BASIC 4.5 or higher as well as QuickBASIC.

```
'Arc heater starting program
SCREEN 12 ' set 640 x 480 screen
PALETTE 0,4144959 ' set reverse palette colors
PALETTE 15,0 'set background white
DIM ed(10000)
td = 100 'delay in 10  $\mu$ s increments
dt = .00001 ' time increment 10  $\mu$ s
icom = 100 ' current command level
ecom = icom / 300 ' current command = .33 v for 100A
rL = .25 ' load resistance
r3 = 40000 ' lead resistor
r4 = 10000 ' input resistor
```

```

ra = 500 ' filter resistors
rb = 500
rc = 500
ca = .000001 ' filter capacitors
cb = .000001
cc = .000001
cd = .000001
c3 = .000001 ' integrator capacitor
i = .01 ' initial current
again:
IF i <= 0 THEN i = 1 ' clip undershoot
L = .01 * (250 / i) ^ 1.1 ' inductor characteristic
IF L > .01 THEN L = .01 ' maximum inductance 10 mH
IF L < .0011 THEN L = .0011 ' minimum saturated
    inductance 1.1 mH
ee = econ - ef ' error signal of command minus
    feedback
ia = (ei - ea) / ra ' filter capacitor current for
    Euler integration
ib = (ea - eb) / rb ' same, next stage
ic = (eb - ec) / rc ' same, final stage
p = n - td ' digital system transport lag
IF p < 1 THEN p = 1 ' initialize
ed(n) = ec ' last stage filter voltage
ef = ed(p) ' delay of td/100 ms
ec = ec + ic * dt / cc ' three cascaded poles of filter
    with poles at 2000 rad/s
eb = eb + ib * dt / cb ' sections are isolated
ea = ea + ia * dt / ca ' Euler integration
ei = .0033 * i ' 1500 A = 5 V feedback from shunt
econ = 240 * eo ' converter gain, 5 v = 1200 V
IF econ < 0 THEN econ = 0 ' commutating diode prevents
    negative voltage
IF econ > 1200 THEN econ = 1200 ' voltage ceiling
IF (i < icom) AND (econ > 650) THEN econ = 650 '
    starting voltage limit
IF econx - econ > 1 THEN econ = econx - 1 ' negative
    slew rate limit 10%/ms
i = i + (econ - eL) * dt / L ' load current
IF econ > 600 THEN k = 1 ' flag to detect first current
    above isetpoint

```

```

IF k = 0 THEN i = 0 ' no current until econ > 600 V arc
    ignition voltage
eL = i * rL ' load voltage
eo = ee * ( r3 / r4 ) + ecap ' output voltage of opamp
IF eo > 10 THEN eo = 10 ' opamp limit
ecap = ecap + (eo - ecap) / r3 * dt / c3 ' voltage on
    integrator cap
PSET ( n / 20 + 50 , 400 - i ) ' plot current
PSET ( n / 20 + 50 , 400 - .5 * econ ) ' plot voltage
n = n + 1
IF n > 10000 GOTO quit: ' end of display
econx = econ ' set econx for prior voltage to set
    negative slew rate maximum
GOTO again:
quit:
FOR n = 0 to 400 STEP 100
LINE ( 50 , n ) - ( 550 , n ) ' ordinate scale
NEXT
FOR n = 50 to 550 STEP 100
LINE ( n , 0 ) - ( n , 400 ) ' abscissa scale
NEXT
LOCATE 27 , 15: PRINT " Horizontal 20 ms/div, V=200 V/
    div, I=100 A/div"
LOCATE 28 , 20: PRINT " ARC HEATER STARTING
    CHARACTERISTIC"
LOCATE 10,10: PRINT "Voltage"
LOCATE 15,50: PRINT "Current"

```

### 3.4. Simulation Software

A number of software packages are now available to simulate the operation of nearly any power electronic circuit. Component characteristics are included, and the programs are set up so that representation of a circuit is relatively easy. All are described on the Internet in some detail, and most have student versions, limited-capability versions, limited-time versions, or introductory packages. The comments that follow must be taken at a point in time, since the software evolves rapidly.

**MATLAB**—An interactive program for numerical computation and data visualization that is used by control engineers for analysis and design. Numerous “toolboxes” such as SIMULINK, a differential equation solver, are available for simulation of dynamic systems. It provides an interactive graphical environment and a customizable set of block libraries that allow for the design, simulation, and implementation of control, signal processing, communications, and other time-varying systems.

**MATHCAD**—An equation-based program that allows one to document, perform, and share calculation and design work. It can integrate mathematical notation, text, and graphics in a single worksheet. It allows capture of the critical methods and values of engineering projects.

**Spice**—One of the early simulation programs, Spice allows a circuit to be built directly on the display screen in schematic form. Libraries are available for the various circuit elements. Both steady-state and transient behavior can be analyzed. Many related programs are also available—PSpice, Saber, and Micro-Cap to name just a few. Some are directly compatible with Spice.

**ElectroMagnetic Transients Program (EMTP)**—Devoted primarily to the solution of transient effects in electric power systems, variants are available for circuit work. It is developed and maintained by a consortium of international power companies and associated organizations. The core program is in the public domain.

The above is only a sampling of the more popular software available for circuit analysis. Most packages can be purchased on the Internet and some have student versions that can be downloaded at no cost.

## Chapter 4

---

---

# Feedback Control Systems

Nearly all systems in power electronics rely on feedback control systems for their operation. This chapter presents the basic analog analysis of such systems because, in this author's opinion, it offers a more intuitive understanding of their behavior than can be obtained from modern control theory with digital techniques.

### 4.1. Basics

Fig. 4.1 shows the simplest feedback control system. A command signal is received by a summing junction and compared to a feedback signal of opposite polarity. The difference signal is sent to an amplifier

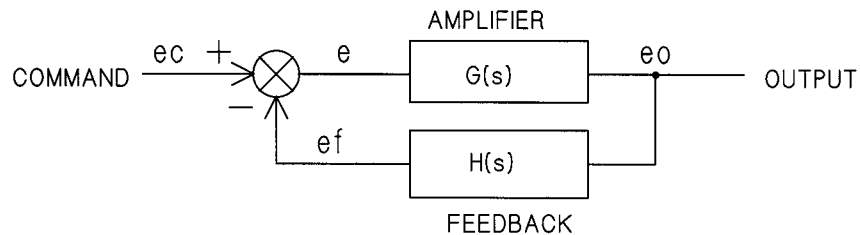

FIGURE 4.1 Basic feedback system.

fier that produces the system output with a feedback signal derived from the amplifier output. Both the amplifier characteristic and the feedback characteristic are functions of frequency and are shown as  $G(s)$  and  $H(s)$ , respectively.

The performance of such system can be derived from an equation that relates output to input. The equation is developed as follows:

1.  $e = ec - ef$
2.  $eo = e \times G(s)$
3.  $ef = eo \times H(s)$
4.  $eo = G(s) \times [ec - eo \times H(s)]$
5.  $eo/ec = G(s)/[1 + G(s) \times H(s)] = A$

where  $eo/ec$  is the closed-loop system gain as a function of frequency.

If the feedback is disconnected from the summing junction, then  $A = G(s) \times H(s)$ , the open-loop gain. Simple systems such as the one shown in Fig. 4.1 can be analyzed for stability and performance by an examination of the open-loop gain characteristic as the frequency is varied. For most purposes, the asymptotic response will suffice.

## 4.2. Amplitude Responses

Figure 4.2 shows the actual and asymptotic responses of a simple R/C circuit consisting of a series 1 M $\Omega$  resistor and a 3.3  $\mu$ F shunt capacitor. Such frequency response characteristics for systems are referred to as *Bode (bodey) plots*.

The plot is in decibels (dB) equal to  $20 \times \log_{10}(vo/vi)$  where  $vo$  and  $vi$  are the output and input voltages, respectively. These may just as easily be currents or currents translated to voltages through shunts or CTs. The asymptotic response is useful, because it can be quickly drawn and has a maximum error of only 3 dB at the break point. The break point in radians per second is simply the reciprocal of the time constant in seconds. Figure 4.3 shows a number of circuit elements and their asymptotic frequency responses.



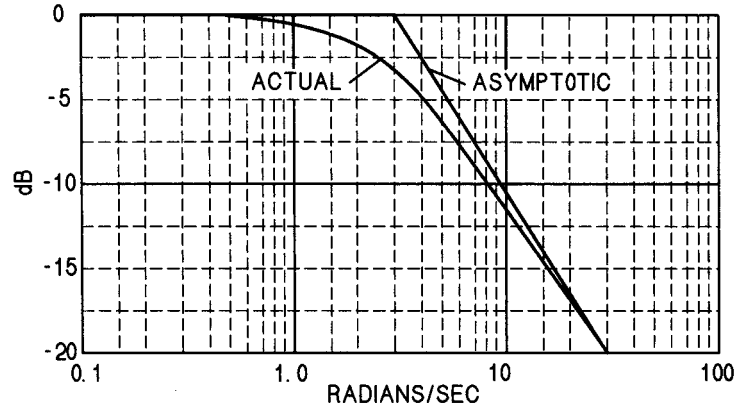

FIGURE 4.2 R/C frequency response.

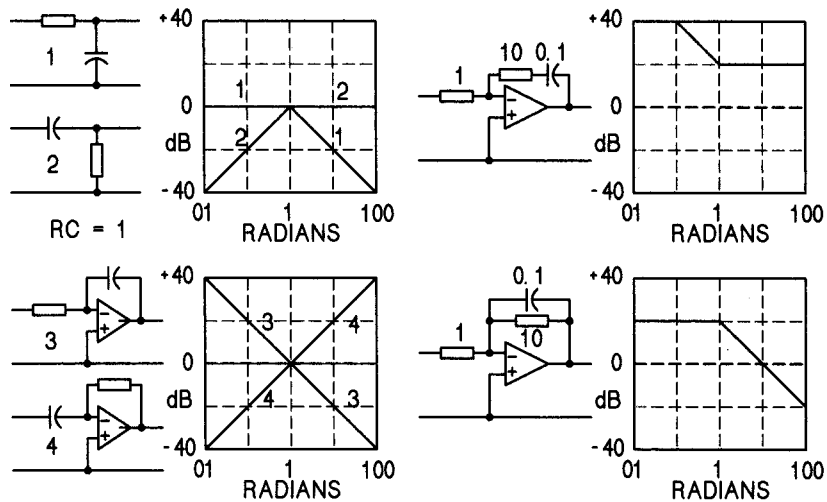

FIGURE 4.3 Frequency responses of various networks.

The asymptotic response of cascaded circuit elements can be determined by simply adding their individual responses. Figure 4.4 shows the process for two elements with different asymptotic responses, 1 and 2, and the response, 3, when they are cascaded.

The time response of a closed-loop feedback system can be deduced from the open-loop frequency response. The primary factor affecting

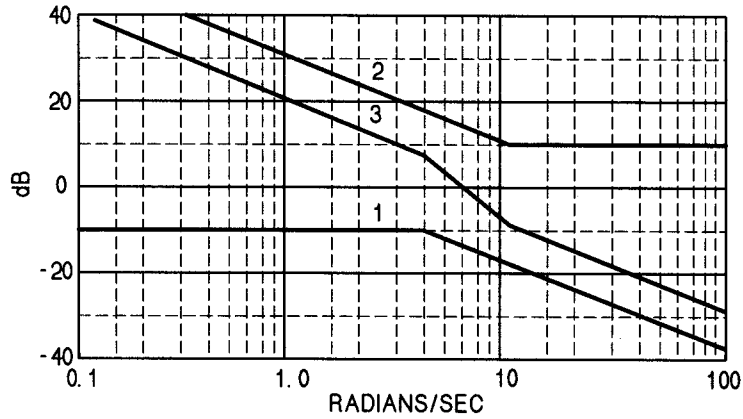
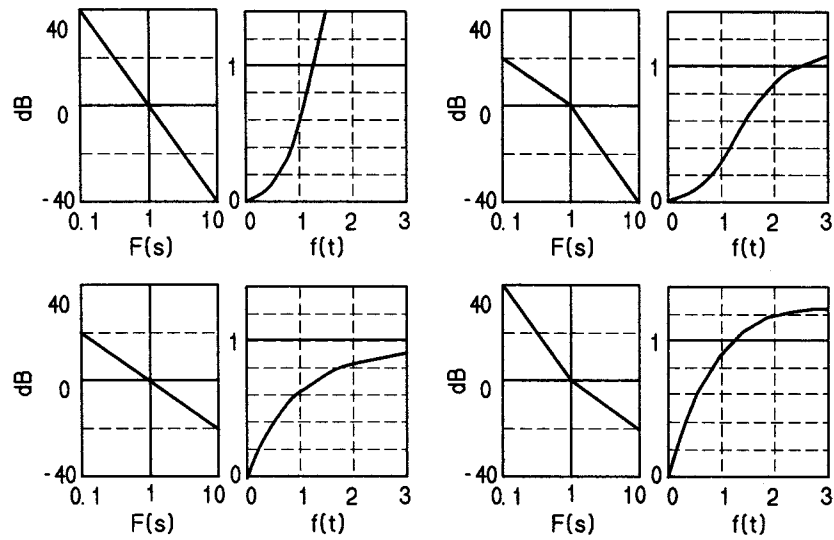

FIGURE 4.4 Composite response.

the time response is the slope of the frequency response as it crosses the zero-dB line, the line of unity gain, and its response in the frequency decade before and after the crossover. Several normalized frequency response characteristics are shown in Fig. 4.5 along with their

FIGURE 4.5 Frequency responses,  $F(s)$ , and corresponding time responses,  $f(t)$ .

corresponding time responses. Frequency plots are in radians/sec and time plots in seconds.

At upper left, the gain crosses the zero-dB axis with a slope of  $-2$ ,  $-40$  dB per decade. The time response is dramatically unstable, and the system takes off for the moon. At upper right, the gain curve approaches the zero-dB axis with a slope of  $-1$  then goes to  $-2$ . The system is stable but with an overshoot. The lack of high-frequency gain results in a poor rise time.

The curve at lower right shows a similar behavior with overshoot. Now, however, the high-frequency gain is better, and the system has a good rise time. Finally, at lower left, the system crosses with a slope of  $-1$ ,  $-20$  dB per decade and is critically damped with a good rise time and no overshoot. These response characteristics can yield some insight into the behavior of more complex systems.

### 4.3. Phase Responses

The amplitude response with frequency is only part of the story, the remainder being the phase response. The curves at lower left in Fig. 4.5 result from a pure integrator, and the phase shift is a constant  $90^\circ$  lag independent of frequency. The characteristic at upper left is equivalent to two integrators in cascade and has a phase shift of  $180^\circ$ . The reason it is unstable is that the feedback voltage now adds directly to the command voltage. Instead of being negative feedback, it is positive, and it makes the system regenerative. The output rises until something saturates, and then the process repeats. The result is an oscillator.

A low-pass filter such as shown at the lower right of Fig. 4.3 has a phase lag of  $45^\circ$  at the break frequency, and the lag approaches  $90^\circ$  for higher frequencies. Filtering signals will always result in a lagging phase characteristic. The actual and asymptotic phase responses of an R/C low-pass filter normalized to one radian per second are shown in Fig. 4.6.

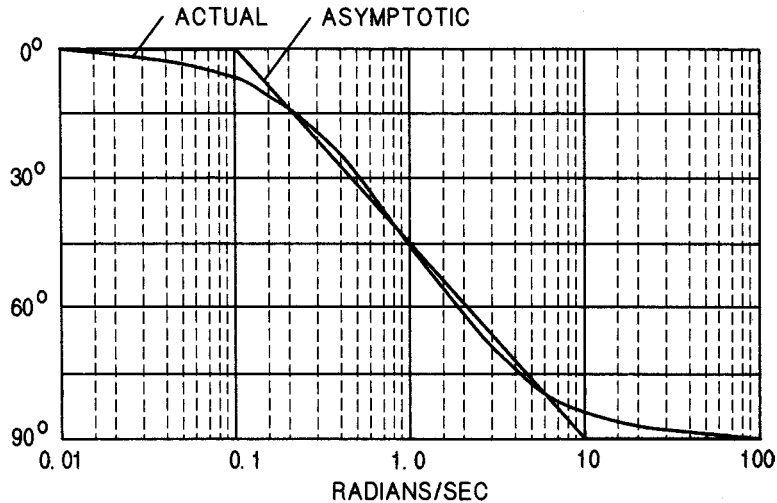

FIGURE 4.6 Phase responses of an R/C low-pass filter.

Filters are not the only sources of phase lag. Any sort of a time delay, termed a *transport lag*, also contributes to phase lag. In an SCR bridge converter, for example, an SCR cannot respond immediately to a command change unless it has a positive anode voltage. If the command is a sudden large decrease, the time delay may approach  $240^\circ$ , 11 ms in a 60-Hz system, if the previous SCR has just been fired. The average delay will be  $30^\circ$  for a small change in command, 1.4 ms. Phase shifts for such a 1.4-ms time delay are shown in Fig. 4.7.

Time delays also arise in sampled data systems. If the output of a system is periodically sampled for feedback, there is a potential transport lag of one sampling period and an average transport lag of one-half a sampling period before the information is available. In a complex system, these transport lags may become cumulative and constitute a source of instability.

#### 4.4. PID Regulators

Many industrial controllers employ a proportional, integral, differential regulator arrangement that can be tailored by the customer to opti-

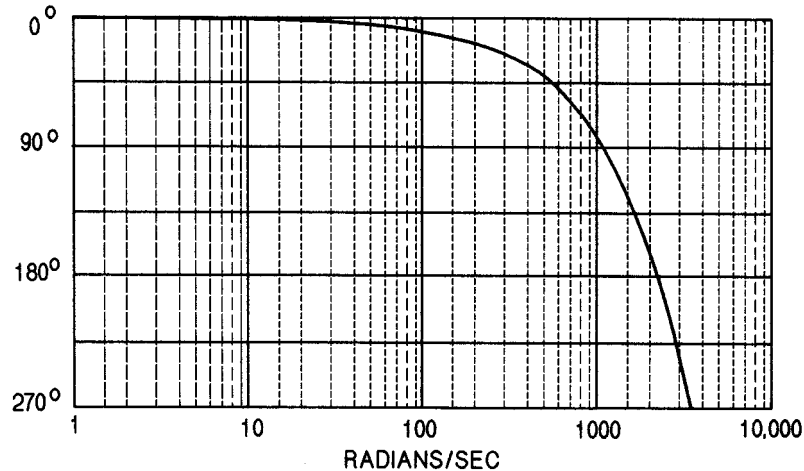

FIGURE 4.7 Phase lag of a 1.4-ms transport lag.

mize a particular control system. The basic layout is shown in Fig. 4.8. Three channels are summed with a variable gain on each. The system response can be varied over a wide range of characteristics. A system with only a proportional response has an error that is inversely proportional to that gain. If an integrator is added, the error can in principle be reduced to zero. The “in principle” must be added, because there are always limits on accuracy in any system. The differentiator can be used to compensate for lags in the system and to improve the high-frequency response and rise time. However, the differentiator amplifies noise, and there will be a limit to how much differential control can be added.

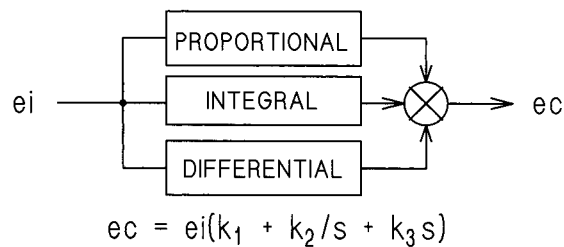

FIGURE 4.8 PID regulator.

### 4.5. Nested Control Loops

Many systems require nested control loops to control several variables. One example is a DC motor drive that must have a very fast current control loop to limit the armature current but also requires a voltage loop for speed control. The voltage control cannot override the current loop, but it will set the required current so long as it is within the limits set by the current loop. In short, the voltage or speed loop commands the current that is required to satisfy the voltage, but the current loop sets the current limit. Both loops must be unconditionally stable. Figure 4.9 shows a typical system. The armature current is regulated by feedback from a current shunt and isolator amplifier. The frequency of such a current regulator using SCRs can have a crossover as high as 1000 radians/sec, but 500 radians/sec is easier to handle and less critical on feedback. If the current loop is set up for 500 radians/sec, the voltage loop must, generally, crossover at a decade lower in frequency, 50 radians/sec, for stability on a 50- or 60-Hz system.

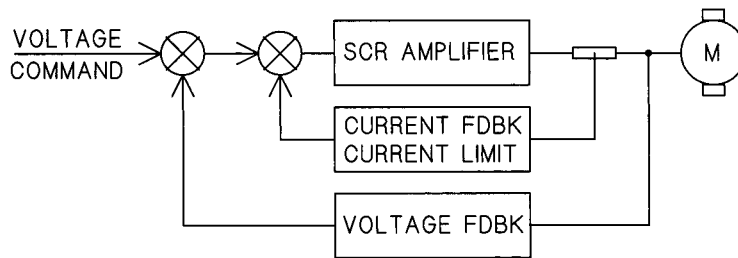

FIGURE 4.9 Nested control loops.

## Chapter 5

---

---

# Transients

Some aspects of transient voltages have been mentioned previously, but a more detailed examination will be made in this chapter. The long-term health of a power electronics system often hinges on its ability to withstand transient voltages arising both inside and outside of the equipment itself.

### 5.1. Line Disturbances

Lightning strikes and switching transients on power lines will propagate down the line and eventually arrive at a substation. There, the voltage will be clamped by lightning arresters to a level the substation equipment can handle without damage. This voltage will be passed on to the distribution lines in two forms: differential and common modes. The differential-mode voltage is the voltage between the power line conductors themselves, and it does not directly involve voltages to ground. The common-mode voltages are the voltages of the several conductors to ground.

Differential-mode voltages are passed directly through transformers and appear on the secondaries as transformed by the turns ratio. Some

attenuation may result from intrawinding capacitances, but interwinding capacitances may actually increase the voltage. Common-mode voltages are transferred to the secondary through the interwinding capacitances and can be effectively stopped by an electrostatic shield between the windings. Absent the shield, however, they can appear on the secondaries with a magnitude close to that on the primary. This can be a severe problem on medium-voltage systems where there is the possibility of 10 kV or more being developed on secondaries to ground.

The best protection from line-induced transients of all types on secondaries is a set of MOVs. Line-to-line MOVs on the secondary are best for differential-mode voltages, and line-to-ground MOVs will provide the best protection from common-mode voltages if a shield is not used. An electrostatic shield (Faraday screen) is a relatively low-cost addition to a transformer, and it is a good practice to specify a shield on transformers with medium-voltage primaries. With a shield, line-to-line MOVs are likely to provide sufficient transient protection. As mentioned in Chapter 3, dry-type transformers should be equipped with at least distribution-class lightning arresters on medium-voltage circuits.

## 5.2. Circuit Transients

Most gate drives for SCRs or insulated gate bipolar transistors (IGBTs) are supplied in one way or another through transformers with primaries at control circuit potential and secondaries at the cathode or emitter voltage, which may be far above ground. The transformers have interwinding capacitances that will couple the power voltage transients on the semiconductors to the low-voltage control circuits. Here, they may flow through printed circuit board traces and cause improper operation or even component failure. The best protection is to equip the gate drive transformers with electrostatic shields and to be sure their primaries are tied directly to ground whenever possible.



The use of multilayer PC boards has resulted in much lower-inductance ground planes than earlier traces could provide. Still, it is not wise to run grounds in on one end of a board and out on the other. Ground and common leads entering and exiting a PC board should be on the same end if possible, and the same is true for power leads.

The operating coils on contactors and power relays will generate transient voltages when they are deenergized. R/C snubbers on the coils will reduce the effect on other circuit elements, but it is good practice to separate low-power control signals from higher-power switching circuits by running them in separate wiring troughs. Power circuits should never be run in control or signal circuit troughs.

Signal circuits should be further protected by using shielded wire. The shields should be continuously connected, but they should be grounded only at a single point that serves as an earth ground for all signal commons. Figure 5.1 shows a problem that can arise with stray pickup, even with shielded wire. The shielded signal lead between boards A and B at top is run directly, while the control commons and signal shield are connected to a common ground point at a distance. This results in a large area that stray flux can penetrate and induce spurious voltages into the signal. If the signal lead is routed along the ground paths, the loop is eliminated. Shielding can eliminate electro-

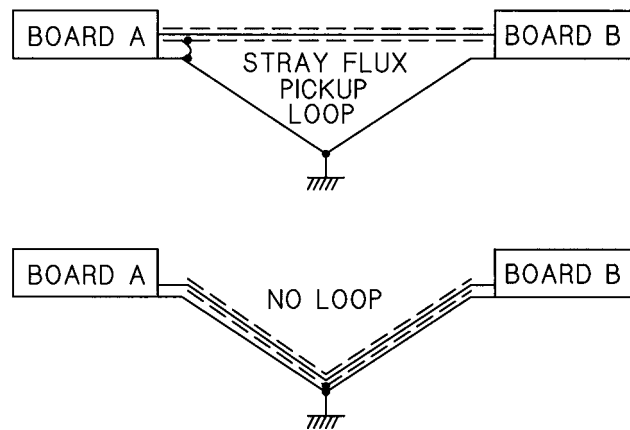

FIGURE 5.1 Signal wire routing.

static effects, but it does little to prevent electromagnetic couplings. Twisted pairs are the answer here.

Switching currents in semiconductors can cause very high  $di/dt$  levels, particularly in IGBTs, and these transients can couple to other circuitry. Gate drives and low-level circuitry should be kept away from power switching circuits.

The commutation period in SCRs will drop the source voltage to zero in a microsecond or so and hold it there until commutation is completed. The effect is called *notching*, and this disturbance can propagate to other equipment in the area through common power lines. One way to reduce this effect is to install R/C snubbers on the power lines. Such filtering is also useful to control the maximum  $dv/dt$  on SCRs from power line disturbances. Figure 5.2 shows a simple input circuit where the source inductance per phase is shown as  $L$ . The equivalent value for each R/C component as seen by a line-to-line transient is  $R_{eq} = 2R/3$  and  $C_{eq} = 3C/2$  for the capacitor. For an instantaneous line-to-line disturbance of  $V$ , the  $di/dt$  will be  $V/2L$ , and the maximum  $dv/dt$  passed on to the power electronics will be  $R_{eq}(di/dt)$ . For critical damping,  $C_{eq} = R_{eq}^2/8L$ . Any SCR turn-on current limit must also be observed in sizing such a filter.

Although most transients are associated with rising voltages, falling voltages can also interrupt operation. If a control transformer is supplying power to large contactor coils or fan motors, the inrush current may cause a voltage loss sufficient to drop relays or disrupt operations. The cure is to oversize the control transformer or use a low-leakage reactance design so that the control voltage can be held above the required minimum.

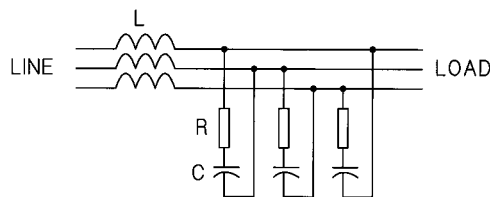

FIGURE 5.2 R/C notch reduction filter.

Signal processing electronic components, such as opamps, multipliers, digital processors, and the like, have a limited ability to reject common-mode noise on differential inputs. If noisy signals are expected, it is good practice to attenuate the noise before it arrives at the sensitive circuitry. Once inside, it is too late, and noise overloads can cause anomalies that are difficult to analyze. Figure 5.3 shows a multiplier chip as an example. The circuit is presumably immune to high-frequency noise because of the common-mode rejection of the multiplier. But if the noise level is not really known, it is a good idea to install a pole of rolloff ahead of each multiplier input. The pole should be located about a decade above the highest frequency that the multiplier is expected to pass.

### 5.3. Electromagnetic Interference

Electromagnetic interference (EMI) is a double-acting problem. Especially in military usage, equipments must not radiate interference beyond levels allowed by specifications nor be affected by defined levels of external interference. These levels are defined for both radiated and conducted levels. Radiated interference into and out of equipment can usually be thwarted by good grounding techniques and shielding of critical circuits. Interference conducted by supply, control, or load wiring may require the installation of low-pass traps such as shown in Fig. 5.4. A “T” section of this sort will reduce conducted noise in both directions, into and out of the equipment. Conducted noise will be revisited in Chapter 14.

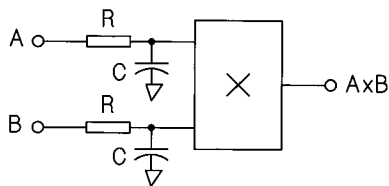

FIGURE 5.3 Multiplier input filtering.

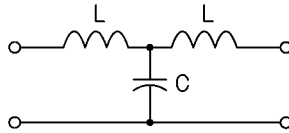

FIGURE 5.4 T-section filter.

Local EMI can cause problems with instrumentation. Shunts are often used to measure DC current levels and occasionally for AC. Isolation amplifiers are used to amplify the shunt output voltage that is usually in the 50 to 100 mV range. Difficulties may arise if care is not taken with the lead dress to the shunt, especially if the power circuit has a high ripple level. Figure 5.5 shows the nature of the problem. The lead dress at left provides a large loop that magnetic fields can penetrate and induce spurious voltages. At right, the leads have been twisted to minimize the loop.

Even with twisted leads, there is a less obvious loop caused by the thickness of the shunt itself. The shunt should be made such that the terminals are symmetric about the geometric center of the shunt, and this requires an even number of leaves and location of the terminals on opposite sides of the shunt body and opposite ends of the leaves. Figure 5.6 shows a recommended shunt construction that several vendors are willing to make at a small premium in price.

Even with these precautions, it is not always possible to eliminate all stray pickup in circuits with AC or high-ripple currents. However, contaminating signals can be neutralized with an air core pickup coil of a few turns connected in series with the shunt output. The location and orientation of the pickup coil must be determined experimentally.

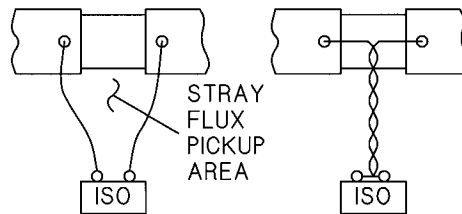

FIGURE 5.5 Shunt wiring.

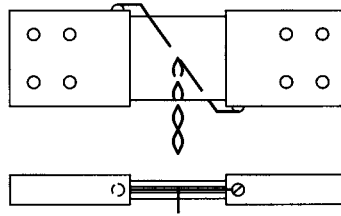

FIGURE 5.6 Preferred shunt construction.

The precautions on shunt metering apply also to oscilloscope measurements of low-level signals in the presence of interference. The ground lead of the scope should be looped back and forth along the probe to minimize the loop area and the resultant induced voltages.



## Chapter 6

---

---

# Traveling Waves

Traveling wave effects were once the nearly exclusive domain of communications engineers and electric utility transmission line engineers. However, as variable frequency, pulse width modulated (PWM) motor drives have gone to higher and higher PWM frequencies, standing-wave phenomena have appeared in motor circuits. Traveling waves are now of concern to many power electronics engineers, and an understanding of their effects is necessary for motor protection in installations with long cables or high PWM frequencies. In modern terms, a transmission line is any set of parallel or coaxial conductors of finite length, and they may be printed circuit conductors or miles of overhead wires.

### 6.1. Basics

Standing waves appear when a length of line is excited at a frequency for which the electrical line length is a significant part of an electrical wavelength. They result from the constructive and destructive interference of forward and reflected waves on the line. The behavior of the line can be determined by solving the applicable differential equations relating the line parameters to the exciting frequency. The solu-

tion of the equations for a line with losses is rather complex and adds little to the practical considerations, so the lossless line will be analyzed instead.

In the lossless line,  $L$  is the series inductance per unit length, and  $C$  is the shunt capacitance. If a differential length,  $dx$ , is considered, the inductance for that length is  $L dx$ , and the voltage in that length is  $e = -L dx(di/dt)$ . Since  $e = (de/dx)dx$ , the equation can be written as  $dx(de/dx) = -L dx(di/dt)$ . Similarly,  $dx(di/dx) = -C dx(de/dt)$ . Dividing out the  $dx$  terms and substituting partial derivatives, the fundamental forms of transmission line equations result:

$$-\partial e/\partial x = L\partial i/\partial t \text{ and } -\partial i/\partial x = C\partial e/\partial t$$

By differentiating with respect to  $x$  and then with respect to  $t$ , these equations can be solved simultaneously to yield second-order, elliptical, partial differential equations for both  $e$  and  $i$  individually with respect to  $t$  and  $x$ . The classical forms then result:

$$LC\partial^2 i/\partial t^2 - \partial^2 i/\partial x^2 = 0 \text{ and } LC\partial^2 e/\partial t^2 - \partial^2 e/\partial x^2 = 0$$

These equations can now be solved by transforms or classical methods. Explicit solutions can be developed with hyperbolic functions in the complex plane, and these solutions were the only practical means of line analysis until the digital computer was developed. Fortunately, the computer offers an easier method of analysis by numerical integration, and line losses can be incorporated with relative ease. The difference equations can be solved by simple Euler integration, so the whole process is not nearly as daunting as in earlier years.

The difference equations for differential sections of line are shown in Fig. 6.1. These equations allow numerical solutions for the voltages and currents on the line as functions of distance and time. Although it may not be immediately apparent, these difference equations, in the limit, replicate the differential equations.

Before proceeding to typical solutions, several derived parameters should be defined. First, the line has a surge, or characteristic, imped-



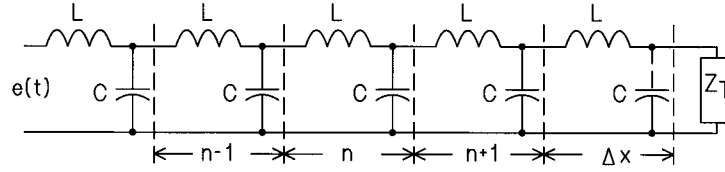

$$\Delta e(n) = (i(n) - i(n+1)) \cdot \Delta t / C \quad \text{and} \quad \Delta i(n) = (e(n-1) - e(n)) \cdot \Delta t / L$$

$$e(n) = e(n) + (i(n) - i(n+1)) \cdot \Delta t / C \quad \text{and} \quad i(n) = i(n) + (e(n-1) - e(n)) \cdot \Delta t / L$$

FIGURE 6.1 Transmission line difference equations.

ance defined as  $Z_0 = (L/C)^{1/2}$  and, second, a velocity of propagation  $v = 1/(LC)^{1/2}$ . The characteristic impedance defines the relationship between the line and its attached load, and the velocity of propagation defines the speed of signal transmission along the line and consequently its electrical length. The electrical length of the line, in terms of wavelengths for any given exciting frequency, is  $\lambda_p/\lambda_e = v/c$ , where  $\lambda_p$  is the physical line length,  $\lambda_e$  is the exciting frequency wavelength in free space,  $v$  is the velocity of propagation, and  $c$  is the speed of light. The parameters vary widely among the various types of transmission lines and cables typically encountered in power electronics. Figure 6.2 shows two examples of such lines.

The overhead line has a high series inductance and relatively low shunt capacitance that leads to a high surge impedance. It also has a

Overhead line of 1/0 conductors with 6-ft spacing:

$$Z_0 = 325 \, \Omega, \quad v = 83\%$$

Shielded coaxial cable, 15 kV with 500 kcm conductor:

$$Z_0 = 21 \, \Omega, \quad v = 29\%$$

Velocities are shown as percentages of  $c = 3 \times 10^8$  m/s

FIGURE 6.2 Transmission line parameters.

relatively high velocity of propagation because of the low capacitance. In the cable, things are reversed. Shielded cable has a very high capacitance that makes the surge impedance low, and the velocity of propagation is also low. Note that the physical wavelength of a signal in such shielded cable is less than one-third of the wavelength in free space.

## 6.2. Transient Effects

The problems that can arise from traveling waves in motor circuits can best be illustrated by examining the response of a transmission line to applied transient voltages. Figure 6.3 shows the extreme case of a transmission line with a zero source impedance and no load termination. The reflection coefficient,  $RC$ , is given by

$$RC = \frac{Z_T - Z_0}{Z_T + Z_0}$$

where  $Z_T$  is the terminating impedance and  $Z_0$  the surge impedance. This parameter defines the reflected waves that are generated with a given terminating impedance.  $RC = 1$  for the unterminated line.

When a traveling wave reaches the end of a line, a reflected wave will be developed unless the line is terminated in its surge impedance. If  $RC$  is positive, the reflected wave will be positive and will add to the incident wave. If  $RC$  is negative, the reflected wave is negative and subtracts from the incident wave. In the limiting cases of open and short circuit terminations, the open circuit termination doubles the incident voltage and the short circuit brings it to zero. In either case, however, the reflected wave continues in the reverse direction, and the incident wave continues, in effect, in the forward direction. The process is shown in Fig. 6.3 with a unit applied voltage. At any point on the line, the voltage is the sum of the incident and reflected waves.

The receiving end voltage will continue the sequence of +2, +2, 0, 0, +2... as long as the voltage is supplied at the sending end. The

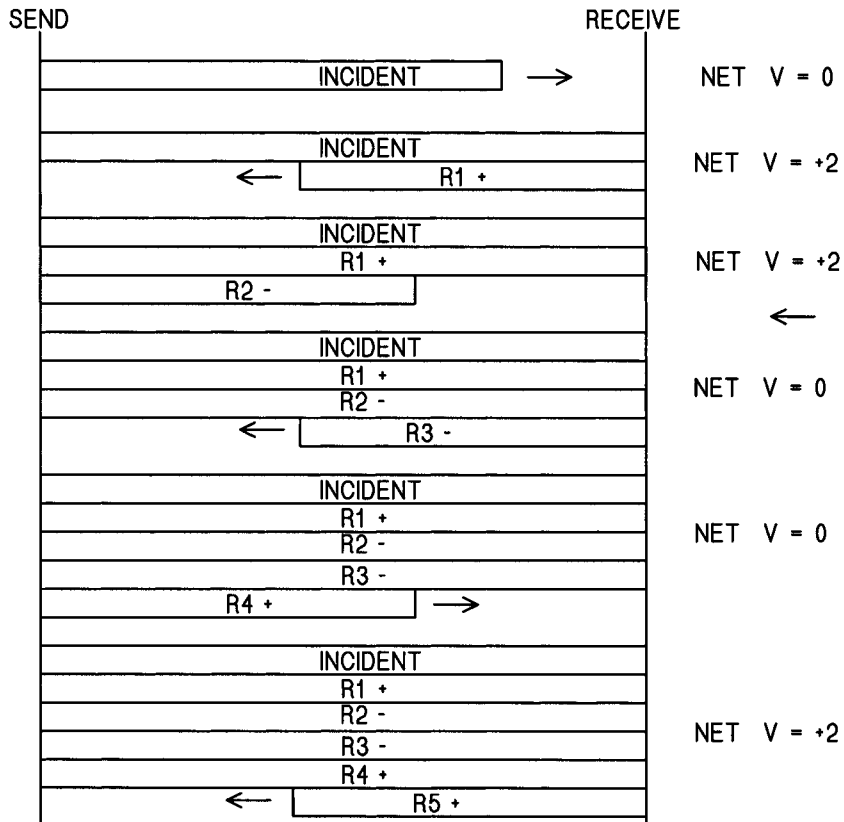

FIGURE 6.3 Transmission line reflections—open load.

sending end will continue to invert each reflected wave, and the receiving end will return it with the same polarity. Although this little exercise examined a lossless line with pure reflections, much the same process obtains with typical shielded cable or conductors in conduit.

Figure 6.4 shows the effects of shaping the voltage wavefront to reduce the rate of rise. A unit voltage wave with various rise times is applied and the receiving end voltage shown for each. Note that a rise time of more than about ten times the transit time,  $2 \mu\text{s}$  in this example, will nearly eliminate the overshoot. Such shaping can be done with low-pass filters on a drive output to protect a motor. Figure 6.5

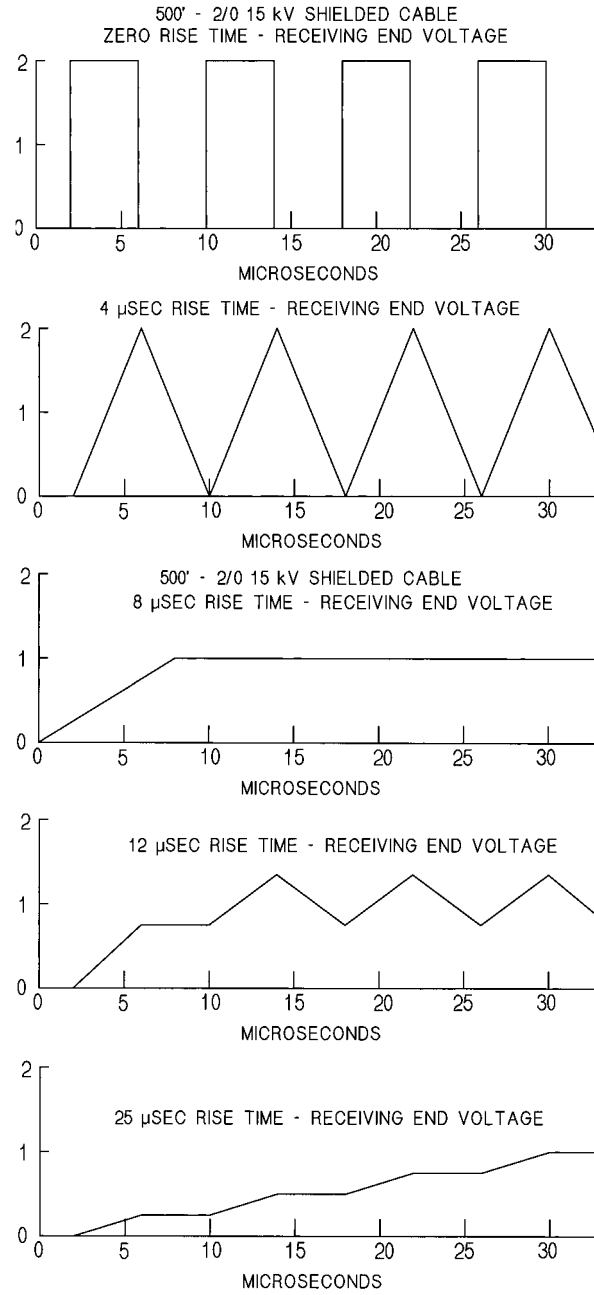

FIGURE 6.4 Front-of-wave shaping.

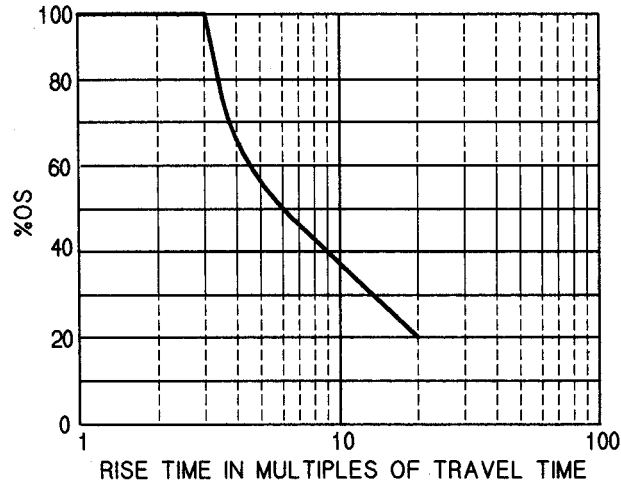

FIGURE 6.5 Overshoot as a function of rise time.

quantifies the needed shaping for a given overshoot. The curve is the maximum envelope of an oscillatory function.

When the exciting voltage is repetitive, there is theoretically no limit to the magnitude of voltage overshoot at the receiving end of a line. In reality, losses reduce the overshoot, but it can ratchet up well beyond what a single pulse can produce.

### 6.3. Mitigating Measures

Reducing the load voltage overshoot means reducing the slope of the wavefront at either the source end or at the load to control the reflected waves. In principle, it is possible to match the line impedance with a  $Z_0$  termination, but this is not often practical because of the unknown high-frequency characteristics of the load. The usual measures are to install an inductor or low-pass filter on the source. If an inductor alone is used, it should have an inductance on the order of five times the line inductance to the load. A low-pass filter should be simulated with the system on a computer to avoid possible resonance problems.

Installing a surge capacitor at the motor is valuable when the motor terminals are accessible to the drive designer. The capacitor will tend to reduce the end turn effects that can damage motor windings. However, the capacitor may need a series damping resistor and, again, a computer simulation is suggested.

## Chapter 7

---

---

# Transformers and Reactors

Transformers form a special class of components in power electronics. The design and performance of many systems are critically dependent on the design and performance of their associated transformers, and the transformer often forms the major cost item in the system. It will often pay in performance, reliability, and economy if the power electronics design engineer understands transformers and has a technical dialog with the transformer vendor. It is also a good idea to have the current IEEE C57 series of transformer standards available. These standards may be purchased from the publications department of the IEEE in a single, bound volume.

The author once served as an expert witness in a lawsuit in which a drive manufacturer sued a transformer vendor for transformers that failed in a foreign steel mill. The problem was caused by radial flux generating eddy currents in an electrostatic shield. The transformer had a full axial length primary and two axially stacked secondaries that conducted alternately. The shield overheated, the insulation failed, and the vendor was held responsible for a faulty design. Had the customer explained the service conditions to the vendor rather than relying on a standard specification, the problem might have been avoided.

### 7.1. Transformer Basics

A review of coupled circuit equations is a good starting point for a discussion of transformers, because it is wise to keep them in mind when examining transformer characteristics. First, we examine a simple pair of coupled coils. Figure 7.1 shows two coils in proximity with instantaneous voltages and currents as indicated.

The magnetic fields of these two coils have common regions, and the coils are therefore said to be *coupled*, and a coefficient of coupling,  $k$ , defines the degree of coupling. If the coils have inductances  $L_1$  and  $L_2$ , then a mutual inductance can be defined such that  $M = k(L_1L_2)^{1/2}$ . The equations for voltages and currents can now be written. For the two conditions of coil 2 open circuited and short circuited with coil 1 excited,

$$\begin{aligned} \text{o.c. } e_1 &= L_1 \frac{di_1}{dt} & \text{s.c. } e_1 &= L_1 \frac{di_1}{dt} - M \frac{di_2}{dt} \\ 0 &= -M \frac{di_1}{dt} + L_2 \frac{di_2}{dt} \end{aligned}$$

These can then be solved to yield  $L_{oc} = L_1$  and  $L_{sc} = L_1 - M^2/L_2$  where  $L_{oc}$  and  $L_{sc}$  are the open circuit and short circuit inductances, respectively. Then,

$$k = \sqrt{1 - \left(\frac{L_{sc}}{L_{oc}}\right)} = \sqrt{1 - \left(\frac{X_{sc}}{X_{oc}}\right)}$$

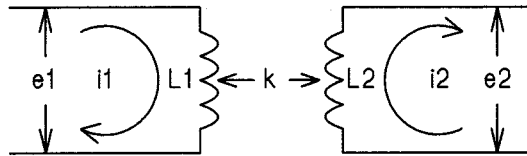

FIGURE 7.1 Coupled coils.



Figure 7.2 shows an equivalent circuit for an idealized transformer with no losses. From the equations for Fig. 7.1,  $L_{oc} = L_1$ ,  $L_{sc} = L_1 - M^2/L_2$ ,  $A = L_1 - M$ , and  $B = L_2 - M$ .  $A$  and  $B$  are defined as the primary and secondary leakage inductances, respectively, and  $M$  is the magnetizing inductance. More usually, the inductances are replaced by their reactances at the operating frequency. If the turns ratio is  $n:1$ , primary and secondary quantities are related by  $E_s = E_p/n$  and  $I_s = I_p \times n$ .

These quantities are often expressed in percentage or per unit quantities, since they can then be used to compare transformers across all ratings, designs, and leakages. The leakage reactance in percent is equal to the full-load voltage drop as a percent of rated voltage for that winding. Note that this is a vector voltage drop, and the effect of this drop on the terminal voltage will depend on the current phase angle. The exciting current is expressed as a fraction or percent of rated load current which, in turn, is rated voltage divided by the magnetizing reactance.

Considering a typical transformer with a total leakage reactance of 6% and an exciting current of 5%, equal to a magnetizing reactance of  $100/0.05$  or 2000%,

$$k = \left[ 1 - \left( \frac{6}{2000} \right) \right]^{1/2} = 0.9985$$

Thus, the typical iron-core transformer has a very high coefficient of coupling. Air-core coils, on the other hand, generally have much

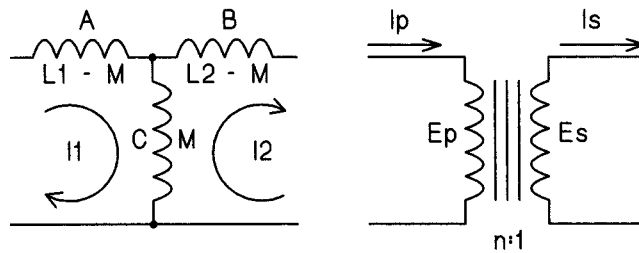

FIGURE 7.2 Ideal transformer.

lower coupling coefficients, and they must be wound bifilar or coaxial to achieve a high coupling factor. Some transformers designed for constant current output are built with an air gap that provides intermediate coupling coefficients.

In the real world, the ideal transformer is complicated by exciting current and leakage losses as shown in Fig. 7.3. Except for some very special types, nearly all transformers are made with laminated iron cores to maximize the coupling between the coils. Exciting current is the current required to produce the desired flux density in the iron plus the current due to hysteresis and eddy current losses in the iron. A typical exciting current will be in the range of 3 to 8% of rated primary load current, and total leakage reactances will produce a 3 to 10% voltage drop at full load. Again, this is a vector drop and will not directly subtract from secondary voltage except for the case of a nearly zero power factor lagging load. The exciting current and loss resistances are usually neglected in transformer regulation equations. Total losses vary widely but may be approximated as 0.25 to 1.0% of rated load for transformers from 1000 to 10,000 kVA. Larger transformers tend to have lower losses and smaller transformers higher losses than those indicated.

Primary and secondary leakage reactances can be transferred from one winding to the other by the equations  $XT_p = X_p + n^2 X_s$  and  $XT_s = X_s + X_p/n^2$  where  $XT_p$  and  $XT_s$  are the total leakage reactances in ohms, referred to the primary and secondary, respectively, with  $n$  the number of turns. When a transformer impedance is simply speci-

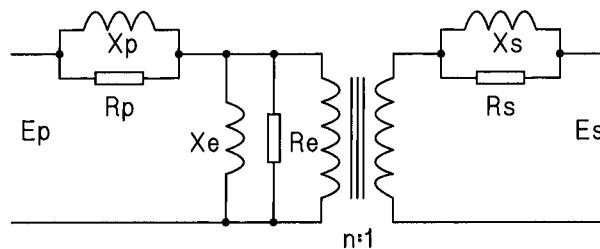

FIGURE 7.3 Typical transformer representation.

fied as  $Z\%$ , one may assume the impedance is reactive, and the secondary voltage drop at rated current will be  $Z\%$  or  $Zpu$  of rated voltage. If the transformer is faulted, the rms symmetrical fault current will be  $1/Zpu$  times rated current. For example, a transformer with 5% reactance, 0.05 pu, will have a symmetrical short circuit current of 20 times rated current, 20 pu. These numbers assume the source impedance is negligible.

Percent regulation in a transformer is defined as  $100(V_{NL} - V_{FL})/V_{FL}$  where  $V_{NL}$  and  $V_{FL}$  are the no-load and full-load voltages, respectively. Regulation can be determined from the phasor diagram shown in Fig. 7.4.

Power transformers intended for converters often are made with two secondaries, one delta connected and the other wye connected. The two secondary voltages are then  $30^\circ$  out of phase, and it is possible to greatly reduce some of the harmonic currents in the primary that result from the nonlinear secondary loading. The diagram is shown in Fig. 7.5.

The characteristics of this transformer can be determined on test. As typically used, the per unit reactances of  $S1$  and  $S2$  are equal. If the three windings are individually shorted one at a time with the other windings energized, the following equations result:

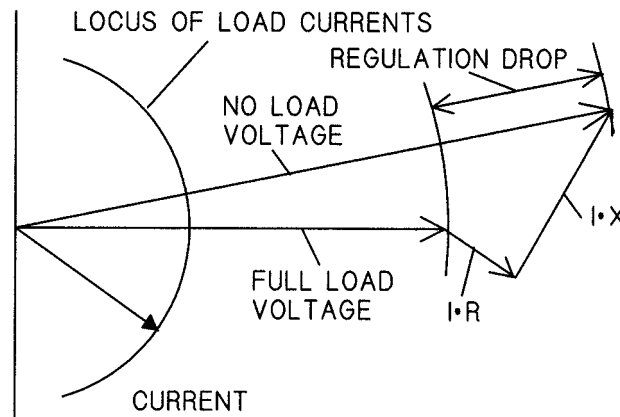

FIGURE 7.4 Transformer regulation phasor diagram.

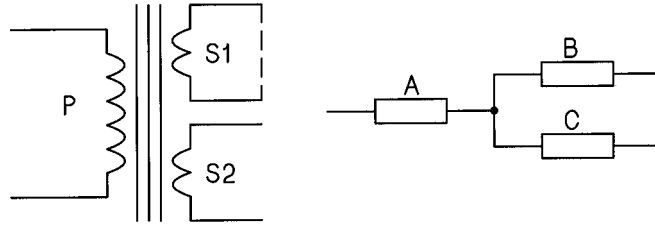

FIGURE 7.5 Three-winding transformer.

if  $P$  to  $S1 = X$ ,  $P$  to  $S2 = X$ ,  $S1$  to  $S2 = Y$

then,  $A + B = X$ ,  $A + C = X$ ,  $B + C = Y$

and  $A = X - Y/2$ ,  $B = Y/2$ ,  $C = Y/2$

If the secondaries are tightly coupled, then  $Y$  is very low, and the equivalent reactance is nearly all in the primary. If they are poorly coupled so that  $Y$  is high, the primary reactance,  $A$ , may go negative. If the secondaries have a particular coupling to each other, the primary reactance can be zero, and all the equivalent reactance is in the secondaries. A negative primary reactance implies a regulation characteristic in which the secondary voltage of a converter falls less under load, and this can be used to advantage to improve regulation. At the other end of the spectrum, loose coupling from the primary to the two secondaries can be used to reduce the short circuit current.

## 7.2. Construction

Two basic core and coil arrangements, shell form and core form, are used in transformers. Both are illustrated in Fig. 7.6 in single-phase versions. The shell form is appropriate for the largest and highest-voltage transformers. The windings are pancake coils that are stacked prior to assembly of the core. The coils are surrounded by core material except for the end turns, and they can be braced for

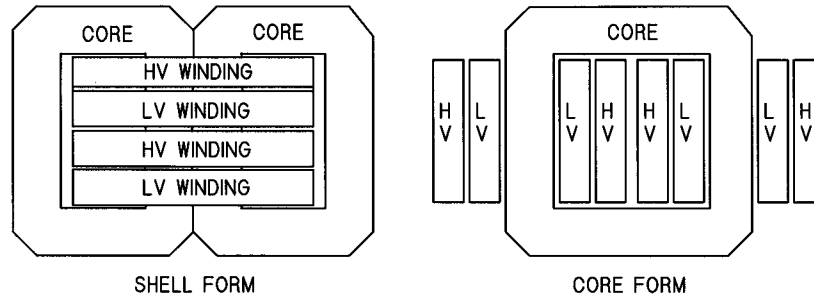

FIGURE 7.6 Transformer cross sections.

high fault currents and interleaved for low leakage reactance. Shell form transformers are almost invariably oil filled, and units as large as 500 MVA have been built for generator transformers.

The core form design places the coils over a vertical leg of laminations. The coils, in effect, surround the core. Coils are lathe wound with either circular or rectangular cross sections. This construction is appropriate for smaller transformers and to dry-type units. Core form construction in the 10 kVA to 20 MVA range is quite common. One fact that makes core form designs difficult in very large units is bracing for fault currents. Since force is proportional to the square of the current, a fault current of 20 times normal creates 400 times normal stresses. The coils are subject to large radial forces, and they have no bracing except for the circumferential coil wrapper. The inner winding tends to be compressed against the core on faults, while the outer winding heads for outer space. The core, or at least the core corners, may be covered with polyester fiberglass to protect the inner winding, and the outer winding may have a fiberglass wrap. There is also an axial force that must be retained by blocking the coil ends against the core. Nonetheless, the vast majority of medium-voltage and medium-power transformers are core form because of manufacturing economies.

Two variants on the core form transformer are worthy of mention. The coils may be cast in resin, often an epoxy, for environmental protection. If air cooling is used, a radial gap may be provided between

primary and secondary as a cooling duct. These transformers are usually relatively large for their ratings. Another technique relies on cast coils made with hollow conductors that are liquid cooled. Such direct liquid cooling has been extended to 15-kV class primaries in recent years, with deionized coolant used to control electrolysis. A propylene glycol and water mix is used for protection from freezing. Although the liquid-cooled transformers require demineralizer tanks, pumps, and heat exchangers, such items are often used with the higher-power semiconductors for direct cooling. The transformer, semiconductors, and bus work may share a common liquid cooling system. Such arrangements are especially suited to applications in which good quality cooling air may not be available. Examples are foundries, glass plants, metal mills, and the like where expensive filters and ductwork can be eliminated. Heat exchangers are either water-to-air or water-to-water and may be part of a larger plant system. One note of caution should be sounded on water cooling. If a glycol mix is used, the glycol must be chemical grade. Commercial antifreeze fluids have rust inhibitors and other additives that will increase the conductivity.

The general characteristics of oil-filled and dry-type transformers are summarized in Table 7.1. Oil-filled transformers employ mineral oil both as an insulation system and as a heat exchange medium. The typical insulation is pressboard or kraft paper, both of which are saturated by oil. The dielectric constants of these materials closely match the dielectric constant of the oil so that no electric field discontinuities are caused by the insulation. Hot oil is introduced into the heated windings under vacuum so that all entrained air is eliminated from both the oil and insulation. Heating the oil reduces its viscosity and facilitates penetration. The insulation is totally soaked by the oil, and the oil is relied on to eliminate air voids that would deteriorate the insulation from corona discharge. Furthermore, the dielectric properties of the oil mean that the internal spacings between components at different voltages can be much less than the spacings required in air. The operating temperature of the oil is limited by the gradual loss of its insulating qualities through the forma-

tion of hydrocarbon by-products. The process is accelerated by operation at elevated temperatures.

TABLE 7.1 Transformer Characteristics

<b>Oil-filled transformers</b>	<b>Dry-type transformers</b>
Unlimited voltage	Voltages to 34.5 kV
Pressboard insulation	Solid insulation
Welded tanks	Air or liquid cooled
Usually shell form	Usually core form
Maximum oil rise 65°C	Rises to 180°C or more
Hermetic bushings	Open terminals
External radiators	Vacuum varnish impregnation

Welded steel tanks are equipped with high-voltage bushings and low-voltage terminations, often in an air chamber. Tank design is arranged to minimize heating from stray flux. Bushings are generally rated about 2500 A maximum, and they are paralleled for higher currents. Radiators made from tubular steel fins are attached to the tanks of the larger oil-filled transformers, and oil is usually circulated by convection.

Dry-type transformers are the usual choice for indoor installations, although many are used outdoors. They can be built into equipment to reduce the overall size. They may be cooled by natural convection of air or forced cooled with fans. Many dry-type transformers are used within buildings to provide local 120/208-V service from a higher-voltage building distribution system. They are attractive for high-current applications because of the ease of providing terminations—no bushings are required.

Completed coil and core assemblies are heated and then subjected to a vacuum–pressure cycle to eliminate air bubbles. Coils are equipped with air ducts made from fiberglass *dog bones* or corrugated aluminum spacers. It is important that dry-type transformers be kept free from conductive contaminants or dust that will clog ventilation passages.

### 7.3. Insulation Systems

The insulation used between turns and between windings in a transformer is chosen to satisfy the service conditions of that transformer. Insulation life is related to the operating temperature, and standard temperature classes of insulation have been established for this purpose (see Table 7.2). At least two temperatures must be considered in insulation systems. There is an overall average temperature that can be determined by resistance rise of the conductors, and there are hot spots caused by uneven heat dissipation in the coils. Ratings for some standard insulation classes are shown as defined in ANSI C57 standards. All are based on a 40°C maximum ambient and a 24-hour average ambient of 30°C for distribution and power transformers.

TABLE 7.2 Insulation Classes

Insulation system class (°C)	Cooling system	Average winding rise by resistance (°C)	Hot spot rise (°C)
105 (Class A)	dry or oil	55	10
150 Class B)	dry only	80	30
185 (Class F)	dry only	115	30
220 (Class H)	dry only	150	30

Class 105° insulation is almost universal for transformers under 1 kVA and for oil-filled units. Insulation materials include kraft paper, cotton tape, enameled or Formvar wire, wood, pressboard in oil filled units, and similar low-temperature organics. Small oil-filled transformers are sometimes used for high-voltage service or other applications where the insulating qualities of oil are required. Transformers with the higher temperature insulation classes are usually smaller and lower in cost but have higher copper losses. However, the smaller frame of a high-temperature transformer may involve less magnetic material and lower core losses. There has been a gradual trend over the years toward higher operating temperatures as these insulations become less expensive and transformer size has become more important.



Class 150°C transformers may utilize Mylar<sup>®</sup> interlayer insulation, epoxy, and polyurethane-with-Nylon<sup>®</sup> wire coatings. Class 185°C systems may use Nomex<sup>®</sup> insulation, solderable polyester with epoxy (Polythermaleze<sup>®</sup>) or Isonel<sup>®</sup>, and Isomid<sup>®</sup> wire coatings with fiberglass and silicone construction materials. This is a popular compromise between efficiency and cost. Class 220°C is the highest-temperature insulation system in general use. Nomex<sup>®</sup> is used for interlayer insulation and polyimide for wire insulation. Fiberglass and silicone are used for construction materials. Still higher insulation systems are used in special applications, and these may involve mica layer insulation and ceramic wire coatings with no organic materials used.

Consistently overloading a transformer can result in serious damage to the insulation system. As an example, at 230°C, a particular synthetic insulation 0.01 inch thick will have a service life of  $10^5$  hours, whereas operating it at 320°C drops the life to only 400 hours. Lifetime is defined by the point at which the dielectric strength drops to only 300 V/mil.

Small single-phase transformers are often wound with a split bobbin as shown in Fig. 4.7. The molded bobbin provides excellent insulation and isolation between primary and secondary, a necessity when a label by Underwriter's Laboratories (UL) is needed. The UL specifications require that such a transformer is able to burn free in the event of a short circuit or primary failure without applying overvoltages to the secondary circuit or creating a fire hazard. Although most of these

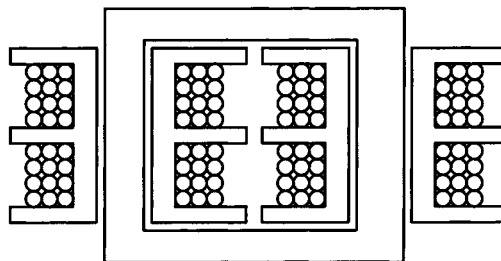

FIGURE 7.7 Split bobbin transformer.

transformers are rated for Class 105°C operation, the insulation is often Class 220°C so that isolation is maintained even when the primary or secondary burns. Many small transformers intended for printed circuit mounting are made this way.

As mentioned earlier, transformer insulation is treated to remove all bubbles and air pockets. The air has a lower dielectric constant than the insulation materials, so an air bubble will have a higher voltage gradient than the surrounding insulation. This gradient may be high enough to ionize the air and begin a corona discharge within the bubble. One result of this corona is the formation of ozone, a powerful oxidizing agent that can damage the adjacent insulation and result in ultimate failure. The same thing can happen from operating the insulation itself at too high a voltage stress. Two 6900-V, 3000-kVA dry-type transformers installed in a steel mill some years ago failed after only a month in service. The designer had used too little interlayer insulation, and corona destroyed it while it was still under warranty. The transformers had to be returned to the vendor for a rewind at his expense.

#### 7.4. Basic Insulation Level

The AC operating voltage of a transformer winding is shared equally by all the turns in the winding, and the turn-to-turn voltages are constant. Surge voltages, however, can create much higher turn-to-turn voltages at the exposed end of the winding due to capacitance distributions. Figure 7.8 shows an elementary five-section representation of these capacitances. The turn-to-turn and turn-to-ground capacitances are equal, and the inductance is large enough to be ignored. Note that nearly 62% of the incident surge voltage is taken up on the first turns. The turn-to-turn spacing and turn-to-turn insulation are sometimes increased at the HV end of windings in medium-voltage transformers, and grading shields are used to improve the surge voltage distributions.

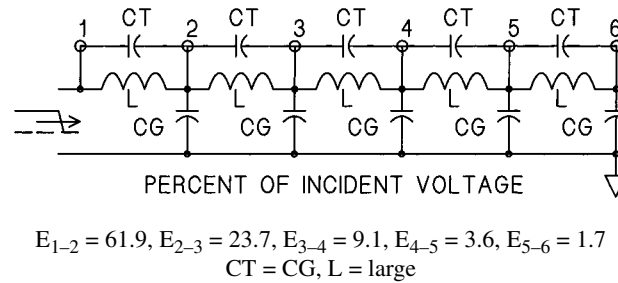

FIGURE 7.8 Surge voltage distribution in a transformer winding.

The ability of a transformer to withstand these surge voltages is described by the *basic insulation level (BIL)*, the peak voltage of a standard test pulse with a rise time to peak value of  $1.2 \mu\text{s}$  and then a decay to half value in  $50 \mu\text{s}$ . BIL voltages and sine wave test voltages are standardized for various voltage classes and types of transformers. These values are shown in IEEE C57.12.00 for oil-filled transformers and C57.12.51 for dry types.

## 7.5. Eddy Current Effects

Parasitic eddy currents in the windings and core can have a major effect on transformer losses, especially in high-current transformers and those with nonlinear loads. Figure 7.9 shows the path of these currents in a conductor. The magnetic field, shown as a plus sign, is normal to the length of the conductor, and it induces voltages that cause tiny loops of eddy currents to flow. The voltages in adjacent cells cancel along the centerline. But the net of these loops is a current that flows down the length of the conductor on one radial side and back on the other. The result is an increase in the  $I^2R$  losses, because there is an excess of current over the normal load current.

Transposing the conductor by making a half-twist in the middle of the length will reduce the net current, because the polarities of the induced voltages are opposite at the twist. High-current conductors are often made from two or three conductors arranged as a bifilar or

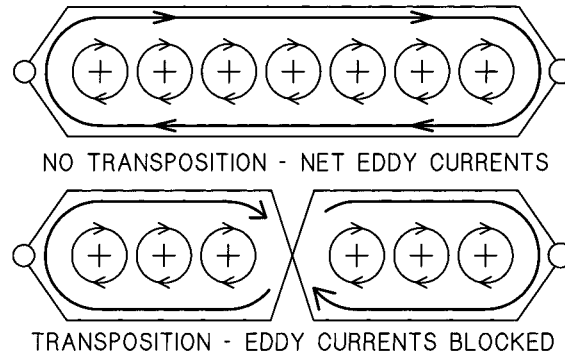

FIGURE 7.9 Transposition to reduce eddy currents.

trifilar set with transpositions. Eddy current losses are greatly reduced over a single large conductor of the same total cross section. Transpositions have been used since the earliest days of the telephone to reduce crosstalk and interference from power lines. Transpositions are often used on long transmission lines for phase balance.

Core iron is also a source of eddy current losses. In this case, the flux is in the plane of the laminations, but eddy currents will flow around the cross section shown in Fig. 4.10. These currents can be minimized by using thinner laminations, a common practice in high-frequency transformers. Practical considerations dictate a minimum gauge for cost and ease of handling, the most common magnetic material for power transformers being 0.014-inch thick silicon iron. Some highly specialized transformer laminations, however, are only 0.001 to 0.002 inches thick. They are rolled on precision Sendzimer mills and slit for toroidal cores on the type of slitters that were used for watch springs. Alloys may contain nickel and/or molybdenum.

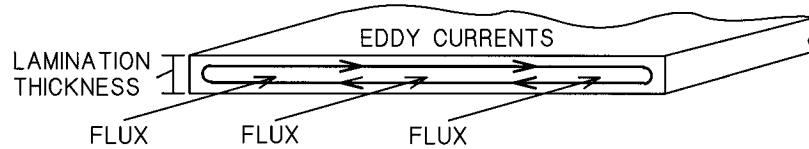

FIGURE 7.10 Eddy currents in lamination iron.

Losses from eddy currents can be increased considerably if the exciting voltage or the load current contains harmonics. In the voltage, the harmonics will increase eddy current heating in the core. In the current, they will increase conductor losses. The widespread use of variable-speed motor drives has meant that many modern transformers are expected to carry distorted current, and a standard rating technique has been developed to characterize the ability of a transformer design to tolerate harmonic currents. The harmonic capability of transformers is described by a factor  $k$  which is given by

$$k = \Sigma \left[ \left( \frac{I_n}{I_1} \right) n \right]^2$$

where  $n$  is the harmonic order, and  $I_n$  is the rms current at that harmonic including the fundamental. Standard designs are available at  $k = 4$  and  $k = 13$ . As an example, a current waveform containing 20% of fifth and 14% of seventh harmonic would have a  $K$  factor of  $K = [1 + (0.2 \times 5)^2 + (0.14 \times 7)^2] = 3$ . As long as the harmonics present are equal to  $1/f$  times the fundamental, the  $K$  factor will rise linearly with each harmonic. It is important to recognize that there is no sure way for the user to derate a standard transformer for use with nonlinear currents.

The flux level in a transformer increases from zero at the inner turns of the inner winding to a maximum at the outer turns of this winding and the inner turns of the outer winding, then again to zero at the outer turns of the outer winding. Figure 7.11 shows this effect. Induced voltages driving the eddy currents are proportional to the flux, and the loss is proportional to the square of the resultant current. Hence the losses are proportional to the square of the flux. Note that most of the losses occur near the gap between the two windings.

A grounded copper foil winding is often used between primary and secondary windings to eliminate transfer of common-mode disturbances from primary to secondary. These signals are present on both of the primary lines and are transferred to the secondary by the inter-

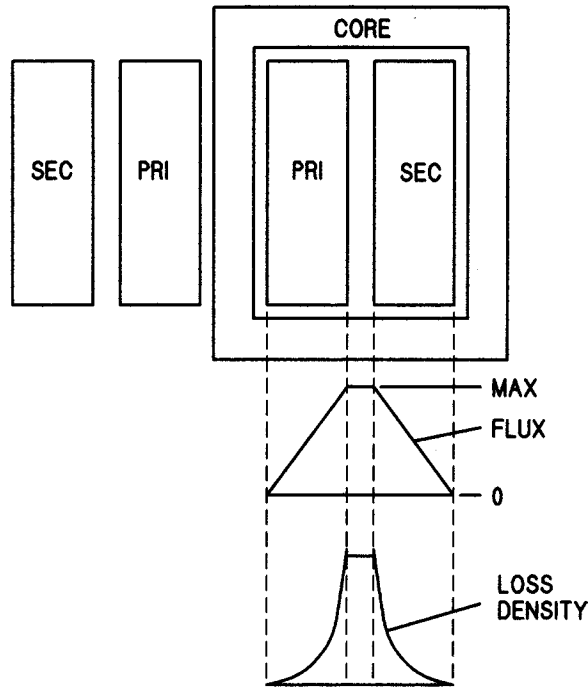

FIGURE 7.11 Eddy current losses in windings.

winding capacitance. The winding is referred to as an *electrostatic shield* or a *Faraday screen*. Such a shield can cause problems if the primary and secondary windings have different lengths in the axial direction or if axially arranged secondaries conduct at different times. In either event, some flux will pass radially through the shield and may overheat it, with the resultant loss of insulation integrity, a problem that was mentioned in the introduction to this chapter.

Earlier experience with this problem led the author to conduct a set of experiments to determine the response to flux normal to the plane of the sample by several different potential shield materials. A coil was coupled to the shield under test and excited with a chopped 60-Hz sinusoid. Sample temperatures were measured with a thermocouple. The results are shown in Fig. 7.12. A mesh screen is just about as effective for isolation as a sheet, and the resistivity does not matter

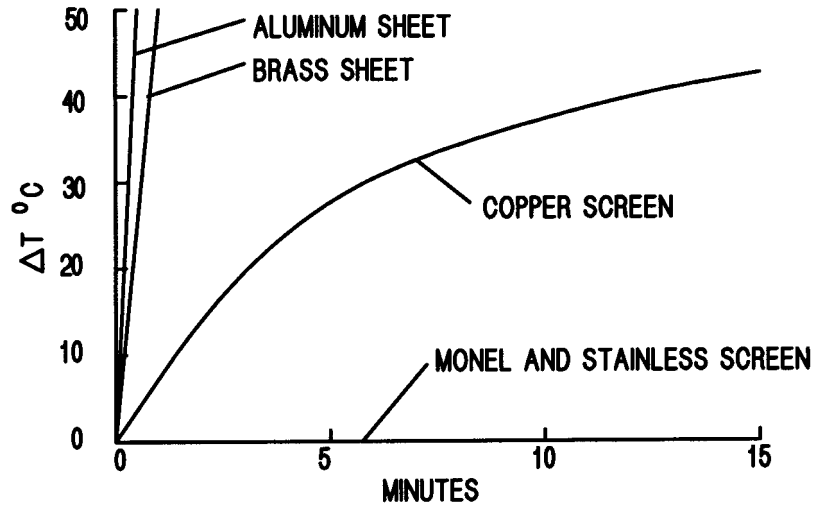

FIGURE 7.12 Eddy current heating in shield materials.

greatly for shielding from electrostatic effects, so this test led to the establishment of monel or stainless steel screen shields as standard for the author's company.

## 7.6. Interphase Transformers

Several precautions should be followed in specifying and using interphase transformers. The transformer must support the ripple voltage between the two half-wave sections of an SCR interphase converter circuit. But if the converter slews rapidly, the interphase must support a very much higher voltage during the transition. In an extreme case, the interphase transformer must support the entire line-to-line voltage from  $60^\circ$  to more than  $150^\circ$ . If it is designed to handle only ripple voltage, it will certainly saturate. One remedy is to limit the slew rate so that the transition is made over several cycles. The interphase transformer can also be gapped to saturate without damage, and a gap capable of supporting a DC unbalance of around 10% is a good safety feature.

The interphase transformer design should also be considered. Figure 7.13 shows two-leg and three-leg core constructions for an interphase transformer. The two-leg design has no magnetomotive force (MMF) balance and will spew a large amount of leakage flux that has the potential for heating the floor or walls of a cabinet. It is sometimes used because it requires less iron than a three-leg core design. The three-leg design has cancelling fluxes from the conductors and has a minimum leakage flux. The small cost difference is good insurance against field problems.

### 7.7. Transformer Connections

Autotransformer connections are often a convenient way to obtain odd voltages from standard transformers. Figure 7.14 shows how a 1-kVA stepdown transformer can be connected as an autotransformer with the secondary connected in a buck connection for 360-V output and in a boost connection for 600-V output. Note how high the circuit kVA capabilities are compared to the transformer rating. Several caveats should be noted in connection with autotransformers, though. First, the isolation between primary and secondary is lost. Second, the secondary is now at primary voltage above ground, and it may not be

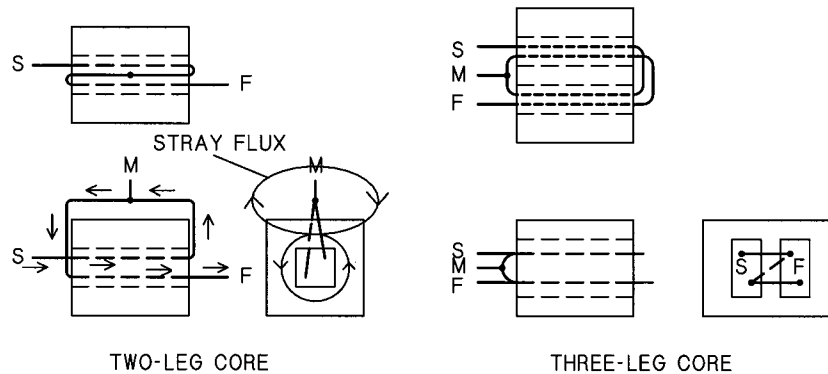

FIGURE 7.13 Two- and three-leg interphase transformer cores.



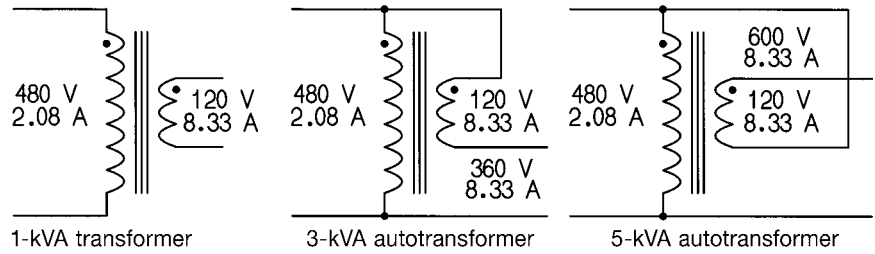

FIGURE 7.14 Autotransformer connections.

insulated for this voltage. In general, such connections will probably be safe for transformers rated to 600-V class, but the potential problems should be kept in mind.

Transformers are often equipped with primary taps for adjustment of the output voltage. It is generally easier and safer to bring out low-voltage than high-voltage taps on step-up transformers. When the primary turns are lowered by connecting to the lower-voltage tap, the secondary voltage increases over the nominal tap. Figure 7.15 shows the relationships with a constant primary voltage of 480 V. If the primary voltage is 5% low, connecting to the -5% tap will restore the secondary voltage to 4160 V.

Paralleling transformers is a common way of increasing the power capability over that of a single transformer. Some care should be exercised in paralleling to be sure one of them will not be overloaded. Figure 7.16 illustrates the sharing for two quite different transformers. They will share current in inverse proportion to their reactances as

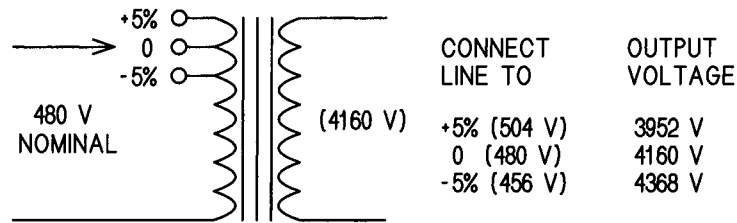

FIGURE 7.15 Transformer primary taps.

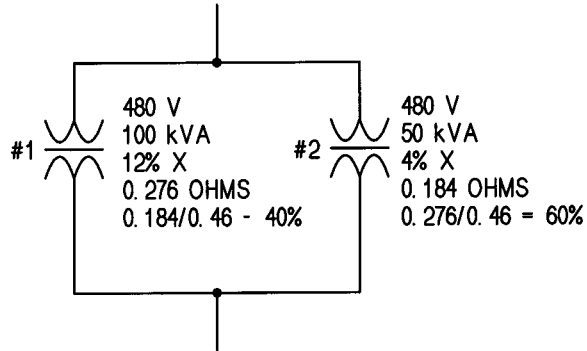

FIGURE 7.16 Paralleled transformers.

with paralleled resistors. Thus, the 100-kVA transformer takes up only 40% of the load because of its high reactance, while the 50-kVA transformer takes 60%. If the two are loaded at their combined rating of 150 kVA, the 50-kVA transformer will carry 90 kVA—nearly twice rated current.

A great number of different connections for three-phase transformers have been developed over the years. These are collected, named, and their electrical properties described in ANSI C34.2. All windings in a transformer must have the proper turns to generate the required terminal voltage and a conductor cross section rated for the current in that winding. When windings are combined to produce a phase-shifted output, however, the situation changes with regard to terminal voltage. The individual windings must be rated as above, but the terminal voltage with a phase shift is less than the algebraic sum of the two winding voltages. Hence, the useful kVA output from those windings is less than the sum of the individual winding kVA values. Figure 7.17 shows an arrangement used for 24-pulse rectifiers that require a set of 4 voltages  $15^\circ$  apart. Secondary 1 is a delta, secondary 2 an extended delta, secondary 3 a wye, and secondary 4 a wye zig-zag. Secondaries 2 and 4 carry a small penalty on kVA, and the transformer must be a slightly larger frame and rating than 1 with no phase shifting. Note that the  $30^\circ$  phase shift between the delta and wye comes with no kVA penalty.

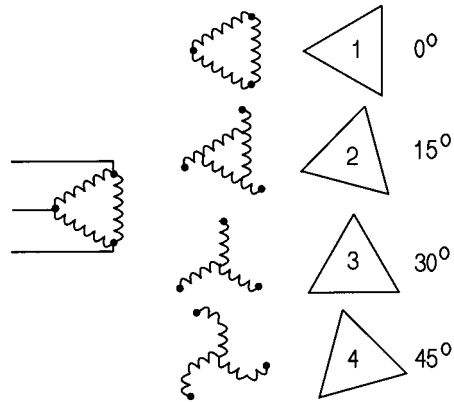

FIGURE 7.17 Phase-shifted secondaries, 24-pulse.

## 7.8. Reactors

Reactors of all types are the brethren of transformers. Iron-core reactors share the same characteristics as transformers as regards construction, insulation, and temperature ratings. Air-core coils are a more specialized class, often used in large sizes for outdoor harmonic filters or fault limiting, and in smaller sizes for  $di/dt$  limiting in equipment. Some general guidelines are shown in Table 7.3.

TABLE 7.3 Air-Core/Iron-Core Inductor Comparisons

Air core	Iron core
Linear inductance with current	Inductance may change with current
Generally high stray field	Stray field confined by core
Higher losses	Generally lower losses—higher “Q”
No core needed	Core material suitable for frequency
Larger for given $LI^2$	Smaller for given $LI^2$

The basic equations for an inductive circuit section are shown in Fig. 7.18. The voltage is the derivative of the flux linkages,  $\lambda$ , the product of inductance and current. If the circuit inductance is con-

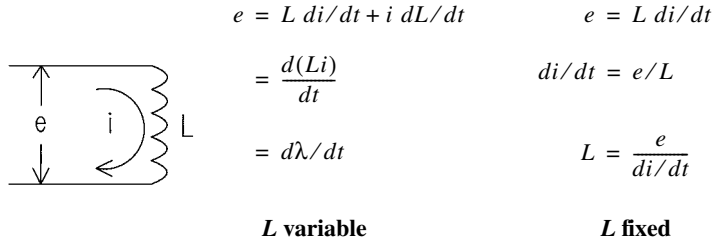

FIGURE 7.18 Basic equations for an inductive circuit.

stant, the equation becomes the familiar  $e = L di/dt$ . Less appreciated sometimes in this simple circuit are the two other forms yielding  $di/dt$  and  $L$  with a fixed inductance.

A simple equation for the inductance of a single-layer, air-core solenoid is shown in Fig. 4.19. The author came across this equation in a 1942 edition of a handbook he received as a high school graduation gift. The original source was the National Bureau of Standards, now the National Institute of Standards and Technology. It has served well for designing small radio-frequency coils as well as for estimating the inductance of various types of wirewound resistors. It is most accurate when the coil is long relative to its diameter.

Several other air-core coil configurations are described in this same source and may be of use to the reader. These are shown in Figs. 4.20, 4.21, and 4.22.

Another useful set of equations for inductance involves conductors. Fast-rising transient voltages can make conductors behave as a transmission line with traveling waves, a coupling inductance, or a voltage drop. The relationships in Table 7.4 will enable an analysis of inductances in a circuit.

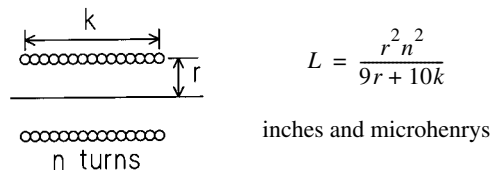

FIGURE 7.19 Inductance of a single-layer solenoid.

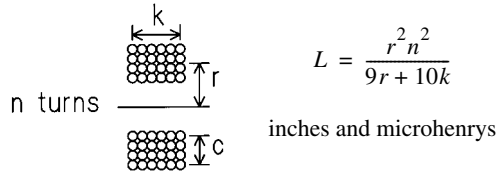

FIGURE 7.20 Inductance of a short, fat, multilayer coil.

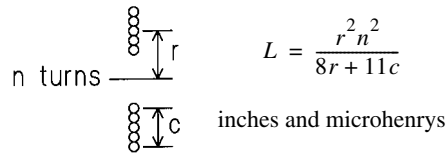

FIGURE 7.21 Inductance of a thin, flat, spiral coil.

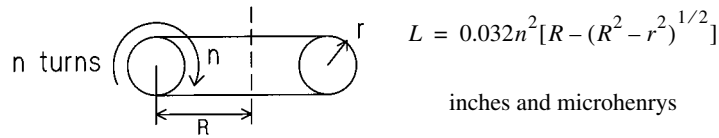

FIGURE 7.22 Inductance of a single-layer toroidal coil.

TABLE 7.4 Self and Mutual Inductances

Self-inductance of a single nonmagnetic conductor	
$L_s = 0.061 f \ln(f/GMR) + 0.017(GMR/f) + 2.18$	
Mutual inductance of two nonmagnetic conductors	
$L_m = 0.061 f \ln(2f/D) - 1 + D/f$	
where $L_s$ or $L_m$ = inductance in microhenrys	
$GMR$ = geometric mean radius of the conductor in inches	
$f$ = conductor length in feet	
$D$ = conductor spacing in feet	
<b>GMR of common shapes</b>	<b>GMR</b>
Thin round tube of diameter $d$	$0.5d$
Solid round bar of diameter $d$	$0.39d$
Rectangular bar, $a$ by $b$ section	$0.22(a + b)$
Round wires, $d$ diameter, $D$ spacing	$0.63(dD)^{1/2}$
The inductance of a go-and-return path, where the conductors are carrying the same current in opposite directions, is $L = 2(L_s - L_m)$ .	

Iron-core inductors take many forms, one general type of which is shown in Fig. 7.23. The coil is usually wound over the gap to minimize the stray field, but it has been separated for clarity in the sketch. The formula shown includes a 0.95 factor on the equivalent gap to account for fringing, flux that passes through the air instead of directly across the gap. This formula is useful as a quick design estimate. The flux density in the gap is given by  $B_{GAP} = 0.4 N I/G$  in gauss. A maximum flux density of 8 to 10 kG at peak current is typical for good linearity with the usual core materials.

The inductance of a three-phase reactor can be determined by a single-phase measurement. If the reactor is wired as shown in Fig. 7.24 with two phases in opposition, the three-phase inductance per phase is simply  $L = E/\omega I$ .

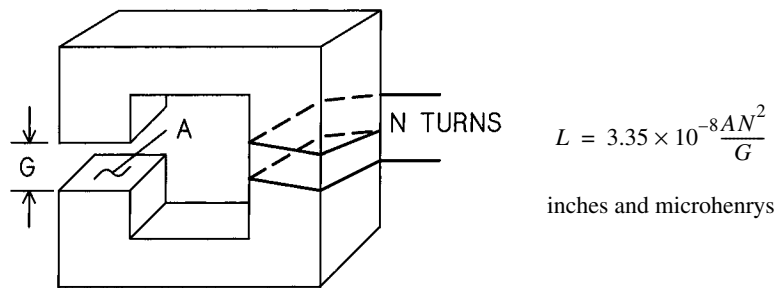

FIGURE 7.23 Elementary iron-core conductor.

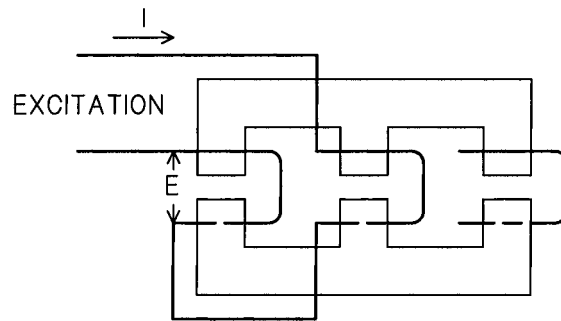

FIGURE 7.24 Three-phase inductance measurement.

## 7.9. Units

Sooner or later, in any text on magnetics, the subject of units of measurement must be considered. The author regrets having to introduce the matter, because three different systems of units are in general use. Physicists may prefer CGS units, engineers in general use MKS units, and transformer designers use English units. The international standard (SI) is the MKS system, and usage trends toward this system. Table 7.5 summarizes the present situation in magnetics units, and this table may serve either as a handy reference for the reader or a page to be torn out to line the bird cage.

TABLE 7.5 Magnetic Units

	MKS (SI) Units	CGS Units	English Units
Flux density	$B = \mu_r \mu_o H$	$B = \mu_r H$	$B = \mu_r \mu_o H$
Flux	$\phi = AB$	$\phi = AB$	$\phi = AB$
Faraday's Law	$v = Nd\phi/dt$	$v = 10^{-8} Nd\phi/dt$	$v = 10^{-8} Nd\phi/dt$
$\mu_o$	$4\pi \times 10^{-7}$	1.0	3.192
Units	A in $m^2$	A in $cm^2$	A in $in^2$
	B in teslas	B in gauss	B in lines/ $in^2$
	H in amp turns/m	H in oersteds	H in amp turns/in
	$\phi$ in webers	$\phi$ in maxwells	$\phi$ in lines
	F in amp turns	F in gilberts	F in amp turns

## 7.10. Cooling

Oil filled transformers can generally take care of themselves, since they are seldom built into other enclosures. Dry types, however, are often purchased as core and coils with no enclosure and built into equipment. The burden then falls on the equipment designer to provide adequate cooling for the transformer. When the transformer is purchased with integral fans, these are usually located at the bottom of the assembly, and they direct cooling air up through the coils. The only further requirement is to provide sufficient makeup air for cooling.

Transformers that rely on forced air from an external source or are convection cooled may require some attention to airflow. If no air is admitted to the enclosure, the internal air will become heated as it rises through the coils and will tend to stratify with the hot air accumulating at the top of the compartment. The only heat exchange is then by radiation and convection from the enclosure, so the obvious thing to do is to admit air at the bottom of the enclosure and exhaust it at the top. But this may not end the matter. The coils represent a high head loss to airflow, whereas the surrounding space offers little. Cooling air that enters the bottom vent may simply flow directly up to the top vent, bypassing the coils in the process. Figure 4.25 illustrates the solution of adding a horizontal skirt to force the cooling air up through the coils. The skirt can be made of lightweight insulating material such as polyester fiberglass sheet.

### 7.11. Instrument Transformers

AC voltages and currents that are too high for direct connection to meters or protective relays can be measured with the aid of voltage

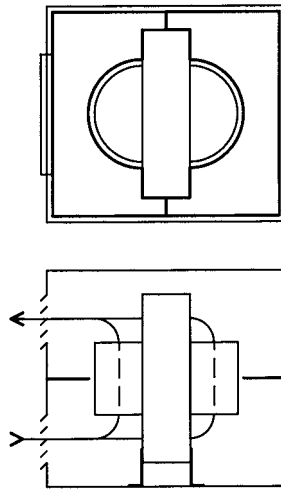

FIGURE 7.25 Skirting to improve transformer cooling.



(potential) and current transformers. Voltage transformers are transformers with low exciting current and leakage reactance that are insulated for high voltage on the primary. The usual secondary voltage is 120 V. These transformers are made with both single-insulator primaries for measuring line-to-ground voltages and double-insulator primaries for line-to-line metering. The transformer frame should be solidly earth grounded for safety on either type. Single-insulator transformers can be fused with only one fuse on the high-voltage side, but double-insulator transformers must be fused on both primary connections to protect against a ground fault in the primary winding. Medium-voltage fuses, specially rated for voltage transformers, are available. Since the primary fuses must be large enough to withstand inrush currents, they only serve as short-circuit protection. The transformer should be thermally protected by a secondary fuse and have one side of the secondary earth grounded for safety.

Current transformers are available in both wound primary and bushing types. The wound primaries are like an ordinary transformer with a few primary turns and a large number of secondary turns so that a large primary current is transformed into a small secondary current, the secondary being short circuited by the connected ammeter or relay. This type is used mostly for low currents or high-accuracy applications.

Bushing transformers are toroidal cores with a wound secondary, the winding operation being analogous to gift wrapping a doughnut. The primary “winding” is supplied by a high-current conductor that is run through the opening in the toroid and insulated by air spacing from the secondary. The usual secondary current rating is 5 A. The secondary of any current transformer must always be connected to a low-impedance load because, if opened while the primary is carrying current, very high voltages can be produced. One side of the secondary should be earth grounded for safety.

Instrument transformers can generally be trusted to yield reasonable harmonic response to 3 to 5 kHz, so they can yield good waveforms at power frequencies. Along with instrument transformers, another use-

ful current measurement tool is the Rogowski coil. This consists of a 360° single-layer toroidal winding on a nonmagnetic core. The conductor at the finish of the winding is brought back to the start, so that there is no net circumferential turn. The coil should be electrostatically shielded such that the shield material does not form a closed loop around the turns. Output voltage is proportional to the circuit  $di/dt$ . A low-pass filter or a gated integrator is used to recover the current signal.

Some Rogowski coils are wound in the form of a long, thin solenoidal winding, the end of which is bent back along the coil to the start. The far end is equipped with a disconnect coupling that allows it to be plugged in mechanically near the start. The coil can be wrapped around a high-current bus for measurements and the coupling then made. Such a coil is much smaller than a current transformer and easy to install. Like the current transformer, however, it cannot measure DC components.

Yet another device for current measurements is the Hall-effect transducer, a form of DC current transformer. This consists of a laminated iron yoke with a Hall-effect wafer in an air gap with the bus passing through the center of the yoke. The Hall-effect element generates a small DC voltage from flux normal to the wafer and an exciting voltage at right angles to the output voltage electrodes. These transducers can be very accurate, but they may be subject to interference from stray flux and the positions of the entry and exit buses in high-current applications. Some use flux balance from an external current source.

High-voltage transmission line metering is sometimes done with optics. Certain crystals have the property of changing the polarization axis of polarized light when subjected to a magnetic field. The change in angle can be measured and calibrated in terms of the current that produced the field. Other optical effects can be created by voltage stress on different crystals. These optical metering techniques enable high-voltage metering with complete electrical isolation.

## Chapter 8

---

---

# Rotating Machines

*Rotating machines* covers the whole spectrum of generators and motors of all types. They span the range from fractional horsepower motors to 1500-MVA generators with the family characteristic of a rotating shaft from which mechanical power is extracted or into which mechanical power is supplied. This chapter will examine some of the common characteristics of both generators and motors as they concern power electronics.

In these days, most prime movers for generators are rather nondescript turbines of one sort or another—combustion, steam, or hydraulic, or even wind. The author was fortunate enough to have seen reciprocating steam engines powering generators. In a memorable field trip by the YMCA in Minneapolis to a local factory, the group saw a large Corliss steam engine in operation, replete with a polished brass flyball governor, a huge flywheel painted bright red, and a melange of awesome mechanical motions. It made a lasting impression on a ten-year old visitor.

### 8.1. Direct Current Machines

DC motors and generators were the earliest entries in the transformation of industry from steam to electric power. This machine type con-

sists of a stationary set of windings that provide a magnetic flux and a rotating set of armature windings that turn within this field. A commutator with brushes on the rotating windings maintains the torque in a constant direction with rotation. The torque produced is proportional to the flux, and the speed is inversely proportional to the flux. At constant field current, the speed is proportional to the armature voltage.

DC machines can be operated with full field current and variable armature voltage to control speed. Constant torque is available in this mode. At full speed, the field current can be weakened and a regime entered wherein the available torque is proportional to the field current and the speed is inversely proportional to the field current. DC motors in mill and traction service are routinely operated with 3:1 field weakening for high-speed operation. Figure 8.1 shows the characteristic. They can supply high accelerating torques to their loads with full field current and then operate at high speeds with light load characteristics that made them ideal for transit applications. These motors and their DC adjustable voltage drives are gradually being replaced by induction motors with variable-frequency drives. The major advantage of the induction motor is the fact that it has no brushes and can be environmentally sealed.

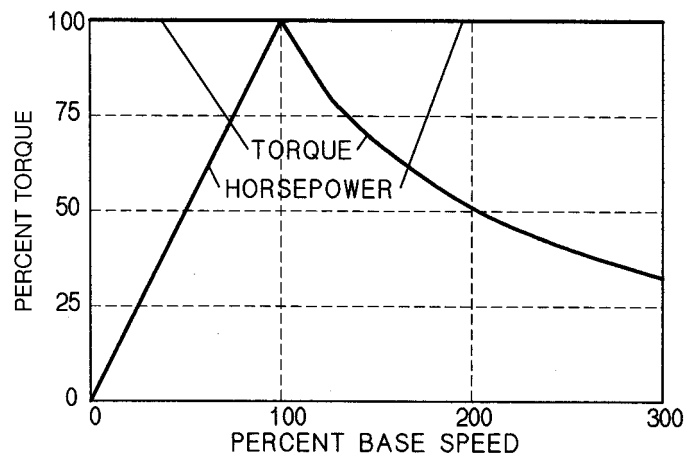

FIGURE 8.1 DC motor characteristics.

Drives for DC machines generally follow the simplified block diagram shown in Fig. 8.2. An inner current regulator loop is surrounded by a voltage or speed regulator loop. The inner loop is necessary because the DC machine appears as a very low resistance to dynamic voltage changes. The voltage feedback loop may be augmented by feedback from a tachometer or shaft encoder for precise speed control. The current regulator may be embellished with current ramps, current limits, and thermal limits for optimum motor performance and protection. A variable field supply may be added for extended speed.

The author once extended the company line of DC motor drives from 200 hp to 800 hp for an additional drive stand in an Oklahoma merchant steel mill. By customer request, the drive was built on a large, open panel for easy access and featured two identical converters, each of which could operate separately at half power.

## 8.2. Synchronous Machines

Probably the simplest and most basic of electrical machines is the synchronous motor or generator. In a generator, a rotating magnetic field is derived from a DC excited rotor winding. This rotating field couples to a set of windings on the stator and induces an AC voltage into these windings. The stator windings are arranged so that the rotating field generates a sinusoidal voltage, or a set of three symmetrical

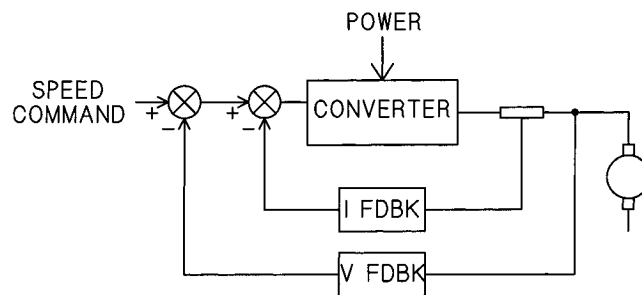

FIGURE 8.2 DC motor control.

sinusoidal voltages in a three-phase machine. The process is reversed in a motor with the stator windings being excited by a three-phase supply and the rotor supplying torque to a load.

The phasor diagram for a cylindrical rotor synchronous machine is shown in Fig. 8.3. This diagram neglects stator resistance, but this resistance is of little concern in most power electronics work. The variables are as follows:

- $i$  = armature current
- $e_t$  = terminal voltage
- $e_i$  = internal voltage
- $X_d$  = direct axis reactance
- $X_q$  = quadrature axis reactance
- $i_d$  = direct axis component of armature current
- $i_q$  = quadrature axis component of armature current
- $\theta$  = power factor angle
- $\delta$  = internal angle of rotor

The reactances,  $X_d$  and  $X_q$ , are the result of leakages and mutual inductances to damper windings as affected by the angle of the rotor relative to a phase winding. This phasor diagram describes the machine under steady-state conditions.

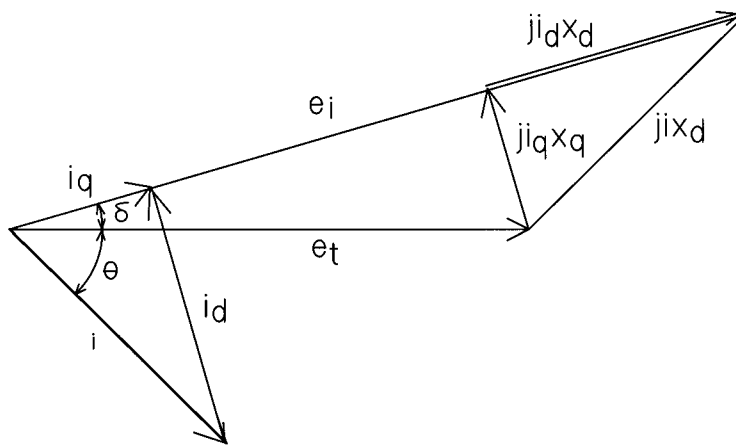

FIGURE 8.3 Generator phasor diagram.

When a generator is short circuited on the stator terminals, the current starts at a much higher value than the steady-state reactances would predict. At the moment of short circuit, flux is trapped in the leakage reactances of the windings, and conservation of the flux linkages across the instant the short circuit is created implies a much lower reactance. The initial reactance is termed the subtransient reactance and applies to both the direct and quadrature axes, thus creating  $X_d''$  and  $X_q''$ . Later, the flux changes, the current decreases and the characteristics are defined by the transient reactances,  $X_d'$  and  $X_q'$ . Finally, the current decreases to a value determined by the synchronous reactance,  $X_d$ . In addition to these AC components, there is a DC offset current that decays exponentially. The peak current can approach  $2\sqrt{2}$  times the rms subtransient sinusoidal current, and the maximum half-cycle rms current is given by  $\sqrt{3} E_{\text{rated}}/X_d''$ . However, a factor of 1.6 rather than 1.732 is typically used for circuit breaker coordination in consideration of the rapid current decrement.

The subtransient reactances are of major importance to power electronics design. A rectifier or converter operating from the terminals of a synchronous generator must transfer the load current from phase to phase in sequence. This process of commutation is described in later chapters, but for the moment it is sufficient to say that it subjects the generator to repetitive single-phase short circuits, each for a number of electrical degrees. Hence, the source reactance for commutation is a subtransient quantity and is usually represented by the average of  $X_d''$  and  $X_q''$ . Technically, the voltage driving commutations should be the voltage behind the subtransient reactance. In practice, however, this voltage rise above terminal voltage is relatively small, and the terminal voltage can be used for most calculations of converter performance. The greatest errors will occur at high currents and high angles of phaseback where the power factor approaches zero.

The position of the rotor relative to the stator flux in a synchronous machine will vary with the load, either electrical or mechanical. Figure 8.4 shows the process for generators and motors. In the generator, the torque applied to the shaft must be increased as the load power

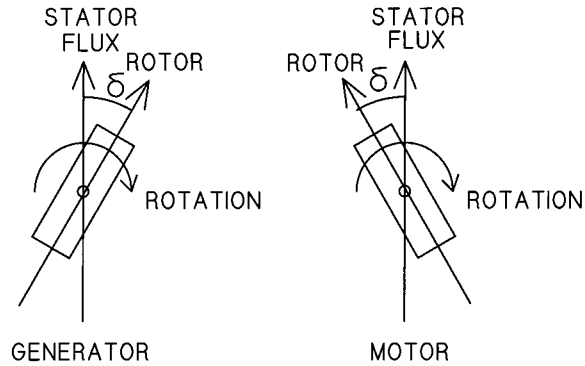

FIGURE 8.4 Generator and motor torque angles.

increases. This causes the rotor to develop a greater lead angle,  $\delta$ , from the stator. In the motor, the process is reversed, and the rotor lags the stator with an increasing angle as load torque is increased. The limit for this angle is 90 electrical degrees in either machine. Exceeding this load limit will cause the machine to slip a pole, and the rotor will no longer rotate in synchronism with the stator flux. This will allow continuous pole slipping with the potential for serious damage to the machine. Typical causes for such a problem are faults on a generator or overload torques on a motor.

Starting a synchronous generator merely requires bringing the machine up to speed with the prime mover, applying field current for rated voltage, and then connecting to a load or synchronizing the machine to an energized bus. Starting a synchronous motor is a bit more complicated. Most synchronous motors are equipped with auxiliary stator windings, known as *dampers*, that prevent oscillations from load torque changes and permit the motor to be started as an induction machine without field current. Larger motors are often started at reduced voltage with an autotransformer or SCR starter so as to keep the current magnitude under reasonable control. Field is then applied when the motor nears synchronous speed. If the motor is to be run from a variable-frequency drive, the drive can be started at zero frequency with full field. The motor will then come up to the set speed in synchronism with the drive frequency. The more sophisticated drives



will search out the initial rotor position by applying a small field excitation and observing the induced voltages in the stator phase windings. The drive phase can then be adjusted so that there is no torque transient or reverse rotation on starting.

Modern variable-frequency drives have enabled synchronous motors to replace many of the large DC machines used in steel mills for rapid reversing because of their ability to provide transient torques of several times rated value. The drive must be able to determine the torque angle and maintain a safe margin from pole slipping.

### 8.3. Induction (Asynchronous) Machines

The stator winding for an induction machine looks like the stator winding on a synchronous machine. However, instead of an externally energized field winding, the induction machine has a rotor with, typically, copper or aluminum axial bars embedded in magnetic laminations at the outer periphery of the rotor. By energizing the stator windings with multiphase current, a rotating flux is created, just as in the synchronous motor. This flux induces currents in the rotor bars and creates a torque reaction. The rotor must rotate at an electrical speed lower or higher than that of the stator to produce the eddy currents and torque. If the rotor speed is lower, it will produce shaft torque to a load. If torque is applied to the shaft in the direction of rotation, the motor can operate at a rotor frequency higher than synchronous and deliver electrical power from the stator. The difference between shaft speed and synchronous speed is known as *slip* and is usually expressed as a percent or per unit of synchronous speed. The induction motor can be operated as an induction generator with no external power if the excitation that provides the rotational flux is supplied from a capacitor bank on the stator. The machine will usually build up voltage self-excited from residual flux. However, it may be necessary to flash a voltage on the stator to start the process. The capacitance can be adjusted to operate the machine at rated voltage.

Figure 8.5 shows the equivalent circuit for the induction machine.  $X_s$ ,  $X_r$ ,  $R_s$ , and  $R_r$  represent the reactances and resistances of the stator and rotor respectively.  $X_m$  is the exciting reactance, and all reactances are at the supply frequency. The resistance  $R_r(1 - s)/s$  represents an equivalent load resistance as seen by the motor. With all constants in per unit terms, the torque producing power in the rotor circuit is  $P_r = I_r^2 R_r(1 - s)/s$ , and the shaft torque is  $T = I_r^2 R_r/s$ . Unit torque, 1.0 pu, is  $33,000 \times \text{hp}/(2\pi \text{ rpm})$ . Units are lb-ft of torque, rated hp, and rated rpm at full load. For most computational purposes, the exciting branch can be neglected.

Figure 8.6 shows speed/torque/current curves for a typical induction motor started across the line. Point 1 shows the locked rotor torque, point 2 the pull-up torque, and point 3 the breakdown torque. Note that the current at locked rotor is about 600% of full load current. This

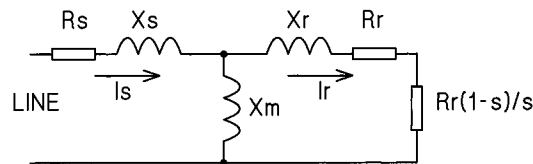

FIGURE 8.5 Induction motor equivalent circuit.

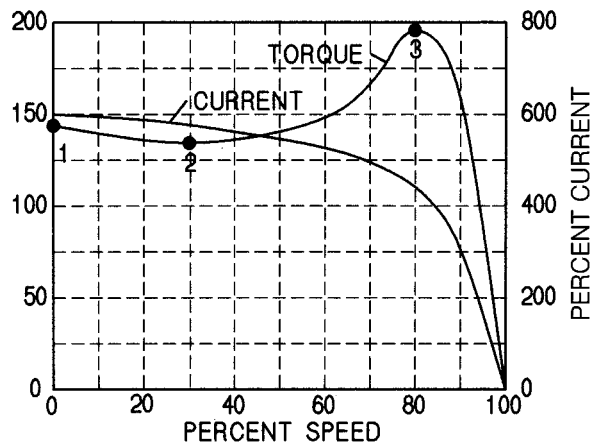

FIGURE 8.6 Induction motor torque and current.

current must be supported by the power source during the acceleration period of the motor, and that may require special fusing or circuit breaker settings. The starting line current can be reduced with resistor, reactor, autotransformer, or SCR starting—but at the expense of available torque.

The rotor resistance is the key to torque production. A large rotor resistance provides high torque capability but decreases the efficiency and increases the running slip. Motors designed for high torque will have high-resistance rotor bars and may even have solid iron rotors. Some are designed to tolerate variable-voltage, constant-frequency operation, although the losses are high.

When the induction motor is operated from a variable-frequency drive, the current and torque curves will largely follow those in Fig. 8.6, with the 100% speed determined by the drive frequency. The typical mode of operation is basically constant volts per hertz, although the resistance drop requires a boost in voltage as the frequency is lowered.

If the induction motor is connected to a power source and then driven above synchronous speed by supplying torque to the shaft, the torque and current curves are inverted from the usual motoring curves as shown in Fig. 8.7. This mode of supersynchronous operation is

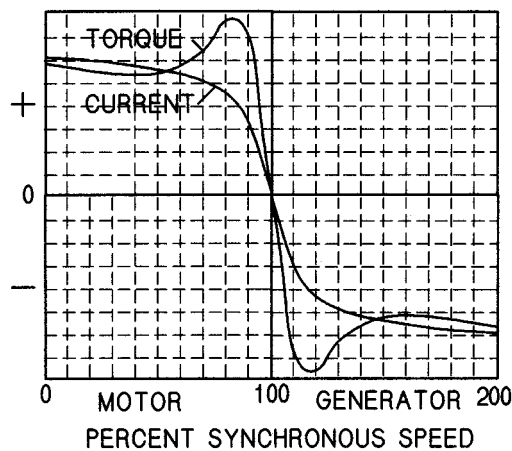

FIGURE 8.7 Supersynchronous operation.

usually confined to a small increment above synchronous speed and below the breakdown torque. Typically, the reason for operation in this mode is regeneration from an overhauling load, although induction generators are often used in small hydro stations and wind turbines on the power grid, since there is no concern for voltage and var control with an induction machine. The inverted current in Fig. 8.7 simply reminds one that the power flow has been reversed along with the torque.

When used with variable-frequency drives, modern drive logic can determine the magnetizing and load components of motor current and optimize the operating point. Known as *vector torque control* or *flux control*, this scheme has enabled precise control of the induction motor to a point where it can replace the DC motor or synchronous motor in the most demanding applications, and this includes operation in a constant horsepower, flux weakening, extended speed regime. For very large motors, however, the synchronous motor has the edge in efficiency.

#### 8.4. NEMA Designs

The National Electrical Manufacturers Association (NEMA) has defined a number of induction motor designs according to their current and torque curves with speed. Figure 8.8 shows the torque characteristics of some of these designs. Design A is a high-efficiency design with fair starting torque but high starting current. It has a low slip at rated load. Design B has a lower starting current with a fair starting torque but a higher slip at full load and is less efficient than design A. Both design A and B motors are used for pumps, blowers, and fans where starting torque requirements are modest. Design C features a high starting torque, generally obtained by dual rotor bars of high and low resistance. It has a relatively lower efficiency than A or B motors and is often used for compressors and conveyors. Design D motors are used for loads requiring an intermittent high torque with

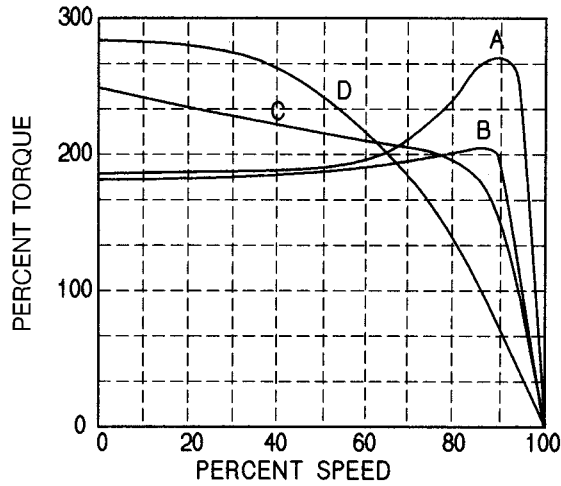

FIGURE 8.8 NEMA design torque curves.

no breakdown characteristic. Applications include punch presses and shears. They are the least efficient design.

### 8.5. Frame Types

Figure 8.9 shows some of the construction options for induction motors. At left, the open drip-proof frame offers protection from dripping water, but the shaft mounted fan ventilates the motor with whatever is in the air. This is generally the least expensive type motor. The totally enclosed nonventilated frame is shown next. This motor must

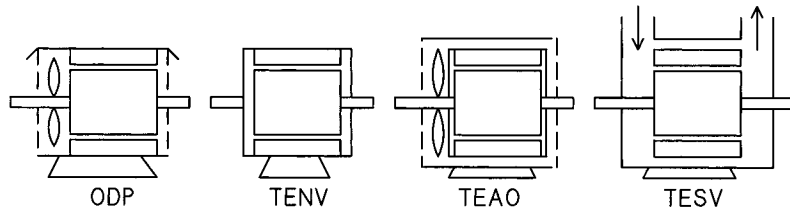

FIGURE 8.9 Induction motor frame types.

rely on radiation and natural convection from the frame for cooling, but it is not affected by corrosive or explosive fumes in the air. It is relatively expensive and larger than the ODP frame for a given horsepower. In the totally enclosed air-over design, the cooling of the TENV motor is augmented by a shaft-mounted fan that blows air over the frame. Finally, the totally enclosed, separately ventilated motor is cooled with externally supplied air.

### 8.6. Linear Motors

Although this chapter is titled *rotating machines*, an exception should be made to introduce the linear induction motor. In principle, an induction motor stator can be sawed open and then fanned out into a straight line. When excited with three-phase power, it will apply a force parallel to the linear windings in an aluminum or copper plate in close proximity. Replicating a set of windings in a line allows the motor to be extended mechanically as far as desired. By means of SCR switches, coil sections can be switched in only when the plate is in the vicinity of the particular coil set to economize on the required power. A system of this sort is currently being actively investigated in the EMALS program, an electromagnetic aircraft launching system sponsored by the U.S. Navy for new aircraft carriers. EMALS offers the capability of controlling the applied accelerating force to accommodate both drones and the largest carrier aircraft. Furthermore, it will require less maintenance and operating manpower than the steam catapults. The present EMALS program requires about 200 peak MW and 100 MJ from a stored energy generator. The generator output is controlled by a set of SCR converters to produce a variable-voltage DC bus that powers a set of inverters and coil switches for the linear motor.

Yet another interesting application for a linear motor (of a sort) is the rail gun. Figure 8.10 shows the nature of the system. When a shorting bar is placed across two current-carrying conductors, a Lorentz force is produced that acts on the shorting bar. If the bar is

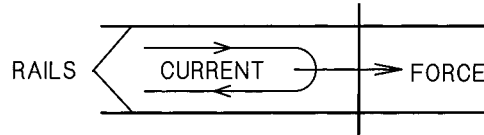

FIGURE 8.10 Elementary rail gun.

free to move with a brush system to maintain contact with the conductors, it will accelerate rapidly. Such systems are presently under development to provide weapons with hypervelocity projectiles.

The development challenges in this project are daunting. The shorting bar must make good contact with the rails, yet the currents are in the order of several MA. Rail erosion from arcing must be kept in reasonable bounds. When the projectile exits the rails, a short or terminating resistor must be used to limit the voltage from energy stored in the rail inductances. Power must be supplied from rotational generator energy and SCR converters used to control the current. The system must ultimately be installed in a military vehicle of some sort where space and weight are severely limited. Despite all these difficulties, a development system has been demonstrated, and work on this fascinating project continues at this time.





## Chapter 9

---

---

# Rectifiers and Converters

Despite the general acceptance and growth of AC power systems, the need continued for DC in electrochemistry, variable speed motors, and traction systems. Although George Westinghouse demonstrated AC traction motors, they were operated at 25 Hz rather than the prevailing 60 Hz used for utility systems. Metropolitan transit systems, however, required DC for the traction motors. The New York subway system generated and distributed 25-Hz power but ran the cars on DC through rotary converters. With the predominately 60 Hz power systems, the problem became one of converting 60 Hz AC to DC. The terms *rectifier* and *converter* are often used interchangeably to denote a system of any sort that converts AC to DC. Present-day usage seems to favor *rectifier* to denote an uncontrolled conversion system and *converter* to denote a controlled system.

### 9.1. Early Rectifiers

Rotary converters, double wound, rotating synchronous machines, had been used on 25-Hz power to generate DC since the early days. The need for DC by some industries had influenced the choice of 25 Hz for the initial generation at Niagara Falls because, in the early days of magnetic materials, it was difficult to make the rotary convert-

ers operate on 60 Hz. In later years, such operation became feasible, and rotary converter substations were scattered around the outlying regions of urban transit systems to provide DC for the trolley wires. Generally a large-diameter, narrow machine, the rotary converter was a fixture in DC power conversion for more than half a century.

Copper oxide rectifiers had been used for some years in small DC power supplies for battery chargers and similar applications. They had also been used for meter rectifiers. However, the copper oxide rectifier was not efficient enough for higher-power applications, nor was the voltage capability sufficient. Later, selenium rectifiers were developed that permitted power densities approaching  $1 \text{ A/in}^2$  of plate and 30 V per plate. They could be operated in series and parallel combinations with no concerns about sharing either voltage or current. Although they were rather bulky and somewhat inefficient, they served a need and were popular for many years in applications from radio and television receivers to industrial plating rectifiers and welders. In high-voltage stacks, they were used in electrostatic precipitators.

Other methods of rectification were vacuum tubes and mercury vapor rectifiers, both of which were suitable for use in the higher voltages. Vacuum tubes had a relatively high forward voltage drop but were suitable for the radios of the day that required several hundred volts at a hundred milliamperes or so for operation. Efficiency was of little concern in that application, but the high losses of vacuum tube rectifiers negated their use in higher-power equipment. However, they found a niche application in high-voltage CRT anode supplies for television receivers, where they were operated from a flyback transformer on the 15.75-kHz horizontal deflection system.

## 9.2. Mercury Vapor Rectifiers

A useful variant of the vacuum tube rectifier emerged in the form of a mercury arc rectifier. These tubes utilized a low-pressure mercury vapor in a vacuum environment. The mercury was vaporized by a

heated filamentary cathode. The voltage drop was typically around 15 V, and they could be built for operation at several tens of kilovolts. As hot cathode tubes, they were widely used in communications, where they supplied DC voltages for most radio transmitters at power levels as high as 1 MW in voltages from 5 to 15 kV.

Very large rectifiers were made with evacuated glass and metal enclosures containing multiple anodes and a pool of liquid mercury. They were used with the double-wye interphase transformer circuit described later to provide high currents for electroplating and DC service buses for metal processing mills. They also supplied high-current “pot lines” for the electrolytic reduction of aluminum and other metals as well as chlorine production. A starter electrode vaporized the mercury in these units, and the tanks were maintained at a low pressure by vacuum pumps.

Later developments included a sealed glass and metal enclosed high-current rectifier with an ignitor electrode that permitted it to act as a high-current switch. Sold under the trade name Ignitron<sup>®</sup>, these units became very popular and ruled the rectifier field until the development of solid-state technology in mid century.

### 9.3. Silicon Diodes—The Semiconductor Age

The now-familiar silicon diode grew out of the development of the point contact germanium transistor by Brattain and Bardeen at Bell Laboratories in 1947. Later work in many laboratories resulted in alloyed junctions, higher current capabilities, and the transition from germanium to silicon. By 1960, silicon rectifiers were widely available and coming into general use. Germanium power rectifiers were available in large sizes, but their restricted temperature capabilities limited their use.

The advantage of silicon for diodes was that it could operate at junction temperatures approaching 200°C. Their forward drop was higher than that of germanium diodes, but the higher temperature

capability more than made up for it in their permissible power density. The early silicon diodes were silicon wafers soft soldered to a copper substrate that served as a mounting and one electrical pole. The other was made from a soldered wire attachment to the other side of the wafer that was brought out through insulation.

As the size of silicon diodes grew, it became apparent that temperature cycling with operation would fatigue the solder joints, so brazing techniques were developed. Next came the use of a metallic interface wafer with a low thermal index of expansion that was close to that of silicon. The silicon wafer was brazed to the metal, usually tungsten or molybdenum. Large diodes are now sometimes made with a floating silicon wafer that is compressed with an external clamp.

#### 9.4. Rectifier Circuits—Single-Phase

The simplest rectifier is the half-wave circuit shown in Fig. 9.1. This circuit is often used for low-power rectifiers operating directly from the AC power line. It can deliver power to a resistive or capacitive load. The half-wave rectifier draws DC and even-order harmonic currents from the source, in addition to the usual odd-order harmonics that characterize most nonlinear loads. If a transformer is used, the

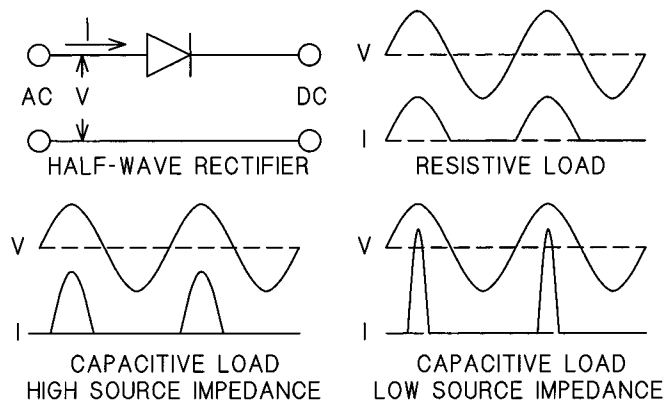

FIGURE 9.1 Half-wave rectifier characteristics.

DC component may saturate the iron, but a gapped core can allow flux reset and prevent this.

Half-wave rectifiers are often used with filter capacitors to provide a low-ripple DC output. The capacitive load makes the line current conduction angle decrease as shown in Fig. 9.1. High-frequency harmonic currents increase, and the apparent power factor,  $P/VA$ , decreases. The rectifier in this case is subjected to a peak reverse voltage equal to the capacitor voltage plus the peak line voltage. Since the capacitor usually is charged to near peak line voltage, the diode must be rated for repetitive operation at twice peak line voltage.

Although the half-wave circuit is widely used in switch-mode power supplies where the poor current waveform may not cause a problem, an aggregation of such power supplies can have serious effects on the power system in, for example, a data processing center. Single-phase loads with such current distortion have a high percentage of triplen harmonics, both even and odd order—3, 6, 9, 12, 15, 18, 21, .... These triplen harmonic currents are additive in the neutral of a three-phase distribution system, and the neutral current can approach twice the line current. Oversized neutral conductors are required. Equipments that cause DC components in the supply lines of electric utilities are not permitted by IEEE 519, but the DC components of half-wave power supplies do not pass beyond the first transformer they encounter. However, they may cause the core of the transformer to saturate.

The full-wave, center-tapped rectifier shown in Fig. 9.2 was widely used in the days of radio, because the two rectifying elements could be contained in the same vacuum tube. It is still popular for low-voltage supplies, since there is only a single rectifier element in series with the load. However, many of these simple rectifiers have been superseded by switch-mode units that are much smaller and lighter because of their high-frequency transformer. These are described in Chapter 13.

The secondary sections in this circuit carry half-wave currents with an rms value of 50% of peak over a full cycle. With a primary voltage

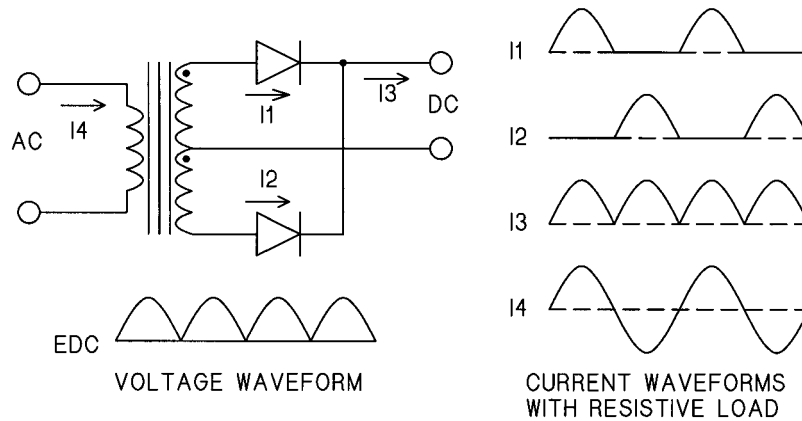

FIGURE 9.2 Full-wave, center-tapped rectifier circuit and waveforms.

of 1.0 Vrms and a secondary voltage of 1.0 Vrms each side of center tap and a resistive load of  $1.0 \Omega$ , each secondary current is 0.707 Arms, and the primary current is 1.0 A rms. Circuit voltamperes are 1.0 VA. The transformer has a primary rating of 1.0 VA, but each secondary must be rated at 0.707 VA. Thus, the transformer must have a VA rating of  $(1 + 0.707 + 0.707)/2 = 1.207$  VA. It must be some 20% oversized for the circuit rating because of the half-wave currents in the secondary sections.

Figure 9.3 shows the familiar bridge circuit. Here, the transformer is fully utilized, since both windings carry sinusoidal currents. The bridge circuit has twice the diode losses of the center tap circuit, because there are two diodes in series with the load. However, the transformer losses are lower because of reduced harmonic currents. Encapsulated diode assemblies are available for use in any of the above circuits.

### 9.5. Rectifier Circuits—Multiphase

A widely used rectifier circuit, especially for low-voltage, high-current rectifiers, is shown in Fig. 9.4 at the left. In the days before the

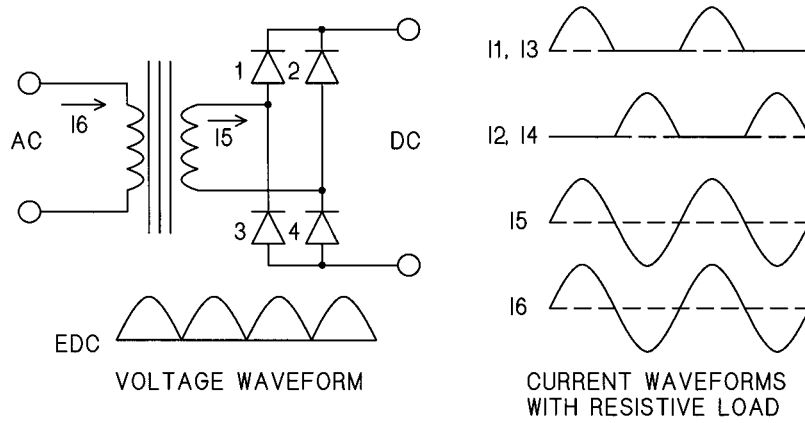

FIGURE 9.3 Single-phase bridge (double-way) rectifier and waveforms.

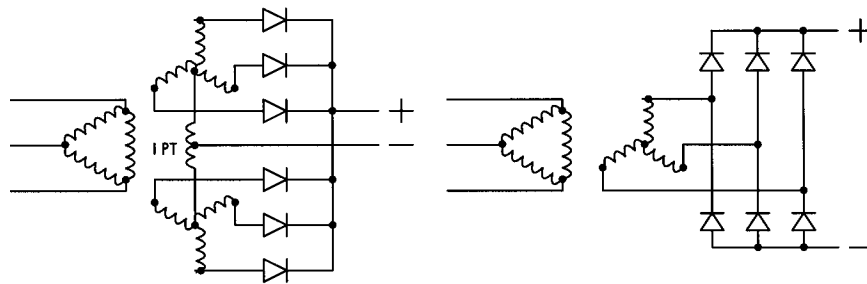

FIGURE 9.4 Three-phase double-wye interphase and bridge rectifier circuit.

availability of efficient silicon rectifiers and controlled rectifiers, this was the customary circuit. It is called a delta six-phase double-wye, USAS Circuit 45. An interphase transformer is used to allow  $120^\circ$  conduction in the rectifiers. Only a single rectifier is in the series circuit between each transformer winding and the return from the load; hence, the argument goes, it is more efficient than the bridge circuit at the right, a delta six-phase wye, double-wye, USAS Circuit 23, that has two rectifiers in series. But things are really not quite so simple. The rectifier losses are indeed cut in half. However, the circuit at left has transformer secondary windings that conduct half-wave currents and will probably have higher eddy current losses than the transformer at right. The interphase transformer introduces still more

losses. Also, the capital cost is increased by the lower kVA efficiency of the secondary windings and the need for an interphase transformer.

Magnetics costs generally outweigh semiconductor costs by a considerable degree, so the circuit selection based on the lower life-time costs must consider the long-term cost of capital as well as the operational cost of losses. However, this may be a hard sell to many users who have been buying rectifiers for years, because the myth of superiority of the interphase circuit is well established in the industry. As a compounding factor, the transformer vendors seldom will warrant the efficiency of their transformers with anything but sinusoidal currents, so the additional losses from half-wave conduction and the added eddy currents seldom appear in quotations from them. *Caveat emptor!*

The instantaneous DC voltage from the interphase circuit is half of the sum of the two most positive secondary voltages when the interphase exciting current is negligible compared to the load current, and the diodes conduct  $120^\circ$ . The average DC voltage is 0.891 times peak line-to-neutral voltage, 1.260 times rms voltage. At very light loads, the voltage rises to 0.955 times peak voltage or 1.350 times rms voltage, and the diodes conduct only  $60^\circ$ .

Each secondary carries an rms current of  $\sqrt{1/3} = 0.5773$  times the DC current, and the primary current is  $\sqrt{2/3} = 0.8165$  times the DC load current for inductive loads.

For the bridge circuit, the average DC voltage is 0.955 times peak line-to-line voltage or 1.350 times rms voltage independent of load, and the diodes always conduct  $120^\circ$ . The rms line current for the bridge is equal to  $\sqrt{2/3} = 0.8165$  times the DC load current for inductive loads. These ratios all neglect commutation effects which are covered in the next section.

These two circuits touch only on the variety of rectifier circuits that are in common use. For example, the transformer configuration shown in Fig. 7.17. can be used to form a 24-pulse rectifier that has principal harmonics of order  $24 \pm 1$  (23, 25, 47, 48, ...) for low distortion in the line current. ANSI C34.2 describes many special circuits.



## 9.6. Commutation

Three-phase rectifiers transfer the load current from phase to phase in sequence. The current cannot be transferred instantaneously, however, because of inductance in the supply. The process of driving the current out of one phase and into another is termed *commutation*, and it always results in a loss of output voltage to the load. Figure 9.5 illustrates the process for a three-phase bridge rectifier.  $V_A$ ,  $V_B$ , and  $V_C$  are the line-to-neutral voltages. At time 1, the current is flowing from phase A through the positive bus to the load and returning through the negative bus to phase C. The positive bus voltage is the phase-A voltage. At time 2, the positive phase-B voltage is becoming greater than the positive phase-A voltage, and the current begins to transfer from phase A to phase B. The voltage driving the current transfer is the line-to-line voltage  $V_{BA}$ . During this period, the positive bus voltage is the average of phase A and phase B voltages. At time 3, the current transfer into phase B is completed, and the positive bus voltage is now the phase-B voltage.

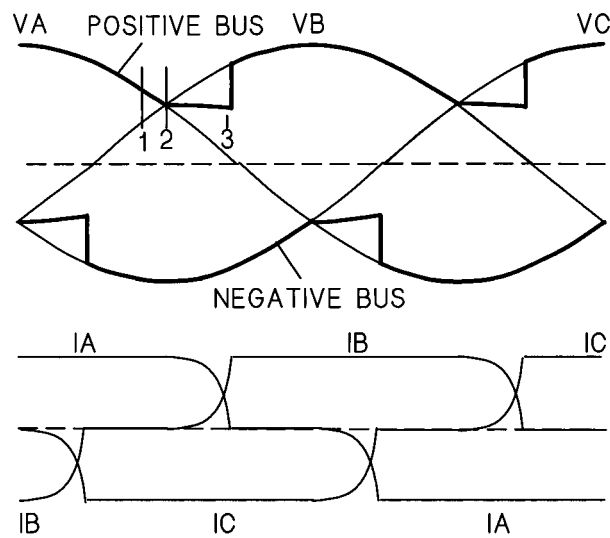

FIGURE 9.5 Commutation in a three-phase bridge rectifier.

The same process of current transfer takes place on the negative bus as well, and the output voltage of the bridge is always the difference between the positive bus voltage and the negative bus voltage. A commutation is taking place every  $60^\circ$ .

Commutations are driven by the voltage difference between the outgoing and incoming phases. Initially, the difference voltage is zero in a rectifier, and the  $di/dt$  is also zero. The commutating current can be visualized as a current that circulates from the incoming to the outgoing phase. It is equal to the time integral of the voltage difference divided by the sum of the source inductances in each of the two phases. The circulating current is the current in the incoming phase, and it subtracts from the current in the outgoing phase. Commutation is completed when this current is equal to the load current.

Calculation of the commutation voltage loss is simplified by the use of per unit constants. If the rated line-to-neutral voltage is  $V_{rms}$  and the rated line current is  $I_{rms}$  for a rectifier, the base impedance is  $Z_{base} = V_{rms}/I_{rms}$ . The per unit source reactance is then

$$X_{pu} = \frac{\omega L}{Z_{base}}$$

where  $\omega$  is the source frequency, and  $L$  is the inductance of one phase of the source. Then,

$$E_d = E_{do} - \frac{I_{pu} X_{pu}}{2}$$

where  $E_{do}$  is the no-load DC voltage,  $E_d$  is the voltage under load, and  $I_{pu}$  is the percent rated load current divided by 100. The commutating angle,  $u$ , is given by  $\cos(u) = 1 - I_{pu} X_{pu}$ . The several formulae assume that there is no commutation overlap; i.e., the commutation angle is less than  $360/p$  where  $p$  is the pulse number of the converter. These relationships will be revisited when converters with phase-controlled SCRs are discussed.

## Chapter 10

---

---

# Phase Control

The invention of mercury arc rectifiers in the 1920s made it possible to control a load voltage by varying the conduction angle of a rectifier with a low-power control ignitor. Later years produced the gas-filled thyatron that extended this capability to lower-power equipments. Motor drives, welders, controllers, and a host of other applications followed, but the limitations in reliability and efficiency, coupled with the relatively high cost of this equipment, precluded widespread use. The market was confined to special applications where the advantages outweighed the disadvantages.

A second approach to phase control involved magnetics in the form of saturable reactors and magnetic amplifiers. Saturable reactors had been used for many years in applications that could tolerate a relatively slow response time, and advances in metallurgy brought “square loop” magnetic materials that improved the characteristics of these devices. In the early 1950s, the combination of improved magnetics and low-leakage selenium rectifiers had advanced the art of magnetic amplifiers to a point where they were used in autopilots for military aircraft, but their slow response and high weight were far from ideal.

### 10.1. The SCR

The development of the SCR (technically a silicon controlled rectifier or thyristor) in the late 1950s spawned a host of new power electronics systems. The SCR made it possible to not only rectify AC power at high currents and voltages but also to control the output with a low-power control voltage. And the response time was as fast as the power line frequency permitted. SCRs advanced rapidly in ratings until, at this time, they are pushing 10 kV and 10 kA for a single device. They can be connected in series and parallel for unlimited voltages and power levels.

The SCR consists of a four-layer sandwich of P and N doped silicon layers with a gate electrode that can initiate an avalanche discharge. A two-transistor analogy is shown in Fig. 10.1. The device exhibits a low leakage current with both forward and reverse applied voltages when there is no gate signal. Application of a voltage between gate and cathode, however, allows the SCR to conduct with a very low resistance in the forward direction, i.e., positive anode and negative cathode. The SCR then latches on and remains in conduction until the supply reverses the anode-cathode voltage.

During the process of turning on, the SCR must go through a transition period when the voltage across the anode-cathode and the current through it are both high. Hence, it is necessary to get through this transition as quickly as possible to minimize the dissipation. The area

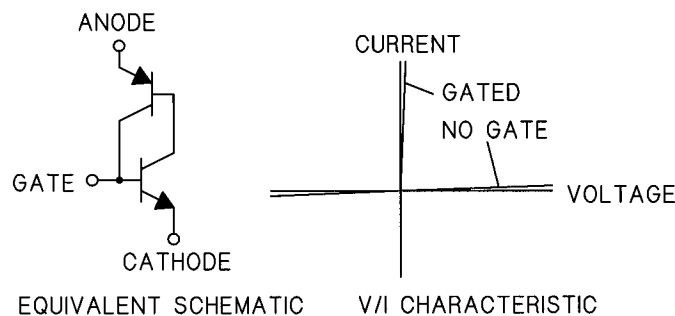

FIGURE 10.1 SCR characteristics.

of cathode that is in conduction grows with time following the initial application of a gate signal. The process may require a number of microseconds for full conduction. SCRs that must handle high turn-on  $di/dt$  are often made with interdigitated gate structures so that the maximum cathode area can be turned on as quickly as possible.

The gate is generally driven by a pulse of several amperes rising in 500 ns or less and is followed by a current of 500 mA for the remainder of the time during which the SCR is supposed to be in conduction. Many variations of single and multiple pulsing are used with SCRs, but these numbers will give some general guidance. The gate voltage source is usually several tens of volts with current limiting. SCRs designed for operation at higher than the normal power frequencies of 50 or 60 Hz or in circuits with high values of turn-on  $di/dt$  may require more exotic gate drives. Vendor data sheets should be carefully studied for gate drive needs, but the turn-on dissipation is not usually a design consideration at power frequencies. A typical gate drive waveform is shown in Fig. 10.2. Gate connections should be run in twisted pair or coax with the cathode lead terminated on the SCR.

The turn-off process in an SCR is quite a bit more complicated than the turn-on. Forward conduction is made possible by charge carriers in the silicon, and these must be allowed to dissipate before the SCR can block forward voltage following turn-off. When charge carriers

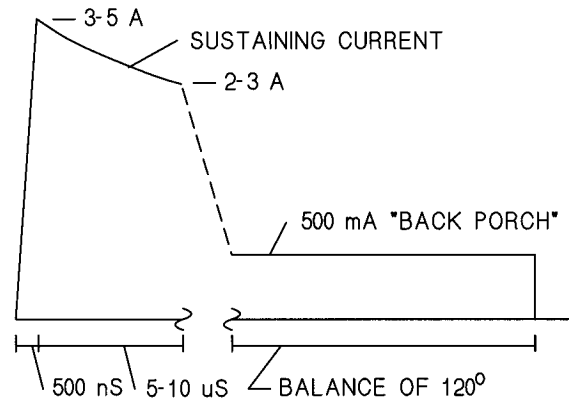

FIGURE 10.2 Typical SCR gate drive.

are present, the device is just as willing to conduct reverse current as it is forward current. A particular SCR design is characterized by two parameters, the ranges of which are specified in the data sheet. These are the recovered charge,  $Q_{rr}$ , and the peak reverse current,  $I_{rr}$ , both of which are dependent on the junction temperature and the circuit  $di/dt$  as the current passes through zero and reverses.

SCR recovery can be simulated with a simple computer program. A representation of this process, devised by Waldmeyer and Backlund of the ABB semiconductor operation in Switzerland, is shown in Fig. 10.3. The SCR is initially represented as a short circuit to determine the circuit  $di/dt$ . The circuit current proceeds to zero, reverses as shown, and reaches a peak of rated  $I_{rr}$ . The time required,  $t_x$ , is then  $I_{rr}/(di/dt)$ , and the charge to this point,  $Q_1$ , is equal to  $(I_{rr} t_x)/2$ . Following the peak at  $I_{rr}$ , the current through the SCR will decay exponentially to zero. If the calculated value of  $Q_1$  is subtracted from the data sheet  $Q_{rr}$ , the difference is shown as  $Q_2$ . Then, the formula for the exponential decay of current is  $i = I_{rr} e^{-t/\tau}$  where  $t$  is the time from peak current and  $\tau$  is equal to  $Q_2/I_{rr}$ . The initial rate of recovery  $dir/dt$  is equal to  $I_{rr}/\tau$ . Note that this  $dir/dt$  may be several times the circuit rate of  $di/dt$ , and this has implications for transient voltages across the SCR. This representation is a simplified version of the actual complex recovery waveform, but it is useful for snubber design purposes.

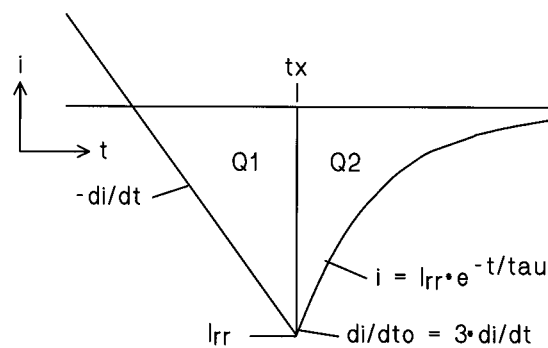
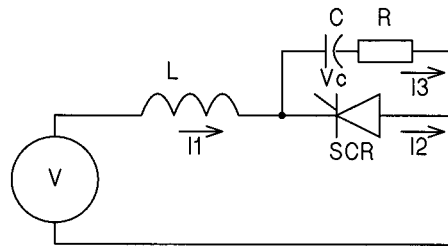

FIGURE 10.3 SCR recovery characteristics.

The recovery characteristic in Fig. 10.3 shows the SCR current but leaves the circuit voltages in limbo. These can be determined from the equivalent circuit of Fig. 10.4, in which an R/C network is shown across the SCR. This network is called a *snubber* and is almost always required in power SCR circuits. The circuit is driven by the source voltage and an inductance that determines the  $di/dt$  as the circuit current goes through zero. Initially, the resistor and capacitor are effectively shorted as the SCR conducts reverse current, and  $I_2 = I_1$  while  $I_3$  is zero. Current  $I_1 = I_2$  will increase until it reaches the value of  $I_{rr}$  for the SCR. The SCR then acts as a current source with  $I_2$  given by an exponential decay from  $I_{rr}$  as determined from the procedure shown in Fig. 10.3. The circuit parameters may be solved by the Euler numerical integration of the difference equations shown in Fig. 10.4.

A number of interrelated design choices can be made from the results of this simulation. Of primary importance is the peak reverse voltage to which the SCR is subjected. The snubber should be designed to provide a safety margin below the rated peak reverse voltage for the SCR. Capacitor and resistor values can be juggled to limit this voltage and provide good circuit damping. Trade-offs involve the



$$I_1 = I_1 + (V - V_c - I_3 R) \cdot \frac{dt}{L}$$

$$I_3 = I_1 - I_2$$

$$V_c = V_c + I_3 \frac{dt}{C}$$

$$V_{scr} = V_c + I_3 R$$

FIGURE 10.4 Equivalent SCR recovery circuit and difference equations.

rather considerable cost of the capacitor, which must be an extended foil type, and the dissipation of the resistor, which must be a noninductive type. A secondary consideration may be the turn-on  $di/dt$  limit of the SCR, since it must discharge the capacitor through the resistor. The resistor dissipation must include this discharge energy as well as the turn-off dissipation from the recovery simulation. Note that many circuits involve a number of snubber networks that will interact, and the R/C values for the simulation must be the equivalent shunt values as seen by the recovering SCR. For the three-phase full wave converter, the equivalent resistor,  $R_{eq}$ , is given by  $R_{eq} = 3R/5$ , where  $R$  is the actual resistor on each SCR, and  $C_{eq}$ , the equivalent capacitor value is  $C_{eq} = 5C/3$ . These R/C values can then be adjusted by the inverse relationship to define the actual values for the snubber components. The snubbers should be mounted as close to the SCR as possible to minimize stray inductance.

Some vendors define the recovery characteristic by an “s” factor that can be used to determine the current decay time constant. The maximum recovery  $dir/dt$  is equal to the circuit  $di/dt$  divided by the s factor, typical values for which are 0.33 for SCRs and as low as 0.1 for some diodes. The exponential time constant,  $\tau$ , is equal to  $I_{rr}/(dir/dt)$  as before.

It is important to coordinate the maximum SCR recovery voltage with the voltage rating of MOV devices used for transient protection. The recovery voltage cannot be allowed to reach the MOV clamping voltage, because this would cause overheating and failure of the MOV. The MOV is rated for occasional transients only, and it cannot withstand exposure to repetitive transients such as those of SCR recovery.

Recovery dissipation for the SCR can be determined by integrating its  $I_{rr} \cdot V_r$  product from the simulation. This is usually a nontrivial value for large SCRs, even at power frequencies. An estimate of these losses is included in the vendor’s data sheet for allowable currents at various firing angles at power frequencies, but a more serious evaluation is often warranted, especially in higher-frequency operation, since switching losses are proportional to the source frequency.



## 10.2. Forward Drop

SCRs have a nonlinear forward drop that is usually the major determinant of the allowable load current in a circuit. The rated currents often can be obtained from a series of curves most vendors show for various phaseback angles. If the operating conditions do not correspond with any published curves, the losses must be calculated from the current waveform and the forward drop. A given SCR in a three-phase bridge conducts only about  $120^\circ$ , neglecting commutation, per cycle. It is important to calculate the power from the integrated  $V I$  product using the actual current waveform. This power can then be divided by three to get the average value over the cycle. The loss power cannot be determined by using the average current.

Two identical semiconductors with different duty cycles can be compared for losses. The first is carrying pulses of 100 A on a 10% duty cycle with an average current of 10 A. The second is carrying 10 A on a 100% duty cycle. A forward resistance drop of  $0.1 \Omega$  is assumed. The first dissipates 1000 W on a 10% duty cycle for 100 W average. The second dissipates only 10 W. The peak junction temperature rise of the first will be more than ten times that of the second.

The preceding discussion is a rather condensed treatise on the care and feeding of SCRs, and it is suggested that the reader study the available technical literature as well as vendor data sheets for more specific design information.

## 10.3. SCR Circuits—AC Switches

Figure 10.5 shows two SCRs connected back-to-back in a single-phase AC switch configuration, each handling one polarity of the AC source voltage. The fraction of each half-cycle of the voltage that is delivered to the load is controlled by the timing of the gate signals. The angle from the positive going zero crossing of the voltage to the application of the gate signal is the delay angle or firing angle,  $\alpha$ . Figure 10.6 shows the output voltage and current waveforms for various delay angles and load power factors.

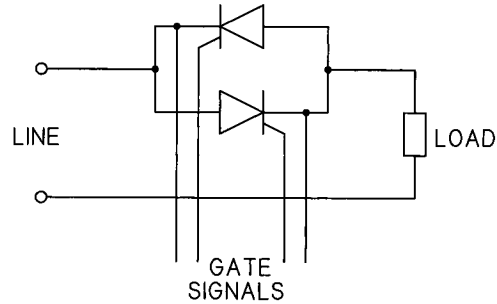

FIGURE 10.5 Single-phase SCR AC switch.

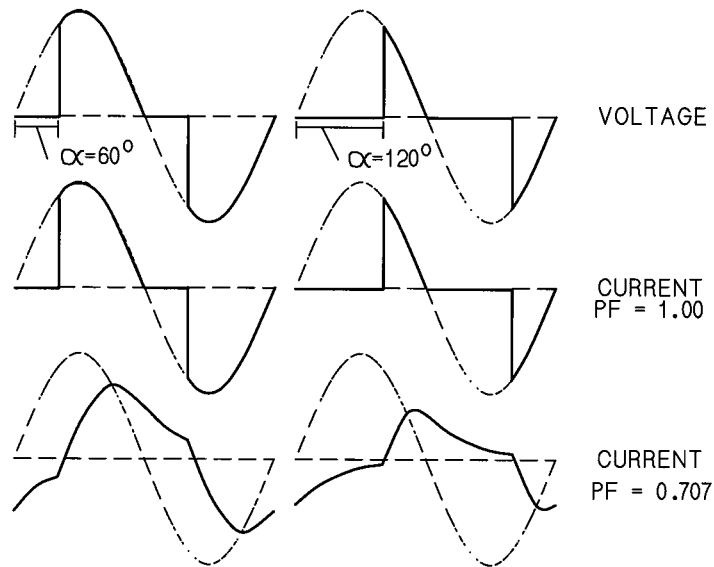

FIGURE 10.6 SCR single-phase AC switch waveforms.

These switches are widely used in light dimmers, process heaters, annealing lines, voltage regulators, and many other applications where single-phase control is required. They operate at a poor power factor with phaseback. Although the power factor approaches zero at high phaseback angles, the var consumption decreases for constant-impedance loads. The var consumption may be quite low relative to the maximum kVA with zero phaseback. These switches have a rich

series of current harmonics with a spectrum that contains all odd-order harmonics of the supply frequency.

An AC switch can be used to gradually phase on the voltage and minimize exciting current inrush when a transformer is energized. This characteristic is also valuable when the transformer supplies a rectifier with a capacitive load. Another use is to minimize the inrush current on the cold filament of an incandescent lamp. The cold resistance of an incandescent lamp is only a fraction of the hot resistance, and minimizing the inrush current may extend filament life. This is especially true for large flood lamps and special types with heavy filaments.

The AC switch is also used in three-phase configurations as shown in Fig. 10.7. The in-delta switch behaves as three independent single-phase switches controlling the line-to-line voltage to each load, and line current is the sum of two delta currents. This connection can be used only when the load can be split into three isolated sections. The in-line configuration shown at the right in Fig. 10.7 is far more common. Applications follow those of the single-phase switch with the important addition of reduced current starters for induction and synchronous motors. In this application, SCR starters have presently been made in ratings to 10,000 hp at 13.8 kV.

Waveforms of the three-phase in-line AC switch are rather complex. Figures 10.8 and 10.9 show switch operation with a 0.80 power factor lagging load and phaseback angles of  $60^\circ$  and  $120^\circ$ , respectively. In

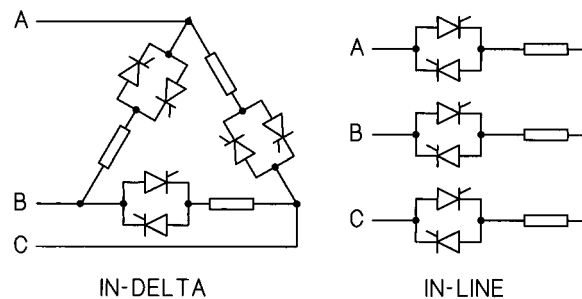

FIGURE 10.7 Three-phase SCR AC switches.

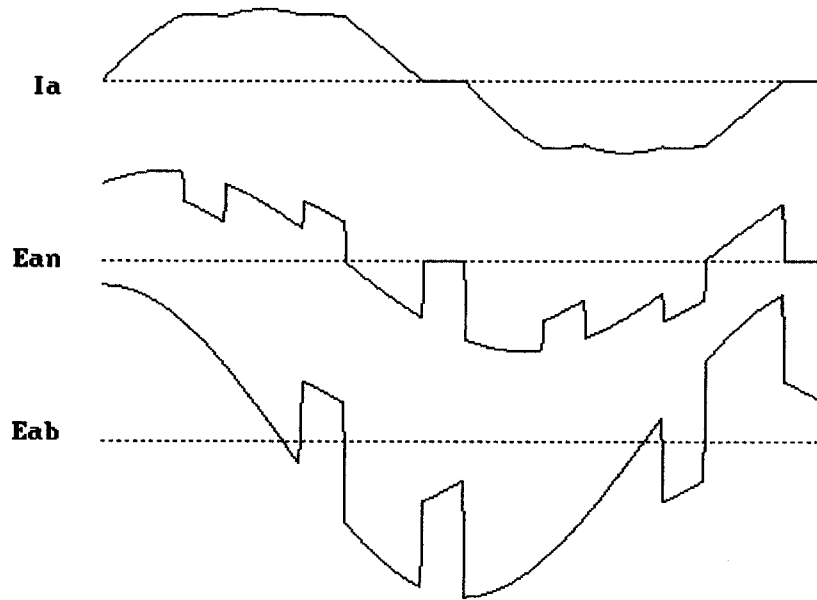

FIGURE 10.8 Three-phase AC switch, 60° phaseback, 0.8 pf lagging load.

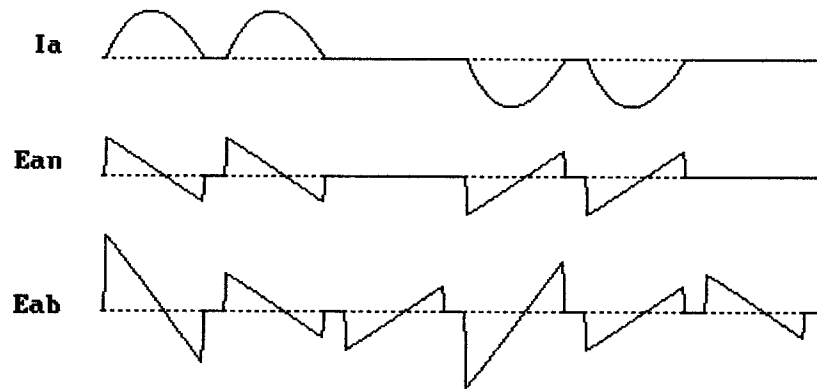

FIGURE 10.9 Three-phase AC switch, 120° phaseback, 0.8 pf lagging load.

Fig. 10.8, the current is discontinuous, but if the phase delay were slightly less or the power factor lower, it would be continuous. Figure 10.9 clearly shows the discontinuous current and chopped voltage characteristic of the larger delay angles.

## 10.4. SCR Motor Starters

These waveforms are similar to those encountered with reduced current motor starters, although the induction motors usually have a lower power factor on starting. Induction motors started across the line will draw initial currents of five or six times full load current. These high currents may cause problems with lamp flicker or voltage sags on other critical equipment connected to the same feeder. SCR starters can reduce these problems—but at the expense of a reduced starting torque on the motor. Torque is proportional to the square of the motor current, so a reduction in current to 50% of normal line current reduces the starting torque to only 25%. However, many loads, such as centrifugal fans and pumps, can start with these low torques because, except for friction losses, their torques tend to increase as the square of the speed.

The combination of a low motor power factor and a large phaseback angle for current control means the SCR starter may present a very low power factor to the feeder and thereby aggravate the voltage drop. Furthermore, the high harmonic content of the current may exceed allowable limits by the utility. One solution to both problems is to use power factor correction capacitors coupled with one or more series tuning inductors to improve power factor and divert harmonic currents from the feeder. The capacitors may be switched in and out as required to keep the voltage within acceptable limits. If sufficient capacitors are used to maintain bus voltage at maximum starting current, they must be switched out to avoid overvoltages at normal running currents.

SCR starters are usually operated at a constant current equal to the minimum value required to satisfy the load torque requirements. An advantage of these starters is that the regulated current can be ramped up to the regulated level so that there is no sudden current demand on the feeder, and the voltage drop is gradual. A gradual reduction in lamp brightness is much less objectionable psychologically than a sudden drop.

Figure 10.10 shows the starting characteristics of a 2500-hp induction motor driving a centrifugal pump. The current has been linearly

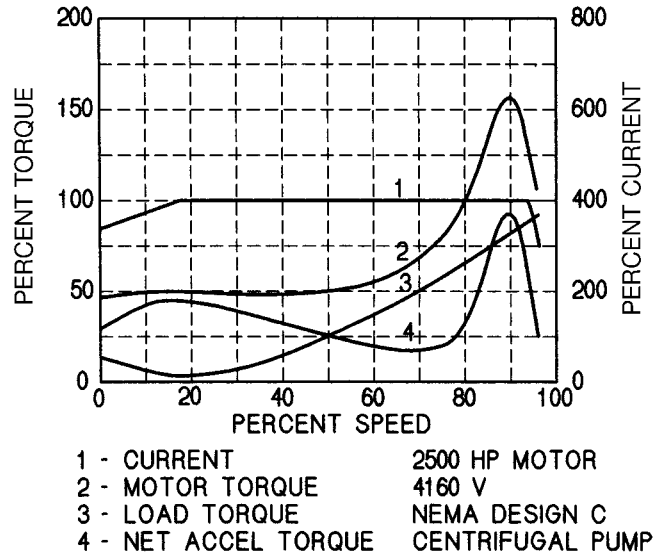

FIGURE 10.10 Starting characteristic of induction motor with SCR starter.

increased from zero to 400% on a 20-sec ramp. The motor breaks away at around 350% current and begins to accelerate. Curve 4 shows the net torque available for acceleration of the motor, the developed torque minus the required load torque. The speed profile is shown in Fig. 10.11.

Although it may seem counterintuitive, the use of a reduced current starter subjects the motor to more thermal stress than across-the-line starting. The integral of  $i^2 r dt$  is higher because of the extended acceleration time, even though the current is lower. An equivalent locked rotor time can be developed from the starting analysis as  $\int i^2 r dt$  and compared to the manufacturer's limit. This comparison will be conservative, because the motor is benefiting from air circulation during SCR starting, whereas there is no significant heat exchange under locked rotor conditions.

The SCR starter offers advantages in addition to control of current surges on the power line. Ramping up the current eliminates the shaft torque transient that accompanies line starting, and this reduces the mechanical stresses on connected loads. Software control of the start-

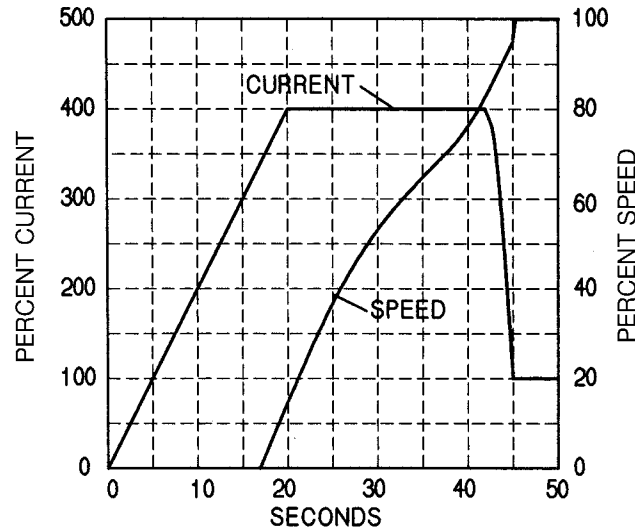

FIGURE 10.11 Speed profile with SCR starter.

ing current can provide a nearly constant load torque during starting, often a requirement for centrifuges and similar loads. Alternatively, the software can be programmed for a constant acceleration, linear speed profile.

## 10.5. SCR Converters

This class of phase-controlled systems ranges in power from industrial power supplies of a few kilowatts to 2250-MW HVDC terminals. All of the circuit arrangements discussed under the topic of rectifiers are used with SCRs for control of the DC output. By far the most common circuit is the three-phase bridge shown in Fig. 10.12. Neglecting commutation effects for the moment, this circuit has a control range of  $180^\circ$  from full positive output voltage to full negative output voltage, although the circuit requires a load such as an inductor that is capable of sinking positive current while sourcing negative voltage. The bridge circuit allows power flow in either direction for

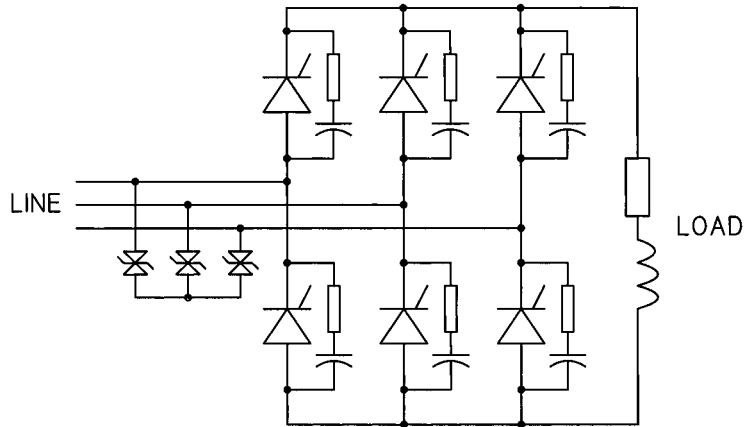

FIGURE 10.12 SCR three-phase bridge converter.

these types of loads, and it is capable of supplying regenerative braking for DC motors with field reversal. Figure 10.12 shows the R/C snubbers as well as protective MOV devices on the power line.

The set of figures that follows show the control characteristics of the SCR converter. The gate circuits are set to gate each SCR at  $30^\circ$  after the line-to-line zero crossings. Figure 10.13 shows the line-to-neutral voltages and the line currents with an inductive load, Fig. 10.14 shows the positive and negative bus voltages, Fig. 10.15 shows the line-to-line voltage of phase A, and Fig. 10.16 shows the DC output waveform. When an SCR is fired, the incoming and outgoing phases are shorted, and the output bus voltage drops to the average of the two phase voltages. The process is identical to that with diodes, except the beginning of commutation is determined by the timing of the gate delay,  $\alpha$ . The positive bus always assumes the most positive gated voltage in the system, and the negative bus follows the most negative gated voltage once commutation is completed.

The DC output voltage will continue to decrease as the firing angle is phased back farther. At  $90^\circ$  phaseback, the average output voltage will be zero with an inductive load. The converter supplies the positive portions of the voltage, and the load induces a mirror-image voltage to form the negative portions.



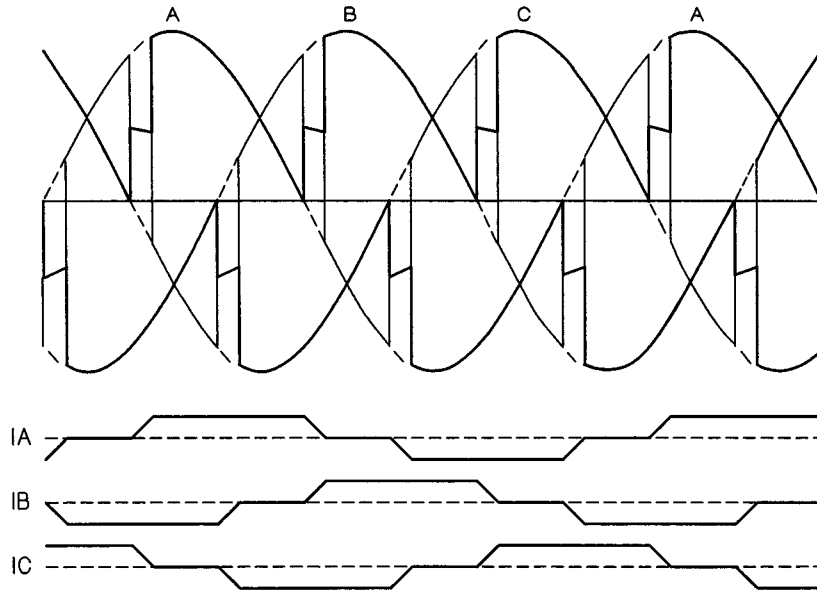

FIGURE 10.13 Converter L-N voltages and line currents (inductive load).

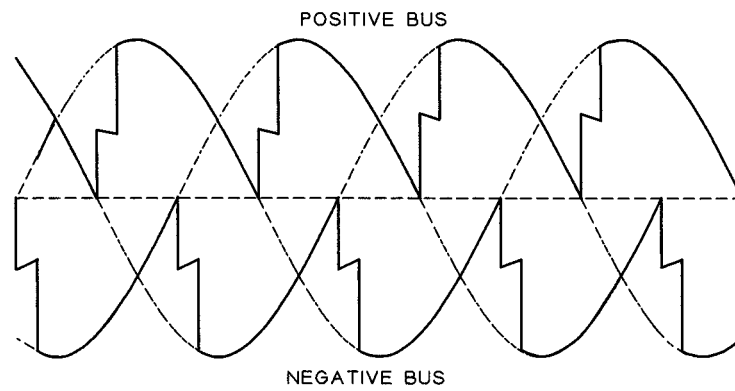

FIGURE 10.14 Converter bus voltages.

## 10.6. Inversion

Figure 10.17 shows waveforms at  $\alpha = 120^\circ$ , a region of negative output voltage where operation is possible with an inductive load already

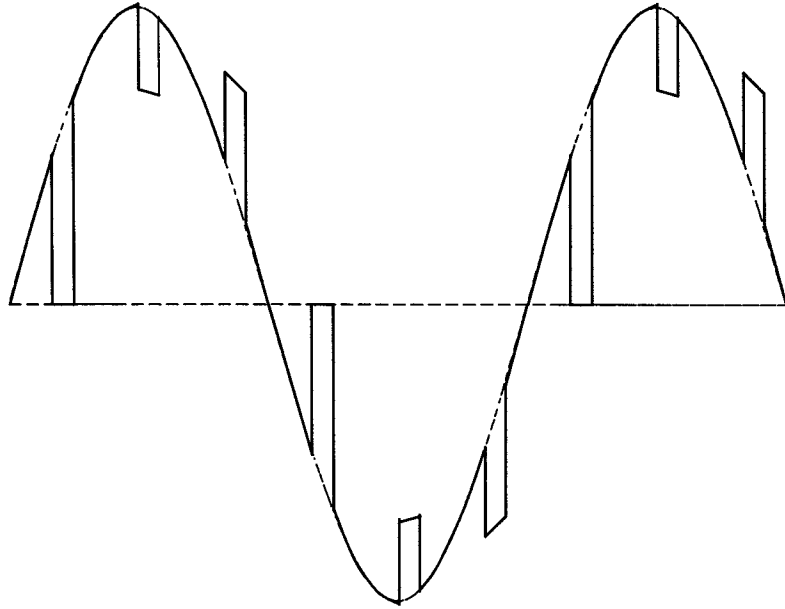

FIGURE 10.15 Converter line-to-line voltage.

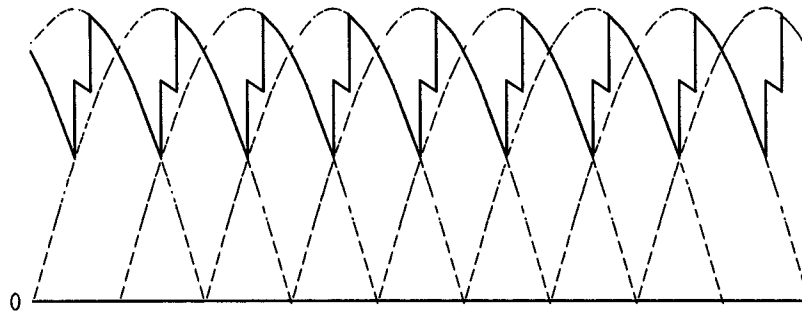

FIGURE 10.16 Converter DC output voltage.

carrying forward current or with an active load. The voltage is negative, but the current is still positive, so the power flow is from load to source. Still further phaseback is possible, but there is a limit. If commutation cannot be completed before the outgoing phase becomes more positive than the incoming phase, transfer of load current cannot

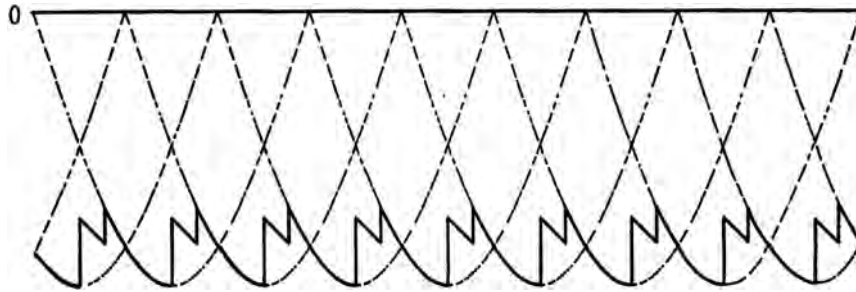

FIGURE 10.17 Converter DC inversion at  $150^\circ$  phaseback.

be completed, and the full load current will return to the original phase as the voltage swings from positive to negative. This is termed a *commutation failure*, and it leaves the full load current in only one of the SCR pairs with possible overcurrent damage. Furthermore, a large AC voltage is impressed on the load, and this may be undesirable. To avoid commutation failure, a margin angle must be observed between the maximum phaseback angle and the angle at which the commutating voltage changes polarity. A phaseback limit of  $165^\circ$  with a  $15^\circ$  margin angle is often used in relatively low-reactance systems where commutation angles are low. In special applications such as high reactance pulsed power systems, the margin angle is load compensated so that the angle can be increased as load current decreases. This allows a maximum sustained negative voltage and rapid energy recovery.

While the bridge is the most popular circuit, several other arrangements are in use. The semiconverter substitutes diodes for three of the SCRs. This circuit was popular in the early days of SCRs, when they were quite expensive, but it is used less often now. One major objection to the circuit is that it draws DC from the source. The same is true of a simple half-wave circuit that has found occasional use in the rotating rectifiers of brushless exciters for synchronous motors and generators. It not only draws DC but also requires a source with a power neutral.

Table 10.1 shows some of the basic relationships in a three-phase SCR converter. They are included for reference.

TABLE 10.1 Converter Equations

---

$$E_d = E_{do} - \frac{I_{pu}X_{pu}}{2} \quad \cos(u) = \cos(\alpha) - I_{pu}X_{pu} \quad pf \approx \cos\left(\alpha + \frac{u}{2}\right)$$

where  $E_{do}$  = no-load DC voltage  
 $E_d$  = unloaded DC voltage  
 $I_{pu}$  = per unit load current  
 $X_{pu}$  = per unit reactance of one phase  
 $u$  = commutating angle  
 $\alpha$  = phaseback angle  
 $pf$  = displacement power factor

---

### 10.7. Gate Drive Circuits

Many arrangements have been used to derive the phase references for SCR gate drives. These include phase shifters, phase locked loops, ramp intercepts, cosine intercepts, and programmable counters, among others. Most can be implemented in either hardware or software. A simple R/C phase shifter may be suitable when a limited range of phase control is satisfactory, although cascaded sections will provide a larger range. The programmable counter relies on a high-frequency reference signal that is initiated at a reference point in the line voltage. The control then counts cycles of the reference to establish a time delay which, of course, relates to phase delay of line voltage. There will be a phase jitter in the gate drive if the reference frequency is not synchronized to the line, but this can be made as small as desired by increasing the reference frequency. A phase locked loop gate drive can lock the reference frequency to the line by means of counters and a phase comparator.

A reference signal gated from a single phase can be used to establish the six gate signals required for a three-phase SCR bridge. Although simple to implement, this may lead to some asymmetry in output if the supply phases are not balanced. The use of three references and three separate drive signals is preferred. All of these phasing systems have the disadvantage of a nonlinear transfer function of control voltage to bridge voltage since the delay angle is proportional

to control voltage, but the bridge output voltage is proportional to the cosine of this angle. However, this relationship can be linearized in software.

The cosine intercept gate drive has an inherently linear transfer function. A line-to-line voltage is integrated and inverted to form a reference voltage, which leads that line-to-line voltage by  $90^\circ$ . Then, a DC command voltage is compared to this voltage and a gate signal generated when the two are equal. The delay angle is the arccosine of the line intercept, and the per unit converter output is the cosine of the delay angle. This circuit provides  $180^\circ$  of phase shift for full range control of a converter. Six of such circuits are generally used for optimum control. Auxiliary circuits can force gate firings to prevent commutation failures in inversion.

Figure 10.18 shows the basics of the cosine intercept gate drive. The power phase shown is integrated and inverted to form a reference phase voltage that leads by  $90^\circ$ . A DC command level then forces a gate firing when the reference phase voltage falls below the command level. Comparators are used to assure operation on the proper portion

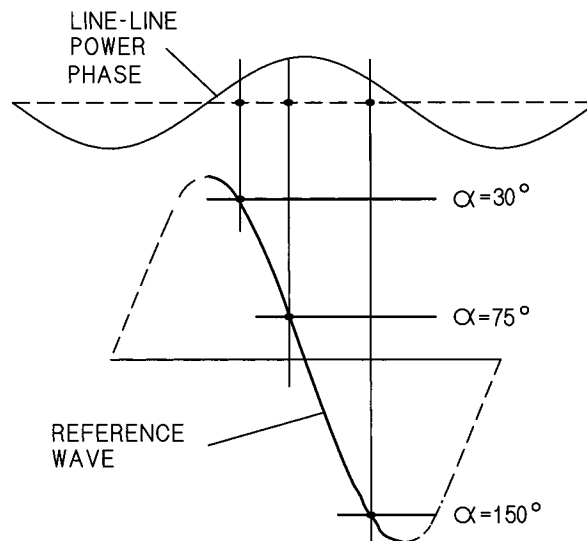

FIGURE 10.18 Cosine intercept SCR gate drive.

of the reference wave. Example DC command levels resulting in delays of  $30^\circ$ ,  $75^\circ$ , and  $150^\circ$  are shown. If the power voltage rises, the reference voltage rises proportionally, and the intercept occurs later in time for a constant command level. Thus, the output voltage is reduced by phase delay as it tends to rise from the source voltage increase. The output is self-compensating and maintains a constant voltage.

Another major advantage of the cosine intercept circuit is that the reference voltage is derived by integrating a line voltage. Thus, a very high degree of noise immunity is obtained. A large noise signal merely results in a minor kink in the response linearity. The cosine intercept gate drive even tolerates commutation notches in the line voltage. This is a distinct advantage over gating systems that require a voltage zero crossing for phase synchronization.

Another system of gate control that was employed on a generator that had to operate over a wide range of speed and frequency was to use a rotary encoder on the generator shaft to establish the internal angle. The terminal voltage for gate control was then synthesized from this angle, the field excitation, machine parameters, and load current.

If the reader will excuse a brief departure from theory, a scene from some years ago may prove amusing. The author's company was negotiating with a potential customer for a large, pulsed SCR converter. The customer was concerned about the ability of the cosine intercept gate drives to cope with a supply voltage that was seriously distorted by other converters on the line. A young engineer in the author's group had set up an impressive demonstration to soothe the concerns of the customer and the customer's consultant. With all the dignitaries present, he threw the switch to power the several converters involved. At that precise moment, a small electrolytic capacitor decided on self-immolation and took off across the lab with a loud bang, trailing an ever-longer spiral tail of aluminum foil. Fortunately, the customer laughed it off, and the order was secured after minor repairs to the demo equipment.

## 10.8. Power to the Gates

Many arrangements have been used to provide the required gate drive power. Low-voltage circuits can use a pulse transformer driven by a fast-rising voltage with a lower voltage sustaining signal to provide direct gate drive. The pulse transformer design must be a compromise between pulse rise time and the sustaining current level. Alternatively, the pulse transformer can be driven by a high-frequency pulse train, each cycle of which has a high-level, fast-rising initial current. The duty cycle on the pulse train should not be less than 50% for most applications. It is difficult to provide the required rise time and sustain current when sufficient insulation is used to operate a high-voltage pulse transformer at line frequency, and a high-frequency supply is commonly used.

Another system provides transformer coupled and rectified DC power for the gate. The source can be either line voltage or a high-frequency voltage. The DC voltage from this power supply is then switched to the SCR gate by a series transistor that is driven by a fiber optic link from a low-voltage gating circuit. A variation of this arrangement is often used for medium-voltage applications. An insulated cable is threaded through the various transformers to form single-turn primaries. Cable current may be on the order of 50 to 100 A at line frequency.

Some SCRs can be gated directly by intense light from a laser with fiber optics providing voltage isolation. Still other SCRs have an integral light-activated pilot SCR that requires a less-intense light source. Gate power is derived from the anode-cathode voltage with capacitor storage. Direct optical gating is now an area of substantial development effort. These matters are further discussed in Chapter 11.

## 10.9. SCR Autotapchangers

An interesting set of SCR systems are grouped under the general name of *autotapchangers*. Basically, they are all methods of control-

ling loads that utilize SCRs to not only change transformer taps but to modulate the voltage between taps for continuous control. They are especially useful for improving the power factor over a simple SCR control and for minimizing the transformer rating for loads that require constant power over a wide voltage range. One example is glass melters, where the desired melting power is constant, but the load resistance varies widely with the glass temperature.

Figure 10.19 shows an AC autotapchanger schematic with a center-tapped transformer secondary. For output voltages up to half maximum, the lower SCR set is phased on from zero to full output, half voltage. Above this voltage, the upper set is gradually phased on to augment the voltage from the lower set. As an upper SCR is gated on, it commutates the lower SCR off and assumes the load current. In the case of a constant power load, the lower transformer winding must be rated for the maximum required current at the lowest operating voltage, whereas the upper winding can be rated for the maximum current at half voltage.

This basic circuitry can be implemented in stacked SCR converters in the same fashion for DC loads. Such an arrangement was used for the MIT Alcator C-MOD Tokamak toroidal field supply some years ago. The magnet required a pulsed 265-kA operating current but also required the fastest possible rise time to this current and subsequent

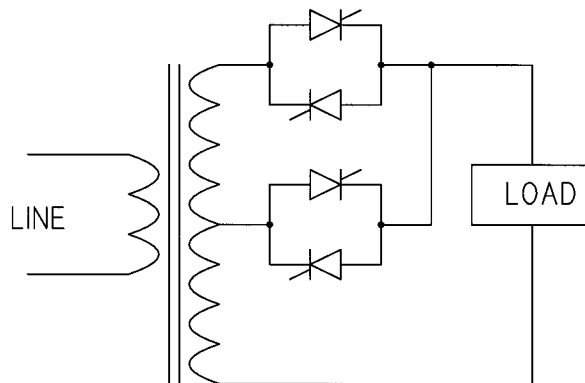

FIGURE 10.19 SCR autotapchanger.



fall. Yet the kVA available from the source generator was limited to 250 MVA. An autotapchanging set of converters allowed the system to operate on the high-voltage converter at 1500 Vdc at low currents and gradually phase back the high-voltage converter with increasing current until the low-voltage converter supplied the full load current at 900 Vdc. This arrangement satisfied the required rise time while minimizing the end turn stresses on the generator. The low-voltage tap had 6 parallel SCR paths, and the high-voltage tap had 4 parallel paths in each of 8 converters, for 480 SCRs in all.

The power factor benefit of an autotapchanger is shown in Fig. 10.20. Here, a controlled DC output voltage is shown with and without a 2:1 voltage ratio autotapchanging converter set. If a constant power load is required, the reduction in var demand is even more impressive. The low-voltage bridge conducts at a linearly increasing power factor until unity power factor is reached at half voltage. The power factor then decreases somewhat as the high-voltage bridge is phased on with increasing voltage, but it then rises again to unity at full voltage.

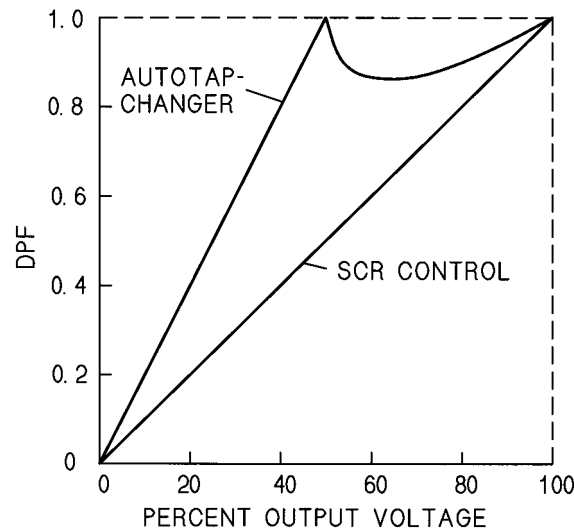

FIGURE 10.20 Displacement power factors.

### 10.10. SCR DC Motor Drives

DC motor drives were an early application of phase-controlled converters. Regeneration can be obtained with a single bridge converter and a polarity-reversing field system. However, the response time is poor and unsuited to the requirements for rapid regeneration and reversing in steel mill roll drives. The use of two bridges in an inverse parallel connection allows full reversing and regeneration by means of armature control. If the bridges are directly paralleled, one must be disabled at all times to avoid a short circuit. The use of reactors to couple the two bridges allows them to be gated simultaneously with the reactors supporting the differences in their ripple voltages so long as a DC component is not present in both. If one is gated at angle  $\alpha$ , the other is gated slightly behind  $180^\circ - \alpha$ . The schematic for such a dual converter arrangement is shown in Fig. 10.21.

The reactors can be either air core or iron core. This circuit allows a smooth transition between positive and negative motor current, an important attribute for an optimum control loop response.

### 10.11. SCR AC Motor Drives

An early and rugged SCR AC motor drive consisted of an SCR DC converter, a large inductor, and a set of six SCRs in a force-commu-

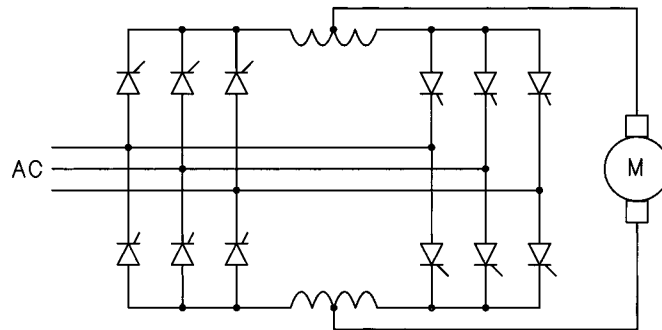

FIGURE 10.21 Reversing, regenerative SCR DC motor drive.

tated inverter. Known as a *current source inverter (CSI)*, it was very tolerant of load faults and could operate over a wide output frequency range. The basic schematic is shown in Fig. 10.22. The converter section operates in a voltage-regulated mode with current limit. The voltage is determined by the load requirement and is usually proportional to the output frequency. The principal objection to the current source inverter is the cost, size, and weight of the inductors and the poor power factor of the input at low output voltages. Also, the converter has a high harmonic current level. Nonetheless, this had been a popular drive in years past.

Another SCR AC motor drive applicable to synchronous motors is the *load-commutated inverter (LCI)*, shown in Fig. 10.23. Here, forced commutations for the SCRs are provided by the voltages developed in the motor from its field excitation. The drive is started by exciting one phase at a time by a very low-frequency series of pulses on the inverter so that the motor is more or less “banged” into rotation, one pole at a time, with discontinuous inverter current. When the armature voltage is high enough to provide commutation current for the SCRs, the inverter reverts to AC drive and accelerates the motor to operating speed. The problems with this drive are, again, the poor power factor and harmonic level on the converter. The transient torques on starting may also be objectionable. Despite the disadvan-

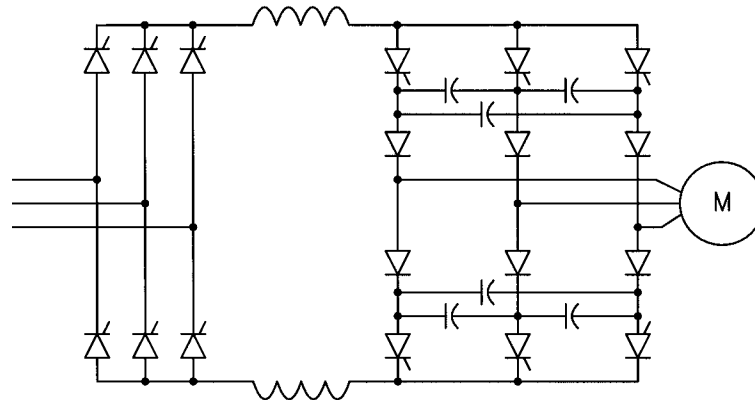

FIGURE 10.22 SCR current source inverter AC drive.

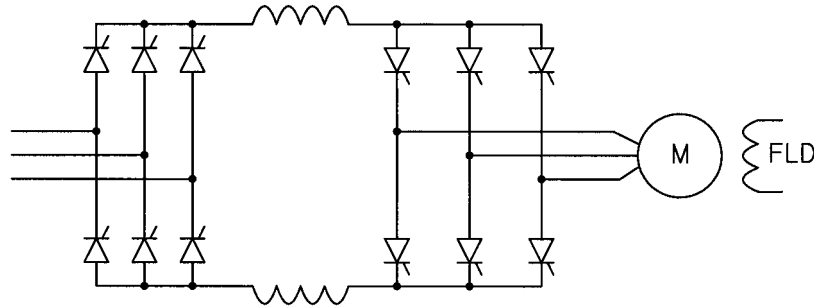

FIGURE 10.23 SCR load-commutated inverter AC drive.

tages of these two drive types, they have been made in large sizes for many years.

### 10.12. Cycloconverters

If the SCR dual-converter DC motor drive is driven with a low-frequency AC signal, it will faithfully produce a cyclically reversing output. Except for washing machines, however, such a motor drive would be of little use. But the ability of the dual converter to act as a frequency changer gives rise to a host of applications. The circuit of Fig. 10.23 can be used as is to produce an AC output frequency as high as 25 Hz. Three such units can be powered from a common 60-Hz supply bus to produce three-phase, 25 Hz with isolated transformer primaries replacing the DC machine. The gate drives are a set of three 25-Hz signals that are phase locked to a common reference with  $120^\circ$  phase shifts.

Although the three-phase cycloconverter requires 36 SCRs, it is a simple, rugged frequency changer with a number of important attributes. When used to provide a common bus for a 25-Hz system, it can supply high overload currents to allow selective tripping of protective relays and sufficient overload current to enable across-the-line starting of large induction motors. It can provide variable-frequency power to a six-lead, three-phase induction or synchronous motor for

speed control. Since this arrangement requires no supply or output transformer, it is a lightweight, high-efficiency system that is becoming popular for marine propulsion on both cruise ships and military vessels.

The cycloconverter can also be used as an asynchronous intertie between two power systems of different frequencies or between interconnected power systems of the same frequency. In the latter case, it can exchange power with no concern about the relative phase angles of the two sources and thereby be of material value in maintaining system stability. Its inherent ability to transfer power in either direction is also important. The author had the pleasure (admittedly with some trepidation) of interconnecting the 60-Hz and 25-Hz systems of the Niagara Mohawk utility with a little 2000-kVA cycloconverter designed for the coke works of Bethlehem Steel in Lackawanna, NY. The Niagara Mohawk system had several hundred megawatts capacity on the 25-Hz system and several thousand megawatts on the 60-Hz system. All went well with controlled power flow in either direction. A duplicate cycloconverter had been built for the tin line of J&L Steel, in Aliquippa, PA, to serve as a source for the 25-Hz plant bus. The little unit saved the considerable expense of running a 35,000-hp frequency changer set at light load. Yet another identical unit drove a pump at a nominal 23.5 Hz to supply water for the city of Aliquippa.

The down side of the cycloconverter is that there is no isolation between the input and output circuits. The input power line has a set of harmonic currents bearing the usual signature of the input converter plus a rich set of spurious frequencies resulting from intermodulation products of line and load frequencies. The intermodulation spectrum of a variable-frequency cycloconverter drive varies with the output frequency, so it becomes difficult to attenuate without an active filter. The output voltage also has a high harmonic output because of the chopped approximation to a sine wave.

The other disadvantage of the cycloconverter is that it operates at a very poor average power factor and may require considerable correction. The power factor varies from a relatively high value to zero over

the output sine wave. This may be of little moment on a dedicated system, but cycloconverters operating from utility lines will probably have to be power factor corrected to avoid serious power factor penalties on the demand charges. Because of the high harmonic content of the line current, power factor correction capacitors will likely need series inductors to prevent them from sinking excessive harmonic currents. This subject is further addressed in Chapter 15.

## Chapter 11

---

---

# Series and Parallel Operation

No matter how large SCRs and their relatives may become, there will always be a need for operating devices in series and/or parallel to meet the requirements of high-voltage DC (HVDC) systems, var compensators, and *flexible AC transmission system (FACTS)* devices. The design objective is to provide good sharing of the voltage in series operation and the current in parallel operation. Neither is trivial. SCRs have been chosen to illustrate the techniques, but other semiconductors will have similar requirements.

### 11.1. Voltage Sharing

Series operation of SCRs requires the SCRs to share equally the applied voltages under all conditions of use. There are four distinct regions of operation for an SCR: turn-on, forward conduction, turn-off, and quiescent operation with either forward or reverse voltage. In a series stack of SCRs, the slowest device will have a disproportionate share of the overall voltage prior to its turn-on, since its partners will already be on. Therefore, it is necessary to turn on each SCR as quickly as possible with simultaneous gating signals having fast rise times to some 3 to 5 A in less than 500 ns. In nearly all situations of

SCR gating currents, more, higher, and faster are all better. The driving voltage is typically 20 to 40 V open circuit with current limiting.

Figure 11.1 repeats Fig. 10.2 to show a typical gate drive suitable for series operation. If the series gates are fired from fiber optics, the dispersion times of the various emitters and detectors in the fiber optic chains must be minimized.

A number of systems have been devised to fire a series of SCR gates. Figure 11.2 shows several arrangements of firing conventional SCRs in series stacks. At left, a high-voltage insulated cable is threaded through a series of toroidal current transformers with secondaries wound to support several tens of volts. The primary cable will circulate a typical current of 100 A or so at 60 Hz to provide power at the gate level. The gates are fired by fiber optics. This has been a popular arrangement for medium-voltage var compensators. The center sketch shows individual power transformers providing power at the gates. Again, the gate firing is through fiber optics. A variation on this arrangement utilizes a high-frequency supply to reduce the size of the transformers. At right, a pulse drive system drives all gates through pulse transformers. Although this has been used successfully on medium-voltage systems, the transformers require careful design and testing to meet insulation, rise time, and sustain requirements. Another arrangement utilizes a number of sec-

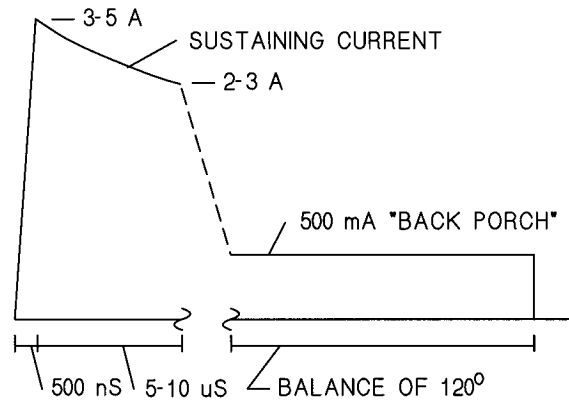

FIGURE 11.1 High-level gate drive.



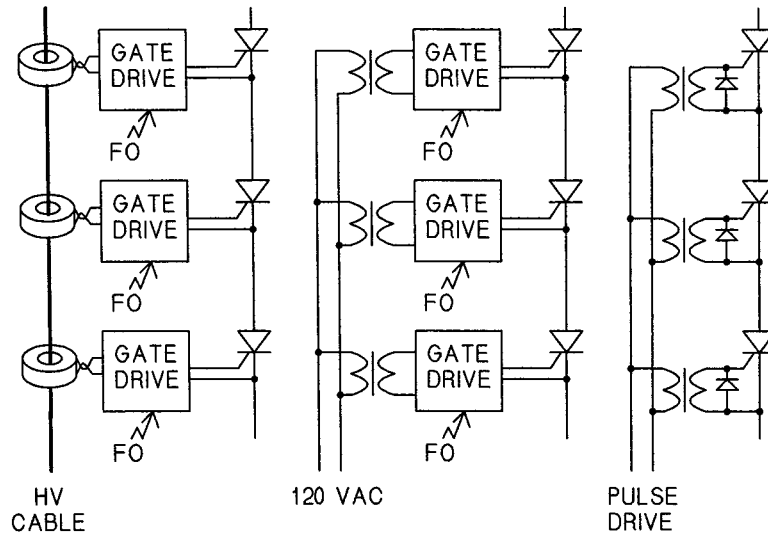

FIGURE 11.2 Series SCR gate drive arrangements.

ondaries on a single pulse transformer and has been employed successfully on 5-kV class equipment. Most of these arrangements use a pulse train instead of a single gating pulse per cycle.

Yet another arrangement for gate power, shown in elementary form in Fig. 11.3, is applicable for the highest voltages. Here, the power for a gate is derived from the anode-cathode voltage of that SCR. This requires a small delay in gating so the system can charge but, when charged, it can supply two gate pulses  $60^\circ$  apart each cycle. It cannot sustain a high-level gate drive without excessive network dissipation. This basic gating scheme is used on HVDC systems.

In addition to the electrically fired gates, two versions of SCRs are fired directly from light. Some large SCRs have optically sensitive gates that fire on receipt of a high-level laser beam. Others utilize a pilot gate fired from a lower powered laser. This is an area of device development at present.

The gating techniques above cover the required turn-on symmetry for series operation. SCR recovery is somewhat more complicated. The recovery waveform of Fig. 10.2 can be extended as in Fig. 11.4 to

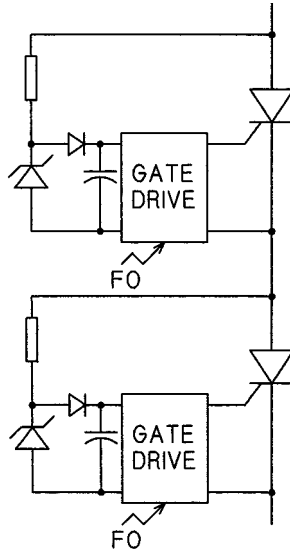

FIGURE 11.3 Anode-cathode derived gating.

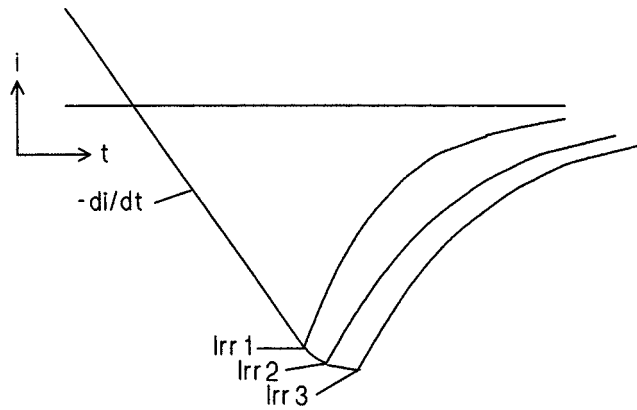

FIGURE 11.4 Series SCR recovery characteristics.

show the inherent recoveries of three series devices. SCR 1 starts to recover first and, as it begins to support voltage, the circuit voltage driving  $di/dt$  decreases, and the recovery of SCR 2 and SCR 3 slows. SCR 1 will have a disproportionate share of the source voltage, because the others are still conducting reverse current. It is possible to

match the recovery characteristics of the SCRs, but it is still necessary to force a better sharing, because the match will be affected by temperature and the circuit  $di/dt$ . The equations of Fig. 10.4 can be extended to the series devices with individual SCR characteristics used to determine the unbalance in reverse voltages.

The standard technique for forcing voltage sharing during recovery is to add an R/C network across each SCR. The time constant of the R/C network in Fig. 11.5 is made comparable to the recovery time of the SCRs. If the SCRs are matched in sets by recovery charge and current, the schematic of Fig. 10.4 can be extended to a series circuit that represents the worst-case unbalances and yields the recovery voltage for each SCR characteristic. The worst case is usually one fast-recovery (low peak recovery current and low recovered charge) SCR in series with a number of slower devices.

The R/C network does nothing to aid the voltage sharing during the periods in which the SCRs are just sitting with forward or reverse voltage applied. The time constant of R/C is so short that differences in voltage simply charge the capacitor. Resistor R2 is used to swamp out the differences in forward and reverse leakage for the SCRs. It should draw 5 to 10 times the leakage current, depending on the degree of balance required. Resistor R1 must be a noninductive type, but R2 does not have to be. Snubber design should be examined with a computer program as in Fig. 11.4 to determine resistor and SCR losses.

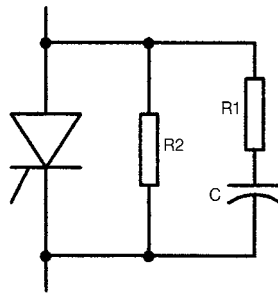

FIGURE 11.5 Sharing network for series SCRs.

## 11.2. Current Sharing

Current sharing is very simple. Merely insert enough resistance in each SCR circuit to swamp out the variations in forward drop. This works fine in pulsed converters for magnetic fusion research in which stainless steel or monel tubing is used to obtain several volts of drop at full current. Unfortunately, the power loss is so high that this cannot be used except for pulsed converters where the duty cycle is very low.

Current sharing in continuously rated converters requires SCRs matched in forward drop and particular attention to balancing the self and mutual inductances in each path. Figure 11.6 shows several bus arrangements that show balance and unbalance.

At A, the current in SCR 1 will be greater than in SCR 2, because both the inductances and resistances are lower. SCR 2 has the added 1–2 paths. The situation can be corrected by using layouts B, C, or D, all of which have balanced inductances and resistances. At E, SCR 2 gets the highest current, because both SCR 1 and SCR 3 have higher inductance and resistance. The situation can be corrected by offsetting the connection points as in F so that the resistances and inductances from each SCR to the bus are the same. G illustrates an interesting problem, because mutual inductances now come into play. If the spacing between the entry and exit buses and the paralleling bus is small,

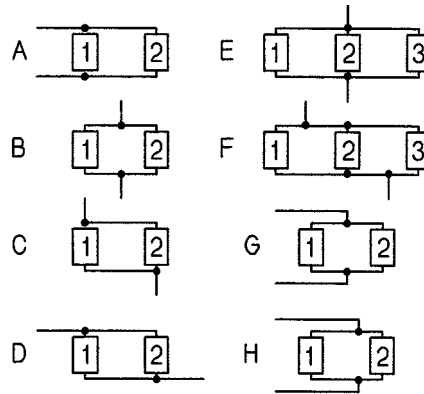

FIGURE 11.6 Bus layouts.

there is little mutual inductance to SCR 2. SCR 1, however, is coupled to the entry and exit buses that are carrying double current in the opposite direction from SCR 1 and therefore induce voltages that subtract from the resistive and self-inductance drops. It may be possible to offset the entry and exit bus attachment points, but there is no assurance this will work. Even if the entry and exit points are at SCR 2, the current may still be greater in SCR 1. Then, the solution must be to rearrange the bus or increase the spacing of the buses.

Figure 11.7 illustrates the process. A is an entry bus, and B + C is a connection bus to two SCRs represented by the dots. The self-inductances of lengths B and C may be calculated from the usual formulae based on the bus dimensions and lengths. The mutual inductance from A to B is approximately  $M_{AB} = M_A - M_{A-B}$  where  $M_A$  and  $M_{A-B}$  are the mutuals between the conductors for length A and length A-B, respectively, with spacing S. If the self-inductance of length B is  $L_B$ , then the equivalent inductance of length B is  $L_T = L_B - 2M_{AB}$ . The current is twice as high in A as in B, and it is in the opposite direction.

It may not be possible to obtain a balance by further offsetting of the connection point if the spacing, S, is small relative to the lengths B and C. The only solution then is increase S or change the bus layout. Note that a small mutual inductance between A and C has been neglected in this analysis. Anytime buses run parallel to each other, the mutual inductances have to be examined for potential problems with current balance.

Canadian General Electric Company and others have used radial symmetry to obtain balance. The entry and exit buses are at the center of a hub arrangement with the SCRs at the ends of radial bus links. By

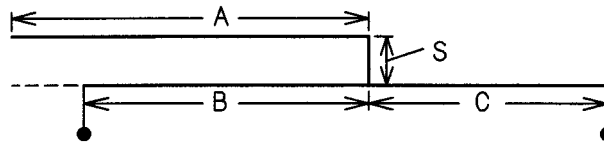

FIGURE 11.7 Self and mutual inductances.

using SCRs matched for forward drop, excellent current balance is obtained.

### 11.3. Forced Sharing

It is possible to use an inductor in each leg of a set of paralleled SCRs to create enough voltage drop to offset the unbalances. This arrangement has been used on DC motor drives where SCR bridges are mounted in drawers with air-core inductors connecting them to other bridges for paralleling. The inductors improve current sharing and reduce fault currents.

A more popular arrangement for forced sharing is shown in Fig. 11.8. The SCRs are all coupled together with two-winding inductors that force current balance. The inductors must be designed to avoid saturating at the maximum unbalance current for a conducting cycle. The arrangement can be extended to any number of SCRs. This is a relatively foolproof system, but the cost and size of the inductors are not trivial.

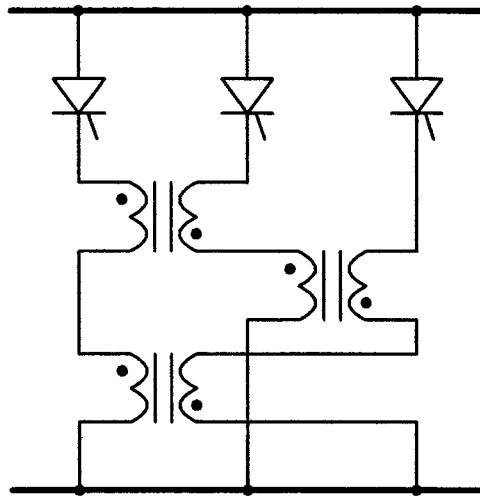

FIGURE 11.8 Sharing reactors.

The gate drive comments made in regard to series operation apply also to paralleling. The first SCR to turn on will tend to steal the anode voltage necessary to turn on the rest and will have a high  $di/dt$ , so the process must take place as evenly as possible. A high-level, fast-rising gate pulse will assure that all SCRs turn on. Again, it is a great kindness to the SCRs to use high-level gating in any application.





## Chapter 12

---

---

# Pulsed Converters

The SCR will probably have a long design life in applications calling for short pulses of high currents. Its ability to latch means it cannot be forced out of a saturated condition by overload, as is the case with the insulated gate bipolar transistors (IGBT). When used as an AC power source, the SCR is able to supply fault currents sufficient to permit selective breaker tripping for minimum system disturbance. The design of high-power pulsed converter systems is an art of its own, and some of the principles are discussed in this chapter. The author has had the privilege of working on a number of fascinating applications in this specialized area.

### 12.1. Protective Devices

Most switchgear items carry a short time rating that must be respected for pulsed service. Protective relays may be inverse-time types to permit carrying high currents for a short time without tripping a breaker. Instantaneous elements must be set above the maximum current, of course. A wide variety of overcurrent relay characteristics is available—inverse, very inverse, and extremely inverse in both short-time and long-time versions. Within a given type, current taps and a time dial allow adjustment over a very wide range of tripping times and

currents. For example, if an extremely inverse-time overcurrent relay is selected to trip a breaker at a given current after a very long time, the breaker will remain closed at 5 times this current for 1 sec, 10 times this current for 0.3 sec, and 40 times this current for 0.1 sec with a particular setting of the time dial. Manufacturer's data sheets provide further information on overcurrent relays.

Fuses are available in a wide variety of characteristics to suit almost any need, from slow-blow glass control fuses to high-speed semiconductor fuses to medium-voltage fuses for motor circuits or transformer protection. Curves are provided that show the melting time/current characteristic and the fault limiting level in the case of semiconductor-type fuses that clear subcycle. In general, fuses should not be operated at pulsed rms currents in excess of about 60% of the melting current for the pulse time. This will assure a long life. Again, the manufacturer's data sheets should be consulted for further information.

## 12.2. Transformers

Transformers generally can be operated well above their thermal ratings for short periods. The limiting factor may be the transient temperature rise although, more often, it will be a limit on electromagnetic forces. Transformers can be designed with bracing of the coils so as to permit repetitive short pulses at more than 15 times the thermal rating. For example, the four transformers built for the Alcator C-MOD tokamak at MIT were designed with cruciform cores, heavy rolled steel cylindrical core surrounds, interleaved round primary and secondary windings, and polyester fiberglass high-strength coil wrappers. Each transformer was rated for 3750 kVA continuous and 58,000 kVA for a pulse that rose to peak current in 2 sec, carried peak current for 1 sec, and dropped to zero in another 2 sec. The pulse repeated every 20 min. These transformers have been in service for some 20 years now and have delivered many thousands of pulses. Similar transformers have been used in various ratings on tokamak supplies at Oak Ridge

National Laboratories (a 300-ms pulse), General Atomic Company, and Princeton Plasma Physics Laboratory. Most are core-style dry types.

A standard transformer can usually be operated at three to five times rated current on a duty cycle that does not exceed the long-time kVA rating. Transformers must be designed to cope with the forces generated by an occasional load fault, so all have the capability to handle a few cycles of, perhaps, 20 times rated current. The catch is that, without special protection and bracing, the lifetime under repetitive pulsed duty may be very short. The forces vary as the square of the current, and there is no sure way to establish a pulsed rating for a standard transformer.

A transformer specification for pulsed service must consider the resistance and leakage reactance. Pulsed converters generally operate at large commutation angles because of the inherently high operating reactance of transformers designed for pulsed service. For example, the MIT transformers cited above were specified for a maximum leakage reactance of 0.02 pu on the thermal base, a very low-reactance design. On the pulse rating, however, the reactance becomes  $0.02 \times 15 = 0.30$  pu. In the absence of commutation overlap, the formula  $E_d = E_{do} - X_{pu}/2$  defines the voltage drop from commutation loss with an inductive load,  $E_d$  being the output voltage at full load,  $E_{do}$  the open circuit voltage, and  $X_{pu}$  the leakage reactance on the pulse rating base. The resistance drop, in effect, subtracts directly from this output voltage. If a very low reactance is specified, the cost increases because the geometry of the transformer will likely depart from the most economical design. Low reactance requires long, thin coils and may require interlacing the windings. On the other hand, a high reactance drop means the no-load voltage must increase to provide the needed full-load voltage. Hence, the kVA rating and cost go up. Furthermore, the commutating angle at zero phase retard and full load is given as  $\cos(u) = 1 - X_{pu}$ . If  $X_{pu}$  exceeds 0.134 for a 12-pulse converter or 0.5 pu for a 6-pulse converter, the commutating angle ( $30^\circ$  or  $60^\circ$ , respectively) is large enough to cause commutation over-

lap between phases and an even greater loss of voltage. Since the specification will define the final cost and performance of the transformer, the various design options should be discussed with the vendor before a specification is finalized.

### 12.3. SCRs

Design considerations for series and parallel operation of SCRs were discussed in Chapter 11. All of these factors apply to SCRs in pulsed service, but there are further considerations for this specialized class of operation, most of which are involved with the conduction losses and junction temperatures. If the forward drop curve for the chosen SCR does not extend to the required peak current, the vendor should be consulted for an extended voltage drop curve. A reasonable approximation can usually be made by fitting a fixed voltage drop and a resistive rise with current to the published curve as far as it goes, and then extrapolating to higher currents. With a forward drop curve in hand, the instantaneous loss can be calculated as  $P = i(t) v(i)$  and then used in the thermal modeling described in Chapter 15. In pulsed service, the switching losses are typically not significant unless the duty cycle is high.

Operating at high pulse currents may require consideration of the turn-on  $di/dt$ . This has been a serious problem in the design of rail guns and similar applications in which the SCRs must switch very high currents. Special SCRs have been designed with highly interdigitated gate structures so as to turn on the entire cathode area as quickly as possible and minimize the turn-on losses. Although the full cathode area may be able to conduct a very high current, the SCR can be destroyed by localized heating in the cathode structure as small conducting areas attempt to cope with very high currents at turn-on. These gate designs are also used on fast recovery SCRs for high-frequency operation where switching losses become important.

Yet another consideration for pulsed service at high currents is that lateral electromagnetic forces in SCR stacks may arise from currents

in adjacent stacks or bus conductors. These may introduce a differential in clamping force across the diameter of “hockey puck” SCRs. As with the considerations above, the vendor should always be consulted on any application that strays from the published data sheet.



## Chapter 13

---

---

# Switchmode Systems

Early DC generators employed an excitation system that was controlled by a “tick-tock” regulator. If the generator voltage fell below the regulated value, the excitation was switched on until it was back to normal. Then, the excitation was switched off again, and the field current free-wheeled through a shorting contact. The field time constant was long enough that this simple regulator was entirely satisfactory to maintain generator voltage within a narrow band. Until transistors came along, such a simple system regulated the voltage for the instrument cluster in an automobile, and one could occasionally see a slight flicker in the dash lights of old cars. The DC generators in autos also were current limited by an on-off regulator. The modern world expects more than most simple on-off regulators can deliver, and the basic principles have segued into sophisticated pulse width modulated power electronics systems where the on-off operation is completely transparent to the user.

### 13.1. Pulse Width Modulation

If the DC supply shown in Fig. 13.1 can be switched rapidly on and off, the load waveforms will be those shown. A continuously variable average voltage from (nearly) zero to (nearly) the full supply voltage

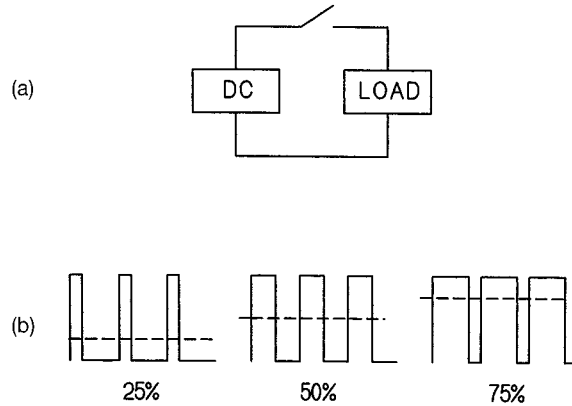

FIGURE 13.1 Basic pulse width modulation.

is available by changing the duty cycle of the switching. The “nearly” has to be added, because switching devices in the real world have minimum on times that produce a small output and minimum off times that prevent them from reaching full output voltage in a controlled manner. They can be switched completely on or completely off, but small prohibited areas of control always exist near those extremes.

The limitations imposed by the need for AC line voltage or forced commutation in SCRs limited their applications in pulse width modulated systems, and they spurred the development of SCR derivatives that could be turned off by a control signal. The SCR morphed in one direction into the *gate turnoff thyristor (GTO)*. This device can be turned off by a gate signal with a very high peak power but a small average power. The GTO is available in high-current and high-voltage ratings and has found niche applications where its characteristics are favorable. But it remains very expensive, and it cannot be classed as a general-purpose industrial control device at this time.

Another SCR derivative is the *integrated gate controlled thyristor (IGCT)*. The IGCT can interrupt anode current by having a current larger than the anode current injected into the gate. It requires a very low inductance in the gate circuit to create a current equal to the anode current with a low-voltage supply, and that mandates incorpo-



rating the gate driver into the physical packaging of the IGCT. The required energy storage for the gate signal is aided by the use of “supercaps,” low-voltage electrolytic capacitors with a very high energy density. Again, the device is not really suitable for general-purpose use, although it has been used successfully in high-power applications. Both the GTO and the IGCT are somewhat handicapped by the regenerative, latching characteristic of the parent SCR. They do not cease conduction gracefully but must be driven out from the gate.

Developments on power transistors continued through the years and resulted in a breakthrough when a field effect transistor was wedded to a conventional bipolar transistor. The result, the *integrated gate bipolar transistor (IGBT)*, is rapidly becoming the device of choice for many applications. It has engendered a host of new high-power equipment designs featuring switchmode operation. The device has the ability to operate at frequencies several orders of magnitude higher than the SCR, although the higher-power IGBTs are more limited in their maximum frequency.

The IGBT has a PNP power transistor controlled by a field effect transistor such that it has the best properties of each. It can handle very high powers and yet be controlled by a gate that, being insulated and field controlled, draws no current. Figure 13.2 shows the collector-emitter voltage as a function of the collector current for several different gate-emitter voltages. As the gate voltage is increased, the IGBT begins to draw current, and this current increases with collector voltage until a region is reached at which the current is constant for a given gate voltage. At high levels of gate voltage, however, a saturated region is reached in which the collector-emitter voltage varies only slightly with collector current. Although the IGBT can be operated as a linear amplifier in the same manner as a transistor, it is almost always operated as a switch between off and on with enough gate drive so it remains at the lowest possible voltage drop for the required current. The saturated voltage drop is typically in the 3.0-V range. IGBTs are currently available in voltages to 6000 V and currents to 2000 A. Most large IGBTs are packaged in a molded plastic assembly

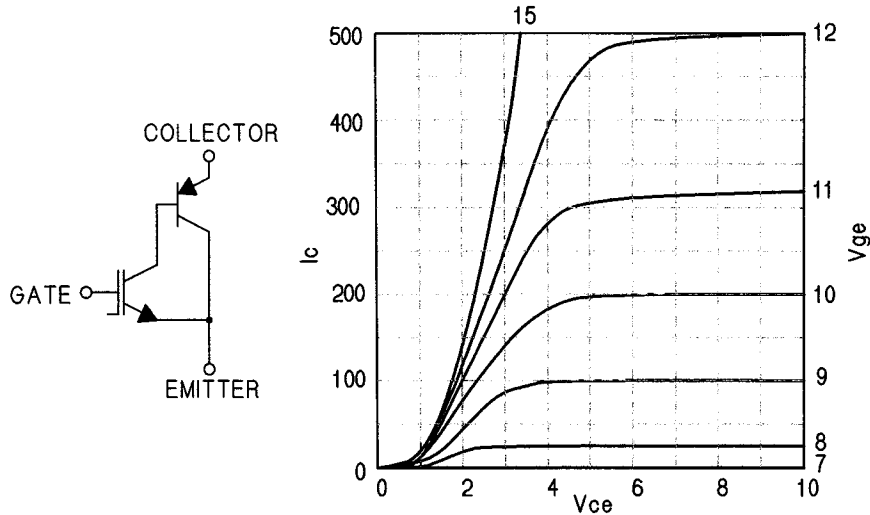

FIGURE 13.2 IGBT schematic and characteristics.

on an integral mounting plate that serves as a contact medium to a heat sink. The active device itself consists of a large number of small IGBTs connected in parallel with bond wires to the external electrodes. Many have an integral inverse parallel diode.

External circuitry for the IGBT must recognize the fast switching characteristics of the device. Turn-off time can be as little as 500 ns and, with collector currents as high as several thousand amperes, the circuit  $di/dt$  can reach fearsome levels. It is imperative that stray inductances in snubber circuits be kept to an absolute minimum to protect the device from overvoltage. It is also necessary to prevent excessive load current from pulling the IGBT out of saturation. The dissipation will rise to high levels that can destroy the device in a relatively few microseconds. Yet, immediate cessation of gating may create an excessive  $di/dt$  and an overvoltage on turn-off from faults. The designer must balance the need to limit dissipation with the need for voltage protection by controlling the rate of gate signal turn-off.

Lest one conclude from the above that the IGBT is a fragile device, nothing could be further from the truth. IGBTs have proven themselves as the power conversion elements in AC motor drives over

20,000 hp and in choppers for DC electric arc furnaces at power levels above 100 MW. They are rugged, reliable devices.

### 13.2. Choppers

In Fig. 13.3, an inductor, an IGBT, and a commutating diode have been added to the simple switching system of Fig. 13.1 to form a chopper. When the IGBT is on, the inductor and load current are increased slightly. When it is off, load current circulates through the inductor and diode. The IGBT is always fully on or off. The ripple voltage, exaggerated for illustration, is a function of the operating frequency and the inductance.

There are trade-offs between switching frequency and dissipation in the switch. A low operating frequency leads to more ripple in the out-

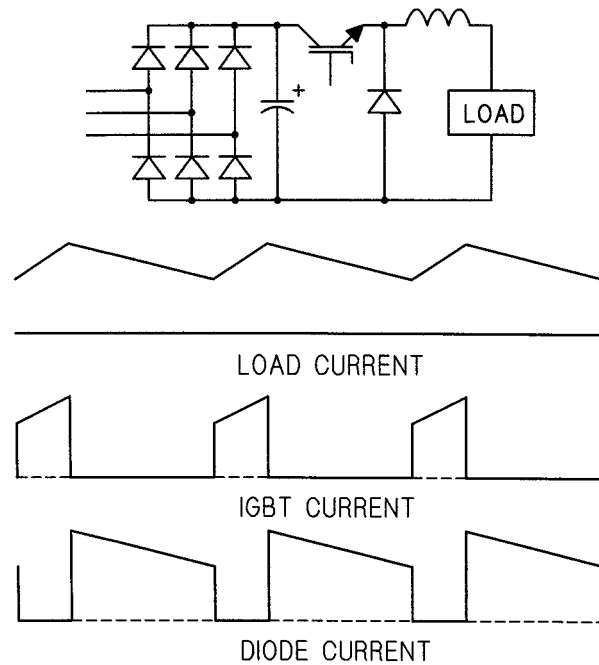

FIGURE 13.3 Chopper circuit and waveforms.

put, but switch losses are proportional to the operating frequency as well as the switched current. These circuits can be replicated almost without limit to accommodate any needed power level. Phase shifting transformers are often used with a set of choppers on each phase winding. The result is a low distortion current demand from the power line and a low ripple on the output voltage of the paralleled choppers. This modular approach offers a high degree of redundancy for reliability.

An interesting property of paralleled choppers with staggered gating is that the ripple will vanish at certain duty cycles. Figure 13.4 shows the process for three choppers with gating staggered by  $120^\circ$ . At a 50% duty cycle, the ripple is reduced to one-third but, at 33% duty cycle, the ripple vanishes identically.

To all intents and purposes, the chopper is a dc transformer. Figure 13.5 shows the voltage and current relationships between input and output for a basic chopper operating with a 50% duty cycle for an output voltage half of the 100-V input. It is the equivalent of a 2:1 stepdown transformer.

### 13.3. Boost Converters

The chopper circuit is, as mentioned, basically a DC stepdown transformer. Another circuit generally utilizing IGBTs is the boost con-

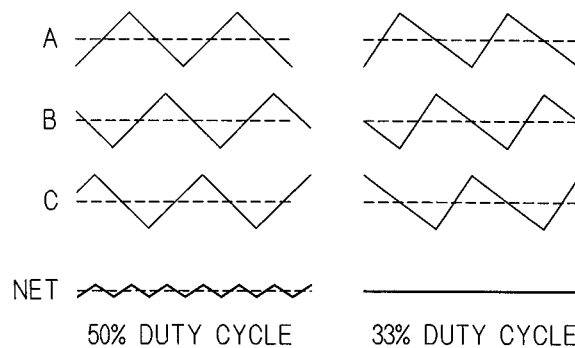

FIGURE 13.4 Ripple in paralleled choppers.

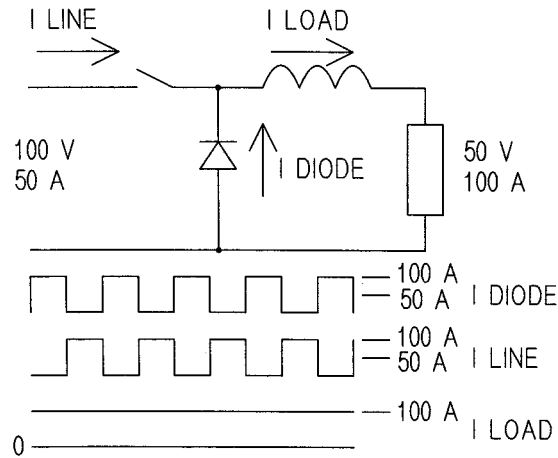

FIGURE 13.5 Chopper at 50% duty cycle.

verter or bootstrap circuit. This circuit has the ability to increase the DC source voltage and to generate high voltage from a low-voltage source. Figure 13.6 shows the basic circuit. When the IGBT is gated, the inductor is charged with current. Then, when the IGBT is turned off, the induced voltage from the inductor  $di/dt$  charges the capacitor to a higher voltage.

### 13.4. The "H" Bridge

Four IGBTs can be combined to form a bipolar switching circuit that is the basis for many motor drives and other applications. Figure 13.7

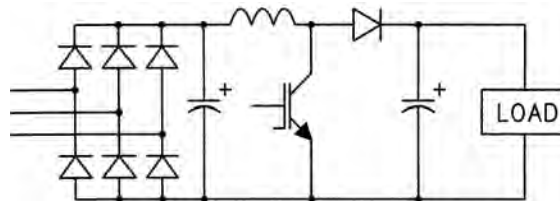

FIGURE 13.6 IGBT boost converter.

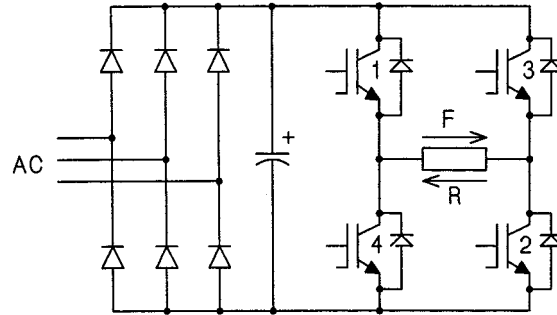

FIGURE 13.7 “H” bridge.

shows the basic H-bridge. The IGBTs are each equipped with an anti-parallel diode that provides a free-wheeling path for load current and clamps any switching transients to the DC buses. If IGBTs 1 and 2 are turned on, load current flows in the direction of arrow F. If 3 and 4 are on, the current flows in direction R. Both polarities can be pulse width modulated to form an AC output waveform. If a sine wave is used as a command waveform, the switching series is shown in Fig. 13.8. The output waveform will be somewhat “ragged,” because the switching frequency is quite low to illustrate the process more clearly. The output waveform is sometimes cleaned up with an output filter to lessen harmonics at the load.

The proper switching protocol is essential to operation of the “H” bridge. If, say, IGBTs 1 and 2 are switched on at the same time that 3 and 4 are switched off, there will be a short circuit because of the turn-

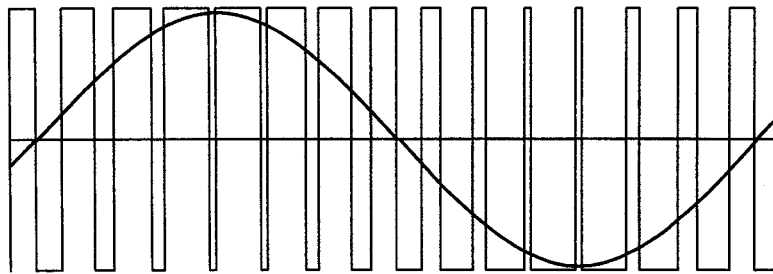

FIGURE 13.8 PWM sine wave switching.

off times of 3 and 4. An “underlap” circuit is necessary to ensure that 3 and 4 are turned off and recovered some time before 1 and 2 are turned on.

One more section can be added to this circuit to form the three-phase motor drive shown schematically in Fig. 13.9.

Many variations on the three-phase circuit have been devised to meet the objectives of lower harmonic distortion at the load, higher voltage output, and a host of other specialized needs. One objection to the basic H-bridge is that the load is switched from peak positive voltage to peak negative, and alternative circuits have been developed to provide lower voltage switching steps to reduce the  $dv/dt$  at the motor. Among these circuits is the neutral-point-clamped inverter, an arrangement that offers five switching voltage levels instead of only two. In addition to the size of the voltage step, the  $dv/dt$  tends to rise with the switching frequency, because the higher-frequency semiconductors switch faster. Motor windings are subject to the front-of-wave effects that were described in Chapter 7 for transformer windings, and the application of solid-state drives to older motors led to problems with insulation failures. Motor manufacturers developed enhanced insulation techniques, and motors are now available that are rated for solid-state drives.

Various types of transistors can be used in the basic H-bridge to operate directly from the AC line and power a high-frequency transformer. Small, lightweight, high-frequency transformers and filters

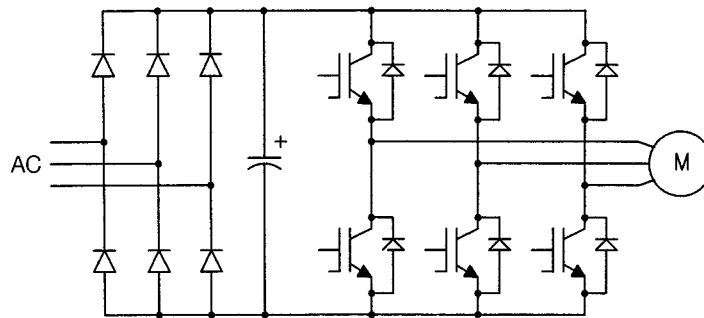

FIGURE 13.9 IGBT motor drive.

have revolutionized the design of DC power supplies for all manner of equipment operated from a 120-Vac line.

Switchmode systems have also penetrated the audio amplifier field. The power output of some of these units in autos just about qualifies them for inclusion in the realm of power electronics, and they are good examples of the differences between switchmode and linear amplifiers. Traditional audio amplifiers have operated vacuum tubes or transistors in a linear region of their characteristics. Power efficiencies, the ratios between output power and input power in the amplifier, were usually between 25 and 60%, depending on the biasing system employed. The difference power was dissipated in the semiconductors. Switchmode amplifiers operate the transistors in either cutoff or saturation so that the losses are dramatically lower. Audio amplifiers must reproduce all frequencies between at least 20 Hz and 20 kHz, so the transistors must be able to switch efficiently at frequencies of 40 kHz or more. The author leaves it to others to decide how much of a contribution to society the rolling boom boxes have made.

### 13.5. High-Frequency Operation

The switching losses in any semiconductor are proportional to the frequency and to some power of the current. If the requirement is to produce or control a certain frequency, the only thing left for control of switching losses is to switch on and off at low currents. And this, of course, precludes utilizing the switching element to control the current. One successful approach is shown in Fig. 13.10. Here, a low-fre-

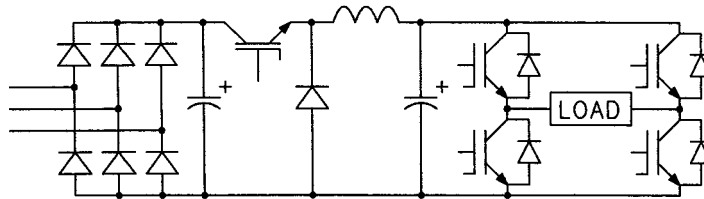

FIGURE 13.10 Chopper-controlled 30-kHz inverter.



quency chopper is used as a current source to a high-frequency IGBT switching circuit that developed some 50 kW at 30 kHz. The IGBT gates were synchronized with the load current so that both turn-on and turn-off were done near zero current points. The IGBT dissipation was dramatically reduced, and zero current switching made the application feasible.

### 13.6. Harmonic Injection

The peak sinusoidal voltage available from a rectifier by an inverter is the DC level minus voltage drops in the inverter IGBTs. Figure 13.11 at left shows the maximum sine wave voltage that can be produced from the DC level shown. At right, a complex wave has been created by adding 15% of an in-phase third harmonic to the commanded sine wave.

This reduces the peak value of the combined wave compared to the sine wave base and, since the combined wave can have the peak value of the DC level, the sine wave base can now be increased by about 15%.  $V_{TOT}$  represents the complex wave,  $V_3$  the harmonic injection, and  $V_1$  the increased value of fundamental sine wave available from the same DC voltage. This scheme is used to advantage in large drives that are made up of series connected inverters to form a line-to-neutral voltage. The third harmonic component vanishes in the line-to-line voltages.

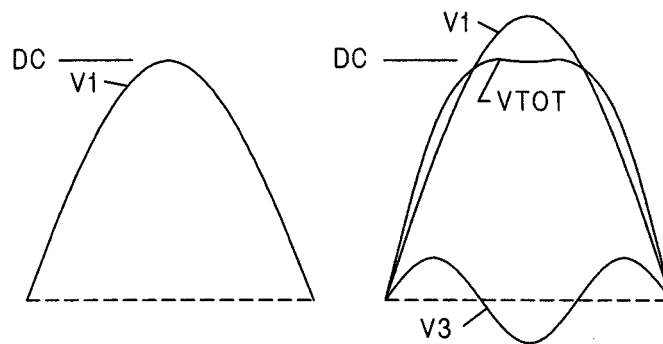

FIGURE 13.11 Harmonic injection.

### 13.7. Series Bridges

One manufacturer has taken the basic three-phase “H” bridge into the medium-voltage motor drive field. The individual bridges are operated from a set of phase-shifted transformer secondaries and are connected in series to produce each line-to-neutral voltage. The phase-shifted windings result in a low harmonic signature in the primary line current, and the series bridges are sequentially gated to produce an output voltage with low distortion. The basic arrangement is shown in Fig. 13.12 for a 2400-V drive. Two sets of windings are phase shifted  $+20^\circ$  and  $-20^\circ$  from the center set to form an 18-pulse input circuit. Three 460-V inverters (A1, A2, and A3) are series connected to form a line-to-neutral voltage for the motor, and two more sets form the other two phases. Despite the apparent complexity of these drives, they are competitive in the marketplace and have been built in output voltages to 7200 V and ratings to 20,000 hp. These drives are a major player in the medium-voltage drive market at this time.

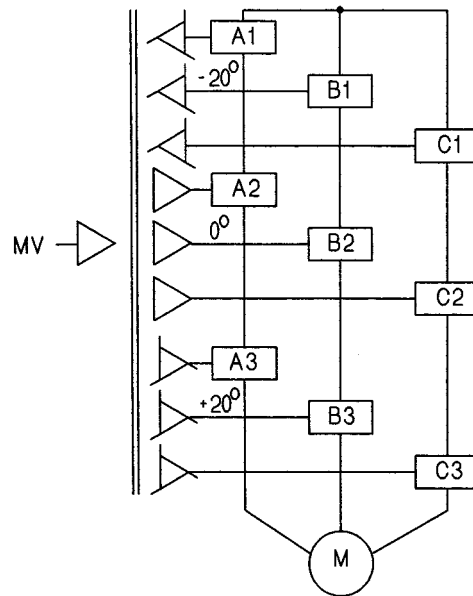

FIGURE 13.12 2400-V, 18-pulse series bridges.

## Chapter 14

---

---

# Power Factor and Harmonics

It may seem odd to treat these two quantities together, but power factor correction in the presence of harmonic currents poses special problems, and correction of harmonic problems may affect the circuit power factor. The two are best considered together so their interactions can be better understood. The author had the pleasure of presenting tutorial sessions on power factor and harmonics for several years at national meetings of the IEEE Industry Applications Society.

### 14.1. Power Factor

Power factor, as everyone knows, is defined as the ratio of real power to volt-amperes and is the cosine of the phase angle between the voltage and current in an AC circuit. These are neatly defined quantities with sinusoidal voltages and currents. Power factor can be improved by adding capacitors on the power line to draw a leading current and supply lagging vars to the system. Power factor correction capacitors can be switched in and out as necessary to maintain var and voltage control.

As mentioned in Chapter 1, many utilities charge industrial customers a certain rate for kilowatt-hours of energy consumed in a month, and another charge related to the infrastructure necessary to supply

that power under the customer's conditions of operation. If the customer is operating with a low power factor load, the demand charge is higher, because the current requirement is higher. Table 14.1 shows the differences between energy and demand.

TABLE 14.1 Energy and Demand

Energy	Demand
Kilowatt-hours from:	Kilovoltamperes from:
Tons of coal	Generators
Acre-feed of water	Transmission lines
Barrels of oil	Transformers
Cubic feet of gas	Switchgear
Ounces of uranium	Distribution systems

Power factor penalties on demand charges range from none to a factor of 2 on the peak power demand. Figure 14.1 shows a power factor demand penalty imposed by one utility. The factor is  $F = 0.8 + 0.6 \text{ kvarh/kWh}$ , but not less than 1 and not more than 2. Typical values for power charges as indicated in Chapter 1 are \$0.03 to \$0.05 cents

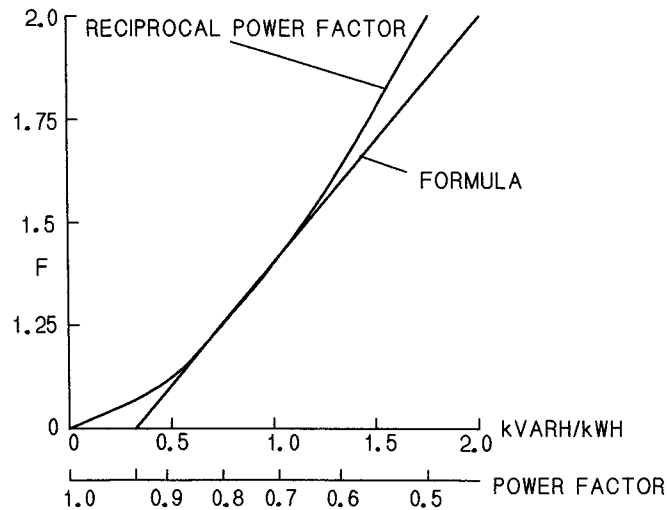

FIGURE 14.1 Demand multiplier.

per kilowatt-hour and \$5.00 to \$15.00 per month per kilowatt-hour of power factor corrected demand.

The pain of a poor power factor can be shown by an example. If a plant utilizes 100,000 kW-h in a month, the energy charge at \$0.04 per kW-h is \$4000. If it has a peak demand of 400 kW during the month, the demand charge at unity power factor with a \$10.00/kW rate is also \$4000. If the power factor is only 0.70, the demand bill goes up to \$5650, a 41% increase. Power factor correction is usually a paying proposition.

Figure 14.2 shows a demand of 400 kW at a power factor of 0.70 as above. The kVA demand is 571 kVA, and the var demand is 408 kvar. If a 300 kvar capacitor bank is added to the supply, the net kvar demand goes down to 108 kvar, demand is now 415 kVA, the power factor is now 0.965, and there is no power factor penalty.

Another benefit of power factor correction is that feeder voltage regulation is improved. Adding capacitors will reduce the quadrature currents, those currents that are 90° out of phase with the line voltage, but overcorrection can cause problems. Many utilities are glad to get capacitors on distribution feeders, especially if they are switched on only during working hours. But some have problems with excessive

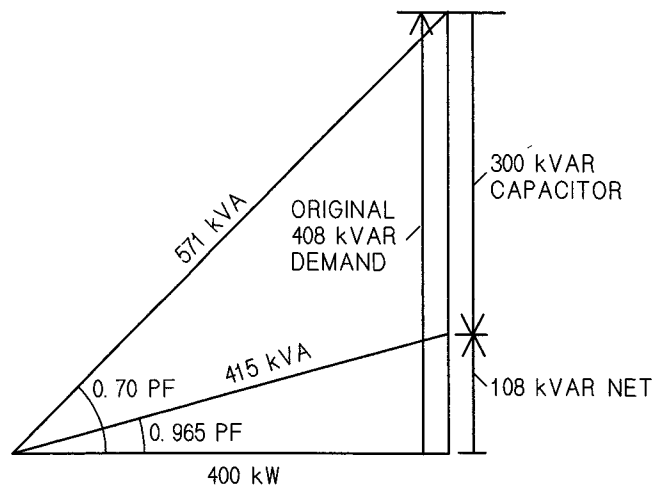

FIGURE 14.2 Power factor correction.

voltage rise during periods of light load, and some may have tariffs that discriminate against leading power factors, too. The same kVA capacity is required for a given leading load power factor as for a lagging one.

Some plant engineers have a pathological fear of a leading power factor for reasons the author could never fathom. In point of fact, no load has any idea what the power factor is and couldn't care less. It has been scientifically proven that leading power factors do not cause illness to machines or humans. The only possible concern for a leading power factor is overvoltage at light load if the power factor goes too far leading.

In a large plant, power factor correction can be applied at the interface between the utility and the customer, the point of *common coupling*, as it is termed. This is generally less expensive than adding a lot of small capacitor banks, particularly when switchgear is required or harmonics are present.

## 14.2. Harmonics

Harmonics are familiar to the musician as the overtones from an instrument. They are the integer multiples of the instrument's fundamental or natural frequency that are produced by a series of standing waves of higher and higher order. The precise mathematical description of this phenomenon creates the equal tempered chromatic scale that is reproduced in Table 14.2.

Exactly the same thing happens in power circuits when nonsinusoidal loads create harmonic currents that are integer multiples of the supply frequency. The rapid growth of solid-state power electronics has greatly increased the number and size of these loads, and the rest of this chapter is devoted to examining their origin, their interactions with the utility, and their control.

A number of nonsinusoidal waveforms were shown in Chapter 6 in conjunction with phase control circuits. The basic mechanism by which harmonics produce nonsinusoidal waveforms is shown in

TABLE 14.2 Equal Tempered Chromatic Scale

Equal Tempered Chromatic Scale					
A3 = 440 Hz					
Note	Frequency	Note	Frequency	Note	Frequency
A2	220.00	A3	440.00	A4	880.00
A#2	233.08	A#3	466.16	A3#	932.32
B2	246.94	B3	493.88	B4	987.77
C3	261.63	C4	523.25	C5	1046.50
C#3	277.18	C#4	554.37	C#5	1108.73
D3	293.66	D4	587.33	D5	1174.66
D#3	311.13	D#4	622.25	D#5	1244.51
E3	329.63	E4	659.26	E5	1318.51
F3	349.23	F4	698.46	F5	1396.91
F3#	369.99	F4#	739.99	F5#	1479.98
G3	392.00	G4	783.99	G5	1567.98
G#3	415.30	G#4	830.61	G#5	1661.22

Each note is related to the next by the 12th root of 2, 1.05946. Thus,  $D4\#(622.25) = D4(587.33) \times 1.05946$ . Each octave note is double the previous octave frequency.

Fig. 14.3. A sinusoidal wave is shown along with its third harmonic at one-third magnitude. The process is reciprocal in that the nonsinusoidal waveform can be resolved into its constituent harmonics by analysis. The upper waveform of Fig. 14.3 shows a third harmonic in phase with the fundamental, a waveform that is a major portion of the squarewave currents characteristic of single-phase converters with inductive loads. The lower waveform shows a third harmonic of the same magnitude that is  $180^\circ$  out of phase with the fundamental, a major component of transformer exciting current.

Transformer exciting current, arc furnaces, SCR drives, rectifiers, and many other loads will produce harmonics in the utility lines. Most

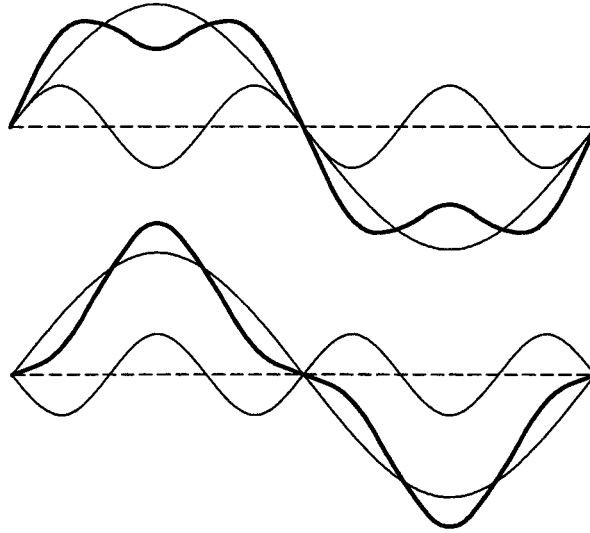

FIGURE 14.3 Fundamental with third harmonic.

utilities limit the allowable harmonic current levels to the values shown in IEEE 519. The levels are functions of the short circuit current available from the feeder compared to the load current, the short circuit ratio, because the primary objective of the limits is to minimize voltage distortion on the feeder to protect other customers. A “stiff” feeder that can source a high short-circuit current will have less voltage distortion from a given harmonic current level than a “skinny” feeder with a low short-circuit ratio.

Three-phase SCR converters with inductive loads draw line currents that are basically  $120^\circ$  square waves. Their phase relationship to the voltage on each phase depends on the angle of phaseback on the SCRs, and they are easy to examine with an SCR DC motor drive. The voltage and current waveforms at left in Fig. 14.4 represent a motor drive at full speed, full voltage. One can eyeball the current waveform and decide that it is in phase with the line-to-neutral voltage, because its fundamental component is in phase. At half speed, half voltage, the SCRs are retarded  $60^\circ$ , and the waveforms are shown at the center. Finally, when the drive is drawing full current at zero



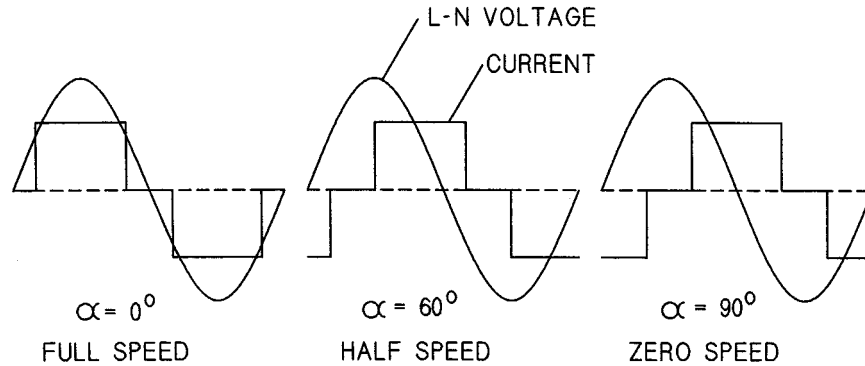

FIGURE 14.4 SCR DC motor drive waveforms.

speed, zero voltage, the waveforms are shown at the right with a  $90^\circ$  phaseback.

If these power factors are considered, things begin to get complicated. It is easy to show mathematically that, with a sinusoidal voltage, the real power involves only the fundamental component of current and its phase relationship to the voltage. Briefly,

$$P = E \times I_{FUND} \cos(\theta)$$

where  $\theta$  is the angle between the voltage and fundamental component of current. Thus, the power is neatly defined with the usual  $\theta$ , and it is fair to assume that  $\cos(\theta)$  is the power factor. But now a problem arises. In calculating the voltamperes, the current contains harmonic components, and its rms value will be larger than the fundamental component. But the angle  $\theta$  was derived from the fundamental component only, and the power will be a smaller part of voltamperes that include harmonics. Yet this is the usual basic definition of power factor, watts divided by voltamperes. The only way out of this problem is to decide that there are really two power factors when harmonics are involved. The usual one is called *true*, *real*, or *apparent* power factor as watts/voltamperes, and the other one is called *displacement* power factor, because it involves the displacement angle between the funda-

mental voltage and the fundamental component of current. The displacement power factor is always higher than the true, real, or apparent power factor. Wattmeters and watthour meters are smart enough to ignore the harmonics in the current and operate on the displacement power factor.

If the DC drive of Fig. 14.4 is operated at constant current, the effects of phaseback on power factor can be plotted. Since the current is constant, and the line voltage is taken as constant, the voltamperes are constant. Figure 14.5 shows that the displacement power factor is proportional to watts and, in turn, speed. These are theoretical curves with no considerations of reactance or losses.

It should be noted that there can be real power in the harmonics if the voltage and current are both distorted. However, the assumption of a sinusoidal line voltage will suffice for most supply calculations in power electronics.

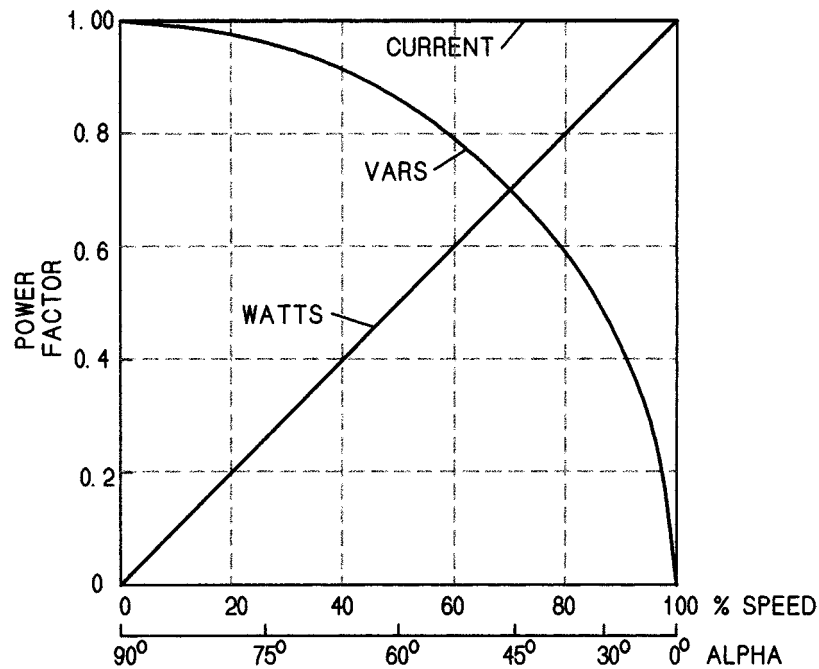

FIGURE 14.5 SCR DC motor drive characteristics.

### 14.3. Fourier Transforms

The most general transforms for an arbitrary function of time create a continuum of frequency components in the complex plane. These transforms, shown in Fig. 14.6, can be applied to aperiodic functions to determine their frequency spectra, and the complex operator,  $s$ , can be replaced by  $j\omega$  for this purpose. Integration in the complex plane can be accomplished numerically with the integration carried out to the maximum frequency of interest.

Several simple examples will be used to show the general behavior of these integrals. The first, at left in Fig. 14.7, is a pulse of unit area in the time domain. At center, the pulse is greater in amplitude but still of unit area. At right, the amplitude is infinite but the area is still a unit value. The figure at right is interesting, because it shows that a unit pulse of zero width contains equal magnitudes of all frequencies.

In 1822, the French mathematician, J. B. J. Fourier, showed in a paper on heat conduction that any periodic function could be resolved into a fundamental component at the repetition frequency and a series

$$F(s) = \int_{-\infty}^{\infty} f(t)e^{-st} dt$$

$$f(t) = \int_{-\infty}^{\infty} F(s)e^{st} dt$$

FIGURE 14.6 Transforms in the complex plane.

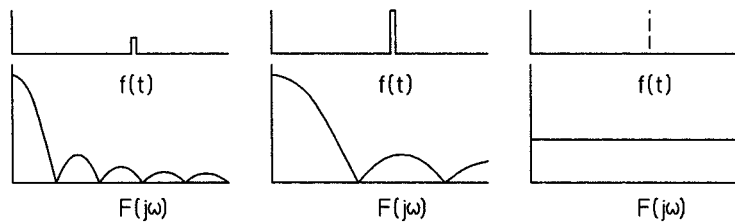

FIGURE 14.7 Transforms of pulses.

of integral harmonics of that frequency, each with a particular amplitude and phase relationship to the fundamental. The series Fourier developed is shown in Fig. 14.8.  $A_0$  represents a DC component, while  $A_n$  and  $B_n$  represent the in-phase and out of phase order  $n$  harmonic components of the fundamental  $\sin(x)$ . The function  $f(x)$  is then  $A_0$  plus the sum of all these components as shown.

In the special case of line current waveforms that are symmetrical about  $\pi/2$ ,  $f(x)$  from  $\pi$  to  $2\pi = -f(x)$  from  $0$  to  $\pi$ , and there is no DC component—the Fourier transforms reduce to the single simple form shown in Fig. 14.9. The harmonics are all sine waves, either in phase

$$A_0 = \frac{1}{2\pi} \int_0^{2\pi} f(x) dx$$

$$A_n = \frac{1}{\pi} \int_0^{2\pi} f(x) \sin(nx) dx$$

$$B_n = \frac{1}{\pi} \int_0^{2\pi} f(x) \cos(nx) dx$$

$$|H_n| = (A_n^2 + B_n^2)^{1/2}$$

$$\Theta_n = \tan^{-1}\left(\frac{B_n}{A_n}\right)$$

$$f(x) = A_0 + \sum_1^{\infty} \left(\frac{A_n}{B_n}\right)$$

FIGURE 14.8 Fourier transforms.

$$H_n = \frac{2}{\pi} \int_0^{\pi} f(x) \sin(nx) dx$$

$$n = 1, 3, 5, 7 \dots$$

FIGURE 14.9 Fourier transform for a symmetrical waveform.

with the fundamental or  $180^\circ$  out of phase. Many power electronics waveforms of power line current can be approximated in this fashion.

If these transforms are applied to the  $120^\circ$  square wave, the harmonics turn out to be a series of order  $h = 6n \pm 1$ , where  $n$  takes on all integer values. The amplitude of each harmonic,  $h$ , relative to the fundamental is equal to  $1/h$ . The fundamental itself has a peak amplitude relative to the square wave of 1.10.

The Fourier transforms will yield the peak values of each harmonic but, since all are sine waves, the rms values are simply  $\text{peak}/\sqrt{2}$ . The rms of the composite wave is the root sum squares (RSS) value of the fundamental plus all harmonics. Each harmonic is squared and added to the total, and then the square root is extracted.

When dealing with repetitive pulsed functions, it is useful to consider the duty cycle. If the repetitive pulse of Fig. 14.10 has an rms value of  $X$  over the time period  $A$ , the rms value over time period  $B$  is simply  $X\sqrt{A/B}$ . In general, the rms value is proportional to the square root of the duty cycle for a repetitive pulse. Applying this principal to the  $120^\circ$  square wave of unit amplitude, the rms value is  $\sqrt{2/3} = 0.8165$ .

Since the harmonic series for this wave has been developed, it is useful as a sanity check to see if the collection of harmonics adds up to the original wave. Table 14.3 shows the process. As is evident, it works.

Any set of harmonics can be grouped together to define a total harmonic level for comparison purposes. The rms value of a distorted

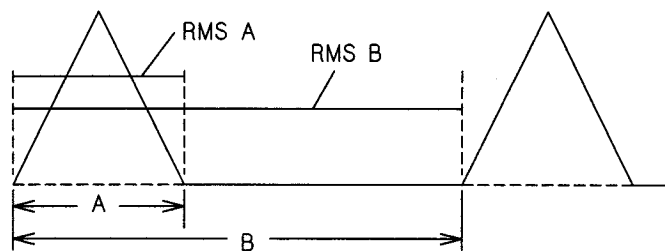

FIGURE 14.10 Duty cycle rms value.

TABLE 14.3 Square Wave RMS Synthesis

120° Square Wave		
Harmonic	Amplitude	Cumulative RSS
1	0.7787	0.7787
5	0.1557	0.7941
7	0.1112	0.8019
11	0.0708	0.8049
13	0.0599	0.8072
17	0.0458	0.8085
19	0.0410	0.8095
...	...	...
$\infty$		0.8165

wave is the RSS sum of the fundamental and all harmonics. This can also be expressed as

$$\text{rms} = \sqrt{h_1^2 + \sum h_n^2}$$

where  $h_1$  is the fundamental, and  $h_n$  is the harmonic of order  $n > 1$ . The summation term can be considered by itself as a distortion term where

$$D = \sqrt{\sum h_n^2}$$

with  $n > 1$ . Then,

$$\text{rms} = \sqrt{\text{Fund}^2 + D^2}$$

and the distortion factor or total harmonic distortion (THD) can be defined as  $D/\text{Fund}$ .

While all this square wave analysis is interesting, it is seldom applicable in the real world. Commutation effects or other processes interfere with infinite rise times, and the 120° square wave is better

represented as a trapezoidal wave or, in the case of a converter, a  $1-\cos(\theta)$  rise and a  $\cos(\theta)$  fall where  $0 \leq \theta \leq u$ . The increase in the square wave rise and fall times “softens” the harmonic series so that the envelope slope of the peak higher order harmonics drops off as  $1/h^2$  instead of the  $1/h$  at low frequencies. These represent slopes of  $-2$  and  $-1$ , respectively when the envelopes are plotted on log-log paper. For typical system reactances, the change in slope occurs somewhere between the 11th and 35th harmonic, the transition frequency being lower as the system reactance and load current increase. The practical effect of this is that the higher harmonics are somewhat less of a problem than one might expect.

While increasing reactance will reduce the higher frequencies, it is not usually a feasible approach to harmonic mitigation. Increasing pulse numbers from phase shifting was discussed in Chapter 7 in regard to transformer connections, and this is generally the preferred method of reducing harmonics. If an SCR converter or a rectifier is supplied from delta and wye transformer windings and the rectified outputs are connected in series or parallel, the result is 12-pulse rectification. The basic harmonic series is now  $h = 12n \pm 1$  instead of  $6n \pm 1$ . The major 5th and 7th harmonic currents are greatly reduced, as are the higher-order ones. Still higher pulse numbers are entirely feasible, and 48-pulse systems are used on large electrochemical supplies. Since large rectifiers and converters require sets of paralleled SCRs or diodes, the additional expense of the phase shifting is primarily a matter of transformer cost. Figure 10.11 illustrates the advantages of a 12-pulse system as compared to a 6-pulse one. Noncharacteristic 12-pulse harmonics are shown at approximately 10% residual level, a typical value. Still higher pulse numbers have characteristic harmonics or order  $h = pn \pm 1$ , where  $p$  is the pulse number.

As a note of interest, a pair of harmonics sets that are simply displaced  $30^\circ$  from each other do not cancel out the sixth-order values. It is the travel of these harmonic currents back through the supply transformer and thereby acquiring another phase shift that makes the cancellation possible.

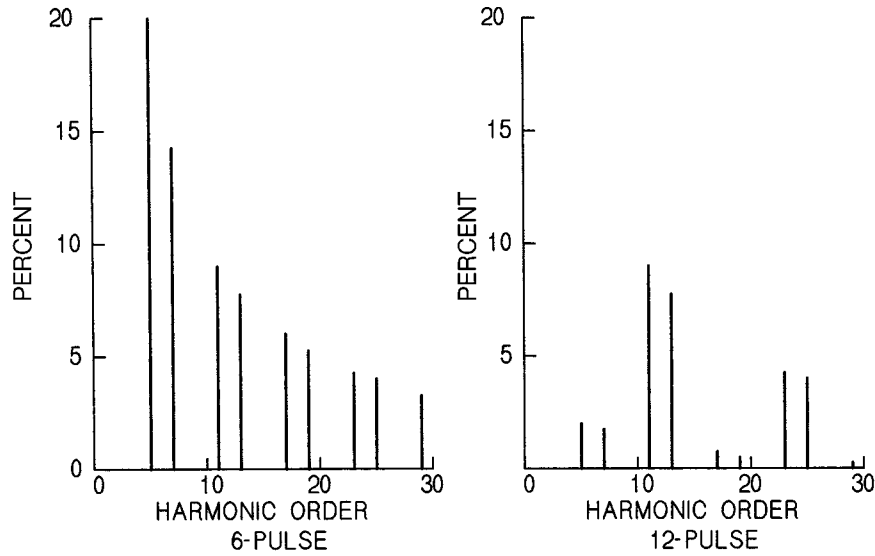

FIGURE 14.11 Six-pulse and 12-pulse harmonic spectra.

The harmonics do not all have the same phase sequence as the fundamental. For a three-phase set of  $120^\circ$  square waves with positive phase sequence, the harmonics alternate in phase sequence  $-5^{\text{th}}$ ,  $+7^{\text{th}}$ ,  $-11^{\text{th}}$ ,  $+13^{\text{th}}$ , and so on. Single-phase components in a three-phase system may arise from unbalances, and these lead to triplen harmonics with zero phase sequence.

Isolation transformers are often considered a panacea for harmonic problems. Such transformers do add some reactance that will reduce the high-order harmonics, but they have no other value except for suppressing zero sequence currents and electrostatic couplings. In general, they accomplish little in the reduction of harmonic currents.

#### 14.4. Interactions with the Utility

Harmonic currents will flow into the utility feeder and may create a number of problems in so doing. They may be trapped by power factor correction capacitors and overload them or cause resonant over-



voltages. They can distort the feeder voltage enough to cause problems in computers, telephone lines, motors, and power supplies, and may even cause transformer failures from eddy current losses.

Most of the voltage effects are rather straightforward, but the interactions with capacitors may be more sinister. The harmonic currents will flow into capacitors and may overload them. However, medium-voltage capacitors are rated for 180% current, so that is not the usual result. Figure 14.12 shows the more serious problem. The harmonics act as current sources and flow both into the utility and into the capacitor, since the utility source inductance appears in parallel with the capacitor. If the frequency of a harmonic current should happen to lie on or close to the resonant  $L/C$  frequency of the source inductance and capacitor, the harmonic current can be greatly magnified by the “ $Q$ ” of the circuit. The result can be serious damage from overcurrent or overvoltage. Such resonances must be avoided.

One nearly foolproof way of handling a resonance is to add an inductor in series with the capacitor so that the sum inductances of the inductor and the source will resonate with the capacitor at a frequency lower than that of any harmonic. However, this approach only prevents resonance problems and does not necessarily alleviate problems with voltage distortion on the feeder. Still, it is widely and successfully used. Some attention must be paid to the capacitor rating, since the presence of the series inductor will raise the capacitor voltage at

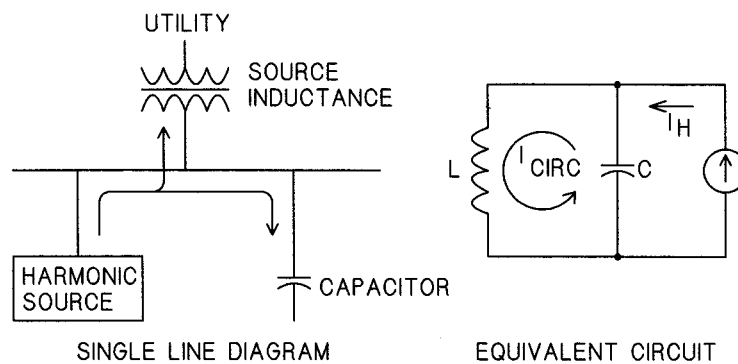

FIGURE 14.12 Harmonic resonance.

power frequency. A 4800-V capacitor may be required on a 4160-V circuit.

The harmonic currents may be trapped by installing series L/C filters resonant at the offending frequencies. These filters should be designed to offer a low impedance at the resonant frequency compared to the source impedance at that frequency. But, again, there is a hidden “gotcha.” If a filter is installed that has a series resonance at the 7th harmonic, it will also have a parallel resonance with the utility at a lower frequency when the source inductance is added to the filter inductance. If this parallel resonance should lie on or near the 5th harmonic, there is the possibility of the resonant overcurrents described earlier. The installation of series resonant traps will always introduce parallel resonances at frequencies below the trap frequencies. Good practice dictates that multiple resonant traps be installed first at the lowest harmonic frequency of concern and then in sequence at the higher-frequency harmonics. If switched, they should be switched on in sequence starting with the lowest frequency trap and switched out in sequence starting from the highest frequency trap.

Installations of series resonant traps should be accompanied by a computer study to see if serious overvoltages result when traps are switched in and out. If a problem is indicated, the transients can be tamed by adding a damping resistor across the inductor. This circuit will be critically damped when  $R = 1/2\sqrt{L/C}$ . Note that this resistance is different from the resistance required to critically damp a series R/L/C circuit, which is  $R = 2\sqrt{L/C}$ . There are many trap arrangements other than the simple shunt traps above. Most are designed to reduce the losses in the damping resistors at power frequency. One popular arrangement is to use two series traps for, say, the 5th and 7th harmonics with a single resistor connected to form an “H.”

The field of power electronics has advanced in recent years to a point where electronic harmonic compensation is economically feasible in some cases. Fast switching semiconductors have permitted control algorithms that can cancel harmonic currents in the source, either

by controlling the conversion system itself or by injecting complex current waveforms to cancel the distortion. Stand-alone systems are economically practical, at this date, for injection currents of several hundred amperes at 600-V class, and the trend is to higher voltages and currents.

Figure 14.13 shows the effect of filter traps on a  $120^\circ$  square wave current with a  $10^\circ$  commutation angle. As the filters are added to remove the harmonics, the waveform becomes less distorted and more nearly sinusoidal. The total harmonic distortion drops from 26 to 6% as the four filters are added.

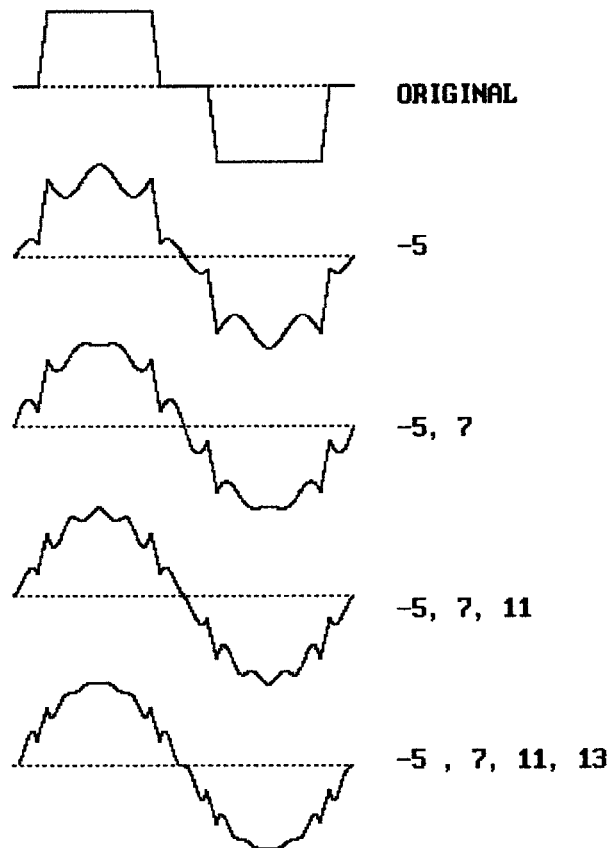

FIGURE 14.13 Harmonic trap results.

The effect of the higher frequencies on voltage distortion may be underestimated. The harmonics drop off as  $1/h$ , but the typical utility source is inductive, so the source impedance is proportional to frequency. The net effect is a nearly constant voltage distortion contribution from each harmonic. The total current distortion can be dramatically reduced by removing a few of the low-frequency harmonics, as Fig. 14.13 shows. But control of voltage distortion usually requires attenuation of many more harmonics. One approach to this is to install a filter that attenuates all frequencies above a certain value. Such a filter is called a *low-pass filter* in the communications industry, but it is a *high-pass filter* in the power industry. The logic for the power industry usage escapes the author, but be that as it may, a typical “high-pass” filter is shown in Fig. 14.14. The basic circuit operates by providing a resistive loading on the harmonics. At low frequencies, the capacitor reactance is high, and the resistor has little effect. But as the frequency rises, the capacitor reactance goes down, the inductive source impedance goes up, and the resistor provides more and more attenuation. The simple circuit at left is seldom practical because of the resistor losses at the power frequency, but the inductor at right minimizes power frequency losses while having little effect on the high-frequency attenuation.

The difference between the effects of 6-pulse harmonics on current and voltage distortion from a  $120^\circ$  square wave is shown in Fig. 14.15. Here, equal amounts of current and voltage distortion are

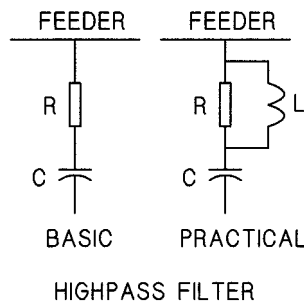

FIGURE 14.14 High-pass filters.

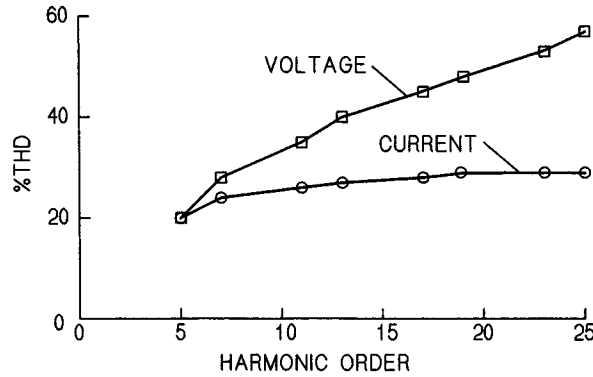

FIGURE 14.15 Current and voltage distortion.

produced by the 5th harmonic. As one adds more current harmonics, the total current harmonic distortion changes little, and it peaks at around 25%. The total voltage distortion produced by these harmonics, however, rises swiftly and is unlimited except for practical considerations. The voltage distortions shown in Fig. 14.15 are much higher than typical but were used to illustrate the point.

### 14.5. Telephone Influence Factor

Harmonic currents on transmission or distribution lines may couple to adjacent telephone lines and cause interference. The potential for interference from a harmonic current to telephone circuits is governed by the *telephone influence factor (TIF)*. This is a value for each harmonic frequency that weighs the probable coupling factor between the circuits, the frequency response of the communication equipment, and the frequency sensitivity of the human ear. These are combined into the “C message weighting” characteristic that defines the interference potential of a given frequency relative to the interference potential of a 1000-Hz signal. When combined with an empirical constant and a coupling coefficient proportional to frequency, the result is a dimensionless weighting curve known as the TIF weighting function,  $W_f$ .

Numerically,  $W_f = 5 P_f I$ , where  $P_f$  is the C message weighting for frequency  $f$ .

The effect of a number of harmonic frequencies is given by

$$\text{TIF} = \frac{[\sum(I_f W_f)^2]^{1/2}}{X_t}$$

where  $X_t$  is the total rms current or voltage,  $X_f$  is the single-frequency rms current or voltage at frequency  $f$ , and  $W_f$  is the single-frequency TIF weighting at frequency  $f$ . The TIF single-frequency values are shown in Table 14.4.

TABLE 14.4 Single-Frequency TIF Values, IEEE 519<sup>a</sup>

Freq.	TIF	Freq.	TIF	Freq.	TIF	Freq.	TIF
60	0.5	1020	5100	1860	7820	3000	9670
180	30	1080	5400	1980	8330	3180	8740
300	225	1140	5630	2100	8830	3300	8090
360	400	1260	6050	2160	9080	3540	6730
420	650	1380	6370	2220	9330	3660	6130
540	1320	1440	6560	2340	9840	3900	4400
660	2260	1500	6680	2460	10340	4020	3700
720	2760	1620	6970	2580	10600	4260	2750
780	3360	1740	7320	2820	10210	4380	2190
900	4350	1800	7570	2940	9820	5000	840
1000	5000						

<sup>a</sup>From IEEE Std. 519-1992, Copyright 1996, by IEEE. All rights reserved.

The interference potential of harmonics can be expressed as the product of the rms current and the TIF as I·TIF, the I·T product. IEEE 519 divides the I·T product into three categories for balanced distribution lines and balanced telephone lines. Category I is I·T products up to 10,000 that are not likely to cause interference, although this value may be as low as 1500 for power or telephone circuits that use a ground return. Category II is I·T products of 10,000 to 25,000 that

may cause interference, and Category III is I-T products greater than 25,000 that are likely to cause interference.

There are no hard and fast rules on interference, and the susceptibility of communications equipment to interference changes over the years. The current edition of IEEE 519 should be consulted for the latest information.

## 14.6. Distortion Limits

Most utilities limit the injection of harmonics into their systems from customers to the values shown in Table 14.5. The limits are expressed as total demand distortion (TDD), the harmonic distortion in percent of maximum demand. Anyone involved with power electronics interfacing to the power line should obtain a copy of the latest version of this specification from the IEEE. The flip side of this coin is the voltage distortion a utility is allowed to supply to customers, shown in Table 14-1 of the same specification. These limits allow 3.0% maximum distortion for any one harmonic and 5.0% total harmonic voltage distortion.

TABLE 14.5 Current Distortion Limits for General Distribution Systems, IEEE 519 (120 through 69,000 V)<sup>a</sup>

Maximum Harmonic Current Distortion in Percent of $I_L$ Individual Harmonic Order (Odd Harmonics)						
$I_{SC}/I_L$	<11	$11 \leq h < 17$	$17 \leq h < 23$	$23 \leq h < 35$	$35 \leq h$	TDD
<20 <sup>b</sup>	4.0	2.0	1.5	0.6	0.3	5.0
20 < 50	7.0	3.5	2.5	1.0	0.5	8.0
50 < 100	10.0	4.5	4.0	1.5	0.7	12.0
100 < 1000	12.0	5.5	5.0	2.0	1.0	15.0
>1000	15.0	7.0	6.0	2.5	1.4	30.0

Even harmonics are limited to 25% of the odd harmonic limits above.

Current distortions that result in a dc offset, e.g., half wave converters, are not allowed.

<sup>a</sup>From IEEE Std. 519-1992, Copyright 1996, by IEEE. All rights reserved.

<sup>b</sup>All power generation equipment is limited to these values of current distortion regardless of actual  $I_{SC}/I_L$ .

$I_{SC}$  = maximum short-circuit current at PCC;  $I_L$  = maximum demand load current (fundamental frequency component) at PCC.

### 14.7. Zero-Switching

Resistance heating systems with a fairly long thermal time constant can be regulated with on-off control. If the control SCRs are switched at zero voltage, the current distortion is very low—but not zero. This has an advantage over a phase-controlled regulator in this respect, but flicker may be a problem. The frequency spectra from zero-switching are rather interesting in that they contain mostly low-frequency components and that, except for the line frequency fundamental component, they are independent of the switching duty cycle. Table 14.6 shows part of the spectra for 1/5 and 4/5 duty cycle switching of integral sine waves. The intermodulation products are caused solely by the discontinuities at the beginnings and ends of the sinusoidal wave sections.

TABLE 14.6 Zero-Switching Spectra

Hz	%I <sub>pk</sub>	
	1/5	4/5
12.0	5.51	5.51
24.0	10.19	10.19
36.0	13.38	13.38
48.0	14.70	14.70
60.0	14.15	56.59
72.0	12.03	12.03
84.0	8.93	8.93
96.0	5.50	5.50
108.0	2.37	2.37
120.0	0.00	0.00
132.0	1.38	1.38
...	...	...
RMS	0.316	0.633



## Chapter 15

---

---

# Thermal Considerations

Many years ago, the author was involved in the design of a small transistor inverter for an early space application. The interesting problem with this unit was that, in the vacuum of space, there is no convection or conduction cooling. All heat must be removed by radiation. Accordingly, the aluminum case was milled with rounded ridges to present the largest possible surface area and radiation normal to the surface at all angles. Since that time, there has been a succession of air and water cooled systems, but that was the only one that relied solely on radiation for cooling.

### 15.1. Heat and Heat Transfer

Some thermal relationships may help put cooling systems in perspective. Table 15.1 covers some of the basics.

Enclosure cooling is by convection and radiation. The several formulae involved can be simplified for rule-of-thumb estimates of heat loss as follows:

$$\text{Radiation} \quad W = 0.00235 Tr^{1.19} \eta \dots$$

$$Tr = (426 \cdot W/\eta)^{0.84}$$

$$\text{Convection (natural)} \quad W = 0.0014 Tr^{1.25}$$

$$Tr = (714 \cdot W)^{0.80}$$

where  $W$  = watts per square inch

$Tr$  = temperature rise in degrees Celsius

$\eta$  = the emissivity

These two formulas are useful from 0 to 50°C, and both are approximations developed by the author.

TABLE 15.1 Thermal Constants

- Specific heat is the ratio of the thermal capacity of a material to that of the same weight of water at 15°C.  $\Delta T = Q/ms$  where  $Q$  is the applied heat,  $m$  is the mass, and  $s$  is the specific heat.
- Thermal conductivity is the time rate of heat transfer by conduction through a unit thickness, across a unit area for a unit difference of temperature.  $\Delta T = Qd/ka$  where  $Q$  is the applied heat,  $d$  is the material thickness,  $k$  is the thermal conductivity, and  $a$  is the area.
- One calorie will raise the temperature of 1 g of water 1°C in 1 sec. One calorie is equivalent to 4.18 Joule. One Joule equals 1 W-sec.
- A heat input of 1000 cal/sec will raise the temperature of a water flow of 1 L/sec by 1°C. A heat input of 1 kW will raise a water flow of 1 gpm by 3.8°C.

**Properties of various materials**

Material	Specific gravity, g/cc	Specific heat, cal/g	Thermal conductivity, cal-g/cm <sup>2</sup> /s/°C
Water	1.00	1.00	1.00
Steel	7.70	0.12	0.11
Aluminum	2.70	0.21	0.50
Copper	8.90	0.09	0.92

The effective radiating surface of a painted object is approximately the area of a sheet stretched around the maximum dimensions. The convecting area of an object is the sum of the areas of sides, ends, and top surfaces. The side areas are not applicable to an enclosure lineup except for the end units. Emissivity of common materials is shown in Table 15.2. As the table shows, paint color matters only for aesthetics.

TABLE 15.2 Radiation Emissivities of Common Materials

Material	Emissivity
Silver, highly polished	0.02
Aluminum, highly polished	0.05
Copper	0.15
Cast iron	0.25
Aluminum paint	0.55
Brass, polished	0.60
Oxidized steel	0.70
Black gloss paint	0.90
White lacquer	0.95
White enamel	0.95
Green paint	0.95
Lampblack	0.95

## 15.2. Air Cooling

Air-cooled heat sink assemblies in the higher power ratings usually require forced airflow. This may take the form of high-velocity fans on the heat sinks or an overall ventilation system, and the two are often combined. It is good practice to equip the heat sinks with thermal switches to detect loss of sufficient airflow. Heat sink fans should be mounted close to the heat sink and, ideally, fans and heat sinks shrouded to confine the airflow. Overall enclosure airflow can be provided by ceiling mounted exhaust fans or by a master air handling system involving a series of enclosures. The latter usually requires a centrifugal fan to provide the necessary pressure, because ducting in cabinets produces relatively high head losses.

Air velocity across heat sinks can be measured by the exhaust airflow with an anemometer. Some anemometers are propeller driven, and others utilize a calibrated thermistor that is cooled by the airflow.

In either case, the average exhaust velocity can be determined by averaging the indicated flows across the heat sink cross section.

Ventilating fans for heat sinks should be chosen carefully. Some fans have blade designs that provide a high airflow capacity at low static head but drop off rapidly with increased head. Other types have a blade design with lesser delivery at low heads but can maintain a good delivery with high head loss. Heat sinks with a multiplicity of closely spaced fins are very efficient, but they have a high head loss and require a suitable fan to deliver the necessary air velocity across the fins. Figure 15.1 shows two typical delivery curves.

### 15.3. Water Cooling

Water cooling of transformers, semiconductors, and buses yields higher outputs for a given size and weight of the equipment. It usually allows more bang for the buck. Unlike air cooling systems, water cooling requires a secondary heat exchange to another cooling medium. Raw water is seldom suitable for electronic equipment

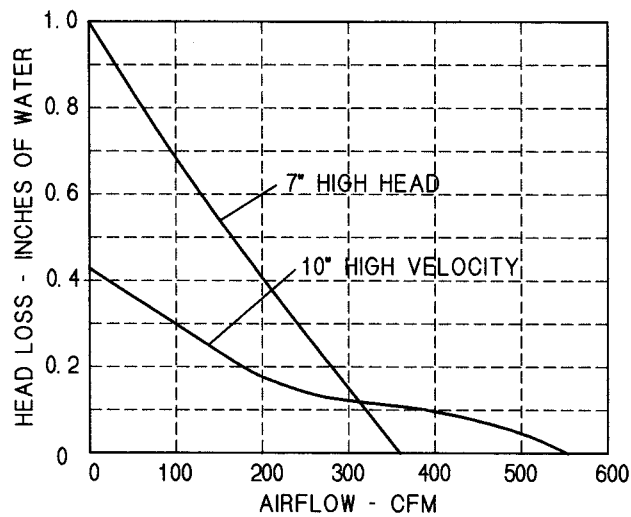

FIGURE 15.1 Fan delivery curves.

because of its high conductivity. Water-cooled heat sinks are widely available for semiconductors and allow high output for both SCRs and IGBTs. Most of the sinks are convoluted in some fashion to assure turbulent water flow, since laminar flow has poor heat transfer. Low-conductivity water can be used when the equipment is always in an ambient above freezing, but more often a glycol solution is required. Chemical grade ethylene glycol was used for many years, but environmental concerns have resulted in a shift to propylene glycol. It is imperative to use a chemical or industrial grade of glycol, because commercial antifreeze liquids often have rust inhibitors and other additives that increase the conductivity.

Figure 15.2 shows a simplified water cooling system. A pump pressurizes an inlet manifold that may feed cooling paths for semiconductors, transformer windings, and bus and cabinet coolers. The various paths are controlled by throttling valves that allow for adjustment of the water flow and can isolate the path to permit repairs. The outlet manifold passes through a heat exchanger that may exchange heat to a customer plant water system or a water-to-air exchanger. The next element in the loop is a resin bed demineralizer tank. This item is available with a mixed resin bed that removes both anions and cations and can be recharged with fresh resin beads. It is usually installed with a

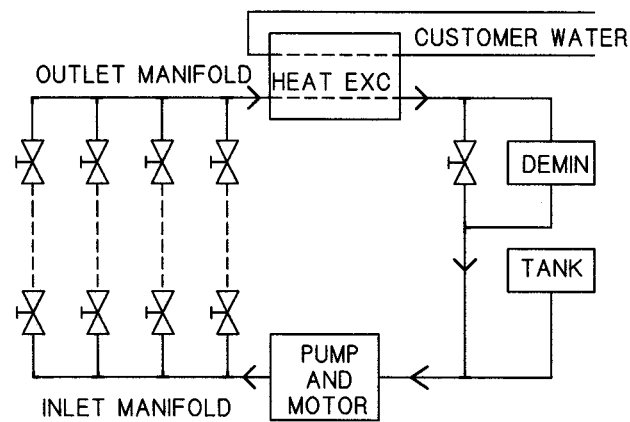

FIGURE 15.2 Basic water cooling system.

bypass valve so that only a portion of the system flow goes through the tank. The tank is required, because the system (even if charged initially with distilled water) will gradually acquire ions from the metal components of the system and will increase in conductivity to unacceptable levels. Finally, the system has a filling tank that allows the system to be recharged and assures a positive head on the pump to prevent cavitation. It is installed at the highest point in the water system. Typically, the water loss is small enough so the makeup can be tap water.

The entire system is stainless steel, plastic, or copper. Hoses are low-conductivity rubber “pot line” hose made for the electrochemical industry. These hoses are rated for a resistance of not less than  $1 \text{ M}\Omega/\text{ft}$  and are pressure tested at 300 psi. Connections are secured with hose clamps over barbed fittings. Typical accessories for a water system would include thermal switches, flow meters and switches, temperature regulators, bypass valves, thermometers, pressure gages, remote metering, level indicators, and vents. Pumps are usually centrifugal types with bronze or stainless steel impellers. Motors may run to several horsepower on larger systems. They are almost always installed as a redundant pair.

Other cooling systems for electrochemical installations have been successfully made using aluminum components and heat sinks with plastic tubing and low-pressure water circulation. As with most designs, there is a comfort factor associated with experience in the various companies building water-cooled equipment.

#### 15.4. Device Cooling

An important area of semiconductor application involves the thermal management of the junction temperature. This is a rather straightforward process for steady-state operation, since the allowable currents are well covered in the data sheet. Thermal characteristics are usually defined by a transient thermal impedance (TTZ) that represents the junction temperature rise above the case temperature for a unit step

input of power dissipation at the junction for a given time. The mounting interface drop and the heat sink characteristics can simply be added to the steady-state junction-to-case thermal impedance of the device to obtain a composite thermal representation. The dissipation can then be multiplied by this impedance to obtain the junction temperature rise above ambient.

Operation of the semiconductor in applications where the current is an odd waveform or a series of unequal current pulses is considerably more difficult. The device TTZ from the data sheet defines the junction rise above the case temperature only for a steady, continued power function of the indicated duration and only when the device is mounted on an infinite heat sink with no interface temperature gradient. There is no simple analytical way to meld the device TTZ with the interface drop and the heat sink TTZ. One way out of this dilemma is to represent the TTZ curve with an electrical network to which other elements in the heat path can be concatenated.

Oliver Heaviside, in the mid-nineteenth century, showed that linear heat flow by conduction can be represented as a distributed R/C network of series R and shunt C. If a constant heat input is applied at one end of an infinitely long network, the temperature at that end will rise in proportion to the square root of time. In sharp contrast to the conventional L/C transmission line, there is no velocity of propagation in an R/C line, nor are there reflections. A current input at one end results in an immediate output at the other end, however greatly attenuated. The late W. E. Newell of the (then) Westinghouse Research Laboratories analyzed the characteristics of various electrical networks in a series of invited papers for the IEEE, wherein he showed that transient heat flow from a semiconductor junction could be represented by a series of asymptotic responses of R/C elements. Then, for any complex input power waveform, the time response could be evaluated by breaking the power waveform into a series of finite impulses, finding the time response for each, and then adding the results. This requires the use of the convolution integral and still begs the question of how to represent additional thermal elements of buses and heat

sinks. The author, faced with the need to evaluate asymmetric cooling of large, “hockey puck” SCRs with complex current waveforms, made the jump to representing the entire cooling path from junction to air by means of a series of concatenated R/C elements. The approach is valid for other semiconductors as well.

The heat transfer from a semiconductor junction to the case is by conduction, although internal material interfaces prevent it from being pure linear diffusion. For most SCRs with brazed interfaces, the TTZ curve rises at a rate somewhat lower than  $t^{1/2}$ . Still, a series of R/C elements can be chosen to represent the curve with minimal error. A minimum number of one element plus one element per decade of time on the TTZ curve is suggested with a capacitor at the junction end and a final resistor. The chosen network should match the TTZ curve down to the shortest time of interest. If the minimum applied pulse is 100 ms long, there is little point in worrying about the junction response at 10  $\mu$ s, although recovery energy may require this consideration as a separate matter. The sum of the resistors must equal the steady-state TTZ, but the capacitors must be selected by trial and error, tapered in increasing capacitance away from the junction. The goodness of fit can be determined by shorting the end away from the junction and applying a step current source of 1 A to the junction end. The voltage at the junction end should then match the TTZ curve.

An additional constraint is that the open-circuit characteristic should depart from the short-circuit characteristic as the slope of the TTZ curve approaches the region of maximum change of curvature. The network that satisfies these two conditions should be a reasonable approximation to the TTZ characteristic under both open- and short-circuit conditions. The interface drop can be added as a resistor to the network output resistor. A heat sink TTZ characteristic can be treated in similar fashion, although a single R/C section may suffice with an input capacitor and a shunt resistor equal to the steady-state TTZ. These several networks can then simply be concatenated for an overall TTZ network. Then, any arbitrary power dissipation function can be input as a current at the junction end to develop a transient junction



temperature response. The circuit can be solved by numerical integration of the network parameters.

If the SCR has asymmetric cooling on the two sides of a hockey puck construction, the double-side-cooled thermal network can be split in two to represent the two directions of heat flow from the junction. The single-side-cooled curve should not be used, because it already accounts for bidirectional heat flow at short times. The two input capacitors can be paralleled into a single capacitor. The incremental input current into this capacitor at each time step in the integration will be the current representing junction dissipation less the prior step currents in each direction, and the incremental voltage is equal to  $i\Delta t/C$ ,  $C$  being the parallel capacitor value. Again, simple Euler integration is usually satisfactory.

The procedures described are demonstrated in the example that follows. It describes the thermal behavior of a 125-mm SCR used in a converter for repetitive pulsed currents.

Figure 15.3 shows the TTZ curve of the SCR and the response of the network representation of Fig. 15.4. The vendor's TTZ curve for double-sided cooling is shown in dots, whereas the short-circuit and open-circuit network responses are in curves. The response is plotted

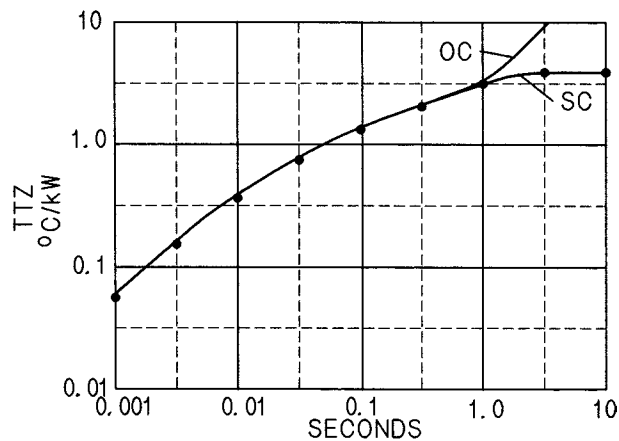

FIGURE 15.3 Transient thermal impedance curves.

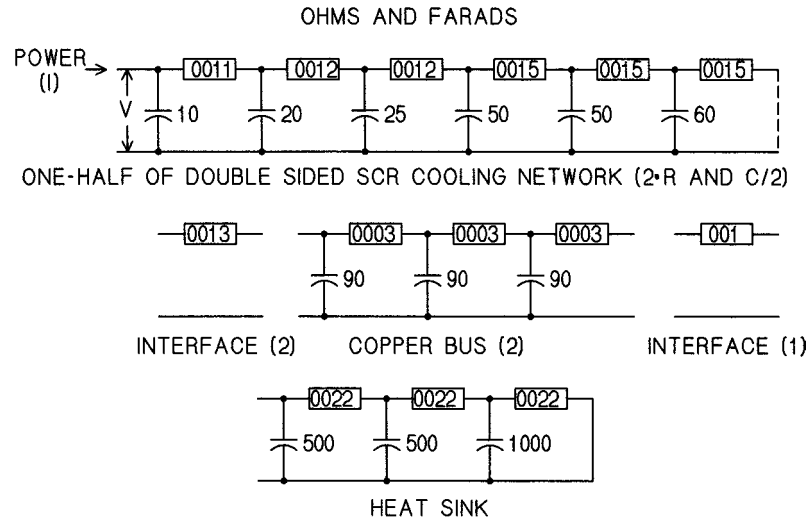

FIGURE 15.4 Thermal network elements.

for resistor values one-half of those in Fig. 15.4 with the capacitor values doubled, because the network of Fig. 15.4 proceeds in both directions from the SCR junction. For the SCR alone with double-sided cooling, the resistors and capacitors in Fig. 15.4 are effectively paralleled. The split in the representation was made because the heat sinking is asymmetric.

The SCR in pulsed service conducts a linear current that rises to 5000 A in 1 sec and then drops immediately to zero in a repeating pattern at 10-sec intervals. Dissipation was developed from the data sheet curve of voltage drop with current. The SCR was mounted between two copper buses, one of which interfaced to a heat sink. The various elements of this representation are concatenated as shown in Fig. 15.4. The power dissipation at the junction was input as a current source to the composite thermal network shown in Fig. 15.5.

Figure 15.6 shows the transient junction temperature rises for a single pulse and for the series of ten. Although the examples show only the junction temperature rise, the network can yield temperatures rises at the SCR surfaces and at the heat sink surface as well. At all points in the network external to the SCR, the voltage represents the temperature rise.

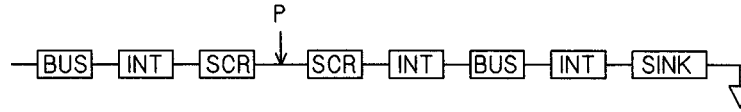

FIGURE 15.5 Composite thermal network

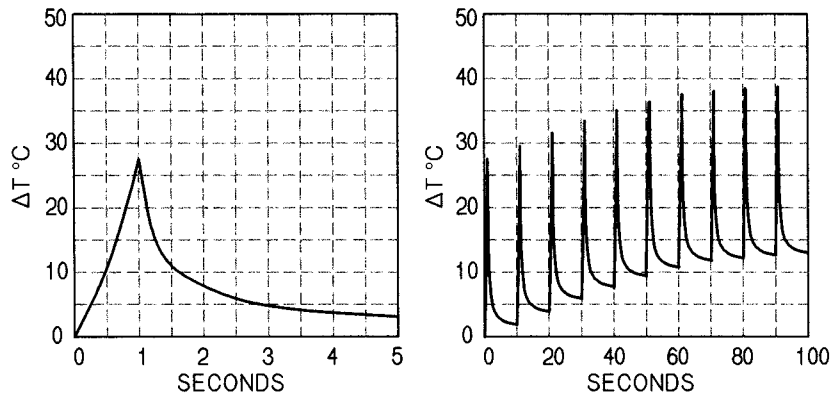

FIGURE 15.6 SCR transient junction temperature rise.

## 15.5. Semiconductor Mounting

All power semiconductors require a flat surface for mounting. A general standard is that the surface should be flat to 0.0005 in/in with a surface finish of 32  $\mu\text{in}$  or less. The surface must be cleaned of all grease and oxides by using fine steel wool. The mounting surface should be lightly covered with a joint compound as recommended by the semiconductor manufacturer. This should be applied and then smoothed off with a stiff card. Only a very fine layer is required, and production workers should be cautioned against using too much compound. A little is good, more is not better.

Puck-type diodes and SCRs are mounted with clamps that provide the required force. Some clamps use gages to indicate the proper pressure, whereas others use inversely loaded Belleville washers. Care should be taken to ensure that the clamps are evenly tightened and that they provide a uniform pressure across the semiconductor surface.

One technique is to tighten the nuts on the two sides finger tight, check for even lengths of free bolt threads, and then alternately tighten the nuts one-half turn at a time until the correct pressure is indicated.

Power IGBTs are housed in epoxy or other molded plastic packages with an integral mounting plate. Again, joint compound should be used sparingly, but the mounting bolts can be driven tight.

## Chapter 16

---

---

# Power Electronics Applications

Power electronics has penetrated nearly every field of human endeavor. Fuel cells and inverters provide ultra-reliable power for critical industries. Electric utility systems employ HVDC converters and var compensators to control voltage and power levels. Lamp dimmers allow control of residential lighting levels. Motor drives, the largest user of power electronics, are at home in pipeline pumping, power station draft fans, and air conditioning systems. They propel luxury cruise ships and grimy freight locomotives and serve a host of other applications. They bring precise speed and torque control with lower energy use. IGBT choppers in DC arc furnaces have tamed the power factor and flicker problems of AC furnaces and reduced electrode consumption. Power electronics is here to stay! Some of the many uses of power electronics are described in this chapter.

### 16.1. Motor Drives and SCR Starters

AC and DC motor drives and SCR starters have been touched on in previous chapters. Here, some of the applications will be discussed, and variable-speed pumps are a good place to start. Prior to inexpensive variable-speed drives, fluid flow in the chemical process industries and municipal water works was controlled by throttling valves on

constant-speed pumps. At low flow rates, the pumps were very inefficient, and the lost energy went into heating the fluid. With a variable-speed drive, the pumps can be speed controlled to meet the fluid flow demand with no loss of efficiency. The same is true for pipeline pumping of liquid fuels where the same advantages accrue in drives to 10,000 hp.

Centrifuges are used for separating liquefied material mixtures. They must be accelerated as quickly as possible and then decelerated quickly when the process step is over. Torque controlled, regenerative variable-speed drives and motors make quick work of the job. Hoists and elevators can be hoisted smoothly and then regeneratively braked with variable-speed drives to save on energy. Dynamometers have the same requirements. Multiple motors in steel and paper lines can be precisely controlled with constant, synchronized speeds, and they can maintain synchronism when accelerating or decelerating.

In the latest diesel electric locomotives, AC inverters power induction motors on the axles. They provide dynamic braking to minimize brake shoe wear and can immediately reduce torque on a slipping wheel to maintain optimum traction. Induction motors stand up to the rigors of railroad service much better than DC motors.

Ventilation systems operating from variable-speed drives do not have the annoying off-on characteristic of constant-speed fans, since they can be continuously speed controlled to maintain the required air flow. Furthermore, they reduce wear and tear on the ventilation system by eliminating transient starting torques.

Coal-fired electric utility generating stations use variable-speed drives on forced and induced draft fans for boilers, thereby saving the cost of using throttling methods to control air flow. These units, in the 10,000 hp range, offer important economies in power usage. A kilowatt-hour saved is a kilowatt-hour the utility can sell.

Testing large motor drives is often done with motor generator sets that allow the drive power to be regenerated back to the power line to reduce costs and eliminate the need for a mechanical brake. The arrangement is referred to as a *dynamometer*. When the input and out-

put voltages of a drive are the same, the drive can be tested at full load and line frequency with a “motorless” dynamometer. A three-phase inductor is used to couple the drive output back to the power line, and the drive electronics are phase locked to the line. By displacing the relative phases of the drive and line through the control electronics, a full range of load currents can be obtained. The drive, in effect, becomes a synchronous generator tied to the power line through its internal reactance. The cost and losses of a reactor are far less than those of a motor generator set, and the only power required is to support the losses of the drive and reactor. An auxiliary transformer can be used to match voltages when required. This arrangement has enabled testing of 20,000-hp drives at full load with a 2500-kVA supply rating.

SCR motor starters can often replace variable-speed drives as a lower-cost method of controlling starting currents in large AC motors. In fans and pumps, the torque requirements at low speeds are modest, and starting current may be as little as half of the across-the-line starting current. Furthermore, the starting current may be ramped up so as to permit coordination with capacitors switched in and out to control the voltage.

Another interesting use of AC motor starters is an SCR gating technique that allows the starter to operate induction or synchronous motors for a short time at very low speeds with high torque. This has proven useful in rotary kilns and mixers in the cement industry.

## **16.2. Glass Industry**

For over 40 years, the glass industry has used SCR-controlled melters for flat glass, container glass, and fiberglass operations. Electric melting reduces dust from gas firing and offers better temperature control. The power controllers must be designed to eliminate any residual DC component in the AC power, because a DC component will cause the electrodes to plate out into the glass and also produce bubbles, the

bane of glass companies. In fact, some companies are using high-frequency IGBT supplies for elimination of bubbles in special glasses. In the fiberglass industry, SCR controls not only melt and control the temperature of the glass supply but also control temperatures of the nozzles that spray the fine filaments of glass. These systems utilize power controllers to 600 V with currents as high as 10 kA.

### 16.3. Foundry Operations

Furnaces for continuous casting lines, such as those for engine blocks, have a graphite rod above a refractory cupola that is charged with molten metal. The electrically heated rod maintains the melt by radiant heat. Power controllers adjust the rod current to maintain an optimum melt temperature for casting. Since the rod gradually ages to a higher resistance, the supply must operate at constant power over a wide range of load resistances, and the autotapchanger circuit has been popular in these applications. The environment is not friendly to electrical equipment because of conductive dust that collects on everything. For this reason, these supplies are totally enclosed, sealed, and water cooled. Figure 16.1 shows a schematic of a typical installation.

Related uses are in annealing wire and strip. Electric heaters anneal the strip by radiant heat, or a current is passed through the material as it travels between roller electrodes and is resistance heated. Both systems have used SCR controllers.

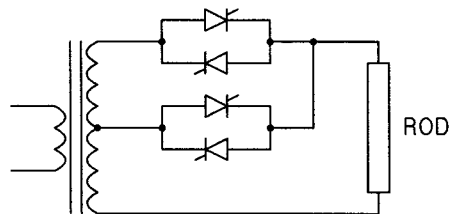

FIGURE 16.1 Rod furnace autotapchanger supply.



## 16.4. Plasma Arcs and Arc Furnaces

In these special heaters, a feed gas is blown through a high-power electric arc to form a superheated plasma. Such systems have been used to reclaim material from dust formed by blast furnaces and collected in precipitators or bag houses. The plasma arc melts the material before serious oxidation takes place. Power electronics plasma arc supplies have also been built in power ratings to 25 MW for experimental use, one for simulation of reentry heating in space vehicles.

IGBT choppers for DC arc furnaces are being used at 100-MW power levels. They are able to control the arc current in a millisecond or so and allow the melt to proceed at essentially constant current with improved throughput. AC arc furnaces must control the arc current by electrode positioning controls, a slow operation at best. DC furnaces with chopper control are free from the annoying flicker that AC furnaces produce, and they also reduce electrode consumption. The higher cost of choppers is offset by the fact that DC furnaces do not require a var compensator for flicker control, and they operate at a better power factor. They also can utilize less-expensive power transformers, since there is no need for bracing to support short-circuit forces.

## 16.5. Electrochemical Supplies

The very high-current DC supplies for electrochemical (pot line) use in metals reduction and chlorine production have traditionally used silicon rectifiers with saturable reactors and tap-changing transformers for continuous current control over a wide range. IGBT choppers are penetrating this field, because they can immediately interrupt short circuits and inherently operate at a good power factor. Furthermore, they can be easily modularized for maintenance and reliability. The chopper supplies are similar to the DC arc furnace choppers. The systems generally use an oil-filled power transformer from the incoming utility supply and a series of phase shifted, water-cooled

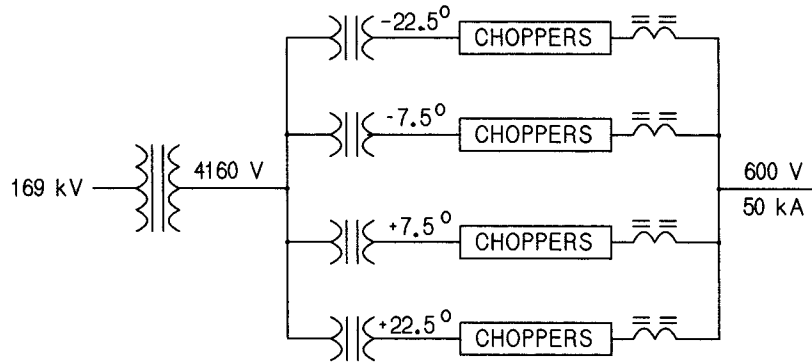

FIGURE 16.2 Typical electrochemical supply.

transformers to power the choppers. Power levels are unlimited. Figure 16.2 shows a typical system with a 24-pulse transformer rectifier and chopper system.

### 16.6. Cycloconverters

These units are a special case of motor drives, since they can also be used in fixed-frequency applications and can supply high overload currents for protective relay coordination in large installations. They are currently used to convert 60 to 25 Hz for the catenary system of Amtrak in the New York to Boston corridor. Another use is for ship propulsion, where they provide excellent maneuverability. They convert a fixed generator frequency to a variable frequency for the propeller synchronous motors. As described earlier, they have acted as frequency changers for 25-Hz plant supplies from the 60-Hz utilities. The only serious barrier to the application of cycloconverters is that the output frequency must be less than half of the input frequency to avoid asymmetry of output voltage waveforms. However, they also operate at a poor power factor and have an unpleasant series of harmonics and intermodulation products on the incoming power line current. Figure 16.3 shows the basic schematic of a three-phase cycloconverter. Note that the three dual converters are supplied from a

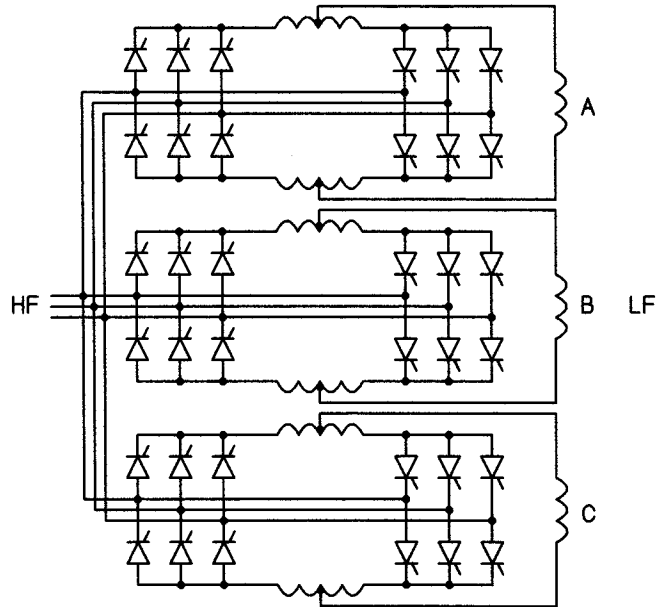

FIGURE 16.3 Three-phase cycloconverter.

common source and require isolated outputs. They could also be operated with three isolated input windings from a transformer to supply a three-phase, nonisolated output, as was done on a shop supply.

### 16.7. Extremely Low-Frequency Communications

An interesting application of current source SCR inverters was the U.S. Coast Guard's extremely low frequency (ELF) communications system for submarines (Fig. 16.4). Operating with frequency shift keying, typically 72 to 80 Hz at 600 kW, they drove long dipole antennas that were grounded at the far ends, 6 to 12 mi from the station. The current was driven far into the ground in the poorly conducting rocks of the Canadian Shield at the station locations in northern Wisconsin and Michigan. The antennas acted as lossy loops, and right-angle pairs allowed some directivity. Messages could be received by

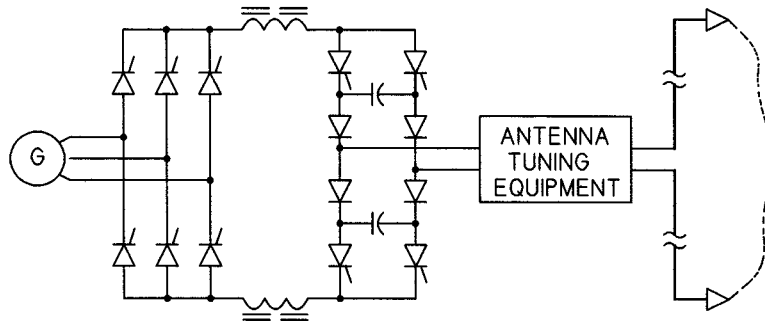

FIGURE 16.4 ELF transmitter.

submarines at operational depths in the Mediterranean, but they required as long as 15 min to decode a three-letter code group. Transmitters and receivers were phase locked by satellites and atomic clocks on the submarines. The recoverable signal was as much as 40 dB below the noise level. Regrettably, this fascinating system is now of historical interest only, since it was decommissioned in the spring of 2004.

### 16.8. Superconducting Magnet Energy Storage

Superconducting magnet energy storage (SMES) describes a system of storing energy in a magnetic field for use in utility peaking service in much the same fashion as hydro storage systems. SMES requires the use of superconducting magnets to get low enough losses to be practical, but the cryogenic systems appear to lack the robust features necessary for utility operations. Higher-temperature superconductors may make the system practical for general use. An experimental SMES system operated on the Pacific Intertie to inject an AC current to offset an inherent stability limit in the hydro generation of the Bonneville Power Administration. This injection raised the stability limit of the AC transmission system by several hundred megawatts for an input of 12 MW at 0.3 Hz.

## 16.9. 600-kW Opamp

Oak Ridge National Laboratories required a very low-ripple, four-quadrant, 300-V, 2000-A DC power supply for superconducting magnet research. The unit was built as a single-phase dual converter with circulating current reactors so it could maintain a smooth current control through zero. It was followed by a four-pole Tchebycheff filter with 3 dB ripple in the passband and one farad of filter capacitance. The particular filter was chosen to provide a steep descent into the stop band with a minimum overshoot on excitation. The unit produced an output with less than 0.1% ripple and a slew rate from full positive to full negative voltage in 40 ms. Charging current into the filter on a step change of command was 4000 A. (See Fig. 16.5. Note the use of diodes to protect the electrolytic capacitors from reverse voltage.)

## 16.10. Ozone Generators

Commercial production of ozone for the process industries and water purification is done with a high-voltage glow discharge that ionizes  $O_2$  to  $O_3$ . The process is enhanced by the use of a high-frequency source. Supplies have been built with IGBTs operating at 30 kHz and 150 kW. Zero current switching is used to minimize IGBT dissipation.

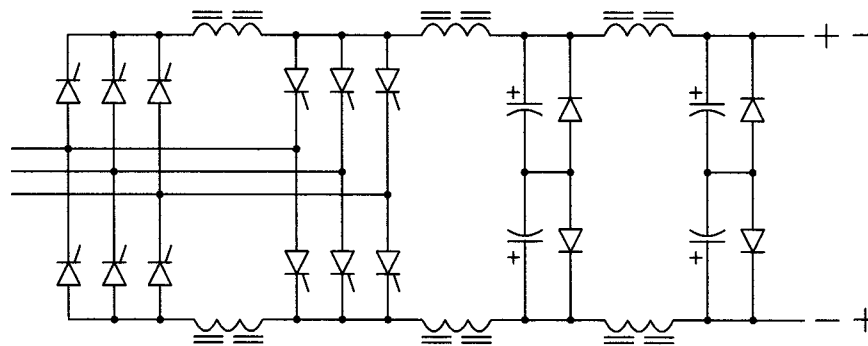

FIGURE 16.5 600-kW Opamp.

Fast SCR crowbars are used to short the source in the event of an arc and to recover quickly to resume production.

### 16.11. Semiconductor Silicon

Silicon for the semiconductor industry is made by melting sand with an SCR-controlled plasma arc in a reducing atmosphere. Chemical processing then converts the silicon to trichlorosilane with reactants including silicon tetrachloride, hydrogen, dichlorosilane, and monochlorosilane to produce a high-purity silane,  $\text{SiH}_4$ . The silane gas is allowed to deposit on the surface of a thin, high-purity silicon rod that is electrically heated to near-incandescence by an SCR supply. As the rod diameter builds up with the deposited material, the supply must operate at progressively higher currents and lower voltages to maintain the required heat with losses from radiation and process gas cooling.

The resultant polycrystal silicon rods are crushed and melted in graphite crucibles heated by SCR supplies. Single-crystal rods are then slowly pulled from the melt following insertion of a seed crystal. Final impurities are removed by an induction coil that produces a melt zone, which slowly travels the length of the rod. Impurities are swept along with the melt zone. The final single-crystal rods are sliced for use in semiconductor devices.

### 16.12. VAR Compensators

These systems consist of a capacitor bank and an SCR-controlled inductor (Fig. 16.6). If the inductor current is zero, the capacitors act as power factor correction and will boost the voltage of the feeder to which they are connected. As the inductor is phased on by the SCRs, the effect of the capacitors is reduced by the inductive current, and the feeder voltage will drop. The var compensator can maintain a constant feeder voltage in spite of wide load variations, such as will result from

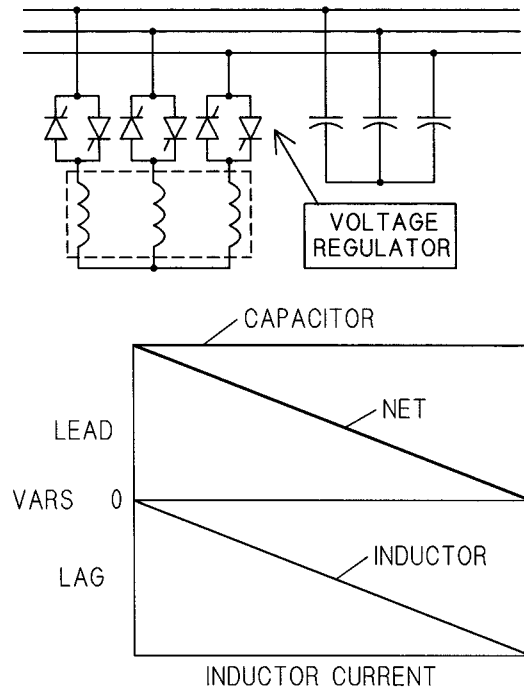

FIGURE 16.6 VAR compensator and control range.

an AC arc furnace. The operation is fast enough to substantially reduce the flicker effect on the feeder. VAR compensators are also used to control voltage swings from load changes on long transmission lines where capacitive effects produce a high source impedance.

### 16.13. Induction Furnace Switch

Figure 16.7 shows an unusual application of SCR control to induction furnaces in the automotive industry. Induction furnaces operate by inducing eddy currents in a work piece for surface hardening, melting, annealing, and a number of other applications in industry. Capacitors are used to tune the load for improved power factor. Because they operate in production processes, the controls must cycle off and on many times per hour.

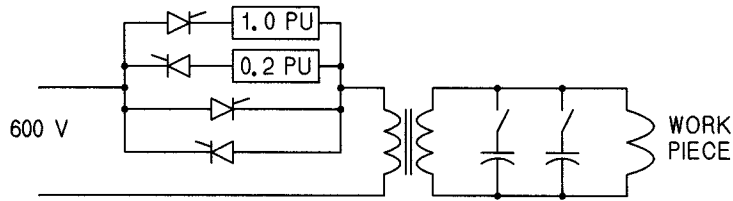

FIGURE 16.7 Solid-state contactor.

Contactor control is rough duty on the contactor and transformer because inrush currents take their toll on both—in the form of contact erosion on the contactor and damage to the transformer from the mechanical forces of the inrush current.

The SCR contactor was developed to deal with this problem. Rated 600 V at 3000 A, the first SCR turns the transformer and load on through a 1.0 per unit resistor for one-half cycle. The second SCR connects through a 0.2 per unit resistor for another half-cycle and then the main two SCRs are enabled and the AC switch handles the current for the duration of the process cycle. The two resistors enable the transformer flux to be established with the current held to a maximum of 2.0 per unit, an acceptable limit.

The limited duty on the two SCRs with resistors allowed them to be relatively small types. The solid-state contactor solved the problem.

### 16.14. Tokamaks

This Russian acronym is derived from the Russian words for toroidal chamber machine, a configuration devised by the Russians for research into magnetic plasma fusion energy. The tokamak consists of a large donut-shaped device that confines a high-energy plasma by magnetic fields. The primary plasma confinement is by means of a toroidal winding. The winding is excited by several hundred kiloampere pulses of a second or so duration that develop an intense circular magnetic field. The coils are cooled by water or, in some cases, liquid nitrogen. Auxiliary coils ignite, position, and control the plasma.



The author had the privilege of designing a number of tokamak supplies for magnetic plasma fusion research facilities. The last and largest of these was for the Alcator C-MOD tokamak at MIT, an installation mentioned previously. The required field current was 265 kA with a steady-state voltage requirement of nearly 900 Vdc. Operation at 900 V output from the converters resulted in an unacceptably long rise and fall time of current, yet the 225-MVA stored energy supply generator was not able to supply 265 kA dc at a higher voltage. The solution was to use the autotapchanger circuit shown earlier. The process could be started at a high voltage, and the 1500-V converter gradually phased back to the 900-V converter at full current. The performances of 900-V and 1500-V systems, as well as the ATC, are shown in Fig. 16.8. Note that the ATC does nearly as well as a 1500-V system as regards rise and fall times but has the generator current of a 900-V system. It met the objectives of minimum rise and fall times without overloading the generator.

### 16.15. Multi-tap Switching

One of the national laboratories required a widely variable source of AC power for some resistance heaters, but the staff was concerned about using phase-controlled SCRs because of switching transients.

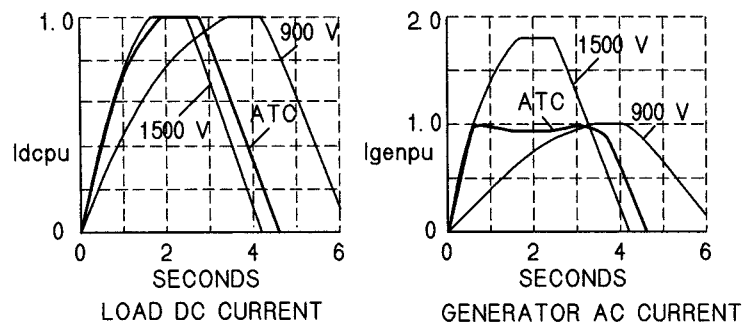

FIGURE 16.8 Autotapchanger performance.

The laboratory had sensitive thermocouple amplifiers that had to be protected. The solution to the problem is shown in Fig. 16.9. A water-cooled transformer was made with every secondary turn over the required range tapped and connected to a pair of SCRs. The controls fired the SCRs at voltage zero crossings with almost no transient disturbances. More taps were used than are shown in the figure, and the design met the objectives.

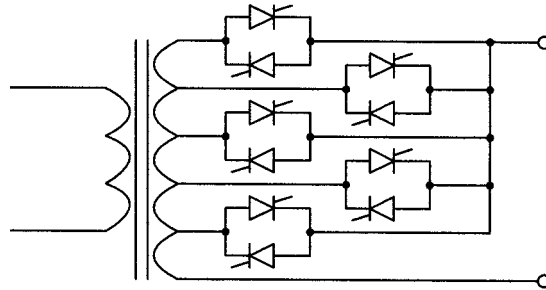

FIGURE 16.9 Wide-range, zero-switched tap changer.

## Appendix A

---

---

# Converter Equations

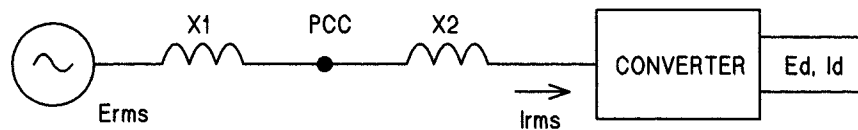

FIGURE A.1 Single line diagram.

### A.1. Definitions

$\alpha$	Phaseback angle—delay of conduction angle from earliest possible point
$u$	Commutation or overlap angle—duration of current transfer between phases and width of commutation notch in voltage
$X_{pu}$	Source reactance—per unit short circuit reactance on converter rating base
$k$	Ratio of reactance on line side of PCC to total reactance; $k = X_1/(X_1 + X_2)$
$E_{rms}$	RMS AC line-to-line voltage
$E_{do}$	Open-circuit DC output voltage of converter with no phase-back ( $\alpha = 0$ )

$E_d$	DC output voltage under rated load
$\cos(\varphi)$	Displacement power factor—cosine of angle between fundamental line-to-neutral voltage and fundamental current
$I_{rms}$	RMS AC line current
$I_d$	DC load current
$I_{pu}$	Per unit AC or DC load current
$I_{hpu}$	Per unit harmonic line current at harmonic, $h$
$THD_v$	Voltage total harmonic distortion at PCC
$I_{fpu}$	Per unit peak asymmetric fault current
$PCC$	Point of common coupling between utility and customer—usually the metering point

## A.2. Equations at Full Load<sup>1</sup>

1.  $E_d = 1.35 E_{rms}$
2.  $E_d = E_d[\cos(\alpha) - X_{pu}/2]$
3.  $E_d = E_d(1 - X_{pu}/2) \quad (\alpha = 0)$
4.  $E_{dpu} = \cos(\alpha) - X_{pu}/2$
5.  $E_{dpu} = 1 - X_{pu}/2 \quad (\alpha = 0)$
6.  $\cos(\alpha + u) = \cos(\alpha) - X_{pu}$
7.  $\cos(u) = 1 - X_{pu} \quad (\alpha = 0)$
8.  $\cos(\alpha) \approx \cos(\alpha + u/2) \quad (\alpha \neq 0)$
9.  $I_{rms} \approx 0.816 I_d$
10.  $I_{hpu} = 1/h \quad (h = 6n \pm 1)$
11.  $TDD_v \approx k\sqrt{u} \sin(\alpha + u/2)$
12.  $I_{fpu} \approx 2/X_{pu}$

---

<sup>1</sup>Note: For operation at less than full load, replace  $X_{pu}$  in Eqs. 2 through 7 with  $X_{pu} I_{pu}$ .

## Appendix B

---

---

# Lifting Forces

Lifting forces on cabinets for handling by a crane can be determined from measurements or calculation of the center of gravity and location of lifts. The basic consideration is that the moments about the pivot point must always balance. The pivot point is the cabinet end that remains on the floor with a single lift. One moment is the total weight, acting at the center of gravity, multiplied by the distance from the center of gravity to the pivot point. The other moment is the lifting force multiplied by the distance from the lift point to the pivot point. These two moments must always be equal. If the total weight and the center of gravity are known, the lifting forces can be calculated. If the two lifting moments are determined experimentally, the center of gravity and total weight can be calculated. The following example of a double lift may help. The lift forces  $F_1$  and  $F_2$  and their locations are presumed known, and the weight,  $W$ , and center of gravity,  $X$ , are to be found (Fig. B.1).

### B.1. Calculations

$$M_1 = W(C - X)$$

$$M_2 = F_1 C \text{ at } L_1$$

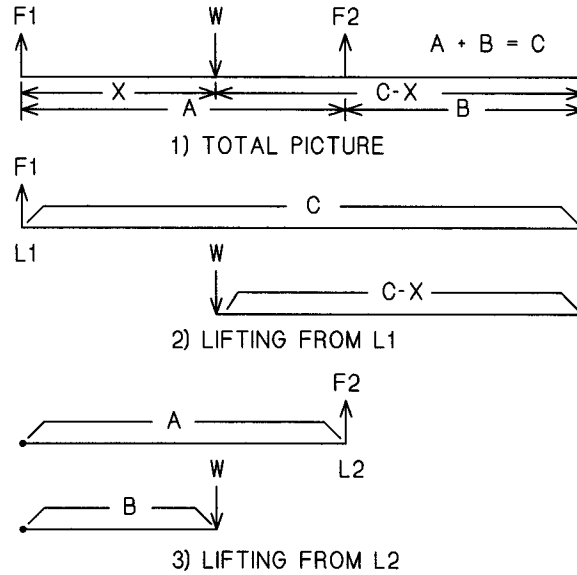

FIGURE B.1 Lifting forces and moments.

Equating  $W C - W X = F1 C$

$$M3 = W X$$

$$M4 = F2 A \text{ at } L2$$

Equating  $W X = F2 A$

Substituting  $W C = F1 C + F2 A$

Then  $W = F1 + F2 A/C$

And  $X = (F2 A)/W$

## Appendix C

---

---

# Commutation Notches and THD<sub>v</sub>

A simple formula can be developed to calculate the per unit voltage distortion on a bus when feeding a six-pulse thyristor converter. The derivation follows with  $X1$  and  $X2$ , the per unit reactances as described below;  $\alpha$ , the phaseback angle;  $u$ , the commutating angle; and a peak line voltage of 1.00 pu. Full load is assumed. Calculate the  $THD_v$  at the PCC.

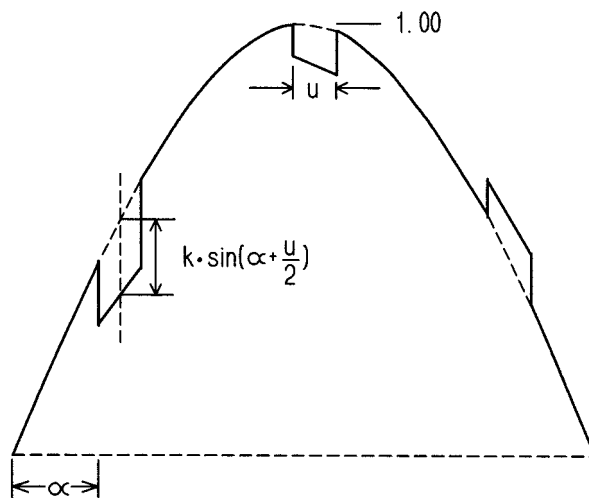

FIGURE C.1 Voltage distortion waveform.

1.  $k = X1/(X1 + X2)$  ( $X1$  is the per unit reactance on the line side of the PCC and  $X2$  is on the load side).
2.  $X_c = X1 + X2$  (commutating reactance)
3.  $\cos(\alpha + u) = \cos(\alpha) - X_c$ .
4. There is one commutation notch determined by  $k$  and two at half-value as shown in Fig. C.1 in the line-to-line waveform with  $k = 0.33$ .
5. The main notch has an average depth of  $k \sin(\alpha + u/2)$  and a width of  $u$ .
6. The RMS value of the notches is  $k \sin(\alpha + u/2) [3 u/(2 \pi)]^{1/2}$ .
7. By approximating  $(3/\pi)^{1/2}$  as 1.0, and dividing by the approximate RMS value of per unit line-to-line voltage as  $(1/2)^{1/2}$ , the  $THD_v$  becomes

$$THD_v = k \sin(\alpha + u/2) (u)^{1/2}$$

with  $\alpha$  and  $u$  in radians



## Appendix D

---

---

# Capacitor Ratings

ANSI/IEEE Std. 18-1980 specifies that power factor correction capacitors must be applied within the following guidelines, no one of which may be exceeded:

1. RMS voltage not to exceed 110% of rated
2. Peak voltage not to exceed 120% of rated
3. RMS current not to exceed 180% of rated<sup>1</sup>
4. kVA not to exceed 135% of rated

The calculations are to be made as follows:

1. RMS voltage—The RMS applied voltage is the square root sum of squares of all fundamental and harmonic voltages across the capacitor. The fundamental voltage should be taken as the maximum sustained line voltage and must include any voltage rise due to a tuning reactor. Harmonic voltages are calculated from the harmonic currents and the capacitor reactances at harmonic frequencies. The RMS voltage limit is associated with dielectric heating effects.

---

<sup>1</sup>Note that some 480-V and 600-V power factor correction capacitors may be limited to 135% rated current.

2. Peak voltage—The peak voltage is calculated as the peak fundamental voltage plus the peak effect of all harmonic voltages. In principle, this requires an arithmetic addition of all harmonic voltages since they could, admittedly with a small probability, combine as an additive peak. Common sense, however, would suggest the arithmetic addition of the major harmonic voltages and an RMS combination of the remaining peak harmonic voltages. The peak voltage limit is associated primarily with the dielectric and corona stresses.
3. RMS current—The RMS current is the result of fundamental current and all harmonic currents. The fundamental current must be adjusted for capacitance tolerance and terminal voltage. The current limit is primarily one associated with foil and terminal heating due to  $I^2R$  losses.
4. kVA—The kVA is calculated as the arithmetic sum of RMS voltage times RMS current for the fundamental and each harmonic. Capacitive reactances at harmonic frequencies can be used to calculate voltages. This limit is sort of a “catch-all” based on experience.

## Appendix E

---

---

# Rogowski Coils

Figure E.1 shows the construction of a Rogowski coil, an air-core current transformer that is especially well suited to measuring ripple currents in the presence of a DC component or measuring pulsed currents. The raw output is proportional to the derivative of the current, and the current can be recovered by an integrator or a low-pass filter. The output voltage is given by

$$e = 4\pi \times 10^{-7} n \times (A/s) di/dt \text{ (MKS units)}$$

$$e = 3.19 \times 10^{-8} n (A/s) di/dt \text{ (inches)}$$

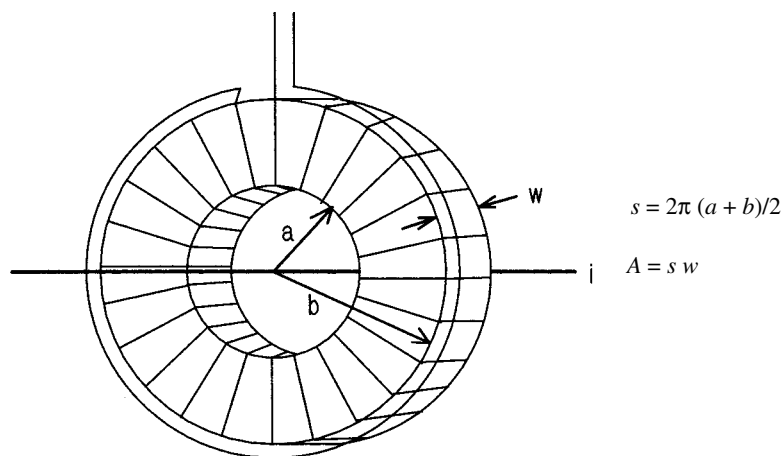

FIGURE E.1 Rogowski coil construction.

where  $n$  is the number of turns,  $A$  is the cross sectional area of the toroid, and  $s$  is the centerline circumference.

The coil is wound on an air-core form of suitable size for the current conductor. The winding should be applied in evenly spaced turns in one direction only—not back and forth—so that capacitive effects are minimized. The far end of the winding should be brought back around the circumference of the coil to eliminate the turn formed by the winding itself. The winding must generally be shielded, since the output voltage is relatively low. The shield should be applied so that it does not form a shorted turn through the opening, and the coil should be equipped with an integral shielded output lead with the ground side connected to the coil shield.

Output from the Rogowski coil can either be integrated with a passive network as an R/C low-pass filter or with an operational amplifier. The advantage of the R/C network is that no power is required for operation. The disadvantages are that it cannot be gated and that the output voltage becomes very low if low-frequency response is required. Although a toroidal form is shown in the sketch, Rogowski coils are commercially available that are wound in the form of a very long, flexible solenoid that can be wrapped around a conductor and then secured mechanically.

Rogowski coils are largely unaffected by stray fields that have a constant amplitude across the coil. A field gradient across the coil, however, will introduce a spurious output if the field is time varying. It is good practice to make the coil as small as possible within the electrical and physical constraints of the equipment. The Rogowski coil can be calibrated from a 50/60-Hz current assuming, of course, that the bandpass of the filter or integrator extends down to those frequencies.

## Appendix F

---

---

# Foreign Technical Words

TABLE F.1 Foreign Technical Words

English	French	German	Spanish
attention	attention	Achtung	atención
capacitor	condensateur	Kondensator	capacitor
circuit	circuit	Strumkreis	circuito
connection	connexion	Verbindung	conexión
current	courant	Strom	corriente
danger	danger	Gefahr	peligro
frequency	fréquence	Frequenz	frecuencia
generator	générateur	Generator	generador
high	haut	hoch	alto(a)
inductor	inducteur	Induktor	inductor
insulation	isolation	Isolierung	aislamiento
insulator	isolateur	Isolator	aislador
motor	moteur	Motor	motor
power	puissance	Macht	potencia
reactor	réacteur	Reaktor	reactor
resistor	résistance	Widerstand	resistencia
temperature	temperature	Temperatur	temperature
torque	couple	Drehmoment	torque
transformer	transformateur	Transformator	transformador
transistor	transistor	Transistor	transistor
voltage	tension	Spannung	voltaje, tensión
wire	fil	Draht	alambre



## Appendix G

---

---

# Aqueous Glycol Solutions

Most liquid cooling systems are water based and must be protected from freezing in the northern climates. Ethylene glycol has been the preferred material in solutions up to about 50% by volume for protection to  $-40^{\circ}\text{C}$ . However, more recently, propylene glycol has replaced ethylene glycol in many applications, because it is more friendly to the environment. Slightly more propylene glycol is required for a given temperature protection. It should be noted that the freezing point is the point at which ice crystals first start to form. The solution will slush and circulate at somewhat lower temperatures.

Either glycol must be an industrial grade from a chemical supplier. Proprietary mixtures used for automotive and other cooling applications may contain antioxidants or other additives that will increase the conductivity. Glycol mixtures free of additives are generally compatible with demineralizer resin beds, although the resin bed vendor should be consulted.

The two curves below show the freezing points and thermal conductivity of various mixtures of either glycol. These curves have been derived from published curves based on percent glycol by weight for the two properties. (See Fig. G.1.)

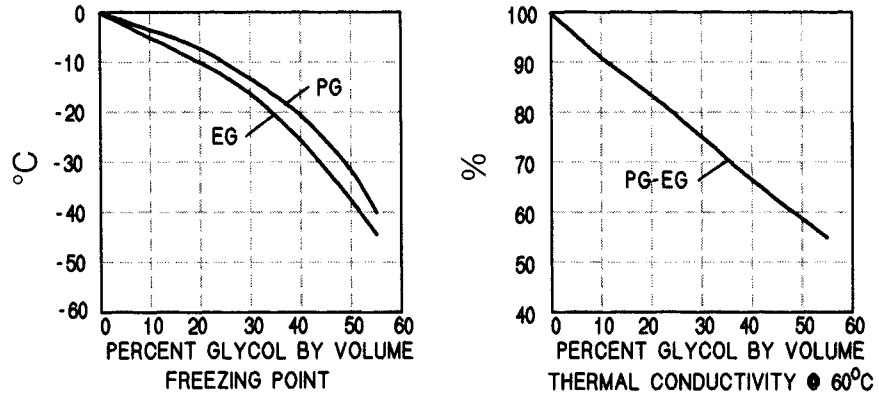

FIGURE G.1 Properties of ethylene and propylene glycol aqueous mixtures.



## Appendix H

---

---

# Harmonic Cancellation with Phase Shifting

### H.1. Expressions

It is well known that a delta to delta-wye three-winding transformer feeding a 12-pulse converter will eliminate harmonics of order  $6n \pm 1$  in the primary current, but just how this is accomplished is not at all obvious, since currents  $30^\circ$  apart certainly do not cancel. If the transformer wye secondary voltage leads the delta secondary voltage by  $30^\circ$ , the following expressions for fundamental currents obtain:

	<b>Phase A</b>	<b>Phase B</b>	<b>Phase C</b>
Delta	$\sin(\theta)$	$\sin(\theta - 120^\circ)$	$\sin(\theta + 120^\circ)$
Wye	$\sin(\theta + 30^\circ)$	$\sin(\theta - 90^\circ)$	$\sin(\theta + 150^\circ)$

If the secondaries carry fifth harmonic currents, these currents will multiply the angles of each fundamental by 5, with the following result:

Delta	$\sin(5\theta)$	$\sin(5\theta - 600^\circ)$	$\sin(5\theta + 600^\circ)$
Wye	$\sin(5\theta + 150^\circ)$	$\sin(5\theta - 450^\circ)$	$\sin(5\theta + 750^\circ)$

These expressions can be rewritten as:

Delta	$\sin(5\theta)$	$\sin(5\theta + 120^\circ)$	$\sin(5\theta - 120^\circ)$
Wye	$\sin(5\theta + 150^\circ)$	$\sin(5\theta - 90^\circ)$	$\sin(5\theta + 30^\circ)$

Harmonic currents in the delta secondary lines will become the same currents in the primary lines. The wye currents, however, will become delta currents in the primary, and the primary line current will be the difference between two wye currents with a ratio of  $1/\sqrt{3}$ . The following equations then apply for primary line currents:

$$\begin{array}{llll} \text{From the delta} & \sin(5\theta) & \sin(5\theta + 120^\circ) & \sin(5\theta - 120^\circ) \\ \text{From the wye} & (I_a - I_c)/\sqrt{3} & (I_b - I_a)/\sqrt{3} & (I_c - I_b)/\sqrt{3} \\ & \text{(Example phase A) } [\sin(5\theta + 150^\circ) - \sin(5\theta + 30^\circ)]/\sqrt{3} & & \end{array}$$

Running out the trigonometric relationships shows the fifth harmonic components of line currents from the wye secondary simply wind up as follows:

$$\text{From the wye} \quad -\sin(5\theta) \quad -\sin(5\theta + 120^\circ) \quad -\sin(5\theta - 120^\circ)$$

When added to the delta line currents, the fifth harmonic components in the line currents vanish identically.

The same kind of analysis will show that the seventh harmonic currents, a positive sequence set, also cancel in the primary, and the same is true for the 17, 19 pair; the 29, 31 pair; and so on. The remaining harmonics are of order  $12n \pm 1$ . A three-winding transformer is not required, nor is the delta-delta-wye configuration. Any winding arrangement that yields a  $30^\circ$  phase shift between load currents will suffice.

Further work in pushing trigonometric relationships around will show that a set of  $0^\circ$ ,  $20^\circ$ , and  $40^\circ$  phase shifts in three windings will eliminate harmonics except for those of order  $18n \pm 1$ , and that a  $0^\circ$ ,  $15^\circ$ ,  $30^\circ$ , and  $45^\circ$  set will leave only harmonics of order  $24n \pm 1$ . Note that a set of  $-22.5^\circ$ ,  $-7.5^\circ$ ,  $+7.5^\circ$ , and  $+22.5^\circ$  will yield identical results. The particular set of phase shifts chosen will typically depend on transformer economics. It is the differences that matter.

In the real world, small asymmetries in lines, loads, and transformers conspire to prevent a total elimination of these harmonics, but the attenuation is generally enough to bring them into compliance with IEEE 519.

## Appendix I

# Neutral Currents with Nonsinusoidal Loads

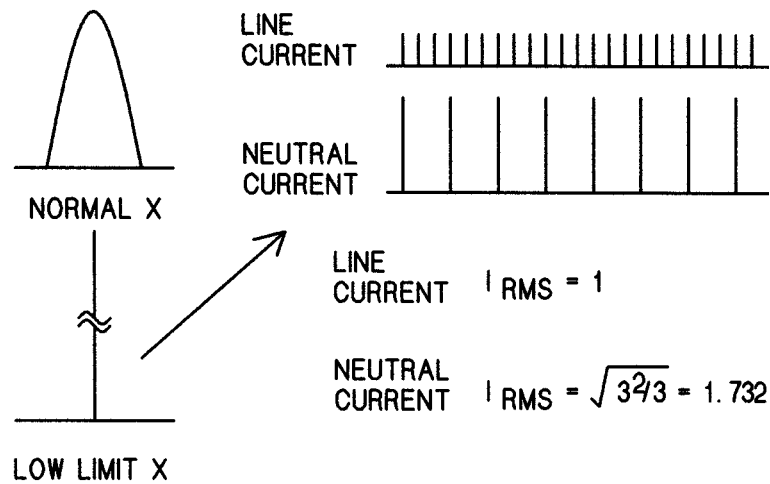

Single-phase, nonsinusoidal loads in commercial buildings such as data processing centers cause large neutral currents. These loads have high levels of zero sequence triplen harmonics, 3, 9, 15, 21..., and these harmonics in the line currents are additive in the neutral conductor. The sketch above shows the normal line current waveform and the waveform as the source inductance approaches zero. In the limit, the current approaches an impulse function with equal current amplitudes

at all harmonic frequencies. In the worst case, 1 A rms current in each line becomes 1.732 rms A of current in the neutral. There are one-third as many harmonics in the neutral as in the line current, but each is three times the amplitude of the line current. Note that the other odd-order harmonics cancel in the neutral with a balanced load.

Older buildings that were wired with reduced capacity neutral conductors in anticipation of reasonably balanced loads with a low harmonic content may face neutral overcurrents when large computer loads are added. The present National Electrical Code recognizes this possibility and now requires uprated neutrals in new commercial construction. These neutral currents will pass through a succession of wye connected transformers with neutrals, so they may be additive at the source. Another potential problem is from DC from half-wave rectifiers. These currents are also additive in the neutrals, but they will not pass beyond the first transformer.

# Index

---

---

## A

Air cooling 205  
American Institute of Electrical  
Engineers 39  
ANSI C34.2 92, 122  
ANSI C57 82  
ANSI/IEEE Std. 18-1980 235  
Arc chutes 17  
Arc heater 43  
Asynchronous inertia 151  
Asymptotic response 50  
Autotap changers 145  
Autotransformer 90

## B

Basic insulation level, see Insulation,  
basic insulation level  
Bode (bodey) plots 50  
Bonneville Power Administration 8  
Boost converter 174  
Bootstrap circuit 175  
Bus inductance 158

## C

C message weighting 199  
Canadian General Electric Company  
159  
Canadian Standards Association 22, 34

## Capacitors

construction 27  
extended foil 27  
ratings 235  
surge 21

Characteristic impedance 66, 67

Choppers 173, 215, 219

Circular mils 21

Coefficient of coupling 74, 75

Common-mode voltage 57, 58

Commutation 123, 124

failure 141  
notches 233  
voltage loss calculation 124

Conductors 12, 21

shielded 23

Contactors 18

Convection 81, 98, 112, 204

Converters 9

boost 174  
dual arrangement 148  
equations 229  
pulsed 163  
SCR 9

Cooling

air 79  
air-cooled heat sink 205  
aqueous glycol solutions 241

- convection 81, 98
  - liquid 25
  - water 206
- Corona 8, 33
- Cosine intercept gate drive 143
- Crosstalk 86
- Current source inverter 149
- Cycloconverters 6, 150, 220
- D**
- Dampers 106
- Demand charges 9
- Demineralizer 207
- di/dt 60
- Differential-mode voltage 57
- Direct axis reactance 104
- Displacement power factor 187
- Distortion
  - current and voltage 199
  - limits 201
- Distortion factor 192
- Dog bones 81
- Dynamometers 216
- E**
- Edison, Thomas 1
- Electric motors 2, 6
- Electric utilities 1, 6
- Electromagnetic interference 61–63, 65, 86, 199–201
- Electrostatic shield 58, 88
- ELF communications 221
- EMALS 112
- Emissivity 204
- Energy and demand 182
- Euler integration 66
- F**
- Faraday screen 58, 88
- Feedback 103
- Filter traps 197
- Flexible AC transmission systems 10, 153
- Flux control 110
- Forward drop 131
- Fourier transforms 190, 191
- Fourier, J. B. J. 189
- Fringing 96
- Furnaces 219
- Fuses 24, 31
  - slo-blo 31
- G**
- Gate drive 127
  - cosine intercept 143
- Gate drives 58
- Gate turnoff thyristor 170
- Generators 2
  - turbine 5
- Glycol 80
- Grounding 11, 19, 61
  - straps 33
- H**
- Hall effect 100
- Harmonic interference 199
- Harmonic resonance 26
- Harmonics 26
  - compensation 196
  - mitigation 193
  - traps 197
- Heaviside, Oliver 209
- Highpass filters 198
- High-voltage DC 8, 9, 153, 215
- Hydro-Québec 8
- I**
- IEEE 18-2002 26
- IEEE 519 119, 186, 200, 244
- IEEE C57 73
- Impedance 38
- Inductance 94
  - bus 158
  - stray 172
- Institute of Electrical and Electronics Engineers 34

- Insulation 8, 22, 23, 33, 82, 145
  - basic insulation level (BIL) 8, 19, 84, 85
  - classes 82
  - failure 177
  - integrity 88
  - materials 82, 83
  - mineral oil 80
  - temperature considerations 82
  - transformer 84
- Integrated gate bipolar transistor 60, 171
- Integrated gate controlled thyristor 170
- Intermodulation 151
- Isolation transformers 194
- L**
- Laser 145
- Lightning arresters 8, 19, 20
- Load-commutated inverter 149
- Low-pass filters 198
- M**
- Margin angle 141
- Metal oxide varistors 17, 35
- Motor
  - induction 3
  - synchronous 103, 149
- N**
- National Electric Code 22
- National Electrical Manufacturers Association 34, 110
- Notching 60
- O**
- Oak Ridge National Laboratories 223
- Overload torque 106
- Overshoot 69–71
- Ozone formation 84
- Ozone generation 223
- P**
- Parasitic heating 25
- Peak reverse current 128
- Phase lag 53
- Phasors 40
- Power factor 9, 132, 147
  - correction 19, 25, 183
  - correction capacitors 26
  - definition 181
  - displacement 187
  - true 187
- Power resistors, types 30
- Pulse transformers 154
- Pulsed converters 163
- Q**
- Quadrature axis reactance 104
- R**
- Rail gun 112, 166
- Reactance 38, 42, 60, 75, 76, 78, 124, 165, 193, 217
  - direct axis 104
  - quadrature 104
  - subtransient 105
  - synchronous 105
- Recovered charge 128
- Rectifiers
  - mercury vapor 116
  - multiphase circuits 120
  - single-phase circuits 118
  - vacuum 116
- Reflection coefficient 68
- Regulation 77
- Relays
  - designations 38
  - protective 37
- Resonance
  - harmonic 26
  - parallel 26
- Response
  - asymptotic 50
  - frequency 50

- phase 53
  - time 51
- Reverse current 128
- Ripple 25, 62, 89, 148, 173, 174, 223, 237
- Rogowski coils 100, 237
- S**
- SCR converters 9, 137, 166
- SCR starters 133, 135
- Semiconverter 141
- Shaft encoder 103
- Shielded conductors 23
- Shielding 19, 59, 61, 89
- Simulation software 47
- Skirting 98
- Slip 107
- Slo-blo fuses 31
- Snubber 129
- Spacings, classes 34
- Specific gravity 204
- Specific heat 204
- Stray inductances 172
- Stress cones 23
- Subtransient reactance 105
- Supercaps 171
- Superconducting magnet energy storage 222
- Superconductors 222
- Switchgear
  - circuit breakers 11, 17
  - contactors 18
  - electrical clearance 35
  - isolator switches 16
  - load break 17
  - standards 8
  - transfer switches 13
- Symbols 15
- Symmetrical components 39, 41
- Synchronous motor 103
- Synchronous reactance 105
- T**
- Tchebycheff filter 223
- Telephone influence factor 199
- Tesla, Nikola 3
- Thermal conductivity 204
- Tick-tock regulator 169
- TIF weighting function 199
- Tokamaks 226
- Torque 106, 108
- Total demand distortion 201
- Total harmonic distortion 192
- Transformers 3, 164
  - autotapchanger 147
  - basic arrangements 78
  - connections 90
  - interphase 89
  - isolation 194
  - phase shifting 92
  - pulse 154
  - types and characteristics 81
- Transient thermal impedance 208
- Transients 19
- Transmission 3, 8
- Transport lag 43, 54
- Transposition 86
- Turbines 5, 7, 101
  - generator 5
  - wind 110
- U**
- Underwriter's Laboratories 22, 23, 34, 83
- Uninterrupted power 13
- V**
- Vacuum tube rectifiers 116
- Vector torque control 110
- Velocity of propagation 67
- W**
- Water cooling 80, 206
- Westinghouse, George 3