

# SWITCHMODE™ Power Supply Reference Manual



ON Semiconductor®



# SWITCHMODE™ Power Supplies

---


## Reference Manual and Design Guide

SMPSRM/D  
Rev. 3, July–2002

© SCILLC, 2002  
Previous Edition © 2000  
“All Rights Reserved”



## SMPSRM

**ON Semiconductor** and  are registered trademarks of Semiconductor Components Industries, LLC (SCILLC). SCILLC reserves the right to make changes without further notice to any products herein. SCILLC makes no warranty, representation or guarantee regarding the suitability of its products for any particular purpose, nor does SCILLC assume any liability arising out of the application or use of any product or circuit, and specifically disclaims any and all liability, including without limitation special, consequential or incidental damages. "Typical" parameters which may be provided in SCILLC data sheets and/or specifications can and do vary in different applications and actual performance may vary over time. All operating parameters, including "Typicals" must be validated for each customer application by customer's technical experts. SCILLC does not convey any license under its patent rights nor the rights of others. SCILLC products are not designed, intended, or authorized for use as components in systems intended for surgical implant into the body, or other applications intended to support or sustain life, or for any other application in which the failure of the SCILLC product could create a situation where personal injury or death may occur. Should Buyer purchase or use SCILLC products for any such unintended or unauthorized application, Buyer shall indemnify and hold SCILLC and its officers, employees, subsidiaries, affiliates, and distributors harmless against all claims, costs, damages, and expenses, and reasonable attorney fees arising out of, directly or indirectly, any claim of personal injury or death associated with such unintended or unauthorized use, even if such claim alleges that SCILLC was negligent regarding the design or manufacture of the part. SCILLC is an Equal Opportunity/Affirmative Action Employer.

### PUBLICATION ORDERING INFORMATION

**Literature Fulfillment:**

Literature Distribution Center for ON Semiconductor  
P.O. Box 5163, Denver, Colorado 80217 USA  
**Phone:** 303-675-2175 or 800-344-3860 Toll Free USA/Canada  
**Fax:** 303-675-2176 or 800-344-3867 Toll Free USA/Canada  
**Email:** ONlit@hibbertco.com

**N. American Technical Support:** 800-282-9855 Toll Free USA/Canada

**JAPAN:** ON Semiconductor, Japan Customer Focus Center  
4-32-1 Nishi-Gotanda, Shinagawa-ku, Tokyo, Japan 141-0031  
**Phone:** 81-3-5740-2700  
**Email:** r14525@onsemi.com

**ON Semiconductor Website:** <http://onsemi.com>

For additional information, please contact your local Sales Representative.

## Forward

Every new electronic product, except those that are battery powered, requires converting off-line 115 Vac or 230 Vac power to some dc voltage for powering the electronics. The availability of design and application information and highly integrated semiconductor control ICs for switching power supplies allows the designer to complete this portion of the system design quickly and easily. Whether you are an experienced power supply designer, designing your first switching power supply or responsible for a make or buy decision for power supplies, the variety of information in the *SWITCHMODE™ Power Supplies Reference Manual and Design Guide* should prove useful.

ON Semiconductor has been a key supplier of semiconductor products for switching power supplies since we introduced bipolar power transistors and rectifiers designed specifically for switching power supplies in the mid-70's. We identified these as SWITCHMODE™ products. A switching power supply designed using ON Semiconductor components can rightfully be called a SWITCHMODE power supply or SMPS.

This brochure contains useful background information on switching power supplies for those who want to have more meaningful discussions and are not necessarily experts on power supplies. It also provides real SMPS examples, and identifies several application notes and additional design resources available from ON Semiconductor, as well as helpful books available from various publishers and useful web sites for those who are experts and want to increase their expertise. An extensive list and brief description of analog ICs, power transistors, rectifiers and other discrete components available from ON Semiconductor for designing a SMPS are also provided. This includes our newest GreenLine™, Easy Switcher and very high voltage ICs (VHVICs), as well as high efficiency HDTMOS® and HVTMOS® power FETs, and a wide choice of discrete products in surface mount packages.

For the latest updates and additional information on analog and discrete products for power supply and power management applications, please visit our website: (<http://onsemi.com>).

# Table of Contents

	Page
Introduction .....	5
Linear versus Switching Power Supplies .....	5
Switching Power Supply Fundamentals .....	5
The Forward–Mode Converter .....	5
The Flyback–Mode Converter .....	7
Common Switching Power Supply Topologies .....	8
Interleaved Multiphase Converters .....	13
Selecting the Method of Control .....	14
The Choice of Semiconductors .....	16
Power Switches .....	16
The Bipolar Power Transistor .....	16
The Power MOSFET .....	17
Driving MOSFETs in Switching Power Supply Applications .....	18
The Insulated Gate Bipolar Transistor (IGBT) .....	19
Rectifiers .....	19
The Magnetic Components .....	21
Laying Out the Printed Circuit Board .....	21
Losses and Stresses in Switching Power Supplies .....	24
Techniques to Improve Efficiency in Switching Power Supplies .....	25
The Synchronous Rectifier .....	25
Snubbers and Clamps .....	27
The Lossless Snubber .....	28
The Active Clamp .....	29
Quasi–Resonant Topologies .....	30
Power Factor Correction .....	32
SMPS Examples .....	35
Integrated Circuits for Switching Power Supplies .....	36
Suggested Components for Specific Applications .....	37
Literature Available from ON Semiconductor .....	56
Application Notes, Brochures, Device Data Books and Device Models .....	56
References for Switching Power Supply Design .....	58
Books .....	58
Websites .....	59
Analog ICs for SWITCHMODE Power Supplies .....	61
ON Semiconductor Worldwide Sales Offices .....	62
ON Semiconductor Standard Document Type Definitions .....	63

## Introduction

The never-ending drive towards smaller and lighter products poses severe challenges for the power supply designer. In particular, disposing of excess heat generated by power semiconductors is becoming more and more difficult. Consequently it is important that the power supply be as small and as efficient as possible, and over the years power supply engineers have responded to these challenges by steadily reducing the size and improving the efficiency of their designs.

Switching power supplies offer not only higher efficiencies but also greater flexibility to the designer. Recent advances in semiconductor, magnetic and passive technologies make the switching power supply an ever more popular choice in the power conversion arena.

This guide is designed to give the prospective designer an overview of the issues involved in designing switchmode power supplies. It describes the basic operation of the more popular topologies of switching power supplies, their relevant parameters, provides circuit design tips, and information on how to select the most appropriate semiconductor and passive components. The guide also lists the ON Semiconductor components expressly built for use in switching power supplies.

## Linear versus Switching Power Supplies

Switching and linear regulators use fundamentally different techniques to produce a regulated output voltage from an unregulated input. Each technique has advantages and disadvantages, so the application will determine the most suitable choice.

Linear power supplies can only step-down an input voltage to produce a lower output voltage. This is done by operating a bipolar transistor or MOSFET pass unit in its *linear* operating mode; that is, the drive to the pass unit is proportionally changed to maintain the required output voltage. Operating in this mode means that there is always a headroom voltage,  $V_{drop}$ , between the input and the output. Consequently the regulator dissipates a considerable amount of power, given by ( $V_{drop} I_{load}$ ).

This *headroom loss* causes the linear regulator to only be 35 to 65 percent efficient. For example, if a 5.0 V regulator has a 12 V input and is supplying 100 mA, it must dissipate 700 mW in the regulator in order to deliver 500 mW to the load, an efficiency of only 42 percent. The cost of the heatsink actually makes the linear regulator uneconomical above 10 watts for small applications. Below that point, however, linear regulators are cost-effective in step-down applications.

A low drop-out (LDO) regulator uses an improved output stage that can reduce  $V_{drop}$  to considerably less than 1.0 V. This increases the efficiency and allows the linear regulator to be used in higher power applications.

Designing with a linear regulator is simple and cheap, requiring few external components. A linear design is considerably quieter than a switcher since there is no high-frequency switching noise.

Switching power supplies operate by rapidly switching the pass units between two efficient operating states: *cutoff*, where there is a high voltage across the pass unit but no current flow; and *saturation*, where there is a high current through the pass unit but at a very small voltage drop. Essentially, the semiconductor power switch creates an AC voltage from the input DC voltage. This AC voltage can then be stepped-up or down by transformers and then finally filtered back to DC at its output. Switching power supplies are much more efficient, ranging from 65 to 95 percent.

The downside of a switching design is that it is considerably more complex. In addition, the output voltage contains switching noise, which must be removed for many applications.

Although there are clear differences between linear and switching regulators, many applications require both types to be used. For example, a switching regulator may provide the initial regulation, then a linear regulator may provide post-regulation for a noise-sensitive part of the design, such as a sensor interface circuit.

## Switching Power Supply Fundamentals

There are two basic types of pulse-width modulated (PWM) switching power supplies, *forward-mode* and *boost-mode*. They differ in the way the magnetic elements are operated. Each basic type has its advantages and disadvantages.

### The Forward-Mode Converter

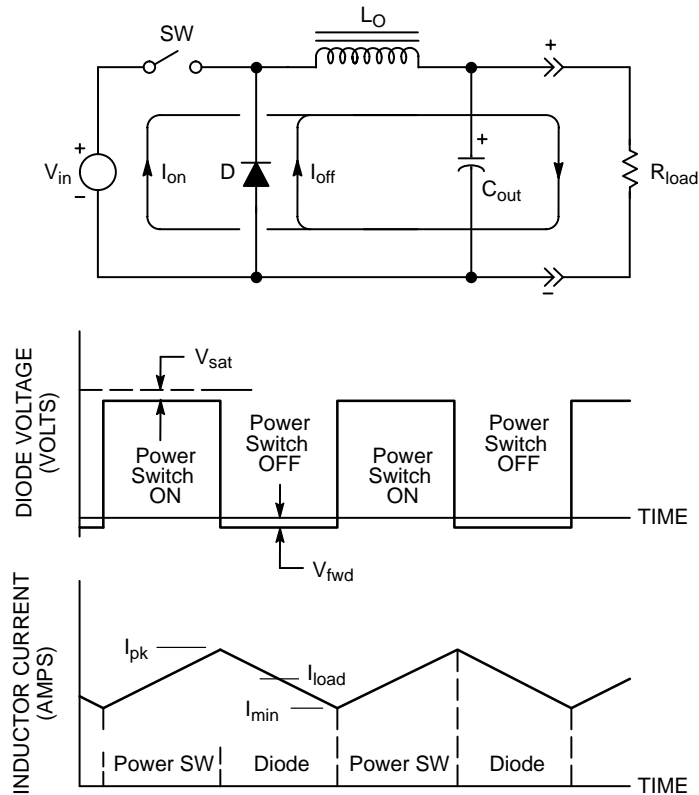
The forward-mode converter can be recognized by the presence of an L-C filter on its output. The L-C filter creates a DC output voltage, which is essentially the volt-time average of the L-C filter's input AC rectangular waveform. This can be expressed as:

$$V_{out} \approx V_{in} \cdot \text{duty cycle} \quad (\text{eq. 1})$$

The switching power supply controller varies the duty cycle of the input rectangular voltage waveform and thus controls the signal's volt-time average.

The *buck* or *step-down converter* is the simplest forward-mode converter, which is shown in Figure 1.

# SMPSRM



**Figure 1. A Basic Forward-Mode Converter and Waveforms (Buck Converter Shown)**

Its operation can be better understood when it is broken into two time periods: when the power switch is turned on and turned off. When the power switch is turned on, the input voltage is directly connected to the input of the L-C filter. Assuming that the converter is in a steady-state, there is the output voltage on the filter's output. The inductor current begins a linear ramp from an initial current dictated by the remaining flux in the inductor. The inductor current is given by:

$$i_{L(on)} = \frac{(V_{in} - V_{out})}{L}t + i_{init} \quad 0 \leq t \leq t_{on} \quad (\text{eq. 2})$$

During this period, energy is stored as magnetic flux within the core of the inductor. When the power switch is turned off, the core contains enough energy to supply the load during the following off period plus some reserve energy.

When the power switch turns off, the voltage on the input side of the inductor tries to fly below ground, but is

clamped when the *catch diode* D becomes forward biased. The stored energy then continues flowing to the output through the catch diode and the inductor. The inductor current decreases from an initial value  $i_{pk}$  and is given by:

$$i_{L(off)} = i_{pk} - \frac{V_{out}t}{L} \quad 0 \leq t \leq t_{off} \quad (\text{eq. 3})$$

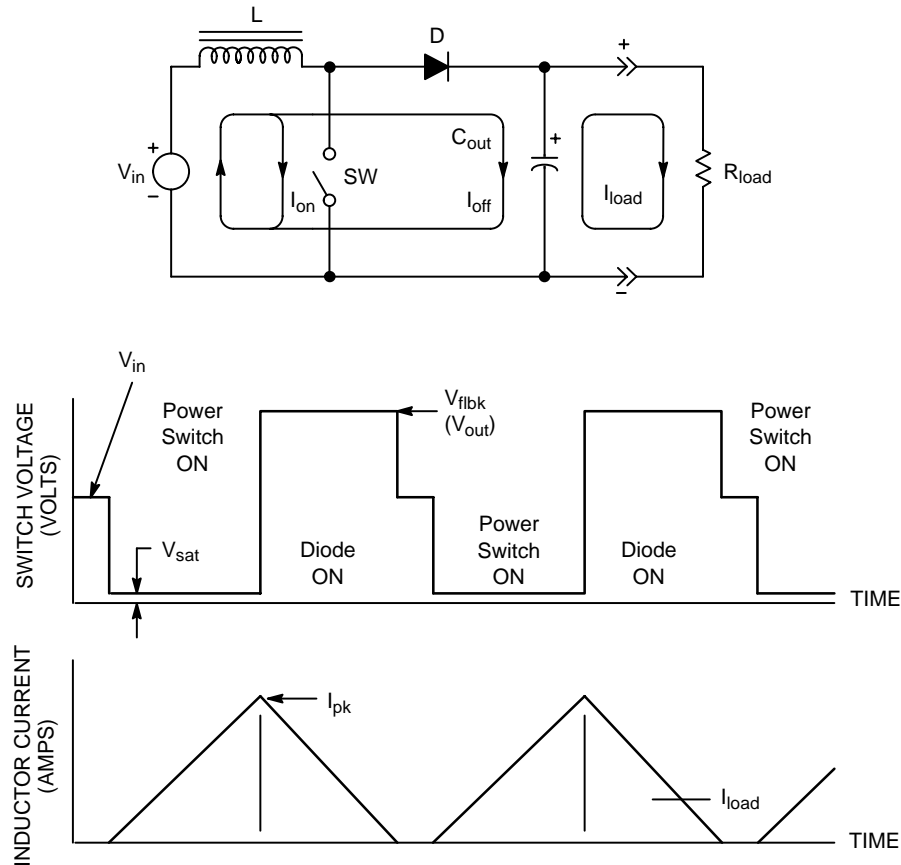
The off period continues until the controller turns the power switch back on and the cycle repeats itself.

The buck converter is capable of over one kilowatt of output power, but is typically used for on-board regulator applications whose output powers are less than 100 watts. Compared to the flyback-mode converter, the forward converter exhibits lower output peak-to-peak ripple voltage. The disadvantage is that it is a step-down topology only. Since it is not an isolated topology, for safety reasons the forward converter cannot be used for input voltages greater than 42.5 VDC.

**The Flyback–Mode Converter**

The basic flyback–mode converter uses the same components as the basic forward–mode converter, but in a different configuration. Consequently, it operates in a

different fashion from the forward–mode converter. The most elementary flyback–mode converter, the *boost* or *step–up converter*, is shown in Figure 2.



**Figure 2. A Basic Boost–Mode Converter and Waveforms (Boost Converter Shown)**

Again, its operation is best understood by considering the “on” and “off” periods separately. When the power switch is turned on, the inductor is connected directly across the input voltage source. The inductor current then rises from zero and is given by:

$$i_{L(on)} = \frac{V_{in}t}{L} \quad \leq t \leq 0_{on} \quad (\text{eq. 4})$$

Energy is stored within the flux in the core of the inductor. The peak current,  $i_{pk}$ , occurs at the instant the power switch is turned off and is given by:

$$i_{pk} = \frac{V_{in} t_{on}}{L} \quad (\text{eq. 5})$$

When the power switch turns off, the switched side of the inductor wants to fly–up in voltage, but is clamped by

the output rectifier when its voltage exceeds the output voltage. The energy within the core of the inductor is then passed to the output capacitor. The inductor current during the off period has a negative ramp whose slope is given by:

$$i_{L(off)} = \frac{(V_{in} - V_{out})}{L} \quad (\text{eq. 6})$$

The energy is then completely emptied into the output capacitor and the switched terminal of the inductor falls back to the level of the input voltage. Some ringing is evident during this time due to residual energy flowing through parasitic elements such as the stray inductances and capacitances in the circuit.



## SMPSRM

When there is some residual energy permitted to remain within the inductor core, the operation is called *continuous-mode*. This can be seen in Figure 3.

Energy for the entire on and off time periods must be stored within the inductor. The stored energy is defined by:

$$E_L = 0.5L \cdot i_{pk}^2 \quad (\text{eq. 7})$$

The boost-mode inductor must store enough energy to supply the output load for the entire switching period ( $t_{on} + t_{off}$ ). Also, boost-mode converters are typically limited

to a 50 percent duty cycle. There must be a time period when the inductor is permitted to empty itself of its energy.

The boost converter is used for board-level (i.e., non-isolated) step-up applications and is limited to less than 100–150 watts due to high peak currents. Being a non-isolated converter, it is limited to input voltages of less than 42.5 VDC. Replacing the inductor with a transformer results in a flyback converter, which may be step-up or step-down. The transformer also provides dielectric isolation from input to output.

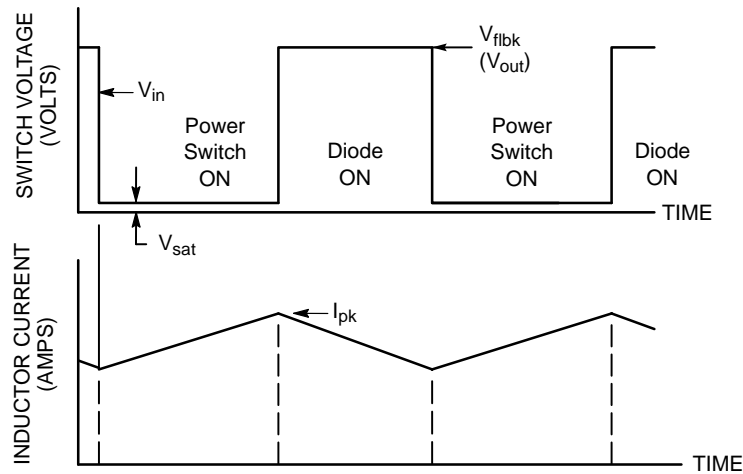


Figure 3. Waveforms for a Continuous-Mode Boost Converter

## Common Switching Power Supply Topologies

A topology is the arrangement of the power devices and their magnetic elements. Each topology has its own merits within certain applications. There are five major factors to consider when selecting a topology for a particular application. These are:

1. Is input-to-output dielectric isolation required for the application? This is typically dictated by the safety regulatory bodies in effect in the region.
2. Are multiple outputs required?
3. Does the prospective topology place a reasonable voltage stress across the power semiconductors?
4. Does the prospective topology place a reasonable current stress upon the power semiconductors?

5. How much of the input voltage is placed across the primary transformer winding or inductor?

Factor 1 is a safety-related issue. Input voltages above 42.5 VDC are considered hazardous by the safety regulatory agencies throughout the world. Therefore, only transformer-isolated topologies must be used above this voltage. These are the *off-line* applications where the power supply is plugged into an AC source such as a wall socket.

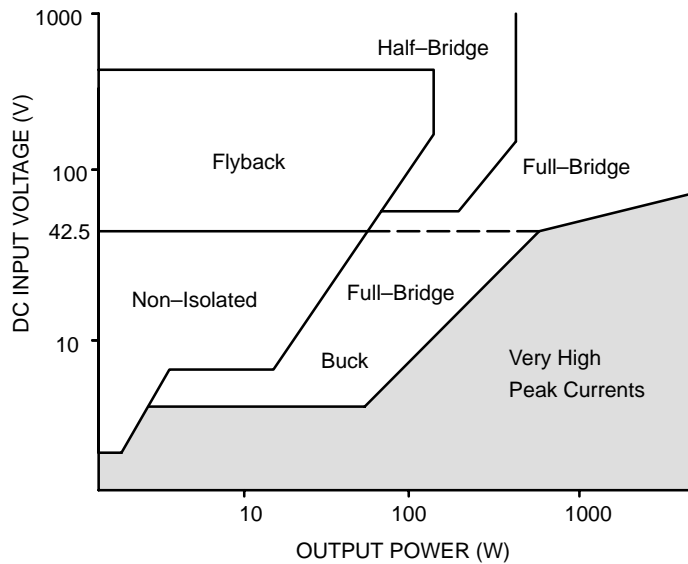
Multiple outputs require a transformer-based topology. The input and output grounds may be connected together if the input voltage is below 42.5 VDC. Otherwise full dielectric isolation is required.

Factors 3, 4 and 5 have a direct affect upon the reliability of the system. Switching power supplies deliver constant power to the output load. This power is then reflected back to the input, so at low input voltages, the input current must be high to maintain the output power. Conversely, the higher the input voltage, the lower the input current. The design goal is to place as much as possible of the input voltage across the transformer or inductor so as to minimize the input current.

Boost-mode topologies have peak currents that are about twice those found in forward-mode topologies. This makes them unusable at output powers greater than 100–150 watts.

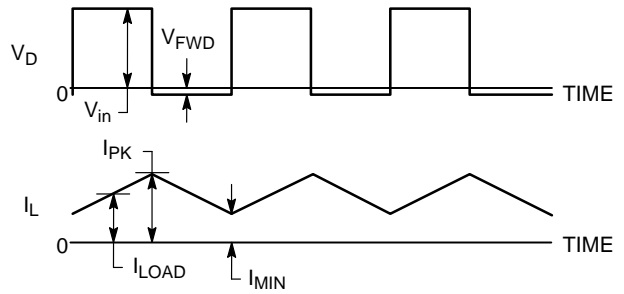
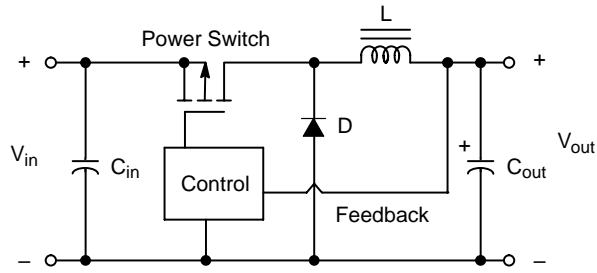
Cost is a major factor that enters into the topology decision. There are large overlaps in the performance boundaries between the topologies. Sometimes the most cost-effective choice is to purposely design one topology to operate in a region that usually is performed by another. This, though, may affect the reliability of the desired topology.

Figure 4 shows where the common topologies are used for a given level of DC input voltage and required output power. Figures 5 through 12 show the common topologies. There are more topologies than shown, such as the Sepic and the Cuk, but they are not commonly used.

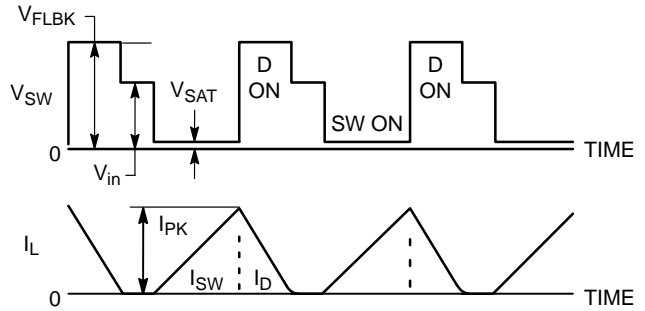
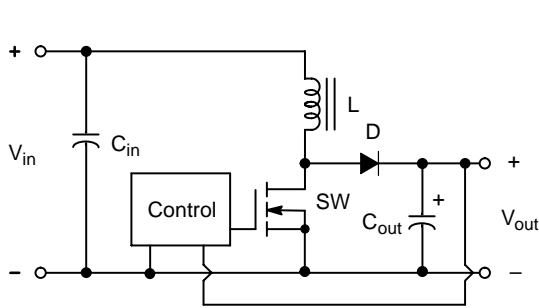


**Figure 4. Where Various Topologies Are Used**

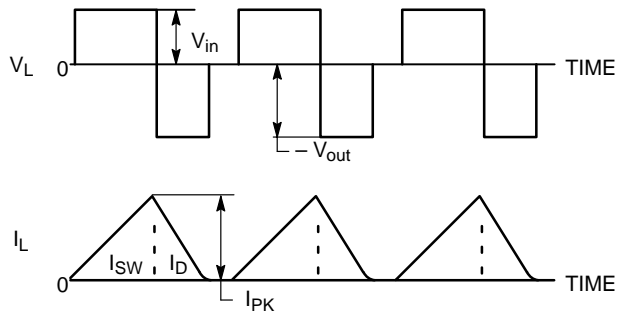
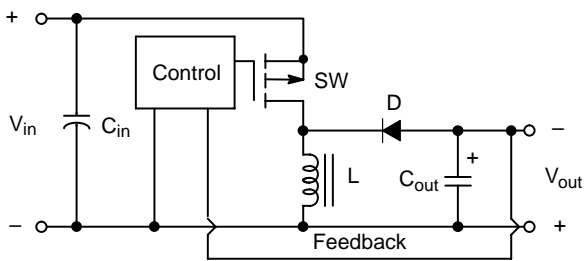
**SMPSRM**



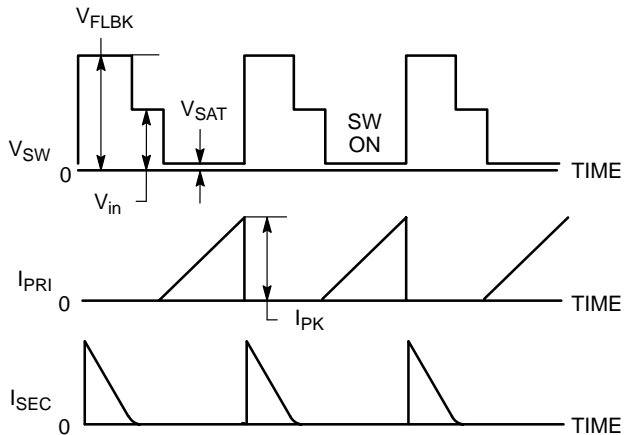
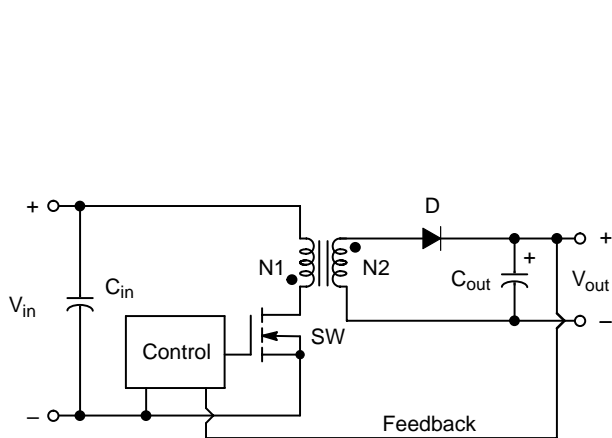
**Figure 5. The Buck (Step-Down) Converter**



**Figure 6. The Boost (Step-Up) Converter**



**Figure 7. The Buck-Boost (Inverting) Converter**



**Figure 8. The Flyback Converter**

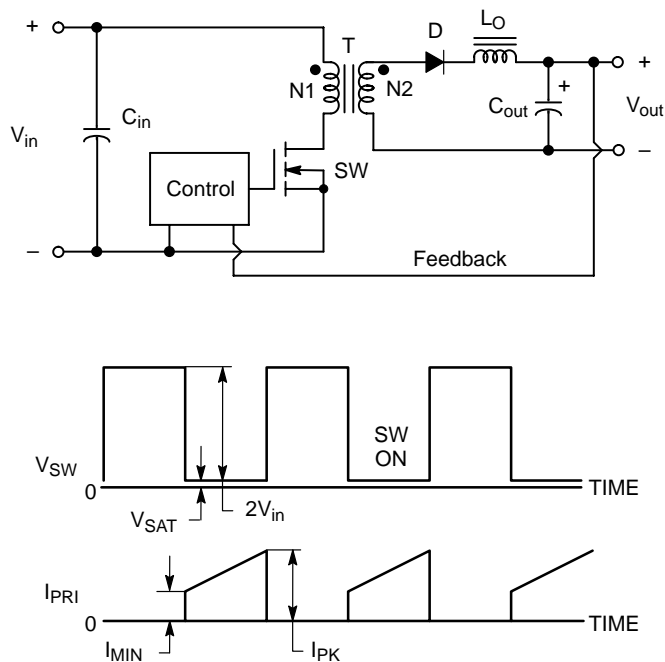


Figure 9. The One-Transistor Forward Converter (Half Forward Converter)

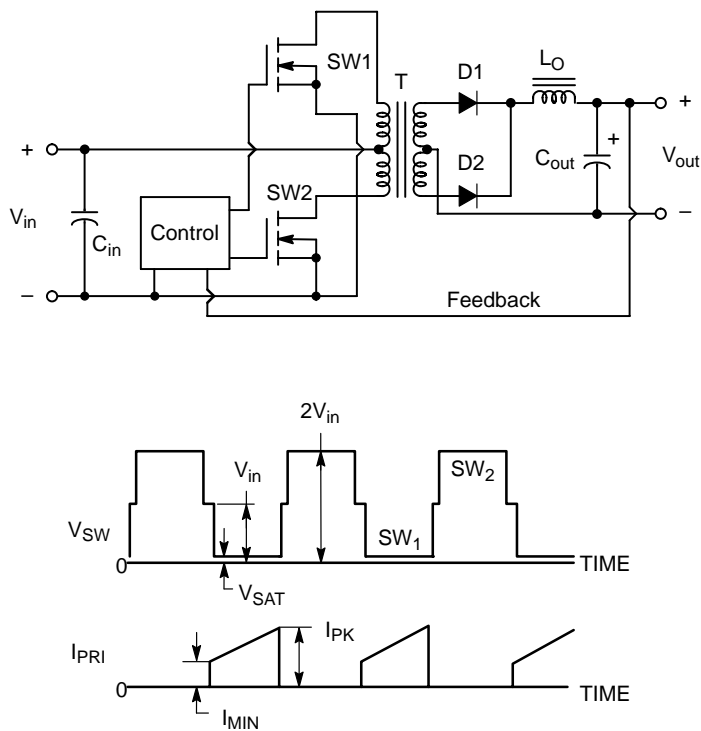
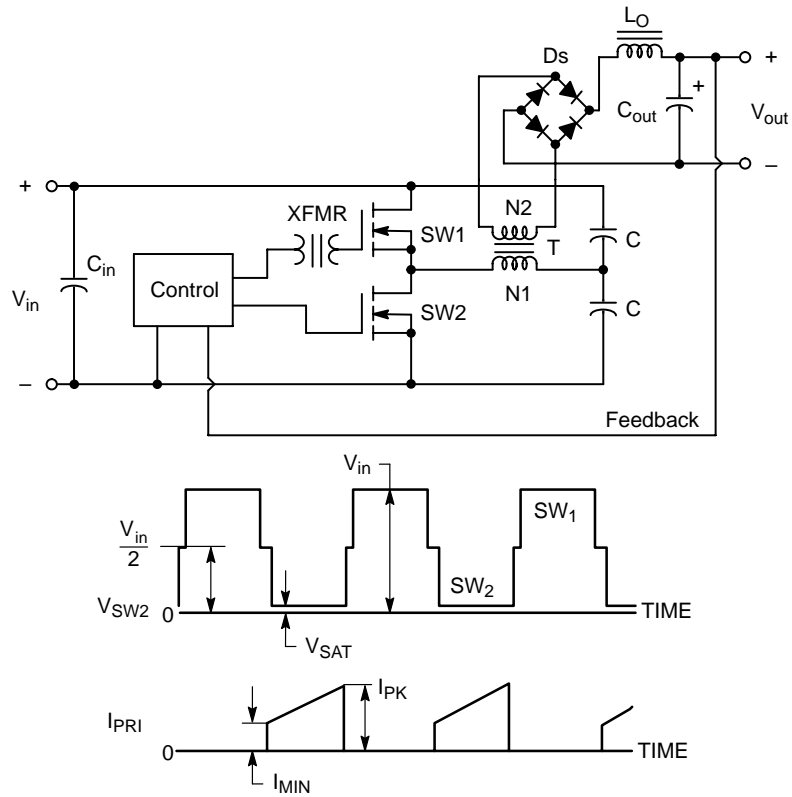
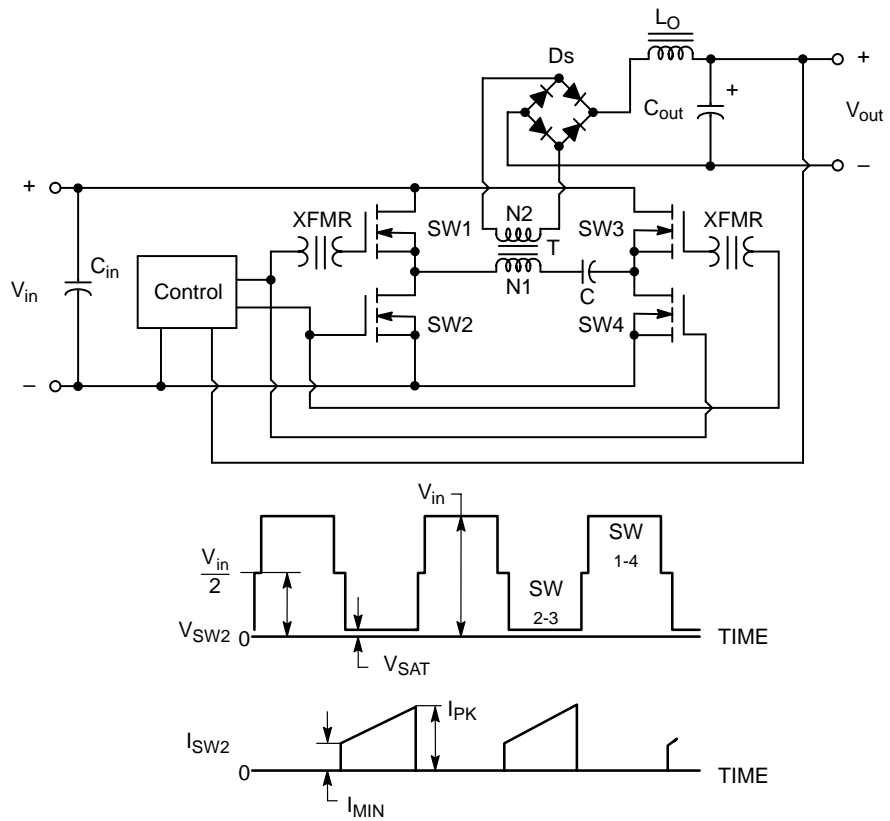


Figure 10. The Push-Pull Converter

**SMPSRM**



**Figure 11. The Half-Bridge Converter**



**Figure 12. The Full-Bridge Converter**

### Interleaved Multiphase Converters

One method of increasing the output power of any topology and reducing the stresses upon the semiconductors, is a technique called interleaving. Any topology can be interleaved. An *interleaved multiphase* converter has two or more identical converters placed in parallel which share key components. For an  $n$ -phase converter, each converter is driven at a phase difference of  $360/n$  degrees from the next. The output current from all the phases sum together at the output, requiring only  $I_{out}/n$  amperes from each phase.

The input and output capacitors are shared among the phases. The input capacitor sees less RMS ripple current because the peak currents are less and the combined duty cycle of the phases is greater than it would experience with a single phase converter. The output capacitor can be made smaller because the frequency of current waveform is  $n$ -times higher and its combined duty cycle is greater. The semiconductors also see less current stress.

A block diagram of an interleaved multiphase buck converter is shown in Figure 13. This is a 2-phase topology that is useful in providing power to a high performance microprocessor.

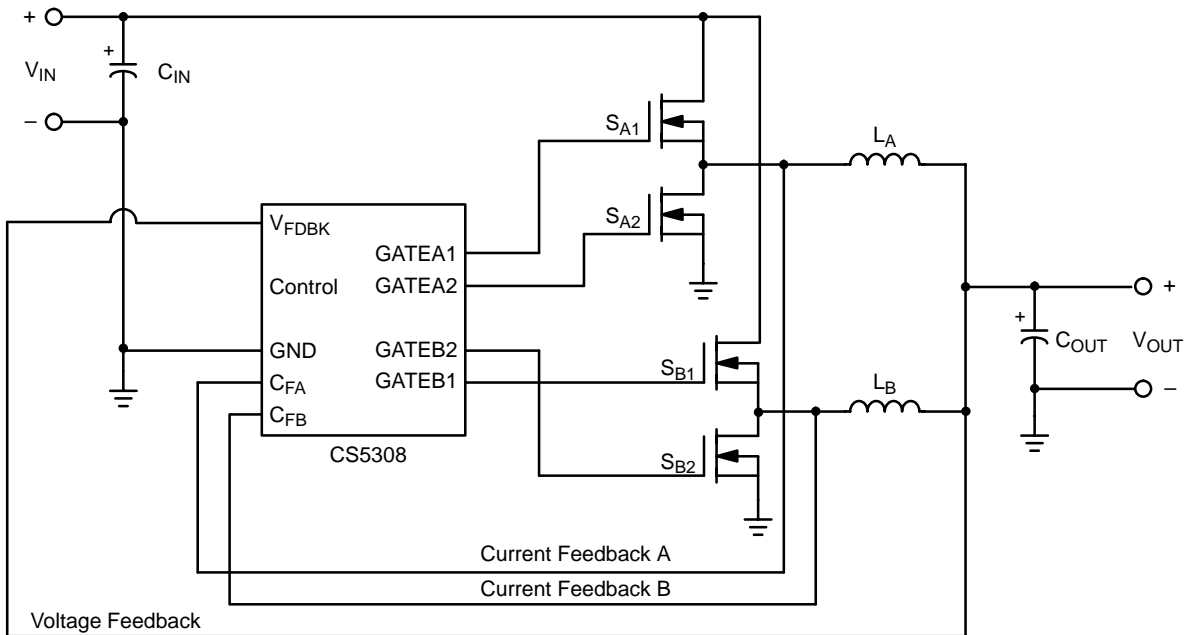


Figure 13. Example of a Two-Phase Buck Converter with Voltage and Current Feedback

## SMPSRM

### Selecting the Method of Control

There are three major methods of controlling a switching power supply. There are also variations of these control methods that provide additional protection features. One should review these methods carefully and then carefully review the controller IC data sheets to

select the one that is wanted.

Table 1 summarizes the features of each of the popular methods of control. Certain methods are better adapted to certain topologies due to reasons of stability or transient response.

**Table 1. Common Control Methods Used in ICs**

Control Method	OC Protection	Response Time	Preferred Topologies
Voltage-Mode	Average OC	Slow	Forward-Mode
	Pulse-by-Pulse OC	Slow	Forward-Mode
Current-Mode	Intrinsic	Rapid	Boost-Mode
	Hysteretic	Rapid	Boost & Forward-Mode
Hysteric Voltage	Average	Slow	Boost & Forward-Mode

*Voltage-mode control* (see Figure 14) is typically used for forward-mode topologies. In voltage-mode control, only the output voltage is monitored. A voltage error signal is calculated by forming the difference between  $V_{out}$  (actual) and  $V_{out}(\text{desired})$ . This error signal is then fed into a comparator that compares it to the ramp voltage generated by the internal oscillator section of the control IC. The comparator thus converts the voltage error signal into the PWM drive signal to the power switch. Since the only control parameter is the output voltage, and there is inherent delay through the power circuit, voltage-mode control tends to respond slowly to input variations.

Overcurrent protection for a voltage-mode controlled converter can either be based on the average output current or use a pulse-by-pulse method. In *average overcurrent protection*, the DC output current is monitored, and if a threshold is exceeded, the pulse width of the power switch is reduced. In *pulse-by-pulse overcurrent protection*, the peak current of each power switch “on” cycle is monitored and the power switch is

instantly cutoff if its limits are exceeded. This offers better protection to the power switch.

*Current-mode control* (see Figure 15) is typically used with boost-mode converters. Current-mode control monitors not only the output voltage, but also the output current. Here the voltage error signal is used to control the peak current within the magnetic elements during each power switch on-time. Current-mode control has a very rapid input and output response time, and has an inherent overcurrent protection. It is not commonly used for forward-mode converters; their current waveforms have much lower slopes in their current waveforms which can create jitter within comparators.

*Hysteretic control* is a method of control which tries to keep a monitored parameter between two limits. There are hysteretic current and voltage control methods, but they are not commonly used.

The designer should be very careful when reviewing a prospective control IC data sheet. The method of control and any variations are usually not clearly described on the first page of the data sheet.

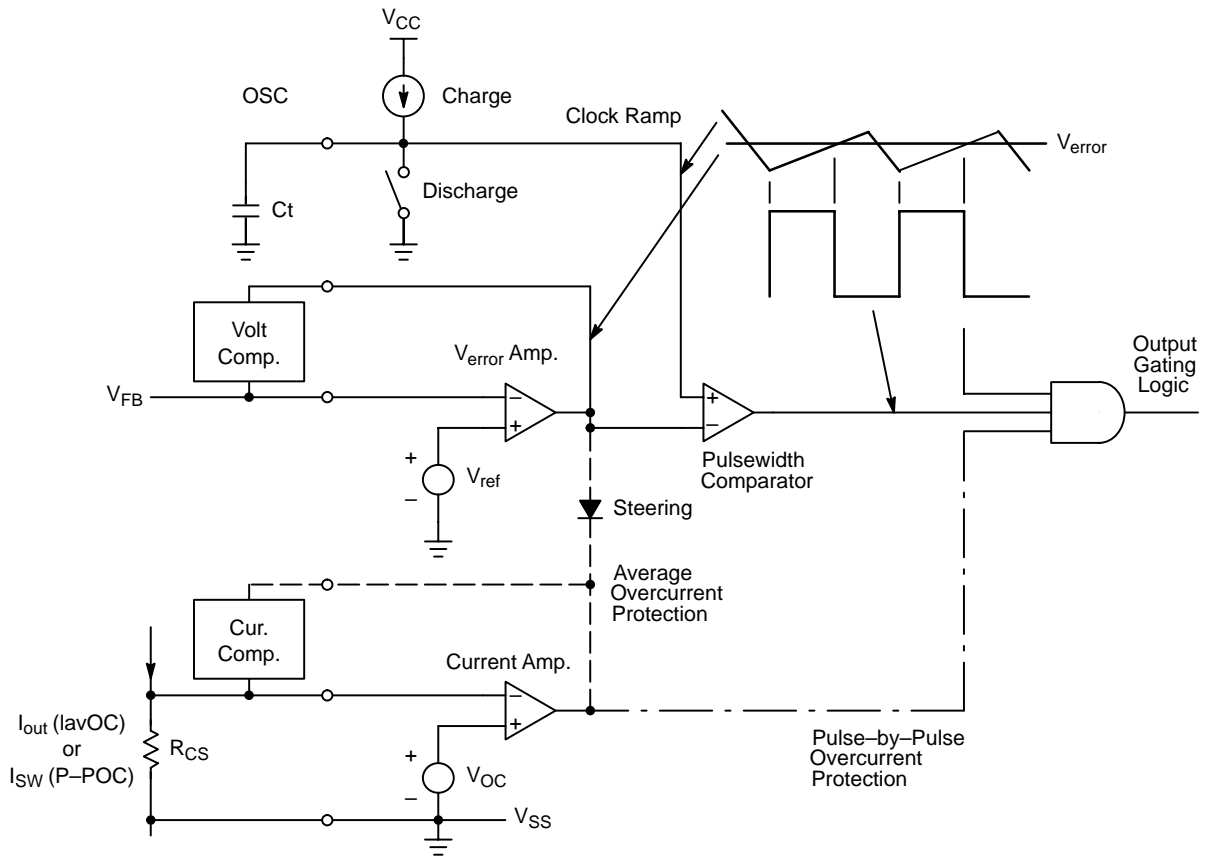


Figure 14. Voltage-Mode Control

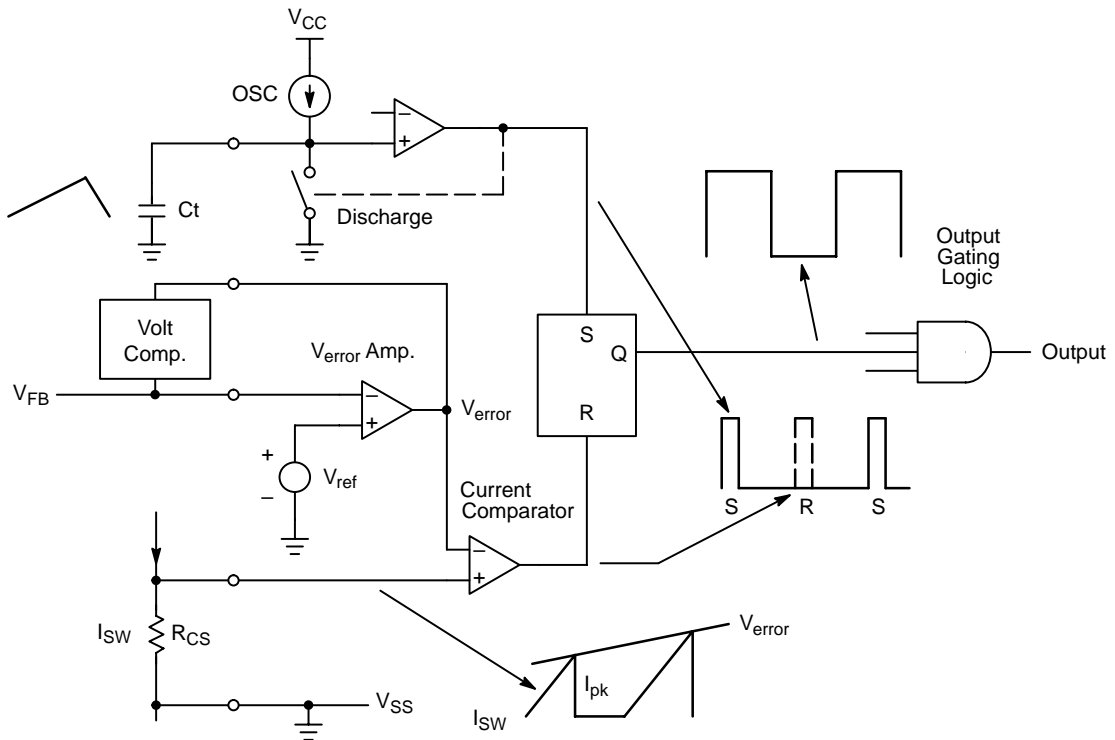


Figure 15. Turn-On with Clock Current-Mode Control



## The Choice of Semiconductors Power Switches

The choice of which semiconductor technology to use for the power switch function is influenced by many factors such as cost, peak voltage and current, frequency of operation, and heatsinking. Each technology has its own peculiarities that must be addressed during the design phase.

There are three major power switch choices: the bipolar junction transistor (BJT), the power MOSFET, and the integrated gate bipolar transistor (IGBT). The BJT was the first power switch to be used in this field and still offers many cost advantages over the others. It is also still used for very low cost or in high power switching converters. The maximum frequency of operation of bipolar transistors is less than 80–100 kHz because of some of their switching characteristics. The IGBT is used for high power switching converters, displacing many of the BJT applications. They too, though, have a slower switching characteristic which limits their frequency of operation to below 30 kHz typically although some can reach 100 kHz. IGBTs have smaller die areas than power MOSFETs of the same ratings, which typically means a lower cost. Power MOSFETs are used in the majority of applications due to their ease of use and their higher frequency capabilities. Each of the technologies will be reviewed.

### The Bipolar Power Transistor

The BJT is a current driven device. That means that the base current is in proportion to the current drawn through the collector. So one must provide:

$$I_B > I_C / h_{FE} \quad (\text{eq. 8})$$

In power transistors, the average gain ( $h_{FE}$ ) exhibited at the higher collector currents is between 5 and 20. This could create a large base drive loss if the base drive circuit is not properly designed.

One should generate a gate drive voltage that is as close to 0.7 volts as possible. This is to minimize any loss created by dropping the base drive voltage at the required base current to the level exhibited by the base.

A second consideration is the *storage time* exhibited by the collector during its turn-off transition. When the base is overdriven, or where the base current is more than needed to sustain the collector current, the collector exhibits a 0.3–2  $\mu\text{s}$  delay in its turn-off which is proportional to the base overdrive. Although the storage time is not a major source of loss, it does significantly limit the maximum switching frequency of a bipolar-based switching power supply. There are two methods of reducing the storage time and increasing its switching time. The first is to use a base speed-up capacitor whose value, typically around 100 pF, is placed in parallel with the base current limiting resistor (Figure 16a). The second is to use proportional base drive (Figure 16b). Here, only the amount of needed base current is provided by the drive circuit by bleeding the excess around the base into the collector.

The last consideration with BJTs is the risk of excessive *second breakdown*. This phenomenon is caused by the resistance of the base across the die, permitting the furthest portions of the collector to turn off later. This forces the current being forced through the collector by an inductive load, to concentrate at the opposite ends of the die, thus causing an excessive localized heating on the die. This can result in a short-circuit failure of the BJT which can happen instantaneously if the amount of current crowding is great, or it can happen later if the amount of heating is less. Current crowding is always present when an inductive load is attached to the collector. By switching the BJT faster, with the circuits in Figure 15, one can greatly reduce the effects of second breakdown on the reliability of the device.

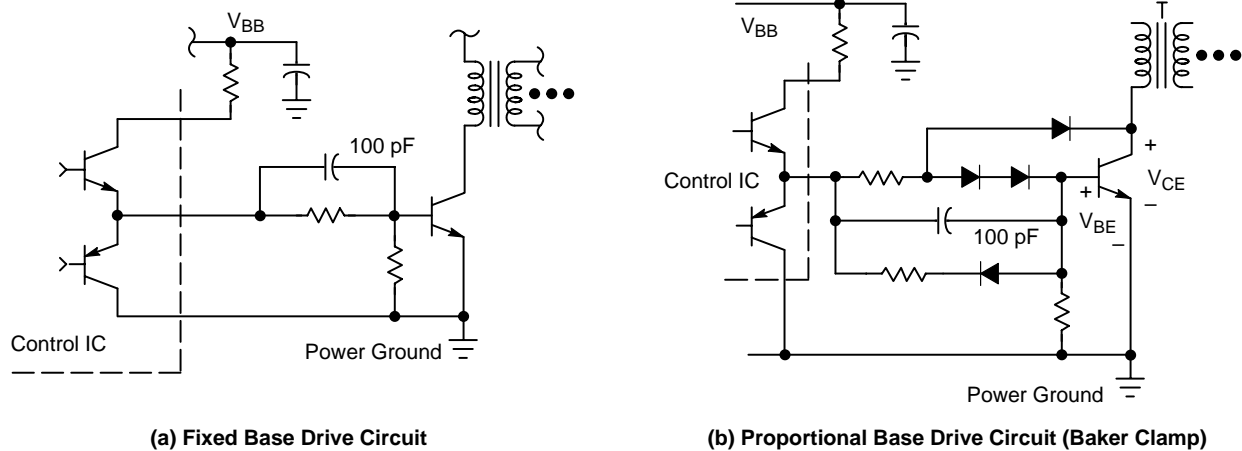


Figure 16. Driving a Bipolar Junction Transistor

### The Power MOSFET

Power MOSFETs are the popular choices used as power switches and synchronous rectifiers. They are, on the surface, simpler to use than BJTs, but they have some hidden complexities.

A simplified model for a MOSFET can be seen in Figure 17. The capacitances seen in the model are specified within the MOSFET data sheets, but can be nonlinear and vary with their applied voltages.

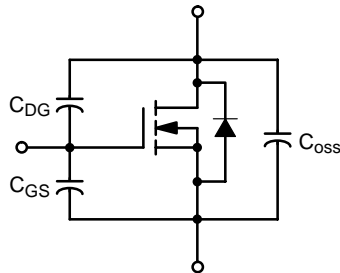


Figure 17. The MOSFET Model

From the gate terminal, there are two capacitances the designer encounters, the gate input capacitance ( $C_{iSS}$ ) and the drain–gate reverse capacitance ( $C_{rSS}$ ). The gate input capacitance is a fixed value caused by the capacitance formed between the gate metalization and the substrate. Its value usually falls in the range of 800–3200 pF, depending upon the physical construction of the MOSFET. The  $C_{rSS}$  is the capacitance between the drain and the gate, and has values in the range of 60–150 pF. Although the  $C_{rSS}$  is smaller, it has a much more pronounced effect upon the gate drive. It couples the drain voltage to the gate, thus dumping its stored charge into the gate input capacitance. The typical gate drive waveforms can be seen in Figure 18. Time period  $t_1$  is only the  $C_{iSS}$  being charged or discharged by the impedance of the external gate drive circuit. Period  $t_2$  shows the effect of the changing drain voltage being coupled into the gate through  $C_{rSS}$ . One can readily observe the “flattening” of the gate drive voltage during this period, both during the turn–on and turn–off of the MOSFET. Time period  $t_3$  is the amount of overdrive voltage provided by the drive circuit but not really needed by the MOSFET.

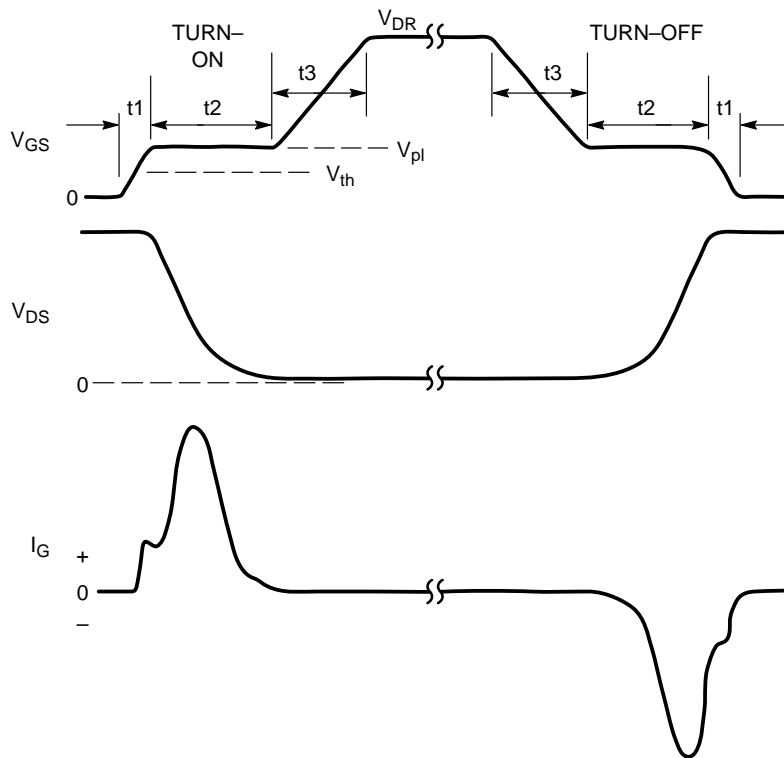


Figure 18. Typical MOSFET Drive Waveforms (Top:  $V_{GS}$ , Middle:  $V_{DG}$ , Bottom:  $I_G$ )

## SMPSRM

The time needed to switch the MOSFET between on and off states is dependent upon the impedance of the gate drive circuit. It is very important that the drive circuit be bypassed with a capacitor that will keep the drive voltage constant over the drive period. A 0.1  $\mu\text{F}$  capacitor is more than sufficient.

## Driving MOSFETs in Switching Power Supply Applications

There are three things that are very important in the high frequency driving of MOSFETs: there must be a totem-pole driver; the drive voltage source must be well bypassed; and the drive devices must be able to source high levels of current in very short periods of time (low compliance). The optimal drive circuit is shown in Figure 19.

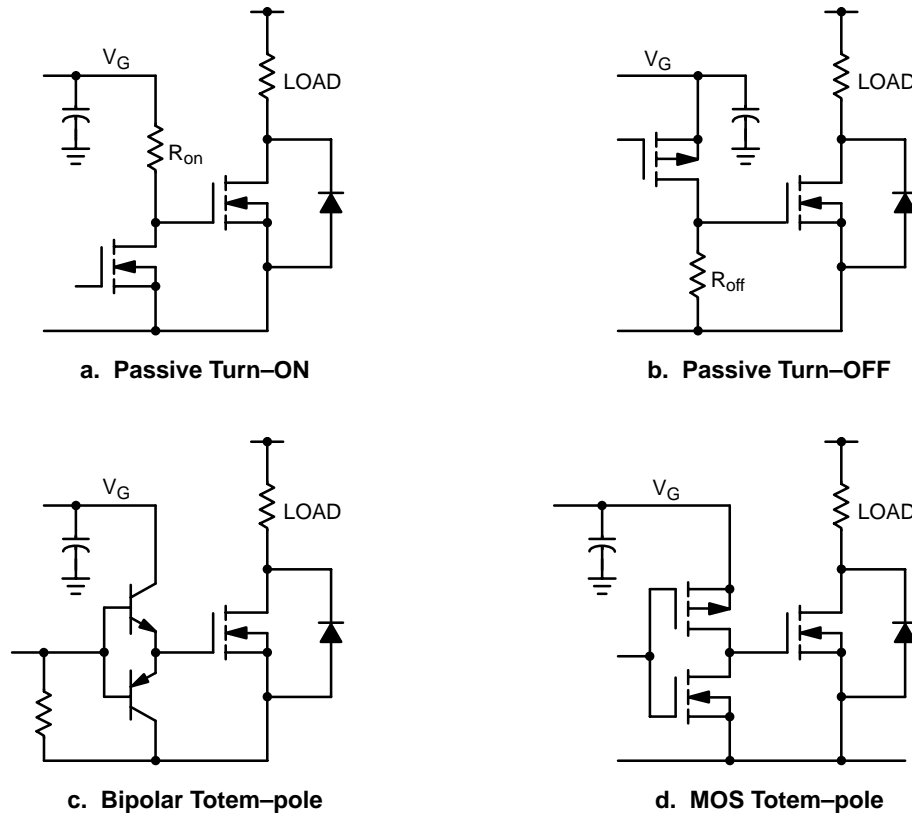


Figure 19. Bipolar and FET-Based Drive Circuits (a. Bipolar Drivers, b. MOSFET Drivers)

Sometimes it is necessary to provide a dielectrically-isolated drive to a MOSFET. This is provided by a drive transformer. Transformers driven from a DC source must be capacitively coupled from the totem-pole driver circuit. The secondary winding must be capacitively coupled to the gate with a DC restoration

circuit. Both of the series capacitors must be more than 10 times the value of the  $C_{iss}$  of the MOSFET so that the capacitive voltage divider that is formed by the series capacitors does not cause an excessive attenuation. The circuit can be seen in Figure 20.

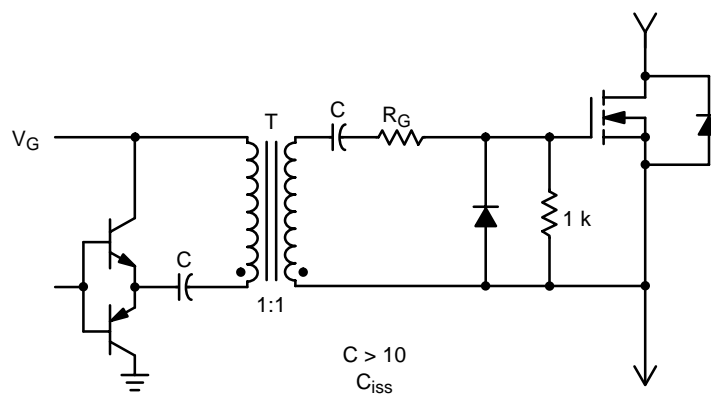


Figure 20. Transformer-Isolated Gate Drive

## The Insulated Gate Bipolar Transistor (IGBT)

The IGBT is a hybrid device with a MOSFET as the input device, which then drives a silicon-controlled rectifier (SCR) as a switched output device. The SCR is constructed such that it does not exhibit the latching characteristic of a typical SCR by making its feedback gain less than 1. The die area of the typical IGBT is less than one-half that of an identically rated power MOSFET, which makes it less expensive for high-power converters. The only drawback is the turn-off characteristic of the IGBT. Being a bipolar minority carrier device, charges must be removed from the P-N junctions during a turn-off condition. This causes a “current tail” at the end of the turn-off transition of the current waveform. This can be a significant loss because the voltage across the IGBT is very high at that moment. This makes the IGBT useful only for frequencies typically less than 20 kHz, or for exceptional IGBTs, 100 kHz.

To drive an IGBT one uses the MOSFET drive circuits shown in Figures 18 and 19. Driving the IGBT gate faster makes very little difference in the performance of an IGBT, so some reduction in drive currents can be used.

The voltage drop of across the collector-to-emitter ( $V_{CE}$ ) terminals is comparable to those found in Darlington BJTs and MOSFETs operated at high currents. The typical  $V_{CE}$  of an IGBT is a flat 1.5–2.2 volts. MOSFETs, acting more resistive, can have voltage drops of up to 5 volts at the end of some high current ramps. This makes the IGBT, in high current environments, very comparable to MOSFETs in applications of less than 5–30 kHz.

## Rectifiers

Rectifiers represent about 60 percent of the losses in nonsynchronous switching power supplies. Their choice has a very large effect on the efficiency of the power supply.

The significant rectifier parameters that affect the operation of switching power supplies are:

- *forward voltage drop* ( $V_f$ ), which is the voltage across the diode when a forward current is flowing
- the *reverse recovery time* ( $t_{rr}$ ), which is how long it requires a diode to clear the minority charges from its junction area and turn off when a reverse voltage is applied
- the *forward recovery time* ( $t_{fr}$ ) which is how long it take a diode to begin to conduct forward current after a forward voltage is applied.

There are four choices of rectifier technologies: standard, fast and ultra-fast recovery types, and Schottky barrier types.

A **standard recovery diode** is only suitable for 50–60 Hz rectification due to its slow turn-off characteristics. These include common families such as the 1N4000 series diodes. **Fast-recovery diodes** were first used in switching power supplies, but their turn-off time is considered too slow for most modern applications. They may find application where low cost is paramount, however. **Ultra-fast recovery diodes** turn off quickly and have a forward voltage drop of 0.8 to 1.3 V, together with a high reverse voltage capability of up to 1000 V. A **Schottky rectifier** turns off very quickly and has an average forward voltage drop of between 0.35 and 0.8 V, but has a low reverse breakdown voltage and

## SMPSRM

a high reverse leakage current. For a typical switching power supply application, the best choice is usually a Schottky rectifier for output voltages less than 12 V, and an ultra-fast recovery diode for all other output voltages.

The major losses within output rectifiers are conduction losses and switching losses. The conduction loss is the forward voltage drop times the current flowing through it during its conduction period. This can be significant if its voltage drop and current are high. The switching losses are determined by how fast a diode turns off ( $t_{rr}$ ) times the reverse voltage across the rectifier. This can be significant for high output voltages and currents.

The characteristics of power rectifiers and their applications in switching power supplies are covered in great detail in Reference (5).

The major losses within output rectifiers are conduction losses and switching losses. The conduction loss is the forward voltage drop times the current flowing through it during its conduction period. This can be significant if its voltage drop and current are high. The switching losses are determined by how fast a diode turns off ( $t_{rr}$ ) times the reverse voltage across the rectifier. This can be significant for high output voltages and currents.

**Table 2. Types of Rectifier Technologies**

Rectifier Type	Average $V_f$	Reverse Recovery Time	Typical Applications
Standard Recovery	0.7–1.0 V	1,000 ns	50–60 Hz Rectification
Fast Recovery	1.0–1.2 V	150–200 ns	Output Rectification
UltraFast Recovery	0.9–1.4 V	25–75 ns	Output Rectification ( $V_o > 12$ V)
Schottky	0.3–0.8 V	< 10 ns	Output Rectification ( $V_o < 12$ V)

**Table 3. Estimating the Significant Parameters of the Power Semiconductors**

Topology	Bipolar Pwr Sw		MOSFET Pwr Sw		Rectifier	
	$V_{CEO}$	$I_c$	$V_{DSS}$	$I_D$	$V_R$	$I_F$
Buck	$V_{in}$	$I_{out}$	$V_{in}$	$I_{out}$	$V_{in}$	$I_{out}$
Boost	$V_{out}$	$\frac{(2.0 P_{out})}{V_{in(min)}}$	$V_{out}$	$\frac{(2.0 P_{out})}{V_{in(min)}}$	$V_{out}$	$I_{out}$
Buck/Boost	$V_{in} - V_{out}$	$\frac{(2.0 P_{out})}{V_{in(min)}}$	$V_{in} - V_{out}$	$\frac{(2.0 P_{out})}{V_{in(min)}}$	$V_{in} - V_{out}$	$I_{out}$
Flyback	$1.7 V_{in(max)}$	$\frac{(2.0 P_{out})}{V_{in(min)}}$	$1.5 V_{in(max)}$	$\frac{(2.0 P_{out})}{V_{in(min)}}$	$5.0 V_{out}$	$I_{out}$
1 Transistor Forward	$2.0 V_{in}$	$\frac{(1.5 P_{out})}{V_{in(min)}}$	$2.0 V_{in}$	$\frac{(1.5 P_{out})}{V_{in(min)}}$	$3.0 V_{out}$	$I_{out}$
Push–Pull	$2.0 V_{in}$	$\frac{(1.2 P_{out})}{V_{in(min)}}$	$2.0 V_{in}$	$\frac{(1.2 P_{out})}{V_{in(min)}}$	$2.0 V_{out}$	$I_{out}$
Half–Bridge	$V_{in}$	$\frac{(2.0 P_{out})}{V_{in(min)}}$	$V_{in}$	$\frac{(2.0 P_{out})}{V_{in(min)}}$	$2.0 V_{out}$	$I_{out}$
Full–Bridge	$V_{in}$	$\frac{(1.2 P_{out})}{V_{in(min)}}$	$V_{in}$	$\frac{(2.0 P_{out})}{V_{in(min)}}$	$2.0 V_{out}$	$I_{out}$

## The Magnetic Components

The magnetic elements within a switching power supply are used either for stepping-up or down a switched AC voltage, or for energy storage. In forward-mode topologies, the transformer is only used for stepping-up or down the AC voltage generated by the power switches. The output filter (the output inductor and capacitor) in forward-mode topologies is used for energy storage. In boost-mode topologies, the transformer is used both for energy storage and to provide a step-up or step-down function.

Many design engineers consider the magnetic elements of switching power supplies counter-intuitive or too complicated to design. Fortunately, help is at hand; the suppliers of magnetic components have applications engineers who are quite capable of performing the transformer design and discussing the tradeoffs needed for success. For those who are more experienced or more adventuresome, please refer to Reference 2 in the Bibliography for transformer design guidelines.

The general procedure in the design of any magnetic component is as follows (Reference 2, p 42):

1. Select an appropriate core material for the application and the frequency of operation.
2. Select a core form factor that is appropriate for the application and that satisfies applicable regulatory requirements.
3. Determine the core cross-sectional area necessary to handle the required power
4. Determine whether an airgap is needed and calculate the number of turns needed for each winding. Then determine whether the accuracy of the output voltages meets the requirements and whether the windings will fit into the selected core size.
5. Wind the magnetic component using proper winding techniques.
6. During the prototype stage, verify the component's operation with respect to the level of voltage spikes, cross-regulation, output accuracy and ripple, RFI, etc., and make corrections were necessary.

The design of any magnetic component is a "calculated estimate." There are methods of "stretching" the design limits for smaller size or lower losses, but these tend to be diametrically opposed to one another. One should be cautious when doing this.

Some useful sources for magnetics components are:

### CoilCraft, Inc.

1102 Silver Lake Rd.  
Cary, IL (USA) 60013  
website: <http://www.coilcraft.com/>  
email: [info@coilcraft.com](mailto:info@coilcraft.com)  
Telephone: 847-639-6400

### Coiltronics, Division of Cooper Electronics Technology

6000 Park of Commerce Blvd  
Boca Raton, FL (USA) 33487  
website: <http://www.coiltronics.com>  
Telephone: 561-241-7876

### Cramer Coil, Inc.

401 Progress Dr.  
Saukville, WI (USA) 53080  
website: <http://www.cramerco.com>  
email: [techsales@cramercoil.com](mailto:techsales@cramercoil.com)  
Telephone: 262-268-2150

### Pulse, Inc.

San Diego, CA  
website: <http://www.pulseeng.com>  
Telephone: 858-674-8100

### TDK

1600 Feehanville Drive  
Mount Prospect, IL 60056  
website: <http://www.component.talk.com>  
Telephone: 847-803-6100

## Laying Out the Printed Circuit Board

The printed circuit board (PCB) layout is the third critical portion of every switching power supply design in addition to the basic design and the magnetics design. Improper layout can adversely affect RFI radiation, component reliability, efficiency and stability. Every PCB layout will be different, but if the designer appreciates the common factors present in all switching power supplies, the process will be simplified.

All PCB traces exhibit inductance and resistance. These can cause high voltage transitions whenever there is a high rate of change in current flowing through the trace. For operational amplifiers sharing a trace with power signals, it means that the supply would be impossible to stabilize. For traces that are too narrow for the current flowing through them, it means a voltage drop from one end of the trace to the other which potentially can be an antenna for RFI. In addition, capacitive coupling between adjacent traces can interfere with proper circuit operation.

There are two rules of thumb for PCB layouts: "short and fat" for all power-carrying traces and "one point grounding" for the various ground systems within a switching power supply. Traces that are short and fat minimize the inductive and resistive aspects of the trace, thus reducing noise within the circuits and RFI. Single-point grounding keeps the noise sources separated from the sensitive control circuits.

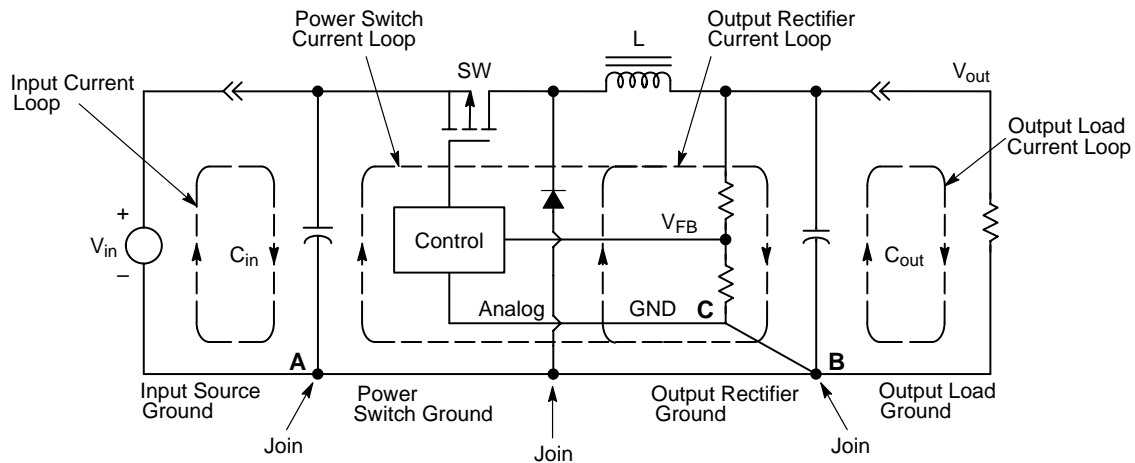
## SMPSRM

Within all switching power supplies, there are four major current loops. Two of the loops conduct the high-level AC currents needed by the supply. These are the power switch AC current loop and the output rectifier AC current loop. The currents are the typical trapezoidal current pulses with very high peak currents and very rapid di/dts. The other two current loops are the input source and the output load current loops, which carry low frequency current being supplied from the voltage source and to the load respectively.

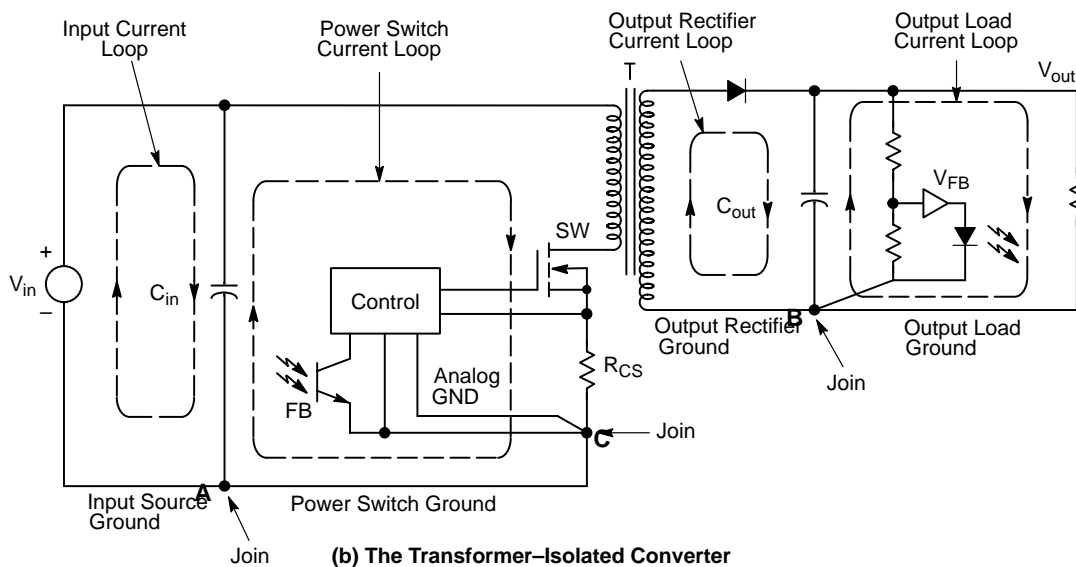
For the power switch AC current loop, current flows from the input filter capacitor through the inductor or transformer winding, through the power switch and back to the negative pin of the input capacitor. Similarly, the output rectifier current loop's current flows from the inductor or secondary transformer winding, through the

rectifier to the output filter capacitor and back to the inductor or winding. The filter capacitors are the only components that can source and sink the large levels of AC current in the time needed by the switching power supply. The PCB traces should be made as wide and as short as possible, to minimize resistive and inductive effects. These traces should be the first to be laid out.

Turning to the input source and output load current loops, both of these loops must be connected directly to their respective filter capacitor's terminals, otherwise switching noise could bypass the filtering action of the capacitor and escape into the environment. This noise is called conducted interference. These loops can be seen in Figure 21 for the two major forms of switching power supplies, non-isolated (Figure 21a) and transformer-isolated (Figure 21b).



(a) The Non-Isolated DC/DC Converter



(b) The Transformer-Isolated Converter

Figure 21. The Current Loops and Grounds for the Major Converter Topologies

The grounds are extremely important to the proper operation of the switching power supply, since they form the reference connections for the entire supply; each ground has its own unique set of signals which can adversely affect the operation of the supply if connected improperly.

There are five distinct grounds within the typical switching power supply. Four of them form the return paths for the current loops described above. The remaining ground is the low-level analog control ground which is critical for the proper operation of the supply. The grounds which are part of the major current loops must be connected together exactly as shown in Figure 21. Here again, the connecting point between the high-level AC grounds and the input or output grounds is at the negative terminal of the appropriate filter capacitor (points A and B in Figures 21a and 21b). Noise on the AC grounds can very easily escape into the environment if the grounds are not directly connected to the negative terminal of the filter capacitor(s). The analog control ground must be connected to the point where the control IC and associated circuitry must measure key power parameters, such as AC or DC current and the output voltage (point C in Figures 21a and 21b). Here any noise introduced by large AC signals within the AC grounds will sum directly onto the low-level control parameters and greatly affect the operation of the supply. The purpose of connecting the control ground to the lower side of the current sensing resistor or the output voltage resistor divider is to form a “Kelvin contact” where any common mode noise is not sensed by the control circuit. In short, follow the example given by Figure 21 exactly as shown for best results.

The last important factor in the PCB design is the layout surrounding the AC voltage nodes. These are the drain of the power MOSFET (or collector of a BJT) and the anode of the output rectifier(s). These nodes can capacitively couple into any trace on different layers of the PCB that run underneath the AC pad. In surface mount designs, these nodes also need to be large enough to provide heatsinking for the power switch or rectifier. This is at odds with the desire to keep the pad as small as possible to discourage capacitive coupling to other traces. One good compromise is to make all layers below the AC node identical to the AC node and connect them with many vias (plated-through holes). This greatly increases the thermal mass of the pad for improved heatsinking and locates any surrounding traces off laterally where the coupling capacitance is much smaller. An example of this can be seen in Figure 22.

Many times it is necessary to parallel filter capacitors to reduce the amount of RMS ripple current each capacitor experiences. Close attention should be paid to this layout. If the paralleled capacitors are in a line, the capacitor closest to the source of the ripple current will operate hotter than the others, shortening its operating life; the others will not see this level of AC current. To ensure that they will evenly share the ripple current, ideally, any paralleled capacitors should be laid out in a radially-symmetric manner around the current source, typically a rectifier or power switch.

The PCB layout, if not done properly, can ruin a good paper design. It is important to follow these basic guidelines and monitor the layout every step of the process.

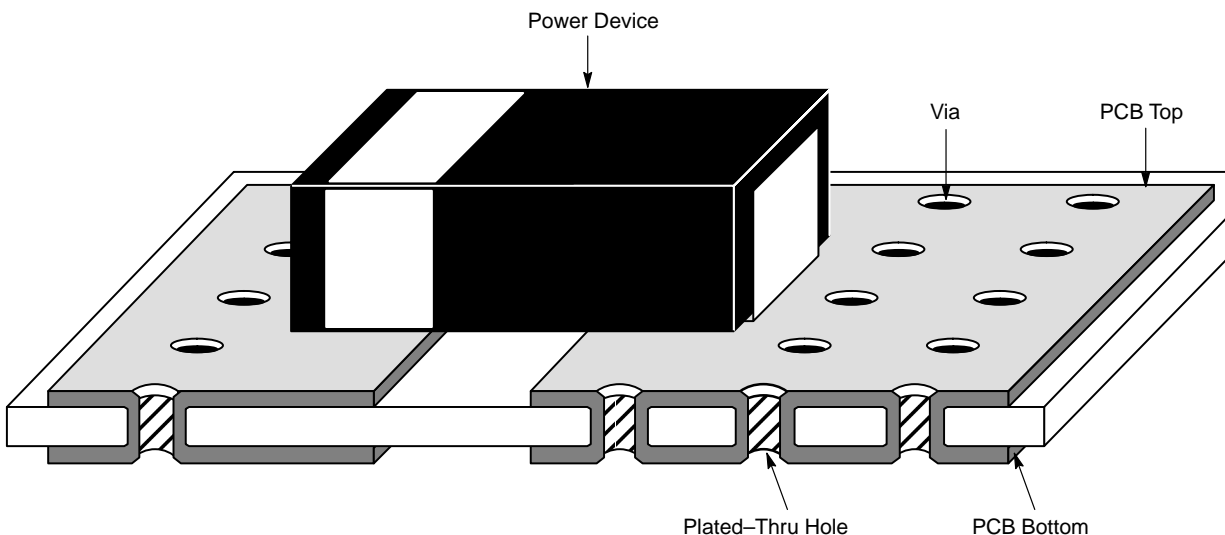


Figure 22. Method for Minimizing AC Capacitive Coupling and Enhancing Heatsinking



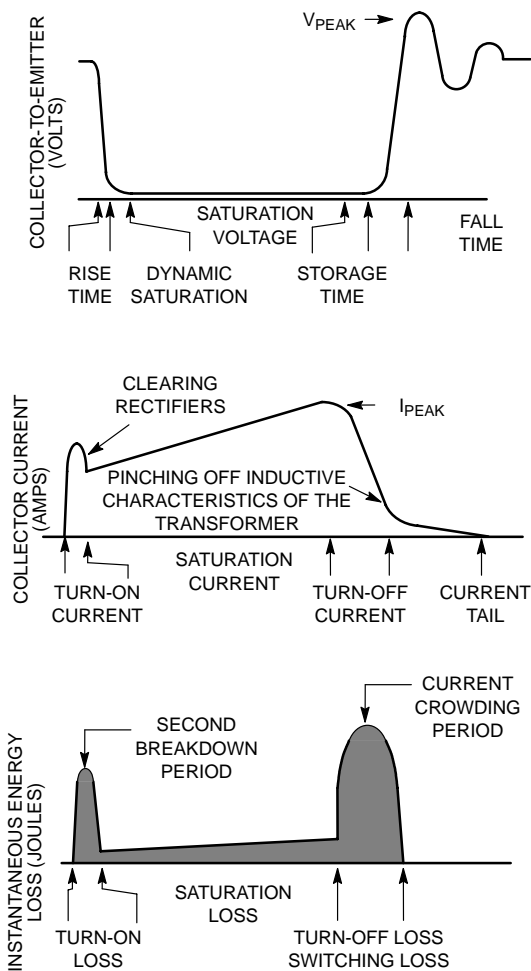
## Losses and Stresses in Switching Power Supplies

Much of the designer's time during a switching power supply design is spent in identifying and minimizing the losses within the supply. Most of the losses occur in the power components within the switching power supply. Some of these losses can also present stresses to the power semiconductors which may affect the long term reliability of the power supply, so knowing where they arise and how to control them is important.

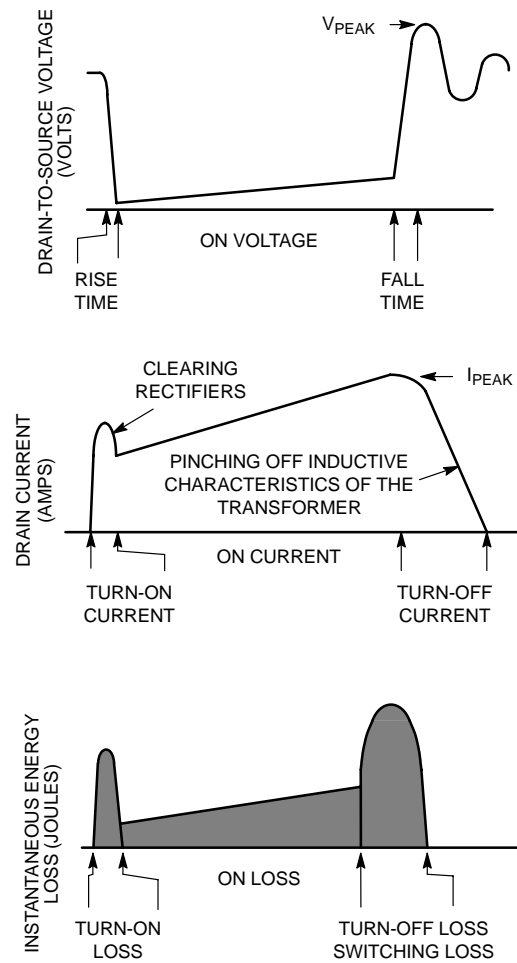
Whenever there is a simultaneous voltage drop across a component with a current flowing through, there is a loss. Some of these losses are controllable by modifying

the circuitry, and some are controlled by simply selecting a different part. Identifying the major sources for loss can be as easy as placing a finger on each of the components in search of heat, or measuring the currents and voltages associated with each power component using an oscilloscope, AC current probe and voltage probe.

Semiconductor losses fall into two categories: conduction losses and switching losses. The *conduction loss* is the product of the terminal voltage and current during the power device's on period. Examples of conduction losses are the saturation voltage of a bipolar power transistor and the "on" loss of a power MOSFET shown in Figure 23 and Figure 24 respectively.



**Figure 23. Stresses and Losses within a Bipolar Power Transistor**



**Figure 24. Stresses and Losses within a Power MOSFET**

The forward conduction loss of a rectifier is shown in Figure 25. During turn-off, the rectifier exhibits a *reverse recovery loss* where minority carriers trapped within the P-N junction must reverse their direction and exit the junction after a reverse voltage is applied. This results in what appears to be a current flowing in reverse through the diode with a high reverse terminal voltage.

The *switching loss* is the instantaneous product of the terminal voltage and current of a power device when it is transitioning between operating states (on-to-off and off-to-on). Here, voltages are transitional between full-on and cutoff states while simultaneously the current is transitional between full-on and cut-off states. This

creates a very large V-I product which is as significant as the conduction losses. Switching losses are also the major frequency dependent loss within every PWM switching power supply.

The loss-induced heat generation causes stress within the power component. This can be minimized by an effective thermal design. For bipolar power transistors, however, excessive switching losses can also provide a lethal stress to the transistor in the form of second breakdown and current crowding failures. Care should be taken in the careful analysis of each transistor's Forward Biased-Safe Operating Area (FBSOA) and Reverse Biased-Safe Operating Area (RBSOA) operation.

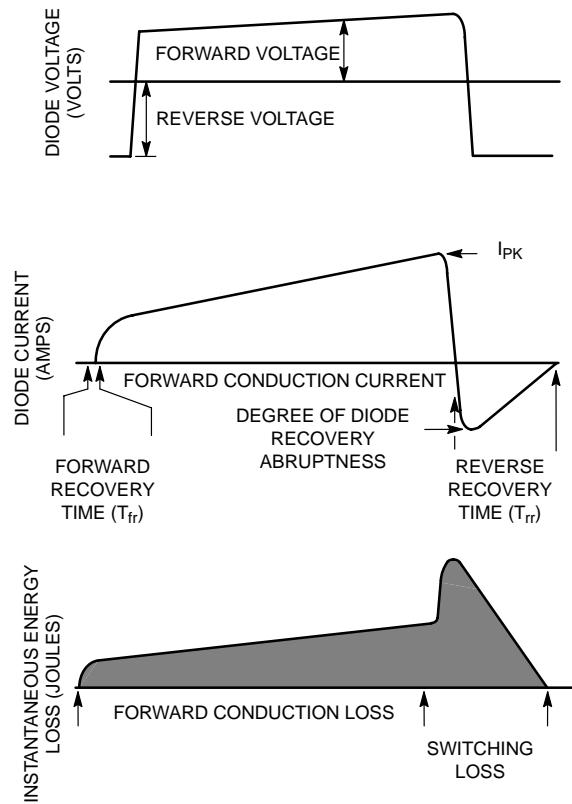


Figure 25. Stresses and Losses within Rectifiers

### Techniques to Improve Efficiency in Switching Power Supplies

The reduction of losses is important to the efficient operation of a switching power supply, and a great deal of time is spent during the design phase to minimize these losses. Some common techniques are described below.

#### The Synchronous Rectifier

As output voltages decrease, the losses due to the output rectifier become increasingly significant. For  $V_{out} = 3.3\text{ V}$ , a typical Schottky diode forward voltage of 0.4 V leads to a 12% loss of efficiency. Synchronous

rectification is a technique to reduce this conduction loss by using a switch in place of the diode. The synchronous rectifier switch is open when the power switch is closed, and closed when the power switch is open, and is typically a MOSFET inserted in place of the output rectifier. To prevent "crowbar" current that would flow if both switches were closed at the same time, the switching scheme must be break-before-make. Because of this, a diode is still required to conduct the initial current during the interval between the opening of the main switch and the closing of the synchronous rectifier switch. A Schottky rectifier with a current rating of 30 percent of

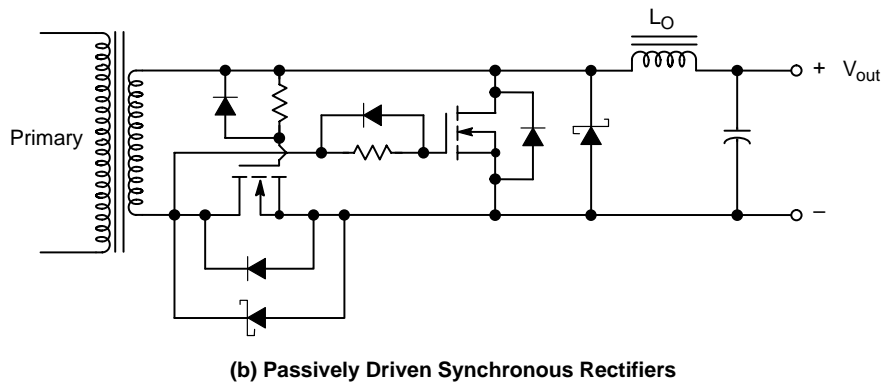
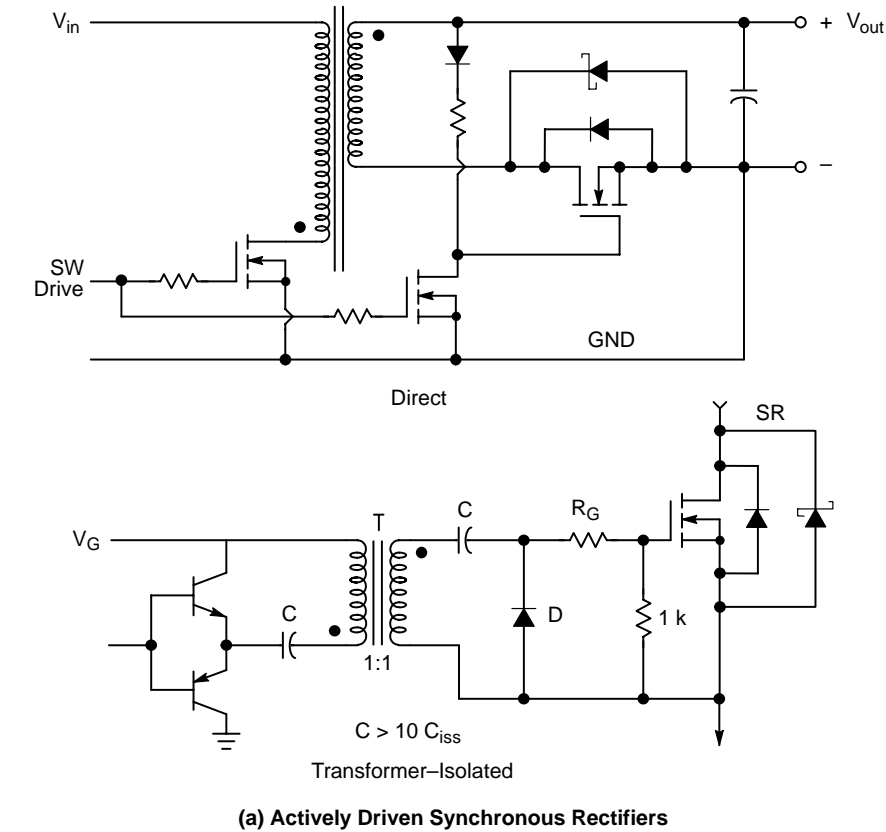
## SMPSRM

the MOSFET should be placed in parallel with the synchronous MOSFET. The MOSFET does contain a parasitic body diode that could conduct current, but it is lossy, slow to turn off, and can lower efficiency by 1% to 2%. The lower turn-on voltage of the Schottky prevents the parasitic diode from ever conducting and exhibiting its poor reverse recovery characteristic.

Using synchronous rectification, the conduction voltage can be reduced from 400 mV to 100 mV or less. An improvement of 1–5 percent can be expected for the

typical switching power supply.

The synchronous rectifier can be driven either actively, that is directly controlled from the control IC, or passively, driven from other signals within the power circuit. It is very important to provide a non-overlapping drive between the power switch(es) and the synchronous rectifier(s) to prevent any shoot-through currents. This dead time is usually between 50 to 100 ns. Some typical circuits can be seen in Figure 26.



**Figure 26. Synchronous Rectifier Circuits**

**Snubbers and Clamps**

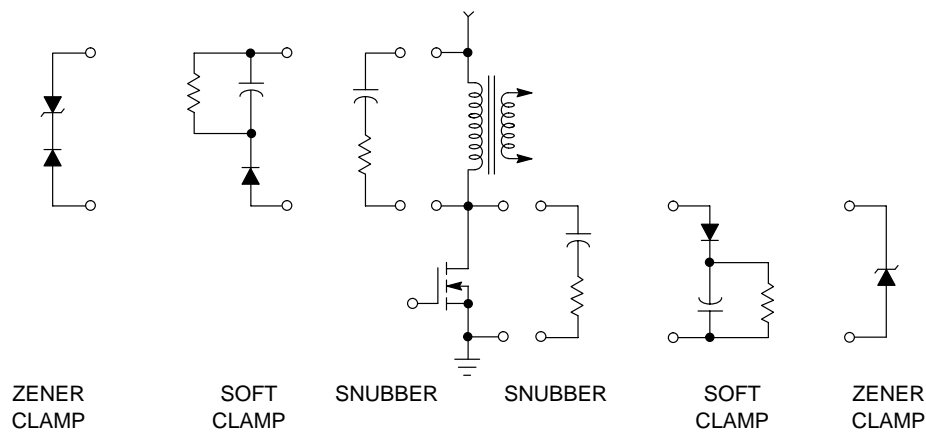
Snubbers and clamps are used for two very different purposes. When misapplied, the reliability of the semiconductors within the power supply is greatly jeopardized.

A snubber is used to reduce the level of a voltage spike and decrease the rate of change of a voltage waveform. This then reduces the amount of overlap of the voltage and current waveforms during a transition, thus reducing the switching loss. This has its benefits in the Safe Operating Area (SOA) of the semiconductors, and it reduces emissions by lowering the spectral content of any RFI.

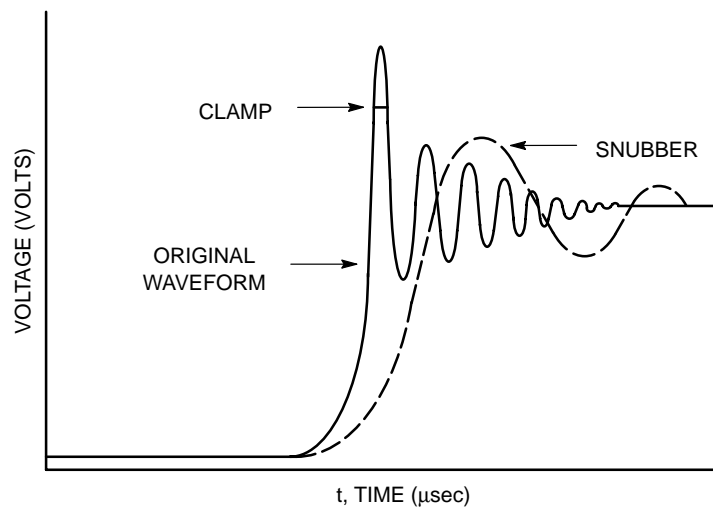
A clamp is used only for reducing the level of a voltage spike. It has no effect on the  $dV/dt$  of the transition.

Therefore it is not very useful for reducing RFI. It is useful for preventing components such as semiconductors and capacitors from entering avalanche breakdown.

Bipolar power transistors suffer from *current crowding* which is an instantaneous failure mode. If a voltage spike occurs during the turn-off voltage transition of greater than 75 percent of its VCEO rating, it may have too much current crowding stress. Here both the rate of change of the voltage and the peak voltage of the spike must be controlled. A snubber is needed to bring the transistor within its RBSOA (Reverse Bias Safe Operating Area) rating. Typical snubber and clamp circuits are shown in Figure 27. The effects that these have on a representative switching waveform are shown in Figure 28.



**Figure 27. Common Methods for Controlling Voltage Spikes and/or RFI**



**Figure 28. The Effects of a Snubber versus a Clamp**

## SMPSRM

### The Lossless Snubber

A lossless snubber is a snubber whose trapped energy is recovered by the power circuit. The lossless snubber is designed to absorb a fixed amount of energy from the transition of a switched AC voltage node. This energy is stored in a capacitor whose size dictates how much energy the snubber can absorb. A typical implementation of a lossless snubber can be seen in Figure 29.

The design for a lossless snubber varies from topology to topology and for each desired transition. Some adaptation may be necessary for each circuit. The important factors in the design of a lossless snubber are:

1. *The snubber must have initial conditions that allow it to operate during the desired transition and at the desired voltages.* Lossless snubbers should be emptied of their energy prior to the desired transition. The voltage to which it is reset dictates where the snubber will begin to operate. So if the snubber is reset to the input voltage, then it will act as a lossless clamp which will remove any spikes above the input voltage.

2. *When the lossless snubber is “reset,” the energy should be returned to the input capacitor or back into the output power path.* Study the supply carefully. Returning the energy to the input capacitor allows the supply to use the energy again on the next cycle. Returning the energy to ground in a boost-mode supply does not return the energy for reuse, but acts as a shunt current path around the power switch. Sometimes additional transformer windings are used.
3. *The reset current waveform should be band limited with a series inductor to prevent additional EMI from being generated.* Use of a 2 to 3 turn spiral PCB inductor is sufficient to greatly lower the di/dt of the energy exiting the lossless snubber.

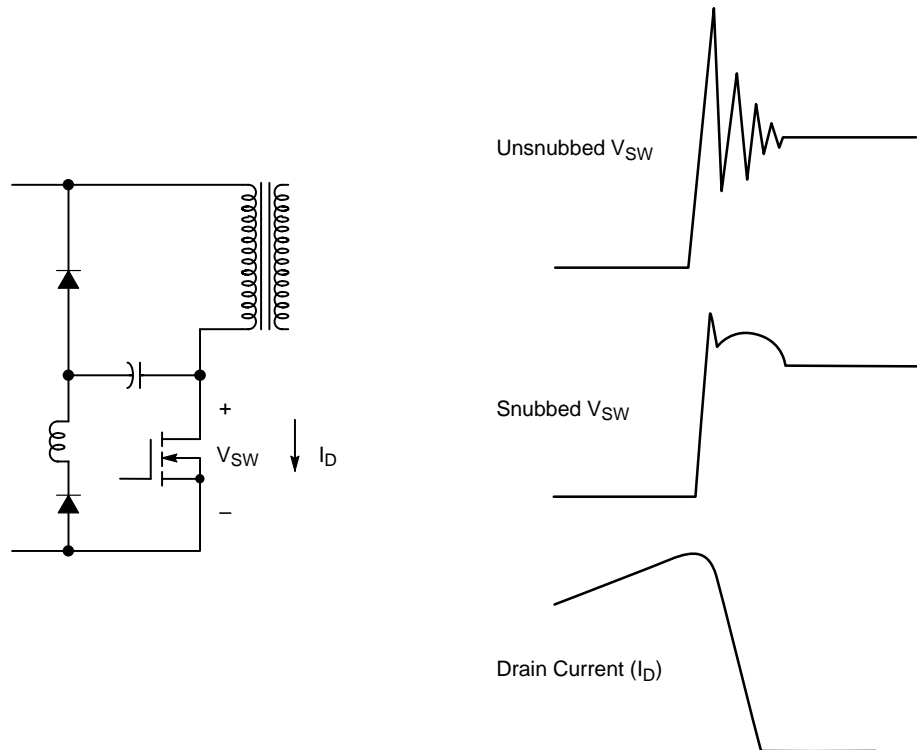


Figure 29. Lossless Snubber for a One Transistor Forward or Flyback Converter

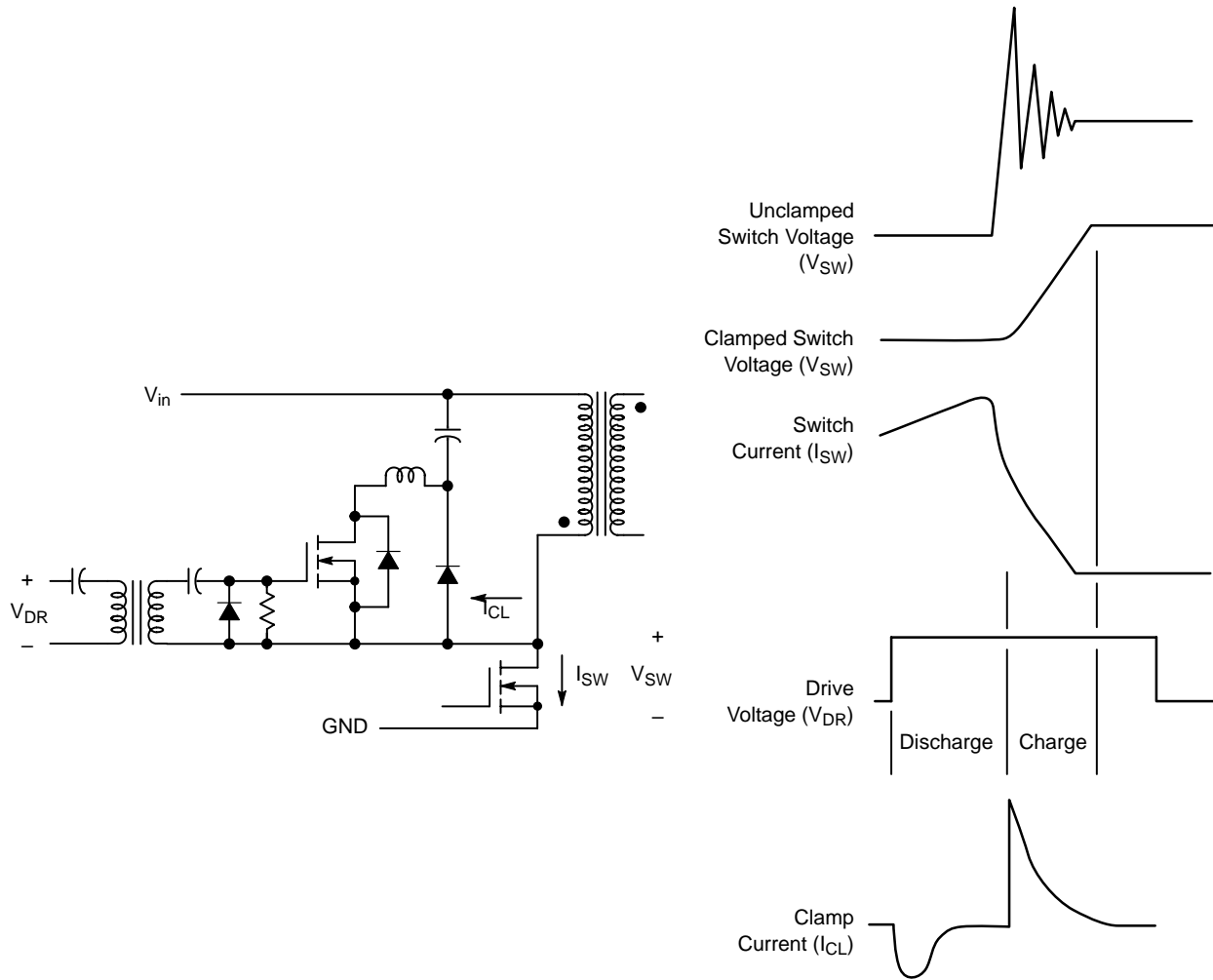
**The Active Clamp**

An active clamp is a gated MOSFET circuit that allows the controller IC to activate a clamp or a snubber circuit at a particular moment in a switching power supply's cycle of operation. An active clamp for a flyback converter is shown in Figure 30.

In Figure 30, the active clamp is reset (or emptied of its

stored energy) just prior to the turn-off transition. It is then disabled during the negative transition.

Obviously, the implementation of an active clamp is more expensive than other approaches, and is usually reserved for very compact power supplies where heat is a critical issue.



**Figure 30. An Active Clamp Used in a One Transistor Forward or a Flyback Converter**

## SMPSRM

### Quasi-Resonant Topologies

A quasi-resonant topology is designed to reduce or eliminate the frequency-dependent switching losses within the power switches and rectifiers. Switching losses account for about 40% of the total loss within a PWM power supply and are proportional to the switching frequency. Eliminating these losses allows the designer to increase the operating frequency of the switching power supply and so use smaller inductors and capacitors, reducing size and weight. In addition, RFI levels are reduced due to the controlled rate of change of current or voltage.

The downside to quasi-resonant designs is that they are more complex than non-resonant topologies due to parasitic RF effects that must be considered when

switching frequencies are in the 100's of kHz.

Schematically, quasi-resonant topologies are minor modifications of the standard PWM topologies. A resonant tank circuit is added to the power switch section to make either the current or the voltage "ring" through a half a sinusoid waveform. Since the sinusoid starts at zero and ends at zero, the product of the voltage and current at the starting and ending points is zero, thus has no switching loss.

There are two quasi-resonant methods: zero current switching (ZCS) or zero voltage switching (ZVS). ZCS is a fixed on-time, variable off-time method of control. ZCS starts from an initial condition where the power switch is off and no current is flowing through the resonant inductor. The ZCS quasi-resonant buck converter is shown in Figure 31.

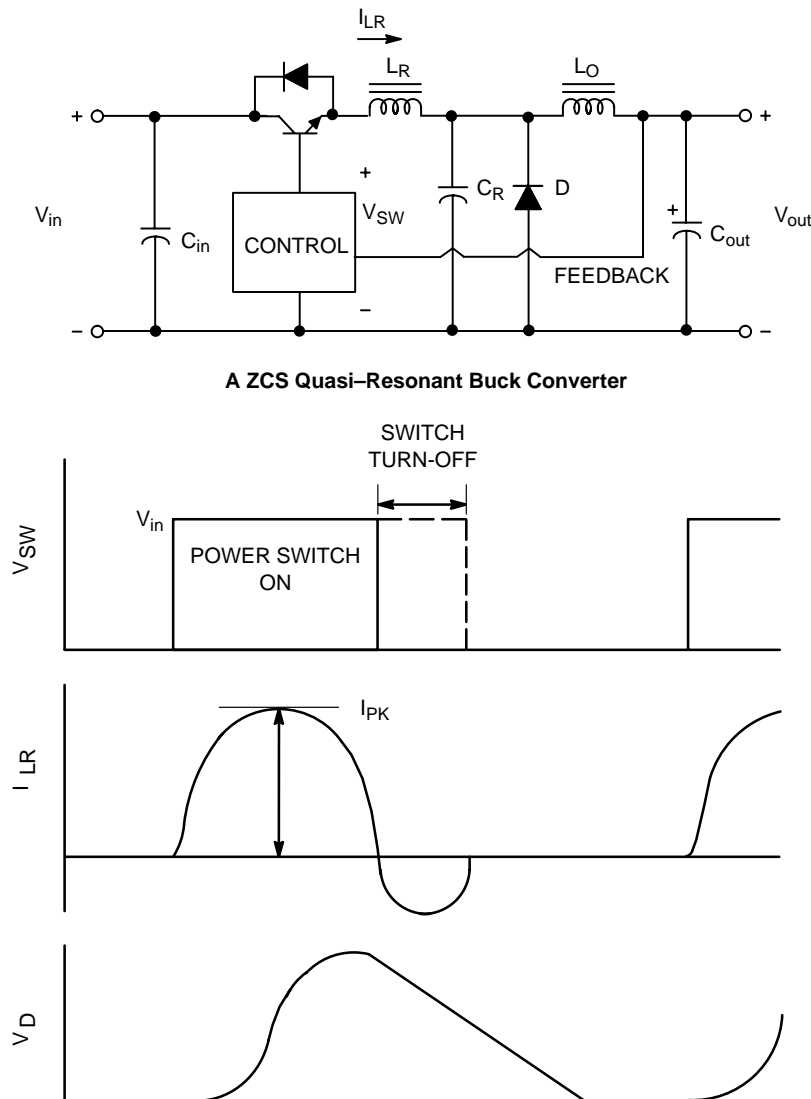


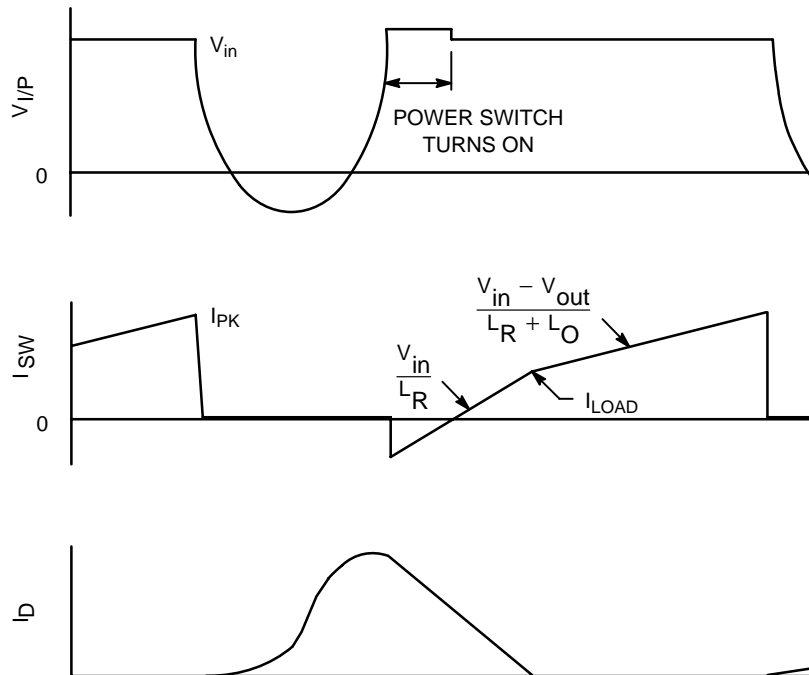
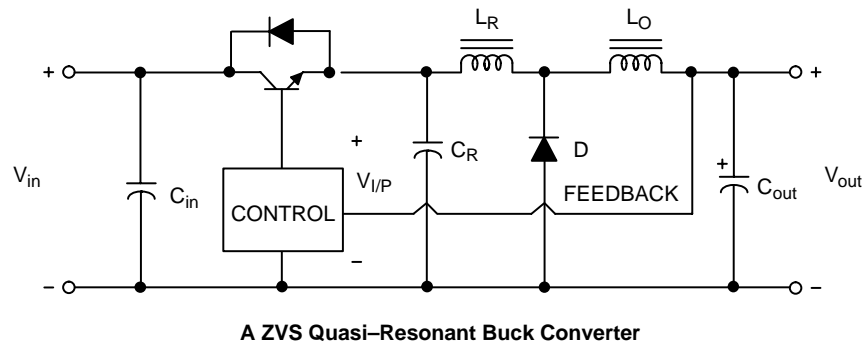
Figure 31. Schematic and Waveforms for a ZCS Quasi-Resonant Buck Converter

In this design, both the power switch and the catch diode operate in a zero current switching mode. Power is passed to the output during the resonant periods. So to increase the power delivered to the load, the frequency would increase, and vice versa for decreasing loads. In typical designs the frequency can change 10:1 over the ZCS supply's operating range.

The ZVS is a fixed off-time, variable on-time method control. Here the initial condition occurs when the power switch is on, and the familiar current ramp is flowing through the filter inductor. The ZVS quasi-resonant buck converter is shown in Figure 32. Here, to control the

power delivered to the load, the amount of “resonant off times” are varied. For light loads, the frequency is high. When the load is heavy, the frequency drops. In a typical ZVS power supply, the frequency typically varies 4:1 over the entire operating range of the supply.

There are other variations on the resonant theme that promote zero switching losses, such as full resonant PWM, full and half-bridge topologies for higher power and resonant transition topologies. For a more detailed treatment, see Chapter 4 in the “Power Supply Cookbook” (Bibliography reference 2).



**Figure 32. Schematic and Waveforms for a ZVS Quasi-Resonant Buck Converter**



### Power Factor Correction

Power Factor (PF) is defined as the ratio of real power to apparent power. In a typical AC power supply application where both the voltage and current are sinusoidal, the PF is given by the cosine of the phase angle between the input current and the input voltage and is a measure of how much of the current contributes to real power in the load. A power factor of unity indicates that 100% of the current is contributing to power in the load while a power factor of zero indicates that none of the current contributes to power in the load. Purely resistive loads have a power factor of unity; the current through them is directly proportional to the applied voltage.

The current in an ac line can be thought of as consisting of two components: real and imaginary. The real part results in power absorbed by the load while the imaginary part is power being reflected back into the source, such as is the case when current and voltage are of opposite polarity and their product, power, is negative.

It is important to have a power factor as close as possible to unity so that none of the delivered power is reflected back to the source. Reflected power is undesirable for three reasons:

1. The transmission lines or power cord will generate heat according to the total current being carried, the real part plus the reflected part. This causes problems for the electric utilities and has prompted various regulations

requiring all electrical equipment connected to a low voltage distribution system to minimize current harmonics and maximize power factor.

2. The reflected power not wasted in the resistance of the power cord may generate unnecessary heat in the source (the local step-down transformer), contributing to premature failure and constituting a fire hazard.
3. Since the ac mains are limited to a finite current by their circuit breakers, it is desirable to get the most power possible from the given current available. This can only happen when the power factor is close to or equal to unity.

The typical AC input rectification circuit is a diode bridge followed by a large input filter capacitor. During the time that the bridge diodes conduct, the AC line is driving an electrolytic capacitor, a nearly reactive load. This circuit will only draw current from the input lines when the input's voltage exceeds the voltage of the filter capacitor. This leads to very high currents near the peaks of the input AC voltage waveform as seen in Figure 33.

Since the conduction periods of the rectifiers are small, the peak value of the current can be 3–5 times the average input current needed by the equipment. A circuit breaker only senses average current, so it will not trip when the peak current becomes unsafe, as found in many office areas. This can present a fire hazard. In three-phase distribution systems, these current peaks sum onto the neutral line, not meant to carry this kind of current, which again presents a fire hazard.

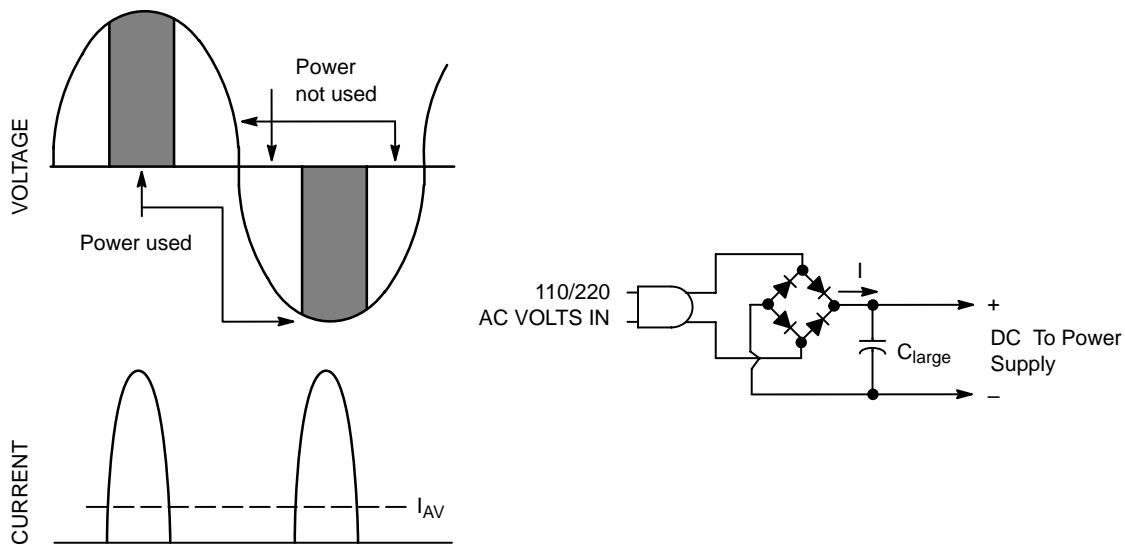


Figure 33. The Waveforms of a Capacitive Input Filter

A Power Factor Correction (PFC) circuit is a switching power converter, essentially a boost converter with a very wide input range, that precisely controls its input current on an instantaneous basis to match the waveshape and phase of the input voltage. This represents a zero degrees or 100 percent power factor and mimics a purely resistive load. The amplitude of the input current waveform is varied over longer time frames to maintain a constant voltage at the converter's output filter capacitor. This mimics a resistor which slowly changes value to absorb the correct amount of power to meet the demand of the load. Short term energy excesses and deficits caused by sudden changes in the load are supplemented by a "bulk energy storage capacitor", the boost converter's output filter device. The PFC input filter capacitor is reduced to a few microfarads, thus placing a half-wave haversine waveshape into the PFC converter.

The PFC boost converter can operate down to about 30 V before there is insufficient voltage to draw any more significant power from its input. The converter then can begin again when the input haversine reaches 30 V on the next half-wave haversine. This greatly increases the conduction angle of the input rectifiers. The drop-out region of the PFC converter is then filtered (smoothed) by the input EMI filter.

A PFC circuit not only ensures that no power is reflected back to the source, it also eliminates the high current pulses associated with conventional rectifier-filter input circuits. Because heat lost in the transmission line and adjacent circuits is proportional to the square of the current in the line, short strong current

pulses generate more heat than a purely resistive load of the same power. The active power factor correction circuit is placed just following the AC rectifier bridge. An example can be seen in Figure 34.

Depending upon how much power is drawn by the unit, there is a choice of three different common control modes. All of the schematics for the power sections are the same, but the value of the PFC inductor and the control method are different. For input currents of less than 150 watts, a *discontinuous-mode* control scheme is typically used, in which the PFC core is completely emptied prior to the next power switch conduction cycle. For powers between 150 and 250 watts, the *critical conduction mode* is recommended. This is a method of control where the control IC senses just when the PFC core is emptied of its energy and the next power switch conduction cycle is immediately begun; this eliminates any dead time exhibited in the discontinuous-mode of control. For an input power greater than 250 watts, the *continuous-mode* of control is recommended. Here the peak currents can be lowered by the use of a larger inductor, but a troublesome reverse recovery characteristic of the output rectifier is encountered, which can add an additional 20-40 percent in losses to the PFC circuit.

Many countries cooperate in the coordination of their power factor requirements. The most appropriate document is IEC61000-3-2, which encompasses the performance of generalized electronic products. There are more detailed specifications for particular products made for special markets.

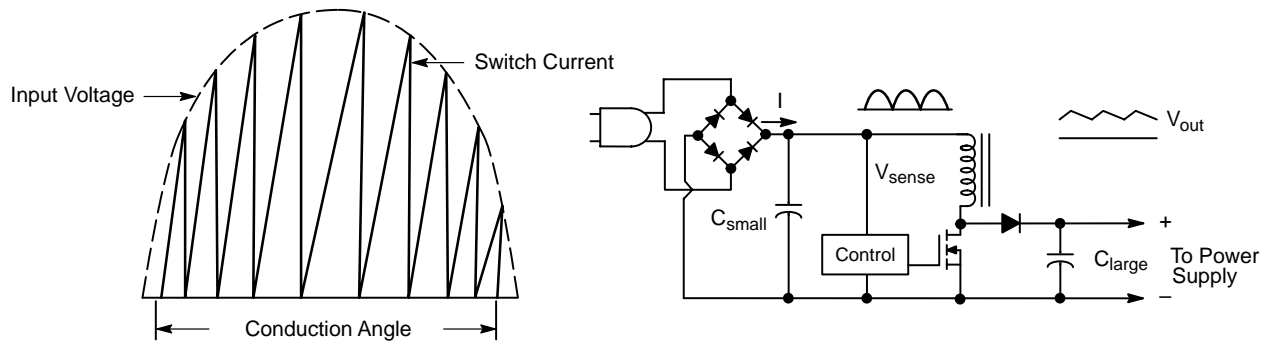


Figure 34. Power Factor Correction Circuit

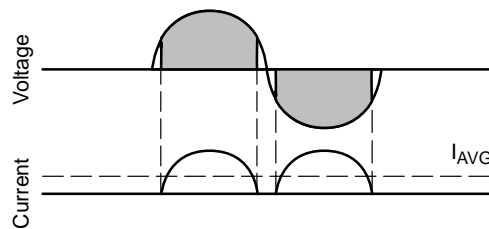


Figure 35. Waveform of Corrected Input

## **Bibliography**

1. Ben–Yaakov Sam, Gregory Ivensky, “Passive Lossless Snubbers for High Frequency PWM Converters,” Seminar 12, APEC 99.
2. Brown, Marty, *Power Supply Cookbook*, Butterworth–Heinemann, 1994, 2001.
3. Brown, Marty, “Laying Out PC Boards for Embedded Switching Supplies,” *Electronic Design*, Dec. 1999.
4. Martin, Robert F., “Harmonic Currents,” *Compliance Engineering – 1999 Annual Resources Guide*, Cannon Communications, LLC, pp. 103–107.
5. ON Semiconductor, *Rectifier Applications Handbook*, HB214/D, Rev. 2, Nov. 2001.

## SWITCHMODE Power Supply Examples

This section provides both initial and detailed information to simplify the selection and design of a variety of SWITCHMODE power supplies. The ICs for Switching Power Supplies figure identifies control, reference voltage, output protection and switching regulator ICs for various topologies.

	Page
<i>ICs for Switching Power Supplies</i> .....	36
Integrated circuits identified for various sections of a switching power supply.	
<i>Suggested Components for Specific Applications</i> .....	37
A list of suggested control ICs, power transistors and rectifiers for SWITCHMODE power supplies by application.	
• CRT Display System .....	38
• AC/DC Power Supply for CRT Displays .....	39
• AC/DC Power Supply for Storage, Imaging & Entertainment .....	39
• DC–DC Conversion .....	40
• Typical PC Forward–Mode SMPS .....	41
<i>Real SMPS Applications</i>	
80 W Power Factor Correction Controller .....	42
Compact Power Factor Correction .....	43
Monitor Pulsed–Mode SMPS .....	44
70 W Wide Mains TV SMPS .....	46
100 W Wide Mains TV SMPS with 1.3 W Stand–by .....	48
Low–Cost Off–line IGBT Battery Charger .....	50
110 W Output Flyback SMPS .....	51
Efficient Safety Circuit for Electronic Ballast .....	53
AC–DC Battery Charger – Constant Current with Voltage Limit .....	55

Some of these circuits may have a more complete application note, spice model information or even an evaluation board available. Consult ON Semiconductor’s website (<http://onsemi.com>) or local sales office for more information.

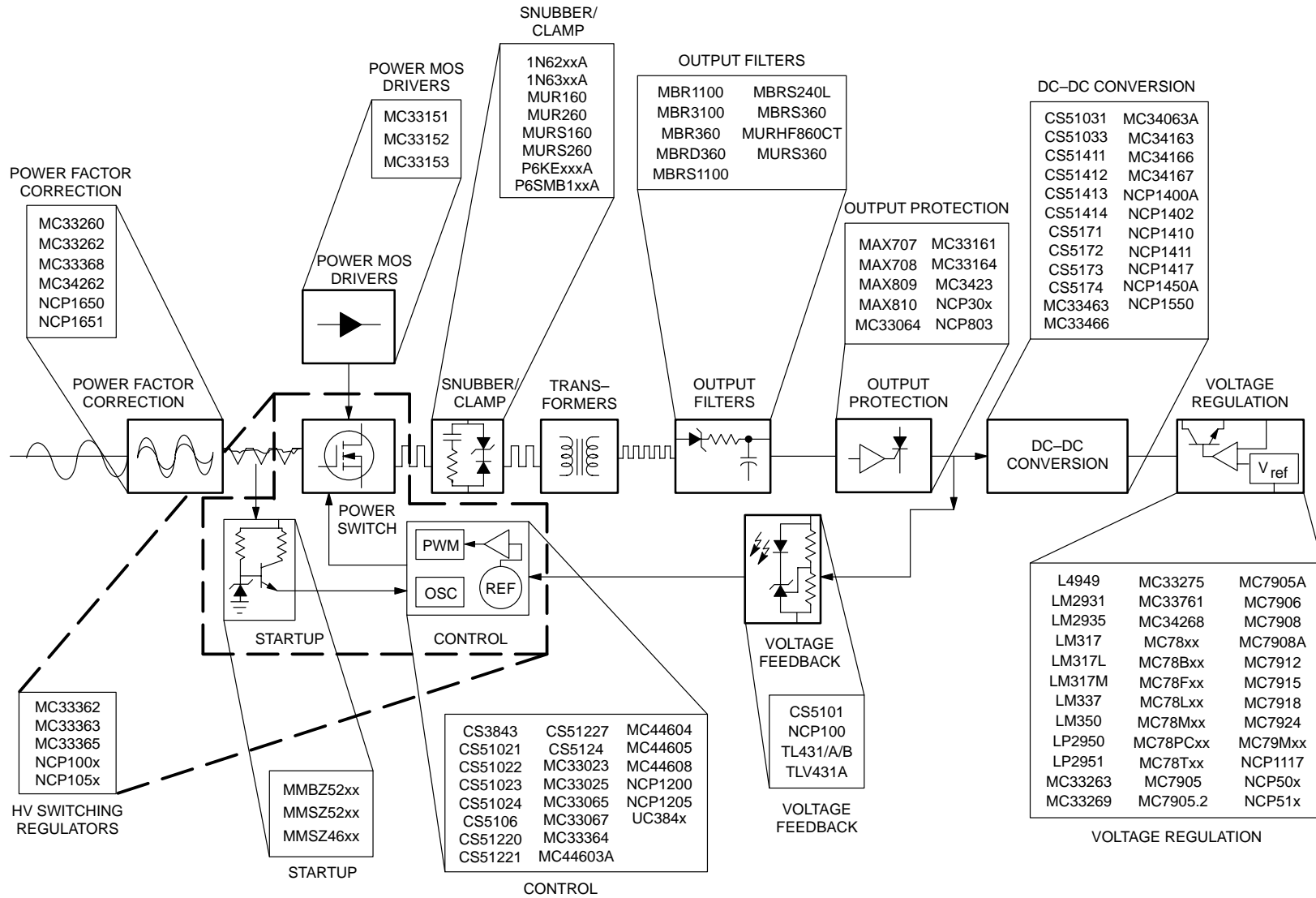


Figure 30. Integrated Circuits for Switching Power Supplies

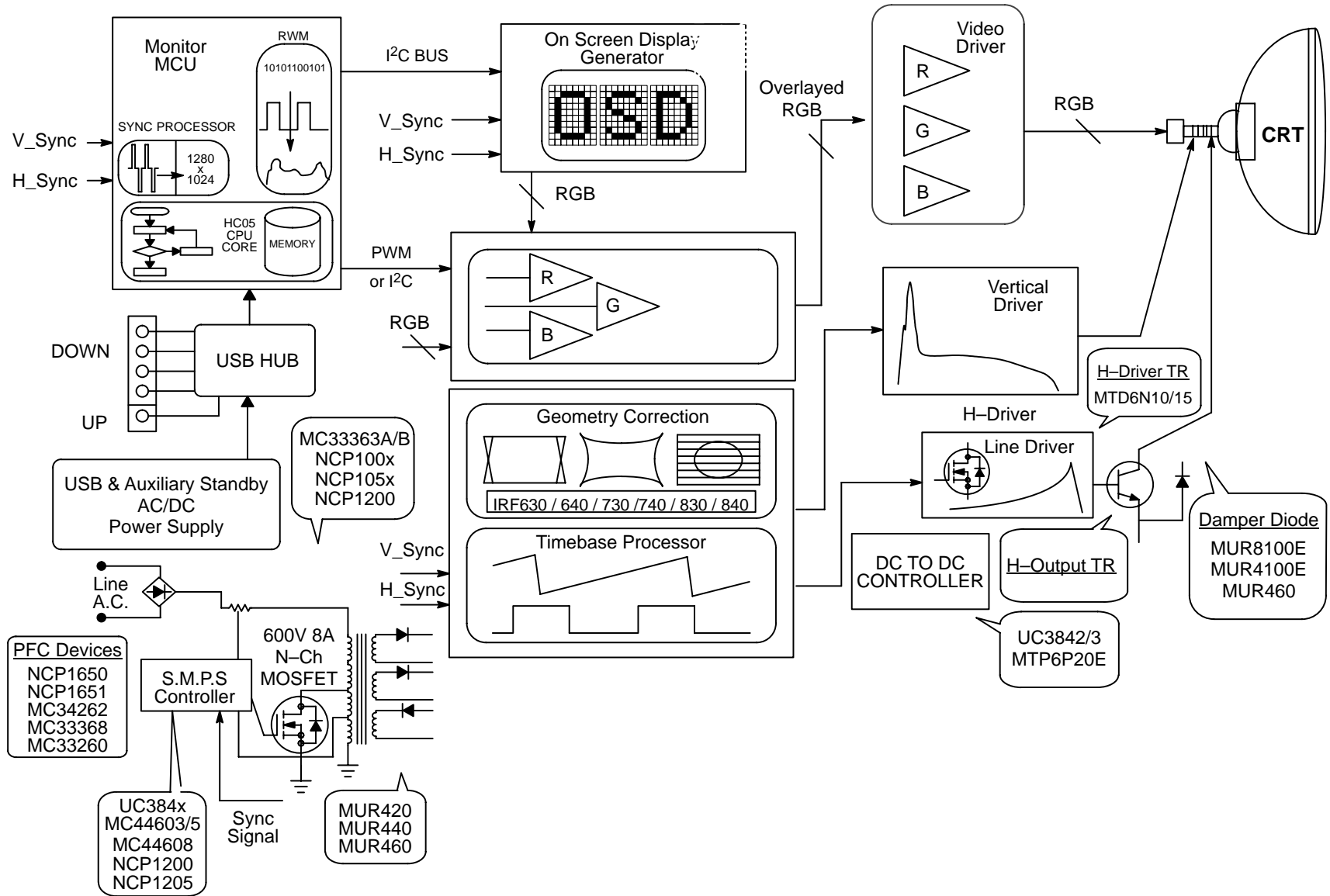
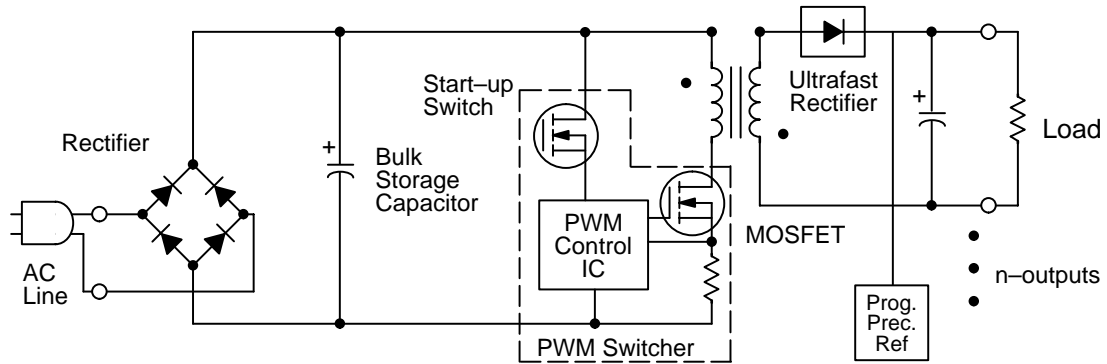


Figure 31. 15" Monitor Power Supplies

**SMPSRM**



**Figure 38. AC/DC Power Supply for CRT Displays**

**Table 1.**

Part #	Description	Key Parameters	Samples/Prod.
MC33262	PFC Control IC	Critical Conduction PFC Controller	Now/Now
MC33368	PFC Control IC	Critical Conduction PFC Controller + Internal Start-up	Now/Now
MC33260	PFC Control IC	Low System Cost, PFC with Synchronization Capability, Follower Boost Mode, or Normal Mode	Now/Now
MC33365	PWM Control IC	Fixed Frequency Controller + 700 V Start-up, 1 A Power Switch	Now/Now
MC33364	PWM Control IC	Variable Frequency Controller + 700 V Start-up Switch	Now/Now
MC44603A/604	PWM Control IC	GreenLine, Sync. Facility with Low Standby Mode	Now/Now
MC44605	PWM Control IC	GreenLine, Sync. Facility, Current-mode	Now/Now
MC44608	PWM Control IC	GreenLine, Fixed Frequency (40 kHz, 75 kHz and 100 kHz options), Controller + Internal Start-up, 8-pin	Now/Now
MSR860	Ultrasoft Rectifier	600 V, 8 A, trr = 55 ns, Ir max = 1 uA	Now/Now
MUR440	Ultrafast Rectifier	400 V, 4 A, trr = 50 ns, Ir max = 10 uA	Now/Now
MRA4006T3	Fast Recovery Rectifier	800 V, 1 A, Vf = 1.1 V @ 1.0 A	Now/Now
MR856	Fast Recovery Rectifier	600 V, 3 A, Vf = 1.25 V @ 3.0 A	Now/Now
NCP1200	PWM Current-Mode Controller	110 mA Source/Sink, O/P Protection, 40/60/110 kHz	Now/Now
NCP1205	Single-Ended PWM Controller	Quasi-resonant Operation, 250 mA Source/Sink, 8-36 V Operation	Now/Now
UC3842/3/4/5	High Performance Current-Mode Controllers	500 kHz Freq., Totem Pole O/P, Cycle-by-Cycle Current Limiting, UV Lockout	Now/Now

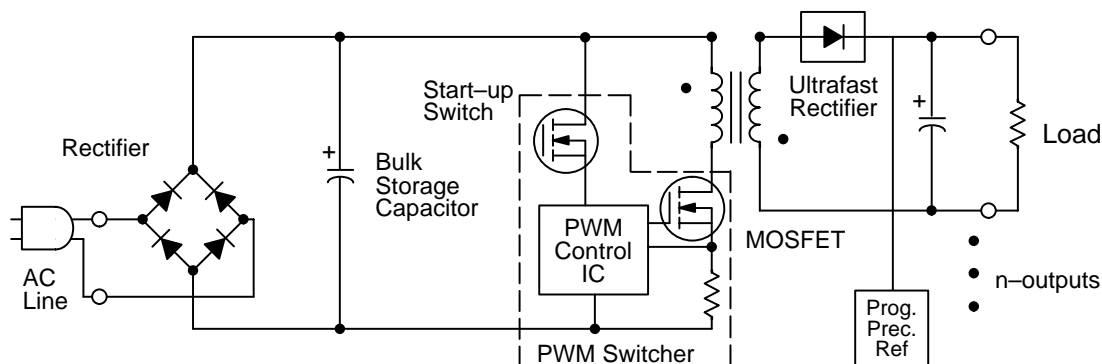


Figure 39. AC/DC Power Supply for Storage, Imaging & Entertainment

Table 2.

Part #	Description	Key Parameters	Samples/Prod.
MC33363A/B/65	PWM Control IC	Controller + 700 V Start-up & Power Switch, < 15 W	Now/Now
MC33364	PWM Control IC	Critical Conduction Mode, SMPS Controller	Now/Now
TL431B	Program Precision Reference	0.4% Tolerance, Prog. Output up to 36 V, Temperature Compensated	Now/Now
MSRD620CT	Ultrasoft Rectifier	200 V, 6 A, trr = 55 ns, Ir max = 1 uA	Now/Now
MR856	Fast Recovery Rectifier	600 V, 3 A, Vf = 1.25 V @ 3.0 A	Now/Now
NCP1200	PWM Current-Mode Controller	110 mA Source/Sink, O/P Protection, 40/60/110 kHz	Now/Now
NCP1205	Single-Ended PWM Controller	Quasi-resonant Operation, 250 mA Source/Sink, 8-36 V Operation	Now/Now
UC3842/3/4/5	High Performance Current-Mode Controllers	500 kHz Freq., Totem Pole O/P, Cycle-by-Cycle Current Limiting, UV Lockout	Now/Now



## SMPSRM

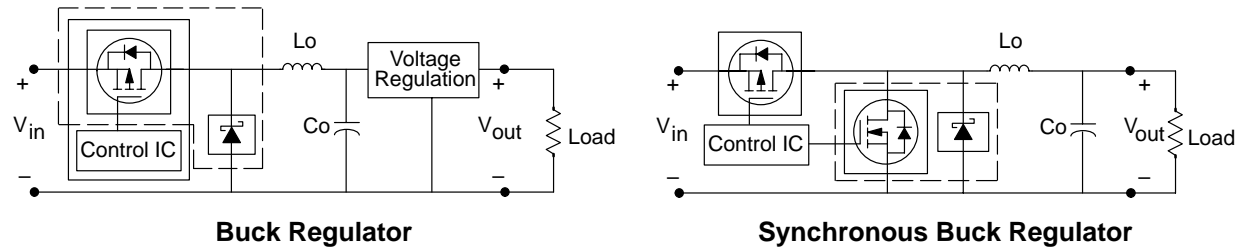


Figure 40. DC – DC Conversion

Table 3.

Part #	Description	Key Parameters	Samples/Prod.
MC33263	Low Noise, Low Dropout Regulator IC	150 mA; 8 Outputs 2.8 V – 5 V; SOT 23L 6 Lead Package	Now/Now
MC33269	Medium Dropout Regulator IC	0.8 A; 3.3; 5, 12 V out; 1 V diff; 1% Tolerance	Now/Now
MC33275/375	Low Dropout Regulator	300 mA; 2.5, 3, 3.3, 5 V out	Now/Now
LP2950/51	Low Dropout, Fixed Voltage IC	0.1 A; 3, 3.3, 5 V out; 0.38 V diff; 0.5% Tolerance	Now/Now
MC78PC	CMOS LDO Linear Voltage Regulator	$I_{out} = 150$ mA, Available in 2.8 V, 3 V, 3.3 V, 5 V; SOT 23 – 5 Leads	Now/Now
MC33470	Synchronous Buck Regulator IC	Digital Controlled; $V_{cc} = 7$ V; Fast Response	Now/Now
NTMSD2P102LR2	P–Ch FET w/Schottky in SO–8	20 V, 2 A, 160 m $\Omega$ FET/1 A, $V_f = 0.46$ V Schottky	Now/Now
NTMSD3P102R2	P–Ch FET w/Schottky in SO–8	20 V, 3 A, 160 m $\Omega$ FET/1 A, $V_f = 0.46$ V Schottky	Now/Now
MMDFS6N303R2	N–Ch FET w/Schottky in SO–8	30 V, 6 A, 35 m $\Omega$ FET/3 A, $V_f = 0.42$ V Schottky	Now/Now
NTMSD3P303R2	P–Ch FET w/Schottky in SO–8	30 V, 3 A, 100 m $\Omega$ FET/3 A, $V_f = 0.42$ V Schottky	Now/Now
MBRM140T3	1A Schottky in POWERMITE® Package	40 V, 1 A, $V_f = 0.43$ @ 1 A; $I_r = 0.4$ mA @ 40 V	Now/Now
MBRA130LT3	1A Schottky in SMA Package	40 V, 1 A, $V_f = 0.395$ @ 1 A; $I_r = 1$ mA @ 40 V	Now/Now
MBRS2040LT3	2A Schottky in SMB Package	40 V, 2 A, $V_f = 0.43$ @ 2 A; $I_r = 0.8$ mA @ 40 V	Now/Now
MMSF3300	Single N–Ch MOSFET in SO–8	30 V, 11.5 A <sup>(1)</sup> , 12.5 m $\Omega$ @ 10 V	Now/Now
NTD4302	Single N–Ch MOSFET in DPAK	30 V, 18.3 A <sup>(1)</sup> , 10 m $\Omega$ @ 10 V	Now/Now
NTTS2P03R2	Single P–Ch MOSFET in Micro8™ Package	30 V, 2.7 A, 90 m $\Omega$ @ 10 V	Now/Now
MGSF3454X/V	Single N–Ch MOSFET in TSOP–6	30 V, 4.2 A, 65 m $\Omega$ @ 10 V	Now/Now
NTGS3441T1	Single P–Ch MOSFET in TSOP–6	20 V, 3.3 A, 100 m $\Omega$ @ 4.5 V	Now/Now
NCP1500	Dual Mode PWM Linear Buck Converter	Prog. O/P Voltage 1.0, 1.3, 1.5, 1.8 V	Now/Now
NCP1570	Low Voltage Synchronous Buck Converter	UV Lockout, 200 kHz Osc. Freq., 200 ns Response	Now/Now
NCP1571	Low Voltage Synchronous Buck Converter	UV Lockout, 200 kHz Osc. Freq., 200 ns Response	Now/Now
CS5422	Dual Synchronous Buck Converter	150 kHz–600 kHz Prog. Freq., UV Lockout, 150 ns Transient Response	Now/Now

(1) Continuous at  $T_A = 25^\circ$  C, Mounted on 1" square FR–4 or G10,  $V_{GS} = 10$  V  $t \leq 10$  seconds

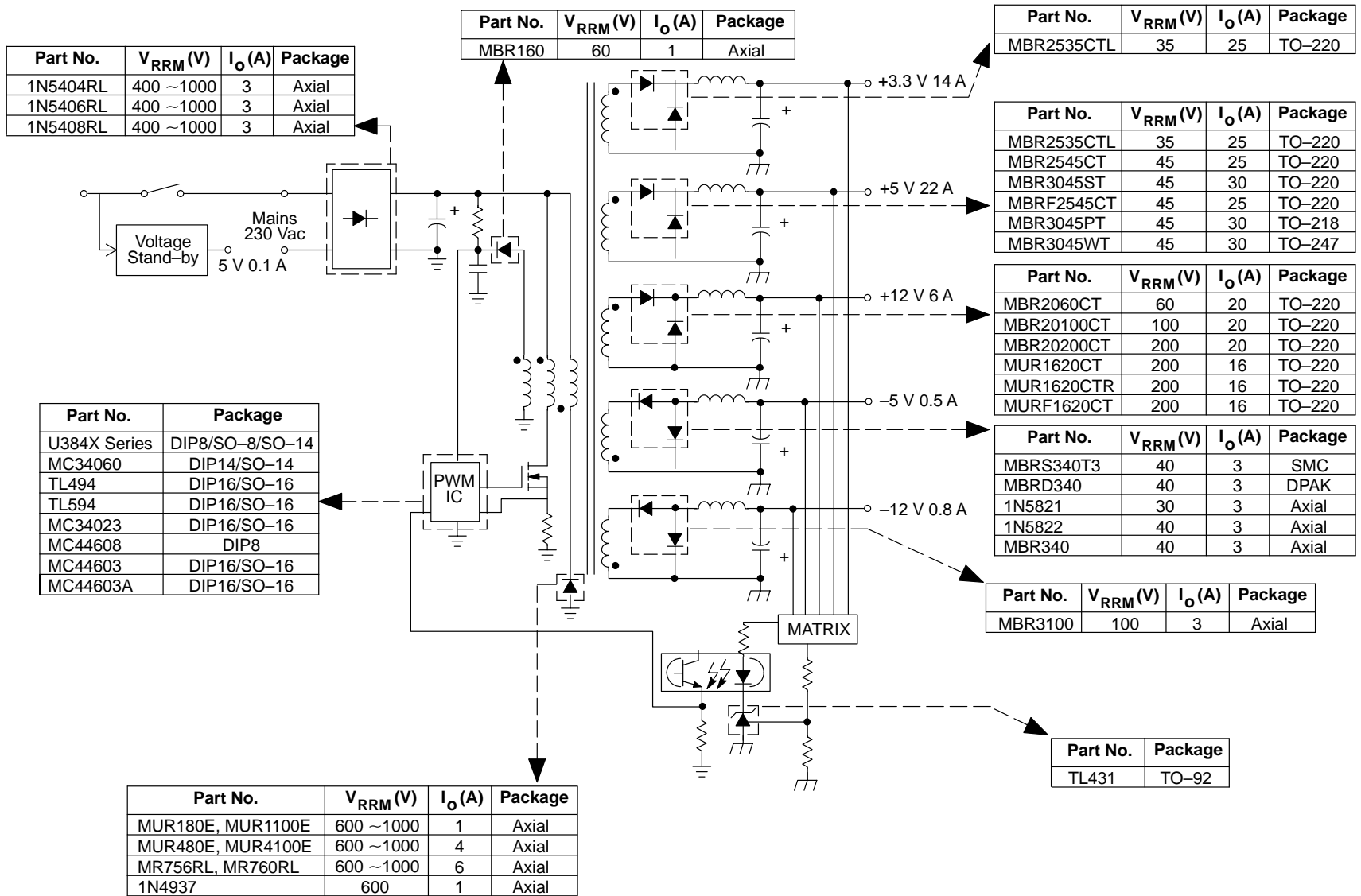


Figure 35. Typical 200 W ATX Forward Mode SMPS

### Application: 80 W Power Factor Controller

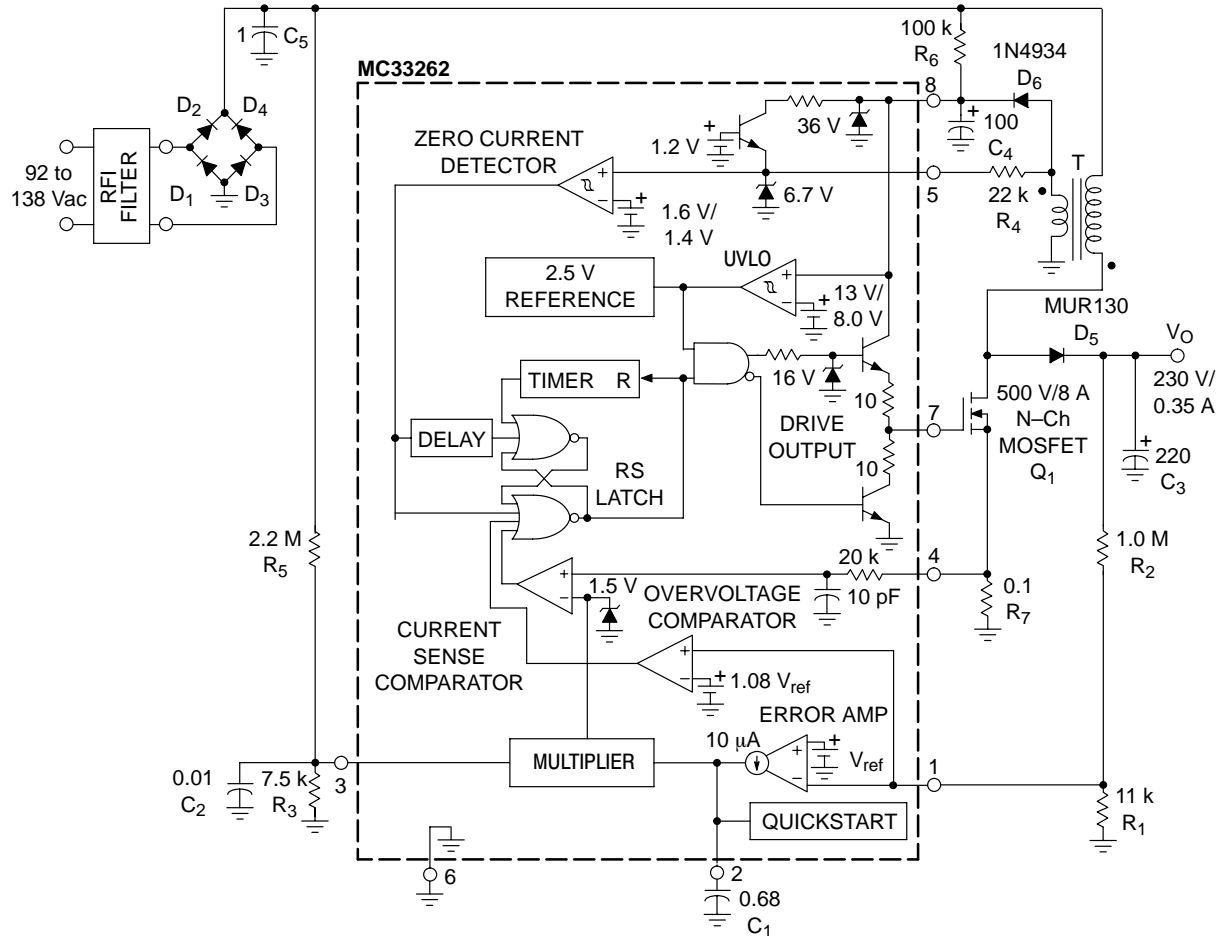


Figure 42. 80 W Power Factor Controller

**Features:**

Reduced part count, low-cost solution.

**ON Semiconductor Advantages:**

Complete semiconductor solution based around highly integrated MC33262.

**Devices:**

Part Number	Description
MC33262	Power Factor Controller
MUR130	Axial Lead Ultrafast Recovery Rectifier (300 V)
Transformer	Coilcraft N2881-A Primary: 62 turns of #22 AWG Secondary: 5 turns of #22 AWG Core: Coilcraft PT2510 Gap: 0.072" total for a primary inductance (Lp) of 320 μH

## Application: Compact Power Factor Correction

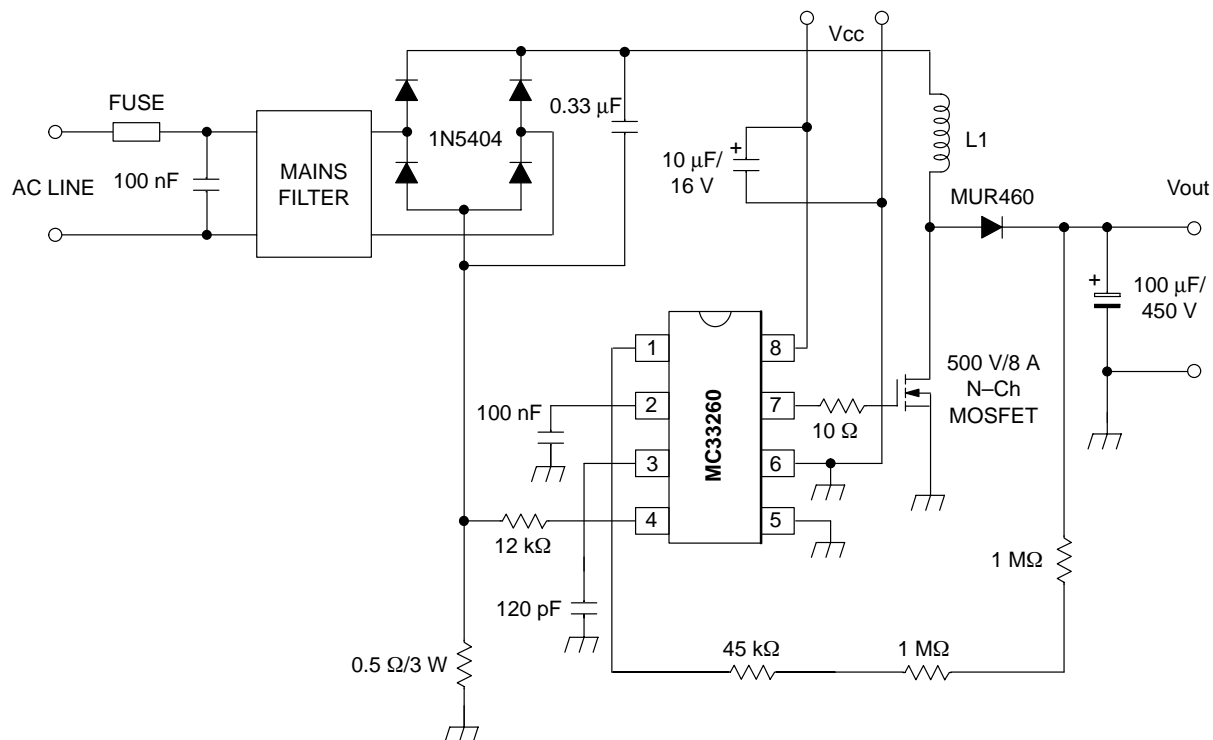


Figure 43. Compact Power Factor Correction

*Features :*

- Low-cost system solution for boost mode follower.
- Meets IEC1000-3-2 standard.
- Critical conduction, voltage mode.
- Follower boost mode for system cost reduction – smaller inductor and MOSFET can be used.
- Inrush current detection.
- Protection against overcurrent, overvoltage and undervoltage.

*ON Semiconductor advantages:*

- Very low component count.
- No Auxiliary winding required.
- High reliability.
- Complete semiconductor solution.
- Significant system cost reduction.

*Devices:*

Part Number	Description
MC33260	Power Factor Controller
MUR460	Ultrafast Recovery Rectifier (600 V)
1N5404	General Purpose Rectifier (400 V)

# Application: Monitor Pulsed-Mode SMPS

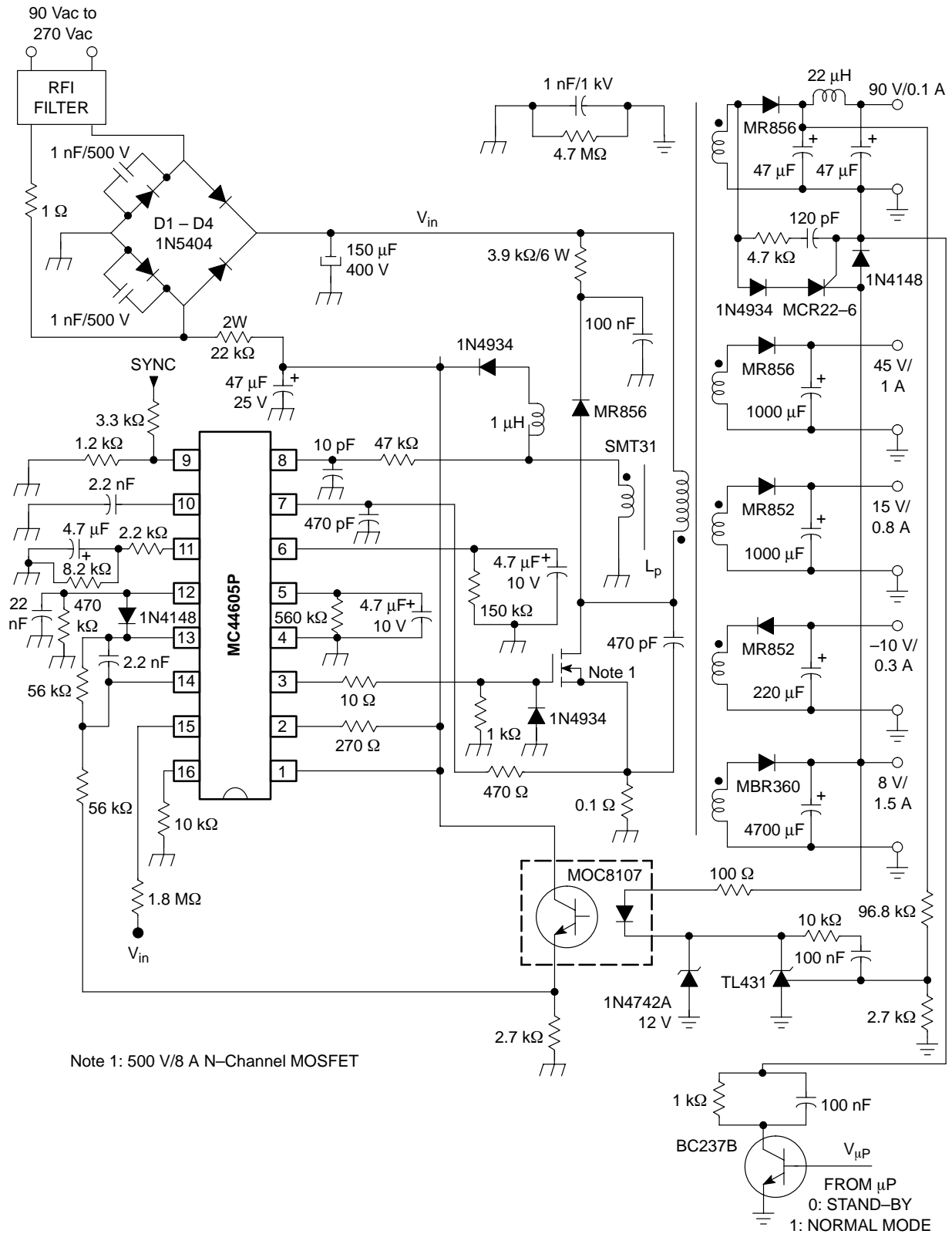


Figure 44. Monitor Pulsed-Mode SMPS

*Features:*

Off power consumption: 40 mA drawn from the 8 V output in Burst mode.

Vac (110 V) → about 1 watt

Vac (240 V) → about 3 watts

Efficiency (pout = 85 watts)

Around 77% @ Vac (110 V)

Around 80% @ Vac (240 V)

Maximum Power limitation.

Over-temperature detection.

Winding short circuit detection.

*ON Semiconductor Advantages:*

Designed around high performance current mode controller.

Built-in latched disabling mode.

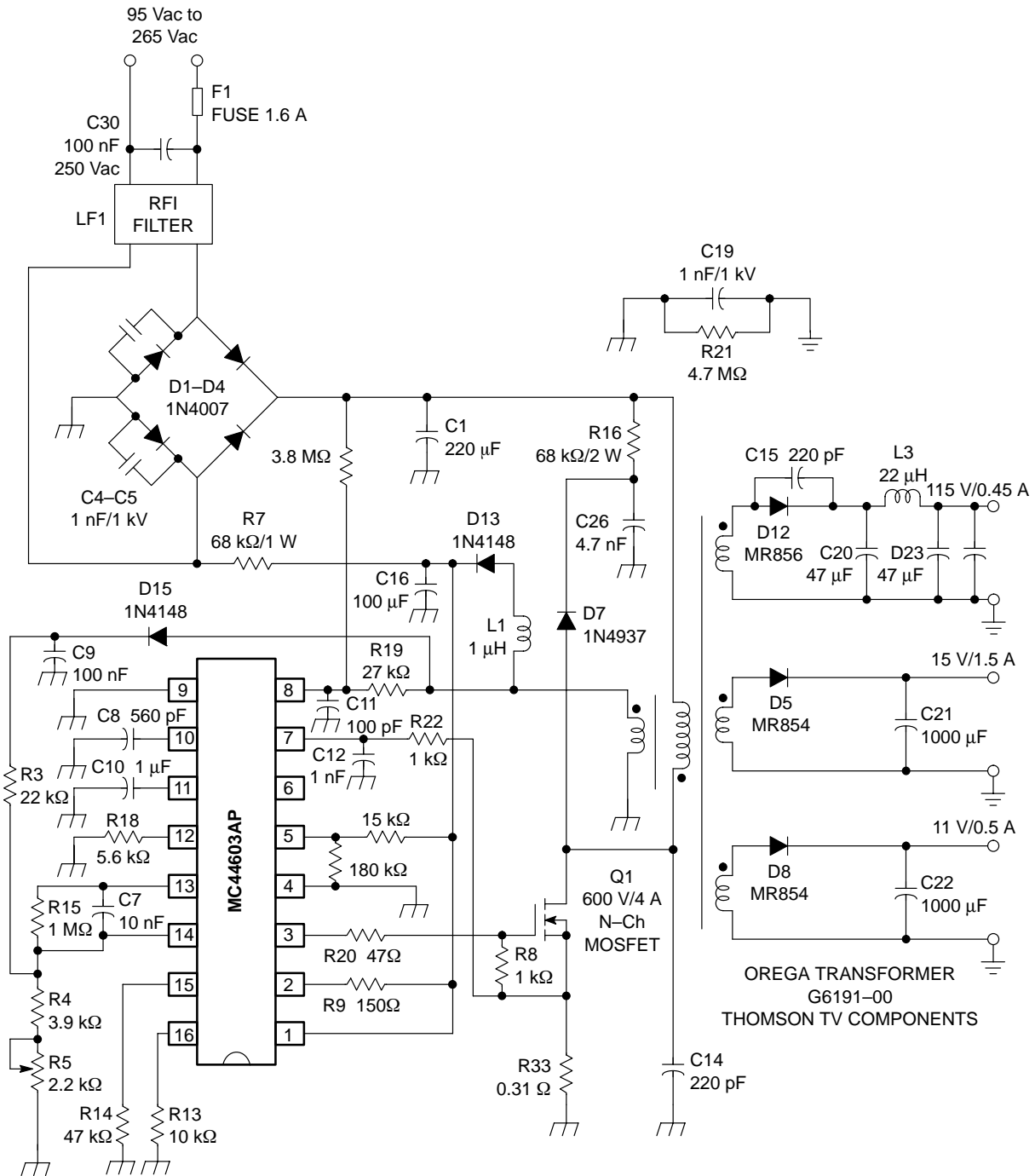
Complete semiconductor solution.

*Devices:*

Part Number	Description
MC44605P	High Safety Latched Mode GreenLine™ Controller For (Multi) Synchronized Applications
TL431	Programmable Precision Reference
MR856	Fast Recovery Rectifier (600 V)
MR852	Fast Recovery Rectifier (200 V)
MBR360	Axial Lead Schottky Rectifier (60 V)
BC237B	NPN Bipolar Transistor
1N5404	General-Purpose Rectifier (400 V)
1N4742A	Zener Regulator (12 V, 1 W)
Transformer	G6351-00 (SMT31M) from Thomson Orega Primary inductance = 207 μH Area = 190 nH/turns <sup>2</sup> Primary turns = 33 Turns (90 V) = 31

**SMPSRM**

**Application: 70 W Wide Mains TV SMPS**



**Figure 45. 70 W Wide Mains TV SMPS**

*Features:*

70 W output power from 95 to 265 Vac.

## Efficiency

@ 230 Vac = 86%

@ 110 Vac = 84%

Load regulation (115 Vac) =  $\pm 0.8$  V.

Cross regulation (115 Vac) =  $\pm 0.2$  V.

Frequency 20 kHz fully stable.

*ON Semiconductor Advantages:*

DIP16 or SO16 packaging options for controller.

Meets IEC emi radiation standards.

A narrow supply voltage design (80 W) is also available.

*Devices:*

Part Number	Description
MC44603AP	Enhanced Mixed Frequency Mode GreenLine™ PWM Controller
MR856	Fast Recovery Rectifier (600 V)
MR854	Fast Recovery Rectifier (400 V)
1N4007	General Purpose Rectifier (1000 V)
1N4937	General Purpose Rectifier (600 V)
Transformer	Thomson Orega SMT18



SMPSRM

Application: Wide Mains 100 W TV SMPS with 1.3 W TV Stand-by

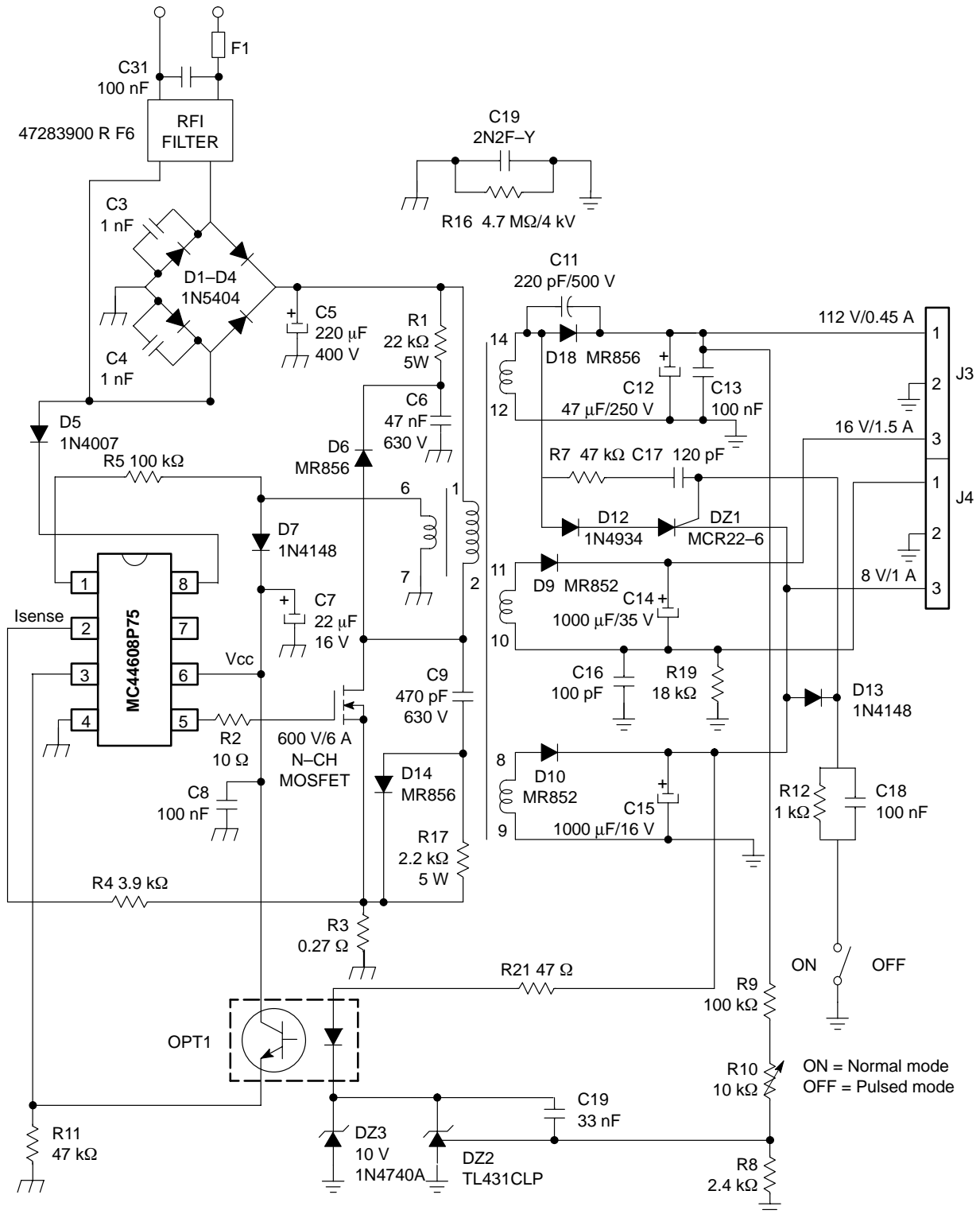


Figure 46. Wide Mains 100 W TV SMPS with Secondary Reconfiguration for 1.3 W TV Stand-by

*Features:*

- Off power consumption: 300mW drawn from the 8V output in pulsed mode.
- $P_{in} = 1.3W$  independent of the mains.
- Efficiency: 83%
- Maximum power limitation.
- Over-temperature detection.
- Demagnetization detection.
- Protection against open loop.

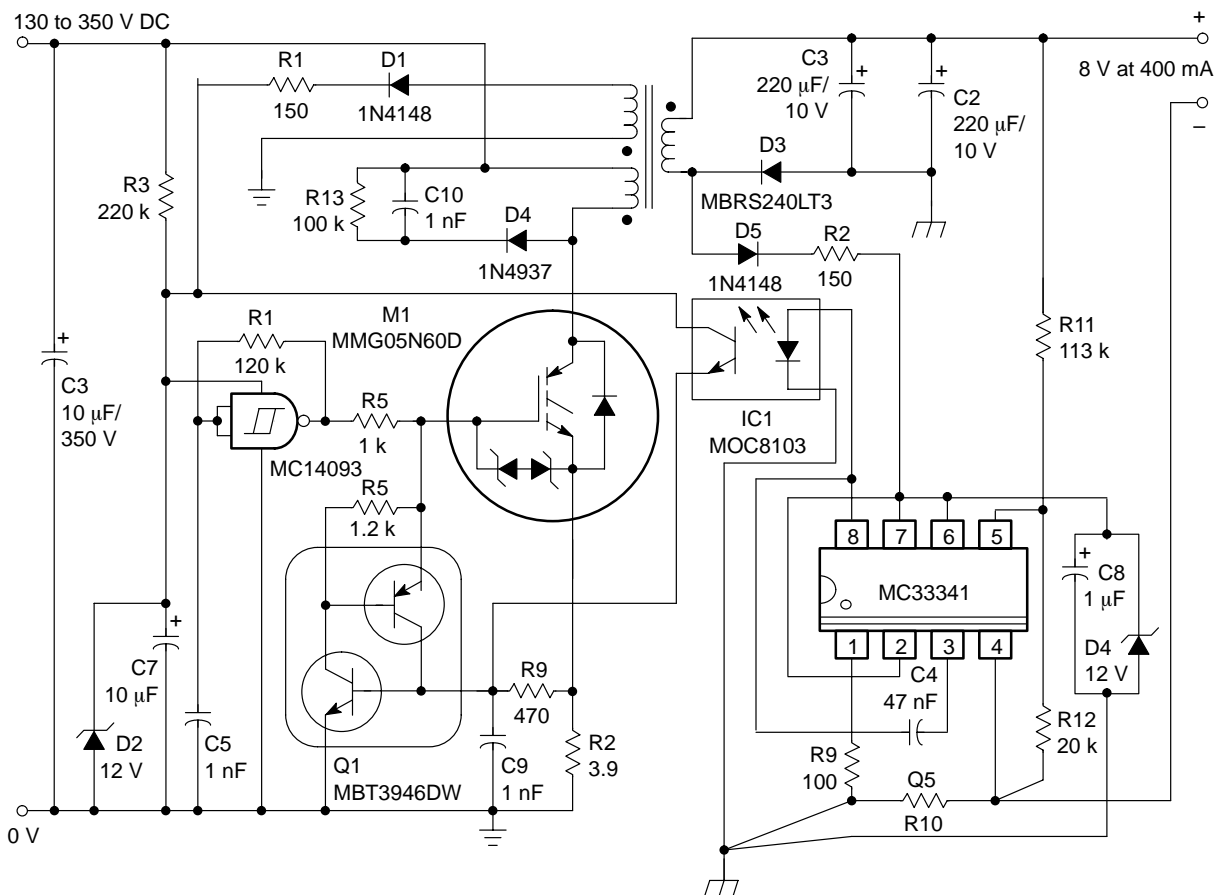
*ON Semiconductor Advantages:*

- Very low component count controller.
- Fail safe open feedback loop.
- Programmable pulsed-mode power transfer for efficient system stand-by mode.
- Stand-by losses independent of the mains value.
- Complete semiconductor solution.

*Devices:*

Part Number	Description
MC44608P75	GreenLine™ Very High Voltage PWM Controller
TL431	Programmable Precision Reference
MR856	Fast Recovery Rectifier (600 V)
MR852	Fast Recovery Rectifier (200 V)
1N5404	General Purpose Rectifier (400 V)
1N4740A	Zener Regulator (10 V, 1 W)
Transformer	SMT19 40346-29 (9 slots coil former) Primary inductance: 181 mH N <sub>primary</sub> : 40 turns N 112 V: 40 turns N 16 V: 6 turns N 8 V: 3 turns

# Application: Low-Cost Offline IGBT Battery Charger



**Figure 47. Low-Cost Offline IGBT Battery Charger**

**Features:**

- Universal ac input.
- 3 Watt capability for charging portable equipment.
- Light weight.
- Space saving surface mount design.

**ON Semiconductor Advantages:**

- Special-process IGBT (Normal IGBTs will not function properly in this application).
- Off the shelf components.
- SPICE model available for MC33341.

**Devices:**

Part Number	Description
MMG05N60D	Insulated Gate Bipolar Transistor in SOT-223 Package
MC33341	Power Supply Battery Charger Regulator Control Circuit
MBT3946DW	Dual General Purpose (Bipolar) Transistors
MBRS240LT3	Surface Mount Schottky Power Rectifier
MC14093	Quad 2-Input "NAND" Schmitt Trigger
1N4937	General-Purpose Rectifier (600 V)

### Application: 110 W Output Flyback SMPS

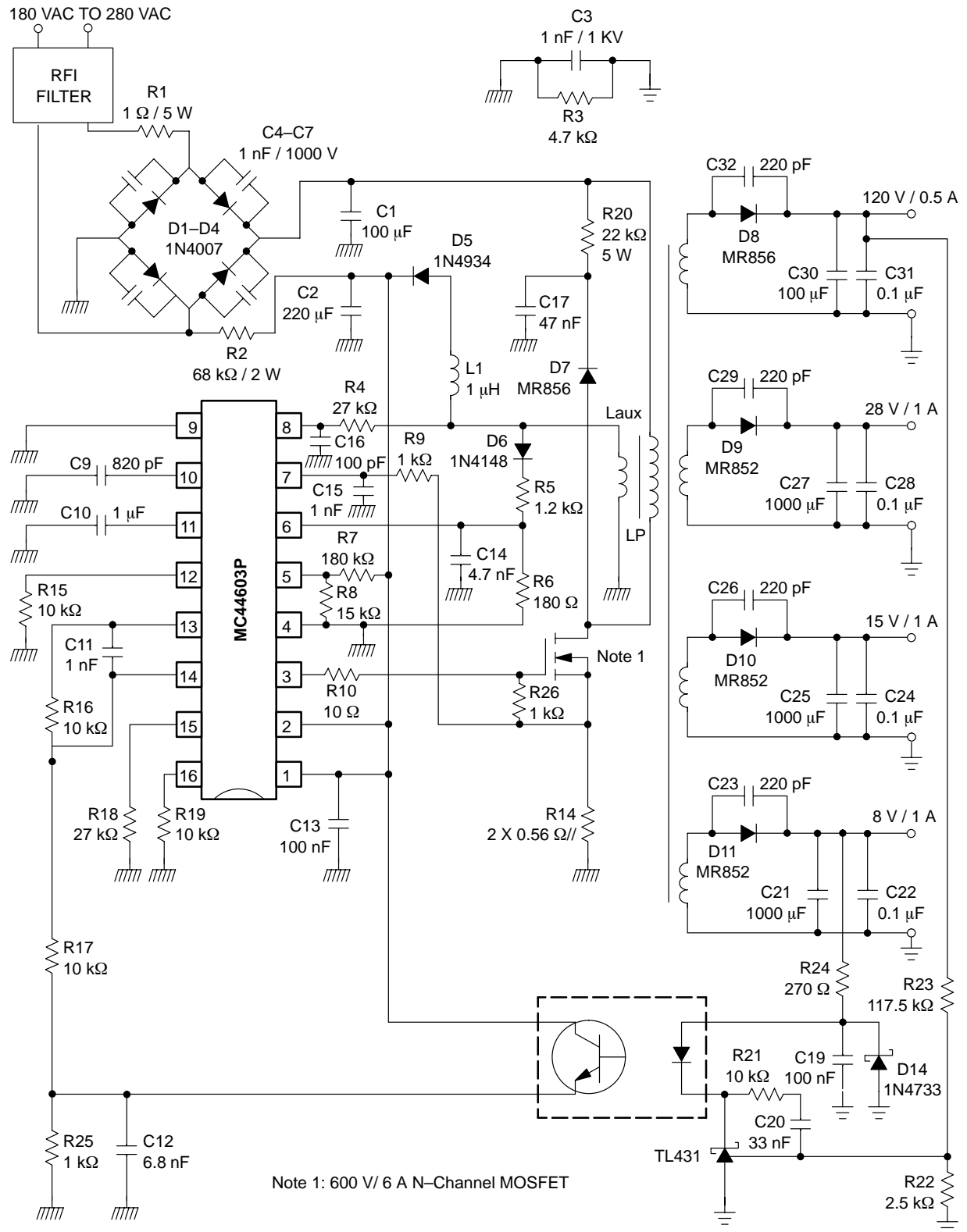


Figure 48. 110 W Output Flyback SMPS

## SMPSRM

### *Features:*

- Off-line operation from 180 V to 280 Vac mains.
- Fixed frequency and stand-by mode.
- Automatically changes operating mode based on load requirements.
- Precise limiting of maximum power in fixed frequency mode.

### *ON Semiconductor Advantages:*

- Built-in protection circuitry for current limitation, overvoltage detection, foldback, demagnetization and softstart.
- Reduced frequency in stand-by mode.

### *Devices:*

Part Number	Description
MC44603P	Enhanced Mixed Frequency Mode GreenLine™ PWM Controller
MR856	Fast Recovery Rectifier (600 V)
MR852	Fast Recovery Rectifier (200 V)
TL431	Programmable Precision Reference
1N4733A	Zener Voltage Regulator Diode (5.1 V)
1N4007	General Purpose Rectifier (1000 V)

# Application: Efficient Safety Circuit for Electronic Ballast

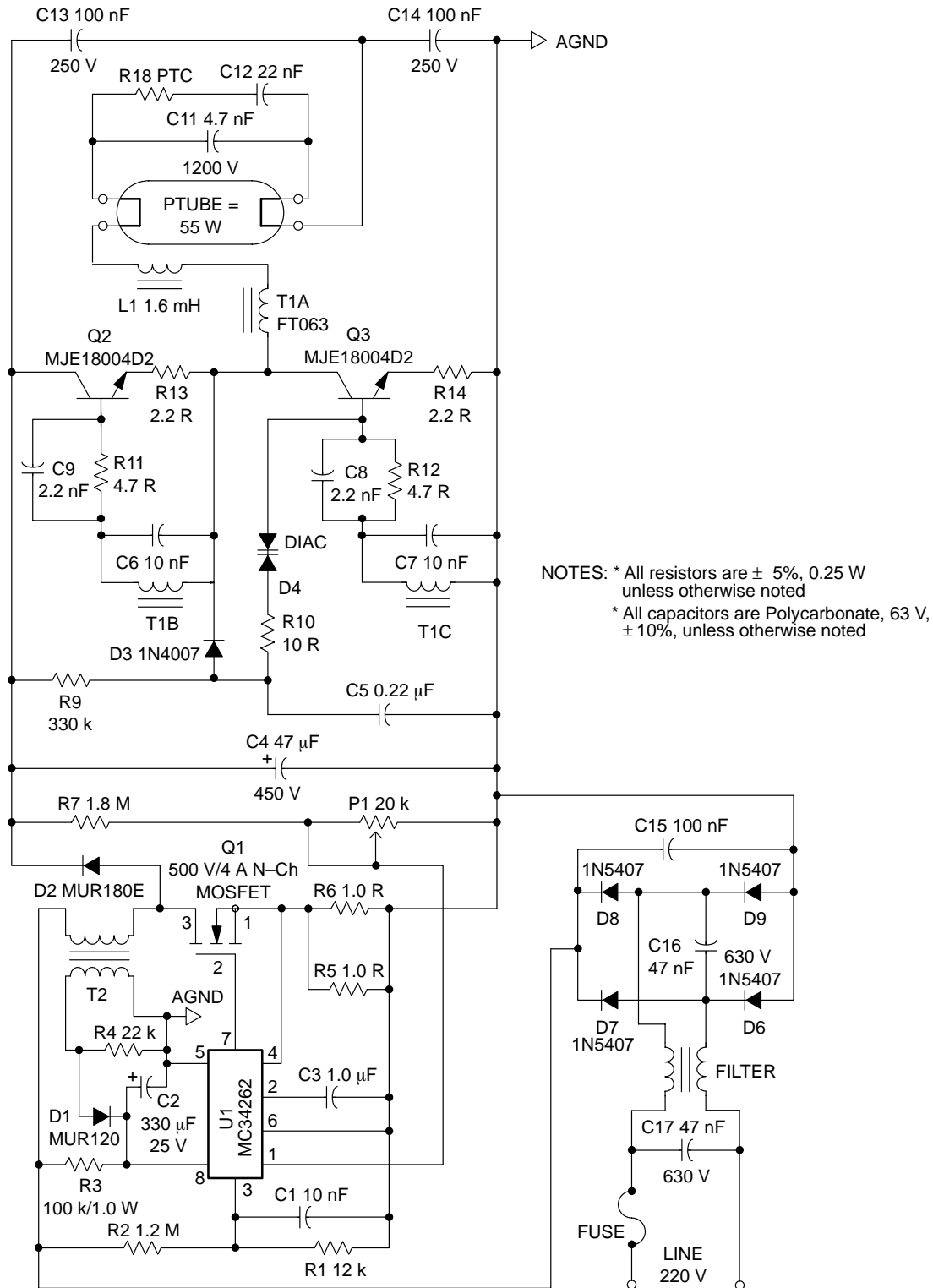


Figure 49. Efficient Safety Circuit for Electronic Ballast

## SMPSRM

### Features:

Easy to implement circuit to avoid thermal runaway when fluorescent lamp does not strike.

### ON Semiconductor Advantages:

Power devices do not have to be oversized – lower cost solution.

Includes power factor correction.

### Devices:

Part Number	Description
MC34262	Power Factor Controller
MUR120	Ultrafast Rectifier (200 V)
MJE18004D2	High Voltage Planar Bipolar Power Transistor (100 V)
1N4007	General Purpose Diode (1000 V)
1N5240B	Zener Voltage Regulator Diode (10 V)
1N5407	Rectifier (3 A, 800 V)

### \*Other Lamp Ballast Options:

	1, 2 Lamps	3, 4 Lamps
825 V	BUL642D2	BUL642D2
100 V	MJD18002D2	MJB18004D2
1200 V	MJD18202D2	MJB18204D2
		MJE18204D2

ON Semiconductor's H2BIP process integrates a diode and bipolar transistor for a single package solution.

# Application: AC-DC Battery Charger – Constant Current with Voltage Limit

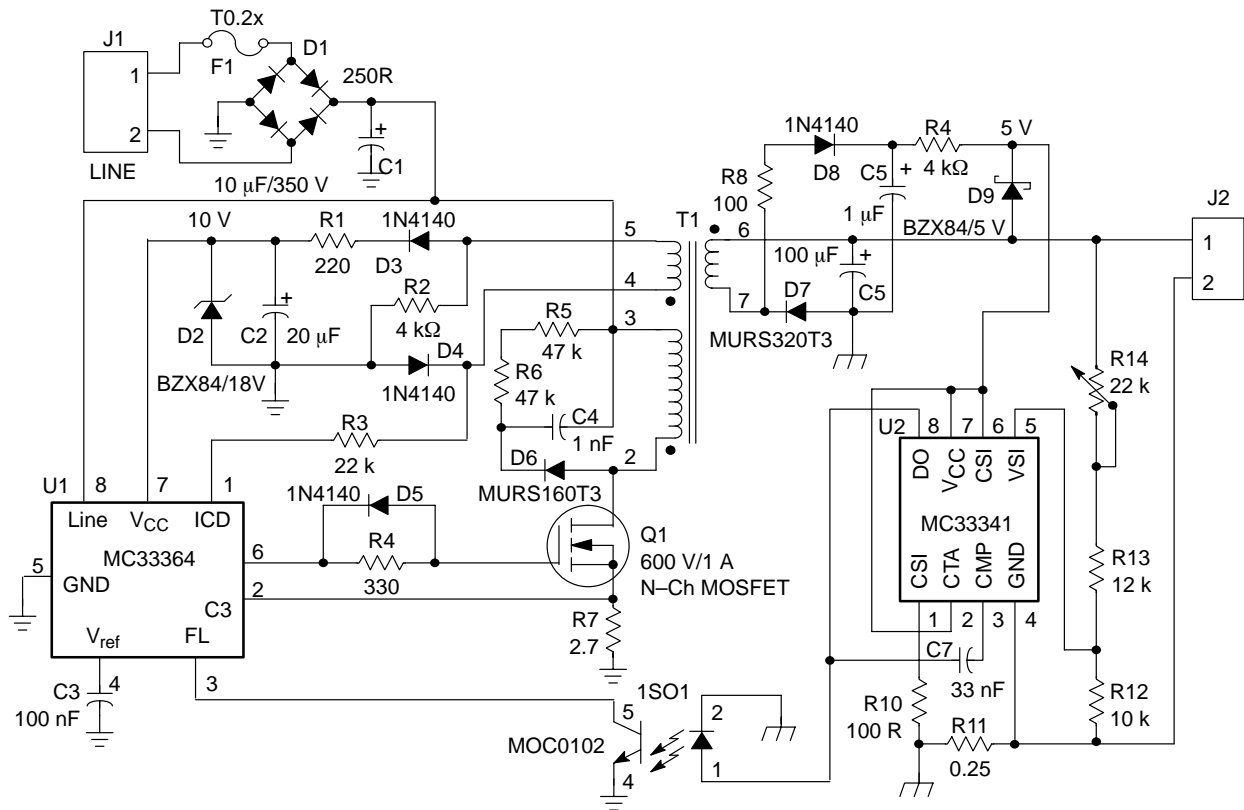


Figure 50. AC-DC Battery Charger – Constant Current with Voltage Limit

**Features:**

- Universal ac input.
- 9.5 Watt capability for charging portable equipment.
- Light weight.
- Space saving surface mount design.

**ON Semiconductor Advantages:**

- Off the shelf components
- SPICE model available for MC33341

**Devices:**

Part Number	Description
MC33341	Power Supply Battery Charger Regulator Control Circuit
MC33364	Critical Conduction SMPS Controller
MURS160T3	Surface Mount Ultrafast Rectifier (600 V)
MURS320T3	Surface Mount Ultrafast Rectifier (200 V)
BZX84C5V1LT1	Zener Voltage Regulator Diode (5.1 V)
BZX84/18V	Zener Voltage Regulator Diode (MMSZ18T1)
Transformer	For details consult AN1600



## SMPSRM

# Literature Available from ON Semiconductor

### Application Notes

*These older Application Notes may contain part numbers that are no longer available, but the applications information may still be helpful in designing an SMPS. They are available through the Literature Distribution Center for ON Semiconductor at 800-344-3860 or 303-675-2175 or by email at [ONlit@hibbertco.com](mailto:ONlit@hibbertco.com).*

- AN873 – Understanding Power Transistor Dynamic Behavior:  $dv/dt$  Effects on Switching RBSOA
- AN875 – Power Transistor Safe Operating Area: Special Consideration for Switching Power Supplies
- AN913 – Designing with T MOS Power MOSFETs
- AN915 – Characterizing Collector-to-Emitter and Drain-to-Source Diodes for Switchmode Applications
- AN918 – Paralleling Power MOSFETs in Switching Applications
- AN920 – Theory and Applications of the MC34063 and  $\mu$ A78S40 Switching Regulator Control Circuits
- AN929 – Insuring Reliable Performance from Power MOSFETs
- AN952 – Ultrafast Recovery Rectifiers Extend Power Transistor SOA
- AN1040 – Mounting Considerations for Power Semiconductors
- AN1043 – SPICE Model for T MOS Power MOSFETs
- AN1080 – External-Sync Power Supply with Universal Input Voltage Range for Monitors
- AN1083 – Basic Thermal Management of Power Semiconductors
- AN1090 – Understanding and Predicting Power MOSFET Switching Behavior
- AN1320 – 300 Watt, 100 kHz Converter Utilizes Economical Bipolar Planar Power Transistors

The following Application Notes are available directly from the ON Semiconductor website (<http://onsemi.com>).

- AN1327 – Very Wide Input Voltage Range, Off-line Flyback Switching Power Supply
- AN1520 – HDTMOS Power MOSFETs Excel in Synchronous Rectifier Applications
- AN1541 – Introduction to Insulated Gate Bipolar Transistor
- AN1542 – Active Inrush Current Limiting Using MOSFETs
- AN1543 – Electronic Lamp Ballast Design
- AN1547 – A DC to DC Converter for Notebook Computers Using HDTMOS and Synchronous Rectification
- AN1570 – Basic Semiconductor Thermal Measurement
- AN1576 – Reduce Compact Fluorescent Cost with Motorola's (ON Semiconductor) IGBTs for Lighting
- AN1577 – Motorola's (ON Semiconductor) D2 Series Transistors for Fluorescent Converters
- AN1593 – Low Cost 1.0 A Current Source for Battery Chargers
- AN1594 – Critical Conduction Mode, Flyback Switching Power Supply Using the MC33364
- AN1600 – AC-DC Battery Charger – Constant Current with Voltage Limit

## Literature Available from ON Semiconductor (continued)

- AN1601 – Efficient Safety Circuit for Electronic Ballast
- AN1628 – Understanding Power Transistors Breakdown Parameters
- AN1631 – Using PSPICE to Analyze Performance of Power MOSFETs in Step–Down, Switching Regulators Employing Synchronous Rectification
- AN1669 – MC44603 in a 110 W Output SMPS Application
- AN1679 – How to Deal with Leakage Elements in Flyback Converters
- AN1680 – Design Considerations for Clamping Networks for Very High Voltage Monolithic Off–Line PWM Controllers
- AN1681 – How to Keep a Flyback Switch Mode Supply stable with a Critical–Mode Controller

### **Brochures and Data Books**

Thermal Modeling & Management of Discrete Surface Mount Packages	BR1487/D
Analog/Interface ICs Device	DL128/D
Bipolar Device Data	DL111/D
Thyristor Device Data	DL137/D
Power MOSFETs	DL135/D
TVS/Zener Device Data	DL150/D
Rectifier Device Data	DL151/D
Master Components Selector Guide	SG388/D

### **Device Models**

Device models for SMPS circuits (MC33363 and MC33365), power transistors, rectifiers and other discrete products are available through ON Semiconductor's website or by contacting your local sales office.

## SMPSRM

### Reference Books Relating to Switching Power Supply Design

Baliga, B. Jayant,

Power Semiconductor Devices, PWS Publishing Co., Boston, 1996. 624 pages.

Brown, Marty,

Practical Switching Power Supply Design, Academic Press, Harcourt Brace Jovanovich, 1990. 240 pages.

Brown, Marty

Power Supply Cookbook, EDN Series for Design Engineers, ON Semiconductor Series in Solid State Electronics, Butterworth–Heinmann, MA, 1994. 238 pages

Chrysiss, G. C.,

High Frequency Switching Power Supplies: Theory and Design, Second Edition, McGraw–Hill, 1989. 287 pages

Gottlieb, Irving M.,

Power Supplies, Switching Regulators, Inverters, and Converters, 2nd Edition, TAB Books, 1994. 479 pages.

Kassakian, John G., Martin F. Schlect, and George C. Verghese,

Principles of Power Electronics, Addison–Wesley, 1991. 738 pages.

Lee, Yim–Shu,

Computer–Aided Analysis and Design of Switch–Mode Power Supplies, Marcel Dekker, Inc., NY, 1993

Lenk, John D.,

Simplified Design of Switching Power Supplies, EDN Series for Design Engineers, Butterworth–Heinmann, MA, 1994. 221 pages.

McLyman, C. W. T.,

Designing Magnetic Components for High Frequency DC–DC Converters, KG Magnetics, San Marino, CA, 1993. 433 pages, 146 figures, 32 tables

Mitchell, Daniel,

Small–Signal MathCAD Design Aids, e/j Bloom Associates, 115 Duran Drive, San Rafael, Ca 94903–2317, 415–492–8443, 1992. Computer disk included.

Mohan, Ned, Tore M. Undeland, William P. Robbins,

Power Electronics: Converter, Applications and Design, 2nd Edition, Wiley, 1995. 802 pages

Paice, Derek A.,

Power Electronic Converter Harmonics, Multipulse Methods for Clean Power, IEEE Press, 1995. 224 pages.

Whittington, H. W.,

Switched Mode Power Supplies: Design and Construction, 2nd Edition, Wiley, 1996 224 pages.

Basso, Christophe,

Switch–Mode Power Supply SPICE Cookbook, McGraw–Hill, 2001. CD–ROM included. 255 pages.

## Web Locations for Switching–Mode Power Supply Information

Ardem Associates (Dr. R. David Middlebrook)

<http://www.ardem.com/>

Applied Power Electronics Conference (APEC)

The power electronics conference for the practical aspects of power supplies.

<http://www.apec-conf.org/>

Dr. Vincent G. Bello's Home Page

SPICE simulation for switching–mode power supplies.

<http://www.SpiceSim.com/>

e/j BLOOM Associates

(Ed Bloom) Educational Materials & Services for Power Electronics.

<http://www.ejbloom.com/>

The Darnell Group

(Jeff Shepard) Contains an excellent list of power electronics websites, an extensive list of manufacturer's contact information and more.

<http://www.darnell.com/>

Switching–Mode Power Supply Design by Jerrold Foutz

An excellent location for switching mode power supply information and links to other sources.

<http://www.smpstech.com/>

Institute of Electrical and Electronics Engineers (IEEE)

<http://www.ieee.org/>

IEEE Power Electronics Society

<http://www.pels.org/pels.html>

Power Control and Intelligent Motion (PCIM)

Articles from present and past issues.

<http://www.pcim.com/>

Power Corner

Frank Greenhalgh's Power Corner in EDTN

<http://fgl.com/power1.htm>

Power Designers

<http://www.powerdesigners.com/>

Power Quality Assurance Magazine

Articles from present and past issues.

<http://powerquality.com/>

Power Sources Manufacturers Association

A trade organization for the power sources industry.

<http://www.pσμα.com/>

Quantum Power Labs

An excellent hypertext–linked glossary of power electronics terms.

<http://www.quantumpower.com/>

Ridley Engineering, Inc.

Dr. Ray Ridley

<http://www.ridleyengineering.com/>

## **SMPSRM**

### **Web Locations for Switching–Mode Power Supply Information (continued)**

Springtime Enterprises – Rudy Severns

Rudy Severns has over 40 years of experience in switching–mode power supply design and static power conversion for design engineers.

*<http://www.rudyseverns.com/>*

TESLAcO

Dr. Slobodan Cuk is both chairman of TESLAcO and head of the Caltech Power Electronics Group.

*<http://www.teslaco.com/>*

Venable Industries

*<http://www.venableind.com/>*

## Analog ICs for SWITCHMODE Power Supplies

A number of different analog circuits that can be used for designing switchmode power supplies can be found in our Analog IC Family Tree and Selector Guide (SGD504/D) available on our website at [www.onsemi.com](http://www.onsemi.com) or through our Literature Distribution Center, 800-344-3860 or (+1) 303-675-2175 or by email at [ONlit@hibbertco.com](mailto:ONlit@hibbertco.com). These circuits are the same as those in the Power Management and System Management sections of the ON Semiconductor Master Components Selector Guide, also available as SG388/D. Circuits used specifically for the off-line controllers and power factor controllers are in the Power Management section. Additional circuits that are frequently used with a SMPS design (dc-dc converters, voltage references, voltage regulators, MOSFET/IGBT drivers and dedicated power management controllers) are included for reference purposes. Undervoltage and overvoltage supervisory circuits are in the System Management section.

Information about the discrete semiconductors that are shown in this brochure and other discrete products that may be required for a switching power supply can also be found in the ON Semiconductor Master Components Selector Guide (SG388/D).

## ON SEMICONDUCTOR MAJOR WORLDWIDE SALES OFFICES AND REPRESENTATIVES

**UNITED STATES**

**ALABAMA**

Huntsville ..... 256-774-1010  
 Huntsville (Sales Rep) ..... 256-705-5205

**CALIFORNIA**

Del Mar (Sales Rep) ..... 858-794-1999  
 Irvine (Sales Rep) ..... 949-580-0270  
 Sacramento (Sales Rep) ... 916-652-0268  
 Santa Clara (Sales Rep) ... 408-350-3900  
 Woodland Hills (Sales Rep) . 818-226-6010

**COLORADO**

Denver (Sales Rep) ..... 303-741-0900

**CONNECTICUT**

Southbury ..... 203-267-5451

**FLORIDA**

Boca Raton ..... 561-995-1466  
 Tampa ..... 813-286-6181

**GEORGIA**

Atlanta ..... 561-995-1486  
 Norcross (Sales Rep) ..... 770-209-9242

**IDAHO**

Boise (Sales Rep) ..... 208-424-1002

**ILLINOIS**

Chicago ..... 847-330-6979  
 Itasca (Sales Rep) ..... 630-250-9586

**INDIANA**

Carmel (Sales Rep) ..... 317-848-9958  
 Kokomo ..... 765-865-2085  
 Kokomo (Sales Rep) ..... 765-455-0777

**MARYLAND**

Baltimore (Sales Rep) ..... 410-761-2255

**MASSACHUSETTS**

Boston ..... 781-376-8059  
 Burlington (Sales Rep) ..... 781-238-8888

**MICHIGAN**

Livonia ..... 734-953-6704

**MINNESOTA**

Plymouth ..... 763-249-2360

**MISSOURI**

St. Louis ..... 618-288-0620

**NEW YORK**

New York (Sales Rep) ..... 516-466-2300  
 Binghampton (Sales Rep) .. 607-722-3580  
 Rochester (Sales Rep) ..... 716-385-6500

**UNITED STATES (continued)**

**NORTH CAROLINA**

Raleigh (Sales Rep) ..... 919-845-9900

**OREGON**

Portland ..... 503-590-5852

**PENNSYLVANIA**

Philadelphia/Horsham .... 215-997-4340  
 Hatboro (Sales Rep) ..... 215-957-0600

**TEXAS**

Austin (Sales Rep) ..... 512-343-1199  
 Dallas (Sales Rep) ..... 972-680-2800  
 Houston (Sales Rep) ..... 281-999-0101

**UTAH**

Draper (Sales Rep) ..... 801-572-4010

**VIRGINIA**

Herndon (Sales Rep) ..... 703-481-9895

**WISCONSIN**

Brookfield (Sales Rep) .... 630-250-9586

**CANADA**

**ALBERTA**

Calgary (Sales Rep) ..... 403-730-6225

**BRITISH COLUMBIA**

Vancouver (Sales Rep) .... 604-532-3881

**ONTARIO**

Nepean (Sales Rep) ..... 613-596-9294  
 Toronto ..... 905-812-0092  
 Mississauga (Sales Rep) ... 905-607-1444

**QUEBEC**

Mascouche (Sales Rep) ... 450-966-9530  
 Montreal ..... 514-695-4599

**INTERNATIONAL**

**BRAZIL**

Sao Paulo ..... 55-11-5503-6560

**CHINA**

Beijing ..... 86-10-8518-2323  
 Chengdu ..... 86-28-678-4078  
 Shenzhen ..... 86-755-209-1128  
 Shanghai ..... 86-21-6875-6677

**CZECH REPUBLIC**

Roznov ..... 420 (0) 651-667-141

**FINLAND**

Vantaa ..... 358 (0) 9-85-666-460

**INTERNATIONAL (continued)**

**FRANCE**

Paris ..... 33 (0) 1-39-26-41-00  
 Toulouse ..... 33 (0) 5-34-61-10-00

**GERMANY**

Munich ..... 49 (0) 89-93-0808-0

**HONG KONG**

Hong Kong ..... 852-2689-0088

**INDIA**

Bangalore ..... 91-80-226-7272

**ISRAEL**

Herzlia ..... 972 (0) 9-9609-111

**ITALY**

Milan ..... 39 (0) 2-530-0951

**JAPAN**

Tokyo ..... 81-3-5740-2737

**KOREA**

Seoul ..... 82-2-528-2700

**MALAYSIA**

Penang ..... 60-4-226-9368

**MEXICO**

Tijuana ..... 52-6-684-2333  
 Ciudad Juarez ..... 52-1-625-0991  
 Chihuahua ..... 52-1-483-5683  
 Zapopan ..... 52-3-669-9100

**PHILIPPINES**

Muntinlupa City ..... 63-2-809-2350

**PUERTO RICO**

San Juan ..... 787-641-4100

**SINGAPORE**

Singapore ..... 65-298-1768

**SWEDEN**

Solna ..... 46 (0) 8-5090-4680

**TAIWAN**

Taipei ..... 886-2-2718-9961

**THAILAND**

Bangkok ..... 66-2-653-5031

**UNITED KINGDOM**

Aylesbury ..... 44 (0) 1296-610400

**N. AMERICAN TECHNICAL SUPPORT  
1-800-282-9855 Toll Free**

## ON SEMICONDUCTOR STANDARD DOCUMENT TYPE DEFINITIONS

### DATA SHEET CLASSIFICATIONS

A Data Sheet is the fundamental publication for each individual product/device, or series of products/devices, containing detailed parametric information and any other key information needed in using, designing-in or purchasing of the product(s)/device(s) it describes. Below are the three classifications of Data Sheet: Product Preview; Advance Information; and Fully Released Technical Data.

#### PRODUCT PREVIEW

A Product Preview is a summary document for a product/device under consideration or in the early stages of development. The Product Preview exists only until an “Advance Information” document is published that replaces it. The Product Preview is often used as the first section or chapter in a corresponding reference manual. The Product Preview displays the following disclaimer at the bottom of the first page: “This document contains information on a product under development. ON Semiconductor reserves the right to change or discontinue this product without notice.”

#### ADVANCE INFORMATION

The Advance Information document is for a device that is NOT fully qualified, but is in the final stages of the release process, and for which production is eminent. While the commitment has been made to produce the device, final characterization and qualification may not be complete. The Advance Information document is replaced with the “Fully Released Technical Data” document once the device/part becomes fully qualified. The Advance Information document displays the following disclaimer at the bottom of the first page: “This document contains information on a new product. Specifications and information herein are subject to change without notice.”

#### FULLY RELEASED TECHNICAL DATA

The Fully Released Technical Data document is for a product/device that is in full production (i.e., fully released). It replaces the Advance Information document and represents a part that is fully qualified. The Fully Released Technical Data document is virtually the same document as the Product Preview and the Advance Information document with the exception that it provides information that is unavailable for a product in the early phases of development, such as complete parametric characterization data. The Fully Released Technical Data document is also a more comprehensive document than either of its earlier incarnations. This document displays no disclaimer, and while it may be informally referred to as a “data sheet,” it is not labeled as such.

### DATA BOOK

A Data Book is a publication that contains primarily a collection of Data Sheets, general family and/or parametric information, Application Notes and any other information needed as reference or support material for the Data Sheets. It may also contain cross reference or selector guide information, detailed quality and reliability information, packaging and case outline information, etc.

### APPLICATION NOTE

An Application Note is a document that contains real-world application information about how a specific ON Semiconductor device/product is used, or information that is pertinent to its use. It is designed to address a particular technical issue. Parts and/or software must already exist and be available.

### SELECTOR GUIDE

A Selector Guide is a document published, generally at set intervals, that contains key line-item, device-specific information for particular products or families. The Selector Guide is designed to be a quick reference tool that will assist a customer in determining the availability of a particular device, along with its key parameters and available packaging options. In essence, it allows a customer to quickly “select” a device. For detailed design and parametric information, the customer would then refer to the device’s Data Sheet. The *Master Components Selector Guide* (SG388/D) is a listing of **ALL** currently available ON Semiconductor devices.

### REFERENCE MANUAL

A Reference Manual is a publication that contains a comprehensive system or device-specific descriptions of the structure and function (operation) of a particular part/system; used overwhelmingly to describe the functionality or application of a device, series of devices or device category. Procedural information in a Reference Manual is limited to less than 40 percent (usually much less).


### HANDBOOK

A Handbook is a publication that contains a collection of information on almost any give subject which does not fall into the Reference Manual definition. The subject matter can consist of information ranging from a device specific design information, to system design, to quality and reliability information.

### ADDENDUM

A documentation Addendum is a supplemental publication that contains missing information or replaces preliminary information in the primary publication it supports. Individual addendum items are published cumulatively. The Addendum is destroyed upon the next revision of the primary document.



**ON Semiconductor** and  are registered trademarks of Semiconductor Components Industries, LLC (SCILLC). SCILLC reserves the right to make changes without further notice to any products herein. SCILLC makes no warranty, representation or guarantee regarding the suitability of its products for any particular purpose, nor does SCILLC assume any liability arising out of the application or use of any product or circuit, and specifically disclaims any and all liability, including without limitation special, consequential or incidental damages. "Typical" parameters which may be provided in SCILLC data sheets and/or specifications can and do vary in different applications and actual performance may vary over time. All operating parameters, including "Typicals" must be validated for each customer application by customer's technical experts. SCILLC does not convey any license under its patent rights nor the rights of others. SCILLC products are not designed, intended, or authorized for use as components in systems intended for surgical implant into the body, or other applications intended to support or sustain life, or for any other application in which the failure of the SCILLC product could create a situation where personal injury or death may occur. Should Buyer purchase or use SCILLC products for any such unintended or unauthorized application, Buyer shall indemnify and hold SCILLC and its officers, employees, subsidiaries, affiliates, and distributors harmless against all claims, costs, damages, and expenses, and reasonable attorney fees arising out of, directly or indirectly, any claim of personal injury or death associated with such unintended or unauthorized use, even if such claim alleges that SCILLC was negligent regarding the design or manufacture of the part. SCILLC is an Equal Opportunity/Affirmative Action Employer.

---

## PUBLICATION ORDERING INFORMATION

### GLOBAL Literature Fulfillment:

Literature Distribution Center for ON Semiconductor  
P.O. Box 5163, Denver, Colorado 80217 USA  
**Phone:** 303-675-2175 or 800-344-3860 Toll Free USA/Canada  
**Fax:** 303-675-2176 or 800-344-3867 Toll Free USA/Canada  
**Email:** ONlit@hibbertco.com

**JAPAN:** ON Semiconductor, Japan Customer Focus Center  
4-32-1 Nishi-Gotanda, Shinagawa-ku, Tokyo, Japan 141-0031  
**Phone:** 81-3-5740-2700  
**Email:** r14525@onsemi.com

**ON Semiconductor Website:** <http://onsemi.com>

**N. American Technical Support:** 800-282-9855 Toll Free USA/Canada

For additional information, please contact your local Sales Representative