

TOP VIEW

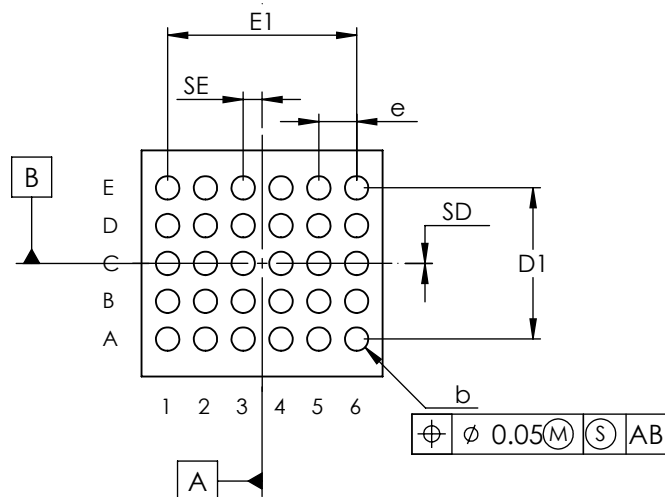

BOTTOM VIEW

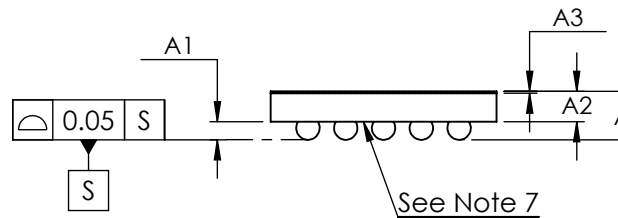

SIDE VIEW

COMMON DIMENSIONS	
A	0.64 ±0.05
A1	0.24 ±0.03
A2	0.40 REF
A3	0.025 BASIC
b	∅0.31 ±0.03
D1	2.00
E1	2.50
e	0.50 BASIC
SD	0.00 BASIC
SE	0.25 BASIC

PKG. CODE	E	D	DEPOPULATED BUMPS
W302A3+1	3.065±0.015	2.565±0.015	B2, B3, B4, C2, C3, C4, D2, D3, D4, D5
W302A3+2	3.030±0.080	2.520±0.080	NONE
W303A3+1	3.260±0.050	3.000±0.050	NONE
W303B3+1	3.205±0.015	3.005±0.015	NONE
W303C3+1	3.415±0.015	3.005±0.015	NONE

NOTES:

1. Terminal pitch is defined by terminal center to center value.
2. Outer dimension is defined by center lines between scribe lines.
3. All dimensions in millimeter.
4. Marking shown is for package orientation reference only.
5. Tolerance is ± 0.02 unless specified otherwise.
6. All dimensions apply to PbFree (+) package codes only.
7. Front - side finish can be either Black or Clear.



TITLE		
PACKAGE OUTLINE 30 BUMPS, WLP PKG. 0.5mm PITCH		
APPROVAL	DOCUMENT CONTROL NO.	REV.
	21-0016	F 1/1