

TOP VIEW

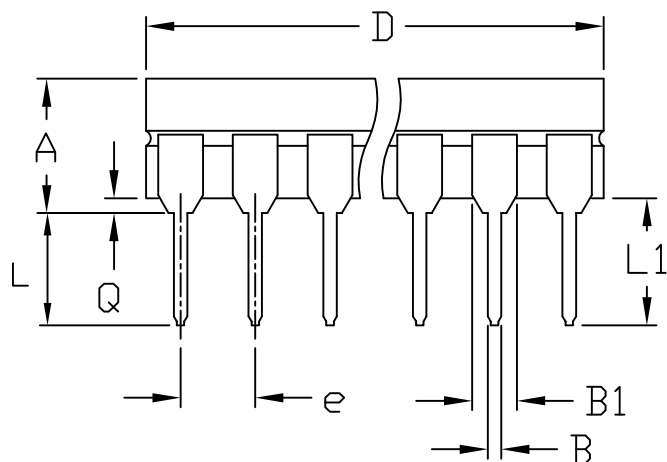

SIDE VIEW

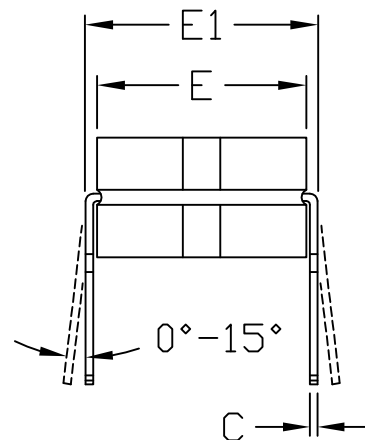

	INCHES		MILLIMETERS	
	MIN	MAX	MIN	MAX
A	---	0.200	---	5.08
B	0.014	0.023	0.36	0.58
B1	0.038	0.065	0.97	1.65
C	0.008	0.015	0.20	0.38
E	0.220	0.310	5.59	7.87
E1	0.290	0.320	7.37	8.13
e	0.100		2.54	
L	0.125	0.200	3.18	5.08
L1	0.150	---	0.00	---
Q	0.015	0.070	0.38	1.78
S	---	0.098	---	2.49
S1	0.005	---	0.13	---

	INCHES		MILLIMETERS		N	CASE
	MIN	MAX	MIN	MAX		
D	---	0.405	---	10.29	8	P:D4
D	---	0.785	---	19.94	14	C:D1
D	---	0.840	---	21.34	16	E:D2
D	---	0.960	---	24.38	18	V:D6
D	---	1.060	---	26.92	20	R:D8
D	---	1.280	---	32.51	24	L:D9

NOTES:

1. ALL DIMENSIONS ARE IN INCHES UNLESS OTHERWISE SPECIFIED.
2. MATERIAL MUST COMPLY WITH BANNED AND RESTRICTED SUBSTANCES SPEC #10-0131.
3. MEETS 1835 CASE OUTLINE CONFIGURATION #1 AS SHOWN IN ABOVE TABLE
4. N = NUMBER OF PINS
5. ALL DIMENSIONS APPLY TO LEADED (-), LEAD FREE (+) PKG. CODES.
6. PACKAGE CODE:

- J8-2
- J14-3
- J16-3
- J16-4
- J18-2
- J20-2
- R24-1
- R24-2
- R24-4

-DRAWING NOT TO SCALE-



TITLE:  
PACKAGE OUTLINE, CDIP, .300"  
8L, 14L, 16, 18L & 20L.

APPROVAL	DOCUMENT CONTROL NO. 21-0045	REV. B	1/1
----------	---------------------------------	-----------	-----