

TOP VIEW

COMMON DIMENSIONS	
A	0.62±0.05-0.08
A1	0.29±0.02
A2	0.33 REF.
b	∅0.35±0.03
D	2.54±0.08
D1	2.00 BASIC
E	2.54±0.08
E1	2.00 BASIC
e	0.50 BASIC
SD	0.00 BASIC
SE	0.00 BASIC

PKG. CODE	DEPOPULATED SOLDER BALLS
B25-1	NONE
B25-2	D2, D3, D4
B25-3	B2, B3, B4
B25-4	B3, C2, C3, C4, D3
B25-5	B2, B3, B4, C2, C4, D2, D3, D4

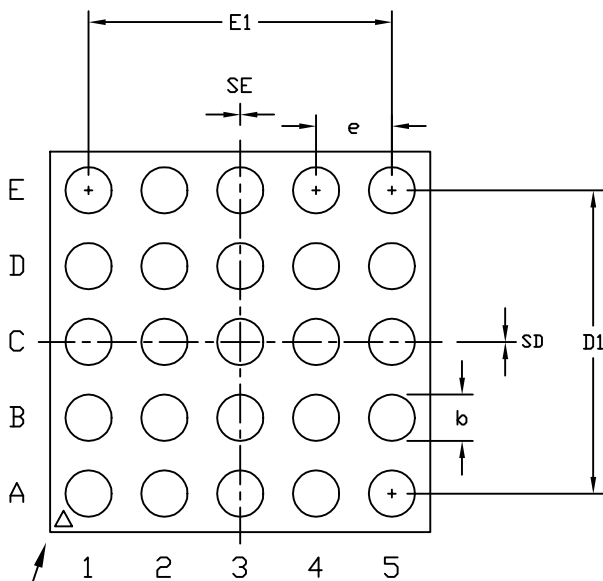

BOTTOM VIEW

NOTES:

1. All dimensions in millimeters.
2. Outer dimension (D & E) is defined by center lines between scribe lines.
3. Marking shown is for package orientation reference only. Number of characters and lines vary per product.
4. All dimensions are applicable to Leaded (-), PbFree (+), and MaxFilm parts/pkg codes.

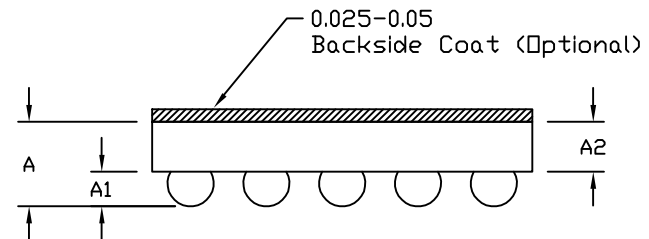

SIDE VIEW

PIN A1 INDICATOR

-DRAWING NOT TO SCALE-

MAXIM			
TITLE: PACKAGE OUTLINE, 25 BUMPS, 5X5 ARRAY, UCSP (B) PKG.			
APPROVAL	DOCUMENT CONTROL NO. 21-0096	REV. I	1/1