

TOP VIEW

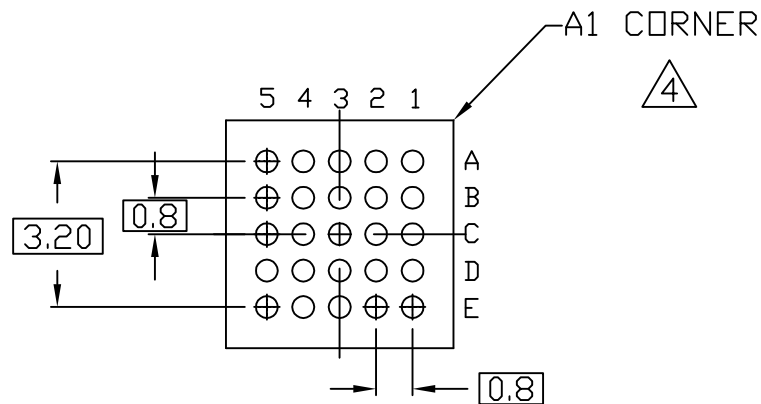

BOTTOM VIEW

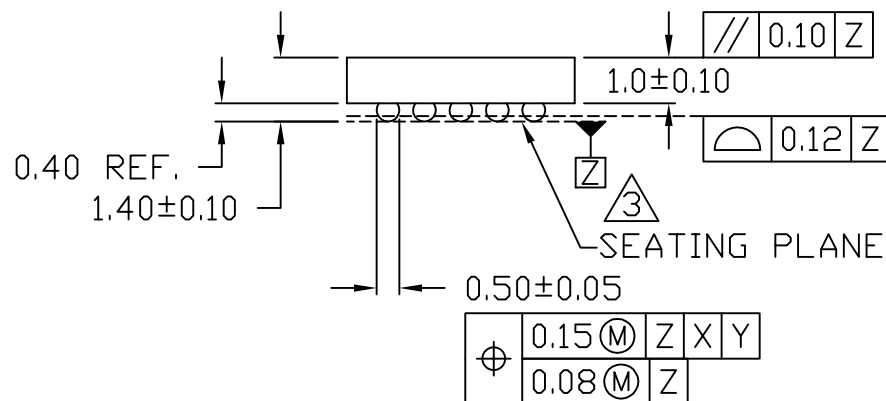

SIDE VIEW

NOTES:

1. DIMENSIONS ARE IN MILLIMETERS.
2. MATERIAL MUST COMPLY WITH BANNED AND RESTRICTED SUBSTANCES SPEC # 10-0131.
- ③ PRIMARY DATUM Z AND SEATING PLANE ARE DEFINED BY THE SPHERICAL CROWNS OF THE SOLDER BALLS.
- ④ A1 CORNER OF THE SUBSTRATE MUST BE IDENTIFIED BY METALLIZED MARKINGS.
5. COMPLIANT TO JEDEC OUTLINE MD-205, NO EXACT VARIATION.
6. ALL DIMENSIONS APPLY TO BOTH LEADED (-) AND PbFREE (+) PKG. CODES.
7. PACKAGE CODES: X25-1, X25-2, X25-3



TITLE: PACKAGE OUTLINE, 25 BALLS CSBGA, 5x5x1.0mm, 0.80 mm PITCH			
APPROVAL	DOCUMENT CONTROL NO. 21-0361	REV. B	1/1

-DRAWING NOT TO SCALE-