

TOP VIEW

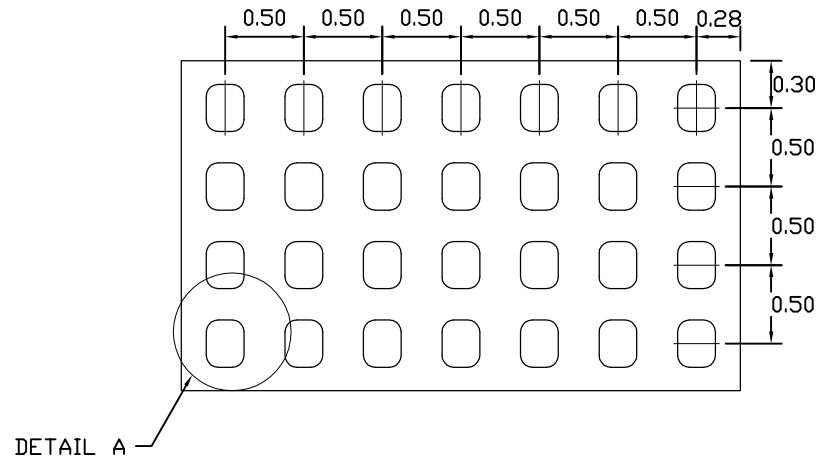

BOTTOM VIEW

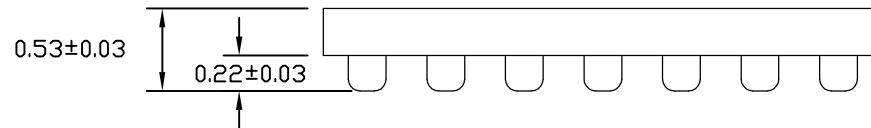
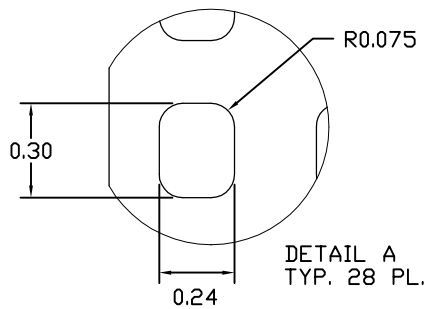

SIDE VIEW

NOTES:

1. ALL DIMENSIONS ARE IN MM,
2. TOLERANCES: ALL PAD: ±0.01mm;  
TWO PLACE DECIMAL: ±0.1mm; THREE PLACE DECIMAL: ±0.05mm
3. MARKING SHOWN IS FOR PACKAGE ORIENTATION ONLY
4. ALL DIMENSIONS APPLY TO PBFREE (+) PKGCODE ONLY
5. PACKAGE CODE: A282A3+1



TITLE:  
PACKAGE OUTLINE, 28L  
WAFER LEVEL QFN PKG, 2.10x3.56 MM

APPROVAL	DOCUMENT CONTROL NO. 21-0722	REV. A	1/1
----------	---------------------------------	-----------	-----