

TOP VIEW

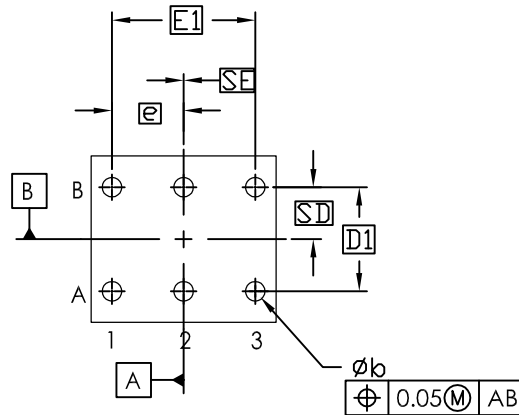

BOTTOM VIEW

DIMENSIONS	
A	0.51±0.05
A1	0.24±0.03
A2	0.27 REF
A3	0.040 BSC
b	0.30±0.03
D1	1.60 BSC
E1	2.20 BSC
e	1.10 BSC
SD	0.80 BSC
SE	0.00 BSC

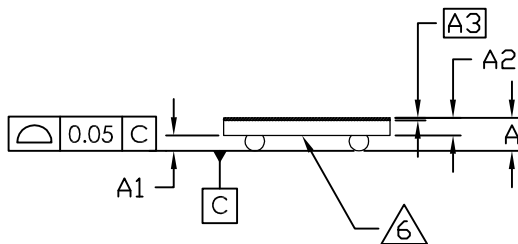

SIDE VIEW

PKG CODE	E	D	DEPOPULATED BUMPS
N62A2+1	2.838±0.025	2.558±0.025	NONE

NOTES:

1. ALL DIMENSIONS ARE IN MILLIMETERS UNLESS OTHERWISE SPECIFIED.
2. TERMINAL PITCH IS DEFINED BY TERMINAL CENTER TO CENTER VALUE.
3. OUTER DIMENSION IS DEFINED BY CENTER LINES BETWEEN SCRIBE LINES.
4. MARKING SHOWN IS FOR PACKAGE ORIENTATION REFERENCE ONLY.
5. TOLERANCE IS ± 0.02 UNLESS SPECIFIED OTHERWISE.
6. FRONT - SIDE FINISH CAN BE EITHER BLACK OR CLEAR.
7. MATERIAL MUST BE COMPLIANT WITH MAXIM SPECIFICATION 10-0131 FOR SUBSTANCE CONTENT, MUST BE EU ROHS COMPLIANT WITHOUT EXEMPTION AND PB-FREE.
8. ALL DIMENSIONS APPLY TO PbFREE (+) PKG. CODE ONLY.

-DRAWING NOT TO SCALE-



TITLE:
PACKAGE OUTLINE, 6 BUMPS WLP,
CUSTOM PITCH

APPROVAL

DOCUMENT CONTROL NO.
21-0729

REV.
A

1/1