



SECTION	TITLE	PAGE
<b>1</b>	<b>GENERAL INFORMATION</b>	<b>3</b>
	Ordering Information	5
	Table and Design Aid	7
	Table and Design Aid	8
	Comparison Table	9
	Comparison Table	10
	Competitive Cross Reference Guide	11
<b>2</b>	<b>PACKAGE TYPES</b>	<b>15</b>
<b>3</b>	<b>OPERATIONAL AMPLIFIERS</b>	<b>21</b>
	516 Operational Amplifier	23
	531 High Slew Rate Operational Amplifier	25
	533 Micropower Operational Amplifier	31
	536 FET Input Operational Amplifier	35
	537 Precision Operational Amplifier	39
	LM101A High Performance Operational Amplifier	45
	LM101 High Performance Amplifier	51
	LM107 General Purpose Operational Amplifier	57
	5556 Operational Amplifier	61
	5558 Dual Operational Amplifier	65
	μA709 Operational Amplifier	67
	μA740 FET Input Operational Amplifier	69
	μA741 High Performance Operational Amplifier	71
	μA747 Dual Operational Amplifier	75
	μA748 High Performance Operational Amplifier	81
<b>4</b>	<b>VOLTAGE REGULATORS</b>	<b>85</b>
	550 Precision Voltage Regulator	87
	LM109 Five Volt Regulators	93
	μA723 Precision Voltage Regulator	97
<b>5</b>	<b>COMPARATORS AND SENSE AMPLIFIERS</b>	<b>103</b>
	518 Voltage Comparator	105
	526 Analog Voltage Comparator	107
	527 High Speed Voltage Comparator	109
	529 High Speed Voltage Comparator	113
	μA710 Differential Voltage Comparator	117
	μA711 Dual Voltage Comparator	119
	528 Four Channel Plated Wire Memory Sense Amplifier	121
	SN7520 Series Dual Core Memory Sense Amplifiers	125
<b>6</b>	<b>COMMUNICATIONS CIRCUITS</b>	<b>133</b>
	501 Video Amplifiers	135
	592 Video Amplifier	137
	μA733 Differential Video Amplifier	139
	511 Dual Differential Amplifier	145
	515 Differential Amplifier	147
	510 Dual Differential Amplifier	151
	PA239 Dual Low Noise Preamplifier	153
	5595 Linear Four-Quadrant Multiplier	155
	5596 Balanced Modulator-Demodulator	157
	75450 Dual Peripheral Driver	159
	75451 Dual Peripheral Driver	161
<b>7</b>	<b>CONSUMER CIRCUITS</b>	<b>163</b>
	540 Power Driver	165
	555 Timer	173
	5070 Series Television Chroma System	175
	5070 Chroma Signal Processor	177
	5071 Chroma Amplifier	179
	5072 Chroma Demodulator	181
	ULN2111 FM Detector and Limiter	183
<b>8</b>	<b>PHASE LOCKED LOOPS</b>	<b>189</b>
	560 Phase Locked Loop	191
	561 Phase Locked Loop	197
	562 Phase Locked Loop	203
	565 Phase Locked Loop	209
	566 Function Generator	215
	567 Tone Decoder Phase Locked Loop	219
<b>9</b>	<b>DEFINITION OF TERMS</b>	<b>229</b>
<b>10</b>	<b>SALES OFFICES</b>	<b>235</b>
<b>OTHER SIGNETICS' PRODUCTS</b>		
	ECL PRODUCT LINE	20
	BIPOLAR DIGITAL FAMILY PRODUCT LINE	102
	MOS PRODUCT LINE	234

**Copyright 1972**  
**SIGNETICS CORPORATION**

Signetics Corporation reserves the right to make changes in the products contained in this book in order to improve design or performance and to supply the best possible product.

Signetics Corporation assumes no responsibility for the use of any circuits described herein and makes no representations that they are free from patent infringement.



**25% to 50% recycled paper**

# SECTION 1

## general information



SIGNETICS ■ ORDERING INFORMATION

DEVICE	PKG	ORDER PART NUMBER		
		0°C to +70°C	-55°C to +125°C	DICE (+25°C)
501	A G K	NE501A NE501G NE501K	SE501G SE501K	501X
510	A J	NE510A NE510J	SE510A SE510J	510X
511	B R	NE511B NE511R	SE511B SE511R	511X
515	A G K	NE515A NE515G NE515K	SE515G SE515K	515X
516	A G K	NE516A NE516G NE516K	SE516A SE516G SE516K	516X
518	A G K	NE518A NE518G NE518K	SE518A SE518G SE518K	518X
526	A G K	NE526A NE526G NE526K	SE526A SE526G SE526K	526X
527	K	NE527K	SE527K	527X
528	B E R	NE528B NE528E	SE528E SE528R	528X
529	K	NE529K	SE529K	529X
531	G T V	NE531G NE531T NE531V	SE521G	531X
533	G V T	NE533G NE533V NE533T	SE533G SE533T	533X
536	G T	NE536T	SU536G SU536T*	536X
537	G T	NE537G NE537T	SE537G SE537T	537X
PA239	A	PA239A		239X
540	L	NE540L	SE540L	540X
550	A L	NE550A NE550L	SE550L	550X
555	T V	NE555T NE555V	SE555T	555X
560	B	NE560B		560X
561	B	NE561B		561X
562	B	NE562B		562X
565	A K	NE565A NE565K	SE565K	565X
566	T V	NE566T NE566V	SE566T	566X
567	T V	NE567T NE567V	SE567T	567X
592	A K	NE592A NE592K	SE592K	592X
μA709	A G T V	μA709CA μA709CG μA709CT μA709CV	μA709AA μA709A μA709G μA709AT μA709T	709X
μA710	A V T G	μA710CA μA710CV μA710CT μA710CG	μA710T μA710G	710X
μA711	A G K	μA711CA μA711CG μA711CK	μA711G μA711K	711X

DEVICE	PKG	ORDER PART NUMBER		
		0°C to +70°C	-55°C to +125°C	DICE (+25°C)
μA723	L A	μA723CL μA723CA	μA723L	723X
μA733	A K F	μA733CA μA733CK μA733CF	μA733K μA733F	733X
μA740	T	μA740CT	μA740T	740X
μA741	A G V T	μA741CA μA741CG μA741CV μA741CT	μA741G μA741V μA741T	741X
μA747	A K	μA747CA μA747CK	μA747A μA747K	747X
μA748	A T V	μA748CA μA748CT μA748CV	μA748T	748X
ULN2111	A	ULN2111		2111X
5070	B	N5070B		5070X
5071	A	N5071A		5071X
5072	A	N5072A		5072X
5556	T F V	N5556T N5556F N5556V	S5556T S5556F	5556X
5558	V T F	N5558V N5558T N5558F	S5558T S5558F	5558X
5595	A F	N5595A N5595F	S5595F	5595X
5596	A K F	N5596A N5596K N5596F	S5596K S5596F	5596X
7520	B	SN7520N		7520X
7521	B	SN7521N		7521X
7522	B	SN7522N		7522X
7523	B	SN7523N		7523X
7524	B	SN7524N		7524X
7525	B	SN7525N		7525X
75450	A	SN75450N		75450X
75450A	A	SN75450AN		75450AX
75451	V	SN75450P		75450X
75451A	V	SN75450AP		75450AX

\*Temperature Range @ -55°C to 85°C

**SIGNETICS ■ ORDERING INFORMATION**

DEVICE	PKG	ORDER PART NUMBER			
		0°C to +70°C	-55°C to +125°C	-20°C to +85°C	DICE (+25°C)
LM101D	F		LM101D		Note 1
LM101H	T		LM101H		Note 1
LM101F	G		LM101F		Note 1
LM101N	V		LM101N		Note 1
LM101N-14	A		LM101N-14		Note 1
LM101AH	T		LM101AH		Note 1
LM101AF	G		LM101AF		Note 1
LM101AD	F		LM101AD		Note 1
LM101AN	V		LM101AN		Note 1
LM101AN-14	A		LM101AN-14		Note 1
LM201D	F	LM201D			Note 1
LM201F	G	LM201F			Note 1
LM201H	T	LM201H			Note 1
LM201N	V	LM201N			Note 1
LM201N-14	A	LM201N-14			Note 1
LM201AH	T			LM201AH	Note 1
LM201AF	G			LM201AF	Note 1
LM201AD	F			LM201AD	Note 1
LM201AN	V			LM201AN	Note 1
LM201AN-14	A			LM201AN-14	Note 1
LM301AH	T	LM301AH			301AX
LM301AN	V	LM301AN			301AX
LM301AN-14	A	LM301AN-14			Note 1
LM301AD	F	LM301AD			Note 1
LM301AF	G	LM301AF			Note 1
LM107H	T		LM107H		Note 1
LM107F	G		LM107F		Note 1
LM107D	F		LM107D		Note 1
LM207H	T			LM207H	Note 1
LM207F	G			LM207F	Note 1
LM207D	F			LM207D	Note 1
LM307N	V	LM307N			307X
LM307H	T	LM307H			307X
LM307F	G	LM307F			307X
LM108H	T		LM108H		Note 1
LM108F	G		LM108F		Note 1
LM308H	T	LM308H			308X
LM308F	G	LM308F			308X
LM109H	DB		LM109H		Note 1
LM109K	DA		LM109K		Note 1
LM209H	DB			LM209H	Note 1
LM209K	DA			LM209K	Note 1
LM309H	DB	LM309H			309X
LM309K	DA	LM309K			309X

**NOTE:**

1. Most dice are available over the military temperature range.

**EXPLANATION**

The following table has been presented to assist the designer in selecting the optimum device for his application. For the majority of applications, the primary considerations are "Input Bias Current" and "Offset Voltage". For additional specifications refer to the appropriate device data page.



**SIGNETICS ■ TABLE AND DESIGN AID**

**DEVICE APPLICATIONS**

INPUT CURRENT (nA)		SIGNETICS NUMBER	PACKAGE TYPE
MAXIMUM	TYPICAL		
0.012	0.005	SU536	T
0.030	0.010	NE536	T
0.200	0.100	μA740	T
2.0	0.100	μA740C	T
2.0	0.8	SE537	T
2.0	0.8	LM108	T
2.0	0.8	LM108A	T
7.0	1.5	NE537	T
7.0	1.5	LM308	T
7.0	1.5	LM308A	T
10.0	2.0	SE533	T
10.0	5.0	NE533	T, V
15.0	8.0	S5556	T
30.0	15.0	N5556	T, V
75.0	30.0	LM101A	T
75.0	30.0	LM107	T
250.0	70.0	LM301A	T, V
500.0	80.0	μA748	T
500.0	80.0	μA748C	A, T, V
500.0	120.0	LM101	T
500.0	200.0	μA709	T
500.0	200.0	μA741C	A, T, V
500.0	200.0	μA741	A, T, V
500.0	200.0	SE531	T
1500.0	250.0	LM201	A, T, V
1500.0	300.0	μA709	A, T, V
1500.0	400.0	NE531	T, V
OFFSET VOLTAGE (mV)		SIGNETICS NUMBER	PACKAGE TYPE
MAXIMUM	TYPICAL		
0.5	0.3	LM108A	T
0.5	0.3	LM308A	T
1.0	0.5	SE533	T
2.0	0.6	SE537	T
2.0	0.7	LM101	T
2.0	0.7	LM107	T
2.0	0.7	LM108	T
2.0	1.0	NE533	T, V
5.0	1.0	LM101	T
5.0	1.0	μA709	T
5.0	1.0	μA741	T
5.0	1.0	μA748	T
5.0	2.0	NE531	T
5.0	2.0	S5556	T
6.0	1.0	μA741C	A, T, V
5.0	2.0	NE531	T, V
6.0	2.0	μA748C	A, T, V
7.5	1.6	NE537	T
7.5	1.6	LM201	A, T, V
7.5	2.0	LM301	T, V
7.5	2.0	LM308	T
7.5	2.0	μA709C	A, T, V
10.0	4.0	N5556	T, V
20.0	10.00	μA740	T
50.0	20.0	SU536	T
100.0	30.0	μA740	T
100.0	50.0	NE536	T

**EXPLANATION**

The following tables are presented as a convenience to the designer for the purpose of comparing commercially available modular and hybrid FET input op amps with Signetics 536 FET input LIC series. Substantial cost savings, as well as size and weight reductions can now be realized. For additional specifications please refer to the appropriate device data page.

ANALOG DEVICES	MODULAR FET-OP AMPS															HYBRID FET-OP AMPS										SIGNETICS 536	Units		
	40			41			42			45			47			142			146		149		501					503	
Model	J	K	JV	KV	LV	J	K	L	J	K	A	B	A	B	C	J	K	A	B	A	B	C	J	K	J	J	J	536	
Input Current Max. 25°C	50	20	0.5	0.25	0.15	0.5	0.25	0.15	50	25	50	25	50	25	25	30	20	30	15	25	10	5	25	10				12	PA
Offset Drift Max.	50	20	25	10	25	75	25	75	50	15	50	15	50	25	15	7	2	25	15	75	25	25	75	25					μV/°C
CMRR Typ.	80*	80*	80	80	80	66*	66*	66*	70*	70*	86	86	66*	66*	66*	80*	80*	80*	80*	80*	80*	80*	70	70				70	dB
Gain Band Width Product	4	4	1	1	1	0.5	0.5	0.5	10	10	10	10	5	5	5	5	5	15	15	4	4	4					1	MHz	
Slew Rate	6	6	3	3	3	0.2	0.2	0.2	75	75	50	50	10	10	10	10	10	100	100	3	3	3	4	4	4	30	30	6	V/μS
Output Current	5	5							20	20	20	20	20	20	20	20	20	15	15	5	5	5					30	mA	
Temperature Range	C	C							I	I	I	I	I	I	I	C	C	I	I	I	I	I	C	C	C	C	-20°C +85°C		

M = -55 - +125  
I = -25 - +85  
C = -0 - +70

\* = CMRR Over Reduced Voltage Range

\* = CMRR Over Reduced Common Mode Voltage Range

# SIGNETICS ■ COMPARISON TABLE

TELEDYNE PHILBRICK Model Version	MODULAR FET-OP AMPS			HYBRID FET-OP AMPS			MODULAR FET-OP AMPS												SIGNETICS 536	Units														
	QFT-2			1408			1414			1009		1003		1021		1023		1408			QFT-5			1011			1019			1025				
	O	A	B	10	00	10	00	01	02	00	01	00	01	00	01	00	01	00			01	02	00	01	02	00	01	02	00	01	02	00	01	02
Input Current Max. 25°C	100	100	100	5	150	150	30	20	20	10	5	10	10	10	25	10	5	100	30	20	20	50	50	12	pA									
Offset Drift Max.							75	50	25	4	2	50	5	2	75	25	25	300	50	25	10	25	25		μV/°C									
CMRR Typ.	70	70	70	25	50	50	60	60	60	120	120	120	120	120	80	80	80	60	66	66	66	100	*	70	dB									
Gain Band Width Product	1.7	1.7	1.7	80	66	66	1	1	1	1.5	1.5	2	2	2	2	4	4	4	1.7	12	12	12	100	50	1	MHz								
Slew Rate	10	10	10	4	10	10	5	5	5	7	7	6	6	6	6	6	6	5	70	70	70	1000	650	6	V/μS (typ.)									
Output Current	10	10	10	6	50	50	5	5	5	20	20	20	20	20	20	5	5	5	20	20	20	20	20	50	30	mV								
Temperature Range	I	I	I	I	I	I	I	I	I	C	C	I	C	C	I	I	I	I	I	I	I	I	I	I	I	-20°C +85°C								

M - 55 + 125  
 I - 25 + 85  
 C - 0 + 70  
 \* = Inverting Only

ZELTEX Model Version	MODULAR FET-OP AMPS												HYBRID FET-OP AMPS						SIGNETICS 536	Units
	ZA 801			ZA 802			ZA 803	133			134		135	136	ZA 801					
	M1	M2	M3	M1	M2	M1	00	03	04	0	D			D1	E1	T1				
Input Current Max. 25°C	25	25	25	5	5	2	10	10	10	100	100	100	100	25	25	25	12	pA		
Offset Drift Max.	50	20	5	50	20	10	50	4	10	50	100	20	25	50	50	50	μV/°C			
CMRR Typ.	80	80	80	100	100	100	86	86	86	60*	60*	100	100	80	80	80	70	dB		
Gain Band Width Product	4	4	4	2	2	2	1.5	1.5	1.5	1.3	1.3	5	1	4	4	4	1	MHz		
Slew Rate (min.)	6	6	6	6	6		6	6	6	6	6	100	25	6	6	6	6	V/μS		
Output Current	7	7	7	7	7	7	5	5	5	4	4	20	20 (+100)	7	7	7	30	mA		
Temperature Range	I	I	I	I	I	I	I	C	I	I	I	I	I	I	I	I	-20°C +85°C			

\* = CMRR Over Reduced C.M. Voltage Range

BURR-BROWN Model Version	MODULAR FET-OP AMPS												HYBRID FET-OP AMPS												SIGNETICS 536	Units
	3420			3421			3308	3307	3312	3313	3310	3311	3317	3318	3348	3349	3350	3503								
	J	K	L	J	K	L	12C	12C	12C	12C	12C	14	14	03	03	03	A	B	C	R	S	T				
Input Current Max. 25°C	10	4	1	0.5	0.1	0.2	50	20	20	50	2	2	20	50	10	10	50	25	10	1	25	10	1	12	pA	
Offset Drift Max.	5	2	1	50	25	10	50	20	20	50	10	25	20	50	5	10	20	75	25	50	75	25	50	μV/°C		
CMRR Typ.	90*	90*	90*	80	80	80	80*	80*	92	92	100	100	80*	80*	80	80	80	86	86	86	86	86	86	70	dB	
Gain Band Width Product	1	1	1	.25	.25	.25	4	4	3	3	1	1	3	3	1	1	1	1	1	1	1	1	1	1	MHz	
Slew Rate (min.)	1	1	1	0.3	0.3	0.3	6	6	6	6	6	6	6	6	3	3	3	2.5	2.5	2.5	2.5	2.5	2.5	6	V/μS (typ.)	
Output Current	10	10	10	10	10	10	5	5	5	5	5	5	5	20	5	5	5	5	5	5	5	5	5	5	30	mA
Temperature Range	C	C	C	C	C	C	I	I	I	I	I	I	I	I	I	I	I	I	I	I	M	M	M	-20°C +85°C		

M - 55 + 125  
 I - 25 + 85  
 C - 0 + 70  
 \* = CMRR Over Reduced C.M. Voltage Range

SIGNETICS ■ COMPETITIVE CROSS REFERENCE GUIDE

ANALOG DEVICES	SIGNETICS DIRECT REPLACEMENT		SIGNETICS FUNCTIONAL EQUIVALENT	
	OLD	NEW	OLD	NEW
AD710CN	N5710A	μA710CA		
AD710CH	N5710T	μA710CT		
AD710H	S5710T	μA710T		
AD711CN	N5711A	μA711CA		
AD711CH	N5711K	μA711CK		
AD711H	S5711K	μA711K		
AD741CN	N5741A	μA741CA		
AD741CH	N5741T	μA741CT		
AD741H	S5741T	μA741T		
AD301AH	N53A1T	LM301AH		
AD201AH	N52A1T	LM201AH		
AD101AH	S51A1T	LM101AH		
AD308H	N5308T	LM308H		
AD108H	S5108T	LM108H		

FAIRCHILD	SIGNETICS DIRECT REPLACEMENT		SIGNETICS FUNCTIONAL EQUIVALENT	
	OLD	NEW	OLD	NEW
U5B7709312	S5709T	μA709T		
U5B7709393	N5709T	μA709CT		
U6A7709393	N5709A	μA709CA		
U5B7710312	S5710T	μA710T		
U5B7710393	N5710T	μA710CT		
U6A7710393	N5710A	μA710CA		
U5F7711312	S5711K	μA711K		
U5E7711393	N5711K	μA711CK		
U6A7711393	N5711A	μA711CA		
U5R7723312	S5723L	μA723L		
U5R7723393	N5723L	μA723CL		
U6A7723393	N5723A	μA723CA		
U5F7733312	S5733K	μA733K		
U5F7733393	N5733K	μA733CK		
U6A7733393	N5733A	μA733CA		
U6A7733312	S5733F	μA733F		
U5B7740312	S5740T	μA740T		
U5B7740393	N5740T	μA740CT		
U5B7741312	S5741T	μA741T		
U5B7741393	N5741T	μA741CT		
U6A7741393	N5741A	μA741CA		
U9T7741393	N5741V	μA741CV		
U7A7747312	S5747A	μA747A		
U7A7747393	N5747A	μA747CA		
U5F7747312	S5747K	μA747K		
U5F7747393	N5747K	μA747CK		
U5B7748312	S5748T	μA748T		
U5B7748393	N5748T	μA748CT		
U6A7748393	N5748A	μA748CA		
U9T7748393	N5748V	μA748CV		
SN7524	N7524B	SN7425N		
SN7525	N7525B	SN7525N		

# SIGNETICS ■ COMPETITIVE CROSS REFERENCE GUIDE

MOTOROLA	SIGNETICS DIRECT REPLACEMENT		SIGNETICS FUNCTIONAL EQUIVALENT	
	OLD	NEW	OLD	NEW
MC1456G	N556T	N556T		
MC1458L	N5558F	N5558F		
MC1458G	N5558T	N5558T		
MC1495L	N5595F	N5595F		
MC1496G	N5596K	N5596K		
MC1556G	S556G	S556G		
MC1558L	S558F	S558F		
MC1558G	S558T	S558T		
MC1595L	S5595F	S5595F		
MC1596G	S5596K	S5596K		
MC1709CP	N5709A	μA709CA		
MC1709CG	N5709T	μA709CT		
MC1709F	S5709G	μA709G		
MC1709G	S5709T	μA709T		
MC1710CP	N5710A	μA710CA		
MC1710CG	N5710T	μA710CT		
MC1710F	S5710G	μA710G		
MC1710G	S5710T	μA710T		
MC1711CP	N5711A	μA711CA		
MC1711G	N5711K	μA711CK		
MC1711G	S5711K	μA711K		
MC1741CP	N5741A	μA741CA		
MC1741CG	N5741T	μA741CT		
MC1741G	S5741T	μA741T		
MC7520P	N7520B	SN7520N		
MC7521P	N7521B	SN7521N		
MC7522P	N7522B	SN7522N		
MC7523P	N7523B	SN7523N		
MC7524P	N7524B	SN7524N		
MC7525P	N7525B	SN7525N		
MC1445G			N5733K	μA733CK
MC1460			N5723L	μA723CL
MC1460R			S5723L	μA723L
MC1461G			N5723L	μA723CL
MC1461R			N5723L	μA723CL
MC1463R			N5723L	μA723CL
MC1469R			N5723L	μA723CL
MC1519G			S5733K	μA733K
MC1536G			S5741T	μA741T
MC1545G			S5733K	μA733K
MC1545L			S5733F	μA733F
MC1546L			S5733F	μA733F
MC1560G			S5723L	μA723L
MC1560R			S5723L	μA723L
MC1561G			S5723L	μA723L
MC1561R			S5723L	μA723L
MC1563R			S5723L	μA723L
MC1569R			S5723L	μA723L
MFC4060			N5723L	μA723L

NATIONAL	SIGNETICS DIRECT REPLACEMENT		SIGNETICS FUNCTIONAL EQUIVALENT	
	OLD	NEW	OLD	NEW
LM101H	S5101T	LM101H		
LM101AH	S51A1T	LM101AH		
LM101AF	S51A1G	LM101AF		
LM101AD	S51A1A	LM101AD		
LM107H	S5107T	LM107H		
LM107F	S5107G	LM107F		
LM107D	S5107A	LM107D		
LM201D	N5201A	LM201D		
LM201H	N5201T	LM201H		
LM201N	N5201V	LM201N		
LM201AH	N51A1T	LM201AH		
LM201AF	N51A1G	LM201AF		
LM201AD	N51A1A	LM101AD		
LM207H	S5107T	LM107H		
LM207F	S5107G	LM107F		
LM207D	S5107A	LM207D		
LM301AH	N53A1T	LM301AH		
LM301AN	N53A1V	LM301AN		
LM307H	N5307T	LM307H		
LM308H	N5308T	LM308H		
LM308AH	N53A8T	LM308AH		
LM309H	N5309H	LM309H		
LM309K	N5309K	LM309K		
LM709CH	N5709A	μA709CA		
LM709F	S5709G	μA709G		
LM709H	S5709T	μA709T		
LM710CN	N5710A	μA710CA		
LM710CH	N5710T	μA710CT		
LM710F	S5710G	μA710G		
LM710H	S5710T	μA710T		
LM711CN	N5711A	μA711CA		
LM711CH	N5711K	μA711CK		
LM711H	S5711K	μA711K		
LM723CN	N5723A	μA723CA		
LM723CH	N5723L	μA723CL		
LM723H	S5723L	μA723L		
LM741CH	N5741T	μA741CT		
LM741CN	N5741V	μA741CV		
LM741H	S5741T	μA741T		
LM748CH	N5748T	μA748CT		
LM748H	S5748T	μA748T		
LM1458H	N5558T	N5558T		
LM1458N	N5558V	N5558V		
LM1558H	S5558T	S5558T		
LM7520N	N7520B	SN7520N		
LM7521N	N7521B	SN7521N		
LM7522N	N7522B	SN7522N		
LM7523N	N7523B	SN7523N		
LM7524N	N7524B	SN7524N		
LM7525N	N7525B	SN7525N		
LH740ACH	N5740T	μA740CT		
LH740AH	S5740T	μA740T		
LH201			S5741T	μA741T
LH740A			N5741T	μA741CT
LH740A			S5740T	μA740T
LH700AC			N5740T	μA740CT
LM100			S5723L	μA723L
LM104			S5723L	μA723L
LM105			S5723L	μA723L
LM106			S5710T	μA710T
LM110			S5741T	μA741T
LM210			S5741T	μA741T
LM300			N5723L	μA723CL
LM304			N5723L	μA723CL
LM306			N5710T	μA710CT
LM310			N5741T	μA710CT

## SIGNETICS ■ COMPETITIVE CROSS REFERENCE GUIDE

RAYTHEON	SIGNETICS DIRECT REPLACEMENT		SIGNETICS FUNCTIONAL EQUIVALENT	
	OLD	NEW	OLD	NEW
RL709T	N5709T	μA709CT		
RM7090	S5709G	μA709G		
RM709T	S5709T	μA709T		
SG710CN	N5710A	μA710CA		
SG710CT	N5710T	μA710CT		
SG710T	S5710T	μA710T		
RL711T	N5711K	μA711CK		
RM711T	S5711K	μA711K		
RL733T	N5733K	μA733CK		
RM733T	S5733K	μA733K		
RC741T	N5741T	μA741CT		
RM741T	S5741T	μA741T		
RL101T	N5201T	LM201H		
RM101T	S5101T	LM101H		

SILICON GENERAL	SIGNETICS DIRECT REPLACEMENT		SIGNETICS FUNCTIONAL EQUIVALENT	
	OLD	NEW	OLD	NEW
SG709CN	N5709A	μA709CA		
SG709CT	N5709T	μA709CT		
SG709T	S5709T	μA709T		
SG710CN	N5710A	μA710CA		
SG710CT	N5710T	μA710CT		
SG710T	S5710T	μA710T		
SG711CN	N5711A	μA711CA		
SG711CT	N5711K	μA711CK		
SG711T	S5711K	μA711K		
SG723CN	N5723A	μA723CA		
SG723CT	N5723L	μA723CL		
SG723T	S5723L	μA723L		
SG733CN	N5733A	μA733CA		
SG733CT	N5733K	μA733CK		
SG733T	S5733K	μA733K		
SG741CN	N5741A	μA741CA		
SG741CT	N5741T	μA741CT		
SG741T	S5741T	μA741T		
SG748CT	N5748T	μA748CT		
SG748T	S5748T	μA748T		
SG14950	N5595F	N5595F		
SG14950	S5595F	S5595F		
SG1496N	N5596F	S5596F		
SG1496T	N5596K	N5596K		
SG1596T	S5596K	S5596K		
SG201N	N5201A	LM201D		
SG201T	N5201T	LM201H		
SG101T	S5101T	LM101H		
SG7520N	N7520B	SN7520N		
SG7521N	N7521B	SN7521N		
SG7522N	N7522B	SN7522N		
SG7523N	N7523B	SN7523N		
SG7524N	N7524B	SN7524N		
SG7525N	N7525B	SN7525N		

# SIGNETICS ■ COMPETITIVE CROSS REFERENCE GUIDE

T I	SIGNETICS DIRECT REPLACEMENT		SIGNETICS FUNCTIONAL EQUIVALENT	
	OLD	NEW	OLD	NEW
SN7522N	N7522B	SN7522N		
SN7523N	N7523B	SN7523N		
SN7524N	N7524B	SN7524N		
SN7525N	N7525B	SN7525N		
SN5512L			S5733K	μA733K
SN7512L			N5733K	μA733CK
SN5514L			S5733K	μA733K
SN7514L			N5733K	μA733CK
SN52810L			S5710T	μA710T
SN72810L			N5710T	μA710CT
SN52510L			S5710T	μA710T
SN72510L			N5710T	μA710CT
SN5510L			S5733K	μA733K
SN52770L			S5740T	μA740T
SN72770L			N5740T	μA740CT
SN52771L			S5740T	μA740T
SN72771L			N5740T	μA740CT
SN72709	N5709A	μA709CA		
SN72709L	N5709T	μA709CT		
SN52709F	S5709G	μA709G		
SN52709L	S5709T	μA709T		
SN72710N	N5710A	μA710CA		
SN72710L	N5710T	μA710CT		
SN52710F	S5710G	μA710G		
SN52710L	S5710T	μA710T		
SN72711N	N5711A	μA711CA		
SN72711L	N5711K	μA711CK		
SN52711L	S5711K	μA711K		
SN72741N	N5741A	μA741CA		
SN72741L	N5741T	μA741CT		
SN72741P	N5741V	μA741CV		
SN72741L	S5741T	μA741T		
SN7520N	N7520B	SN7520N		
SN7521N	N7521B	SN7521N		
SN75450N	N75450A	SN75450N		
SN75450AN	N75450AA	SN75450AN		
SN75451N	N75451A	SN75451N		
SN75451AN	N75451AA	SN75451AN		

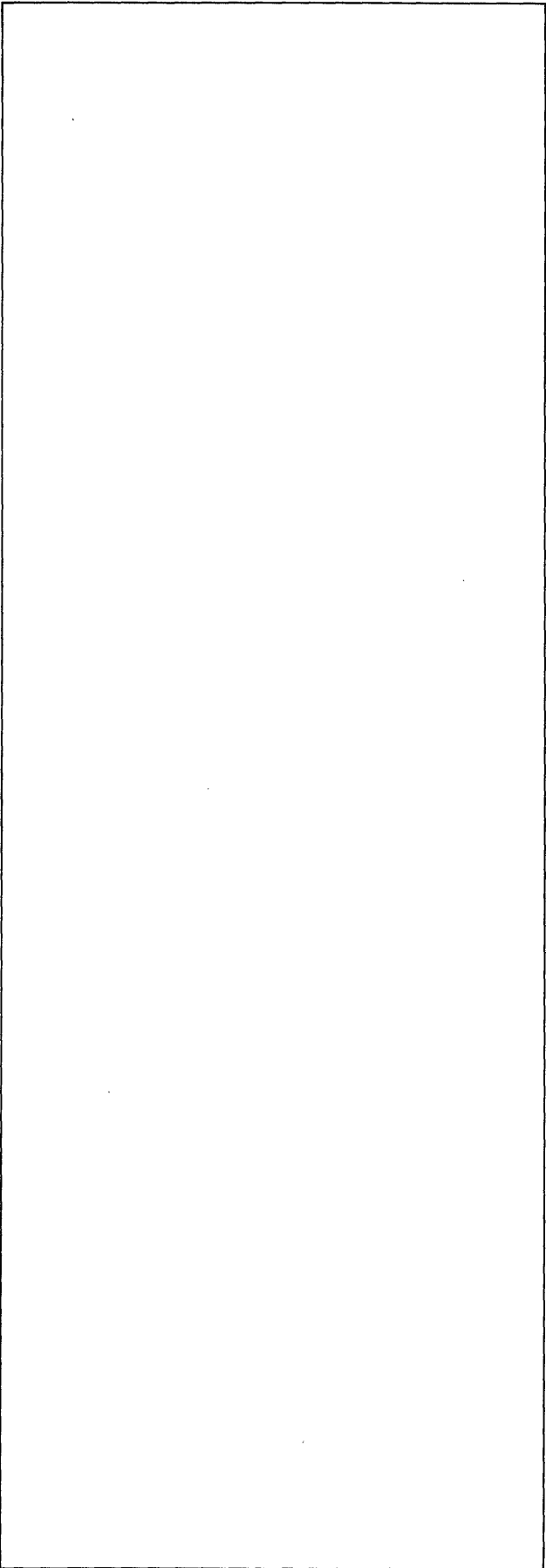

**NOTES:**

1. Signetics provides silicone dip 14 and 16 pin dual inline packages.
2. Cerdip will be available May 1, 1972.

# SECTION 2

## package types





**A PACKAGE**

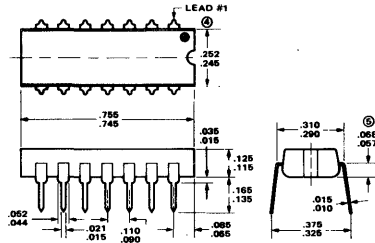

**NOTES:**

1. Lead Material: Alloy 42 or equivalent
2. Body Material: Silicone molded
- ③ Tolerances non-cumulative
- ④ Signetics symbol denotes Lead No. 1
- ⑤ Lead spacing shall be measured within this zone
6. Body dimensions do not include molding flash
7. Thermal resistance:  $\theta_{JA} = .16^{\circ}\text{C/mW}$ ,  $\theta_{JC} = .08^{\circ}\text{C/mW}$

**B PACKAGE**

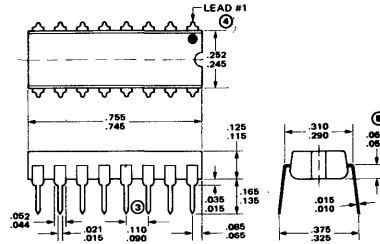

**NOTES:**

1. Lead Material: Alloy 42 or equivalent
2. Body Material: Silicone molded
- ③ Tolerances non-cumulative
- ④ Signetics symbol denotes Lead No. 1
- ⑤ Lead spacing shall be measured within this zone
6. Body dimensions do not include molding flash
7. Thermal resistance:  $\theta_{JA} = .16^{\circ}\text{C/mW}$ ,  $\theta_{JC} = .08^{\circ}\text{C/mW}$

**DB PACKAGE**

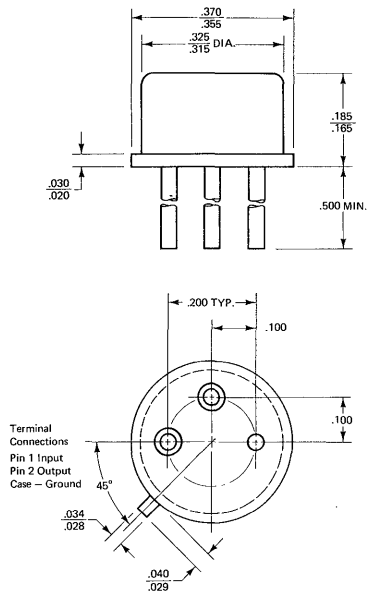

**NOTES:**

1. Lead Material: Kovar Equivalent— Gold Plated
2. Body Material: Eyelet, Kovar or Equivalent— Gold Plated Glass Body
3. Lid Material: Nickel, Weld Seal

**DA PACKAGE**

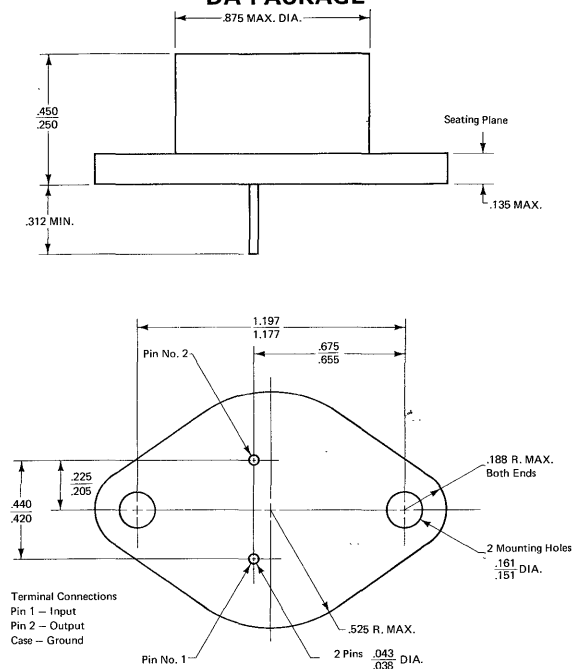

**NOTES:**

1. Lead Material No. 52 Alloy Gold Plated
2. Body Material: 1010 Steel Gold Plated
3. Lid Material: Steel Nickel Plated, Weld Seal

**G PACKAGE**

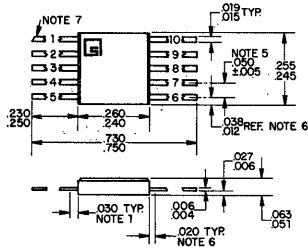

- NOTES:
1. Recommended minimum offset before lead bend.
  2. All leads weldable and solderable.
  3. Thermal resistance:  $\theta_{JA} = 0.3^{\circ}\text{C/mW}$ .
  4. All dimensions in inches.
  5. Tolerances are non-cumulative.
  6. Lead spacing dimensions apply to this area only.
  7. Signetics symbol or angle cut identifies lead No. 1.

**J PACKAGE**

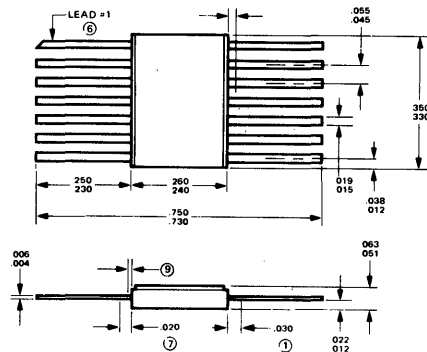

- NOTES:
1. Recommended minimum offset before lead bend
  2. Lead Material: Kovar or equivalent, gold plated
  3. Body Material: Glass
  4. Lid Material: Kovar, oxidized, glass seal
  5. Tolerances non-cumulative
  6. Signetics symbol or angle cut denotes Lead No. 1
  7. Lead spacing shall be measured within this zone
  8. Thermal Resistance:  $\theta_{JA} = .300^{\circ}\text{C/mW}$ ,  $\theta_{JC} = .140^{\circ}\text{C/mW}$
  9. Maximum glass climb: .010

**K PACKAGE**

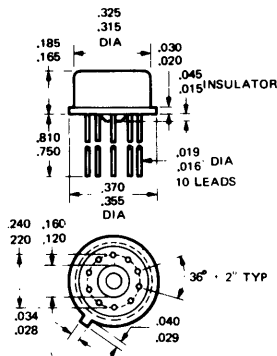

- NOTES:
1. Lead Material: Kovar or Equivalent - Gold Plated
  2. Body Material: Eyelet, Kovar or Equivalent - Gold Plated Glass Body
  3. Lid Material: Nickel, Weld Seal

**R PACKAGE**

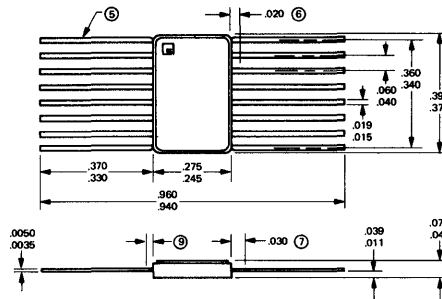

- NOTES:
1. Lead Material: Kovar or equivalent, gold plated
  2. Body Material: Top ring and Base - Kovar or equivalent, gold plated, glass body
  3. Lid Material: Kovar or equivalent, gold plated, alloy seal
  4. Tolerances non-cumulative
  5. Signetics symbol denotes lead No. 1
  6. Lead spacing shall be measured within this zone
  7. Recommended minimum offset before lead bend
  8. Thermal Resistance:  $\theta_{JA} = .155^{\circ}\text{C/mW}$ ,  $\theta_{JC} = .070^{\circ}\text{C/mW}$
  9. Maximum glass climb: .010

T PACKAGE

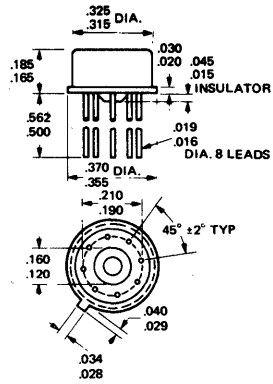

NOTES:

1. Lead Material: Kovar or equivalent - gold plated
2. Body Material: Eyelet, kovar or equivalent - gold plated glass body
3. Lid Material: Nickel, weld seal

V PACKAGE

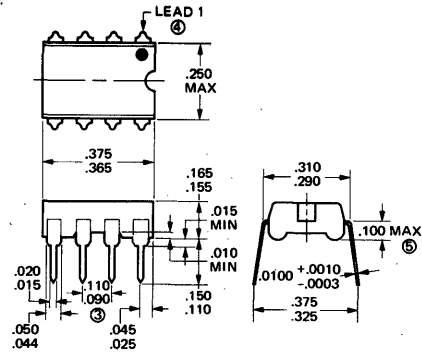

NOTES:

1. Lead Material: Alloy 42 or equivalent, tinned
2. Body Material: Silicone Molded
- ③ Tolerances Non-Cumulative
- ④ Signetics Symbol Denotes Lead =1
- ⑤ Lead Spacing shall be Measured within this Zone
6. Body Dimensions do not Include Molding Flash

**ECL FROM SIGNETICS**

**ECL II SERIES**

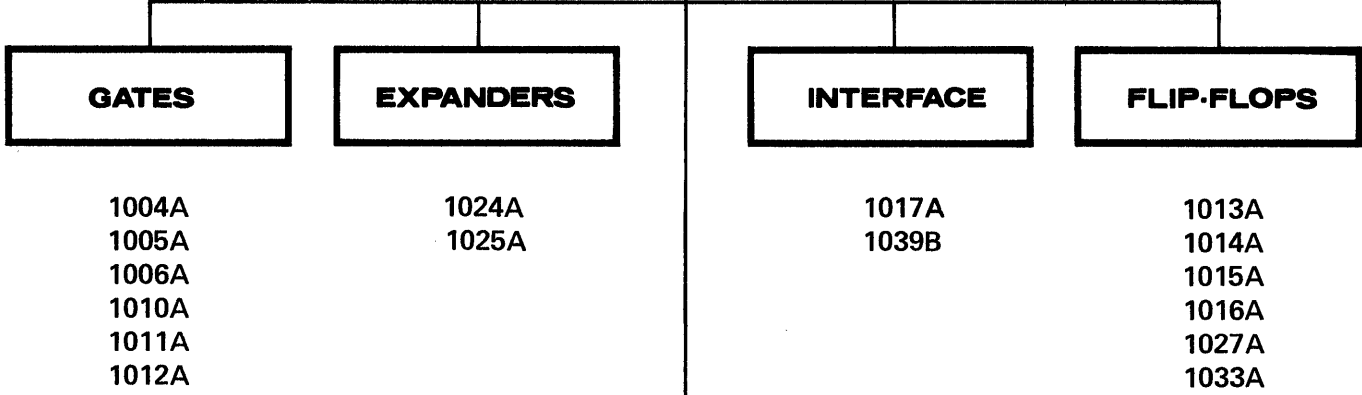

**ECL 10,000 SERIES GATES \***

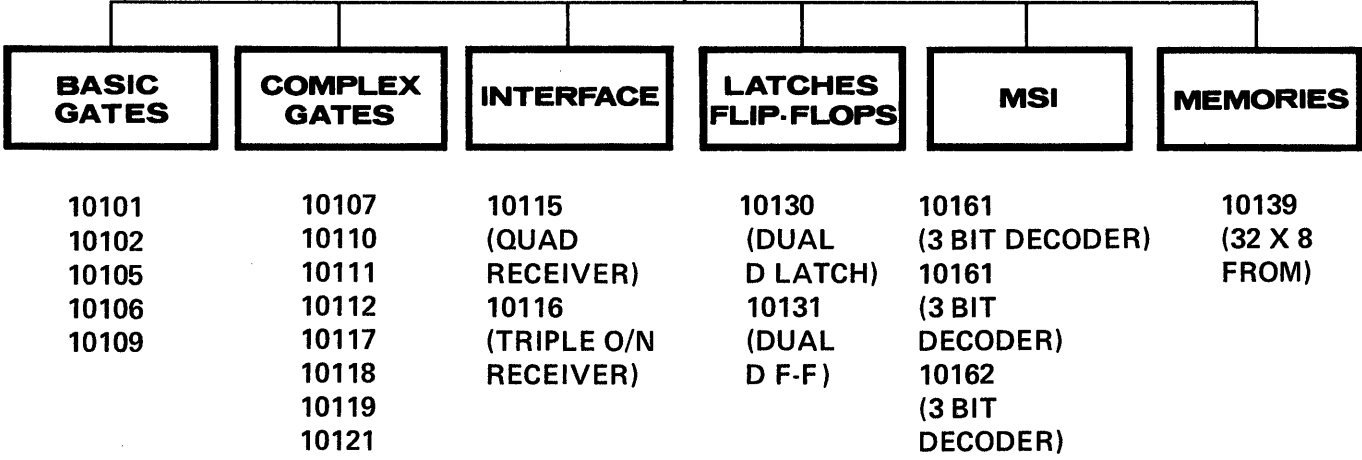

\* TO BE ANNOUNCED

# operational amplifiers **SECTION 3**

10/10/2020

## LINEAR INTEGRATED CIRCUITS

### DESCRIPTION

The 516 is a high gain operational amplifier with differential input and output. Features include large gain-bandwidth product, stable open-loop operation, high output voltage swing under load, high input resistance, wide common mode voltage range and high common mode rejection.

### FEATURES

- OPEN LOOP VOLTAGE GAIN = NE516 15,000  
SE516 18,000
- OPEN LOOP GAIN STABILITY =  $\pm 20\%$
- OUTPUT VOLTAGE SWING = NE516 +10 Volts  
SE516 +11 Volts
- DIFFERENTIAL INPUT RESISTANCE = NE516 100K $\Omega$   
SE516 400K $\Omega$
- INPUT COMMON MODE VOLTAGE RANGE = 23 Volts
- COMMON MODE REJECTION RATIO = 100 db
- INPUT OFFSET CURRENT = NE516 100nA  
SE516 300nA
- OPEN LOOP BANDWIDTH = 300 kHz

### ABSOLUTE MAXIMUM RATINGS

Voltage Applied (Between Pins 1 and 6)	
NE516	34V
SE516	36V
Voltage Applied (Differential)	
	10V
Current Rating (Pins 1, 2, 6 and 10)	
	25mA
Current Rating (Other Pins)	
	10mA
Output Short Circuit Duration (25°C)	
	10sec
Storage Temperature	
	-65°C to +150°C
Operating Temperature	
NE516	0°C to +75°C
SE516	-55°C to +125°C
Junction Temperature	
NE516	150°C
SE516	175°C

### EQUIVALENT CIRCUIT

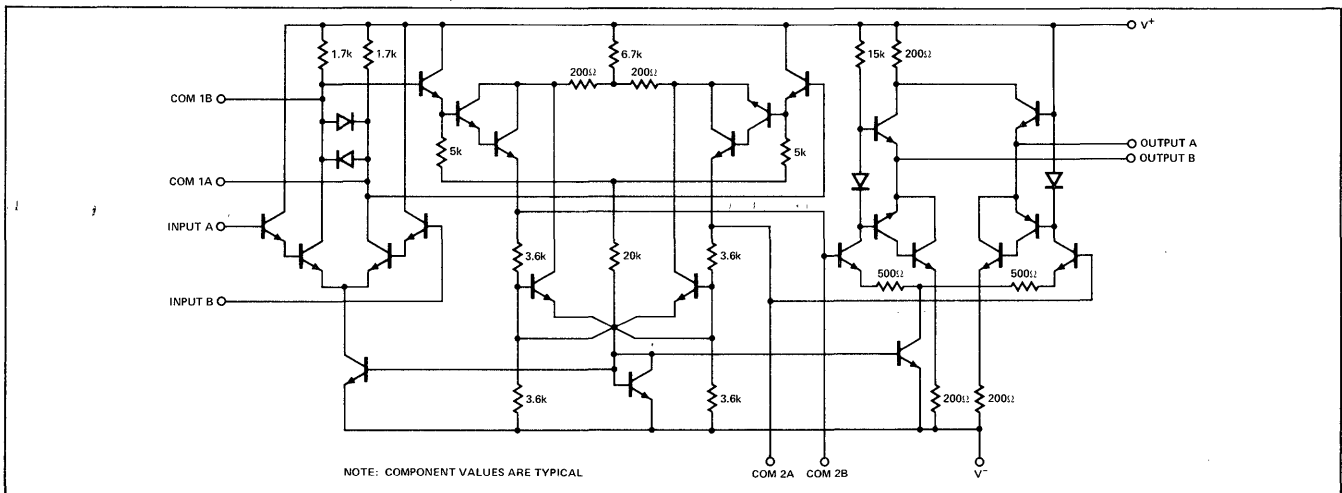

### PIN CONFIGURATION

#### A PACKAGE (Top View)

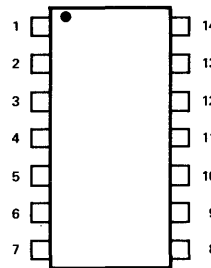

- |                   |                    |
|-------------------|--------------------|
| 1. Input B        | 8. Output A        |
| 2. Com. 1A        | 9. NC              |
| 3. NC             | 10. Com 2A         |
| 4. Com. 2B        | 11. Com. 1B        |
| 5. NC             | 12. NC             |
| 6. Output B       | 13. Input A        |
| 7. V <sup>-</sup> | 14. V <sup>+</sup> |

ORDER PART NOS.  
SE516A/NE516A

#### K PACKAGE

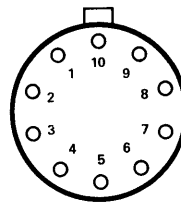

- |                   |                   |
|-------------------|-------------------|
| 1. V <sup>-</sup> | 6. V <sup>+</sup> |
| 2. Output A       | 7. Input B        |
| 3. Com. 2A        | 8. Com. 1A        |
| 4. Com. 1B        | 9. Com. 2B        |
| 5. Input A        | 10. Output B      |

ORDER PART NOS.  
SE516K/NE516K

#### G PACKAGE

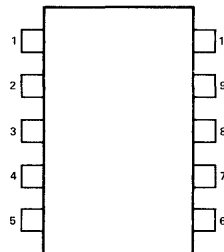

- |                   |                   |
|-------------------|-------------------|
| 1. V <sup>-</sup> | 6. V <sup>+</sup> |
| 2. Output A       | 7. Input B        |
| 3. Com. 2A        | 8. Com. 1A        |
| 4. Com. 1B        | 9. Com. 2B        |
| 5. Input A        | 10. Output B      |

ORDER PART NOS.  
SE516G/NE516G

Maximum ratings are limiting values above which serviceability may be impaired.



**SIGNETICS ■ 516 – OPERATIONAL AMPLIFIER**

**ELECTRICAL CHARACTERISTICS** (Notes: 1, 2, 3, 8) (Standard Conditions:  $V_E = +15V$ ,  $V_K = -15V$ ,  $V_A = 0V$ )

PARAMETERS	TEST CONDITIONS	NE516				SE516				UNITS
		MIN	TYP	MAX	TEMP.	MIN	TYP	MAX	TEMP.	
Open Loop Voltage Gain (DC)	$R_L \geq 2k\Omega$ , Notes 5, 7		16,000		0°C		22,000		-55°C	V/V
		10,000	15,000		+25°C	13,000	18,000		+25°C	V/V
		8,000	13,000		+75°C	10,000	15,000		+125°C	V/V
Open Loop Voltage Gain (AC)	$R_L \geq 2k\Omega$ , $f = 250$ kHz, Note 7	8,000	12,000		+25°C	10,000	15,000		+25°C	V/V
Input Offset Voltage	Note 6		5.0	15	0°C		3.0	10	-55°C	mV
			5.0	15	+25°C		3.0	10	+25°C	mV
			5.0	15	+75°C		3.0	10	+125°C	mV
Input Bias Current	Note 6		1.5	4.5	0°C		0.6	2.0	-55°C	$\mu A$
			1.0	3.0	+25°C		0.3	1.0	+25°C	$\mu A$
			0.6		+75°C		0.15		+125°C	$\mu A$
Input Offset Current	Note 6		0.1	0.6	+25°C		0.06		-55°C	$\mu A$
							0.03	0.2	+25°C	$\mu A$
							0.02		+125°C	$\mu A$
Differential Input Resistance	Notes 4, 6					40	150		-55°C	$k\Omega$
		40	100		+25°C	100	400		+25°C	$k\Omega$
							1,000		+125°C	$k\Omega$
Input Common Mode Range		+8.0	+10		+25°C	+8.0	+10		+25°C	V
		-12	-13			-12	-13			
Power Supply Sensitivity (Referred to Input)			50		+25°C	50			+25°C	$\mu V/V$
			50		+25°C	50			+25°C	$\mu V/V$
Balanced Output dc Level	$R_L \geq 2k\Omega$ , Note 6	-2.5	0	+2.5	+25°C	-2.0	+0.5	+2.5	-55°C	V
Output Voltage Swing	$R_L \geq 2k\Omega$				0°C	-1.5	0	+1.5	+25°C	V
		$\pm 8.0$	$\pm 10$		+25°C	-2.5	-0.5	+2.0	+125°C	V
		$\pm 8.0$	$\pm 10$		+75°C	$\pm 10$	$\pm 11$		+125°C	V
Output Resistance	Note 6		500		+25°C		500		+25°C	$\Omega$
Common Mode Rejection Ratio	Note 6		100		+25°C		100		+25°C	dB
Power Supply Current	Note 6		5.0		0°C		5.0		-55°C	mA
			5.0	6.0	+25°C		5.0	6.0	+25°C	mA
			5.0	6.0	+75°C		5.0	6.0	+125°C	mA

Letter subscripts refer to pins on circuit schematic.

**NOTES:**

1. Voltage and current subscripts refer to pin numbers.
2. All measurements are referenced to an external ground. Positive current flow is defined as into the terminal indicated.
3. All specifications herein apply for interchange of voltages and currents at Pins 5 and 7.
4. Differential Input Resistance is a value computed from input bias current limits.
5. Output voltage swing = 5V peak to peak.
6. Adjust  $V_5$  to obtain  $V_2 = V_{10}$ .
7. Differential input, single ended output.



## LINEAR INTEGRATED CIRCUITS

### DESCRIPTION

The 531 is a fast slewing high performance operational amplifier which retains D.C. performance equal to the best general purpose types while providing far superior large signal A.C. performance. A unique input stage design allows the amplifier to have a large signal response nearly identical to its small signal response. The amplifier can be compensated for truly negligible overshoot with a single capacitor. In applications where fast settling and superior large signal bandwidths are required, the amplifier out performs conventional designs which have much better small signal response. Also, because the small signal response is not extended, no special precautions need be taken with circuit board layout to achieve stability. The high gain, simple compensation and excellent stability of this amplifier allow its use in a wide variety of instrumentation applications.

### FEATURES

- 35V/ $\mu$ sec SLEW RATE AT UNITY GAIN
- PIN FOR PIN REPLACEMENT FOR  $\mu$ A709,  $\mu$ A748 OR LM101
- COMPENSATED WITH A SINGLE CAPACITOR
- SAME LOW DRIFT OFFSET NULL CIRCUITRY AS  $\mu$ A741
- SMALL SIGNAL BANDWIDTH 1 MHz
- LARGE SIGNAL BANDWIDTH 500KHz
- TRUE OP AMP D.C. CHARACTERISTICS MAKE THE 531 THE IDEAL ANSWER TO ALL SLEW RATE LIMITED OPERATIONAL AMPLIFIER APPLICATIONS.

### NOTES:

1. Rating applies for case temperatures to 125°C, derate linearly at 6.5mW/°C for ambient temperatures above +75°C
2. For supply voltages less than  $\pm 15V$ , the absolute maximum input voltage is equal to the supply voltage.
3. Short circuit may be to ground or either supply. Rating applies to +125°C case temperature or +75°C ambient temperature.

### ABSOLUTE MAXIMUM RATINGS

Supply Voltage	$\pm 22V$
Internal Power Dissipation (Note 1)	300mW
Differential Input Voltage	$\pm 15V$
Common Mode Input Voltage (Note 2)	$\pm 15V$
Voltage Between Offset Null and $V^-$	$\pm 0.5V$
Operating Temperature Range	

NE531	0°C to +70°C
SE531	-55°C to +125°C

Storage Temperature Range	-65°C to +150°C
Lead Temperature (Solder, 60 sec.)	300°C
Output Short Circuit Duration (Note 3)	Indefinite

### PIN CONFIGURATION

#### T PACKAGE (Top View)

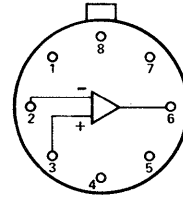

1. Offset Null
2. Inverting Input
3. Noninverting Input
4.  $V^-$
5. Offset Null
6. Output
7.  $V^+$
8. Freq. Comp.

ORDER PART NOS.  
SE531T/NE531T

#### V PACKAGE

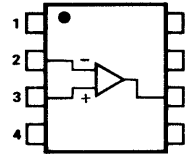

1. Offset Null
2. Inverting Input
3. Noninverting Input
4.  $V^-$
5. Offset Null
6. Output
7.  $V^+$
8. Freq. Comp.

ORDER PART NO. NE531V

### TEST CIRCUITS

#### OFFSET NULL CIRCUIT

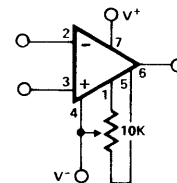

#### TRANSIENT RESPONSE TEST CIRCUIT

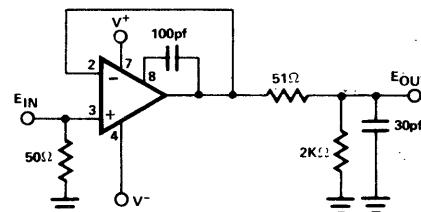

**SIGNETICS ■ 531 – HIGH SLEW RATE OPERATIONAL AMPLIFIER**

**GENERAL ELECTRICAL CHARACTERISTICS ( $V_S = \pm 15V$ ,  $T_A = 25^\circ C$  Unless Otherwise Specified)**

NE531	PARAMETER	CONDITIONS	MIN	TYP	MAX	UNITS
	Input Offset Voltage	$R_S \leq 10K\Omega$		2.0	6	mV
	Input Offset Current			50	200	nA
	Input Bias Current			0.4	1.5	$\mu A$
	Input Resistance			20		M $\Omega$
	Input Voltage Range		$\pm 10$			Volts
	Common Mode Rejection Ratio	$R_S \leq 10K\Omega$	70	100		dB
	Supply Voltage Rejection Ratio	$R_S \leq 10K\Omega$		10	150	$\mu V/V$
	Large Signal Voltage Gain	$R_L \geq 2K\Omega, V_{OUT} = \pm 10V$	20,000	60,000		
	Output Resistance			75		$\Omega$
	Supply Current			5.5	10	mA
	Power Consumption			165	300	mW
	Full Power Bandwidth			500		KHz
	Settling Time, 1%	$A_V = +1, V_{IN} = \pm 10V$		1.5		$\mu sec$
	Settling Time, .01%	$A_V = +1, V_{IN} = \pm 10V$		2.5		$\mu sec$
	Large Signal Overshoot	$A_V = +1, V_{IN} = \pm 10V$		2		%
	Small Signal Overshoot	$A_V = +1, V_{IN} = 400mV$		5		%
	Small Signal Risetime	$A_V = +1, V_{IN} = 400mV$		300		nsec
	The Following Apply for $0^\circ C \leq T_A \leq +70^\circ C$ :					
	Input Offset Voltage	$R_S \leq 10K\Omega$			7.5	mV
	Input Offset Current	$T_A = +70^\circ C$			200	nA
		$T_A = 0^\circ C$			300	nA
	Input Bias Current	$T_A = +70^\circ C$			1.5	$\mu A$
		$T_A = 0^\circ C$			2.0	$\mu A$
	Large Signal Voltage Gain	$R_L \geq 2K\Omega, V_{OUT} = \pm 10V$	15,000			
	Output Voltage Swing	$R_L \geq 2K\Omega$	$\pm 10$	$\pm 13$		Volts
	Slew Rate	$A_V = 100$		35		V/ $\mu s$
		$A_V = 10$		35		V/ $\mu s$
		$A_V = 1$ (non-inverting)		30		V/ $\mu s$
		$A_V = 1$ (inverting)		35		V/ $\mu s$
	Supply Current	$T_A = +70^\circ C$		4.5	5.5	mA

SE531	PARAMETER	CONDITIONS	MIN	TYP	MAX	UNITS
	Input Offset Voltage	$R_S \leq 10K\Omega$		2.0	5.0	mV
	Input Offset Current			30	200	nA
	Input Bias Current			300	500	nA
	Input Resistance			20		M $\Omega$
	Input Voltage Range		$\pm 10$			Volts
	Large Signal Voltage Gain	$R_L \geq 2K\Omega, V_{OUT} = \pm 10V$	50,000	100,000		
	Output Resistance			75		$\Omega$
	Supply Current			5.5	7.0	mA
	Power Consumption			165	210	mW
	Full Power Bandwidth			500		KHz
	Settling Time, 1%	$A_V = +1, V_{IN} = \pm 10V$		1.5		$\mu sec$
	Settling Time, .01%	$A_V = +1, V_{IN} = \pm 10V$		2.5		$\mu sec$
	Large Signal Overshoot	$A_V = +1, V_{IN} = \pm 10V$		2		%
	Small Signal Risetime	$A_V = +1, V_{IN} = 400mV$		300		nsec
	Small Signal Overshoot	$A_V = +1, V_{IN} = 400mV$		5		%
	Slew Rate	$A_V = 100$		35		V/ $\mu s$
		$A_V = 10$		35		V/ $\mu s$
		$A_V = 1$ (non-inverting)		30		V/ $\mu s$
		$A_V = 1$ (inverting)		35		V/ $\mu s$
	The following apply for $-55^\circ C \leq T_A \leq +125^\circ C$ :					
	Input Offset Voltage	$R_S \leq 10K\Omega$			6	mV
	Input Offset Current	$T_A = +125^\circ C$			200	nA
		$T_A = -55^\circ C$			500	nA
	Input Bias Current	$T_A = +125^\circ C$			500	nA
		$T_A = -55^\circ C$			1.5	$\mu A$
	Common Mode Rejection Ratio	$R_S \leq 10K\Omega$	70	90		dB
	Supply Voltage Rejection Ratio	$R_S \leq 10K\Omega$		10	150	$\mu V/V$
	Large Signal Voltage Gain	$R_L \geq 2K\Omega, V_{OUT} = \pm 10V$	25,000			
	Output Voltage Swing	$R_L \geq 2K\Omega$	$\pm 10$	$\pm 13$		V
	Supply Current	$T_A = +125^\circ C$		4.5	5.5	mA

**NOTES:**

All AC parametric testing is performed using the conditions of the transient response test circuit, page 1.

TYPICAL PERFORMANCE CHARACTERISTICS ( $V_S = \pm 15V$ ,  $T_A = +25^\circ C$  unless otherwise noted)

**INPUT OFFSET CURRENT AS A FUNCTION OF AMBIENT TEMPERATURE**

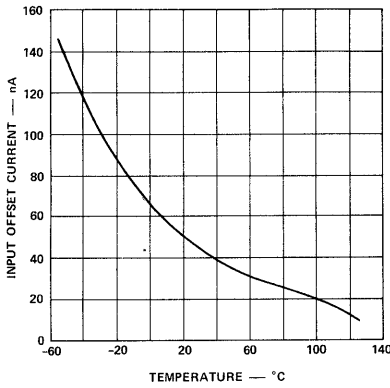

**INPUT BIAS CURRENT AS A FUNCTION OF AMBIENT TEMPERATURE**

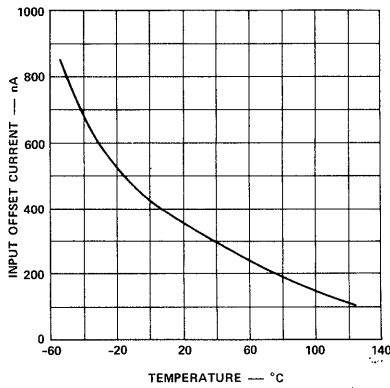

**INPUT BIAS CURRENT AS A FUNCTION OF SUPPLY VOLTAGE**

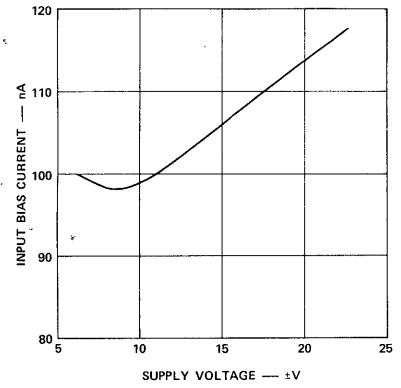

**POWER CONSUMPTION AS A FUNCTION OF SUPPLY VOLTAGE**

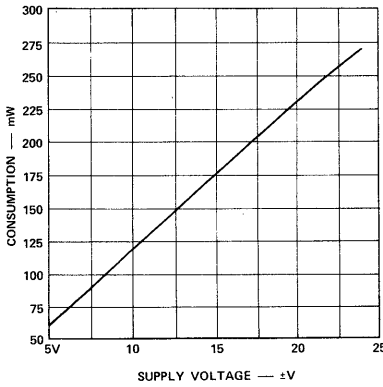

**POWER CONSUMPTION AS A FUNCTION OF AMBIENT TEMPERATURE**

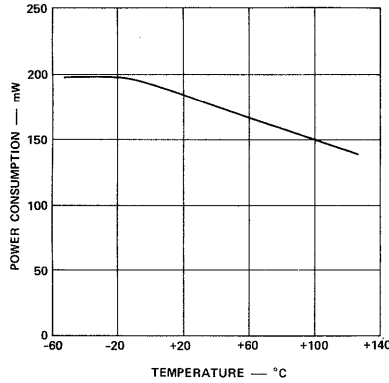

**OPEN LOOP VOLTAGE GAIN AS A FUNCTION OF SUPPLY VOLTAGE**

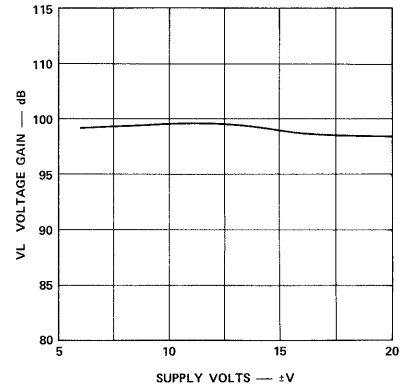

**OUTPUT VOLTAGE SWING AS A FUNCTION OF SUPPLY VOLTAGE**

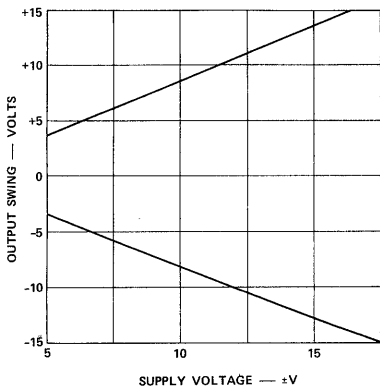

**INPUT VOLTAGE RANGE AS A FUNCTION OF SUPPLY VOLTAGE**

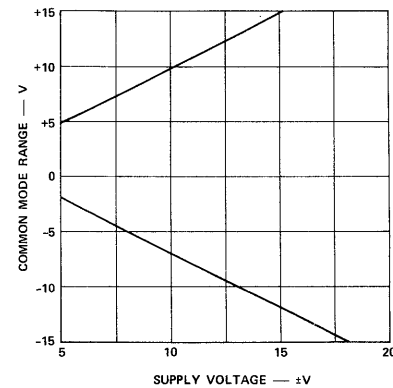

**OUTPUT VOLTAGE SWING AS A FUNCTION OF FREQUENCY**

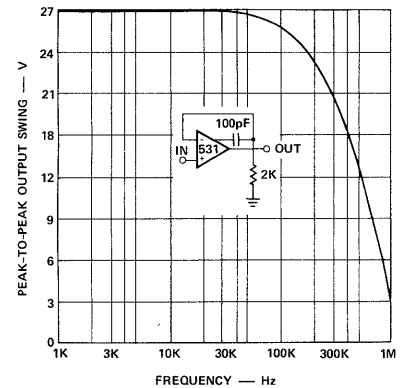

TYPICAL CHARACTERISTIC CURVES (Cont'd.)

VOLTAGE FOLLOWER  
LARGE SIGNAL RESPONSE

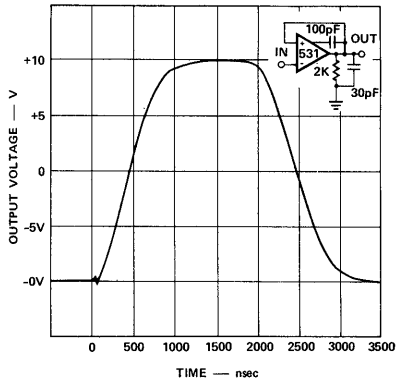

VOLTAGE FOLLOWER  
TRANSIENT RESPONSE

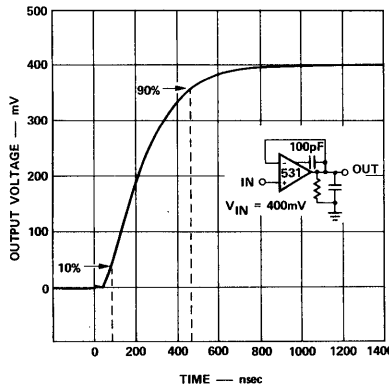

UNITY GAIN  
INVERTING AMPLIFIER  
LARGE SIGNAL RESPONSE

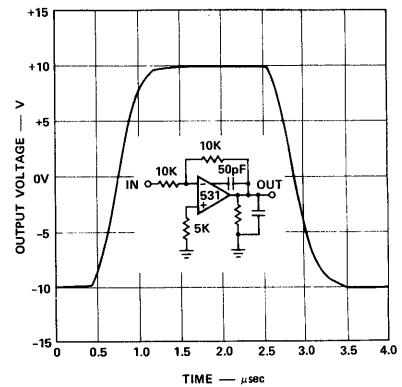

CLOSED LOOP NON-INVERTING VOLTAGE  
GAIN AS A FUNCTION OF FREQUENCY

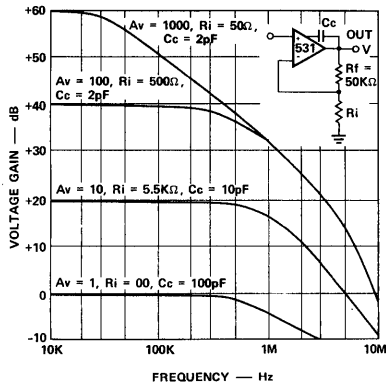

OPEN LOOP PHASE RESPONSE AND VOLTAGE  
GAIN AS A FUNCTION OF FREQUENCY

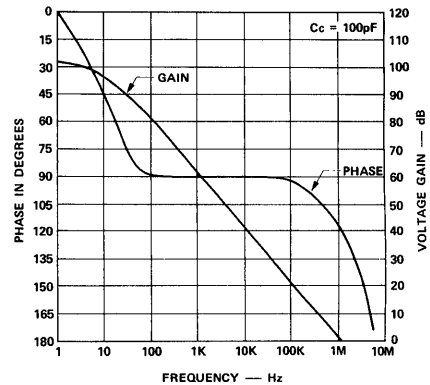

TYPICAL APPLICATIONS

3 POLE ACTIVE LOW PASS FILTER BUTTERWORTH MAXIMALLY FLAT RESPONSE\*

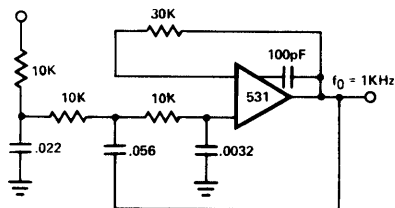

RESPONSE OF 3-POLE ACTIVE  
BUTTERWORTH  
MAXIMALLY FLAT FILTER

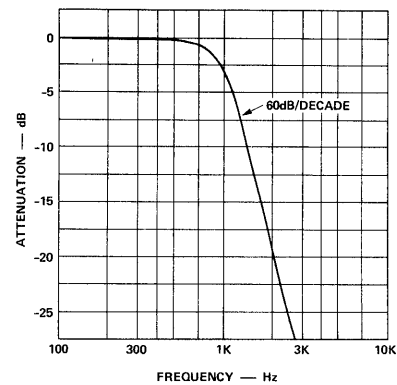

\* Reference — EDN Dec. 15, 1970  
Simplify 3-Pole Active Filter Design  
A. Paul Brokow

TYPICAL APPLICATIONS (Cont'd.)

**HIGH SPEED INVERTER (10MHz Bandwidth)**

**PULSE RESPONSE  
HIGH SPEED INVERTER**

0.5V/DIV.  
200nsec/DIV

**FAST SETTLING VOLTAGE FOLLOWER**

**LARGE SIGNAL RESPONSE  
VOLTAGE FOLLOWER**

2V/DIV  
0.5µs/DIV    f = 500KHz

**PRECISION RECTIFIERS**

(a) HALF WAVE

(b) FULL WAVE

TYPICAL APPLICATIONS (Cont'd.)

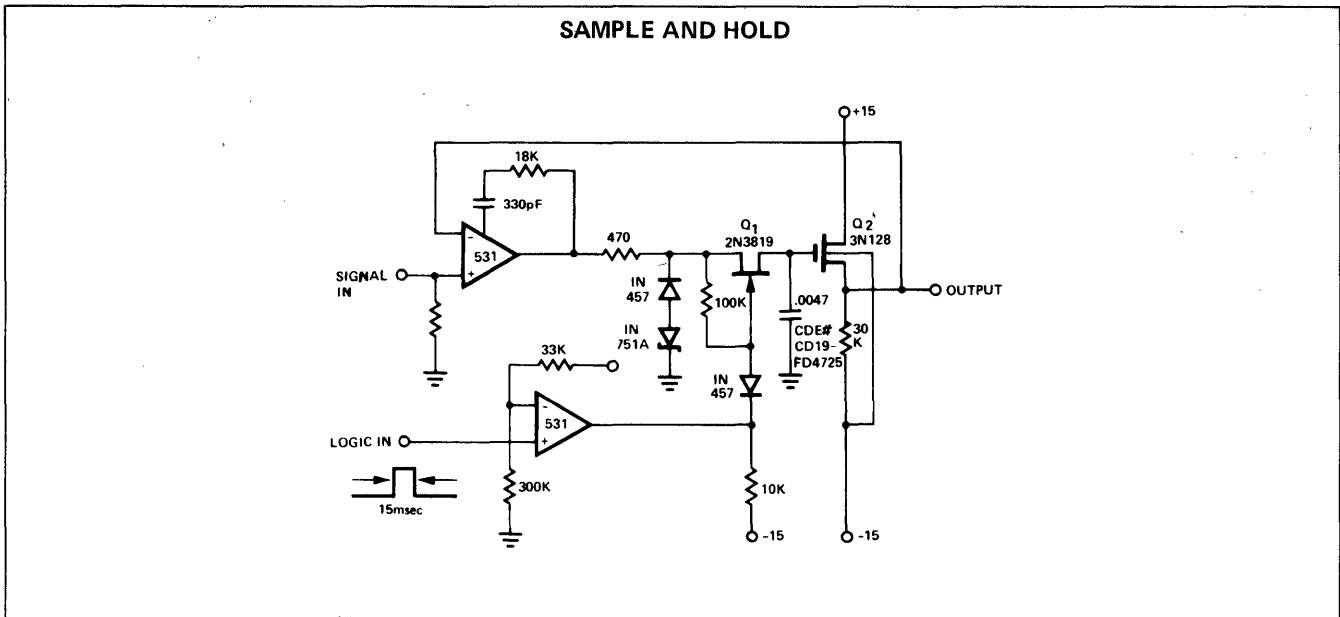
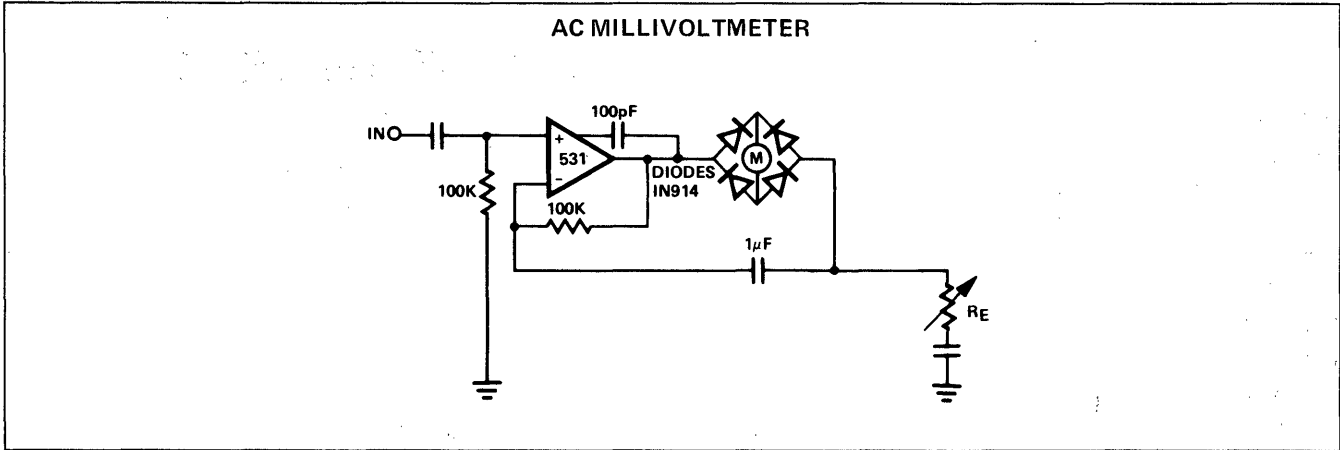

## LINEAR INTEGRATED CIRCUITS

### DESCRIPTION

The 533 is a high performance operational amplifier specifically designed for applications requiring low power consumption or reduced supply voltage. The 533 features single capacitor compensation, input and output protection and is pin compatible with the  $\mu A709$ ,  $\mu A748$ , and LM101.

### FEATURES

- LESS THAN 100 $\mu$ W POWER DISSIPATION
- LOW INPUT OFFSET VOLTAGE
- LOW INPUT BIAS AND OFFSET CURRENTS
- HIGH COMMON MODE AND POWER SUPPLY REJECTION RATIOS
- EXCELLENT TEMPERATURE STABILITY
- NO LATCH UP

### ABSOLUTE MAXIMUM RATINGS

Supply Voltage		$\pm 18V$
Differential Input Voltage		$\pm 5V$
Input Voltage		$\pm V_S$
Operating Temperature Range	SE533	$-55^\circ C$ to $+125^\circ C$
	NE533	$0^\circ C$ to $70^\circ C$
Lead Temperature (Solder, 60 sec)		$300^\circ C$
Output Short Circuit Duration (Note 1)		Indefinite

1. Short circuit may be to ground or either supply. Rating applies to  $+125^\circ C$  case temperature or  $+75^\circ C$  ambient temperature.

### PULSE RESPONSE TEST CIRCUIT

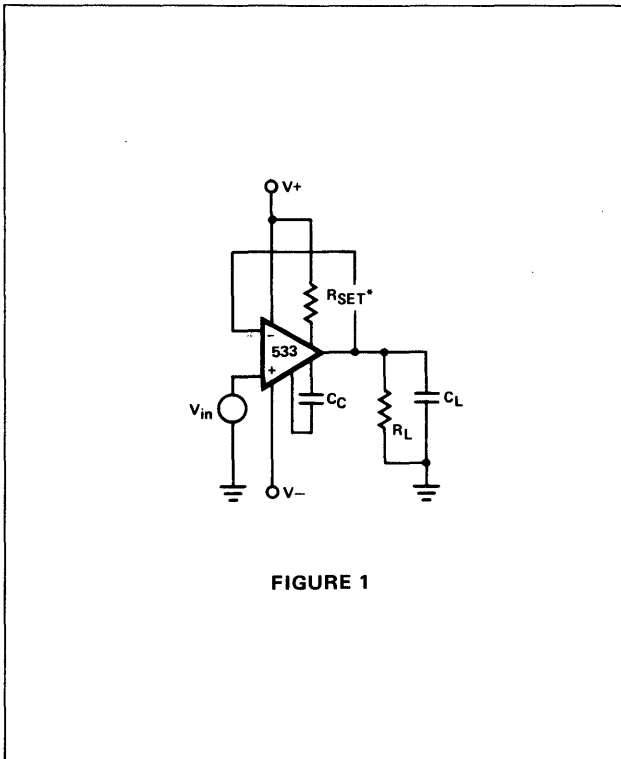
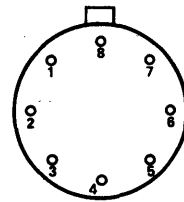

FIGURE 1

### PIN CONFIGURATION

#### T PACKAGE (Top View)



1. Compensation
2. Inverting Input
3. Noninverting Input
4.  $V^-$
5. Compensation
6. Output
7.  $V^+$
8.  $R_{SET}$

ORDER PART NOS.  
SE533T/NE533T

#### V PACKAGE (Top View)

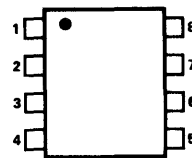

1. Compensation
2. Inverting Input
3. Noninverting Input
4.  $V^-$
5. Compensation
6. Output
7.  $V^+$
8.  $R_{SET}$

ORDER PART NOS.  
SE533V/NE533V

#### NOTE:

$R_{SET}$  establishes internal biasing of the amplifier to allow for a wide range of supply voltages. Recommended values of  $R_{SET}$  are  $3.9m\Omega$  at  $V_S = \pm 3V$  or  $15m\Omega$  at  $V_S = \pm 15V$ . Consult graphs for intermediate values.



ELECTRICAL CHARACTERISTICS (NOTE 1)

PARAMETER	CONDITIONS	NE533			SE533			UNITS
		MIN.	TYP.	MAX.	MIN.	TYP.	MAX.	
Input Offset Voltage	$V_S = \pm 3V$ , and $\pm 15V$ , $R_S = 100K\Omega$			3			2	mV
Input Offset Voltage	$V_S = \pm 3V$ , and $\pm 15V$ , $R_S = 100K\Omega$ , $T_A = 25^\circ C$		1	2		0.5	1	mV
Input Bias Current	$V_S = \pm 3V$ , and $\pm 15V$			30			30	nA
Input Bias Current	$V_S = \pm 3V$ , and $\pm 15V$ , $T_A = 25^\circ C$		5	10		2	10	nA
Input Offset Current	$V_S = \pm 3V$ , and $\pm 15V$			10			10	nA
Input Offset Current	$V_S = \pm 3V$ , and $\pm 15V$ , $T_A = 25^\circ C$		1	5		0.5	5	nA
Input Resistance	$V_S = \pm 3V$ , and $\pm 15V$	15			15			$m\Omega$
Input Resistance	$V_S = \pm 3V$ , and $\pm 15V$ , $T_A = 25^\circ C$	30	60		30	60		$m\Omega$
Input Voltage Range	$V_S = \pm 3V$	$\pm 1.50$			$\pm 1.50$			V
Input Voltage Range	$V_S = \pm 15V$	$\pm 10$			$\pm 10$			V
Large Signal Voltage Gain	$V_S = \pm 3V$ , $R_L \geq 20k\Omega$ , $V_{out} = \pm 1.0V$	10			10			V/mV
Large Signal Voltage Gain	$V_S = \pm 3V$ , $R_L \geq 20k\Omega$ , $V_{out} = \pm 1.0V$ , $T_A = 25^\circ C$	12	15		16	20		V/mV
Large Signal Voltage Gain	$V_S = \pm 15V$ , $R_L \geq 50k\Omega$ , $V_{out} = \pm 10V$	25			25			V/mV
Large Signal Voltage Gain	$V_S = \pm 15V$ , $R_L \geq 50k\Omega$ , $V_{out} = \pm 10V$ , $T_A = 25^\circ C$	40	60		50	70		V/mV
Output Short Circuit Current	$V_S = \pm 3V$ , $\pm 15V$ , $T_A = 25^\circ C$		6			6		mA
Common Mode Rejection Ratio	$V_S = \pm 3V$ , $R_S \leq 100k\Omega$	74			80			dB
Common Mode Rejection Ratio	$V_S = \pm 3V$ , $R_S \leq 100k\Omega$ , $T_A = 25^\circ C$	84	105		90	100		dB
Common Mode Rejection Ratio	$V_S = \pm 15V$ , $R_S \leq 100k\Omega$	84			80			dB
Common Mode Rejection Ratio	$V_S = \pm 15V$ , $R_S \leq 100k\Omega$ , $T_A = 25^\circ C$	90	110		100	120		dB
Power Supply Rejection Ratio	$V_S = \pm 3V$ to $\pm 15V$ , $R_S \leq 100k\Omega$			100			50	$\mu V/V$
Power Supply Rejection Ratio	$V_S = \pm 3V$ to $\pm 15V$ , $R_S \leq 100k\Omega$ , $T_A = 25^\circ C$		20	50		10	25	$\mu V/V$
Supply Current	$V_S = \pm 3V$ $V_0 = 0V$			20			16	$\mu A$
Supply Current	$V_S = \pm 15V$ $V_0 = 0V$			50			30	$\mu A$
Power Dissipation	$V_S = \pm 3V$ $V_0 = 0V$			120			96	$\mu W$
Power Dissipation	$V_S = \pm 15V$ $V_0 = 0V$			1.5			0.9	mW

TRANSIENT RESPONSE (See Figure 1)

Rise Time	$V_S = \pm 3V$ , $R_L = 20k$ , $C_L = 100pF$		2			2		$\mu sec$
Overshoot	$V_{in} = 10mV$ , $C_C = 0.05\mu f$		10			10		%
Slew Rate	$T_A = 25^\circ C$		5			5		$mV/\mu sec$
Rise Time	$V_S = \pm 15V$ , $R_L = 50k$ , $C_C = 100pF$		1			1		$\mu sec$
Overshoot	$V_{in} = 20V$ , $C_C = 0.05\mu f$		10			10		%
Slew Rate	$T_A = 25^\circ C$		30			30		$mV/\mu sec$

NOTE 1: Specifications apply for the full temperature range unless otherwise stated. For  $V_S = \pm 3V$ ,  $R_{set} = 3.9m\Omega$ ; for  $V_S = \pm 15V$ ,  $R_{set} = 15m\Omega$

TYPICAL CHARACTERISTIC CURVES

INPUT BIAS AND OFFSET CURRENTS AS FUNCTIONS OF AMBIENT TEMPERATURE

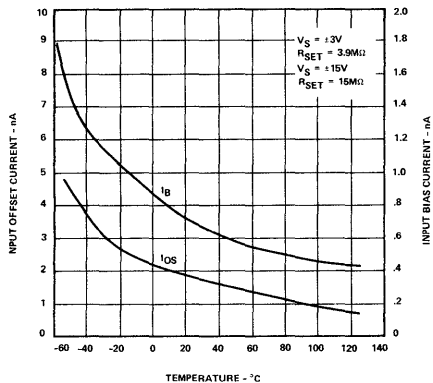

VOLTAGE GAIN AS A FUNCTION OF FREQUENCY

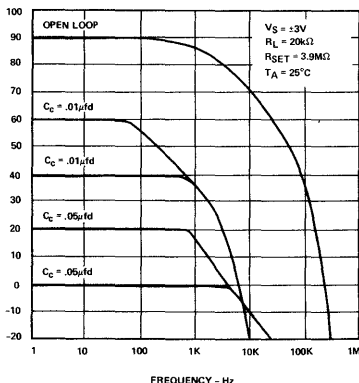

LARGE SIGNAL OPEN LOOP VOLTAGE GAIN AS A FUNCTION OF AMBIENT TEMPERATURE

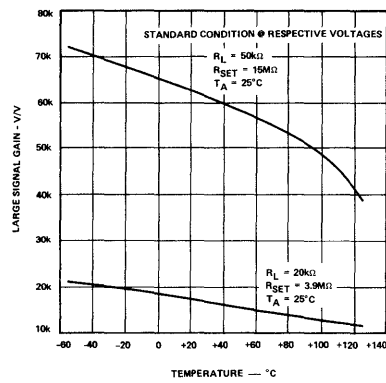

VOLTAGE GAIN AS A FUNCTION OF FREQUENCY

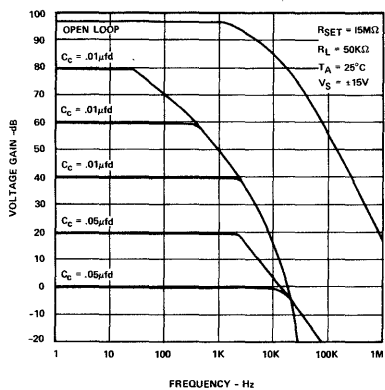

OUTPUT VOLTAGE SWING AS A FUNCTION OF FREQUENCY

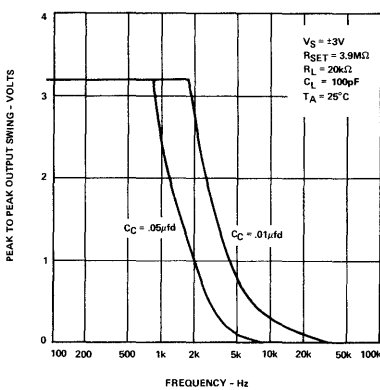

OUTPUT VOLTAGE SWING AS A FUNCTION OF FREQUENCY

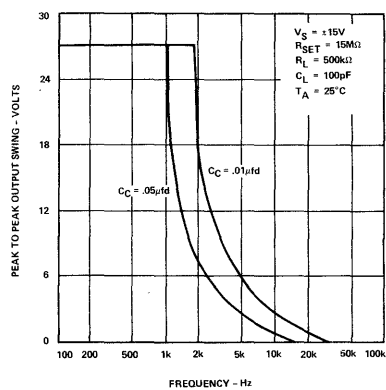

POWER CONSUMPTION AS A FUNCTION OF AMBIENT TEMPERATURE

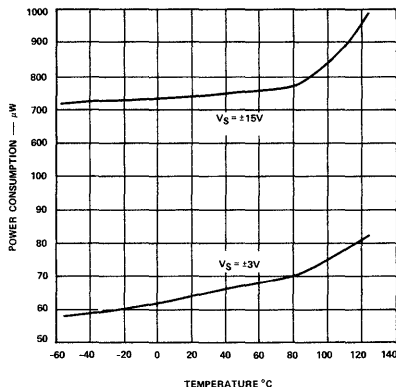

SMALL SIGNAL UNITY GAIN TRANSIENT RESPONSE

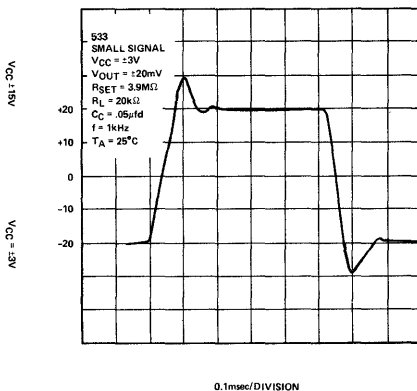

SMALL SIGNAL UNITY GAIN TRANSIENT RESPONSE

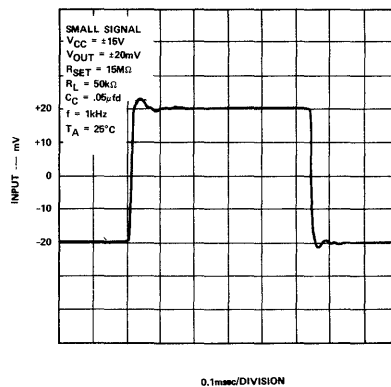

TYPICAL CHARACTERISTIC CURVES (Cont'd.)

OUTPUT VOLTAGE SWING AS A FUNCTION OF SUPPLY VOLTAGE

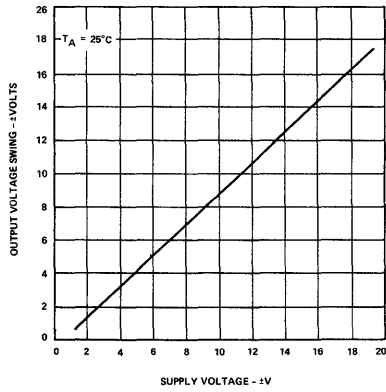

UNITY GAIN VOLTAGE FOLLOWER LARGE SIGNAL RESPONSE

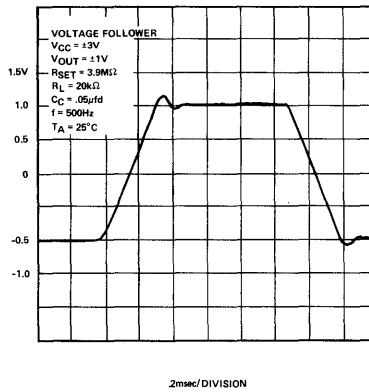

UNITY GAIN VOLTAGE FOLLOWER LARGE SIGNAL RESPONSE

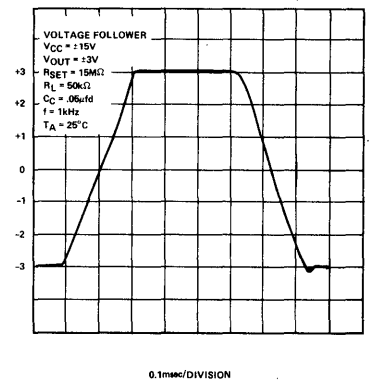

TYPICAL APPLICATIONS

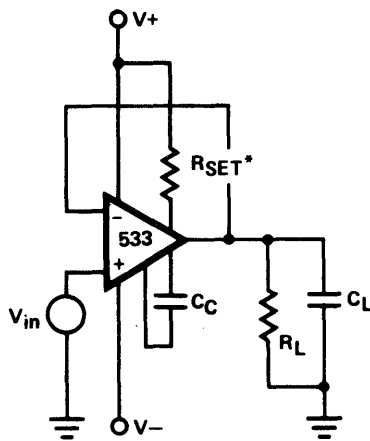

RECOMMENDED VALUES OF RSET FOR INTERMEDIATE SUPPLY VOLTAGES

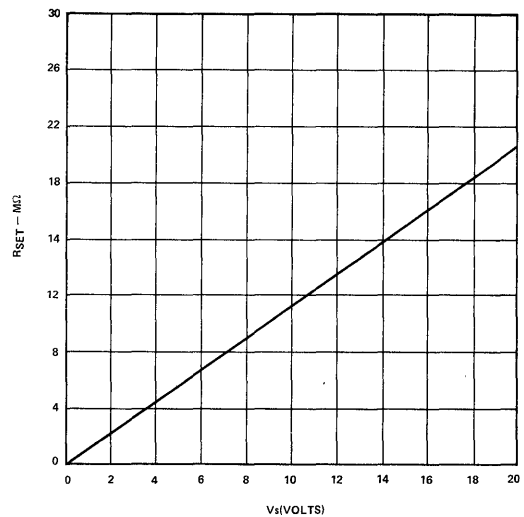

### DESCRIPTION

The 536 is a special purpose high performance operational amplifier utilizing a FET input stage for extremely high input impedance and low input current.

The device features internal compensation, standard pinout, wide differential and common mode input voltage range, high slew rate and high output drive capability.

### FEATURES

- 5pA INPUT BIAS CURRENT
- INPUT AND OUTPUT PROTECTION
- OFFSET NULL CAPABILITY
- INTERNALLY COMPENSATED
- 6V/ $\mu$ sec SLEW RATE
- STANDARD PINOUT
- 1 MHz UNITY GAIN BANDWIDTH

### ABSOLUTE MAXIMUM RATING

Supply Voltage	$\pm 22V$
Differential Input Voltage Range	$\pm 30V$
Common Mode Input Voltage Range	$\pm V_s$
Power Dissipation (Note 1)	500mW
Operating Temperature Range	SU536T $-55^\circ C$ to $+85^\circ C$ NE536T $0^\circ C$ to $+70^\circ C$
Storage Temperature Range	$-65^\circ C$ to $+150^\circ C$
Lead Temperature (Solder, 60 sec)	$300^\circ C$
Output Short Circuit Duration (Note 2)	Indefinite

### NOTES:

1. Rating applies for case temperatures to  $+25^\circ C$ ; derate linearly at  $6.5mW/^\circ C$  for ambient temperatures above  $75^\circ C$ .
2. Short circuit may be to ground or either supply. Rating applies to  $+125^\circ C$  case temperature or  $+75^\circ C$  ambient temperature.

### EQUIVALENT CIRCUIT

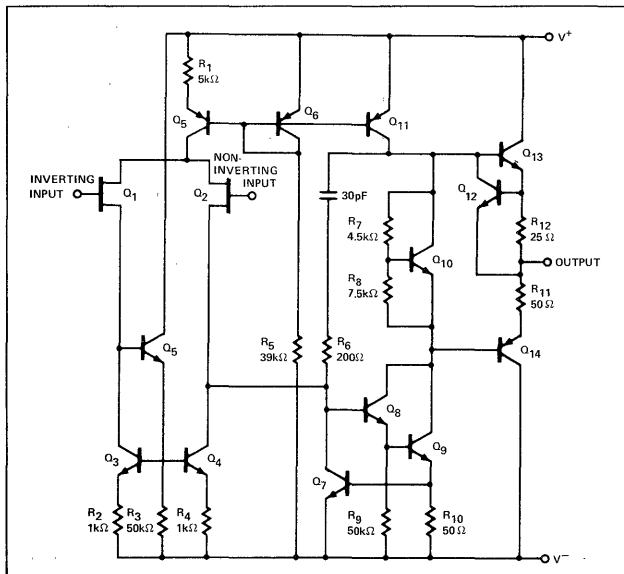

### LINEAR INTEGRATED CIRCUITS

#### PIN CONFIGURATION

T PACKAGE  
(Top View)

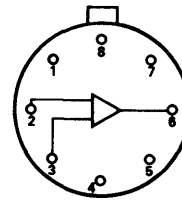

1. Offset Null
2. Inverting Input
3. Non-inverting Input
4.  $V^-$
5. Offset Null
6. Output
7.  $V^+$
8. NC

ORDER PART NOS. SE536T/NE536T

#### TEST CIRCUITS

##### VOLTAGE FOLLOWER CIRCUIT

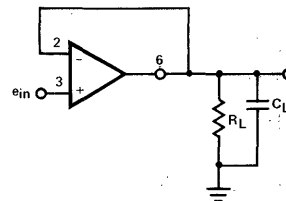

##### OFFSET NULL CIRCUIT

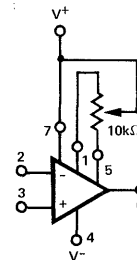

**SIGNETICS ■ SU536/NE536 – FET OPERATIONAL AMPLIFIER**

**ELECTRICAL CHARACTERISTICS** (SU536:  $\pm 6V \leq V_S \leq \pm 20V$ ; NE536:  $V_S = \pm 15V$  unless otherwise noted.)

PARAMETER	TEST CONDITIONS	SU536			NE536			UNITS
		MIN	TYP	MAX	MIN	TYP	MAX	
INPUT CHARACTERISTICS Large Signal Voltage Gain @ +25°C Over Temperature Range	$V_S = \pm 15V, V_{OUT} = \pm 10V$ $R_L \geq 2k\Omega$	50	100		50	100		V/mV
		50	100		25	100		V/mV
Input Offset Voltage @ +25°C Over Temperature Range vs Temperature (drift) vs Common Mode Voltage (C.M.R.R.) vs Power Supply (P.S.R.R.)	$V_{IN} = \pm 10V, R_S \leq 10k\Omega$ Note 1, $R_S \leq 10k\Omega$	7.5	20		30	90		mV
		7.5	30		30			mV
		20			30			$\mu V/^\circ C$
		70	80		64	80		dB
Input Current @ +25°C Over Temperature Range vs Temperature (drift)	Either Input		5	30		30	100	$\mu A$
			250	3000				$\mu A$
		Typ. Doubles Every 10°C						
Input Offset Current @ +25°C Over Temperature (drift)			5			5		$\mu A$
Input Impedance Differential Resistance Differential Capacitance	$T_A = +25^\circ C$		$10^{14}$			$10^{14}$		$\Omega$
	$T_A = +25^\circ C$		6			6		pF
Input Noise (0.1Hz – 100kHz) Voltage Noise			20			20		$\mu V_{rms}$
Common Mode Voltage Range	$V_S = \pm 15V$	$\pm 10$	$\pm 11$		$\pm 10$	$\pm 11$		V
OUTPUT CHARACTERISTICS								
Output Current	$V_S = \pm 15V$	5			5			mA
Open Loop Output Impedance			100			100		$\Omega$
Output Voltage Swing	$V_S = \pm 15V, R_L \geq 2k\Omega$	$\pm 10$	$\pm 12$		$\pm 10$	$\pm 10$		V
	$V_S = \pm 15V, R_L \geq 10k\Omega$	$\pm 12$	$\pm 13$		$\pm 12$	$\pm 13$		V
Short Circuit Current	$V_S = \pm 15V, T_A = +25^\circ C$		17			17		mA
FREQUENCY AND TRANSIENT RESPONSE								
Gain Bandwidth Product	$V_S = \pm 15V, T_A = +25^\circ C,$ $A = 100$		1			1		MHz
Unity Gain Frequency	$V_S = \pm 15V, T_A = +25^\circ C$		1			1		MHz
Full Power Bandwidth	$V_S = \pm 15V, T_A = +25^\circ V$		100			100		kHz
Slew Rate	$V_S = \pm 15V, T_A = +25^\circ C, A = -1$ $V_S = \pm 15V, T_A = +25^\circ C, A = +1$		6			6		V/ $\mu s$
			6			6		V/ $\mu s$
POWER SUPPLY REQUIREMENT								
Power Supply Range		$\pm 6$		$\pm 20$	$\pm 6$		$\pm 18$	V
Quiescent Supply Current	$V_S = \pm 20V, V_{OUT} = 0V,$ $T_A = +25^\circ C$		4.5	5.5				mA
	$V_S = \pm 15V, V_{OUT} = 0V,$ $T_A = +25^\circ C$					6.0	8.0	mA
Quiescent Power Dissipation	$V_S = \pm 15V, V_{OUT} = 0V,$ $T_A = +25^\circ C$		180			180		mW

Parameters are tested over temperature range unless otherwise noted.

NOTE 1: SU536:  $V_S = \pm 6V$  to  $\pm 20V$   
NE536:  $V_S = \pm 6V$  to  $\pm 15V$

TYPICAL CHARACTERISTIC CURVES

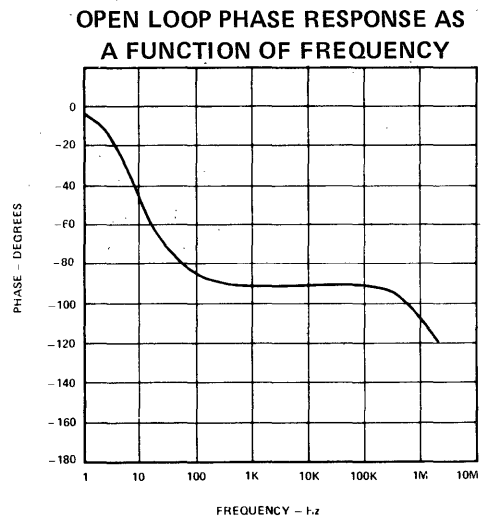
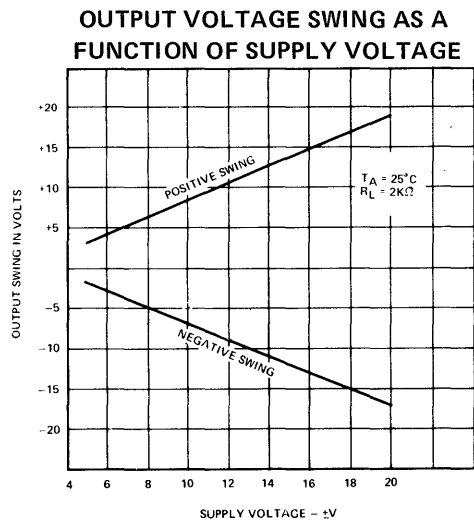
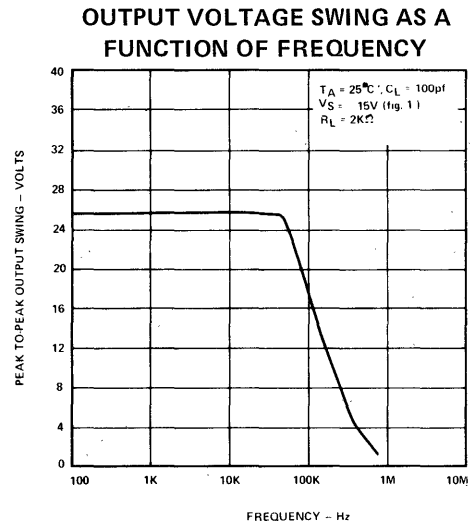
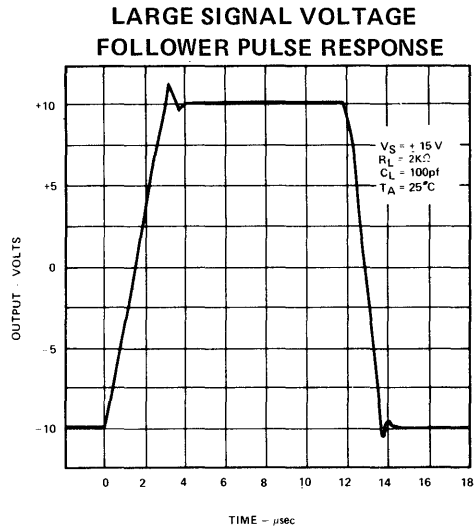
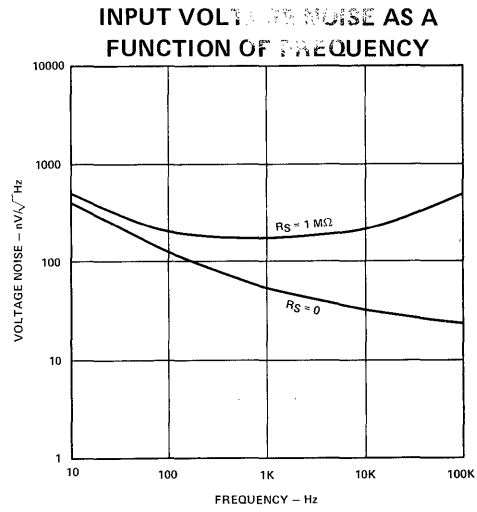
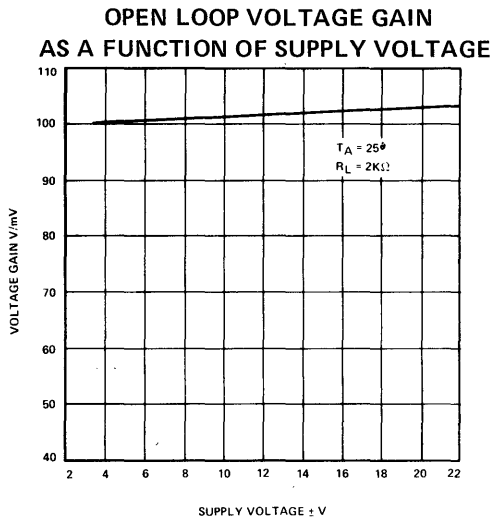

TYPICAL CHARACTERISTIC CURVES (Cont'd.)

OPEN LOOP VOLTAGE GAIN AS A FUNCTION OF SUPPLY VOLTAGE

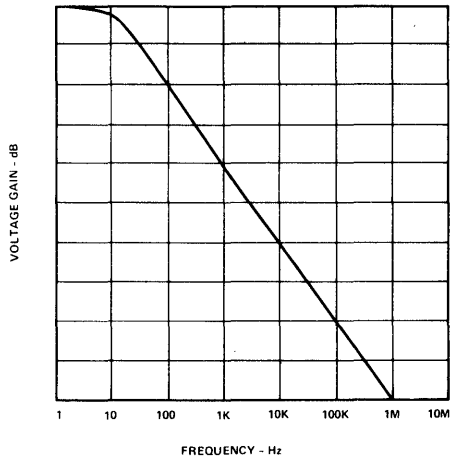

VOLTAGE FOLLOWER TRANSIENT RESPONSE

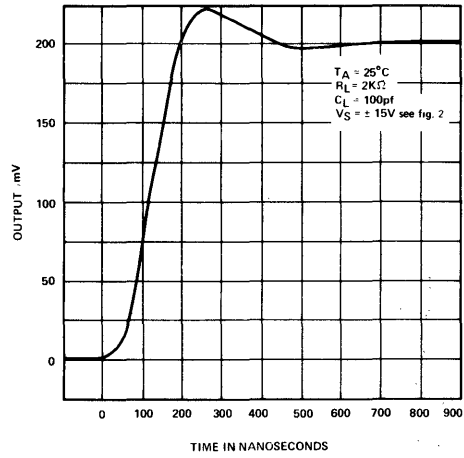

INPUT CURRENTS AS A FUNCTION OF AMBIENT TEMPERATURE

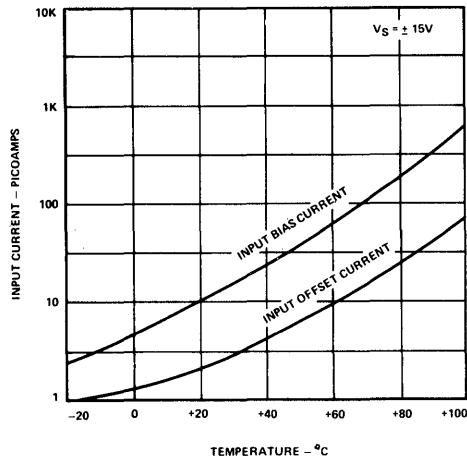

OUTPUT SHORT-CIRCUIT CURRENT AS A FUNCTION OF AMBIENT TEMPERATURE

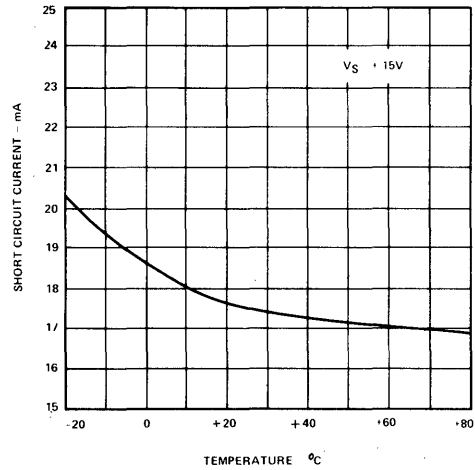

## LINEAR INTEGRATED CIRCUITS

### DESCRIPTION

The 537 is a precision operational amplifier featuring very low input bias over the full temperature range, high gain, short circuit immunity, full input protection, simple compensation, excellent temperature stability, with offset voltage null capability.

### FEATURES

- SHORT CIRCUIT PROTECTION
- OFFSET VOLTAGE NULL CAPABILITY
- LARGE COMMON-MODE AND DIFFERENTIAL VOLTAGE RANGES
- LOW POWER CONSUMPTION
- NO LATCH UP
- LOW INPUT BIAS AND OFFSET

### ABSOLUTE MAXIMUM RATINGS

Supply Voltage	
SE537	±22V
NE537	±20V
Internal Power Dissipation (Note 1)	500mW
Differential Input Voltage	±30V
Input Voltage	±Vs
Storage Temperature	-65°C to +150°C
Operating Temperature	
SE537	-55°C to +125°C
NE537	0°C to +70°C
Lead Temperature	300°C
Output Short Circuit Duration (Note 2)	Indefinite

#### NOTES:

1. Rating applies for case temperature to 125°C, derate linearly at 6.5mW/°C for ambient temperature above +5°C.
2. Short circuit may be to ground or either supply. Rating applies to +125°C case temperature or +75°C ambient temperature.

### PIN CONFIGURATION

#### T PACKAGE (Top View)

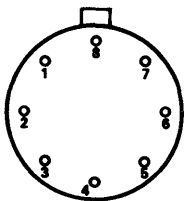

1. Freq. Comp / Offset Null
2. Inverting input
3. Noninverting input
4. V<sup>-</sup>
5. Offset Null
6. Output
7. V<sup>+</sup>
8. Freq. Comp.

ORDER PART NOS. SE537T/NE537T

### TEST CIRCUITS

#### VOLTAGE OFFSET NULL CIRCUIT

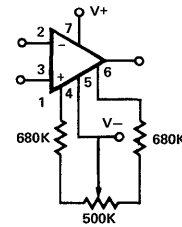

#### TRANSIENT RESPONSE TEST CIRCUIT

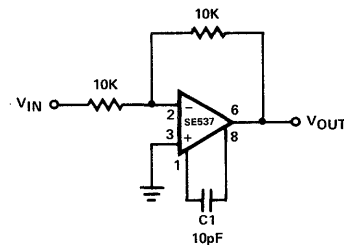



**SIGNETICS ■ SE537/NE537 – PRECISION OPERATIONAL AMPLIFIER**

**ELECTRICAL CHARACTERISTICS ( $V_S = \pm 5V$  to  $\pm 20V$  unless otherwise specified.)**

PARAMETER	CONDITIONS	NE537			SE537			UNIT
		MIN	TYP	MAX	MIN	TYP	MAX	
Input Offset Voltage	$T_A = +25^\circ C$		1.6	7.5		0.6	2.0	mV
Input Offset Voltage			2.0	10.0		1.2	3.0	mV
Input Offset Current	$T_A = +25^\circ C$		0.2	1.0		0.07	0.2	nA
Input Offset Current			0.25	1.5		0.12	0.3	nA
Input Bias Current	$T_A = +25^\circ C$		1.5	7.0		0.8	2.0	nA
Input Bias Current			2.2	10.0		1.5	3.0	nA
Input Resistance		10	50		30	70		$m\Omega$
Input Capacitance			0.5			0.5		pF
Offset Voltage Adjust Range			$\pm 15$			$\pm 15$		mV
Input Voltage Range	$V_S = \pm 15V$	$\pm 12$	$\pm 14$		$\pm 12$	$\pm 14$		V
Large Signal Voltage Gain	$R_L \geq 2k, V_{out} \pm 10V, V_S \pm 15V$ $T_A = 25^\circ C$	25k	400k		50k	500k		
Large Signal Voltage Gain	$R_L \geq 2k, V_{out} \pm 10V, V_S \pm 15V$	16k	250k		25k	300k		
Output Resistance			75			75		$\Omega$
Short Circuit Current	$T_A = +25^\circ C$		25			25		mA
Supply Voltage Rejection Ratio		80	100		80	100		dB
Common Mode Rejection Ratio	$V_{in} = \pm 12V$	80	100		86	100		dB
Supply Current	$T_A = +25^\circ C$		1.25	2.0		1.20	1.50	mA
Supply Current			1.30	3.0		1.30	2.0	mA
Unity Gain Frequency	$V_S = \pm 15V, C_C = 10pf$		250			250		KHz
Slew Rate	$V_O = \pm 5V, C_C = 10pF,$ $R_L = 2k\Omega$		0.2			0.2		V/ $\mu$ sec
Output Voltage Swing	$R_L \geq 10k, V_S \pm 15V$ $C_L = 100pF$	$\pm 13$	$\pm 13.5$		$\pm 13$	$\pm 13.5$		V
Output Voltage Swing	$R \geq 2k\Omega$	$\pm 10$	$\pm 12.6$		$\pm 10$	$\pm 12.6$		V
Temperature Range		-0		+75	-55		+125	$^\circ C$

**TYPICAL PERFORMANCE CHARACTERISTICS**

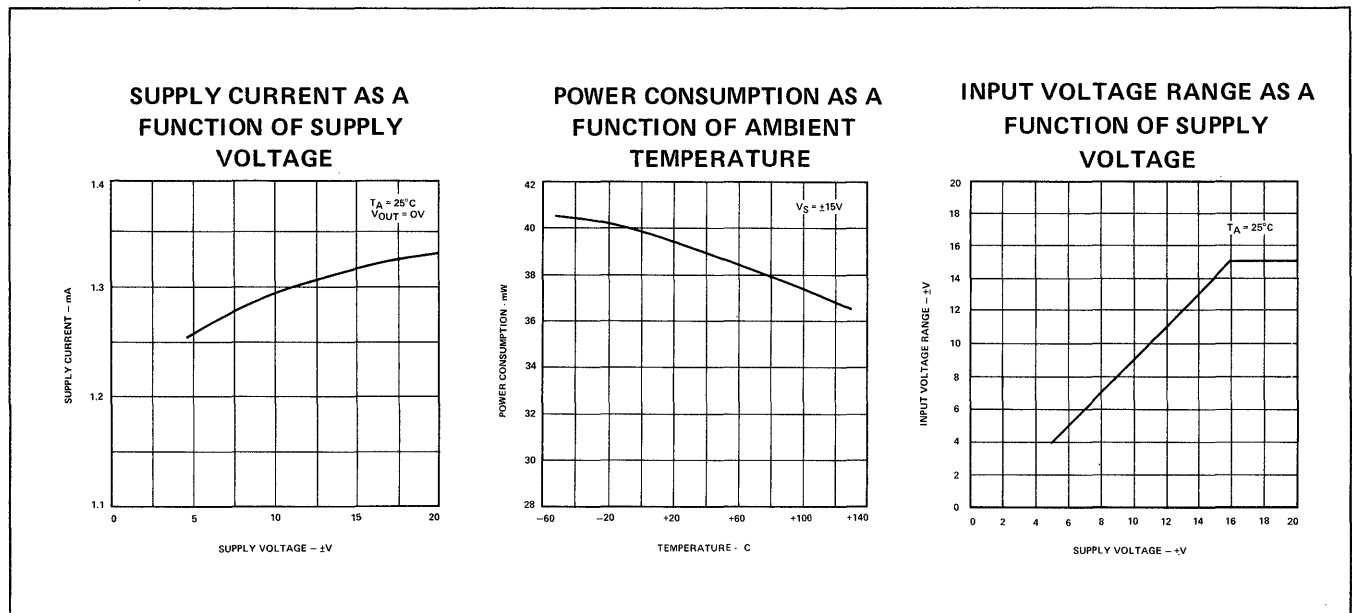

TYPICAL PERFORMANCE CHARACTERISTICS (Cont'd)

OPEN LOOP PHASE RESPONSES AND VOLTAGE GAIN AS A FUNCTION OF FREQUENCY

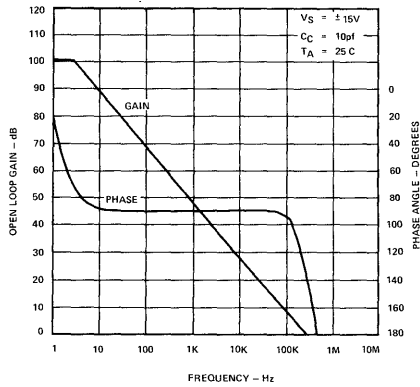

OUTPUT SHORT CIRCUIT CURRENT AS A FUNCTION OF AMBIENT TEMPERATURE

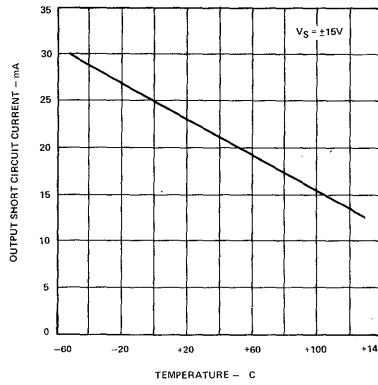

OUTPUT VOLTAGE SWING AS A FUNCTION OF LOAD RESISTANCE

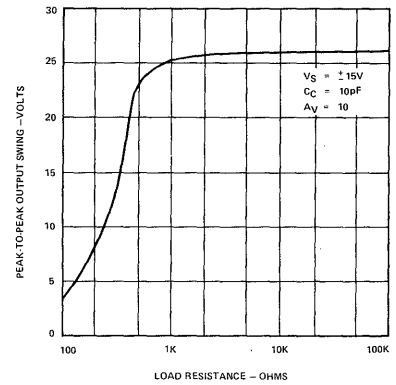

INPUT BIAS AND OFFSET CURRENTS AS FUNCTIONS OF AMBIENT TEMPERATURE

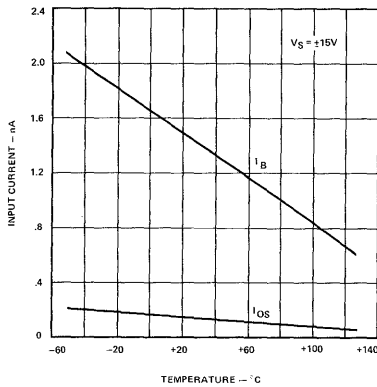

FREQUENCY CHARACTERISTICS AS A FUNCTION OF AMBIENT TEMPERATURE

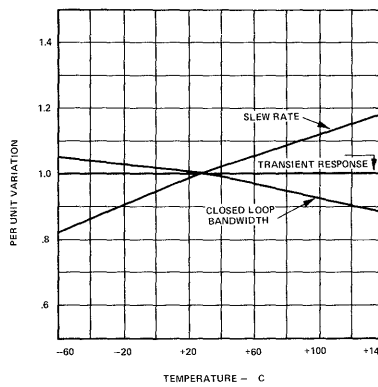

OUTPUT VOLTAGE SWING AS A FUNCTION OF FREQUENCY

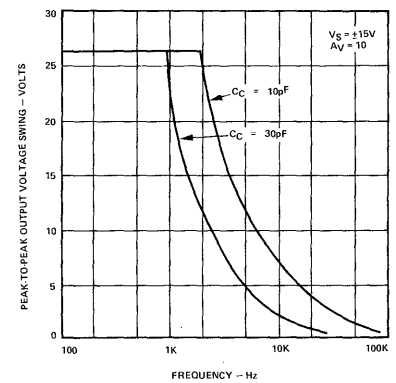

VOLTAGE FOLLOWER LARGE-SIGNAL PULSE RESPONSE

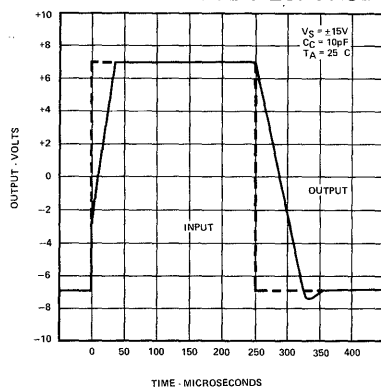

SMALL SIGNAL TRANSIENT RESPONSE

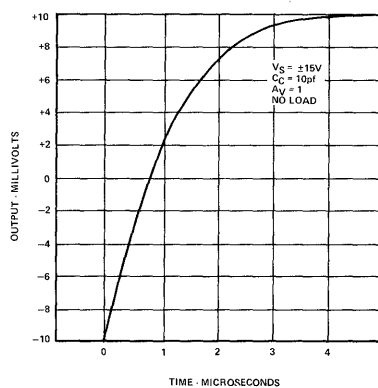

OUTPUT VOLTAGE SWING AS A FUNCTION OF SUPPLY VOLTAGE

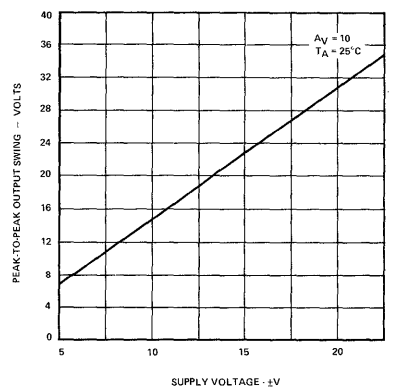

TYPICAL PERFORMANCE CHARACTERISTICS (Cont'd)

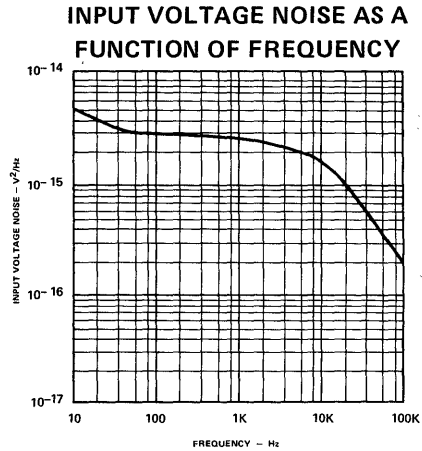
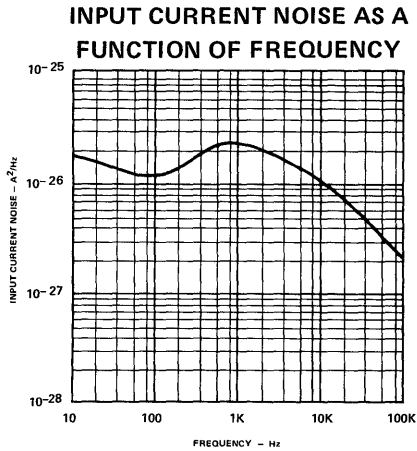

**INPUT GUARD FOR LEAKAGE**

Even with cleaned and coated boards, leakage currents can be comparable to the input bias current of the SE537. In addition the 537, as well as most other operational amplifiers, has its input pins adjacent to pins at the supply potential. In order to prevent leakage it is advisable to guard the input pins with a circuit board trace to ground.

**PRINTED CIRCUIT LAYOUT FOR INPUT GUARDING**

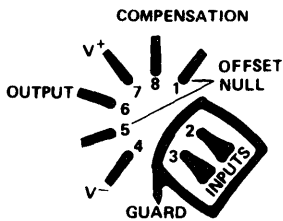

FIGURE 3a<sub>o</sub>

**INVERTING AMPLIFIER**

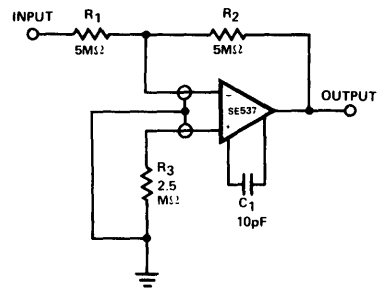

FIGURE 3b<sub>o</sub>

**NON-INVERTING AMPLIFIER**

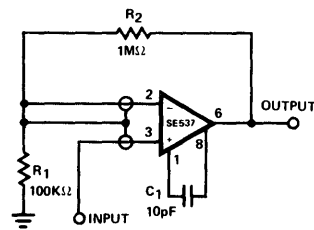
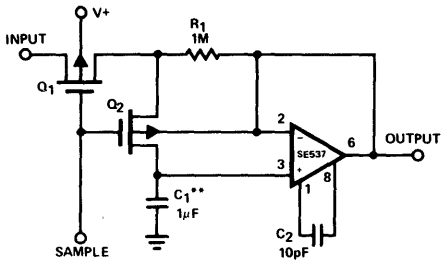

FIGURE 3c<sub>o</sub>

TYPICAL APPLICATIONS

SAMPLE AND HOLD\*



\*WORST CASE DRIFT LESS THAN 2.5mV/sec  
 \*\* TEFLON, POLYETHYLENE OR POLYCARBONATE DIELECTRIC CAPACITOR

AMPLIFIER FOR PIEZOELECTRIC TRANSDUCERS

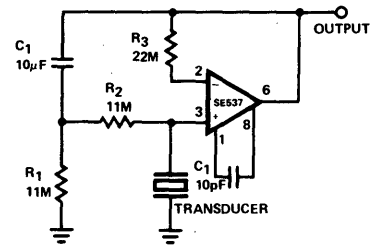

TEMPERATURE COMPENSATED LOGARITHMIC CONVERTER

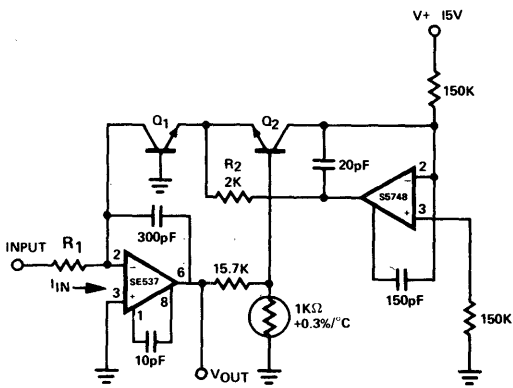

10nA < I<sub>IN</sub> < 1mA  
 SENSITIVITY 1 V/DECADE  
 "0" LEVEL 100µA

LOW DRIFT INTEGRATOR WITH RESET

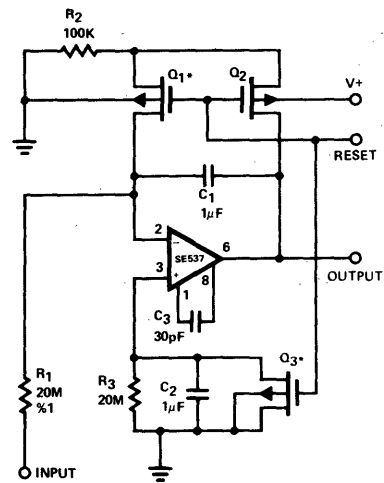

CAPACITANCE MULTIPLIER

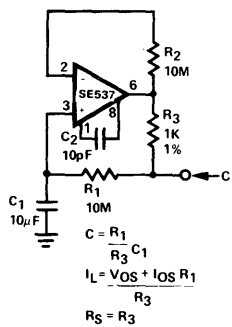

$$C = \frac{R_1}{R_3} C_1$$

$$I_L = V_{OS} + I_{OS} \frac{R_1}{R_3}$$

$$R_S = R_3$$

AMPLIFIER FOR BRIDGE TRANSDUCERS

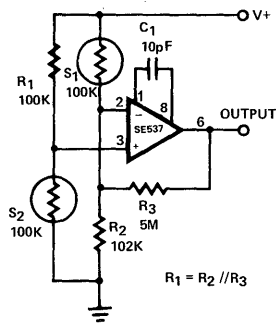

$$R_1 = R_2 // R_3$$



## LINEAR INTEGRATED CIRCUITS

### DESCRIPTION

The LM101A and LM301A are high performance operational amplifiers featuring high gain, short circuit protection, simplified compensation and excellent temperature stability.

### FEATURES

- SHORT CIRCUIT PROTECTION
- OFFSET VOLTAGE NULL CAPABILITY
- LARGE COMMON-MODE AND DIFFERENTIAL VOLTAGE RANGES
- LOW POWER CONSUMPTION
- NO LATCH UP

### ABSOLUTE MAXIMUM RATINGS

Supply Voltage	LM101A	±22V
	LM301A	±18V
Power Dissipation (Note 1)		500mW
Differential Input Voltage		±30V
Input Voltage (Note 2)		±15V
Output Short Circuit Duration		Indefinite
Operating Temperature Range	LM101A	-55°C to 125°C
	LM301A	0°C to 70°C
Storage Temperature Range		-65°C to 150°C
Lead Temperature (Soldering, 60 sec.)		300°C

### NOTES:

1. Absolute maximum rating holds for all packages. The maximum junction temperature is 150°C for the LM101A and 100°C for the LM301A. For operation at elevated temperatures, derate according to appropriate thermal resistances given under package information.
2. For supply voltages less than ±15V, the absolute maximum input voltage is equal to the supply voltage.

### EQUIVALENT CIRCUIT

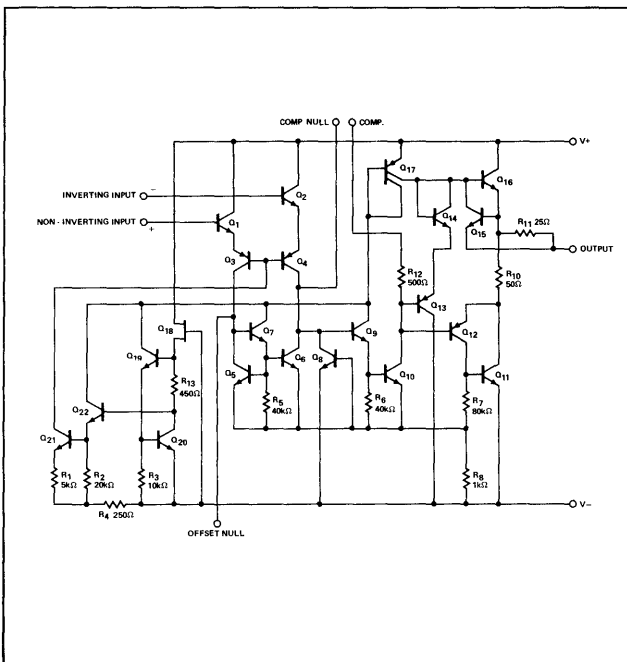

### PIN CONFIGURATIONS

#### A & F PACKAGE (Top View)

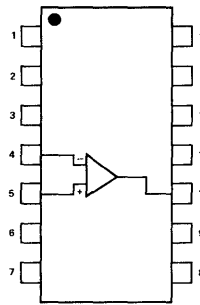

1. NC
2. NC
3. Freq. Comp./Offset Null
4. Inverting Input
5. Noninverting Input
6. V<sup>-</sup>
7. NC
8. NC
9. Offset Null
10. Output
11. V<sup>+</sup>
12. Freq. Comp.
13. NC
14. NC

#### ORDER PART NOS.

LM101AD/LM301AD LM101AN-14/LM301AN-14

#### G PACKAGE

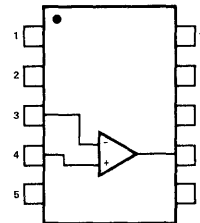

1. NC
2. Bal/Comp
3. Input
4. Input
5. V<sup>-</sup>
6. Bal
7. Output
8. V<sup>+</sup>
9. Comp
10. NC

#### ORDER PART NOS.

LM101AF/LM301AF

#### T PACKAGE

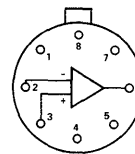

1. Freq. Comp./Offset Null
2. Inverting Input
3. Noninverting Input
4. V<sup>-</sup>
5. Offset Null
6. Output
7. V<sup>+</sup>
8. Freq. Comp.

#### ORDER PART NOS.

LM101AH/LM301AH

#### V PACKAGE

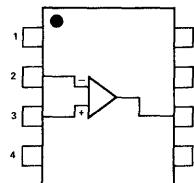

1. Freq. Comp./Offset Null
2. Inverting Input
3. Noninverting Input
4. V<sup>-</sup>
5. Offset Null
6. Output
7. V<sup>+</sup>
8. Freq. Comp.

#### ORDER PART NO.

LM301AN

**SIGNETICS ■ LM101A/301A – HIGH PERFORMANCE OPERATIONAL AMPLIFIER**
**LM101A**
**ELECTRICAL CHARACTERISTICS** ( $-55^{\circ}\text{C} \leq T_A \leq 125^{\circ}\text{C}$ ,  $\pm 5\text{V} \leq V_S \leq \pm 20\text{V}$  and  $C_1 = 30\text{pF}$  unless otherwise specified.)

PARAMETER	CONDITIONS	MIN	TYP	MAX	UNITS
Input Offset Voltage	$T_A = 25^{\circ}\text{C}$ , $R_S \leq 50\text{k}\Omega$		0.7	2.0	mV
Input Offset Current	$T_A = 25^{\circ}\text{C}$		1.5	10	nA
Input Bias Current	$T_A = 25^{\circ}\text{C}$		30	75	nA
Input Resistance*	$T_A = 25^{\circ}\text{C}$	1.5	4		M $\Omega$
Supply Current	$T_A = 25^{\circ}\text{C}$ , $V_S = \pm 20\text{V}$		1.8	3.0	mA
Large Signal Voltage Gain	$T_A = 25^{\circ}\text{C}$ , $V_S = \pm 15\text{V}$ $V_{\text{OUT}} = \pm 10\text{V}$ , $R_L \geq 2\text{k}\Omega$	50	160		V/mV
Input Offset Voltage	$R_S \leq 50\text{k}\Omega$			3.0	mV
Average Temperature Coefficient of Input Offset Voltage			3.0	15	$\mu\text{V}/^{\circ}\text{C}$
Input Offset Current				20	nA
Average Temperature Coefficient of Input Offset Current	$25^{\circ}\text{C} \leq T_A \leq 125^{\circ}\text{C}$ $-55^{\circ}\text{C} \leq T_A \leq 25^{\circ}\text{C}$		0.01 0.02	0.1 0.2	nA/ $^{\circ}\text{C}$ nA/ $^{\circ}\text{C}$
Input Bias Current				100	nA
Supply Current	$T_A = +125^{\circ}\text{C}$ , $V_S = \pm 20\text{V}$		1.2	2.5	mA
Large Signal Voltage Gain	$V_S = \pm 15\text{V}$ , $V_{\text{OUT}} = \pm 10\text{V}$ $R_L \geq 2\text{k}\Omega$	25			V/mV
Output Voltage Swing	$V_S = \pm 15\text{V}$ , $R_L = 10\text{k}\Omega$ $R_L = 2\text{k}\Omega$	$\pm 12$ $\pm 10$	$\pm 14$ $\pm 13$		V V
Input Voltage Range	$V_S = \pm 20\text{V}$	$\pm 15$			V
Common Mode Rejection Ratio	$R_S \leq 50\text{k}\Omega$	80	96		dB
Supply Voltage Rejection Ratio	$R_S \leq 50\text{k}\Omega$	80	96		dB

**LM301A**
**ELECTRICAL CHARACTERISTICS** ( $0^{\circ}\text{C} \leq T_A < 70^{\circ}\text{C}$ ,  $\pm 5\text{V} \leq V_S \leq \pm 15\text{V}$  and  $C_1 = 30\text{pF}$  unless otherwise specified.)

PARAMETER	CONDITIONS	MIN	TYP	MAX	UNIT
Input Offset Voltage	$T_A = 25^{\circ}\text{C}$ , $R_S \leq 50\text{k}\Omega$		2.0	7.5	mV
Input Offset Current	$T_A = 25^{\circ}\text{C}$		3	50	nA
Input Bias Current	$T_A = 25^{\circ}\text{C}$		70	250	nA
Input Resistance	$T_A = 25^{\circ}\text{C}$	0.5	2		M $\Omega$
Supply Current	$T_A = 25^{\circ}\text{C}$ , $V_S = \pm 15\text{V}$		1.8	3.0	mA
Large Signal Voltage Gain	$T_A = 25^{\circ}\text{C}$ , $V_S = \pm 15\text{V}$ $V_{\text{OUT}} = \pm 10\text{V}$ ; $R_L \geq 2\text{k}\Omega$	25	160		V/mV
Input Offset Voltage	$R_S \leq 50\text{k}\Omega$			10	mV
Average Temperature Coefficient of Input Offset Voltage			6.0	30	$\mu\text{V}/^{\circ}\text{C}$
Input Offset Current				70	nA
Average Temperature Coefficient of Input Offset Current	$25^{\circ}\text{C} \leq T_A \leq 70^{\circ}\text{C}$ $0^{\circ}\text{C} \leq T_A \leq 25^{\circ}\text{C}$		0.01 0.02	0.3 0.6	nA/ $^{\circ}\text{C}$ nA/ $^{\circ}\text{C}$
Input Bias Current				300	nA
Large Signal Voltage Gain	$V_S = \pm 15\text{V}$ , $V_{\text{OUT}} = \pm 10\text{V}$ $R_L \geq 2\text{k}\Omega$	15			V/mV
Output Voltage Swing	$V_S = \pm 15\text{V}$ , $R_L = 10\text{k}\Omega$ $R_L = 2\text{k}\Omega$	$\pm 12$ $\pm 10$	$\pm 14$ $\pm 13$		V V
Input Voltage Range	$V_S = \pm 15\text{V}$	$\pm 12$			V
Common Mode Rejection Ratio	$R_S \leq 50\text{k}\Omega$	70	90		dB
Supply Voltage Rejection Ratio	$R_S \leq 50\text{k}\Omega$	70	96		dB

TYPICAL CHARACTERISTIC CURVES

LM101A

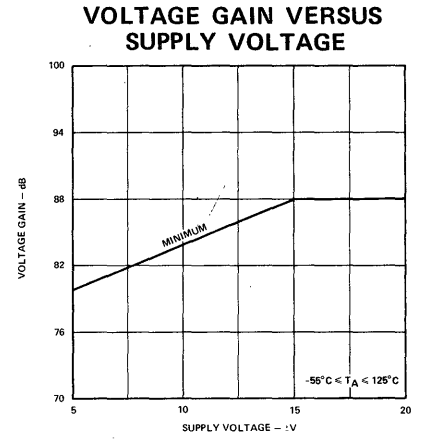
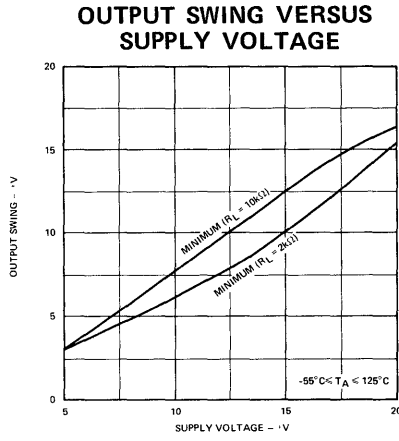
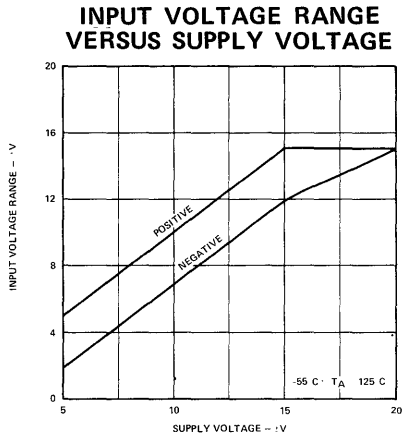

LM301A

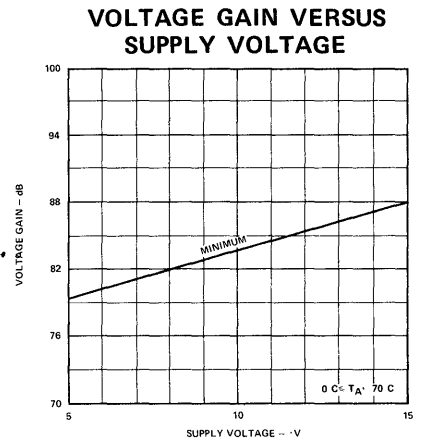
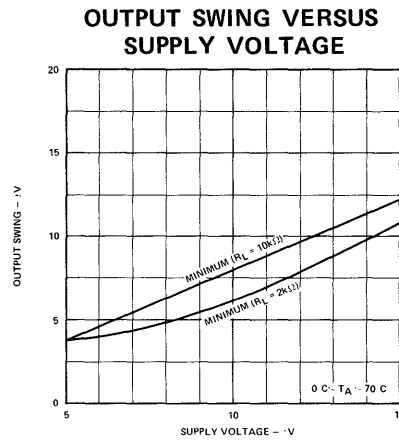
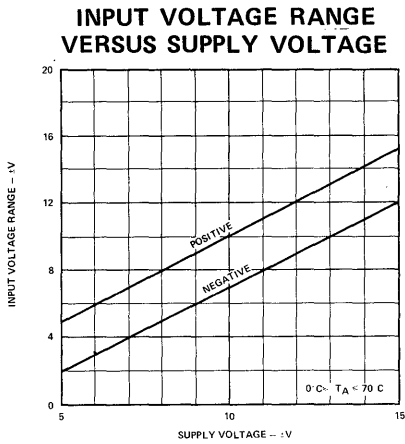

LM101A

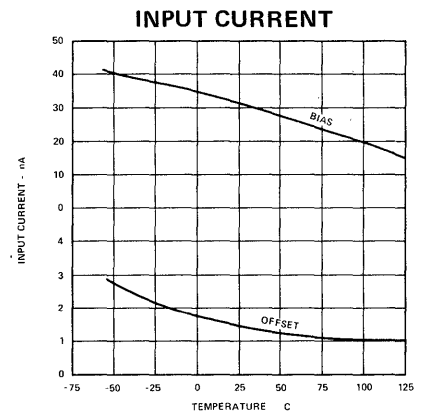
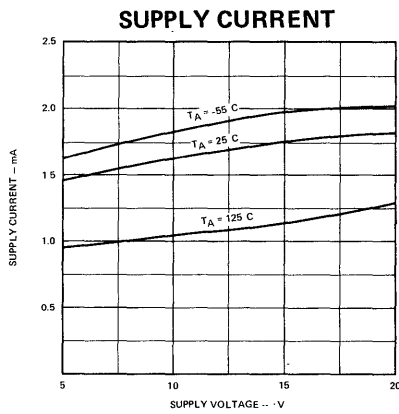
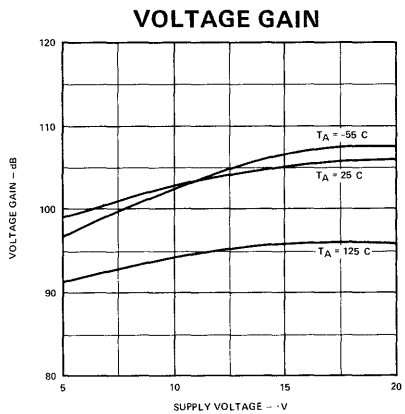



TYPICAL CHARACTERISTIC CURVES (Cont'd.)

LM301A

VOLTAGE GAIN

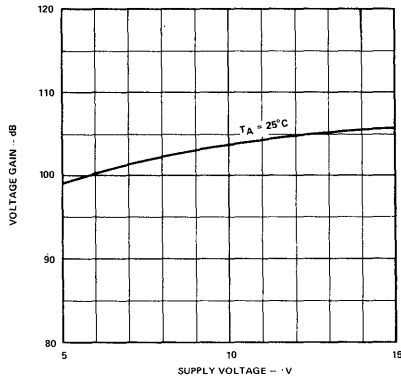

SUPPLY CURRENT

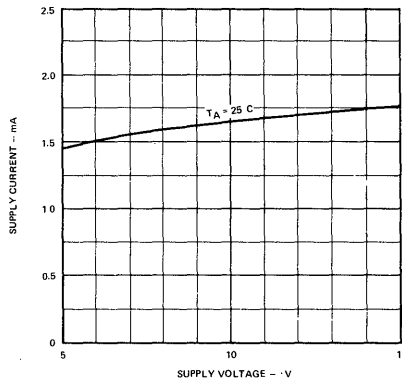

INPUT CURRENT

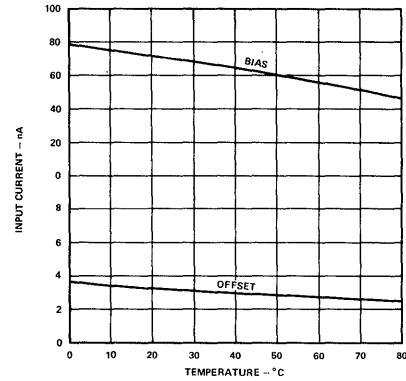

CURRENT LIMITING

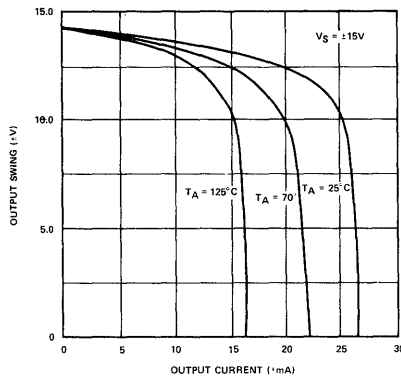

INPUT NOISE VOLTAGE

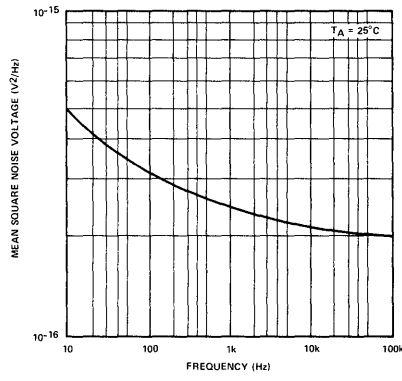

INPUT NOISE CURRENT

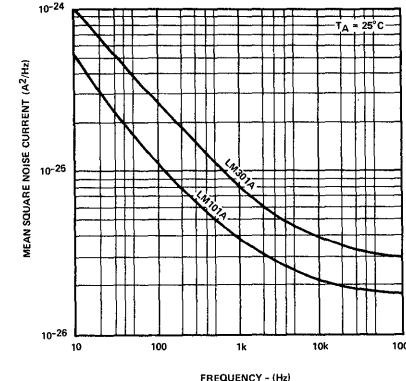

COMMON MODE REJECTION

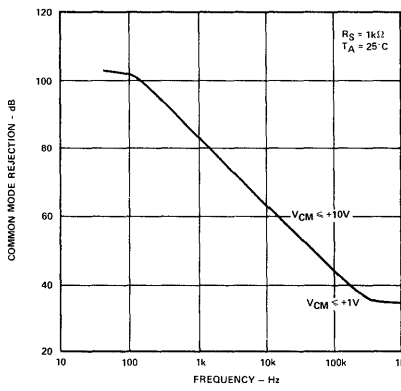

POWER SUPPLY REJECTION

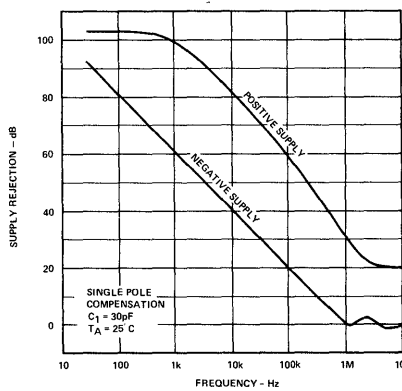

CLOSED LOOP OUTPUT IMPEDANCE

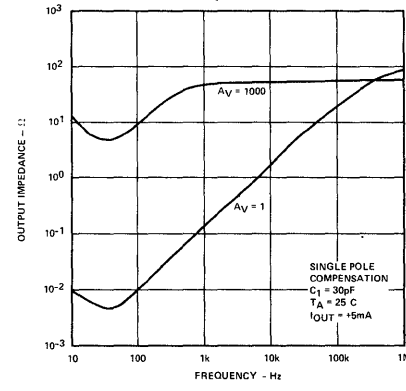

TYPICAL CHARACTERISTIC CURVES (Cont'd.)

SINGLE POLE COMPENSATION

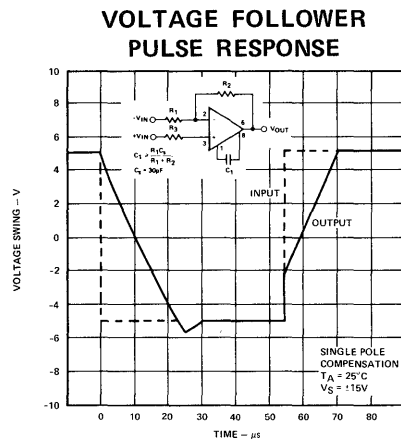
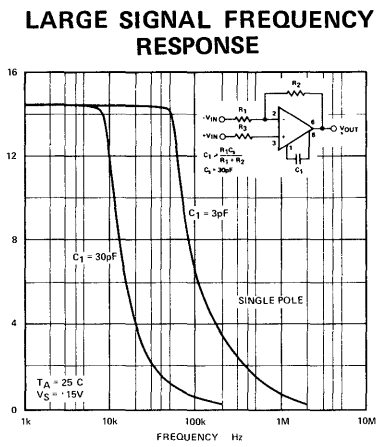
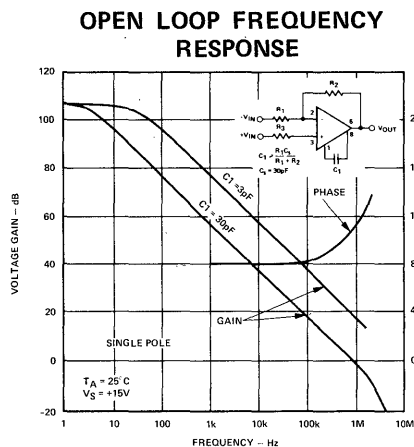

TWO POLE COMPENSATION

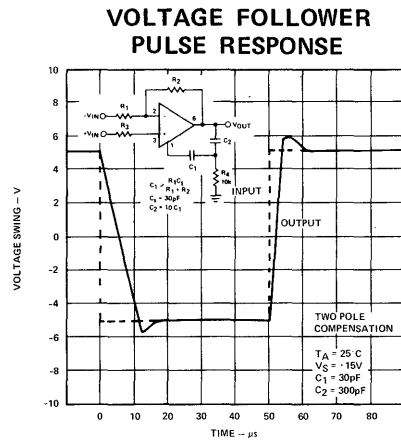
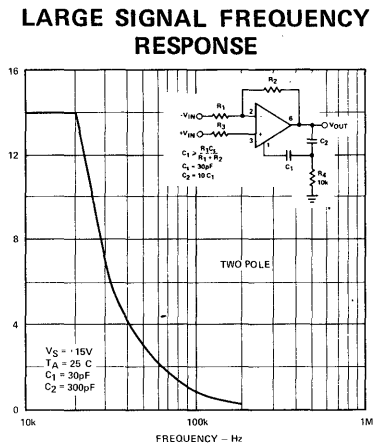
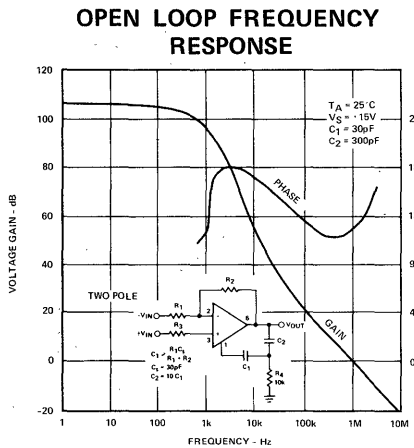

FEED FORWARD COMPENSATION

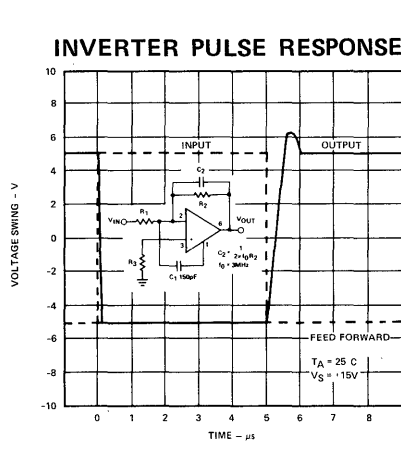
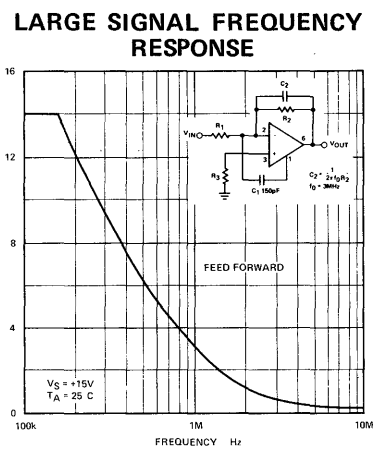
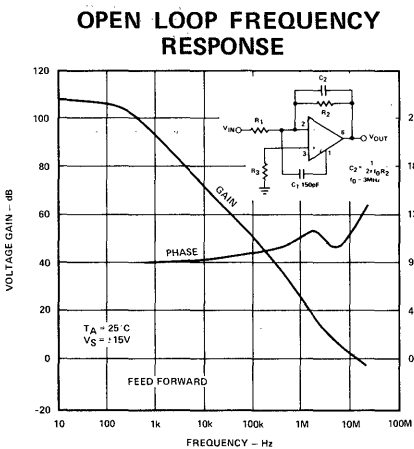

TYPICAL APPLICATIONS (Pin numbers shown refer to T or V package only)

**FAST SUMMING AMPLIFIER**

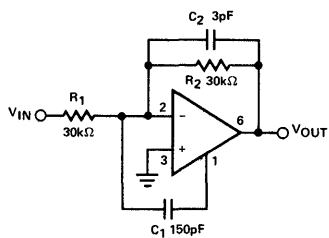

Power Bandwidth: 250kHz  
 Small Signal Bandwidth: 3.5MHz  
 Slew Rate: 10V/μs

**LOW FREQUENCY SQUARE WAVE GENERATOR**

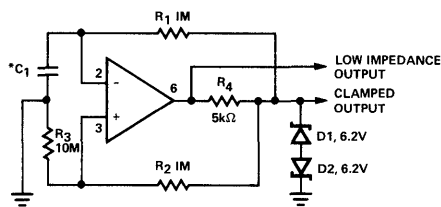

\*Adjust C<sub>1</sub> for frequency

**PRACTICAL DIFFERENTIATOR**

$$f_c = \frac{1}{2\pi R_2 C_1}$$

$$f_n = \frac{1}{2\pi R_1 C_1}$$

$$= \frac{1}{2\pi R_2 C_2}$$

$$f_c < f_n < f_{\text{unity gain}}$$

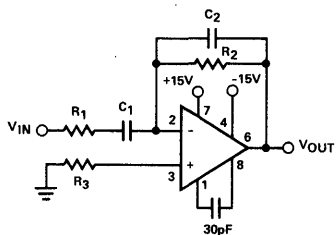

**FREE-RUNNING MULTIVIBRATOR**

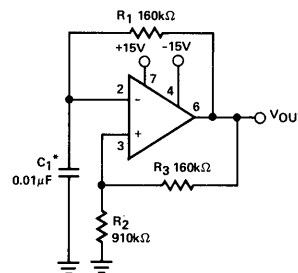

\*Chosen for oscillation at 100Hz

**PULSE WIDTH MODULATOR**

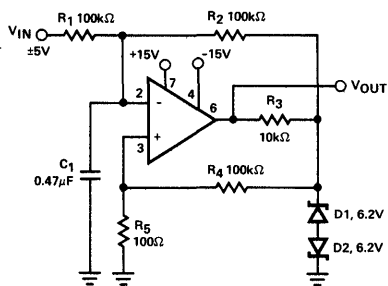

**GAIN TEST CIRCUIT**

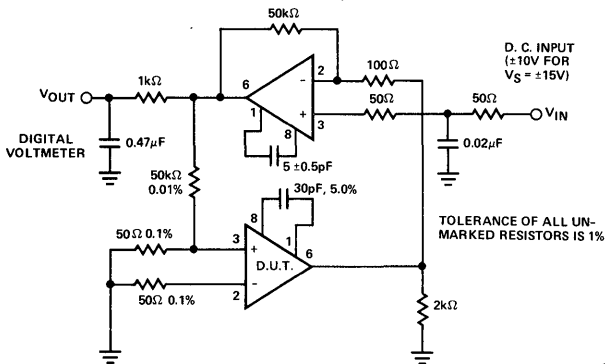

$$A_{VO} = \frac{V_{IN} \times 10^3}{V_{OUT}}$$

**VOLTAGE COMPARATOR FOR DRIVING RTL LOGIC OR HIGH CURRENT DRIVER**

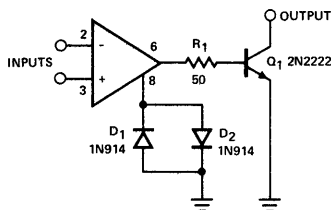

**INVERTING AMPLIFIER WITH BALANCING CIRCUIT**

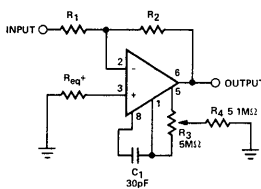

\*May be zero or equal to parallel combination of R<sub>1</sub> and R<sub>2</sub> for minimum offset.

**FAST VOLTAGE FOLLOWER**

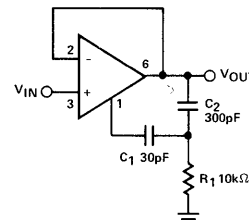

Power Bandwidth: 15kHz  
 Slew Rate: 1V/μs

## LINEAR INTEGRATED CIRCUITS

### DESCRIPTION

The LM101 and LM201 are high performance operational amplifiers featuring high gain, short circuit protection, simplified compensation and excellent temperature stability.

### FEATURES

- SHORT CIRCUIT PROTECTION
- OFFSET VOLTAGE NULL CAPABILITY
- LARGE COMMON-MODE AND DIFFERENTIAL VOLTAGE RANGES
- LOW POWER CONSUMPTION
- NO LATCH UP

### ABSOLUTE MAXIMUM RATINGS

Supply Voltage	±22V
Power Dissipation (Note 1)	500mW
Differential Input Voltage	±30V
Input Voltage (Note 2)	±15V

Output Short Circuit Duration	Indefinite
Operating Temperature Range	LM101 -55°C to 125°C
	LM201 0°C to 70°C

Storage Temperature Range	-65°C to 150°C
Lead Temperature (Soldering, 60 sec.)	300°C

### NOTES

1. Absolute maximum rating holds for all packages. The maximum junction temperature is 150°C for the LM101 and 100°C for the LM201. For operation at elevated temperatures, derate according to appropriate thermal resistances given under package information.
2. For supply voltages less than ±15V, the absolute maximum input voltage is equal to the supply voltage.

### EQUIVALENT CIRCUIT

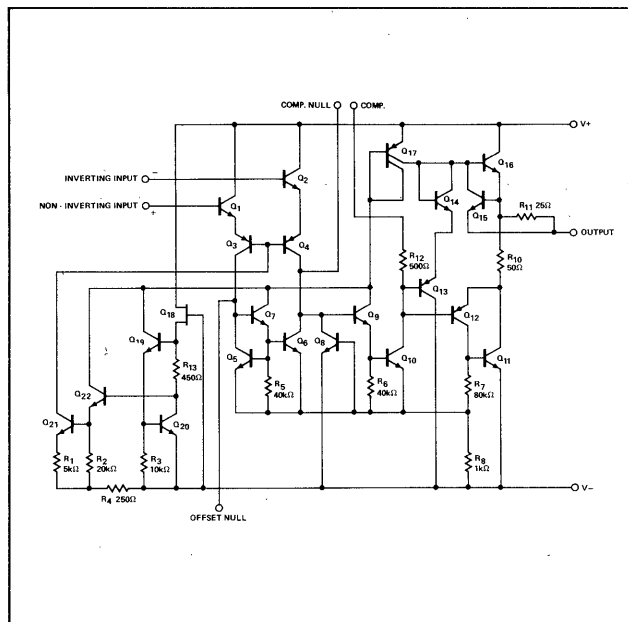

### PIN CONFIGURATIONS

#### A & F PACKAGE (Top View)

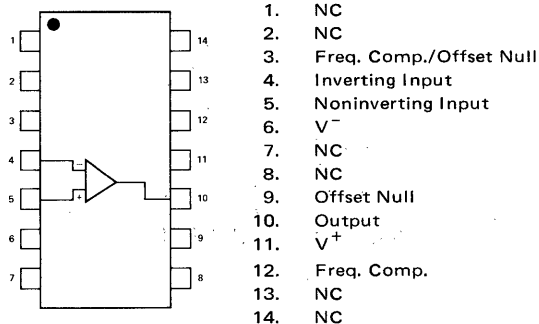

ORDER PART NOS.

LM101N-14	}	Silicone	LM101D	}	Ceramic
LM201N-14			LM201D		

#### G PACKAGE

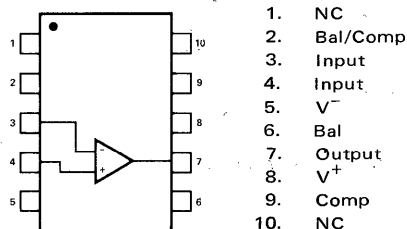

ORDER PART NOS.

LM101F/LM201F

#### T PACKAGE

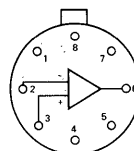

1. Freq. Comp/Offset Null
2. Inverting Input
3. Noninverting Input
4. V-
5. Offset Null
6. Output
7. V+
8. Freq. Comp.

ORDER PART NOS.

LM101H/LM201H

#### V PACKAGE

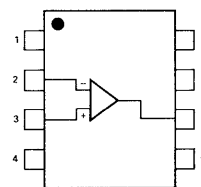

1. Freq. Comp./Offset Null
2. Inverting Input
3. Noninverting Input
4. V-
5. Offset Null
6. Output
7. V+
8. Freq. Comp.

ORDER PART NO. LM201N

**SIGNETICS ■ LM101/201 – HIGH PERFORMANCE OPERATIONAL AMPLIFIER**

**ELECTRICAL CHARACTERISTICS**  $-55^{\circ}\text{C} \leq T_A \leq 125^{\circ}\text{C}$ ,  $\pm 15\text{V} \leq V_S \leq \pm 20\text{V}$  and  $C_1 = 30\text{pF}$  (unless otherwise specified).

LM101	PARAMETER	CONDITIONS	MIN.	TYP.	MAX.	UNITS
	Input Offset Voltage	$T_A = 25^{\circ}\text{C}$ , $R_S \leq 10\text{k}\Omega$		1.0	5.0	mV
	Input Offset Current	$T_A = 25^{\circ}\text{C}$		40	200	nA
	Input Bias Current	$T_A = 25^{\circ}\text{C}$		120	500	nA
	Input Resistance	$T_A = 25^{\circ}\text{C}$	300	800		k $\Omega$
	Supply Current	$T_A = 25^{\circ}\text{C}$ , $V_S = \pm 20\text{V}$		1.8	3.0	mA
	Large Signal Voltage Gain	$T_A = 25^{\circ}\text{C}$ , $V_S = \pm 15\text{V}$ $V_{\text{OUT}} = \pm 10\text{V}$ , $R_L \geq 2\text{k}\Omega$	50	160		V/mV
	Input Offset Voltage	$R_S \leq 10\text{k}\Omega$			6.0	mV
	Average Temperature Coefficient of Input Offset Voltage	$R_S \leq 50\Omega$		3.0		$\mu\text{V}/^{\circ}\text{C}$
		$R_S \leq 10\text{k}\Omega$		6.0		$\mu\text{V}/^{\circ}\text{C}$
	Input Offset Current	$T_A = +125^{\circ}\text{C}$ $T_A = -55^{\circ}\text{C}$		10 100	200 500	nA nA
	Input Bias Current	$T_A = -55^{\circ}\text{C}$		0.28	1.5	$\mu\text{A}$
	Supply Current	$T_A = +125^{\circ}\text{C}$ , $V_S = \pm 20\text{V}$		1.2	2.5	mA
	Large Signal Voltage Gain	$V_S = \pm 15\text{V}$ , $V_{\text{OUT}} = \pm 10\text{V}$ $R_L \geq 2\text{k}\Omega$	25			V/mV
	Output Voltage Swing	$V_S = \pm 15\text{V}$ , $R_L = 10\text{k}\Omega$ $R_L = 2\text{k}\Omega$	$\pm 12$ $\pm 10$	$\pm 14$ $\pm 13$		V V
	Input Voltage Range	$V_S = \pm 15\text{V}$	$\pm 12$			V
	Common Mode Rejection Ratio	$R_S \leq 10\text{k}\Omega$	70	90		dB
	Supply Voltage Rejection Ratio	$R_S \leq 10\text{k}\Omega$	70	90		dB

LM201	PARAMETER	CONDITIONS	MIN.	TYP.	MAX.	UNITS
	Input Offset Voltage	$T_A = 25^{\circ}\text{C}$ , $R_S \leq 10\text{k}\Omega$		2.0	7.5	mV
	Input Offset Current	$T_A = 25^{\circ}\text{C}$		100	500	nA
	Input Bias Current	$T_A = 25^{\circ}\text{C}$		0.25	1.5	$\mu\text{A}$
	Input Resistance	$T_A = 25^{\circ}\text{C}$	100	400		k $\Omega$
	Supply Current	$T_A = 25^{\circ}\text{C}$ , $V_S = \pm 20\text{V}$		1.8	3.0	mA
	Large Signal Voltage Gain	$T_A = 25^{\circ}\text{C}$ , $V_S = \pm 15\text{V}$ $V_{\text{OUT}} = \pm 10\text{V}$ , $R_L \geq 2\text{k}\Omega$	20	150		V/mV
	Input Offset Voltage	$R_S \leq 10\text{k}\Omega$			10	mV
	Average Temperature Coefficient of Input Offset Voltage	$R_S \leq 50\Omega$		6		$\mu\text{V}/^{\circ}\text{C}$
		$R_S \leq 10\text{k}\Omega$		10		$\mu\text{V}/^{\circ}\text{C}$
	Input Offset Current	$T_A = +70^{\circ}\text{C}$ $T_A = 0^{\circ}\text{C}$		50 150	400 750	nA nA
	Input Bias Current	$T_A = 0^{\circ}\text{C}$		0.32	2.0	$\mu\text{A}$
	Large Signal Voltage Gain	$V_S = \pm 15\text{V}$ , $V_{\text{OUT}} = \pm 10\text{V}$ $R_L \geq 2\text{k}\Omega$	15			V/mV
	Output Voltage Swing	$V_S = \pm 15\text{V}$ , $R_L = 10\text{k}\Omega$ $R_L = 2\text{k}\Omega$	$\pm 12$ $\pm 10$	$\pm 14$ $\pm 13$		V V
	Input Voltage Range	$V_S = \pm 15\text{V}$	$\pm 12$			V
	Common Mode Rejection Ratio	$R_S \leq 10\text{k}\Omega$	65	90		dB
	Supply Voltage Rejection Ratio	$R_S \leq 10\text{k}\Omega$	70	90		dB

TYPICAL CHARACTERISTIC CURVES

LM101

INPUT VOLTAGE RANGE  
VERSUS SUPPLY VOLTAGE

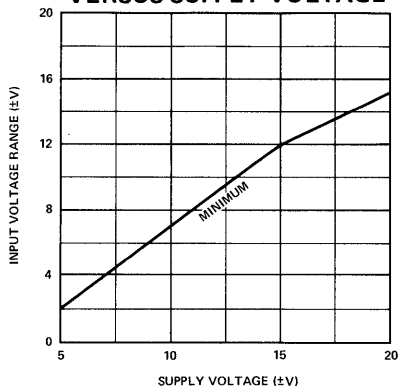

OUTPUT SWING VERSUS  
SUPPLY VOLTAGE

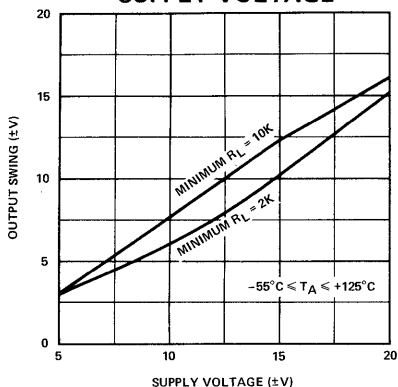

VOLTAGE GAIN VERSUS  
SUPPLY VOLTAGE

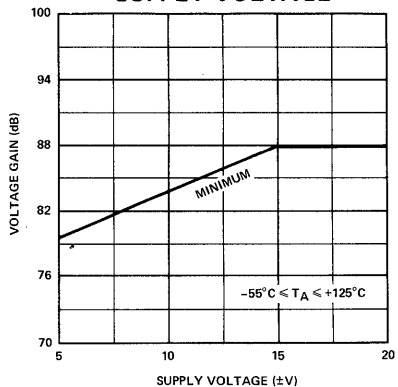

LM201

INPUT VOLTAGE RANGE  
VERSUS SUPPLY VOLTAGE

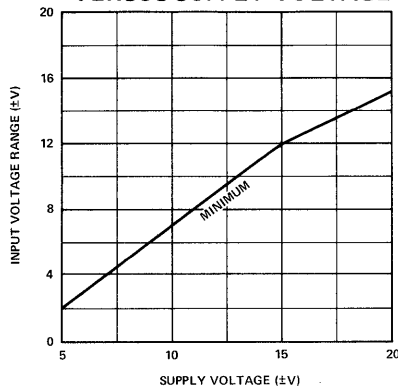

OUTPUT SWING VERSUS  
SUPPLY VOLTAGE

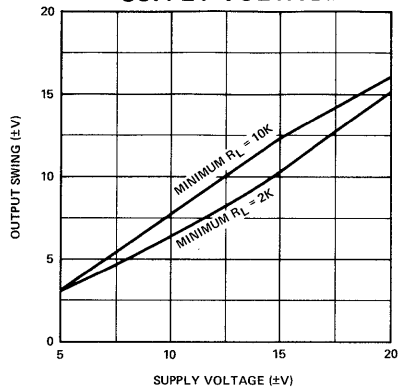

VOLTAGE GAIN VERSUS  
SUPPLY VOLTAGE

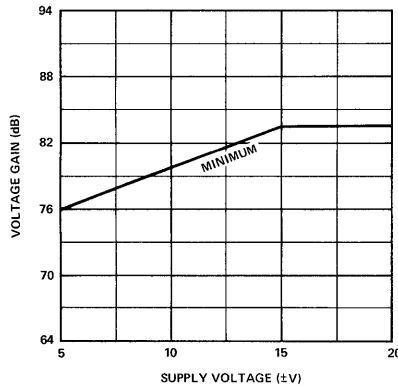

TYPICAL CHARACTERISTIC CURVES (Cont'd.)

LM101

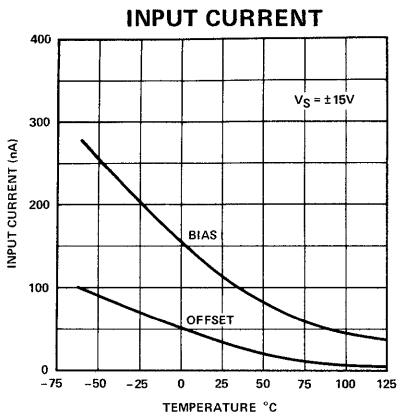
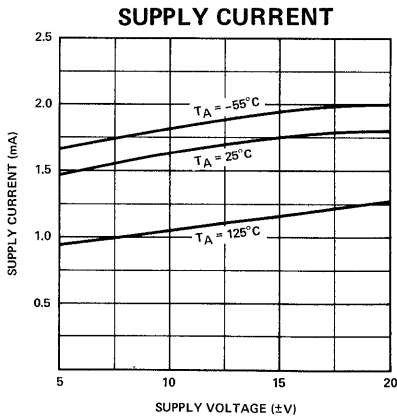
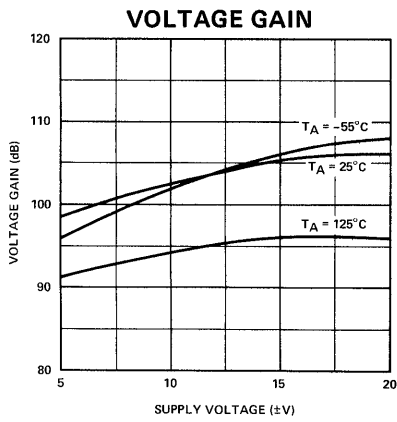

LM201

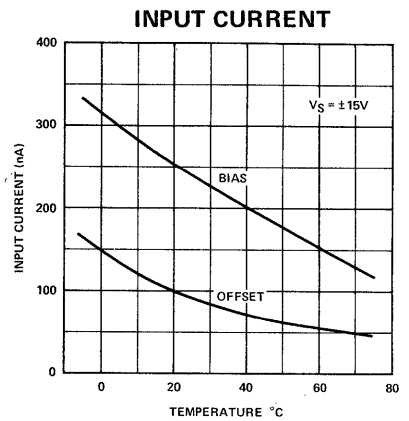
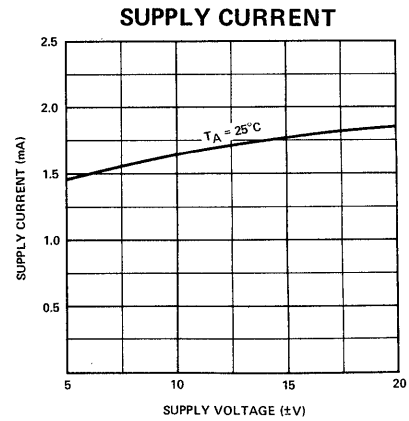
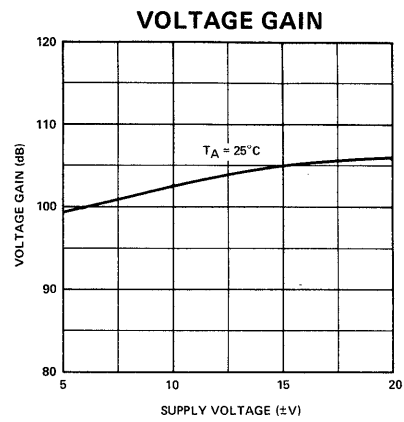

TYPICAL CHARACTERISTIC CURVES (Cont'd.)

LM101

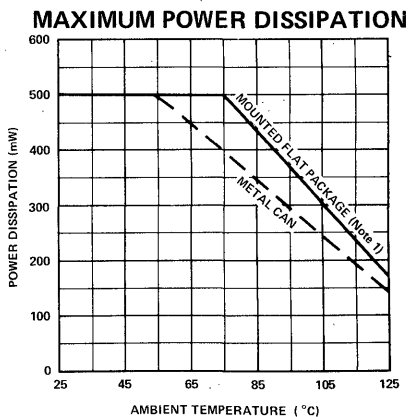
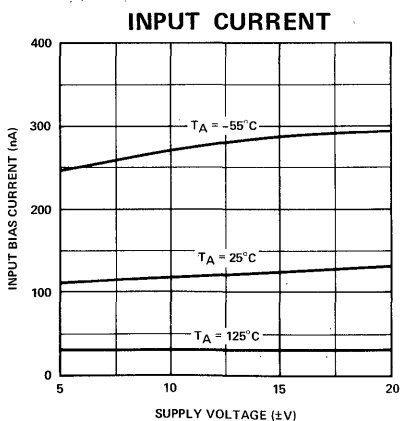
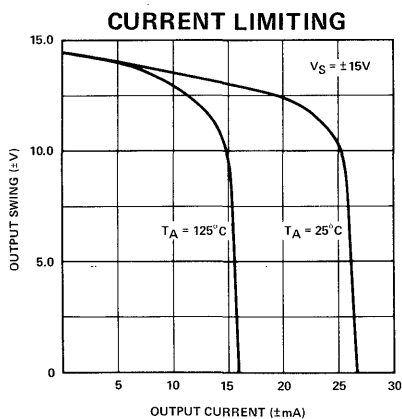

LM201

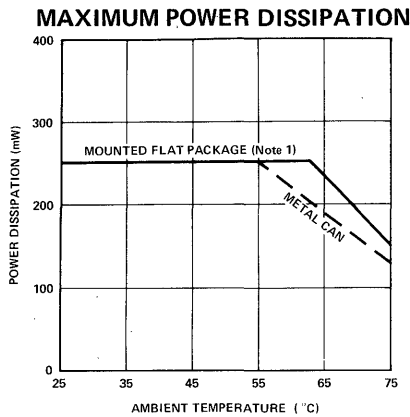
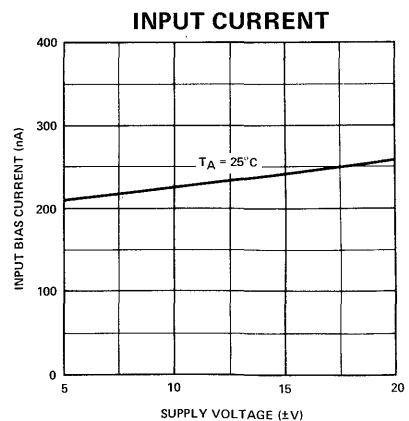
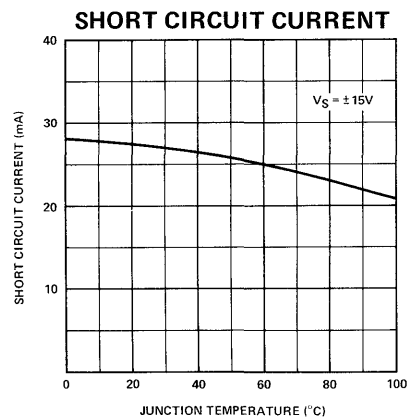



TYPICAL CHARACTERISTIC CURVES (Cont'd.)

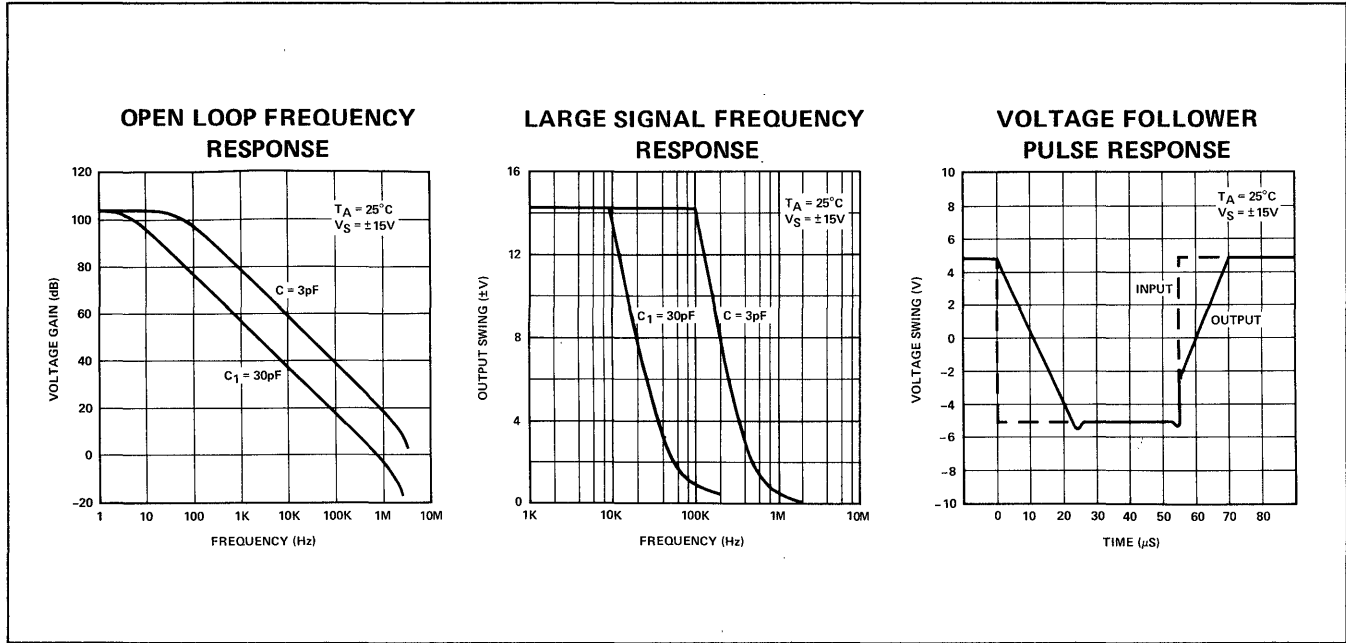

TYPICAL APPLICATIONS (Pin numbers shown refer to T or V package only)

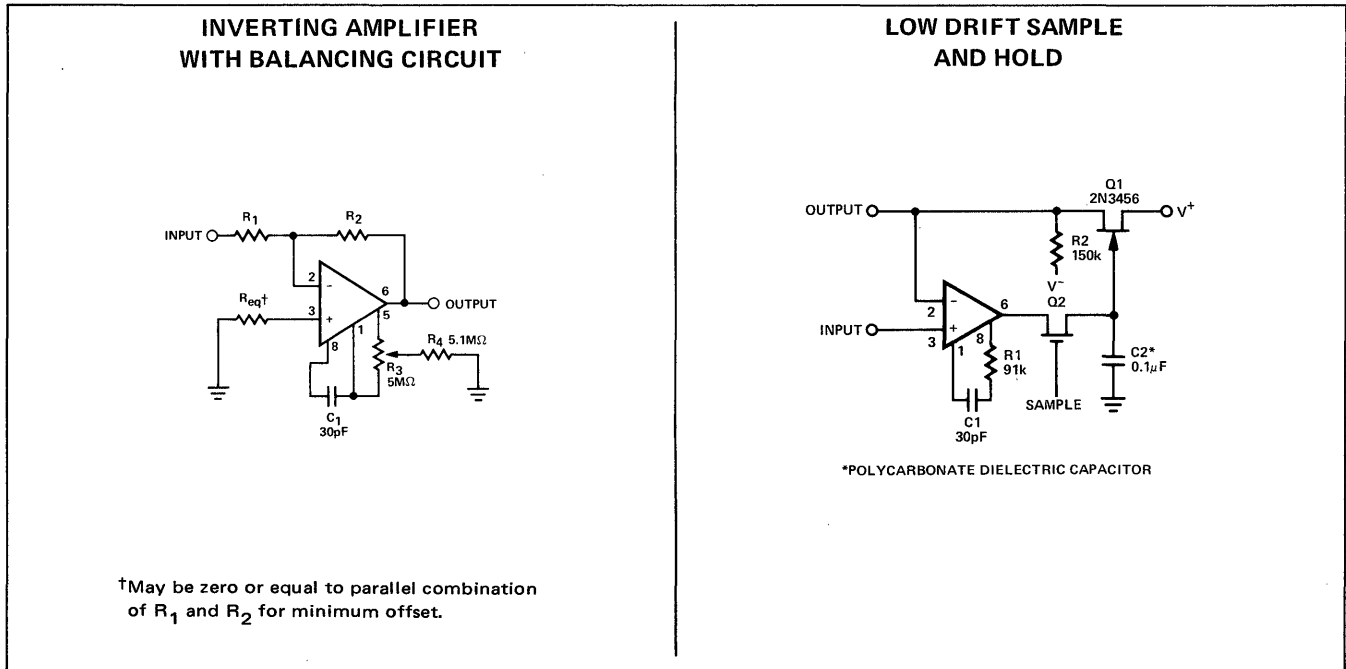

## LINEAR INTEGRATED CIRCUITS

### DESCRIPTION

The LM107/307 is a general purpose internally compensated operational amplifier. Advanced processing techniques provide input currents which are an order of magnitude lower than the  $\mu A709$ . Standard pin out allows plug in replacement for the  $\mu A709$ , LM101, LM101A, and the  $\mu A741$ .

### FEATURES

- 3mV MAX OFFSET VOLTAGE OVER TEMP
- 100 nA MAX INPUT CURRENT OVER TEMP
- 20 nA MAX INPUT OFFSET CURRENT OVER TEMP
- OFFSETS GUARANTEED OVER COMMON MODE RANGE
- INPUT/OUTPUT SHORT CIRCUIT PROTECTED

### ABSOLUTE MAXIMUM RATINGS

Supply Voltage	LM107	$\pm 22V$
	LM307	$\pm 18V$
Power Dissipation (Note 1)		500 mW
Differential Input Voltage		$\pm 30V$
Input Voltage (Note 2)		$\pm 15V$
Output Short-Circuit Duration (Note 3)		Indefinite
Operating Temperature Range	LM107	$-55^{\circ}C$ to $125^{\circ}C$
	LM307	$0^{\circ}C$ to $70^{\circ}C$
Storage Temperature Range		$-65^{\circ}C$ to $150^{\circ}C$
Lead Temperature (Soldering, 60 sec)		$300^{\circ}C$

### PIN CONFIGURATIONS

#### T PACKAGE (Top View)

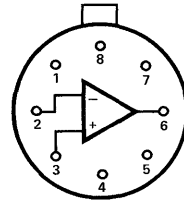

- |    |                    |
|----|--------------------|
| 1. | NC                 |
| 2. | Inverting Input    |
| 3. | Noninverting Input |
| 4. | $V^-$              |
| 5. | NC                 |
| 6. | Output             |
| 7. | $V^+$              |
| 8. | NC                 |

ORDER PART NOS.  
LM107H/LM307H

#### V PACKAGE

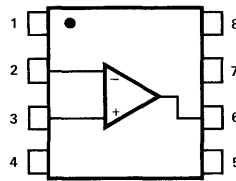

- |    |                    |
|----|--------------------|
| 1. | NC                 |
| 2. | Inverting Input    |
| 3. | Noninverting Input |
| 4. | $V^-$              |
| 5. | NC                 |
| 6. | Output             |
| 7. | $V^+$              |
| 8. | NC                 |

ORDER PART NO. LM307N

### EQUIVALENT SCHEMATIC

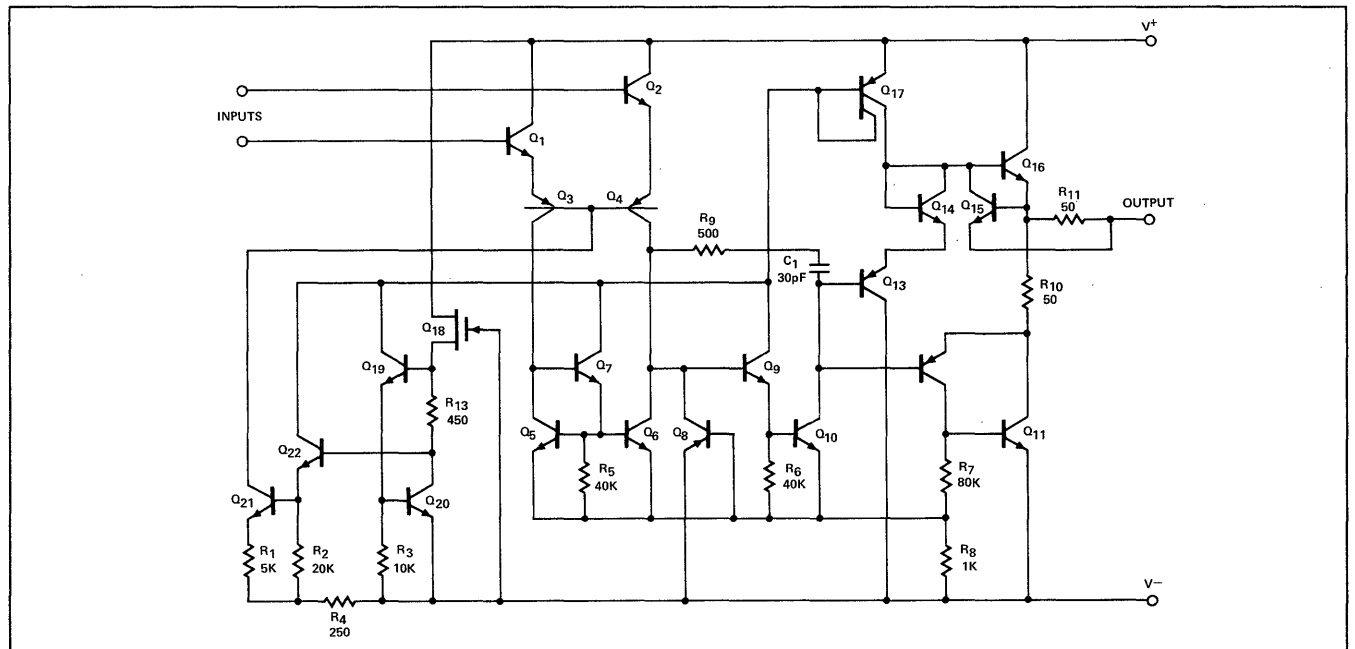

**SIGNETICS ■ LM107/307 – GENERAL PURPOSE OPERATIONAL AMPLIFIER**
**ELECTRICAL CHARACTERISTICS**

PARAMETER	CONDITIONS	LM107			LM307			UNITS
		MIN	TYP	MAX	MIN	TYP	MAX	
Input Offset Voltage	$T_A = 25^\circ\text{C}, R_S \leq 10\text{K}\Omega$	–	0.7	2.0	–	–	–	mV
	$T_A = 25^\circ\text{C}, R_S \leq 50\text{K}\Omega$	–	–	–	–	2.0	7.5	–
Input Offset Current	$T_A = 25^\circ\text{C}$	–	1.5	10	–	3	50	nA
Input Bias Current	$T_A = 25^\circ\text{C}$	–	30	75	–	70	250	nA
Input Resistance	$T_A = 25^\circ\text{C}$	1.5	4	–	0.5	2	–	M $\Omega$
Supply Current	$T_A = 25^\circ\text{C}, V_S = \pm 20\text{V}$	–	1.8	3.0	–	–	–	mA
	$T_A = 25^\circ\text{C}, V_S = \pm 15\text{V}$	–	–	–	–	1.8	3.0	mA
Large Signal Voltage Gain	$T_A = 25^\circ\text{C}, V_S = \pm 15\text{V}$ $V_{\text{OUT}} = \pm 10\text{V},$ $R_L \geq 2\text{K}\Omega$	50	160	–	25	160	–	V/mV
Input Offset Voltage	$R_S \leq 10\text{K}\Omega$	–	–	3.0	–	–	–	mV
	$R_S \leq 50\text{K}\Omega$	–	–	–	–	–	10	mV
Average Temperature Coefficient of Input Offset Voltage			3.0	15	–	6.0	30	$\mu\text{V}/^\circ\text{C}$
Input Offset Current		–	–	20	–	–	70	nA
Average Temperature Coefficient of Input Offset Current	$25^\circ\text{C} \leq T_A \leq 125^\circ\text{C}$	–	0.01	0.1	–	–	–	nA/ $^\circ\text{C}$
	$-55^\circ\text{C} \leq T_A \leq 25^\circ\text{C}$	–	0.02	0.2	–	–	–	nA/ $^\circ\text{C}$
Average Temperature Coefficient of Input Offset Current	$25^\circ\text{C} \leq T_A \leq 70^\circ\text{C}$	–	–	–	–	0.01	0.3	nA/ $^\circ\text{C}$
	$0^\circ\text{C} \leq T_A \leq 25^\circ\text{C}$	–	–	–	–	0.02	0.6	nA/ $^\circ\text{C}$
Input Bias Current		–	–	100	–	–	300	nA
Supply Current	$T_A = +125^\circ\text{C},$ $V_S = \pm 20\text{V}$	–	1.2	2.5	–	–	–	mA
Large Signal Voltage Gain	$V_S = \pm 15\text{V}, V_{\text{OUT}} =$ $\pm 10\text{V}, R_L \geq 2\text{K}\Omega$	25	–	–	15	–	–	V/mV
Output Voltage Swing	$V_S = \pm 15\text{V}, R_L = 10\text{K}\Omega$	$\pm 12$	$\pm 14$	–	$\pm 12$	$\pm 14$	–	V
	$R_L = 2\text{K}\Omega$	$\pm 10$	$\pm 13$	–	$\pm 10$	$\pm 13$	–	V
Input Voltage Range	$V_S = \pm 20\text{V}$	$\pm 15$	–	–	–	–	–	V
	$V_S = \pm 15\text{V}$	–	–	–	$\pm 12$	–	–	V
Common Mode Rejection Ratio	$R_S \leq 10\text{K}\Omega$	80	96	–	–	–	–	dB
	$R_S \leq 50\text{K}\Omega$	–	–	–	70	90	–	dB
Supply Voltage Rejection Ratio	$R_S \leq 10\text{K}\Omega$	80	96	–	–	–	–	dB
	$R_S \leq 50\text{K}\Omega$	–	–	–	70	96	–	dB

**NOTES:**

- For operating at elevated temperatures, the device must be derated based on a  $150^\circ\text{C}$  maximum junction temperature and a thermal resistance of  $150^\circ\text{C}/\text{W}$  junction to ambient or  $45^\circ\text{C}/\text{W}$  junction to case (for T Package).
- For supply voltages less than  $\pm 15\text{V}$ , the absolute maximum input voltage is equal to the supply voltage.
- Continuous short circuit is allowed for case temperatures to  $70^\circ\text{C}$  and ambient temperatures to  $55^\circ\text{C}$ .
- The specifications apply for  $-55^\circ\text{C}$  to  $125^\circ\text{C}$  for LM107 and  $0^\circ\text{C}$  to  $70^\circ\text{C}$  for LM307 unless otherwise specified.
- $\pm 5\text{V} \leq V_S \leq \pm 15\text{V}$  unless otherwise specified.

GUARANTEED PERFORMANCE CURVES

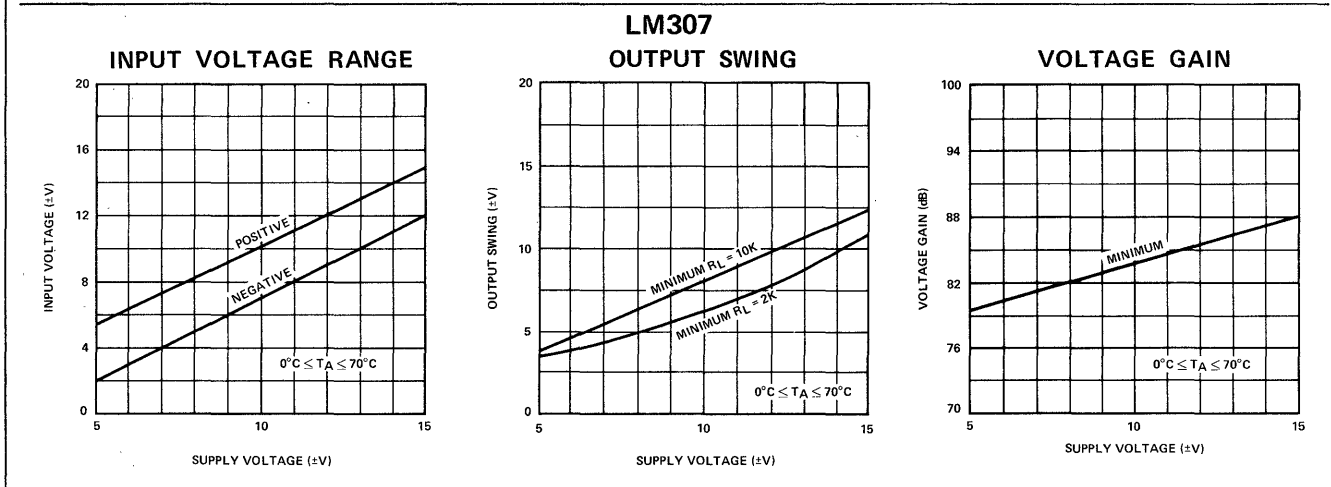
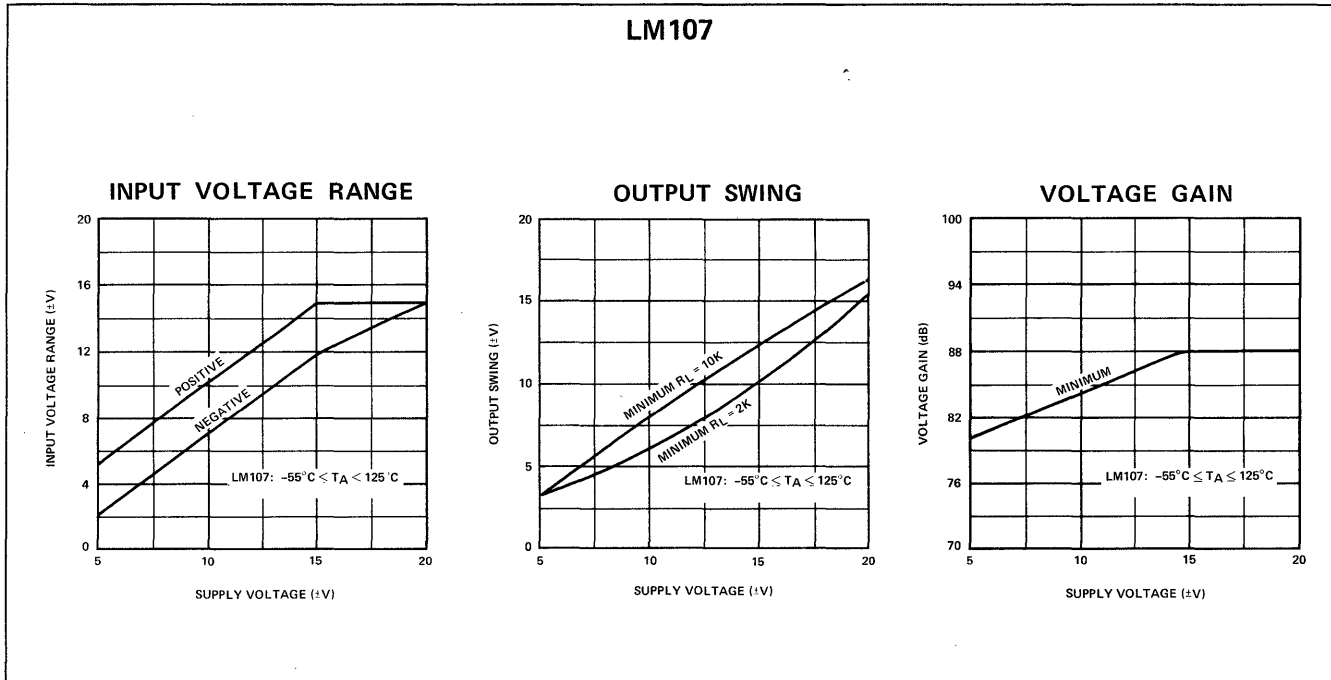

TYPICAL PERFORMANCE CURVES

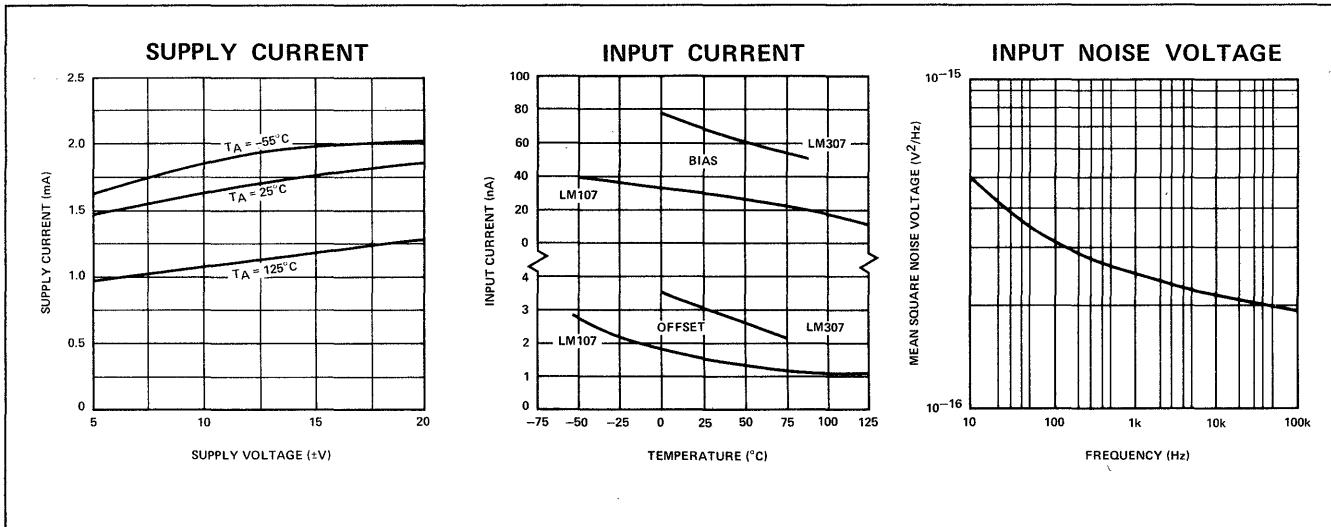

TYPICAL PERFORMANCE CURVES (cont'd)

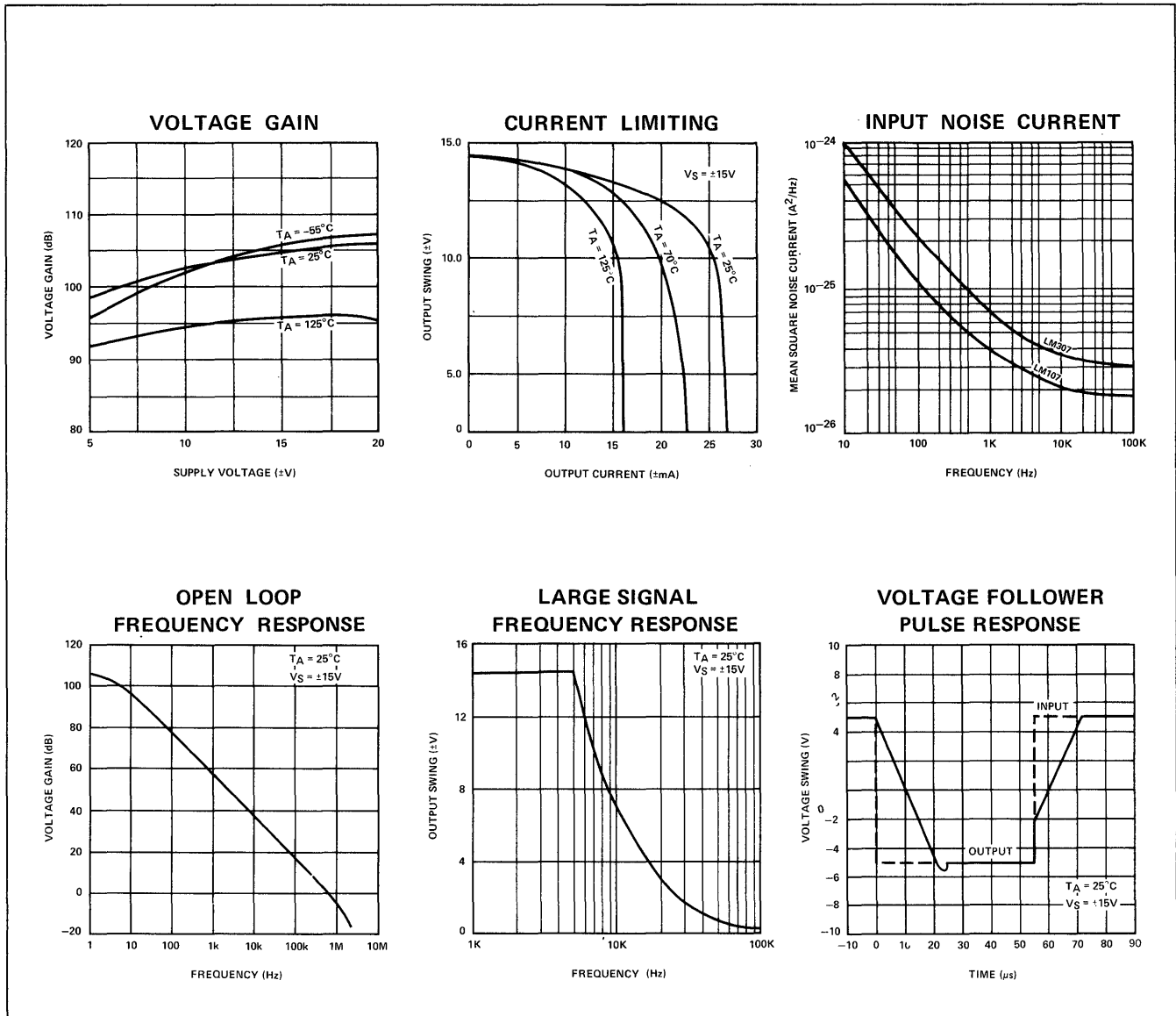

TYPICAL APPLICATIONS

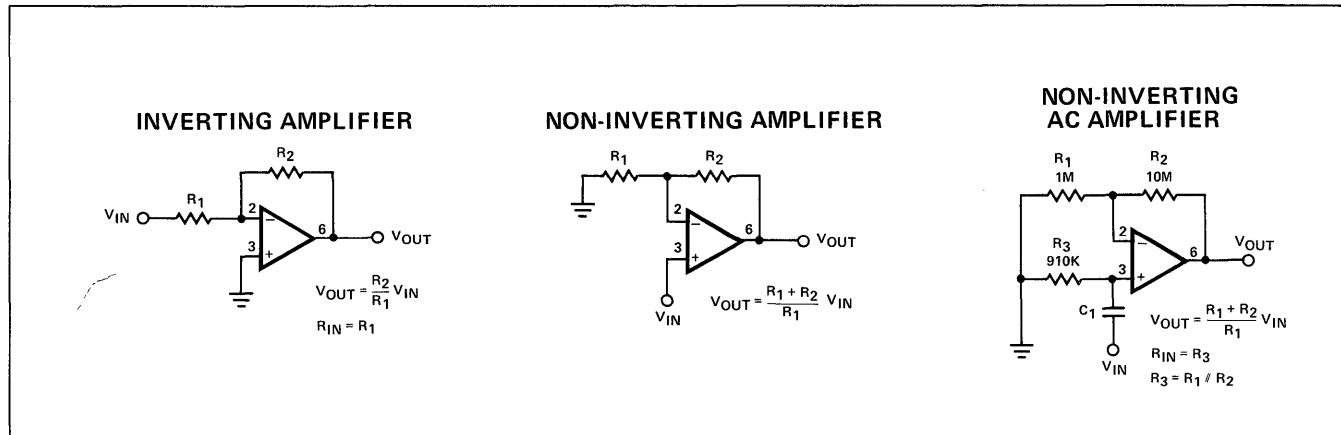

## LINEAR INTEGRATED CIRCUITS

### DESCRIPTION

The 5556 is an internally compensated precision monolithic operational amplifier featuring extremely low offset and bias currents and offset null capability. The 5556 is short circuit protected and its high common mode and differential input voltage range provides exceptional performance when used as an integrator, summing amplifier, and voltage follower.

The 5556 features industry standard pinout and is a direct pin-for-pin replacement for the MC15556G and MC14556G.

### ABSOLUTE MAXIMUM RATINGS

Power Supply Voltage

S5556	$\pm 22V$
N5556	$\pm 18V$

Differential Input Voltage  $\pm V^+$

Common Mode Input Voltage  $\pm V^+$

Load Current 20mA

Output Short Circuit Duration Indefinite

Power Dissipation 680mW

Derate Above  $T_A = 25^\circ C$   $4.6mW/^\circ C$

Operating Temperature Range

S5556	$-55^\circ C$ to $+125^\circ C$
N5556	$0^\circ C$ to $+70^\circ C$

Storage Temperature Range  $-65^\circ C$  to  $+150^\circ C$

### FEATURES

- LOW INPUT BIAS CURRENT - 15nA maximum
- LOW INPUT OFFSET CURRENT - 2.0nA maximum
- LOW INPUT OFFSET VOLTAGE - 4.0mV maximum
- HIGH SLEW RATE - 2.5 V/ $\mu s$  typical
- LARGE POWER BANDWIDTH - 40kHz typical
- LOW POWER CONSUMPTION - 45mW maximum
- OFFSET VOLTAGE NULL CAPABILITY

### PIN CONFIGURATIONS (Top View)

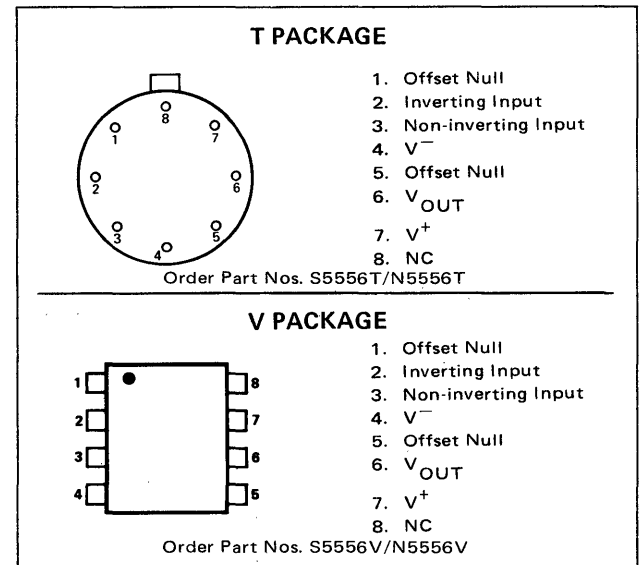

### EQUIVALENT CIRCUIT

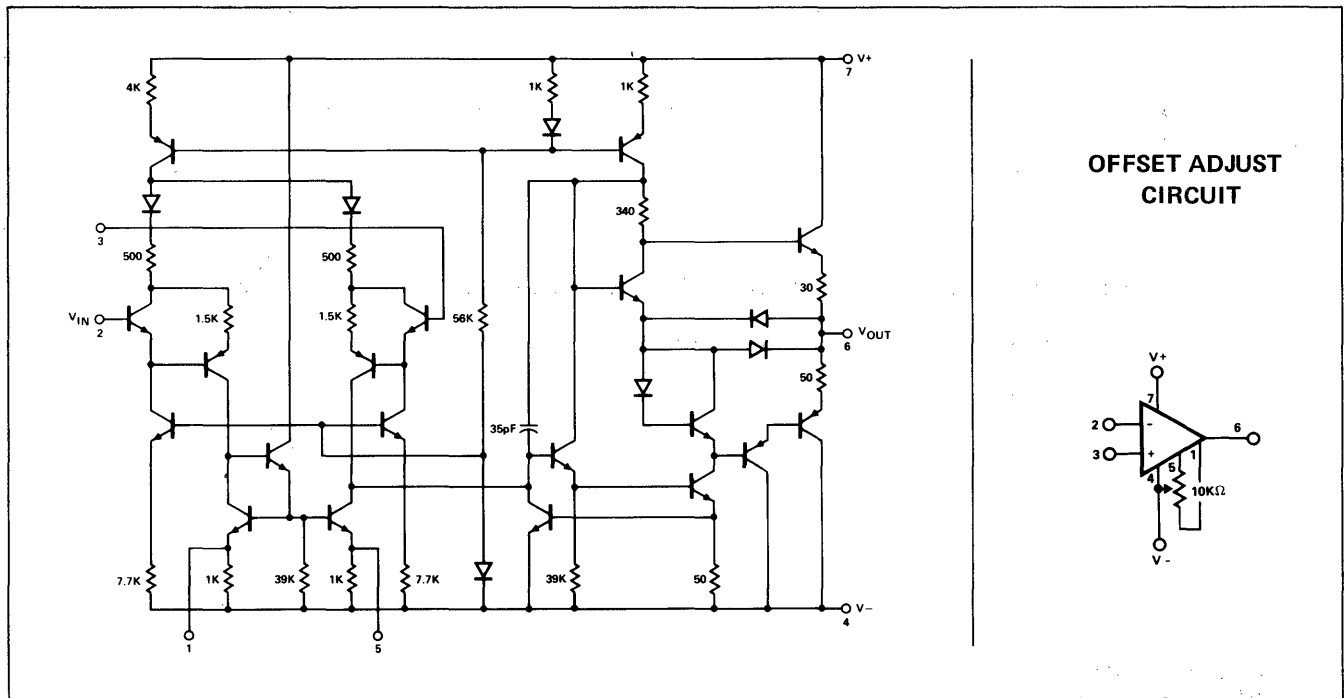

### OFFSET ADJUST CIRCUIT

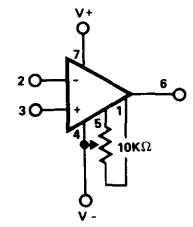

SIGNETICS ■ S/N 5556 – OPERATIONAL AMPLIFIER

ELECTRICAL CHARACTERISTICS ( $V^+ = +15V$ ,  $V^- = -15V$ ,  $T_A = +25^\circ C$  Unless Otherwise Noted)

PARAMETER	SYMBOL	MIN		TYP		MAX		UNITS
		S5556	N5556	S5556	N5556	S5556	N5556	
Input Bias Current $T_A = 25^\circ C$ $T_A = T_{LOW}$ to $T_{HIGH}$ (Note 1)	$I_B$			8	15	15 30	30 40	nA nA
Input Offset Current $T_A = 25^\circ C$ $T_A = 25^\circ C$ to $T_{High}$ $T_A = T_{LOW}$ to $25^\circ C$	$I_{io}$			1.0	5.0	2.0 3.0 5.0	10 14 14	nA nA nA
Input Offset Voltage $T_A = 25^\circ C$ $T_A = T_{LOW}$ to $T_{HIGH}$	$V_{io}$			2.0	5.0	4.0 6.0	10 14	mV mV
Differential Input Impedance (Open Loop— $f = 20Hz$ )								
Parallel Input Resistance	$R_p$			5.0	3.0			M
Parallel Input Capacitance	$C_p$			6.0	6.0			pF
Common Mode Input Impedance ( $f = 20Hz$ )	$Z_{IN}$			250	250			M
Common Mode Input Voltage Swing	$CMV_{IN}$	$\pm 12$	$\pm 11$	$\pm 13$	$\pm 12$			V
Equivalent Input Noise Voltage  ( $A_v = 100$ , $R_s = 10K\Omega$ , $F = 1.0KHz$ , $BW = 1.0Hz$ )	$E_{IN}$			45	45			$nV/\sqrt{Hz}$
Common Mode Rejection Ratio ( $f = 100Hz$ )	CMRR	80	70	110	110			dB
Open Loop Voltage Gain ( $V_{OUT} = \pm 10V$ , $R_L = 2K\Omega$ $T_A = 25^\circ C$ $T_A = T_{LOW}$ to $T_{HIGH}$ )	$AVO$	100K 40K	70K 40K	200K	100K			V/V V/V
Power Bandwidth $A_v = 1$ , $R_L = 2K\Omega$ , $THD \leq 5\%$ , $V_{OUT} = \pm 10V$ )	$P_{BW}$			40	40			KHz
Unity Gain Crossover Frequency (open-loop)				1.0	1.0			MHz
Phase Margin (open-loop, unity gain)				70	70			Degrees
Gain Margin				18	18			dB
Slew Rate (unity gain)	$dV_{OUT}/dt$			2.5	2.5			$V/\mu sec$
Output Impedance ( $f = 20Hz$ )	$Z_{OUT}$			1.0	1.0	2.0	2.5	$K\Omega$
Output Voltage Swing ( $R_L = 2K\Omega$ )	$V_{OUT}$	$\pm 12$	$\pm 11$	$\pm 13$	$\pm 12$			V
Power Supply Sensitivity $V^- = \text{Constant}$ , $R_S \leq 10K$ $V^+ = \text{Constant}$ , $R_S \leq 10K$	$S^+$ $S^-$			50 50	75 75	100 100	200 200	MV/V MV/V
Power Supply Current	$I_{D+}$ $I_{D-}$			1.0 1.0	1.3 1.3	1.5 1.5	3.0 3.0	mA mA
DC Quiescent Power Dissipation ( $V_{OUT} = 0$ )	$P_D$			30	40	45	90	mW

NOTE:

1.  $T_{LOW} = 0^\circ C$  for N5556,  $-55^\circ C$  for S5556;  $T_{HIGH} = 70^\circ C$  for N5556,  $125^\circ C$  for S5556

TYPICAL PERFORMANCE CHARACTERISTICS

POWER DISSIPATION VERSUS POWER SUPPLY VOLTAGE

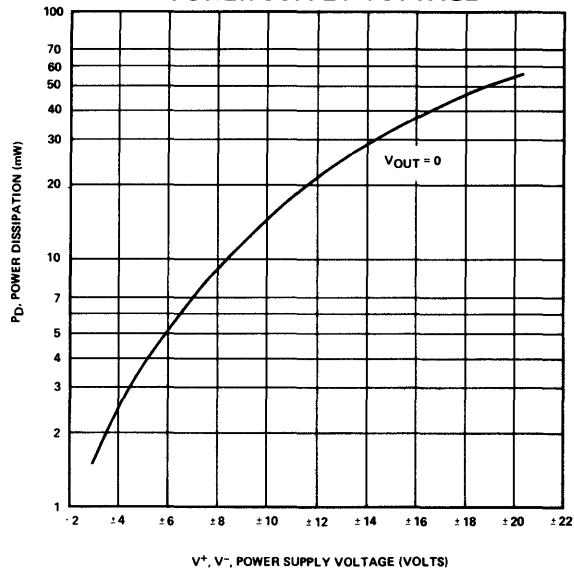

POWER BANDWIDTH

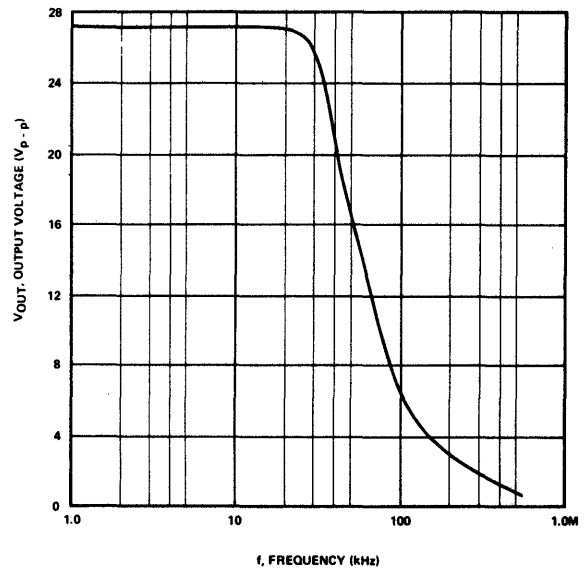

TYPICAL INPUT BIAS CURRENT AND INPUT OFFSET CURRENT VERSUS TEMPERATURE FOR S5556

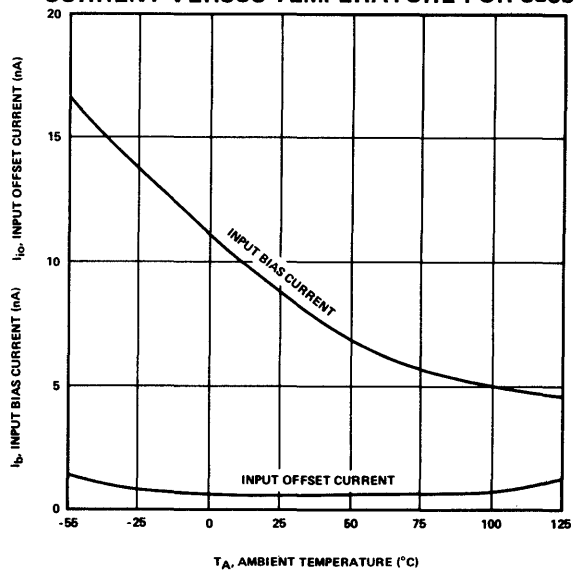

VOLTAGE-FOLLOWER PULSE RESPONSE

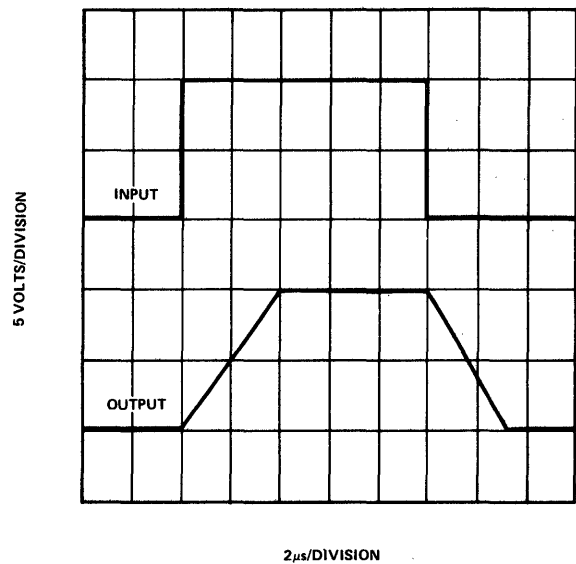





## LINEAR INTEGRATED CIRCUITS

### DESCRIPTION

The 5558 consists of a pair of high performance monolithic operational amplifiers constructed on a single chip. It features internal compensation and is intended for use in a variety of analog applications. High common mode voltage range and immunity to latch-up makes the 5558 ideal for use as a voltage follower. The high gain and wide range of operating voltage achieves superior performance in integrator, summing amplifier, and general feedback applications. The device is short-circuit protected. For single amplifier performance see the 5741 data sheet. The 5558 is a pin-for-pin replacement for the MC1558G.

### ABSOLUTE MAXIMUM RATINGS

Power Supply Voltages	
S5558	±22V
N5558	±18V
Differential Input Voltage	±30V
Common-mode Input Swing	±15V
Output Short Circuit Duration	Continuous
Power Dissipation (Note 1)	
T Package – (MO-002-AG)	680mW
Operating Temperature Range	
S5558	-55°C to +125°C
N5558	0°C to +75°C
Storage Temperature Range	-65°C to +150°C
Lead Temperature (Soldering, 60 sec)	300°C

**Note 1.** Derate linearly at 4.6 mW/°C for ambient temperatures above +25°C

### EQUIVALENT SCHEMATIC

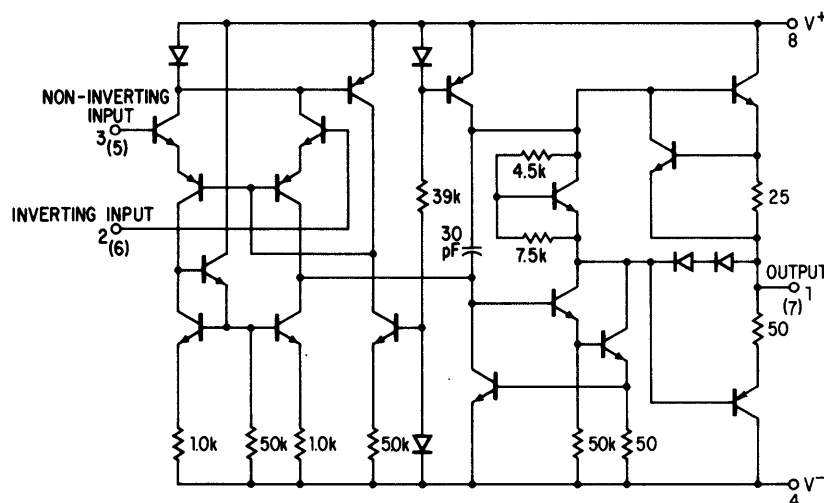

The numbers without parenthesis represent the pin numbers for 1/2 of the dual circuit. The numbers in parenthesis represent the pin numbers for the other half.

### PIN CONFIGURATIONS

#### T-PACKAGE (Top View)

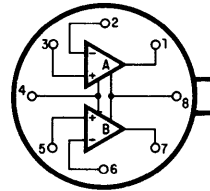

1. Output A
2. Inverting Input A
3. Noninverting Input A
4. V<sup>-</sup>
5. Noninverting Input B
6. Inverting Input B
7. Output B
8. V<sup>+</sup>

ORDER PART NOS. S5558T/N5558T

#### V-PACKAGE

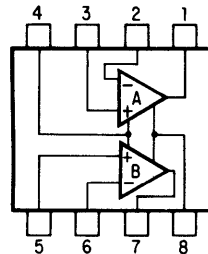

1. Output A
2. Inverting Input A
3. Noninverting Input A
4. V<sup>-</sup>
5. Noninverting Input B
6. Inverting Input B
7. Output B
8. V<sup>+</sup>

ORDER PART NO. N5558V

### FEATURES:

- "OP AMPS" IN SPACE OF ONE 5741A ("V" PACKAGE)
- NO FREQUENCY COMPENSATION REQUIRED
- SHORT CIRCUIT PROTECTION
- LOW POWER CONSUMPTION
- LARGE COMMON MODE AND DIFFERENTIAL VOLTAGE RANGES
- NO LATCH-UP

**SIGNETICS ■ 5558 – DUAL OPERATIONAL AMPLIFIER**

**ELECTRICAL CHARACTERISTICS ( $V^+ = +15\text{ Vdc}$ ,  $V^- = -15\text{ Vdc}$ ,  $T_A = +25^\circ\text{C}$  unless otherwise noted)**

CHARACTERISTICS	SYMBOL	MIN		TYP		MAX		UNIT
		S5558	N5558	S5558	N5558	S5558	N5558	
Input Bias Current $T_A = +25^\circ\text{C}$ $T_A = T_{low}$ to $T_{high}$ (See Note 1)	$I_b$			0.2	0.2	0.5 1.5	0.5 0.8	$\mu\text{A dc}$
Input Offset Current $T_A = +25^\circ\text{C}$ $T_A = T_{low}$ to $T_{high}$	$ I_{io} $			0.03	0.03	0.2 0.5	0.2 0.3	$\mu\text{A dc}$
Input Offset Voltage ( $R_S \leq 10\text{k}\Omega$ ) $T_A = +25^\circ\text{C}$ $T_A = T_{low}$ to $T_{high}$	$ V_{io} $			1.0	2.0	5.0 6.0	6.0 7.5	mVdc
Differential Input Impedance (Open-Loop, $f = 20\text{ Hz}$ )								
Parallel Input Resistance	$R_p$	0.3	0.3	1.0	1.0			Megohm
Parallel Input Capacitance	$C_p$			6.0	6.0			pF
Common-Mode Input Impedance ( $f = 20\text{ Hz}$ )	$Z_{(in)}$			200	200			Megohms
Common-Mode Input Voltage Swing	$CMV_{in}$	$\pm 12$	$\pm 12$	$\pm 13$	$\pm 13$			V <sub>pk</sub>
Equivalent Input Noise Voltage ( $A_V = 100$ , $R_S = \text{k}\Omega$ , $f = 1.0\text{ kHz}$ , $BW = 1.0\text{ Hz}$ )	$e_n$			45	45			nV(Hz) <sup>1/2</sup>
Common-Mode Rejection Ratio ( $f = 100\text{ Hz}$ )	$CM_{rej}$	70	70	90	90			dB
Open-Loop Voltage Gain, ( $V_{out} = \pm 10\text{ V}$ , $R_L = 2.0\text{k}\Omega$ ) $T_A = +25^\circ\text{C}$ $T_A = T_{low}$ to $T_{high}$	$AV_{OL}$	50,000 25,000	20,000 15,000	200,000	100,000			V/V
Power Bandwidth ( $A_V = 1$ , $R_L = 2.0\text{k}\Omega$ , $THD \leq 5\%$ , $V_{out} = 20\text{ V}_{p-p}$ )	PBW			14	14			kHz
Unity Gain Crossover Frequency (open-loop)				1.1	1.1			MHz
Phase Margin (open-loop, unity gain)				65	65			degrees
Gain Margin				11	11			dB
Slew Rate (Unity Gain)	$dV_{out}/dt$			0.8	0.8			V/ $\mu\text{s}$
Output Impedance ( $f = 20\text{ Hz}$ )	$Z_{out}$			300	300			ohms
Short-Circuit Output Current	$I_{SC}$			20	20			mA dc
Output Voltage Swing ( $R_L = 10\text{k}\Omega$ ) $R_L = 2\text{k}\Omega$ ( $T_A = T_{low}$ to $T_{high}$ )	$V_{out}$	$\pm 12$ $\pm 10$	$\pm 12$ $\pm 10$	$\pm 14$ $\pm 13$	$\pm 14$ $\pm 13$			V <sub>pk</sub>
Power Supply Sensitivity $V^- = \text{constant}$ , $R_S \leq 10\text{k}\Omega$ $V^+ = \text{constant}$ , $R_S \leq 10\text{k}\Omega$	$S^+$ $S^-$			30 30	30 30	150 150	150 150	$\mu\text{V/V}$
Power Supply Current	$I_{D^+}$ $I_{D^-}$			2.3 2.3	2.3 2.3	5.0 5.0	5.6 5.6	mA dc
DC Quiescent Power Dissipation ( $V_{out} = 0$ )	$P_D$			70	70	150	170	mW
Channel Separation	$e_{o1}/e_{o2}$			120	120			dB

Note 1:  $T_{low}$ :  $0^\circ\text{C}$  for N5558,  $-55^\circ\text{C}$  for S5558;  $T_{high}$ :  $+75^\circ\text{C}$  for N5558,  $+125^\circ\text{C}$  for S5558

**TYPICAL CHARACTERISTIC CURVES**

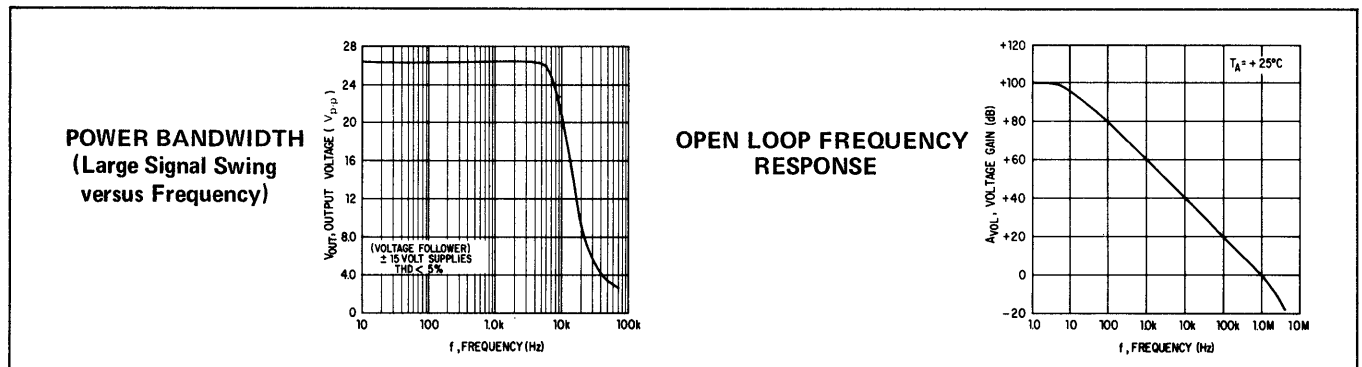

## LINEAR INTEGRATED CIRCUITS

### PIN CONFIGURATIONS

### DESCRIPTION

The  $\mu$ A709 is a high performance monolithic operational amplifier with differential inputs. High open loop gain, high input impedance, wide input common mode and output voltage ranges plus low temperature drift enable it to be used in many applications formerly satisfied only by discrete amplifiers.

### FEATURES

- OPEN LOOP VOLTAGE GAIN = 45,000
- OUTPUT VOLTAGE SWING =  $\pm 14V$
- INPUT COMMON MODE RANGE =  $\pm 10V$
- DIFFERENTIAL INPUT RESISTANCE =  $\mu$ A709 250k $\Omega$   
 $\mu$ A709C 400k $\Omega$

### ABSOLUTE MAXIMUM RATINGS

Supply Voltage	$\pm 18V$
Internal Power Dissipation (Note 1)	N5709 250 mW S5709 300 mW
Differential Input Voltage	$\pm 5.0V$
Input Voltage	$\pm 10V$
Open Short-Circuit Duration ( $T_A = 25^\circ C$ )	$-25^\circ C$
Storage Temperature Range	$-65^\circ C$ to $+150^\circ C$
Operating Temperature Range	$\mu$ A709C $0^\circ C$ to $+75^\circ C$ $\mu$ A709 $-55^\circ C$ to $+125^\circ C$
Lead Temperature (Soldering, 60 sec)	$300^\circ C$

### NOTE:

1. Rating applied for case temperatures to  $+125^\circ C$ ; derate linearly at 5.6mW/ $^\circ C$  for ambient temperatures above  $+95^\circ C$ .

### BASIC CIRCUIT SCHEMATIC

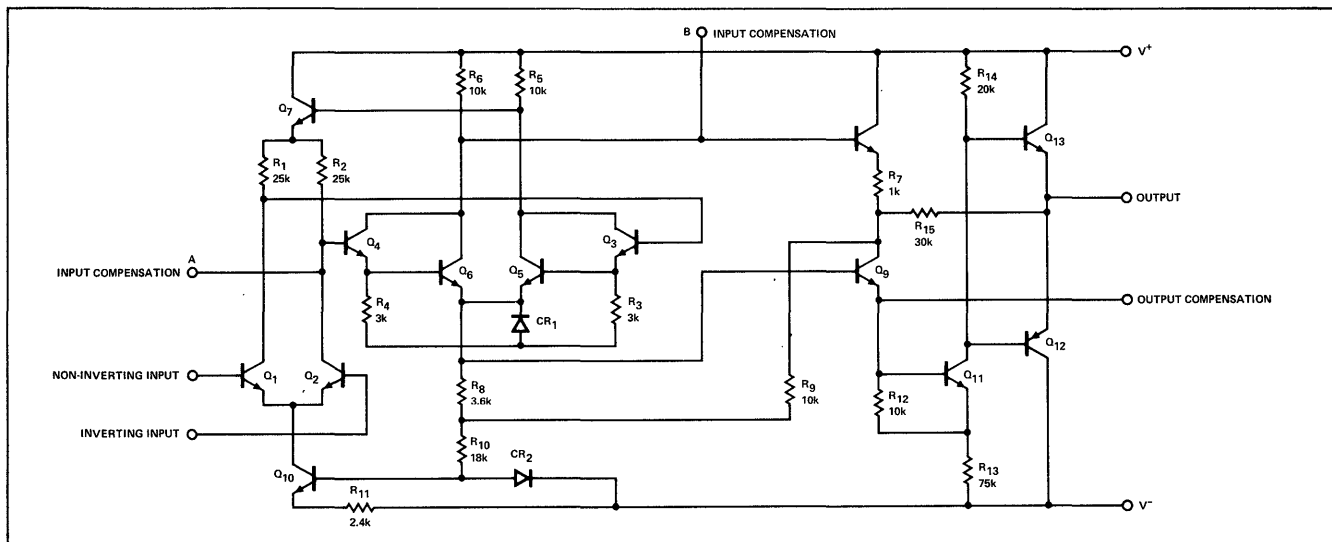

### A PACKAGE

(Top View)

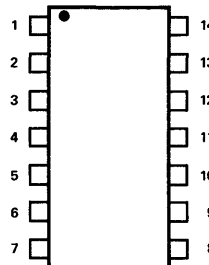

1. NC
2. NC
3. Input compensation A
4. Inverting input
5. Non-inverting input
6.  $V^-$
7. NC
8. NC
9. Output Compensation
10. Output
11.  $V^+$
12. Input compensation B
13. NC
14. NC

ORDER PART NOS.  
 $\mu$ A790A/ $\mu$ A709CA

### G PACKAGE

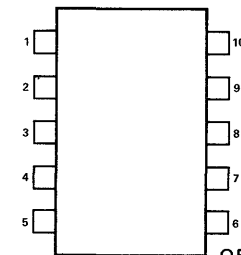

1. NC
2. Input compensation A
3. Inverting input
4. Non-inverting input
5.  $V^-$
6. Output compensation
7. Output
8.  $V^+$
9. Input compensation B
10. NC

ORDER PART NOS.  $\mu$ A709G/ $\mu$ A709CG

### T PACKAGE

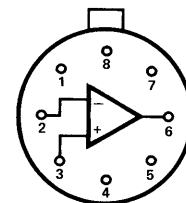

1. Input compensation A
2. Inverting input
3. Non-inverting input
4.  $V^-$
5. Output compensation
6. Output
7.  $V^+$
8. Input compensation B

ORDER PART NOS.  $\mu$ A709T/ $\mu$ A709CT

**SIGNETICS ■  $\mu$ A709 – OPERATIONAL AMPLIFIER**

**ELECTRICAL CHARACTERISTICS** ( $T_A = \pm 25^\circ\text{C}$ ,  $V_S = \pm 15\text{V}$  (709C);  $\pm 9 \leq V_S \leq \pm 15$  (709) unless otherwise specified)

PARAMETER	TEST CONDITIONS	$\mu$ A709			$\mu$ A709C			UNITS
		MIN.	TYP.	MAX.	MIN.	TYP.	MAX.	
<b>INPUT CHARACTERISTICS</b>								
Offset Voltage @ $25^\circ\text{C}$	$R_S \leq 10\text{K}\Omega$ , $+9\text{V} \leq V_S \leq +15\text{V}$		1	5		2	7.5	mV
Over Temperature	$R_S \leq 10\text{K}\Omega$ , $\pm 9\text{V} \leq \pm 15\text{V}$			6			10	mV
Offset Current @ $25^\circ\text{C}$			50	200		100	500	nA
Over Temperature	$T_A = +125^\circ\text{C}$		20	200				nA
	$T_A = -55^\circ\text{C}$		100	500				nA
	$0^\circ\text{C} \leq T_A \leq 75^\circ\text{C}$						750	nA
Bias Current @ $25^\circ\text{C}$			200	500		300	1500	nA
Over Temperature	$T_A = -55^\circ\text{C}$		0.5	1.5				$\mu\text{A}$
INPUT RESISTANCE @ $25^\circ\text{C}$		150	400		50	250		$\text{k}\Omega$
Over Temperature		40	100		35			$\text{k}\Omega$
INPUT VOLTAGE RANGE @ $25^\circ\text{C}$					$\pm 8.0$	$\pm 10$		V
Over Temperature	$V_S = \pm 15\text{V}$	$\pm 8.0$	$\pm 10$					V
<b>OUTPUT CHARACTERISTICS</b>								
Resistance @ $25^\circ\text{C}$			150			150		$\Omega$
Voltage Swing	$R_L \geq 10\text{K}\Omega$				$\pm 12$	$\pm 14$		V
	$R_L \geq 2\text{k}\Omega$				$\pm 10$	$\pm 13$		V
Over Temperature	$V_S = \pm 15\text{V}$ , $R_L \geq 10\text{K}\Omega$	$\pm 12$	$\pm 14$					V
	$V_S = \pm 15\text{V}$ , $R_L \geq 2\text{K}\Omega$	$\pm 10$	$\pm 13$					V
POWER CONSUMPTION	$V_S = +15\text{V}$		80	165		80	200	mW
<b>TRANSIENT RESPONSE</b> (Figure 1)								
Rise Time	$V_{in} = 10\text{mV}$ , $R_L = 2\text{K}\Omega$		0.3	1.0		0.3	1.0	$\mu\text{W}$
Overshoot	$C_L \leq 100\text{pF}$		10	30		10	30	%
LARGE SIGNAL VOLTAGE GAIN @ $25^\circ\text{C}$	$R_L \geq 25\text{K}\Omega$ , $V_{out} = \pm 10\text{V}$				15,000	45,000		V/V
Over Temperature	$R_L \geq 25\text{K}\Omega$ , $V_{out} = \pm 10\text{V}$	25,000	45,000	70,000	12,000			V/V
COMMON MODE REJECTION RATIO @ $25^\circ\text{C}$	$R_S \leq 10\text{K}\Omega$				65	90		dB
Over Temperature	$R_S \leq 10\text{K}\Omega$	70	90					dB
SUPPLY VOLTAGE REJECTION RATIO @ $25^\circ\text{C}$	$R_S \leq 10\text{K}\Omega$					25	200	mV/V
Over Temperature	$R_S \leq 10\text{K}\Omega$	25	150					$\mu\text{V}/\text{V}$
AVERAGE TEMPERATURE Coefficient of Input Offset Voltage	$R_S = 50\Omega$		3.0					$\mu\text{V}/^\circ\text{C}$
	$R_S \leq 10\text{K}\Omega$		6.0					$\mu\text{V}/^\circ\text{C}$

**TEST CIRCUIT**

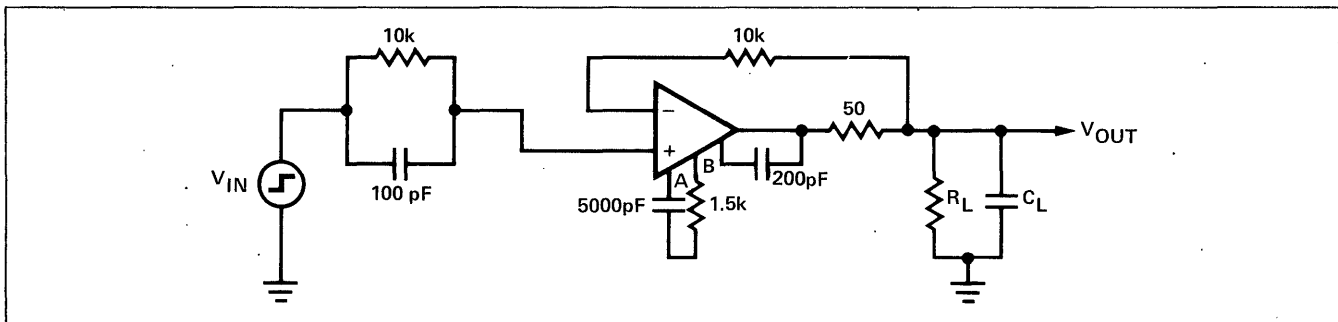

## DESCRIPTION

The  $\mu A740$  is a special purpose high performance operational amplifier utilizing a FET input stage for high input impedance and low input current.

The device features internal compensation, standard pinout, wide differential and common mode input voltage range, high slew rate and high output drive capability.

## FEATURES

- 0.1 nA INPUT BIAS CURRENT
- INPUT AND OUTPUT PROTECTION
- OFFSET NULL CAPABILITY
- INTERNALLY COMPENSATED
- 6V/ $\mu$ sec SLEW RATE
- STANDARD PINOUT
- NO LATCH UP

## ABSOLUTE MAXIMUM RATING

Supply Voltage	$\pm 22V$
Differential Input Voltage Range	$\pm 30V$
Common Mode Input Voltage Range	$\pm V_S$
Power Dissipation (Note 1)	500mW
Operating Temperature Range	$0^\circ C$ to $+70^\circ C$
Storage Temperature Range	$-65^\circ C$ to $+150^\circ C$
Lead Temperature (Solder, 60 sec)	$300^\circ C$
Output short Circuit Duration (Note 2)	Indefinite

1. Rating applies for case temperatures to  $+25^\circ V$ ; derate linearly at  $6.5mW/^\circ C$  for ambient temperatures above  $75^\circ C$ .
2. Short circuit may be to ground or either supply. Rating applies to  $+125^\circ C$  case temperature or  $+75^\circ C$  ambient temperature.

## EQUIVALENT CIRCUIT

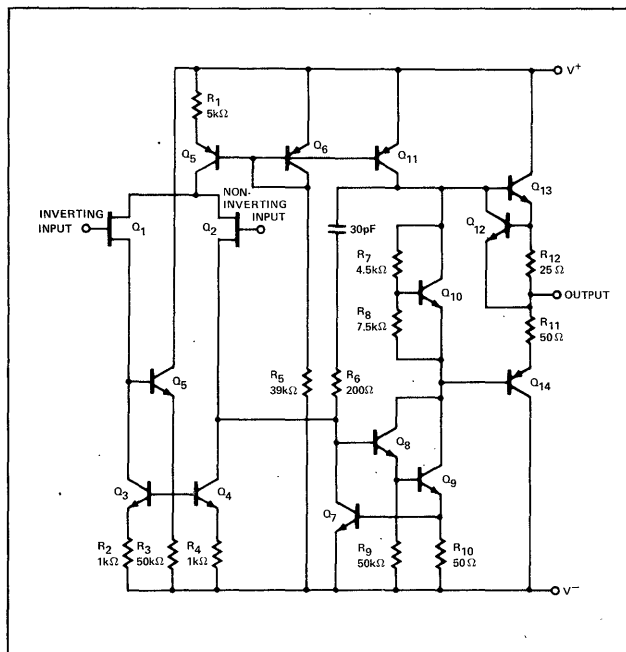

## LINEAR INTEGRATED CIRCUITS

### PIN CONFIGURATION (Top View)

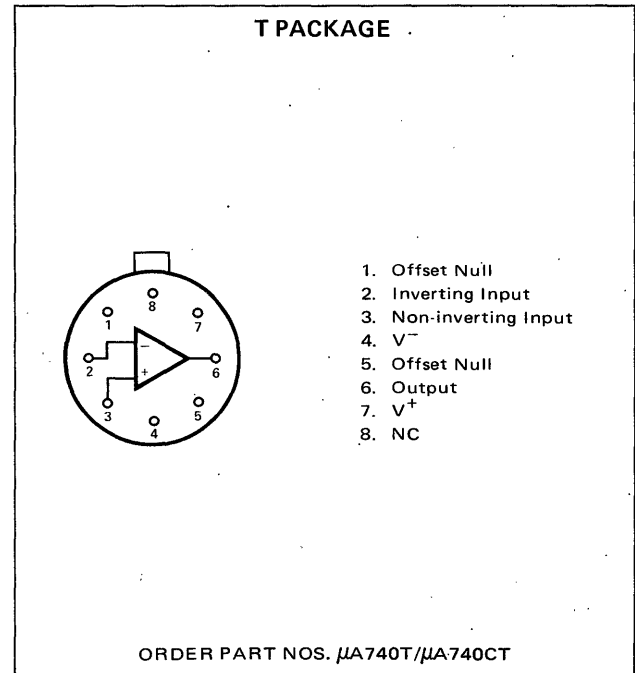

### TEST CIRCUITS

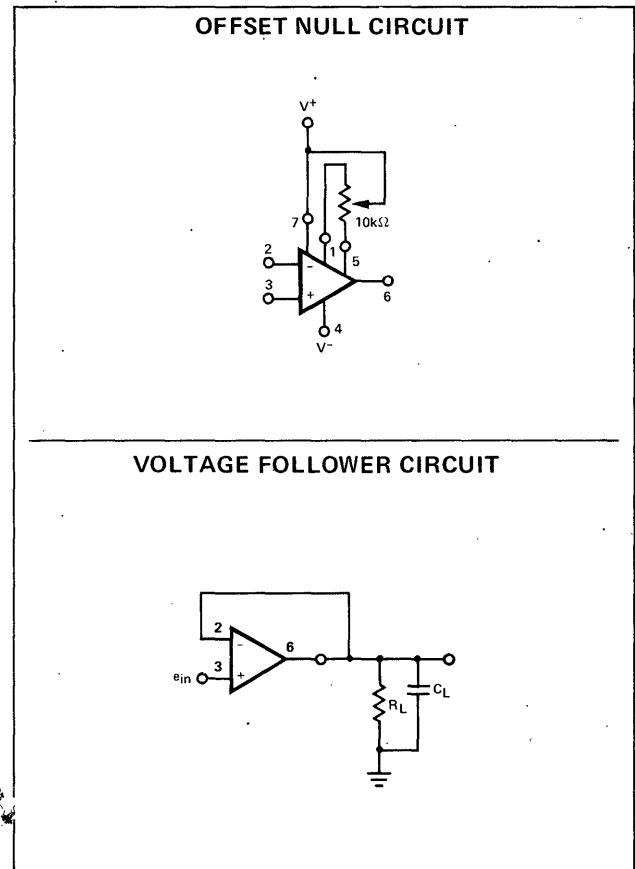

**SIGNETICS ■  $\mu$ A740 – FET OPERATIONAL AMPLIFIER**

**ELECTRICAL CHARACTERISTICS ( $V_S = \pm 15$  V,  $T_C = 25^\circ\text{C}$  unless otherwise specified)**

PARAMETER	TEST CONDITIONS	MIN	TYP	MAX	UNITS	
Input Offset Voltage	$R_S \leq 100\text{ k}\Omega$		30		mV	
Input Offset Current			60		pA	
Input Current (either input)			0.1	2.0	nA	
Input Resistance	$R_L \geq 2\text{ k}\Omega, V_{out} = \pm 10\text{V}$		1,000,000		M $\Omega$	
Large Signal Voltage Gain			1,000,000			
Output Resistance				75		$\Omega$
Output Short-Circuit Current				20		mA
Supply Current				4.2	3.0	mA
Power Consumption			126	240	mW	
Slew Rate			6.0		V/ $\mu$ s	
Unity Gain Bandwidth			1.0		MHz	
Transient Response (Unity Gain)	$C_L \leq 100\text{ pF}, R_L = 2\text{ k}\Omega, V_{in} = 100\text{ mV}$					
Risetime			300		ns	
Overshoot				10		%
The following specifications apply for $0^\circ\text{C} \leq T_A \leq +70^\circ\text{C}$						
Input Voltage Range			$\pm 12$		V	
Common Mode Rejection Ratio			80		db	
Supply Voltage Rejection Ratio			70		$\mu\text{V/V}$	
Large Signal Voltage Gain			500,000			
Output Voltage Swing	$R_L \geq 10\text{ k}\Omega$	$\pm 12$	$\pm 14$		V	
	$R_L \geq 2\text{ k}\Omega$	$\pm 10$	$\pm 13$		V	
Input Offset Voltage			30		mV	
Input Offset Current			60		pA	
Input Current (either input)			1.1	10	nA	

**TYPICAL CHARACTERISTIC CURVES**

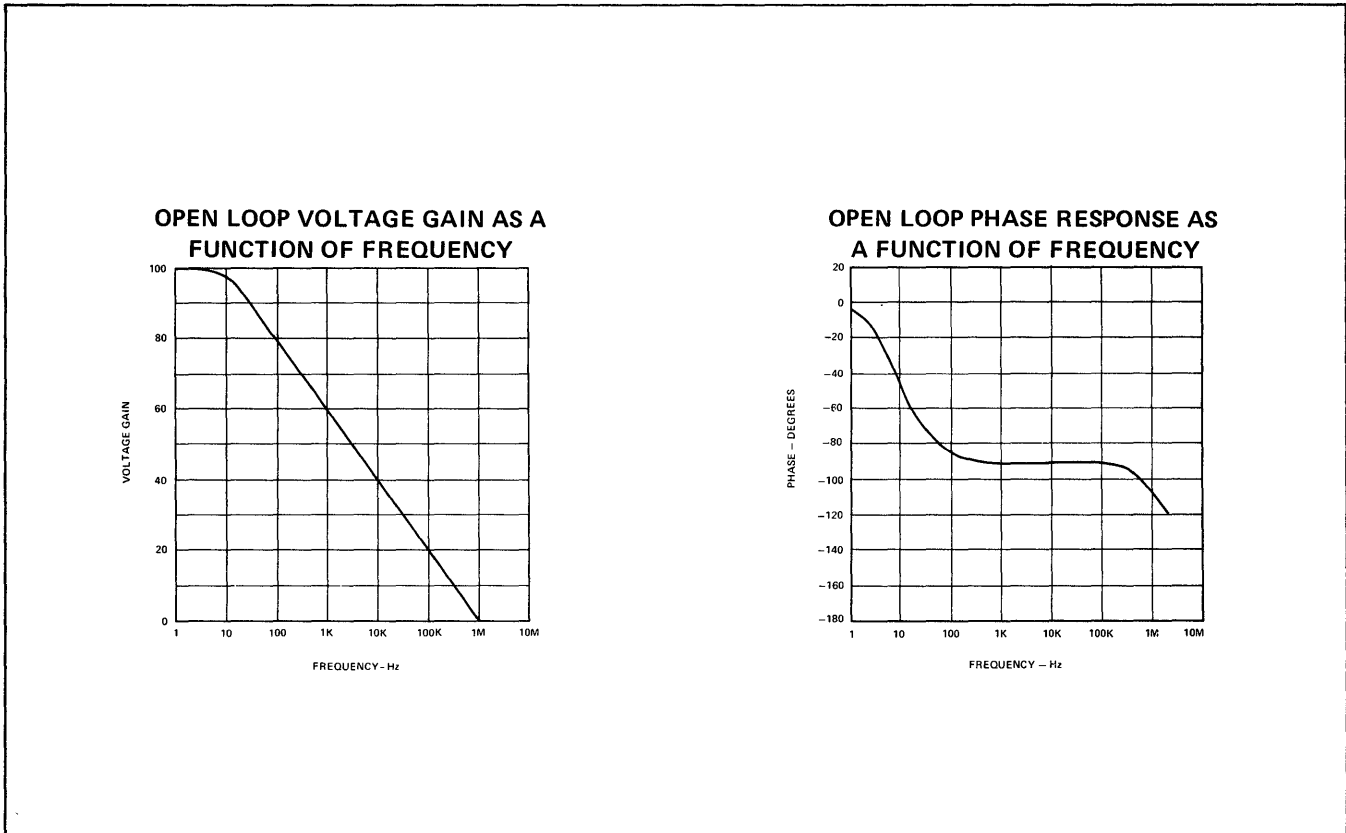

## LINEAR INTEGRATED CIRCUITS

### DESCRIPTION

The  $\mu A741$  is a high performance operational amplifier with high open loop gain, internal compensation, high common mode range and exceptional temperature stability. The  $\mu A741$  is short-circuit protected and allows for nulling of offset voltage.

### FEATURES

- INTERNAL FREQUENCY COMPENSATION
- SHORT CIRCUIT PROTECTION
- OFFSET VOLTAGE NULL CAPABILITY
- EXCELLENT TEMPERATURE STABILITY
- HIGH INPUT VOLTAGE RANGE
- NO LATCH-UP

### ABSOLUTE MAXIMUM RATINGS

	$\mu A741C$	$\mu A741$
Supply Voltage	$\pm 18V$	$\pm 22V$
Internal Power		
Dissipation (Note 1)	500mW	500mW
Differential Input Voltage	$\pm 30V$	$\pm 30V$
Input Voltage (Note 2)	$\pm 15V$	$\pm 15V$
Voltage between Offset Null and $V^-$	$\pm 0.5V$	$\pm 0.5V$
Operating Temperature		
Range	$0^\circ C$ to $+70^\circ C$	$-55^\circ C$ to $+125^\circ C$
Storage Temperature		
Range	$-65^\circ C$ to $+150^\circ C$	$-65^\circ C$ to $+150^\circ C$

Lead Temperature		
(Solder, 60 sec)	$300^\circ C$	$300^\circ C$
Output Short Circuit	Indefinite	Indefinite
Duration (Note 3)		

### Notes

1. Rating applies for case temperatures to  $125^\circ C$ ; derate linearly at  $6.5mW/^\circ C$  for ambient temperatures above  $+75^\circ C$ .
2. For supply voltages less than  $\pm 15V$ , the absolute maximum input voltage is equal to the supply voltage.
3. Short circuit may be to ground or either supply. Rating applies to  $+125^\circ C$  case temperature or  $+75^\circ C$  ambient temperature.

### EQUIVALENT CIRCUIT

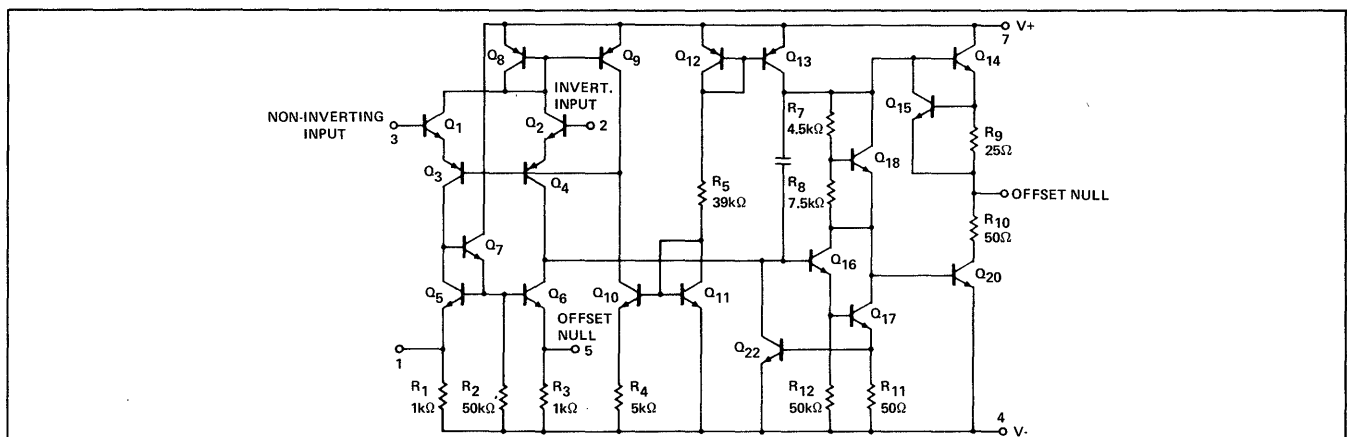

### PIN CONFIGURATIONS

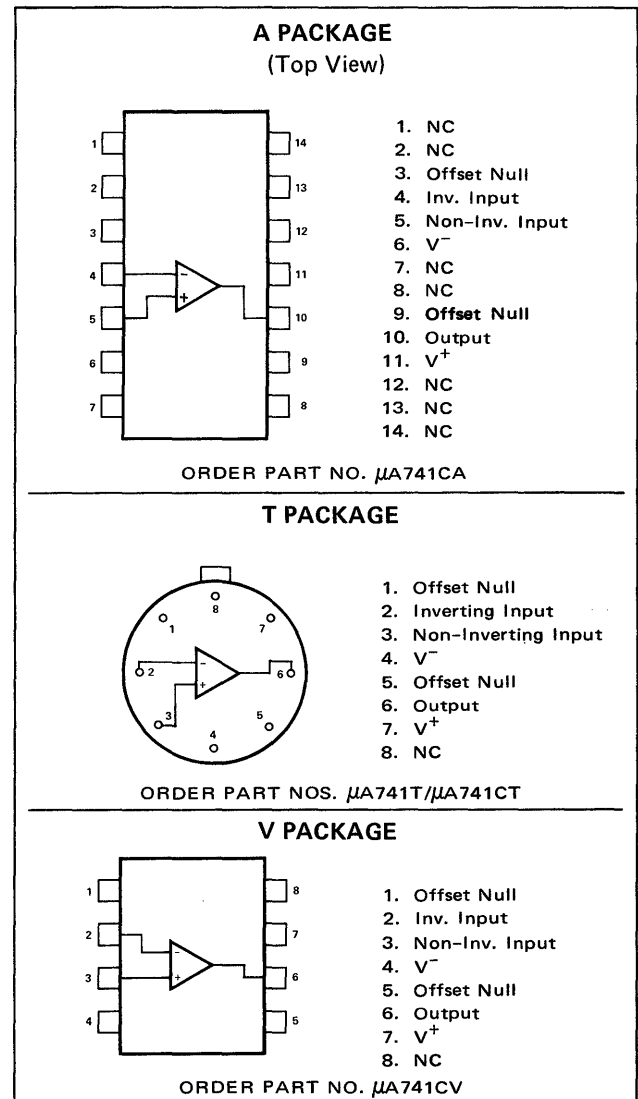



**SIGNETICS ■  $\mu$ A741 – HIGH PERFORMANCE OPERATIONAL AMPLIFIER**

**ELECTRICAL CHARACTERISTICS** ( $V_S = \pm 15V$ ,  $T_A = 25^\circ C$  unless otherwise specified)

PARAMETER	MIN.	TYP.	MAX.	UNITS	TEST CONDITIONS
<b><math>\mu</math>A741C</b>					
Input Offset Voltage		2.0	6.0	mV	$R_S \leq 10k\Omega$
Input Offset Current		20	200	nA	
Input Bias Current		80	500	nA	
Input Resistance	0.3	2.0		M $\Omega$	
Input Capacitance		~1.4		pF	
Offset Voltage Adjustment Range		$\pm 15$		mV	
Input Voltage Range	$\pm 12$	$\pm 13$		V	
Common Mode Rejection Ratio	70	90		dB	$R_S \leq 10k\Omega$
Supply Voltage Rejection Ratio		10	150	$\mu V/V$	$R_S \leq 10k\Omega$
Large-Signal Voltage Gain	20,000	200,000			$R_L \geq 2k\Omega$ , $V_{out} = \pm 10V$
Output Voltage Swing	$\pm 12$	$\pm 14$		V	$R_L \geq 10k\Omega$
	$\pm 10$	$\pm 13$		V	$R_L \geq 2k\Omega$
Output Resistance		75		$\Omega$	
Output Short-Circuit Current		25		mA	
Supply Current		1.4	2.8	mA	
Power Consumption		50	85	mW	
Transient Response (unity gain)					$V_{in} = 20mV$ , $R_L = 2k\Omega$ , $C_L \leq 100pF$
Risetime		0.3		$\mu s$	
Overshoot		5.0		%	
Slew Rate		0.5		V/ $\mu s$	$R_L \geq 2k\Omega$
The following specifications apply for $0^\circ C \leq T_A \leq +70^\circ C$					
Input Offset Voltage			7.5	mV	
Input Offset Current			300	nA	
Input Bias Current			800	nA	
Large-Signal Voltage Gain	15,000				$R_L \geq 2k\Omega$ , $V_{out} = \pm 10V$
Output Voltage Swing	$\pm 10$	$\pm 13$		V	$R_L \geq 2k\Omega$
<b><math>\mu</math>A741</b>					
Input Offset Voltage		1.0	5.0	mV	$R_S \leq 10k\Omega$
Input Offset Current		10	200	nA	
Input Bias Current		80	500	nA	
Input Resistance	0.3	2.0		M $\Omega$	
Input Capacitance		1.4		pF	
Offset Voltage Adjustment Range		$\pm 15$		mV	
Large-Signal Voltage Gain	50,000	200,000			$R_L \geq 2k\Omega$ , $V_{out} = \pm 10V$
Output Resistance		75		$\Omega$	
Output Short Circuit Current		25		mA	
Supply Current		1.4	2.8	mA	
Power Consumption		50	85	mW	
Transient Response (unity gain)					$V_{in} = 20mV$ , $R_L = 2k\Omega$ , $C_L \leq 100pF$
Risetime		0.3		$\mu s$	
Overshoot		5.0		%	
Slew Rate		0.5		V/ $\mu s$	$R_L \geq 2k\Omega$
The following specifications apply for $-55^\circ C \leq T_A \leq +125^\circ C$					
Input Offset Voltage		1.0	6.0	mV	$R_S \leq 10k\Omega$
Input Offset Current		7.0	200	nA	$T_A = +125^\circ C$
		20	500	nA	$T_A = -55^\circ C$
Input Bias Current		0.03	0.5	$\mu A$	$T_A = +125^\circ C$
		0.3	1.5	$\mu A$	$T_A = -55^\circ C$
Input Voltage Range	$\pm 12$	$\pm 13$		V	
Common Mode Rejection Ratio	70	90		dB	$R_S \leq 10k\Omega$
Supply Voltage Rejection Ratio		10	150	$\mu V/V$	$R_S \leq 10k\Omega$
Large-Signal Voltage Gain	25,000				$R_L \geq 2k\Omega$ , $V_{out} = \pm 10V$
Output Voltage Swing	$\pm 12$	$\pm 14$		V	$R_L \geq 10k\Omega$
	$\pm 10$	$\pm 13$		V	$R_L \geq 2k\Omega$
Supply Current		1.5	2.5	mA	$T_A = +125^\circ C$
		2.0	3.3	mA	$T_A = -55^\circ C$
Power Consumption		45	75	mW	$T_A = +125^\circ C$
		45	100	mW	$T_A = -55^\circ C$

TYPICAL CHARACTERISTIC CURVES

**OUTPUT VOLTAGE SWING AS A FUNCTION OF SUPPLY VOLTAGE**

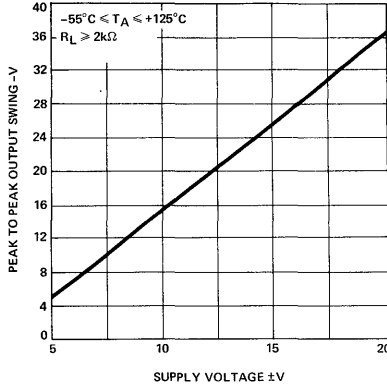

**INPUT COMMON MODE VOLTAGE RANGE AS A FUNCTION OF SUPPLY VOLTAGE**

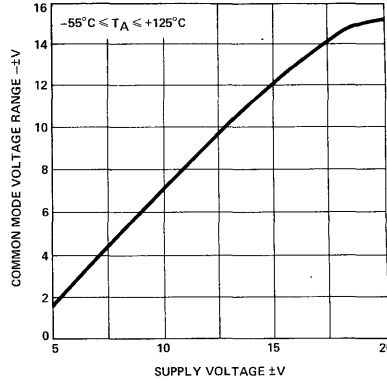

**POWER CONSUMPTION AS A FUNCTION OF SUPPLY VOLTAGE**

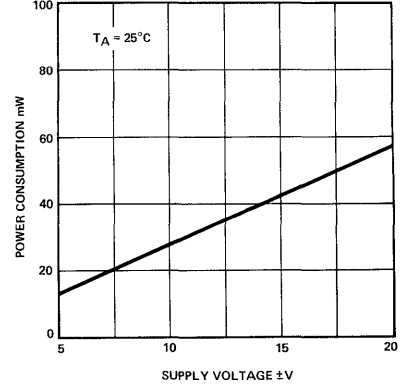

**INPUT BIAS CURRENT AS A FUNCTION OF AMBIENT TEMPERATURE**

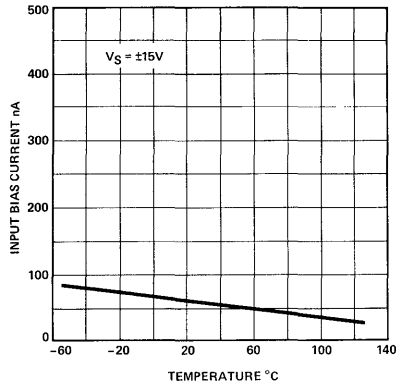

**INPUT RESISTANCE AS A FUNCTION OF AMBIENT TEMPERATURE**

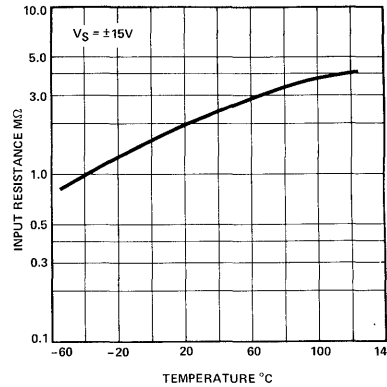

**INPUT OFFSET CURRENT AS A FUNCTION OF SUPPLY VOLTAGE**

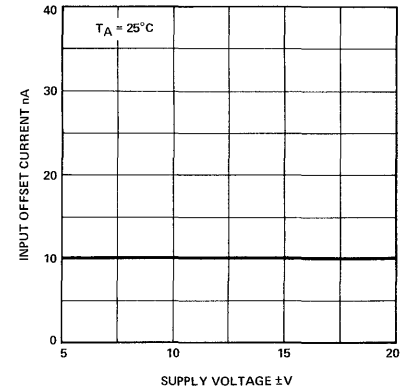

**INPUT OFFSET CURRENT AS A FUNCTION OF AMBIENT TEMPERATURE**

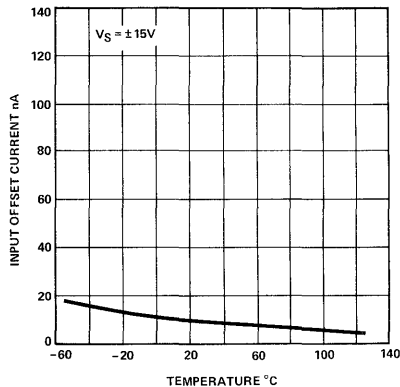

**POWER CONSUMPTION AS A FUNCTION OF AMBIENT TEMPERATURE**

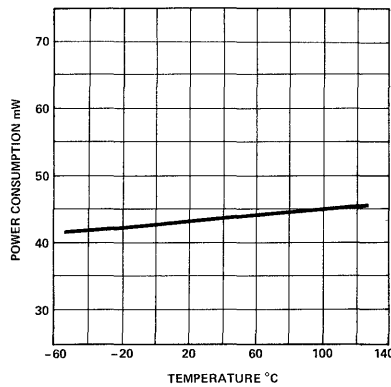

**OUTPUT VOLTAGE SWING AS A FUNCTION OF LOAD RESISTANCE**

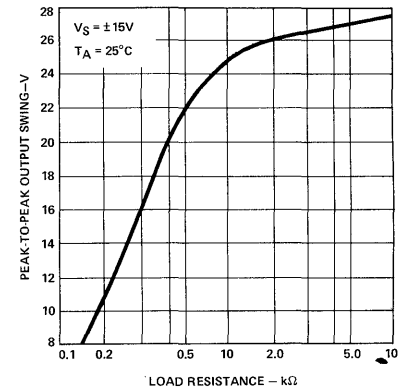

TYPICAL CHARACTERISTIC CURVES (Cont'd.)

**OUTPUT SHORT-CIRCUIT CURRENT AS A FUNCTION OF AMBIENT TEMPERATURE**

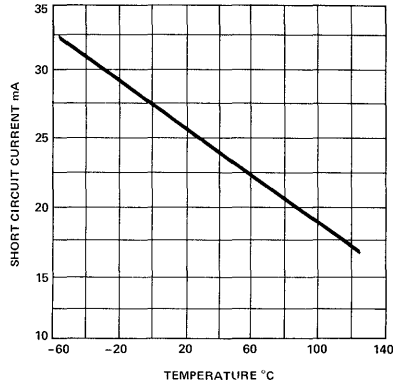

**INPUT NOISE VOLTAGE AS A FUNCTION OF FREQUENCY**

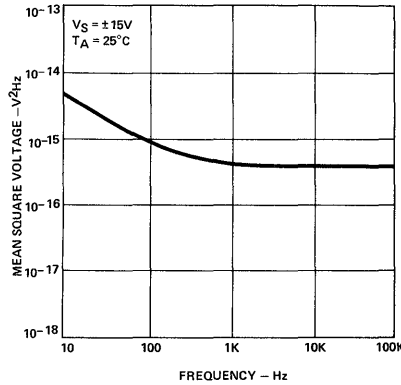

**INPUT NOISE CURRENT AS A FUNCTION OF FREQUENCY**

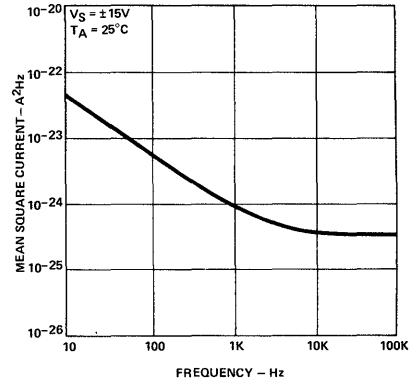

**BROADBAND NOISE FOR VARIOUS BANDWIDTHS**

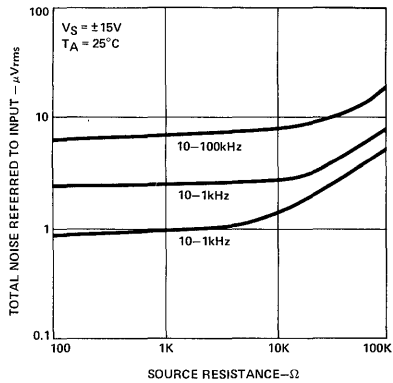

**OPEN LOOP VOLTAGE GAIN AS A FUNCTION OF FREQUENCY**

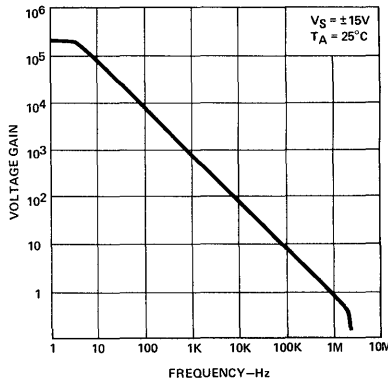

**OPEN LOOP PHASE RESPONSE AS A FUNCTION OF FREQUENCY**

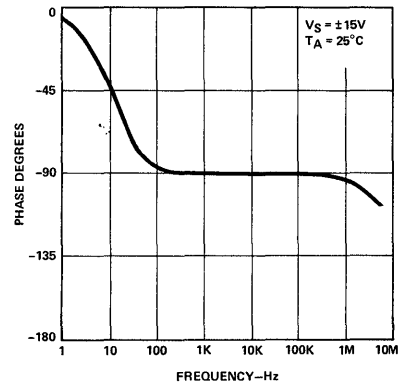

**OUTPUT VOLTAGE SWING AS A FUNCTION OF FREQUENCY**

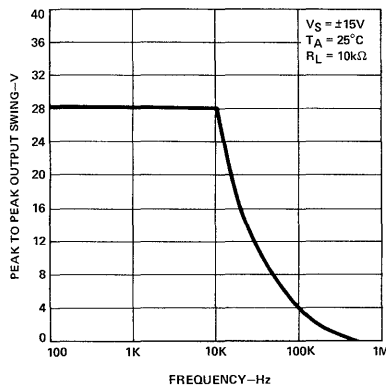

**COMMON MODE REJECTION RATIO AS A FUNCTION OF FREQUENCY**

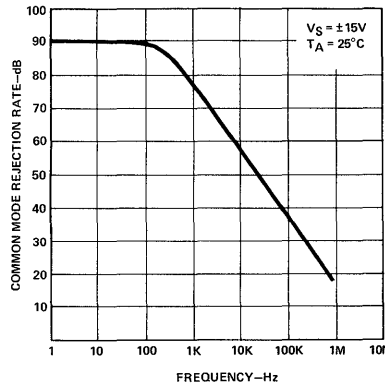

**TRANSIENT RESPONSE**

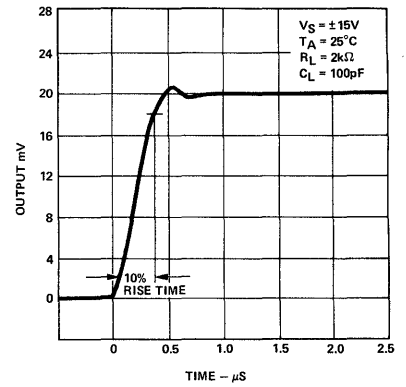

## DESCRIPTION

The  $\mu$ A747 is a pair of high performance monolithic operational amplifiers constructed on a single silicon chip. They are intended for a wide range of analog applications where board space or weight are important. High common mode voltage range and absence of "latch-up" make the  $\mu$ A747 ideal for use as a voltage follower. The high gain and wide range of operating voltage provides superior performance in integrator, summing amplifier, and general feedback applications. The  $\mu$ A747 is short-circuit protected and requires no external components for frequency compensation. The internal 6 db/octave roll-off insures stability in closed loop applications. For single amplifier performance, see  $\mu$ A741 data sheet.

## FEATURES

- NO FREQUENCY COMPENSATION REQUIRED
- SHORT-CIRCUIT PROTECTION
- OFFSET VOLTAGE NULL CAPABILITY
- LARGE COMMON-MODE AND DIFFERENTIAL VOLTAGE RANGES
- LOW POWER CONSUMPTION
- NO LATCH UP

## ABSOLUTE MAXIMUM RATINGS

Supply Voltage	A747	+22V
	A747C	+18V
Internal Power Dissipation (Note 1)	Metal Can	500 mW
	DIP	670 mW
Differential Input Voltage		+30V
Input Voltage (Note 2)		+15V
Voltage between Offset Null and $V^-$		+0.5V
Storage Temperature Range		-65°C to +155°C
Operating Temperature Range	A747	-55°C to +125°C
	A747C	0°C to +70°C
Lead Temperature (Soldering 60 seconds)		300°C
Output Short Circuit Duration (Note 3)		Indefinite

## LINEAR INTEGRATED CIRCUITS

### PIN CONFIGURATION

#### A PACKAGE

(Top View)

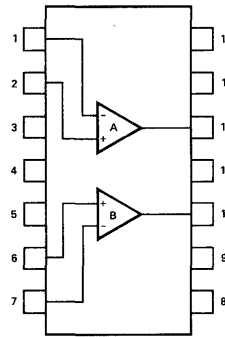

1. Inv Input A
2. Non-inv Input A
3. Offset Null A
4.  $V^-$
5. Offset Null B
6. Non-inv Input B
7. Inv Input B
8. Offset Null B
9.  $V^+$
10. Output B
11. No Connect
12. Output A
13.  $V^+$
14. Offset Null A

ORDER PART NOS.

$\mu$ A747A

$\mu$ A747CA

#### K PACKAGE

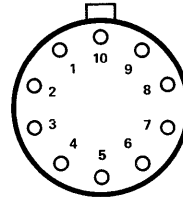

1. Output A
2.  $V^+$  A
3. Inverting Input A
4. Non-inverting Input A
5.  $V^-$
6. Non-inverting Input B
7. Inverting Input B
8.  $V^+$  B
9. Output B
10. NC

ORDER PART NOS.

$\mu$ A747K

$\mu$ A747CK

## EQUIVALENT CIRCUIT

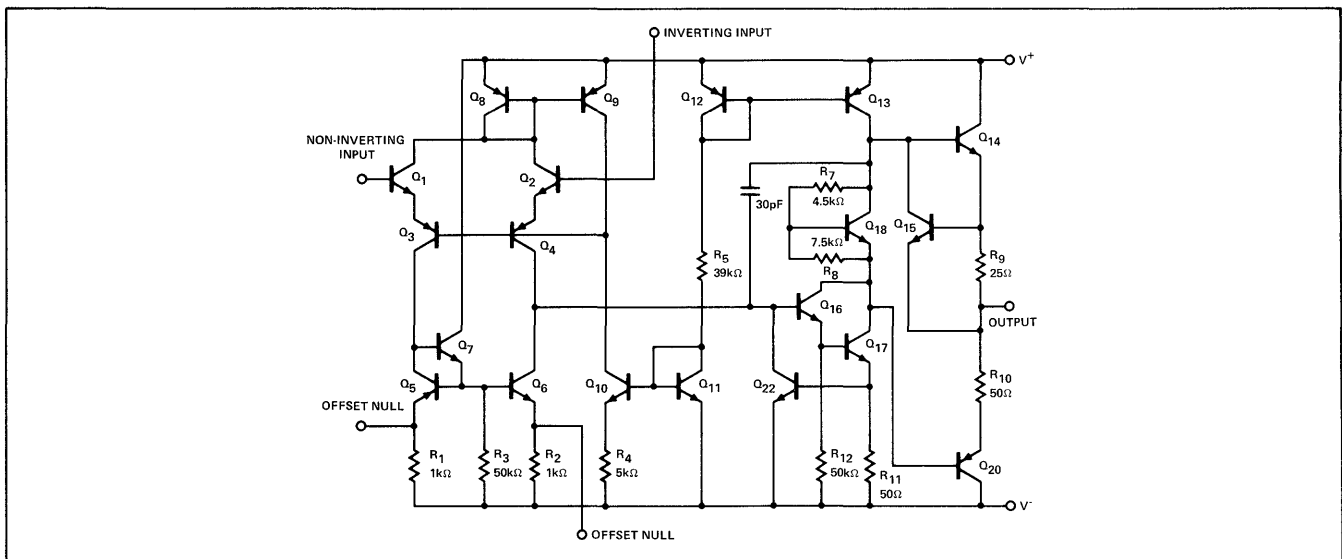

**SIGNETICS ■  $\mu$ A747 – DUAL OPERATIONAL AMPLIFIER**

**ELECTRICAL CHARACTERISTICS** ( $V_S = \pm 15\text{ V}$ ,  $T_A = 25^\circ\text{C}$  unless otherwise specified)

PARAMETERS	CONDITIONS	MIN.	TYP.	MAX.	UNITS
Input Offset Voltage	$R_S \leq 10\text{ k}\Omega$		1.0		mV
$\mu$ A747			5.0		mV
$\mu$ A747C			6.0		mV
Input Offset Current			20	200	nA
Input Bias Current			80	500	nA
Input Resistance		0.3	2.0		M $\Omega$
Input Capacitance			1.4		pF
Offset Voltage Adjustment Range			$\pm 15$		mV
Large-Signal Voltage Gain	$R_L \geq 2\text{ k}\Omega, V_{out} = \pm 10\text{ V}$		200,000		
$\mu$ A747		50,000			
$\mu$ A747C		25,000			
Output Resistance			75		$\Omega$
Output Short-Circuit Current			25		mA
Supply Current			1.7	2.8	mA
Power Consumption			50	85	mW
Transient Response (unity gain)	$V_{in} = 20\text{ mV}, R_L = 2\text{ k}\Omega, C_L \leq 100\text{ pF}$				
Risetime			0.3		$\mu$ s
Overshoot			5.0		%
Slew Rate	$R_L \geq 2\text{ k}\Omega$		0.5		V/ $\mu$ s
Channel Separation			120		dB

**$\mu$ A747 ONLY**

The following specifications apply for  $-55^\circ\text{C} \leq T_A \leq +125^\circ\text{C}$

Input Offset Voltage	$R_S \leq 10\text{ k}\Omega$		1.0	6.0	mV
Input Offset Current	$T_A = +125^\circ\text{C}$		7.0	200	nA
	$T_A = -55^\circ\text{C}$		85	500	nA
Input Bias Current	$T_A = +125^\circ\text{C}$		0.03	0.5	$\mu$ A
	$T_A = -55^\circ\text{C}$		0.3	1.5	$\mu$ A
Input Voltage Range		$\pm 12$	$\pm 13$		V
Common Mode Rejection Ratio	$R_S \leq 10\text{ k}\Omega$	70	90		dB
Supply Voltage Rejection Ratio	$R_S \leq 10\text{ k}\Omega$		30	150	$\mu$ V/V
Large-Signal Voltage Gain	$R_L \geq 2\text{ k}\Omega, V_{out} = \pm 10\text{ V}$	25,000			
Output Voltage Swing	$R_L \geq 10\text{ k}\Omega$	$\pm 12$	$\pm 14$		V
	$R_L \geq 2\text{ k}\Omega$	$\pm 10$	$\pm 13$		V
Supply Current	$T_A = +125^\circ\text{C}$		1.5	2.5	mA
	$T_A = -55^\circ\text{C}$		2.0	3.3	mA
Power Consumption	$T_A = +125^\circ\text{C}$		45	75	mW
	$T_A = -55^\circ\text{C}$		60	100	mW

**$\mu$ A747C**

The following specifications apply for  $0^\circ\text{C} \leq T_A \leq +70^\circ\text{C}$

Input Offset Voltage	$R_S \leq 10\text{ k}\Omega$		1.0	7.5	mV
Input Offset Current			7.0	300	nA
Input Bias Current			0.03	0.8	$\mu$ A
Input Voltage Range		$\pm 12$	$\pm 13$		V
Common Mode Rejection Ratio	$R_S \leq 10\text{ k}\Omega$	70	90		dB
Supply Voltage Rejection Ratio	$R_S \leq 10\text{ k}\Omega$		30	150	$\mu$ V/V
Large-Signal Voltage Gain	$R_L \geq 2\text{ k}\Omega, V_{out} = \pm 10\text{ V}$	15,000			
Output Voltage Swing	$R_L \geq 10\text{ k}\Omega$	$\pm 12$	$\pm 14$		V
	$R_L \geq 2\text{ k}\Omega$	$\pm 10$	$\pm 13$		V
Supply Current			2.0	3.3	mA
Power Consumption			60	100	mW

**NOTES:**

- Rating applied to ambient temperatures up to  $70^\circ\text{C}$  ambient derate linearly at  $6.3\text{ mW}/^\circ\text{C}$  for the Metal Can and  $8.3\text{ mW}/^\circ\text{C}$  for the Ceramic DIP package.
- For supply voltages less than  $+15\text{ V}$ , the absolute maximum input voltage is equal to the supply voltage.
- Short circuit may be to ground or either supply. Military rating applies to  $+125^\circ\text{C}$  case temperature or  $+60^\circ\text{C}$  ambient temperature for each side.

TYPICAL CHARACTERISTIC CURVES

OPEN LOOP VOLTAGE GAIN AS A FUNCTION OF FREQUENCY

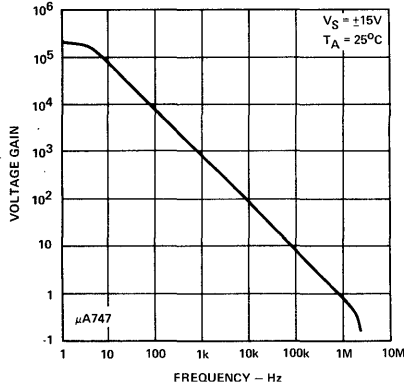

OPEN LOOP PHASE RESPONSE AS A FUNCTION OF FREQUENCY

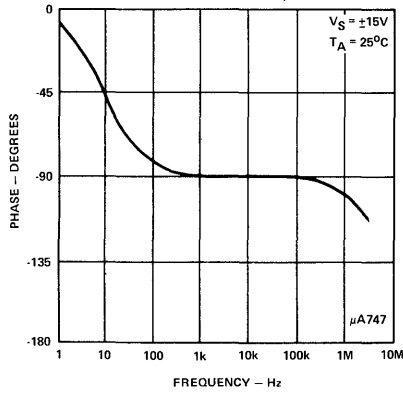

OUTPUT VOLTAGE SWING AS A FUNCTION OF FREQUENCY

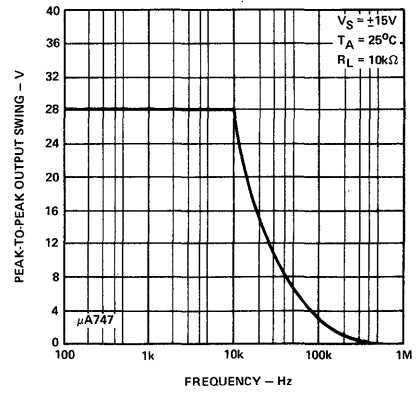

OPEN LOOP VOLTAGE GAIN AS A FUNCTION OF SUPPLY VOLTAGE

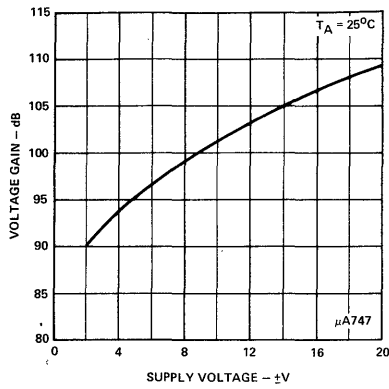

OUTPUT VOLTAGE SWING AS A FUNCTION OF SUPPLY VOLTAGE

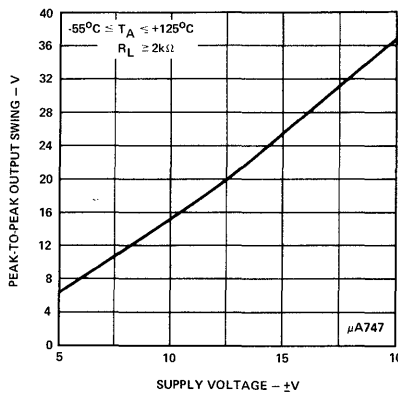

INPUT COMMON MODE VOLTAGE RANGE AS A FUNCTION OF SUPPLY VOLTAGE

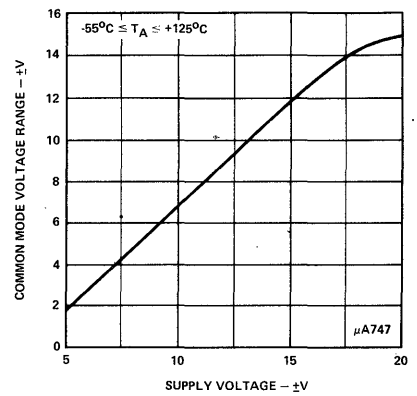

TRANSIENT RESPONSE

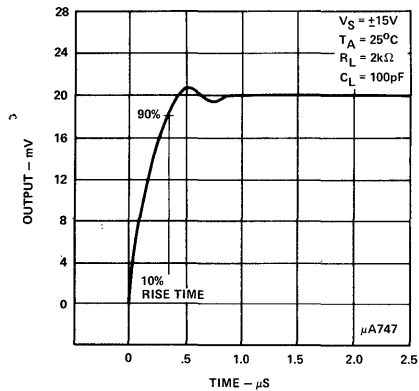

VOLTAGE FOLLOWER LARGE-SIGNAL PULSE RESPONSE

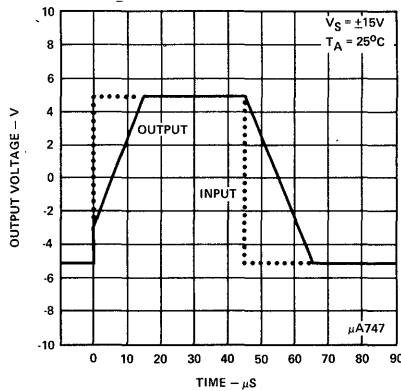

FREQUENCY CHARACTERISTICS AS A FUNCTION OF SUPPLY VOLTAGE

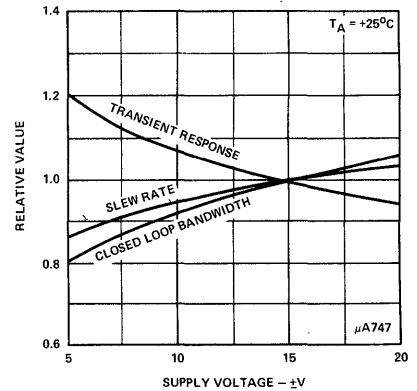

TYPICAL CHARACTERISTIC CURVES (Cont'd.)

**FREQUENCY CHARACTERISTICS AS A FUNCTION OF AMBIENT TEMPERATURE**

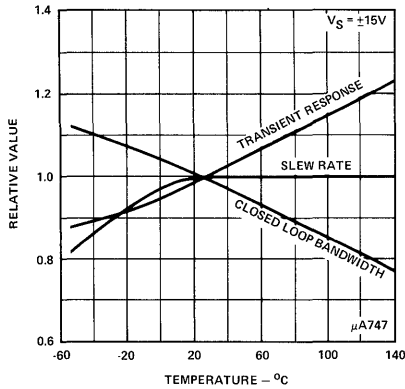

**POWER CONSUMPTION AS A FUNCTION OF SUPPLY VOLTAGE**

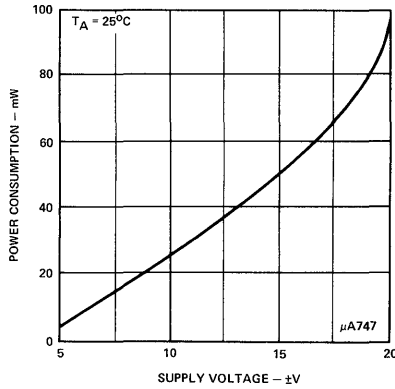

**INPUT BIAS CURRENT AS A FUNCTION OF AMBIENT TEMPERATURE**

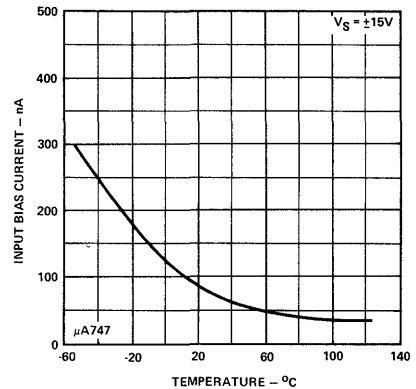

**INPUT RESISTANCE AS A FUNCTION OF AMBIENT TEMPERATURE**

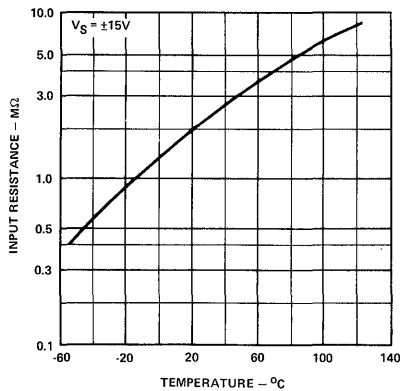

**INPUT OFFSET CURRENT AS A FUNCTION OF SUPPLY VOLTAGE**

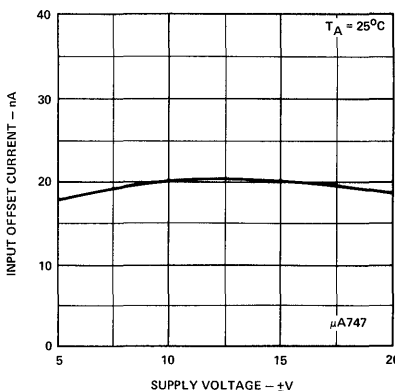

**INPUT OFFSET CURRENT AS A FUNCTION OF AMBIENT TEMPERATURE**

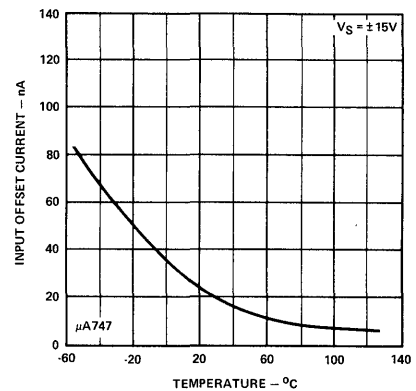

**POWER CONSUMPTION AS A FUNCTION OF AMBIENT TEMPERATURE**

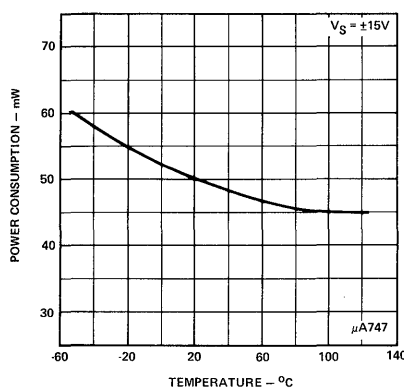

**OUTPUT VOLTAGE SWING AS A FUNCTION OF LOAD RESISTANCE**

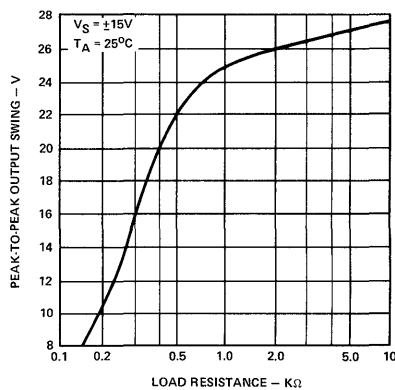

**OUTPUT SHORT-CIRCUIT CURRENT AS A FUNCTION OF AMBIENT TEMPERATURE**

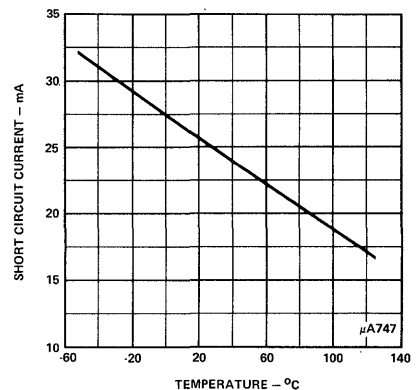

TYPICAL CHARACTERISTIC CURVES (Cont'd.)

**ABSOLUTE MAXIMUM POWER DISSIPATION AS A FUNCTION OF AMBIENT TEMPERATURE**

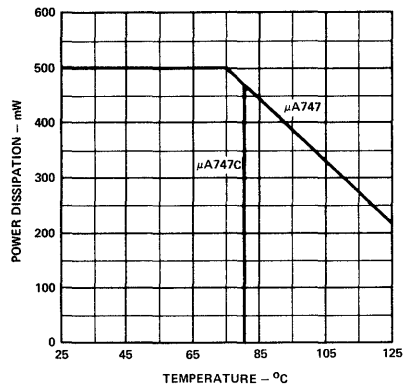

**INPUT NOISE VOLTAGE AS A FUNCTION OF FREQUENCY**

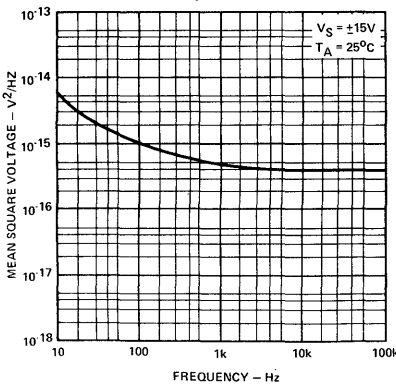

**INPUT NOISE CURRENT AS A FUNCTION OF FREQUENCY**

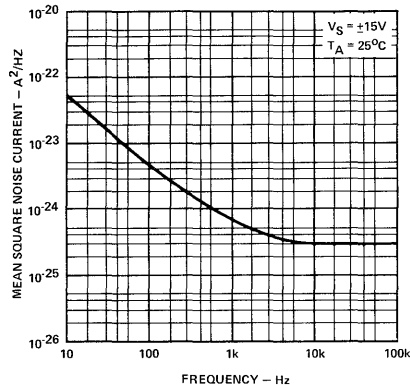

**BROADBAND NOISE FOR VARIOUS BANDWIDTHS**

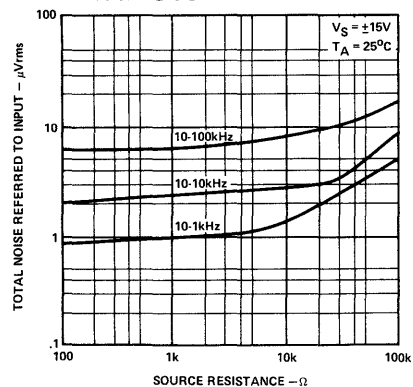

**TRANSIENT RESPONSE TEST CIRCUIT**

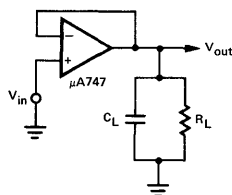

**VOLTAGE OFFSET NULL CIRCUIT**

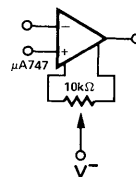





## LINEAR INTEGRATED CIRCUITS

### DESCRIPTION

The  $\mu$ A748 is a High Performance Operational Amplifier featuring high gain, short circuit immunity, offset voltage null capability, simplified compensation and excellent temperature stability.

### FEATURES

- SHORT CIRCUIT PROTECTION
- OFFSET VOLTAGE NULL CAPABILITY
- LARGE COMMON-MODE AND DIFFERENTIAL VOLTAGE RANGES
- LOW POWER CONSUMPTION
- NO LATCH UP

### ABSOLUTE MAXIMUM RATINGS:

Supply Voltage	
$\mu$ A748	$\pm 22V$
$\mu$ A748C	$\pm 18V$
Internal Power Dissipation (Note 1)	500mW
Differential Input Voltage	$\pm 30V$
Input Voltage (Note 2)	$\pm 15V$
Storage Temperature Range	$-65^{\circ}C$ to $+150^{\circ}C$
Operating Temperature Range	
$\mu$ A748	$-55^{\circ}C$ to $+125^{\circ}C$
$\mu$ A748C	$0^{\circ}C$ to $+70^{\circ}C$
Lead Temperature	$300^{\circ}C$
Output Short Circuit Duration (Note 3)	Indefinite

### EQUIVALENT CIRCUIT

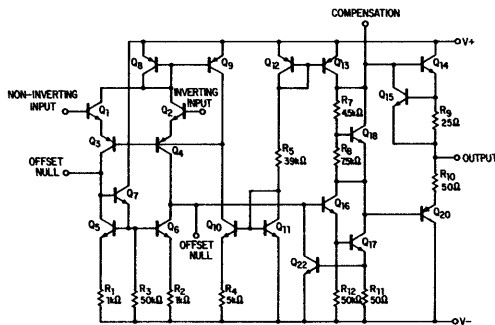

### PIN CONFIGURATIONS

#### A PACKAGE

(Top View)

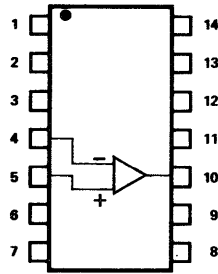

ORDER PART NOS.  
 $\mu$ A748A/ $\mu$ A748CA

1. NC
2. NC
3. Freq. Comp. A/Offset Null
4. Inverting Input
5. Noninverting Input
6.  $V^-$
7. NC
8. NC
9. Offset Null
10. Output
11.  $V^+$
12. Freq. Comp. B
13. NC
14. NC

#### T PACKAGE

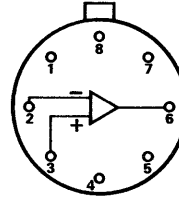

ORDER PART NOS.  
 $\mu$ A748T/ $\mu$ A748CT

1. Freq. Comp. A/ Offset Null.
2. Inverting Input
3. Noninverting Input
4.  $V^-$
5. Offset Null
6. Output
7.  $V^+$
8. Freq. Comp. B

#### V PACKAGE

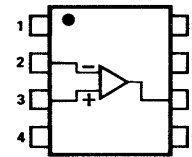

ORDER PART NO.  
 $\mu$ A748CV

1. Freq. Comp. A/ Offset Null.
2. Inverting Input
3. Noninverting Input
4.  $V^-$
5. Offset Null
6. Output
7.  $V^+$
8. Freq. Comp. B

### VOLTAGE OFFSET NULL CIRCUIT

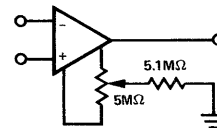

### TRANSIENT RESPONSE TEST CIRCUIT

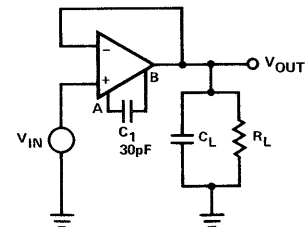

### NOTES:

1. Rating applies for case temperatures to  $+70^{\circ}C$ .
2. For supply voltages less than  $\pm 15V$ , the absolute maximum input voltage is equal to the supply voltage.
3. Short circuit may be to ground or either supply. Rating applies to  $+70^{\circ}C$  ambient temperature.

**SIGNETICS ■  $\mu$ A748/748C – HIGH PERFORMANCE OPERATIONAL AMPLIFIER**

**ELECTRICAL CHARACTERISTICS: ( $V_S = \pm 15V$ ,  $T_A = 25^\circ C$  unless otherwise specified)**

PARAMETER	CONDITIONS	$\mu$ A748C			$\mu$ A748			UNITS
		MIN	TYP	MAX	MIN	TYP	MAX	
Input Offset Voltage	$R_S \leq 10\text{ k}\Omega$		2.0	6.0		1.0	5.0	mV
Input Offset Current			20	200		20	200	nA
Input Bias Current			80	500		80	500	nA
Input Resistance		0.3	2.0		0.3	2.0		M $\Omega$
Input Capacitance			1.4			1.4		pF
Offset Voltage Adjustment Range			$\pm 15$			$\pm 15$		mV
Input Voltage Range		$\pm 12$	$\pm 13$		$\pm 12$	$\pm 13$		V
Large-Signal Voltage Gain	$R_L \geq 2\text{ k}\Omega$ , $V_{out} = \pm 10V$	50K	200K		50K	200K		
Output Resistance			75			75		$\Omega$
Output Short-Circuit Current			25			25		mA
Supply Voltage Rejection Ratio	$R_S \leq 10\text{ k}\Omega$		30	150		30	150	$\mu$ V/V
Common Mode Rejection Ratio	$R_S \leq 10\text{ k}\Omega$	70	90		70	90		dB
Supply Current			1.7	2.8		1.7	2.8	mA
Power Consumption			50	85		50	85	mW
Transient Response (unity gain)	$V_{in} = 20\text{mV}$ , $R_L = 2\text{ k}\Omega$ , $C_L \leq 100\text{ pF}$							
Risetime	$C_1 = 30\text{ pF}$		0.3			0.3		$\mu$ s
Overshoot			5.0			5.0		%
Slew Rate	$R_L \geq 2\text{ k}\Omega$ $C_1 = 30\text{ pF}$		0.5			0.5		V/ $\mu$ s

**The Following Specifications Apply Over the Operating Temperature Ranges**

Input Offset Voltage	$R_S \leq 10\text{ k}\Omega$			7.5			6.0	mV
Input Offset Current	$T_A$ max		9.0	300		7.0	200	nA
	$T_A$ min		35	300		85	500	nA
Input Bias Current	$T_A$ max		0.04	0.8		0.03	0.5	$\mu$ A
	$T_A$ min		0.13	0.8		0.3	1.5	$\mu$ A
Input Voltage Range		$\pm 12$	$\pm 13$		$\pm 12$	$\pm 13$		V
Common Mode Rejection Ratio	$R_S \leq 10\text{ k}\Omega$	70	90		70	90		dB
Supply Voltage Rejection Ratio	$R_S \leq 10\text{ k}\Omega$		30	150		30	150	$\mu$ V/V
Large-Signal Voltage Gain	$R_L \geq 2\text{ k}\Omega$ , $V_{out} = \pm 10V$	25			25			V/mV
Output Voltage Swing	$R_L \geq 10\text{ k}\Omega$	$\pm 12$	$\pm 14$		$\pm 12$	$\pm 14$		V
	$R_L \geq 2\text{ k}\Omega$	$\pm 10$	$\pm 13$		$\pm 10$	$\pm 13$		V
Supply Current	$T_A$ max		1.6	3.3		1.5	2.5	mA
	$T_A$ min		1.8	3.3		2.0	3.3	mA
Power Consumption	$T_A$ max		48	100		45	75	mW
	$T_A$ min		54	100		60	100	mW

**TYPICAL CHARACTERISTIC CURVES**

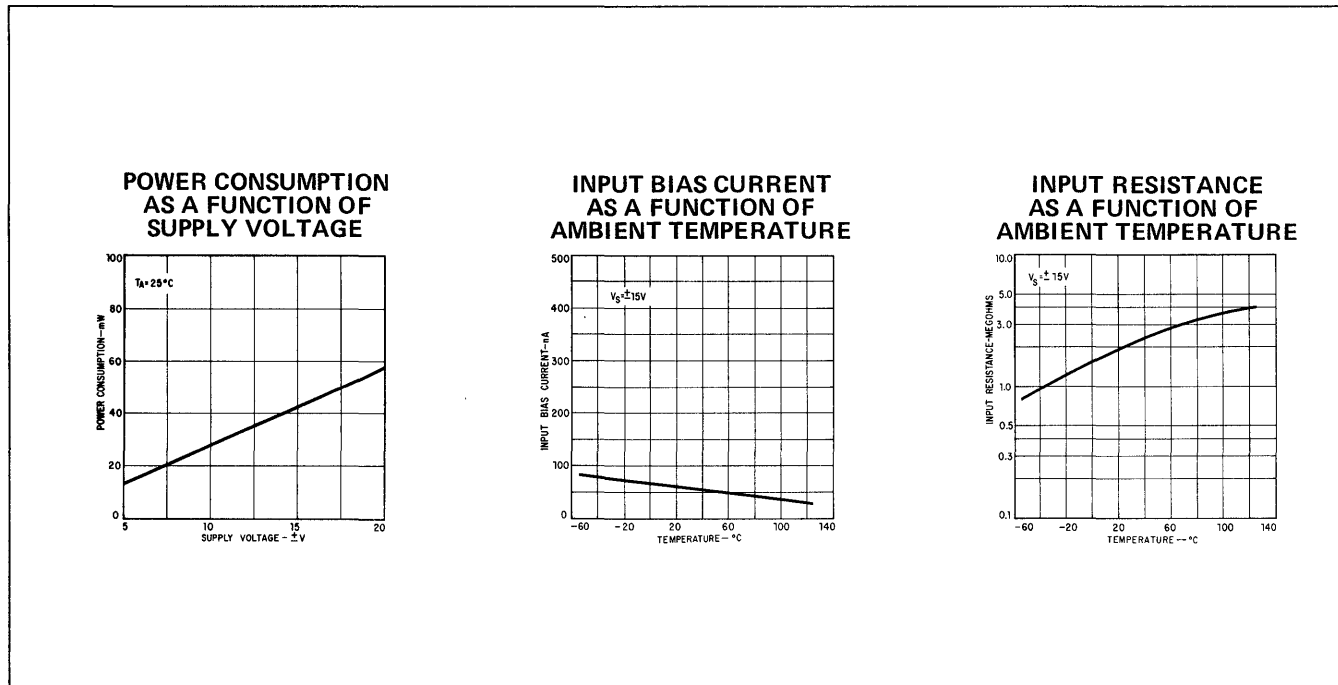

TYPICAL CHARACTERISTIC CURVES (Cont'd.)

INPUT OFFSET CURRENT AS A FUNCTION OF SUPPLY VOLTAGE

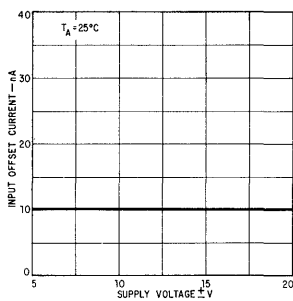

INPUT OFFSET CURRENT AS A FUNCTION OF AMBIENT TEMPERATURE

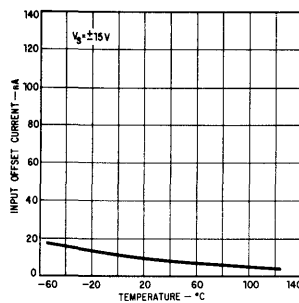

POWER CONSUMPTION AS A FUNCTION OF AMBIENT TEMPERATURE

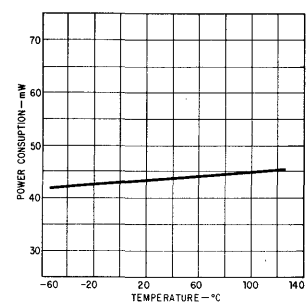

OUTPUT VOLTAGE SWING AS A FUNCTION OF LOAD RESISTANCE

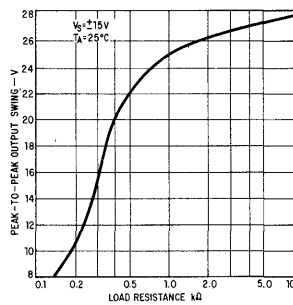

OUTPUT SHORT-CIRCUIT CURRENT AS A FUNCTION OF AMBIENT TEMPERATURE

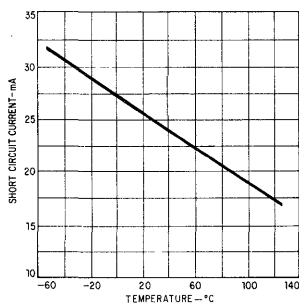

ABSOLUTE MAXIMUM POWER DISSIPATION AS A FUNCTION OF AMBIENT TEMPERATURE

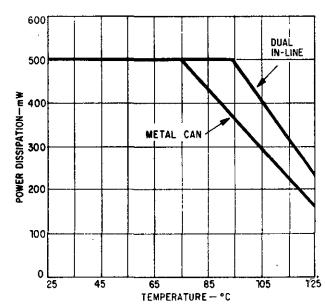

INPUT NOISE CURRENT AS A FUNCTION OF FREQUENCY

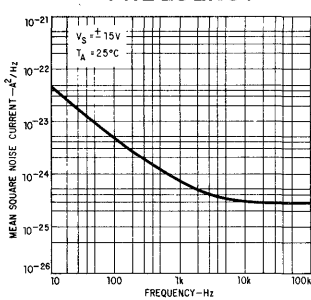

INPUT NOISE VOLTAGE AS A FUNCTION OF FREQUENCY

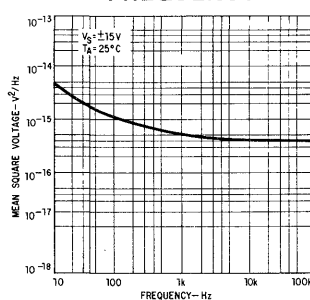

BROADBAND NOISE AS A FUNCTION OF SOURCE RESISTANCE

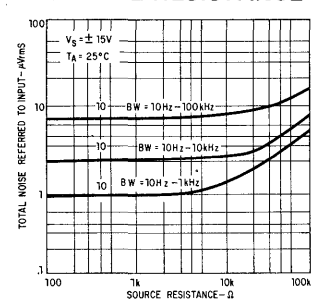

OPEN LOOP VOLTAGE GAIN AS A FUNCTION OF FREQUENCY

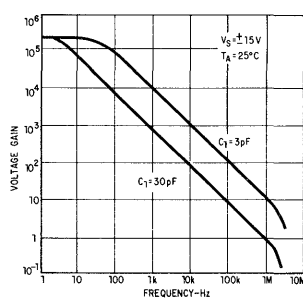

OPEN LOOP PHASE RESPONSE AS A FUNCTION OF FREQUENCY

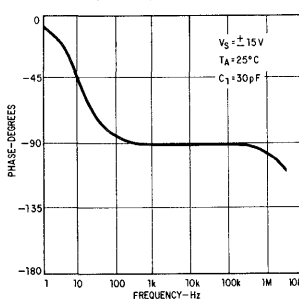

OUTPUT VOLTAGE SWING AS A FUNCTION OF FREQUENCY

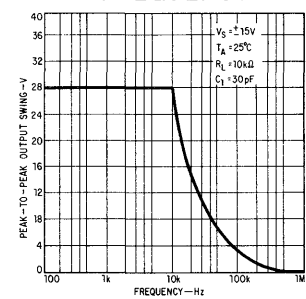

TYPICAL CHARACTERISTIC CURVES (Cont'd.)

INPUT RESISTANCE AND INPUT CAPACITANCE AS A FUNCTION OF FREQUENCY

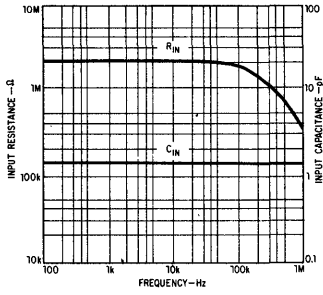

OUTPUT RESISTANCE AS A FUNCTION OF FREQUENCY

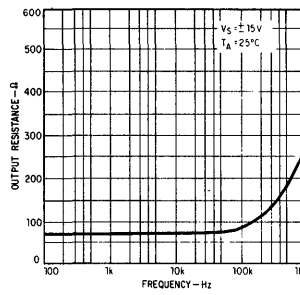

COMMON MODE REJECTION RATIO AS A FUNCTION OF FREQUENCY

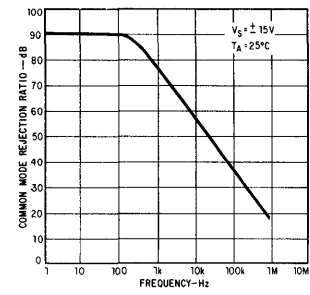

TRANSIENT RESPONSE

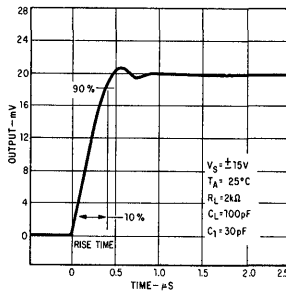

VOLTAGE FOLLOWER LARGE-SIGNAL PULSE RESPONSE

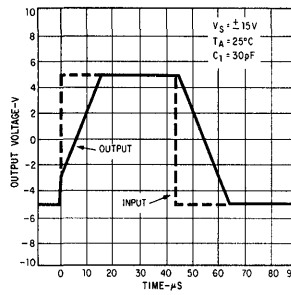

FREQUENCY CHARACTERISTICS AS A FUNCTION OF SUPPLY VOLTAGE

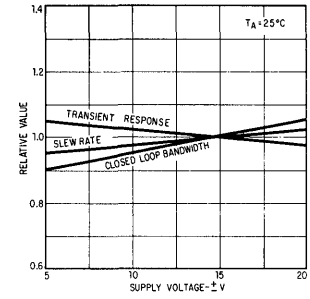

FREQUENCY CHARACTERISTICS AS A FUNCTION OF AMBIENT TEMPERATURE

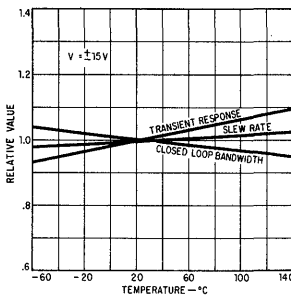

OPEN LOOP VOLTAGE GAIN AS A FUNCTION OF SUPPLY VOLTAGE

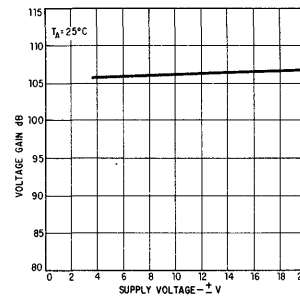

OUTPUT VOLTAGE SWING AS A FUNCTION OF SUPPLY VOLTAGE

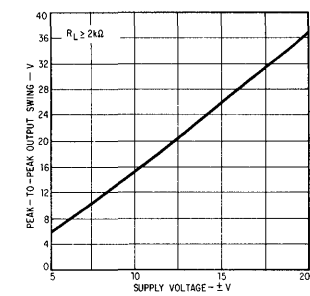

# SECTION 4 voltage regulators



## LINEAR INTEGRATED CIRCUITS

### DESCRIPTION

The 550 is a precision monolithic voltage regulator capable of positive or negative supply operation as series, shunt, switching or floating regulator. Guaranteed line regulation is provided for input voltages ranging from 8.5 volts to as high as 50 volts. The output voltage can be continuously adjusted from 2 volts to 40 volts. Foldback current limiting can be accomplished through the use of one external resistor. Internal circuitry permits on and off strobing with DTL and TTL logic inputs and latched shut-down with a pulsed input.

### FEATURES:

- LINE REGULATION GUARANTEED OVER INPUT VOLTAGE RANGE OF 8.5 VOLTS TO AS HIGH AS 50 VOLTS.
- OUTPUT VOLTAGE CONTINUOUSLY ADJUSTABLE FROM 2 VOLTS TO 40 VOLTS
- LOAD REGULATION 0.1% OF  $V_{out}$
- ADJUSTABLE LIMITING OF SHORT CIRCUIT CURRENT
- FOLDBACK CURRENT LIMITING WITH ONE EXTERNAL RESISTOR
- REMOTE AND LATCHING SHUTDOWN
- OUTPUT CURRENT UP TO 150mA WITHOUT EXTERNAL POWER TRANSISTORS

### BASIC CIRCUIT SCHEMATIC

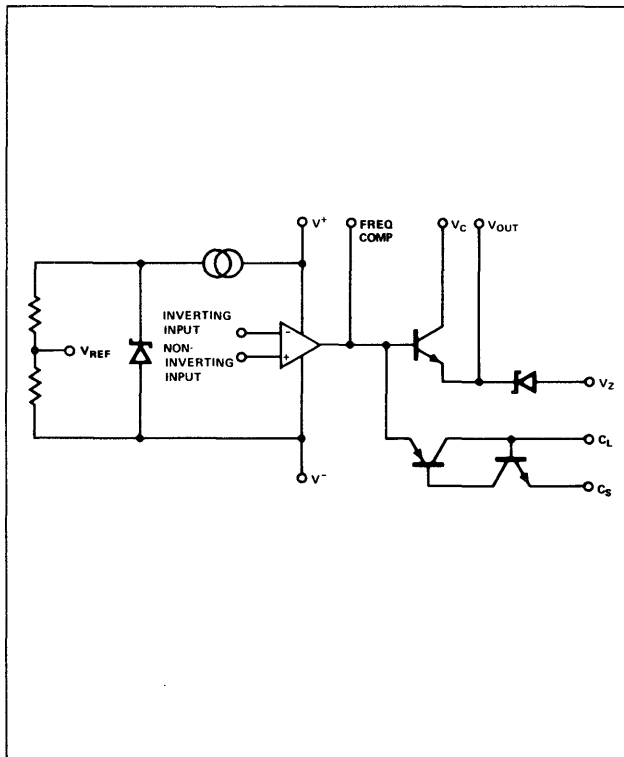

### PIN CONFIGURATIONS

#### A PACKAGE

(Top View)

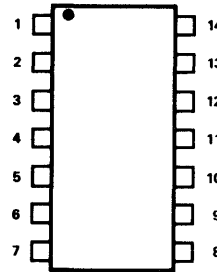

1. NC
2. Current Limit
3. Current Sense
4. Inverting Input
5. Noninverting Input
6.  $V_{REF}$
7.  $V^-$
8. NC
9.  $V_Z$
10.  $V_{out}$
11.  $V_C$
12.  $V^+$
13. Frequency Compensation
14. NC

ORDER PART NO. NE550A

#### L PACKAGE

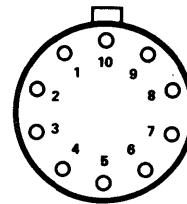

1. Current Sense
2. Inverting Input
3. Noninverting Input
4.  $V_{REF}$
5.  $V^-$
6.  $V_{out}$
7.  $V_C$
8.  $V^+$
9. Frequency Compensation
10. Current Limit

ORDER PART NOS. NE550L/SE550L

### ABSOLUTE MAXIMUM RATINGS:

	SE550	NE550
Voltage from $V^+$ to $V^-$	50V	40V
Input-Output Voltage Differential	45V	37V
Maximum Output Current	150mA	150mA
Current from $V_Z$	15mA	15mA
Internal Power Dissipation (Note 1)	800mW	800mW
Operating Temperature Range	-55°C to +125°C	-0°C to 70°C
Storage Temperature Range	-65°C to +150°C	-65°C to +150°C
Lead Temperature	300°C	300°C

### NOTE:

1. Rating applies for case temperatures to 125°C; derate linearly at 6.5mW/°C for ambient temperatures above +75°C.



**SIGNETICS ■ 550 – PRECISION VOLTAGE REGULATOR**

**ELECTRICAL CHARACTERISTICS** ( $T_A = 25^\circ\text{C}$  unless otherwise specified) (Notes 1 and 2)

PARAMETER	MIN	TYP	MAX	UNITS	TEST CONDITIONS
<b>NE550</b>					
Line Regulation		.08	0.3	% $V_{out}$	$V_{in} = 8.5$ to $40\text{V}$ $0^\circ\text{C} \leq T_A \leq 70^\circ\text{C}$ , $V_{in} = 12$ to $40\text{V}$ $I_L = 1\text{mA}$ to $50\text{mA}$ $0^\circ\text{C} \leq T_A \leq 70^\circ\text{C}$ , $I_L = 1\text{mA}$ to $50\text{mA}$ $f = 50\text{ Hz}$ to $10\text{ kHz}$ , $C_{REF} = 0$ $f = 50\text{ Hz}$ to $10\text{ kHz}$ , $C_{REF} = 5\mu\text{F}$ $0^\circ\text{C} \leq T_A \leq 70^\circ\text{C}$ $RSC = 10\Omega$ , $V_{out} = 0$ $BW = 100\text{ Hz}$ to $10\text{ kHz}$ , $C_{REF} = 0$ $BW = 100\text{ Hz}$ to $10\text{ kHz}$ , $C_{REF} = 5\mu\text{F}$ $I_L = 0$ , $V_{in} = 40\text{V}$
Load Regulation		.03	0.2	% $V_{out}$	
Ripple Rejection		75		dB	
Average Temperature Coefficient of Output Voltage		.002	.015	%/ $^\circ\text{C}$	
Short Circuit Current Limit	50	60	70	mA	
Reference Voltage	1.53	1.63	1.73	V	
Output Noise Voltage		20		$\mu\text{V rms}$	
		2.5		$\mu\text{V rms}$	
Long Term Stability		0.1		%/1000 hrs.	
Standby Current Drain		1.6	3.0	mA	
Input Voltage Range	8.5		40	V	
Output Voltage Range	2.0		37	V	
Input-Output Voltage Differential	3.0		38	V	
<b>SE550</b>					
Line Regulation		0.05	0.1	% $V_{out}$	$V_{in} = 12$ to $40\text{V}$ $V_{in} = 8.5$ to $50\text{V}$ $-55^\circ\text{C} \leq T_A \leq +125^\circ\text{C}$ , $V_{in} = 12$ to $40\text{V}$ $I_L = 1\text{mA}$ to $50\text{mA}$ $-55^\circ\text{C} \leq T_A \leq +125^\circ\text{C}$ , $I_L = 1\text{mA}$ to $50\text{mA}$ $F = 50\text{ Hz}$ to $10\text{ kHz}$ , $C_{REF} = 0$ $F = 50\text{ Hz}$ to $10\text{ kHz}$ , $C_{REF} = 5\mu\text{F}$ $-55^\circ\text{C} \leq T_A \leq +125^\circ\text{C}$ $RSC = 10\Omega$ , $V_{out} = 0$ $BW = 100\text{ Hz}$ to $10\text{ kHz}$ , $C_{REF} = 0$ $BW = 100\text{ Hz}$ to $10\text{ kHz}$ , $C_{REF} = 5\mu\text{F}$ $I_L = 0$ , $V_{in} = 50\text{V}$
Load Regulation		0.3	.10	% $V_{out}$	
Ripple Rejection		75		dB	
Average Temperature Coefficient of Output Voltage		.002	.012	%/ $^\circ\text{C}$	
Short Circuit Limit	50	60	70	mA	
Reference Voltage	1.58	1.63	1.68	V	
Output Noise Voltage		20		$\mu\text{V rms}$	
		2.5		$\mu\text{V rms}$	
Long Term Stability		0.1		%/1000 hrs.	
Standby Current Drain		1.3	2.0	mA	
Input Voltage Range	8.5		50	V	
Output Voltage Range	2.0		40	V	
Input-Output Voltage Differential	3.0		45	V	

**NOTES**

1. Unless otherwise specified,  $T_A = 25^\circ\text{C}$ ,  $V_{in} = V^+ = V_C = 12\text{V}$ ,  $V^- = 0\text{V}$ ,  $V_{out} = 5\text{V}$ ,  $I_L = 1\text{mA}$ ,  $R_{SC} = 0$ ,  $C_1 = 100\text{pF}$ , and divider impedance as seen by error amplifier  $\approx 2\text{k}\Omega$  when connected as shown in Figure 1.
2. The load and line regulation specifications are for constant junction temperature. Temperature drift effects must be taken into account separately when the unit is operating under conditions of high or varying dissipation.

**TYPICAL CHARACTERISTIC CURVES**

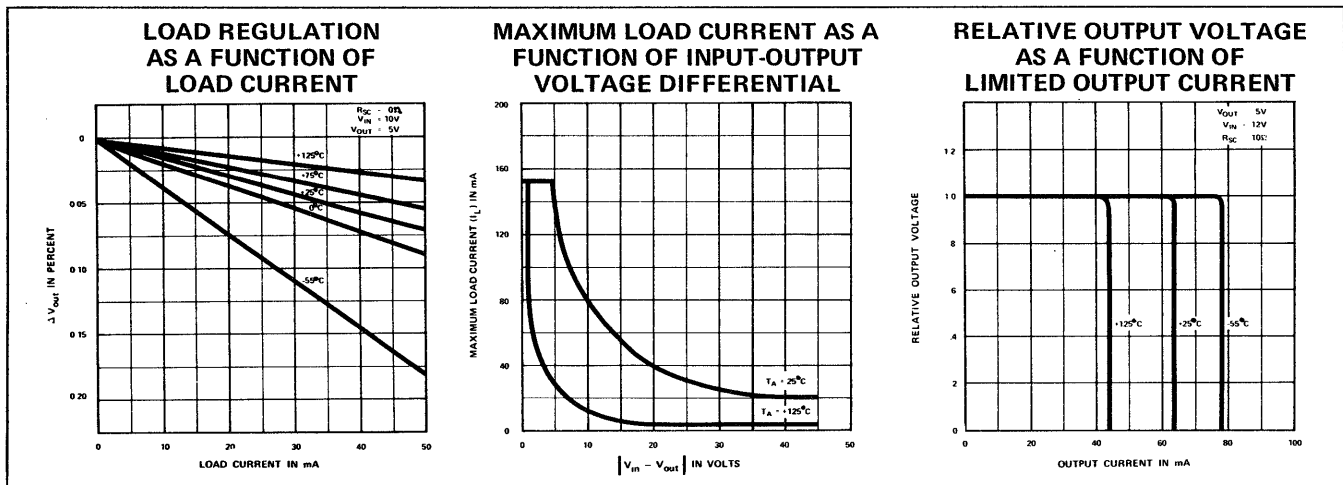

TYPICAL CHARACTERISTIC CURVES (Cont'd.)

**RIPPLE REJECTION AS A FUNCTION OF INPUT-OUTPUT VOLTAGE DIFFERENTIAL**

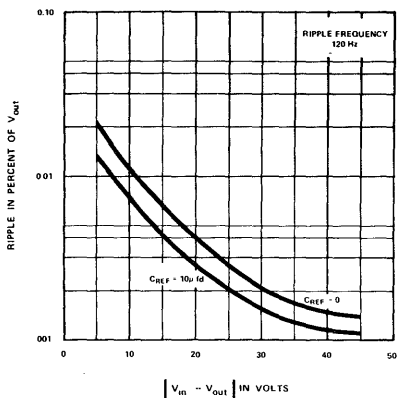

**SENSE VOLTAGE AND SHORT CIRCUIT CURRENT LIMIT AS A FUNCTION OF TEMPERATURE**

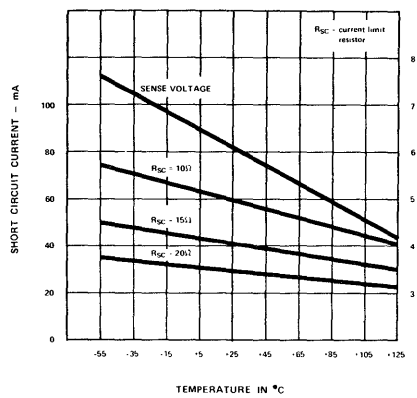

**SHORT CIRCUIT FOLDBACK CURRENT AS A FUNCTION OF TEMPERATURE**

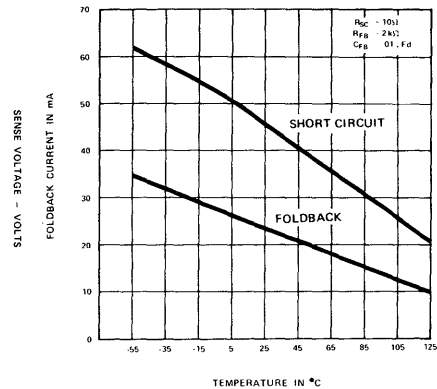

**REMOTE CONTROL CHARACTERISTICS AS A FUNCTION OF TEMPERATURE**

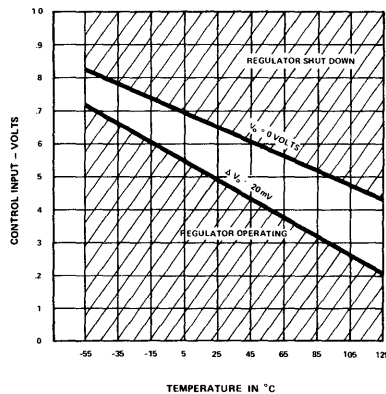

**OUTPUT IMPEDANCE AS A FUNCTION OF FREQUENCY**

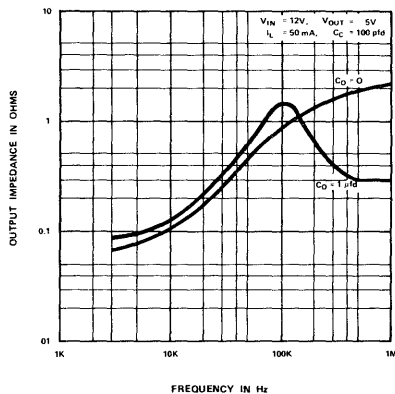

**LINE TRANSIENT RESPONSE**

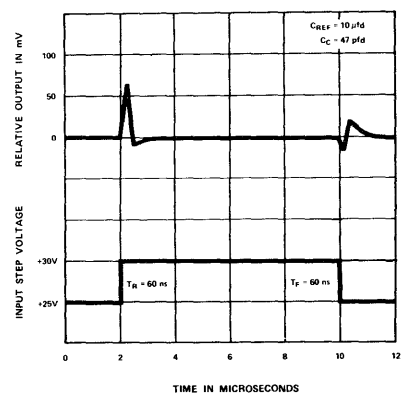

**LOAD TRANSIENT RESPONSE**

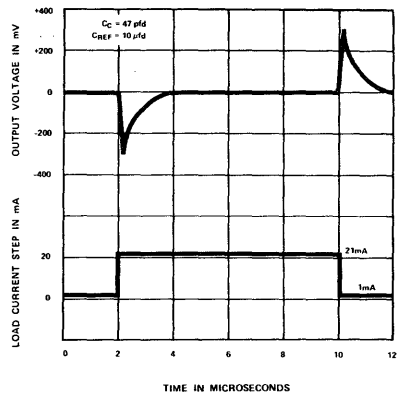

**STANDBY CURRENT AS A FUNCTION OF INPUT VOLTAGE**

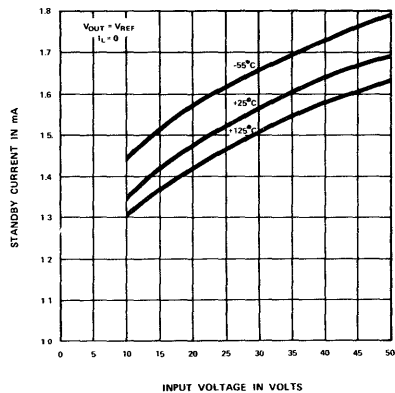

**FOLDBACK CURRENT LIMITED OUTPUT VOLTAGE AS A FUNCTION OF OUTPUT CURRENT**

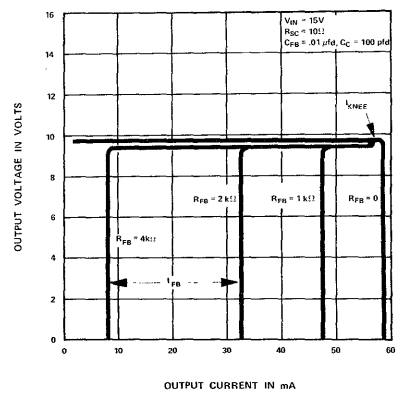

TYPICAL APPLICATIONS

**BASIC POSITIVE VOLTAGE REGULATOR**

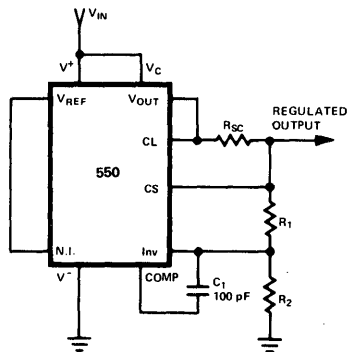

$$V_{out} = V_{REF} \frac{R_1 + R_2}{R_2}$$

$$\frac{R_1 R_2}{R_1 + R_2} = 2k\Omega \text{ for minimum temperature drift}$$

FIGURE 1

**NEGATIVE VOLTAGE REGULATOR**

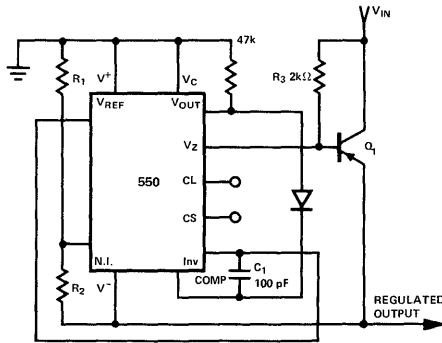

$$V_{out} = -V_{REF} \times \frac{R_1 + R_2}{R_2}$$

$$\frac{R_1 R_2}{R_1 + R_2} = 2k\Omega \text{ for minimum temperature drift}$$

NOTE 1

FIGURE 2

**POSITIVE VOLTAGE REGULATOR (External PNP Pass Transistor)**

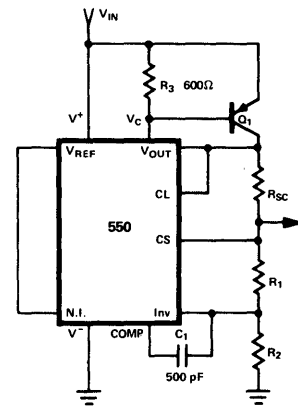

FIGURE 3

**POSITIVE VOLTAGE REGULATOR (External NPN Pass Transistor)**

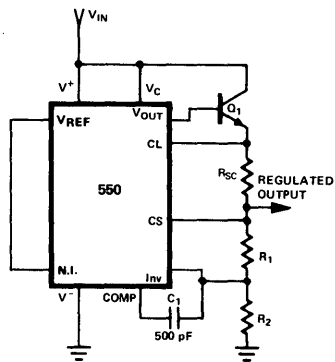
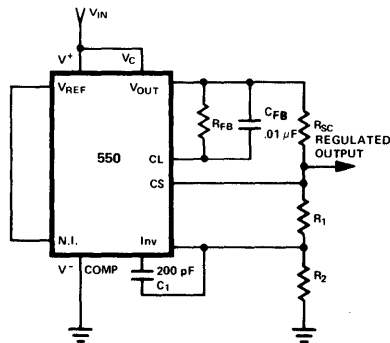

FIGURE 4.

**FOLDBACK CURRENT LIMITED OUTPUT VOLTAGE AS A FUNCTION OF OUTPUT CURRENT**



$$I_{SC} = \frac{V_{SENSE}}{R_{SC}}$$

$$R_A = \frac{I_{FL} R_{SC} - V_{SENSE}}{I_{BLEED}}$$

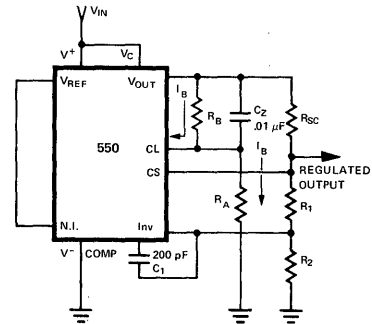

$$R_B = \frac{V_{OUT} + V_{SENSE}}{I_B + I_{BIAS}}$$

FIGURE 5.

**REMOTE SHUTDOWN REGULATOR WITH CURRENT LIMITING**

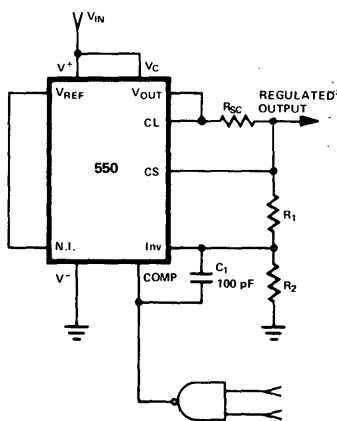

1/4 8T80, 1/6 8T90, 1/10 8T01B, etc.

FIGURE 6

**REMOTE LATCHING SHUTDOWN REGULATOR**

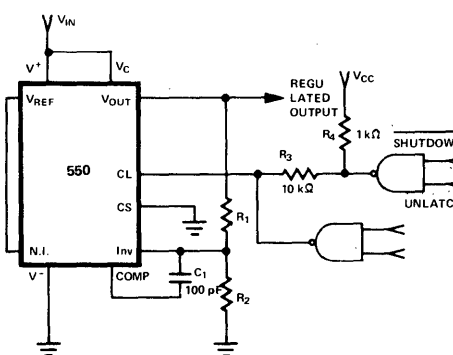

8415, 8417, 2/3 8471, 1/3 8891, 8T90, 1/2 8481, 8881, 8T90

NOTE 2

FIGURE 7

**POSITIVE SWITCHING REGULATOR**

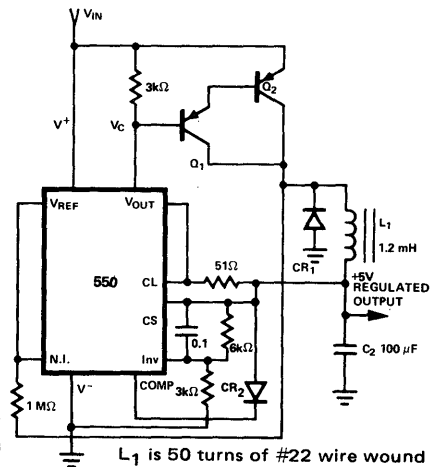

L<sub>1</sub> is 50 turns of #22 wire wound on Ferroxcube. 42/29-377 A400

FIGURE 8

TYPICAL APPLICATIONS (Cont'd.)

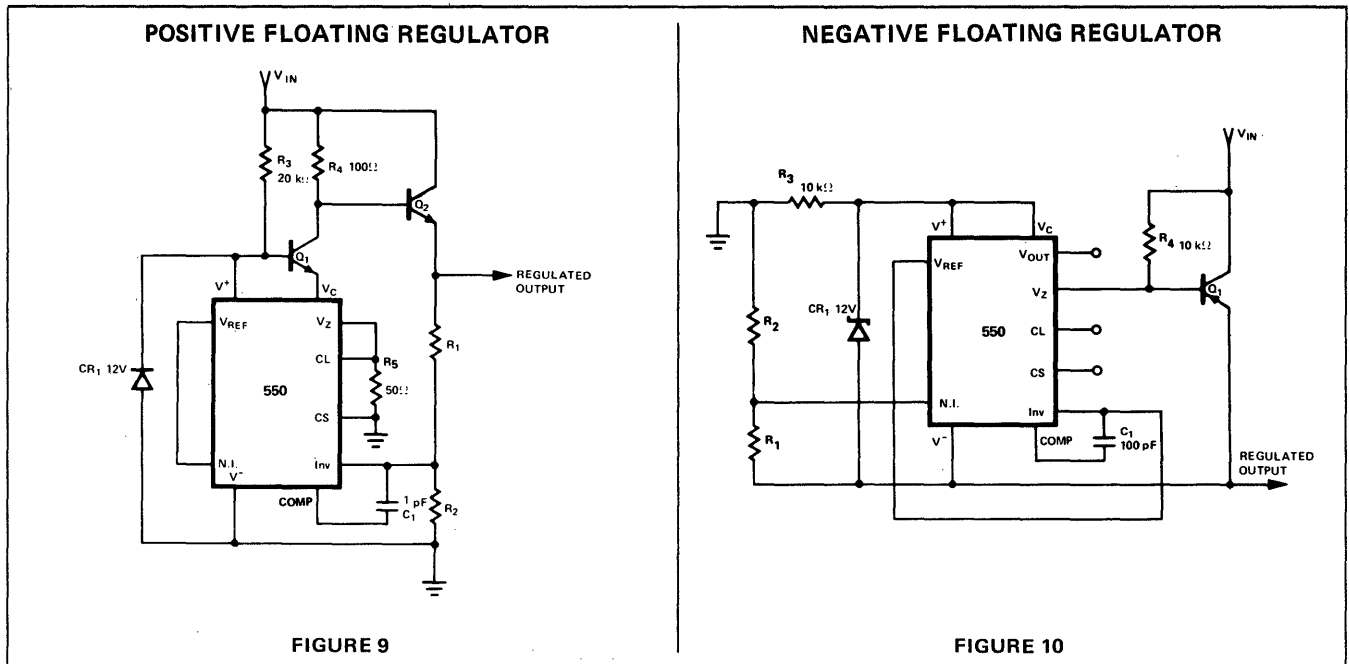

FIGURE 9

FIGURE 10

NOTES:

1. To utilize the SE550L in applications which require  $V_z$ , an external 6.2 volt zener diode should be connected in series with  $V_{OUT}$ .
2. The "Shut-down" gate need only be pulsed to latch the regulator output to zero.  $R_4$  may be omitted for active pull-up devices. The "Unlatch" gate must have an open collector.

EQUIVALENT CIRCUIT

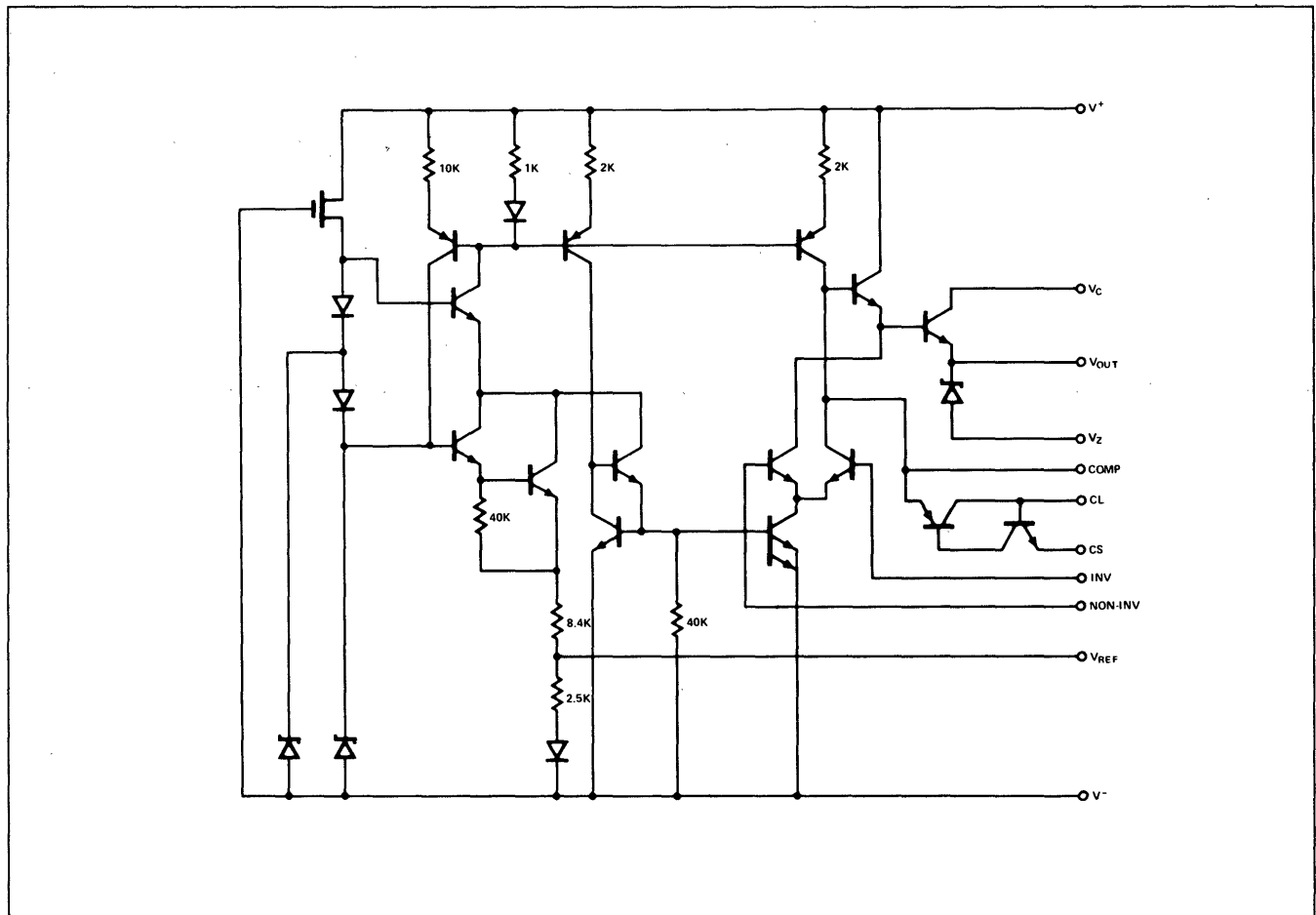



### LINEAR INTEGRATED CIRCUITS

#### DESCRIPTION

The LM109 and LM309 are complete 5 volt regulators fabricated on a single silicon chip. These regulators are designed for local "on card" regulation to eliminate many of the noise and ground loop problems associated with single-point regulation. They employ internal current limiting, thermal shutdown, and safe-area compensation which makes the circuitry essentially blow-out proof. If adequate heat sinking is provided, the devices can deliver output currents in excess of 200mA from the TO-5 package, and 1A from the TO-3 package. In addition to their use as fixed 5 volt regulators, these devices may be used with external components to obtain adjustable output levels. They may also be used as the power pass element in precision regulators.

#### FEATURES

- OUTPUT CURRENTS IN EXCESS OF 1 amp
- INTERNAL THERMAL OVERLOAD PROTECTION
- INTERNAL CURRENT LIMITING
- NO EXTERNAL COMPONENTS REQUIRED

#### ABSOLUTE MAXIMUM RATINGS

Input Voltage	35V
Power Dissipation	Internally Limited
Operating Junction Temperature Range	
LM109	-55°C to 150°C
LM309	0°C to 125°C
Storage Temperature Range	-65°C to 150°C
Lead Temperature (Soldering, 10 sec)	300°C

#### PIN CONFIGURATIONS

##### H PACKAGE (Top View)

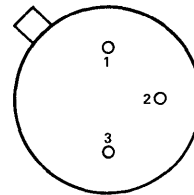

1. Input
2. Output
3. Ground

ORDER PART NOS. LM109H/LM309H

##### K PACKAGE

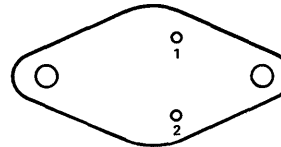

1. Input
2. Output

Case is connected to ground.

ORDER PART NOS. LM109K/LM309K

#### EQUIVALENT CIRCUIT

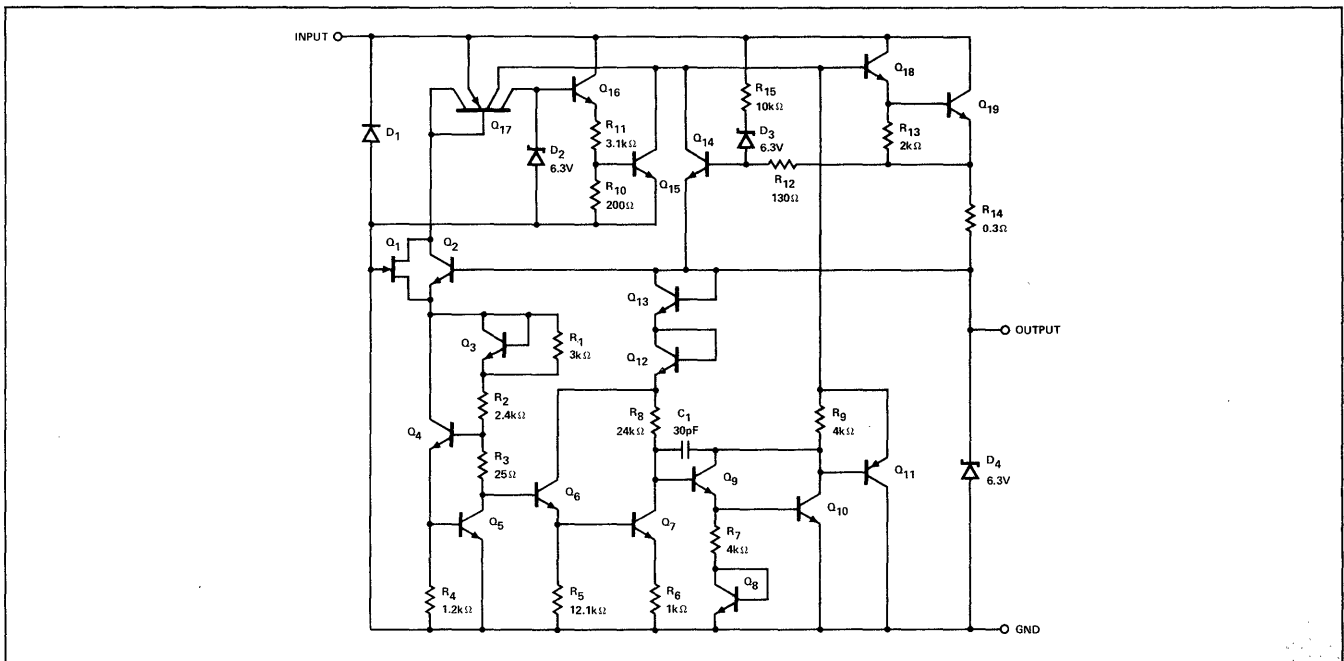

ELECTRICAL CHARACTERISTICS (Note 1)

PARAMETER	CONDITIONS	LM109			LM309			UNITS
		MIN	TYP	MAX	MIN	TYP	MAX	
Output Voltage	$T_j = 25^\circ\text{C}$	4.7	5.05	5.3	4.8	5.05	5.2	V
Line Regulation	$T_j = 25^\circ\text{C}$ $7\text{V} \leq V_{IN} \leq 25\text{V}$		4	50		4	50	mV
Load Regulation	$T_j = 25^\circ\text{C}$							
TO-5	$5\text{mA} \leq I_{OUT} \leq 0.5\text{A}$		20	50		20	50	mV
TO-3	$5\text{mA} \leq I_{OUT} \leq 1.5\text{A}$		50	100		50	100	mV
Output Voltage	$7\text{V} \leq V_{IN} \leq 25\text{V}$ $5\text{mA} \leq I_{OUT} \leq I_{max}$ $P < P_{max}$	4.6		5.4	4.75		5.25	V
Quiescent Current	$7\text{V} \leq V_{IN} \leq 25\text{V}$		5.2	10		5.2	10	mA
Quiescent Current Change	$7\text{V} \leq V_{IN} \leq 25\text{V}$ $5\text{mA} \leq I_{OUT} \leq I_{max}$			0.5			0.5	mA
Output Noise Voltage	$T_A = 25^\circ\text{C}$ $10\text{Hz} \leq f \leq 100\text{kHz}$		40			40		$\mu\text{V}$
Long Term Stability				10			20	mV
Thermal Resistance								
Junction to Case (Note 2)								
TO-5			15			15		$^\circ\text{C/W}$
TO-3			3			3		$^\circ\text{C/W}$

NOTES:

1. Unless otherwise specified, these specifications apply for  $-55^\circ\text{C} \leq T_j \leq 150^\circ\text{C}$  for the 5109 or  $0^\circ\text{C} \leq T_j \leq 125^\circ\text{C}$  for the 5309,  $V_{IN} = 10\text{V}$  and  $I_{OUT} = 0.1\text{A}$  for the TO-5 package or  $I_{OUT} = 0.5\text{A}$  for the TO-3 package. For the TO-5 package,  $I_{max} = 0.2\text{A}$  and  $P_{max} = 2.0\text{W}$ . For the TO-3 package,  $I_{max} = 1.0\text{A}$  and  $P_{max} = 20\text{W}$ .

2. Without a heat sink, the thermal resistance of the TO-5 package is about  $150^\circ\text{C/W}$ , while that of the TO-3 package is approximately  $35^\circ\text{C/W}$ . With a heat sink, the effective thermal resistance can only approach the values specified, depending on the efficiency of the sink.

TYPICAL APPLICATIONS

FIXED 5V REGULATOR

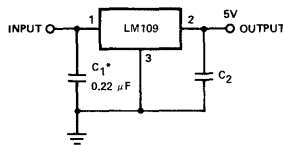

NOTES: \*Required if regulator is located an appreciable distance from power supply filter.

†Although no output capacitor is needed for stability, it does improve transient response.

PRECISION VOLTAGE REGULATOR

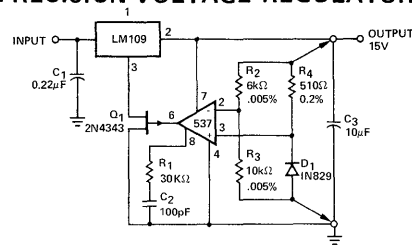

NOTES: \*Regulation better than 0.01% load, line and temperature, can be obtained.

†Determines zener current. May be adjusted to minimize thermal drift.

‡Solid tantalum.

ADJUSTABLE OUTPUT REGULATOR

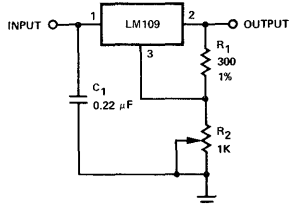

CURRENT REGULATOR

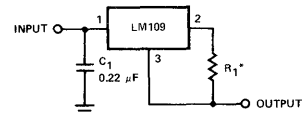

NOTES: \*Determines output current.

TYPICAL CHARACTERISTIC CURVES

MAXIMUM AVERAGE POWER DISSIPATION  
LM109 (TO-3)

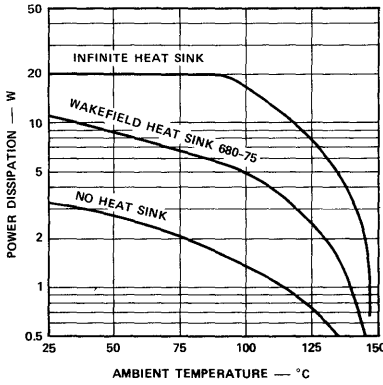

MAXIMUM AVERAGE POWER DISSIPATION  
LM309 (TO-3)

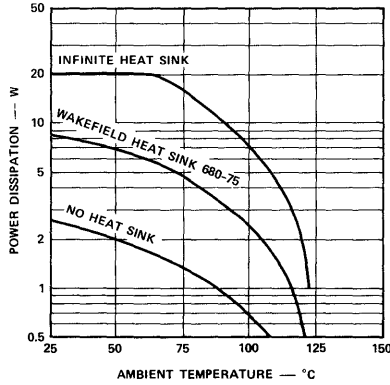

MAXIMUM AVERAGE POWER DISSIPATION  
LM109 (TO-5)

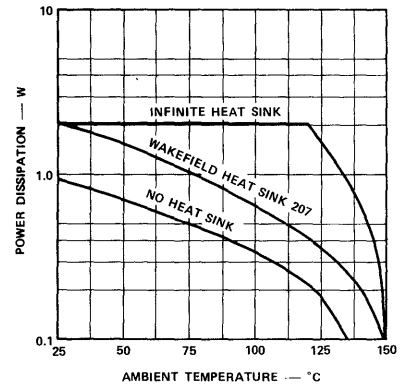

MAXIMUM AVERAGE POWER DISSIPATION  
LM309 (TO-5)

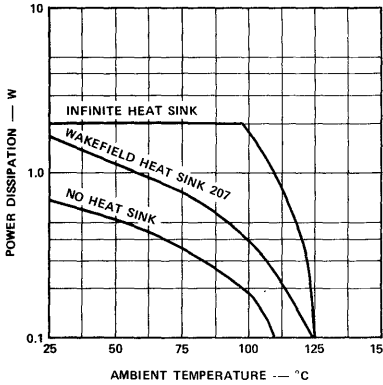

OUTPUT IMPEDANCE

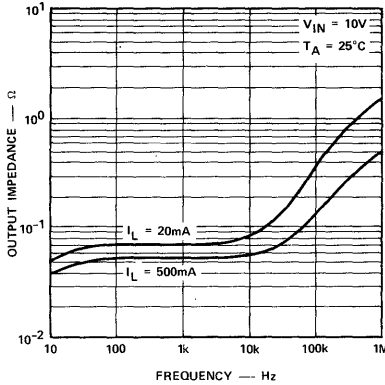

PEAK OUTPUT CURRENT  
K PACKAGE (TO-3)

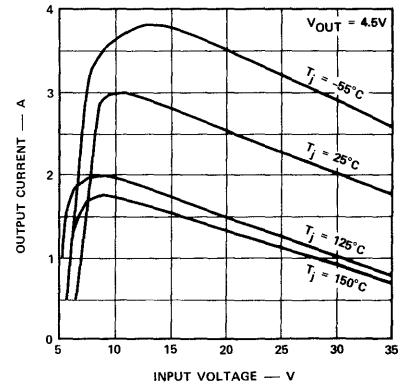

PEAK OUTPUT CURRENT  
H PACKAGE (TO-5)

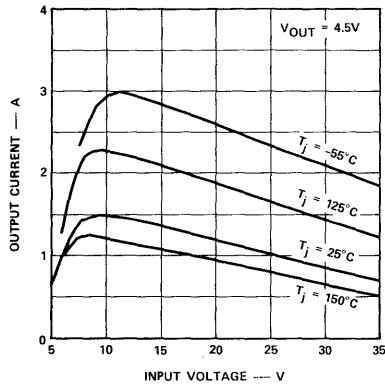

RIPPLE REJECTION

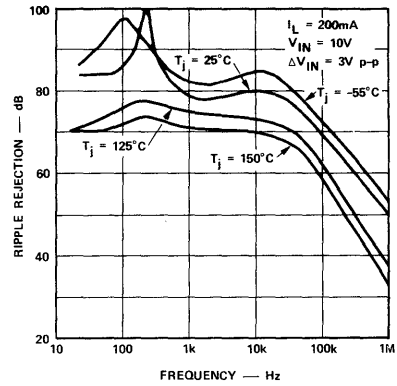



TYPICAL CHARACTERISTIC CURVES (Cont'd.)

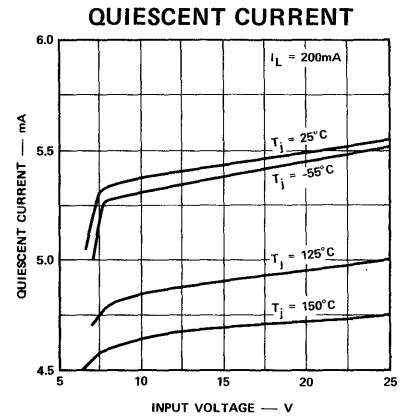
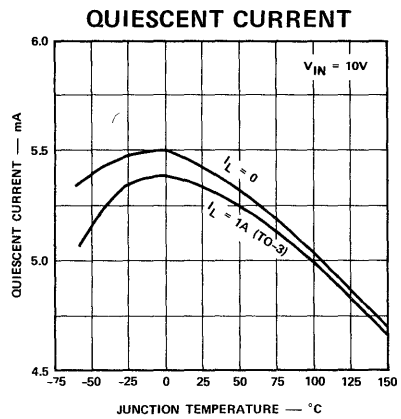
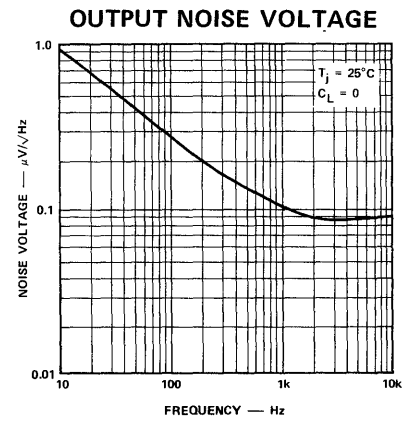
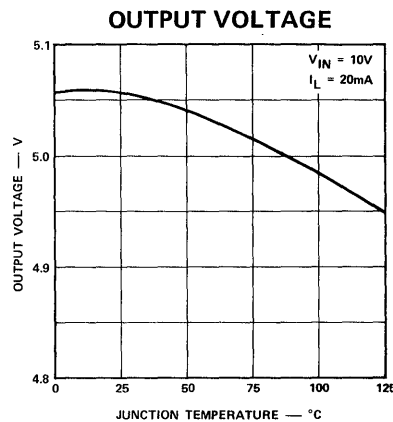
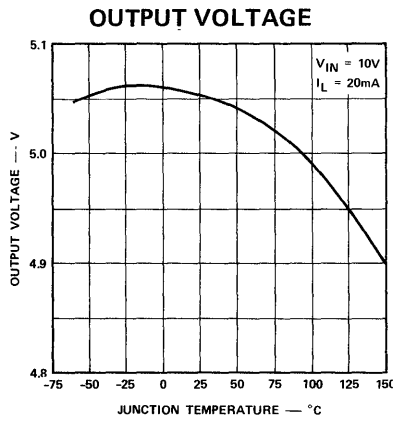
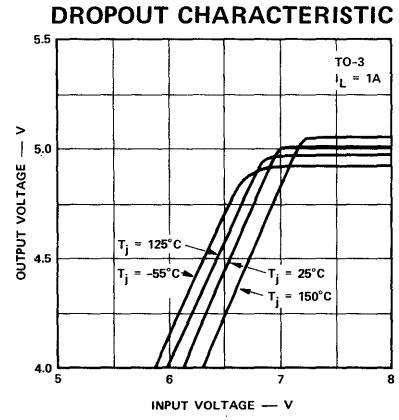
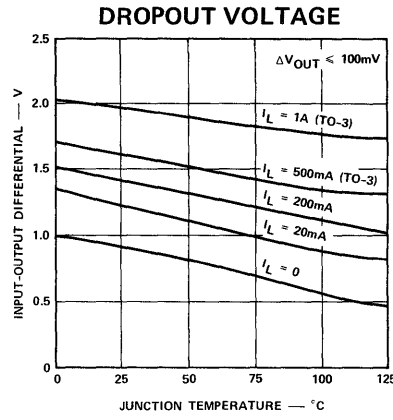
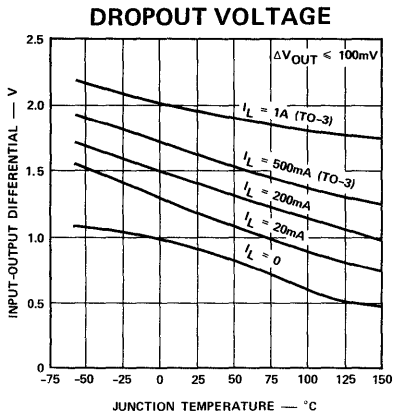



**SIGNETICS ■  $\mu$ A723/723C – PRECISION VOLTAGE REGULATOR**

**ELECTRICAL CHARACTERISTICS ( $T_A = 25^\circ\text{C}$  unless otherwise specified – Note 1)**

PARAMETER (See definitions)	MIN	TYP	MAX	UNITS	CONDITIONS
<b><math>\mu</math>A723C</b>					
Line Regulation (Note 2)		0.01 0.1	0.1 0.5	% $V_{out}$ % $V_{out}$	$V_{in} = 12\text{V}$ to $V_{in} = 15\text{V}$ $V_{in} = 12\text{V}$ to $V_{in} = 40\text{V}$
Load Regulation (Note 2)		0.03	0.2	% $V_{out}$	$I_L = 1\text{mA}$ to $I_L = 50\text{mA}$
Ripple Rejection		74 86		dB dB	$f = 50\text{ Hz}$ to $10\text{ kHz}$ , $C_{REF} = 0$ $f = 50\text{ Hz}$ to $10\text{ kHz}$ , $C_{REF} = 5\mu\text{F}$
Short Circuit Current Limit		65		mA	$R_{sc} = 10\Omega$ , $V_{out} = 0$
Reference Voltage	6.80	7.15	7.50	V	
Output Noise Voltage		20 2.5		$\mu\text{V rms}$ $\mu\text{V rms}$	$BW = 100\text{ Hz}$ to $10\text{ kHz}$ , $C_{REF} = 0$ $BW = 100\text{ Hz}$ to $10\text{ kHz}$ , $C_{REF} = 5\mu\text{F}$
Long Term Stability			0.1	%/1000 hrs.	
Standby Current Drain		2.3	4.0	mA	$I_L = 0$ , $V_{in} = 30\text{V}$
Input Voltage Range	9.5		40	V	
Output Voltage Range	2.0		37	V	
Input-Output Voltage Differential	3.0		38	V	
The Following Specifications Apply Over the Operating Temperature Ranges					
Line Regulation			0.3	% $V_{out}$	$V_{in} = 12\text{V}$ to $V_{in} = 15\text{V}$
Load Regulation			0.6	% $V_{out}$	$I_L = 1\text{mA}$ to $I_L = 50\text{mA}$
Average Temperature Coefficient of Output Voltage		0.003	0.015	%/ $^\circ\text{C}$	
<b><math>\mu</math>A723</b>					
Line Regulation (Note 2)		0.01 0.02	0.1 0.2	% $V_{out}$ % $V_{out}$	$V_{in} = 12\text{V}$ to $V_{in} = 15\text{V}$ $V_{in} = 12\text{V}$ to $V_{in} = 40\text{V}$
Load Regulation (Note 2)		0.03	0.15	% $V_{out}$	$I_L = 1\text{mA}$ to $I_L = 50\text{mA}$
Ripple Rejection		74 86		dB dB	$f = 50\text{ Hz}$ to $10\text{ kHz}$ , $C_{REF} = 0$ $f = 50\text{ Hz}$ to $10\text{ kHz}$ , $C_{REF} = 5\mu\text{F}$
Short Circuit Current Limit		65		mA	$R_{sc} = 10\Omega$ , $V_{out} = 0$
Reference Voltage	6.95	7.15	7.35	V	
Output Noise Voltage		20 2.5		$\mu\text{V rms}$ $\mu\text{V rms}$	$BW = 100\text{ Hz}$ to $10\text{ kHz}$ , $C_{REF} = 0$ $BW = 100\text{ Hz}$ to $10\text{ kHz}$ , $C_{REF} = 5\mu\text{F}$
Long Term Stability		0.1		%/1000 hrs	
Standby Current Drain		2.3	3.5	mA	$I_L = 0$ , $V_{in} = 30\text{V}$
Input Voltage Range	9.5		40	V	
Output Voltage Range	2.0		37	V	
Input-Output Voltage Differential	3.0		38	V	
The Following Specifications Apply Over the Operating Temperature Ranges					
Line Regulation			0.3	% $V_{out}$	$V_{in} = 12\text{V}$ to $V_{in} = 15\text{V}$
Load Regulation			0.6	% $V_{out}$	$I_L = 1\text{mA}$ to $I_L = 50\text{mA}$
Average Temperature Coefficient of Output Voltage		0.002	0.015	%/ $^\circ\text{C}$	

**NOTES**

1. Unless otherwise specified,  $T_A = 25^\circ\text{C}$ ,  $V_{in} = V^+ = V_c = 12\text{V}$ ,  $V^- = 0\text{V}$ ,  $V_{out} = 5\text{V}$ ,  $I_L = 1\text{mA}$ ,  $R_{sc} = 0$ ,  $C_1 = 100\text{pF}$ ,  $C_{REF} = 0$  and divider impedance as seen by error amplifier  $\leq 10\text{k}\Omega$  when connected as shown in Figure 3.

2. The load and line regulation specifications are for constant junction temperature. Temperature drift effects must be taken into account separately when the unit is operating under conditions of high dissipation.

TYPICAL CHARACTERISTIC CURVES

STANDBY CURRENT DRAIN AS A FUNCTION OF INPUT VOLTAGE

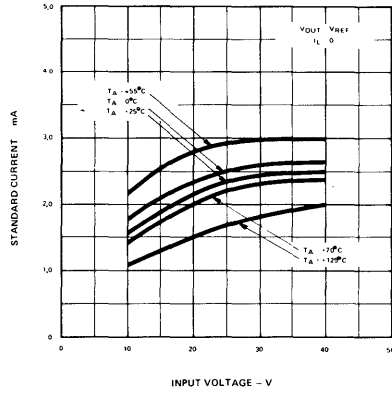

MAXIMUM LOAD CURRENT AS A FUNCTION OF INPUT-OUTPUT VOLTAGE DIFFERENTIAL

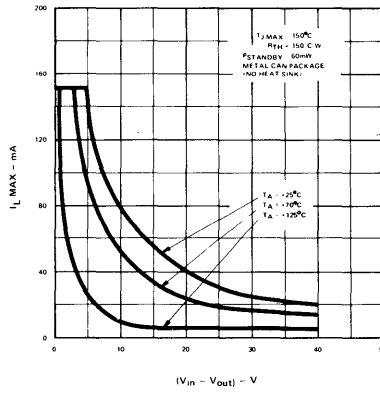

LOAD REGULATION CHARACTERISTICS WITH CURRENT LIMITING

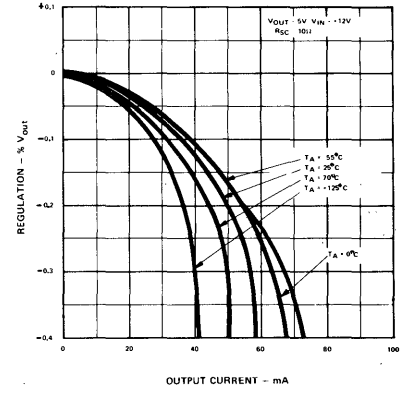

CURRENT LIMITING CHARACTERISTICS AS A FUNCTION OF JUNCTION TEMPERATURE

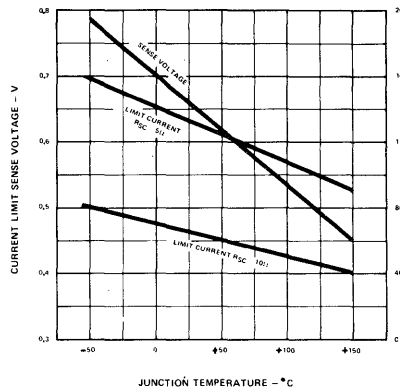

MAXIMUM LOAD CURRENT AS A FUNCTION OF INPUT-OUTPUT VOLTAGE DIFFERENTIAL

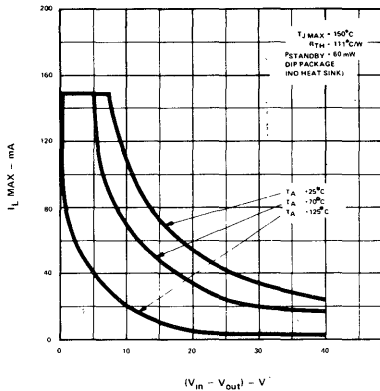

LOAD REGULATION CHARACTERISTICS WITHOUT CURRENT LIMITING

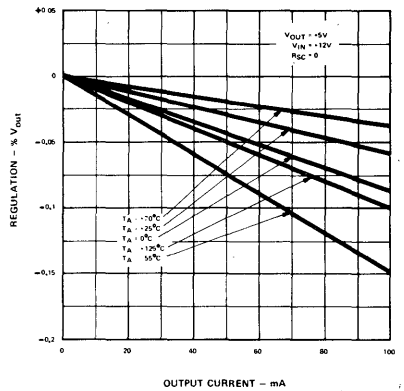

LOAD TRANSIENT RESPONSE

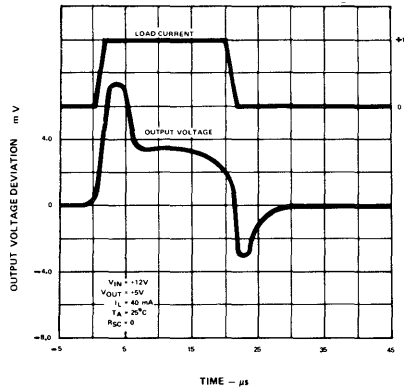

LINE REGULATION AS A FUNCTION OF INPUT-OUTPUT VOLTAGE DIFFERENTIAL

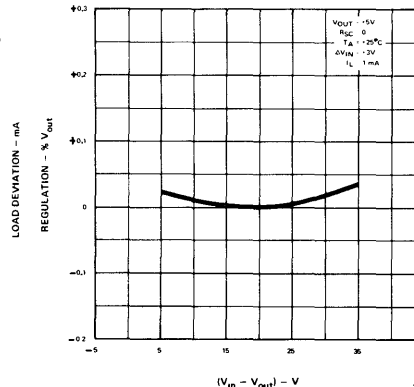

OUTPUT IMPEDANCE AS A FUNCTION OF FREQUENCY

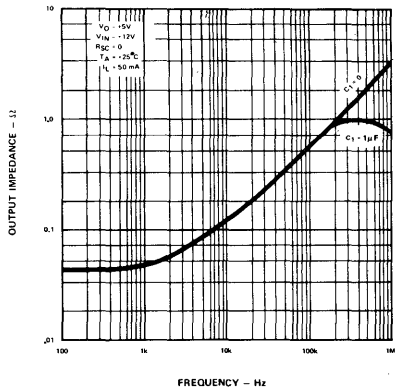

TYPICAL CHARACTERISTIC CURVES (Cont'd.)

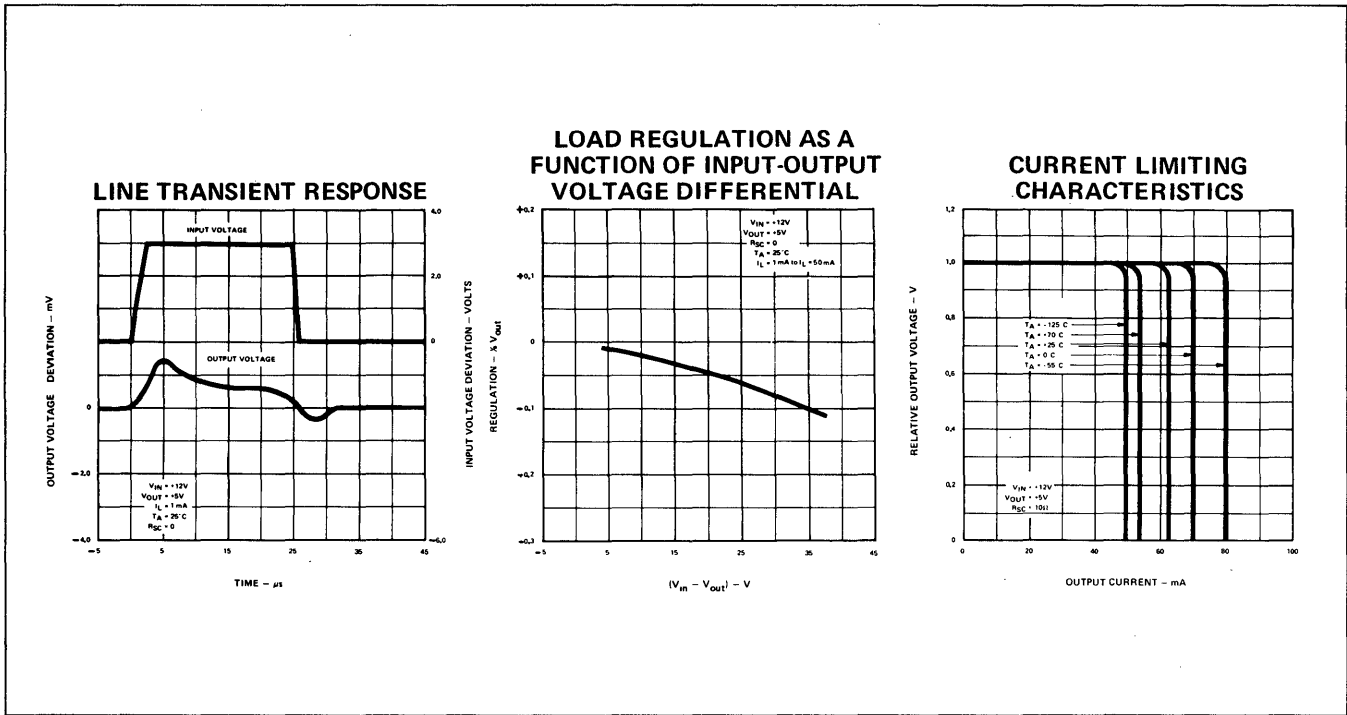

BASIC  $\mu A723$  REGULATOR APPLICATIONS

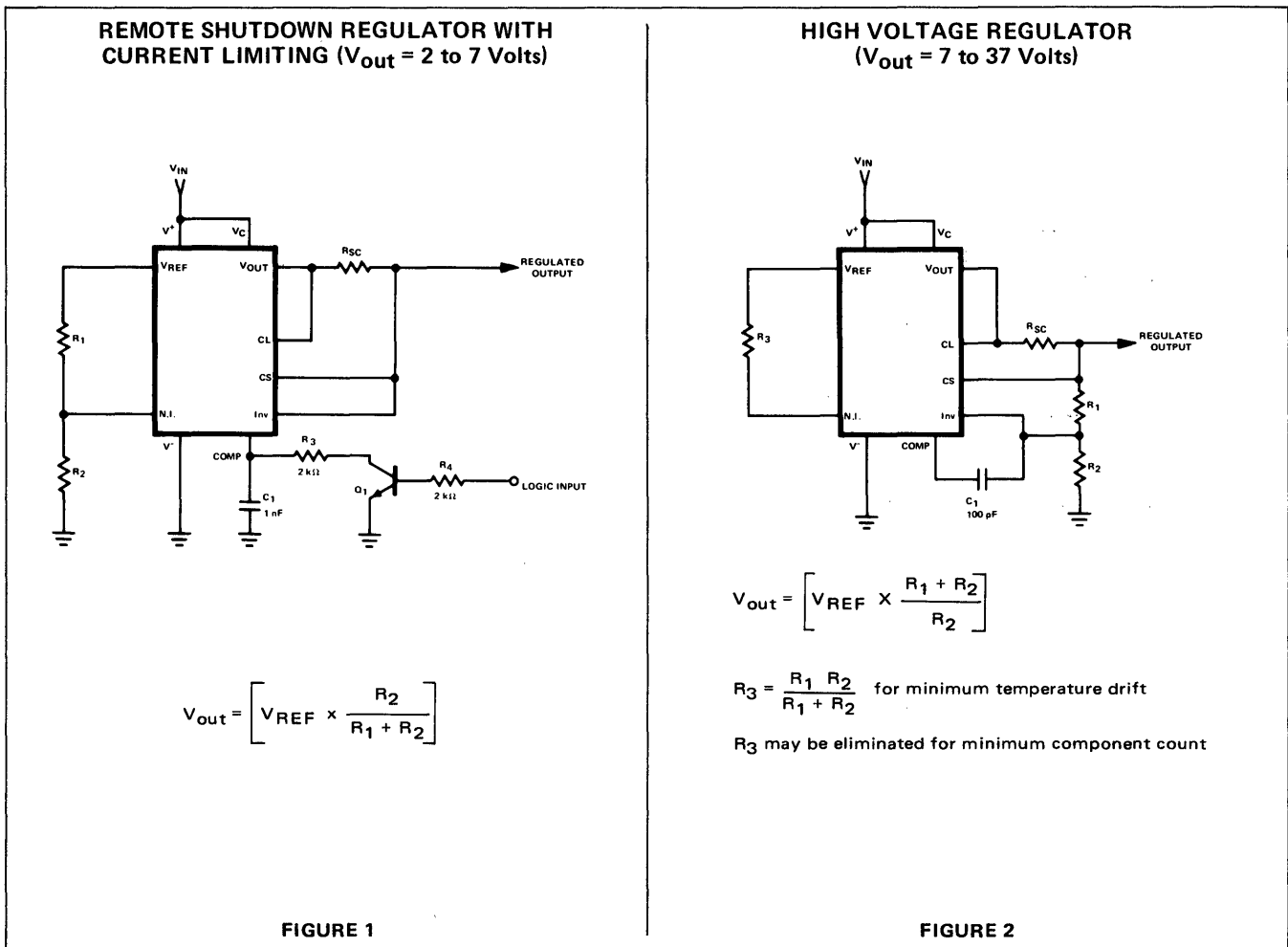

BASIC  $\mu$ A723 REGULATOR APPLICATIONS (Cont'd.)

**LOW VOLTAGE REGULATOR**  
( $V_{out} = 2$  to 7 Volts)

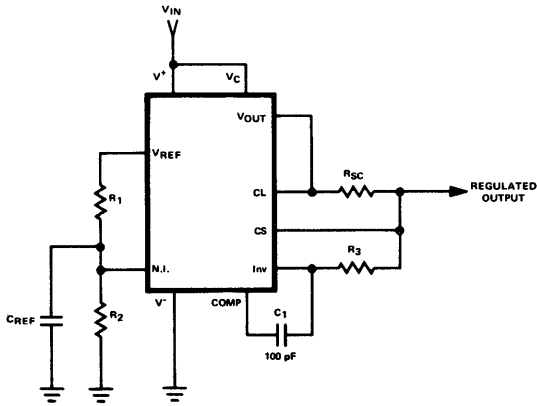

$$V_{out} = \left[ V_{REF} \times \frac{R_2}{R_1 + R_2} \right]$$

$$R_3 = \frac{R_1 R_2}{R_2 + R_2} \text{ for minimum temperature drift}$$

FIGURE 3

**NEGATIVE VOLTAGE REGULATOR**

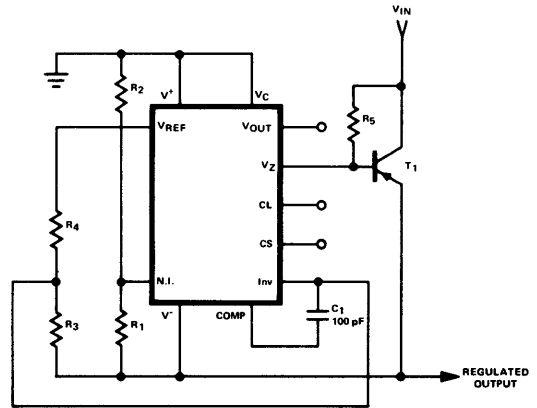

$$V_{out} = \left[ \frac{V_{REF}}{2} \times \frac{R_1 + R_2}{R_1} \right] ; R_3 = R_4$$

FIGURE 4

**FOLDBACK CURRENT LIMITING REGULATOR**  
( $V_{out} = 2$  to 7 Volts)

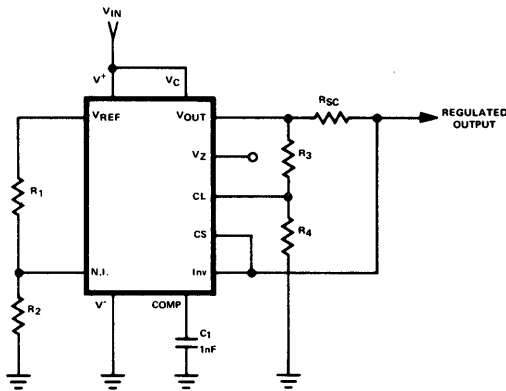

$$I_{KNEE} = \left[ \frac{V_{out} R_3}{R_{sc} R_4} + \frac{V_{SENSE} (R_3 + R_4)}{R_{sc} R_4} \right]$$

$$V_{out} = \left[ V_{REF} \times \frac{R_1 + R_2}{R_2} \right]$$

$$I_{SHORT\ CKT} = \left[ \frac{V_{SENSE}}{R_{sc}} \times \frac{R_3 + R_4}{R_4} \right]$$

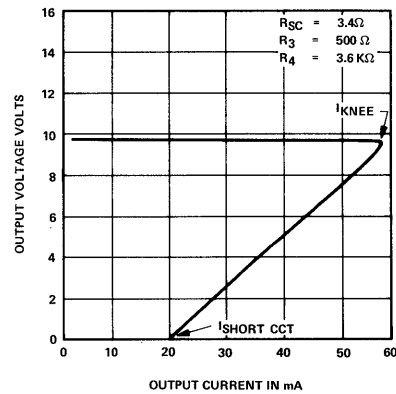

$$\frac{R_4}{R_3} = \frac{V_{OUT} I_{SC}}{V_{SENSE} (I_{KNEE} - I_{SHORTCCT})} - 1$$

$$R_{SC} = \frac{V_{SENSE}}{I_{SC}} \left[ 1 + \frac{R_3}{R_4} \right]$$

FIGURE 5

# BIPOLAR DIGITAL

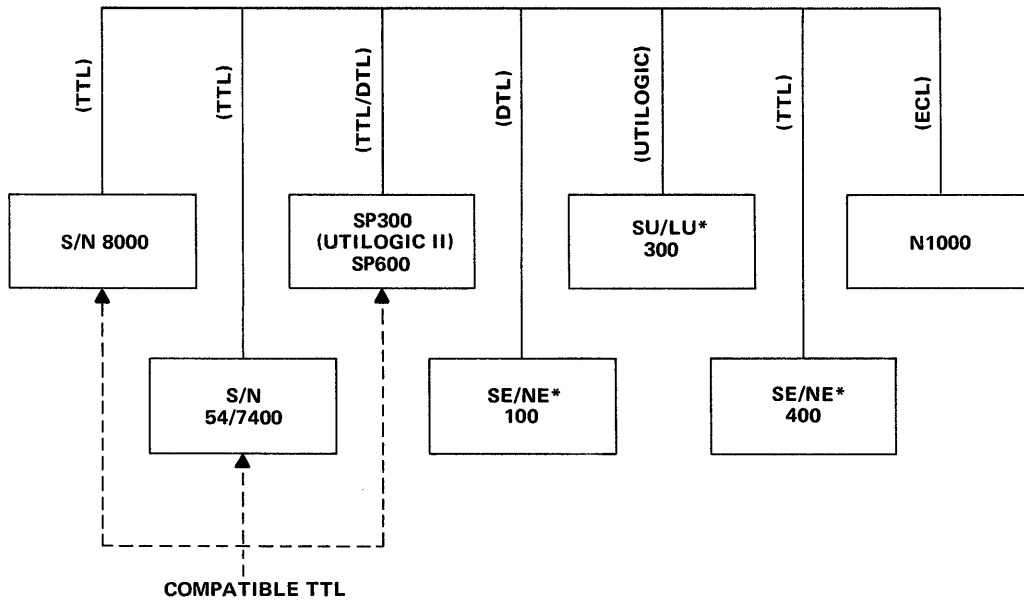

\*NOTE: Information pertaining to these Signetics series product lines may be obtained by contacting your local sales representative.

## 8000 SERIES

The concept of cross-family compatibility in integrated circuits was born in 1966 when Signetics introduced Designer's Choice Logic (DCL). This family consists of the following compatible sub-families:

<b>8100</b>	Special purpose sub-systems.
<b>8200</b>	Integrated monolithic sub-systems (MSI).
<b>8400</b>	Offers DTL logic flexibility at lower power consumption and higher fan-out than any other DTL family.
<b>8800</b>	The classical high level TTL circuit design is utilized to provide low propagation delays and high noise immunity.
<b>8H00</b>	A higher speed version of the 8800.
<b>8T00</b>	A group of interface elements which includes voltage level translators, line drivers and receivers, and Display (Nixie* and Seven Segment) Drivers.

8000 series devices are available in military and commercial temperature ranges and a wide variety of package types.

**SECTION 5**  
**comparators and sense amplifiers**





## LINEAR INTEGRATED CIRCUITS

### DESCRIPTION

The Signetics 518 is a medium-gain, high frequency differential amplifier fabricated within a monolithic silicon substrate by planar and epitaxial techniques. It is designed for voltage comparator, sense amplifier and general broadband amplifier applications. Its superior current sinking and current sourcing capabilities make it ideal for driving digital circuitry.

### FEATURES

- STROBE CONTROL
- ADJUSTABLE CURRENT SINK
- RESPONSE TIME = NE 60ns  
SE 55ns
- INPUT OFFSET VOLTAGE = 1.0mV
- OPEN LOOP GAIN = NE 1800  
SE 2100
- OUTPUT IMPEDANCE = 50Ω
- BANDWIDTH = 5.0MHz

### ABSOLUTE MAXIMUM RATINGS

Voltage Applied (Positive)	+8.0V
Voltage Applied (Negative)	-4.0V
Voltage Applied (Input)	±5.0V
Power Consumption	300mW
Power Supply Current Rating	-25mA
Output Source Current	20mA
Storage Temperature	-65°C to +150°C
Operating Temperature	NE 0°C to +70°C SE -55°C to +125°C

### CIRCUIT SCHEMATIC

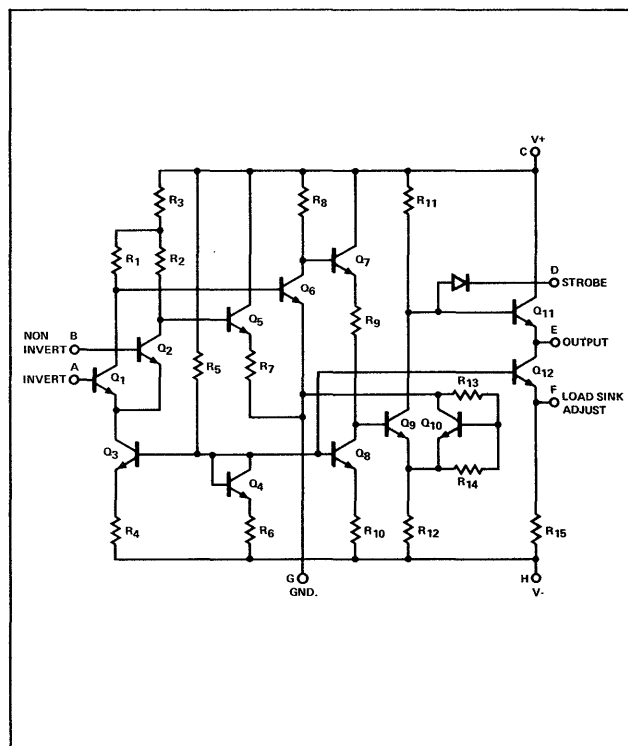

### PIN CONFIGURATIONS

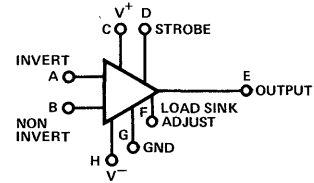

### A PACKAGE (Top View)

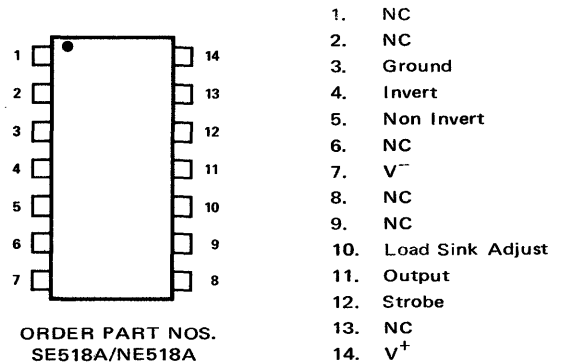

### G PACKAGE

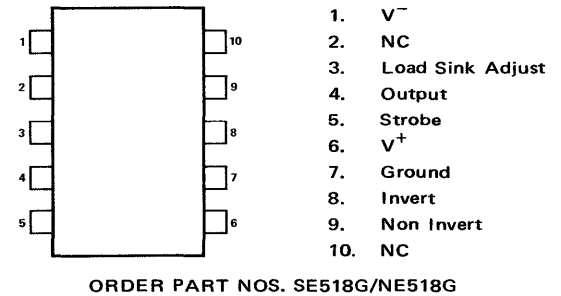

### K PACKAGE

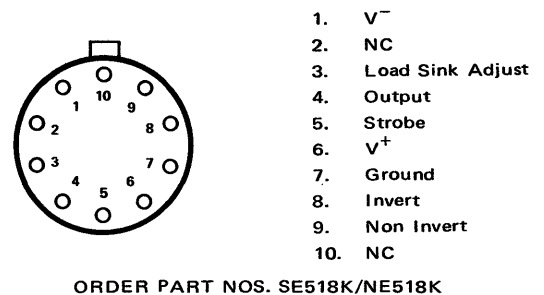

**ELECTRICAL CHARACTERISTICS** (Standard Conditions:  $V_+ = +6.0V$ ,  $V_- = -3.0V$ ; Note 1)

CHARACTERISTICS	TEST CONDITIONS	NE518				SE518				UNITS
		MIN	TYP.	MAX.	TEMP.	MIN.	TYP.	MAX.	TEMP.	
INPUT OFFSET VOLTAGE	$V_E = 1.0V$ , $V_B = 0V$ , Note 5		1.0	4.0	0°C		1.0	4.0	-55°C	mV
				3.5	+25°C			3.0	+25°C	mV
				4.0	+70°C			4.0	+125°C	mV
VARIATION OF INPUT OFFSET VOLTAGE WITH TEMPERATURE	Note 7			1.0	0°C			1.5	-55°C	mV
				1.0	+70°C			1.5	+125°C	mV
INPUT BIAS CURRENT	$V_A = V_B = 0V$			70	0°C			70	-55°C	μA
			35	50	+25°C		28	35	+25°C	μA
INPUT OFFSET CURRENT	$V_A = V_B = 0V$			12	0°C			12	-55°C	μA
			3	9	+25°C		2.0	6.0	+25°C	μA
TURN ON DELAY TIME	Notes 3, 4		45	60	+25°C		40	50	+25°C	ns
RISE TIME	Notes 3, 4		15	25	+25°C		12	20	+25°C	ns
TURN OFF DELAY TIME	Notes 3, 4		45	60	+25°C		40	50	+25°C	ns
FALL TIME	Notes 3, 4		30	40	+25°C		25	35	+25°C	ns
OPEN LOOP BANDWIDTH (-3dB)			5.0		+25°C		5.0		+25°C	mHz
OPEN LOOP VOLTAGE GAIN		1200			0°C	1200			-55°C	V/V
		1375	1800		+25°C	1600	2100		+25°C	V/V
		1375			+70°C	1600			+125°C	V/V
OUTPUT VOLTAGE SWING (Positive)	$V_A = -0.1V$ , $V_B = 0V$	4.6			0°C	4.6			-55°C	V
		4.8	5.0		+25°C	4.9	5.1		+25°C	V
OUTPUT VOLTAGE SWING (Negative)	$V_A = +0.1V$ , $V_B = 0V$	-1.5			0°C	-1.5			-55°C	V
		-1.2	-1.4		+25°C	-1.2	-1.4		+25°C	V
		-0.8			+70°C	-0.8			+125°C	V
OUTPUT IMPEDANCE	$f \leq 10kHz$		50		+25°C		50		+25°C	Ω
OUTPUT SINK CURRENT	$V_A = +0.1V$ , $V_B = 0V$ Note 2 $R_L = 150\Omega$	2.2	2.8		+25°C	2.2	2.8		+25°C	mA
OUTPUT SOURCE CURRENT	$V_A = -0.1V$ , $V_B = 0V$ Note 2 $R_L = 150\Omega$	-15	-18		+25°C	-18	-20		+25°C	mA
STROBE ON CURRENT	$V_D = V_B = 0V$ , $V_A = -0.1V$		-4.0	-4.75	+25°C		-3.8	-4.6	+25°C	mA
STROBE LEAKAGE CURRENT	$V_D = 6.0V$ , $V_A = +0.1V$ , $V_B = 0V$		1.0	10	+70°C		1.0	10	+125°C	μA
DIFFERENTIAL INPUT IMPEDANCE	$f \leq 10kHz$		1400		+25°C		2000		+25°C	Ω
COMMON MODE REJECTION RATIO	Note 6		80		+25°C		80		+25°C	dB
POWER SUPPLY CURRENT	$V_A = V_B = 0V$		19	27	+25°C		19	25	+25°C	mA

NOTES

Letter subscripts refer to pins on circuit schematic.

- All voltages are referenced to Pin G.
- $R_L$  must be connected between Pins E and G. Output sink current capability may be increased up to 10mA by connecting an external resistor between Pins H and F.
- Differential Overdrive Voltage = 10mV.
- $t_{d1}$  and  $t_{d2}$  are measured from 80% point of input pulse to 20% point of output pulse.  $t_r$  and  $t_f$  are measured from 20% to 80% of output pulse.
- Input offset voltage may be (+) or (-), Pin A with respect to Pin B.
- Measured at a common mode voltage of +1.0VDC.
- Variation from room temperature value.
- See Signetics Bulletin No. 5001 for details of acceptance tests under Signetics SURE Program.
- Positive current flow is defined as into the terminal referenced.
- Precautionary measures should be taken to ensure current limiting in accordance with maximum ratings should the isolation diodes become forward biased.



## LINEAR INTEGRATED CIRCUITS

### DESCRIPTION

The 526 is a high speed analog comparator intended for use in systems where low propagation delay and fast recovery from common mode or differential input overdrive is required. The device is specifically designed to provide a wide input common mode range while operating from power supplies commonly found in digital logic systems.

The 526 consists of a medium gain, high frequency differential amplifier and a high speed TTL gate fabricated within a single substrate by planar and epitaxial techniques. The output gate of the 526 has voltage and current capabilities compatible with DCL, DTL and TTL. The 526 output gate has a full fan-out of 10 to standard TTL loads.

The amplifier and gate may be used independently or cascaded for applications as a voltage comparator, digital line receiver or sense amplifier. The second gate input is used to provide strobe capability when operating the amplifier and gate in cascade.

### FEATURES

- PROPAGATION DELAY 30ns
- INPUT COMMON MODE RANGE +4.5V  
-3.5V
- DIFFERENTIAL OVERDRIVE RECOVERY 20ns
- OUTPUT COMPATIBLE WITH STANDARD LOGIC FORMS
- OPERATES FROM STANDARD  $\pm 5V$  SUPPLIES

### ABSOLUTE MAXIMUM RATINGS

Supply Voltage	+7.0V
Gate Input Voltage	+6.0V
Differential Input Voltage	+5.0V
Common Mode Input Voltage	+5.0V
Gate Output Current	+100 mA
Storage Temperature	-65°C to +150°C
Operating Temperature	SE526 -55°C to +125°C NE526 0°C to +75°C

Absolute Maximum Ratings are limiting values above which serviceability may be impaired.

### PIN CONFIGURATION

#### A PACKAGE

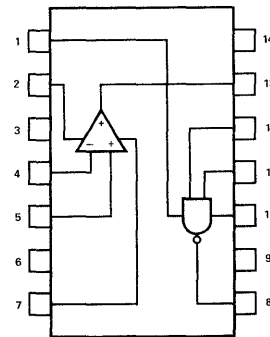

1.  $V_2^+$
2.  $V_1^+$
3. NC
4.  $V_{IN}$
5.  $V_{IN}$
6. NC
7.  $V^-$
8.  $V_o$
9. NC
10. Ground
11.  $V_{IN}$
12.  $V_{IN}$
13.  $e_o$
14. NC

ORDER PART NOS.  
SE526A/NE526A

#### G PACKAGE

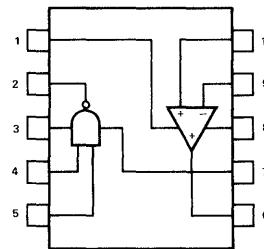

1.  $V_1^-$
2.  $V_o$
3. Ground
4.  $V_{IN}$
5.  $V_{IN}$
6.  $e_{o+}$
7.  $V_2^+$
8.  $V_1^+$
9.  $e_{in}$
10.  $e_{in}$

ORDER PART NOS.  
SE526G/NE526G

#### K PACKAGE

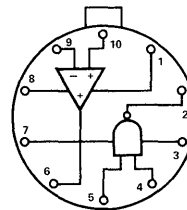

1.  $V_1^-$
2.  $V_o$
3. Ground
4.  $V_{IN}$
5.  $V_{IN}$
6.  $e_{o+}$
7.  $V_2^+$
8.  $V_1^+$
9.  $e_{in}$
10.  $e_{in}$

ORDER PART NOS.  
SE526K/NE526K

**SIGNETICS ■ 526 — HIGH SPEED ANALOG VOLTAGE COMPARATOR**

**ELECTRICAL CHARACTERISTICS** (Standard Conditions:  $V_1^+ = V_2^+ = 5.0V$ ,  $V^- = -5.0V$ ; Notes 1,2,3,4,13,14)

CHARACTERISTIC	SYMBOL	LIMITS				TEMPERATURE		NOTES
		MIN.	TYP.	MAX.	UNIT	SE526	NE526	
Input Offset Voltage	$V_{io}$		2.0	5.0	mV	-55°C	0°C	5
	$V_{io}$		2.0	5.0	mV	+25°C	+25°C	5
	$V_{io}$		2.0	5.0	mV	+125°C	+75°C	5
Input Bias Current	$I_{in}$		30.0	35.0	$\mu A$	-55°C	0°C	6
	$I_{in}$		25.0	35.0	$\mu A$	+25°C	+25°C	6
	$I_{in}$		22.0	35.0	$\mu A$	+125°C	+75°C	6
Input Offset Current	$I_{io}$		0.6	5.0	$\mu A$	-55°C	0°C	
	$I_{io}$		0.5	5.0	$\mu A$	+25°C	+25°C	
	$I_{io}$		0.4	5.0	$\mu A$	+125°C	+75°C	
Input Common Mode Range	$V_{cm}$	+4.2	+4.7		V	-55°C	0°C	
	$V_{cm}$	+4.2	+4.5		V	+25°C	+25°C	
	$V_{cm}$	+4.2	+4.4		V	+125°C	+75°C	
	$V_{cm}$	-3.2	-3.5		V	-55°C	0°C	
	$V_{cm}$	-3.2	-3.5		V	+25°C	+25°C	
	$V_{cm}$	-3.2	-3.5		V	+125°C	+75°C	
Amplifier Output Voltage	$V_{ohi}$	3.5			V	-55°C	0°C	
	$V_{ohi}$	3.5			V	+25°C	+25°C	
	$V_{ohi}$	3.5			V	+125°C	+75°C	
	$V_{olo}$			0.6	V	-55°C	0°C	
	$V_{olo}$			0.5	V	+25°C	+25°C	
	$V_{olo}$			0.4	V	+125°C	+75°C	
Amplifier Power Consumption	$P_d$		90	120	mV	-55°C	0°C	
	$P_d$		100	120	mV	+25°C	+25°C	
	$P_d$		110	120	mV	+125°C	+75°C	
Gate Output Voltage	$V1_o$	2.8	3.5		V	-55°C	0°C	7, 8
	$V1_o$	2.8	3.2		V	+25°C	+25°C	7, 8
	$V1_o$	2.8	3.0		V	+125°C	+75°C	7, 8
	$V0_o$		0.3	0.4	V	-55°C	0°C	7, 8
	$V0_o$		0.2	0.4	V	+25°C	+25°C	7, 8
	$V0_o$		0.3	0.4	V	+125°C	+75°C	7, 8
Gate Output Sink Current	$I0_o$	16.0			mA	+25°C	+25°C	8
Gate Output Source Current	$I1_o$	1.0			mA	+25°C	+25°C	7
Gate Input Threshold Voltage	$V1_i$	2.0			V	-55°C	0°C	9
	$V1_i$	2.0			V	+25°C	+25°C	9
	$V1_i$	2.0			V	+125°C	+75°C	9
	$V0_i$			1.0	V	-55°C	0°C	10
	$V0_i$			0.9	V	+25°C	+25°C	10
	$V0_i$			0.8	V	+125°C	+75°C	10
Gate Input Current (Input "0")	$I0_i$	-0.1	-1.2	-1.6	mA	-55°C	0°C	
	$I0_i$	-0.1	-1.4	-1.6	mA	+25°C	+25°C	
	$I0_i$	-0.1	-1.2	-1.6	mA	+125°C	+75°C	
	(Input "1")		5	25	$\mu A$	-55°C	0°C	
			10	25	$\mu A$	+25°C	+25°C	
			15	25	$\mu A$	+125°C	+75°C	
Gate Current Consumption (Output "1")	$I_{CC1}$			2.00	mA	-55°C	0°C	
	$I_{CC1}$			2.00	mA	+25°C	+25°C	
	$I_{CC1}$			2.00	mA	+125°C	+75°C	
	(Output "0")			5.00	mA	-55°C	0°C	
				5.00	mA	+25°C	+25°C	
				5.00	mA	+125°C	+75°C	
Gate Input Latch Voltage Rating	$BV_i$			6.0	V	+25°C	+25°C	
Gate Output Short Circuit Current	$I_{so}$	-10.0		-70.0	mA	+25°C	+25°C	
Switching Times	Gate Turn-On Delay	$T_{on}$	15	17	ns	+25°C	+25°C	11
	Gate Turn-Off Delay	$T_{off}$	15	17	ns	+25°C	+25°C	11
	Propagation Delay	$T_{pd0}$	30	42	ns	+25°C	+25°C	11
	Propagation Delay	$T_{pd1}$	40	48	ns	+25°C	+25°C	11
	Differential Overload Recovery	$t_{dm}$	30	40	ns	+25°C	+25°C	11, 12

Recommended Operating Supply Voltages ( $V_1^+ = V_2^+ = 5.0V$ ,  $V^- = -5.0V$ )

- NOTES:**
- All measurements are referenced to the ground terminal.
  - Positive current is defined as into the pin referenced.
  - Pins not specifically referenced are left electrically open.
  - Precautionary measures should be taken to ensure current limiting in accordance with Absolute Maximum Ratings should the isolation diodes become forward biased.
  - Input Offset Voltage is tested at guaranteed Input Common Mode Range voltage limits and includes the worst-case variations of voltage gain and input impedance. These are the maximum values required to drive the output down to "0" or up to "1".
  - Input Bias Current is defined as the maximum current required to bias either input.
  - Output source current is supplied through a resistor to ground.
  - Output sink current is supplied through a resistor to  $V_2^+$ .
  - These limits are guaranteed by Gate Output Voltage ( $V0_o$ ) test.
  - These limits are guaranteed by Gate Output Voltage ( $V1_o$ ) tests.
  - Load capacitance includes test fixture and probe capacitance.
  - Differential Input Voltage = 500mV for this test.
  - Acceptance Test Subgroup A-7 provides end point parameters for linear devices processed to Signetics SURE Program. See Signetics SURE Bulletin 5001.
  - Manufacturer reserves the right to make design and process changes and improvements.



## LINEAR INTEGRATED CIRCUITS

### DESCRIPTION

The SE/NE 527 is a high speed analog voltage comparator which, for the first time mates state-of-the-art Schottky diode technology with the conventional linear process. This allows simultaneous fabrication of high speed T<sup>2</sup>L gates with a precision linear amplifier on a single monolithic chip.

The SE/NE 527 is similar in design to the Signetics SE/NE 529 voltage comparator except that it incorporates a "Emitter Follower" input stage for extremely low input currents. This opens the door to a whole new range of applications for analog voltage comparators.

### FEATURES

- 15 nsec PROPAGATION DELAY
- COMPLEMENTARY OUTPUT GATES
- TTL OR ECL COMPATIBLE OUTPUTS
- WIDE COMMON MODE AND DIFFERENTIAL VOLTAGE RANGE

### APPLICATIONS

- A/D CONVERSION
- ECL TO TTL INTERFACE
- TTL TO ECL INTERFACE
- MEMORY SENSING
- OPTICAL DATA COUPLING

### BLOCK DIAGRAM

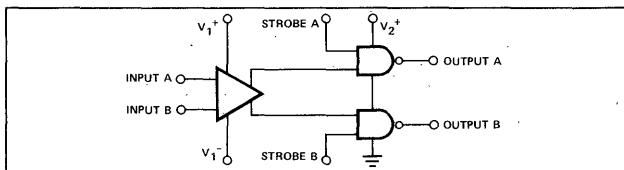

### EQUIVALENT CIRCUIT

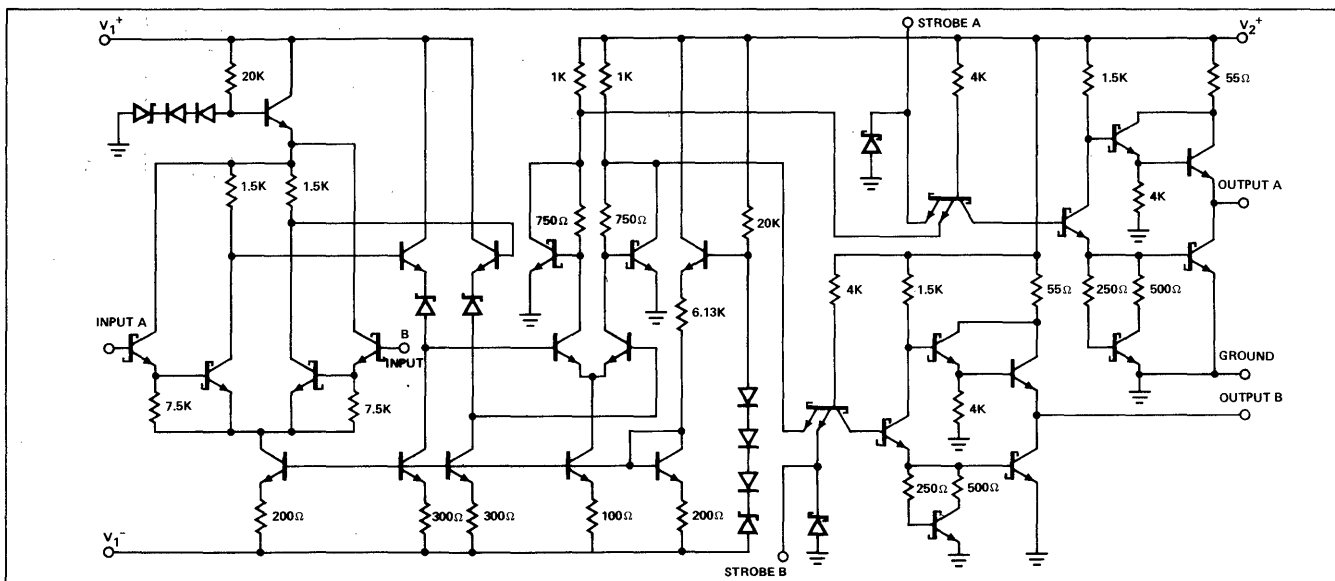

### PIN CONFIGURATION

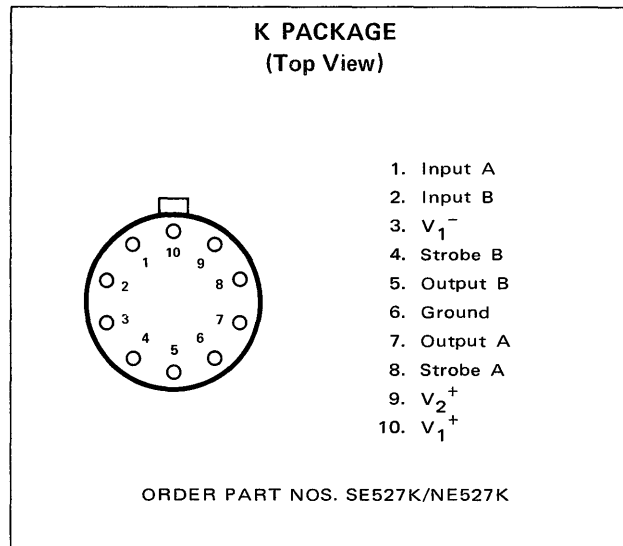

### ABSOLUTE MAXIMUM RATINGS

Positive Supply Voltage ( $V_1^+$ )	+15 volts
Negative Supply Voltage ( $V_1^-$ )	-15 volts
Gate Supply Voltage ( $V_2^+$ )	+7 volts
Output Voltage	+15 volts
Differential Input Voltage	±5 volts
Input Common Mode Voltage	±6 volts
Power Dissipation	600mW
Operating Temperature Range	
NE 527	0°C to +70°C
SE 527	-55°C to +125°C
Storage Temperature Range	-65°C to +150°C
Lead Temperature (Soldering 60 seconds)	+300°C

**SIGNETICS ■ 527 – ANALOG VOLTAGE COMPARATOR**

**ELECTRICAL CHARACTERISTICS ( $V_1^+ = +10V, V_1^- = -10V, V_2^+ = +5.0V, V_{in} = 0V$ )**

PARAMET	TEST CONDITIONS	SE 527			NE 527			UNITS
		MIN	TYP	MAX	MIN	TYP	MAX	
<b>INPUT CHARACTERISTICS</b>								
Input Offset Voltage @25°C over temperature range				4 6			6 10	mV mV
Input Bias Current @25°C over temperature range	$V_1^+ = 10V, V_1^- = -10V$ $V_{in} = 0V$			2 4			2 4	$\mu A$ $\mu A$
Input Offset Current @25°C over temperature range	$V_1^+ = 10V, V_1^- = -10V$ $V_{in} = 0V$			0.5 1			0.75 1	$\mu A$ $\mu A$
Voltage Gain	$T_A = 25^\circ C$		5			5		V/mV
Input Resistance	$T_A = 25^\circ C, f = 1 \text{ kHz}$		500			500		$K\Omega$
<b>GATE CHARACTERISTICS</b>								
Output Voltage								
"1" State	$V_2^+ = 4.75V, I_{source} = -1mA$	2.5	3.3		2.7	3.3		V
"0" State	$V_2^+ = 4.75V, I_{sink} = 10mA$			0.5			0.5	V
Strobe Inputs								
"0" Input Current	$V_2^+ = 5.25V, V_{strobe} = 0.5V$			-2			-2	mA
"1" Input Current @25°C over temperature range	$V_2^+ = 5.25V, V_{strobe} = 2.7V$			50 200			100 200	$\mu A$ $\mu A$
"0" Input Voltage	$V_2^+ = 4.75V$			0.8			0.8	V
"1" Input Voltage	$V_2^+ = 4.75V$	2.0			2.0			V
Short Circuit Output Current	$V_2^+ = 5.25V, V_{out} = 0V$	-40		-100	-40		-100	mA
<b>POWER SUPPLY REQUIREMENTS</b>								
Supply Voltage								
$V_1^+$		5		10	5		10	V
$V_1^-$		-6		-10	-6		-10	V
$V_2^+$		4.5	5	5.5	4.75	5	5.25	V
Supply Current								
$I_1^+$	$V_1^+ = 10V, V_1^- = -10V$ $V_2^+ = 5.25V$ $T_A = 125^\circ C$ $T_A = 25^\circ C$ $T_A = -55^\circ C$ $0^\circ C \leq T_A \leq 70^\circ C$			3.25 3.75 4.0			5	mA mA mA mA
$I_1^-$	$T_A = 125^\circ C$ $T_A = 25^\circ C$ $T_A = -55^\circ C$ $0^\circ C \leq T_A \leq 70^\circ C$			7.0 7.5 8.5			10	mA mA mA mA
$I_2^+$	$T_A = 125^\circ C$ $T_A = 25^\circ C$ $T_A = -55^\circ C$ $0^\circ C \leq T_A \leq 70^\circ C$			15 16 18			20	mA mA mA mA
<b>TRANSIENT RESPONSE</b>								
Propagation Delay Time								
$t_{pd} (0)$	$T_A = +25^\circ C$		14		14			ns
$t_{pd} (1)$	$T_A = +25^\circ C$		16		16			ns
Delay between Output A and B	$T_A = +25^\circ C$		2		2			ns
Strobe Delay Time								
Turn On	$T_A = +25^\circ C$		6		6			ns
Turn Off	$T_A = +25^\circ C$		6		6			ns

Parameters are guaranteed over the temperature range unless otherwise noted.

**APPLICATIONS**

One of the main features of the device is that supply voltages ( $V_{1+}$ ,  $V_{1-}$ ) need not be balanced, as indicated in the following diagrams. For proper operation, however, negative supply ( $V_{1-}$ ) should always be at least six volts more negative than the ground terminal (pin 6). Input Common Mode range should be limited to values

of two volts less than the supply voltages ( $V_{1+}$  and  $V_{1-}$ ) up to a maximum of  $\pm 6$  volts as supply voltages are increased.

It is also important to note that Output A is in phase with Input A and Output B is in phase with Input B.

**TYPICAL APPLICATIONS**

**PHOTODIODE DETECTOR**

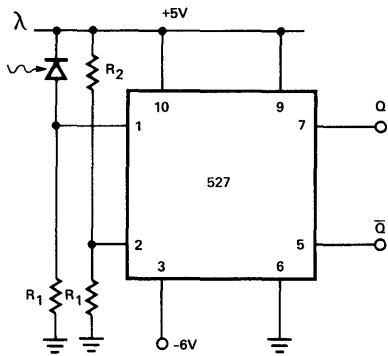

**ECL TO TTL INTERFACE**

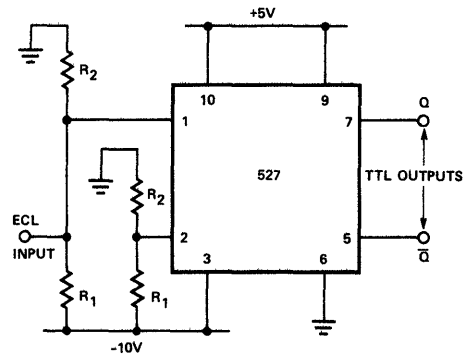

**MOS MEMORY SENSE AMP.**

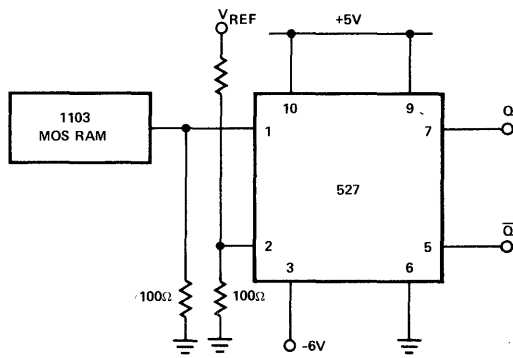

**TTL TO ECL INTERFACE**

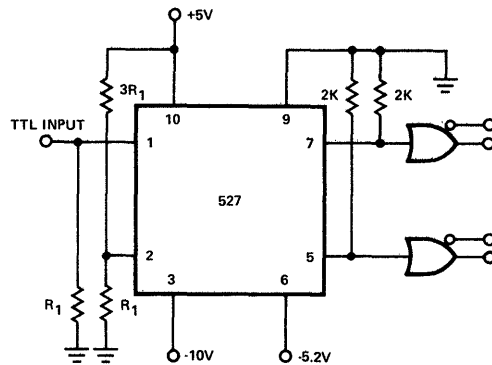



TYPICAL PERFORMANCE CURVES

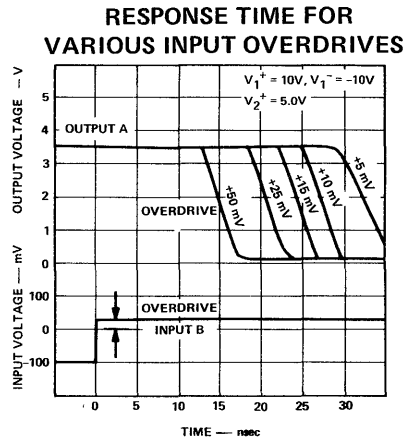
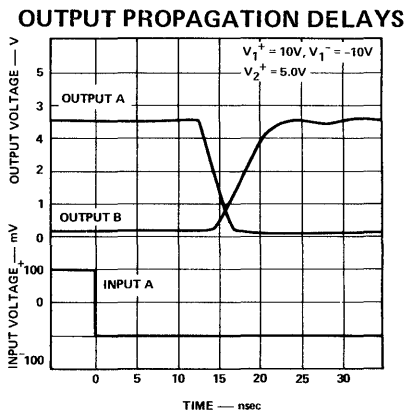
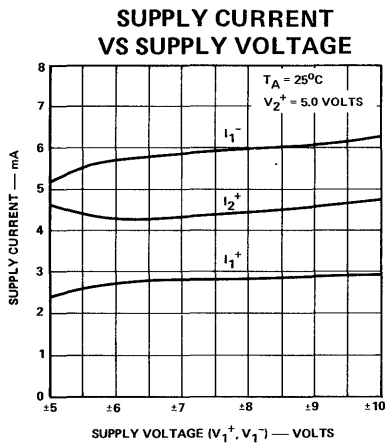
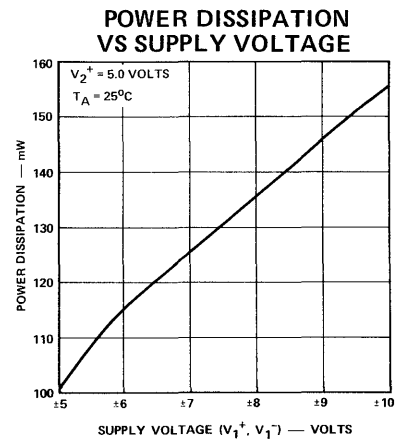
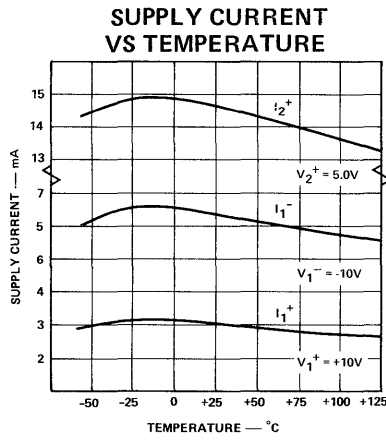
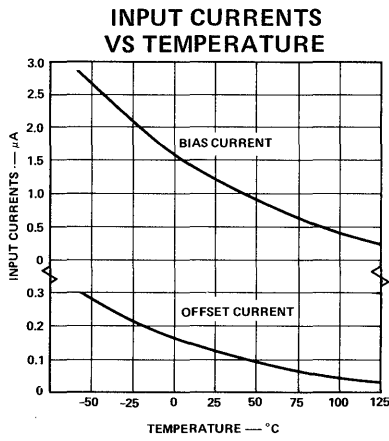

## LINEAR INTEGRATED CIRCUITS

### DESCRIPTION

The SE/NE 529 is a high speed analog voltage comparator which, for the first time mates state-of-the-art Schottky diode technology with the conventional linear process. This allows simultaneous fabrication of high speed T<sup>2</sup>L gates with a precision linear amplifier on a single monolithic chip.

### FEATURES

- 10 nsec PROPAGATION DELAY
- COMPLEMENTARY OUTPUT GATES
- TTL OR ECL COMPATIBLE OUTPUTS
- WIDE COMMON MODE AND DIFFERENTIAL VOLTAGE RANGE

### APPLICATIONS

- A/D CONVERSION
- ECL TO TTL INTERFACE
- TTL TO ECL INTERFACE
- MEMORY SENSING
- OPTICAL DATA COUPLING

### BLOCK DIAGRAM

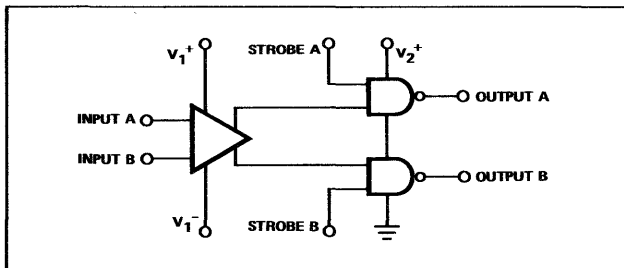

### EQUIVALENT CIRCUIT

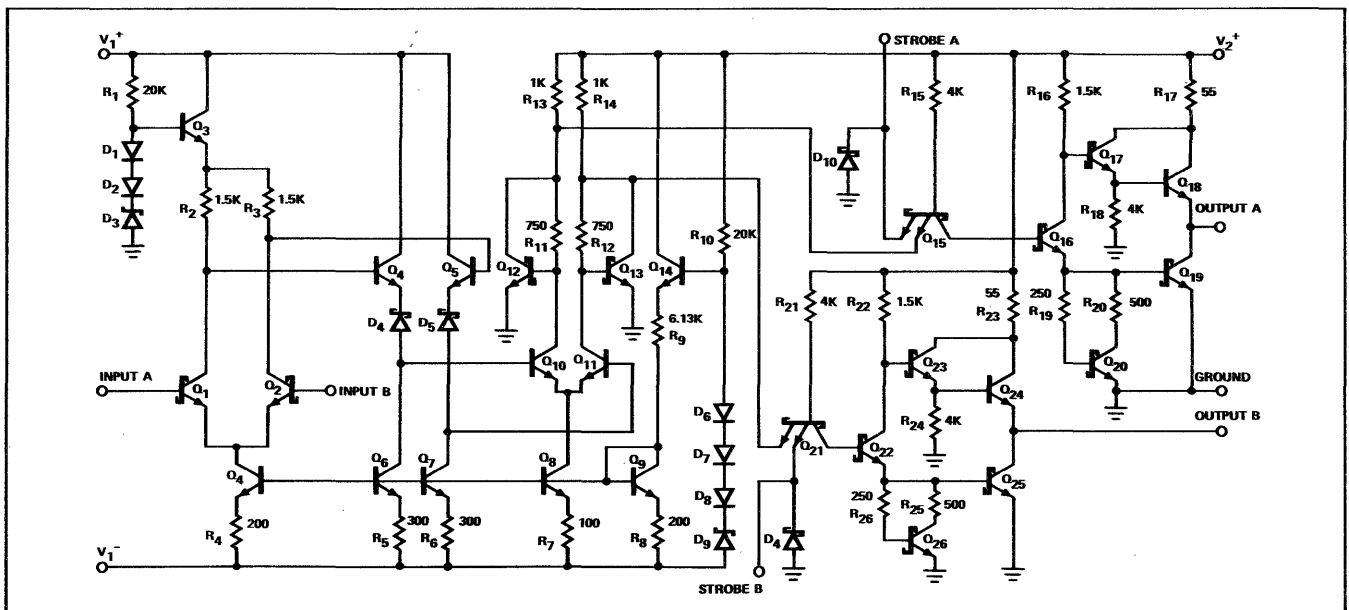

### PIN CONFIGURATION

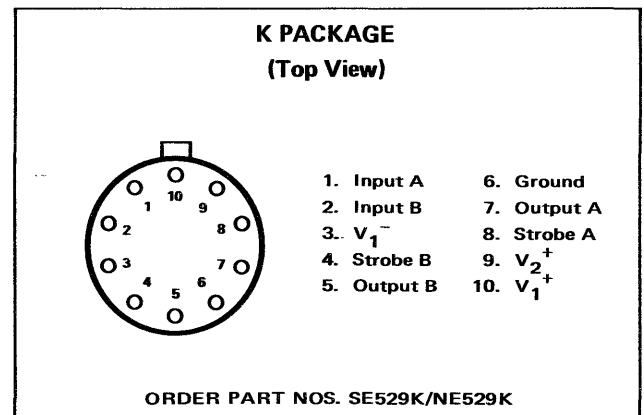

### ABSOLUTE MAXIMUM RATINGS

Positive Supply Voltage (V <sub>1</sub> <sup>+</sup> )	+15 volts
Negative Supply Voltage (V <sub>1</sub> <sup>-</sup> )	-15 volts
Gate Supply Voltage (V <sub>2</sub> <sup>+</sup> )	+7 volts
Output Voltage	+15 volts
Differential Input Voltage	±5 volts
Input Common Mode Voltage	±6 volts
Power Dissipation	600mW
Operating Temperature Range	

NE 529	0°C to +70°C
SE 529	-55°C to +125°C

Storage Temperature Range	-65°C to +150°C
Lead Temperature (Soldering 60 seconds)	+300°C

**SIGNETICS ■ 529 — ANALOG VOLTAGE COMPARATOR**

**ELECTRICAL CHARACTERISTICS** ( $V_1^+ = +10V, V_2^+ = +5.0V, V_1^- = -10V, V_{in} = 0V$ )

PARAMETER	TEST CONDITIONS	SE 529			NE 529			UNITS
		MIN	TYP	MAX	MIN	TYP	MAX	
<b>INPUT CHARACTERISTICS</b>								
Input Offset Voltage @25°C				4			6	mV
over temperature range				6			10	mV
Input Bias Current @25°C	$V_1^+ = 10V, V_1^- = -10V$		5	12		5	20	$\mu A$
over temperature range	$V_{in} = 0V$			36			50	$\mu A$
Input Offset Current @25°C	$V_1^+ = 10V, V_1^- = -10V$		2	3		2	5	$\mu A$
over temperature range	$V_{in} = 0V$			9			15	$\mu A$
Voltage Gain	$T_A = 25^\circ C$		5			5		V/mV
Input Resistance	$T_A = 25^\circ C, f = 1\text{ kHz}$		10			10		$k\Omega$
<b>GATE CHARACTERISTICS</b>								
<b>Output Voltage</b>								
"1" State @25°C	$V_2^+ = 4.75V, I_{source} = -1mA$	2.5	3.3		2.7	3.3		V
"0" State @25°C	$V_2^+ = 4.75V, I_{sink} = 10mA$			0.5			0.5	V
<b>Strobe Inputs</b>								
"0" Input Current	$V_2^+ = 5.25V, V_{strobe} = 0.5V$			-2			-2	mA
"1" Input Current @25°C				50			100	$\mu A$
over temperature range	$V_2^+ = 5.25V, V_{strobe} = 2.7V$			200			200	$\mu A$
"0" Input Voltage	$V_2^+ = 4.75V$			0.8			0.8	V
"1" Input Voltage	$V_2^+ = 4.75V$	2.0			2.0			V
<b>Short Circuit</b>								
Output Current	$V_2^+ = 5.25V, V_{out} = 0V$	-40		-100	-40		-100	mA
<b>POWER SUPPLY REQUIREMENTS</b>								
<b>Supply Voltage</b>								
$V_1^+$		5		10	5		10	V
$V_1^-$		-6		-10	-6		-10	V
$V_2^+$		4.5	5	5.5	4.75	5	5.25	V
<b>Supply Current</b>								
$I_1^+$	$V_1^+ = 10V, V_1^- = -10V$ $V_2^+ = 5.25V$ $T_A = 125^\circ C$			3.25				mA
	$T_A = 25^\circ C$			3.75				mA
	$T_A = -55^\circ C$			4.0				mA
	$0^\circ C \leq T_A \leq 70^\circ C$						5	mA
$I_1^-$	$T_A = 125^\circ C$			7.0				mA
	$T_A = 25^\circ C$			7.5				mA
	$T_A = -55^\circ C$			8.5				mA
	$0^\circ C \leq T_A \leq 70^\circ C$						10	mA
$I_2^+$	$T_A = 125^\circ C$			15				mA
	$T_A = 25^\circ C$			16				mA
	$T_A = -55^\circ C$			18				mA
	$0^\circ C \leq T_A \leq 70^\circ C$						20	mA
<b>TRANSIENT RESPONSE</b>								
<b>Propagation Delay Time</b>								
$t_{pd}(0)$	$T_A = +25^\circ C$		10			10		ns
$t_{pd}(1)$	$T_A = +25^\circ C$		12			12		ns
<b>Delay between Output A and B</b>								
Strobe Delay Time	$T_A = +25^\circ C$		2			2		ns
Turn On	$T_A = +25^\circ C$		6			6		ns
Turn Off	$T_A = +25^\circ C$		6			6		ns

Parameters are guaranteed over the temperature range unless otherwise noted.

**APPLICATIONS**

One of the main features of the device is that supply voltages ( $V_1^+$ ,  $V_1^-$ ) need not be balanced, as indicated in the following diagrams. For proper operation, however, negative supply ( $V_1^-$ ) should always be at least five volts more negative than the ground terminal (pin 6). Input Common Mode range should be limited to values of two

volts less than the supply voltages ( $V_1^+$  and  $V_1^-$ ) up to a maximum of  $\pm 6$  volts as supply voltages are increased.

It is also important to note that Output A is in phase with Input A and Output B is in phase with Input B.

**TYPICAL APPLICATIONS**

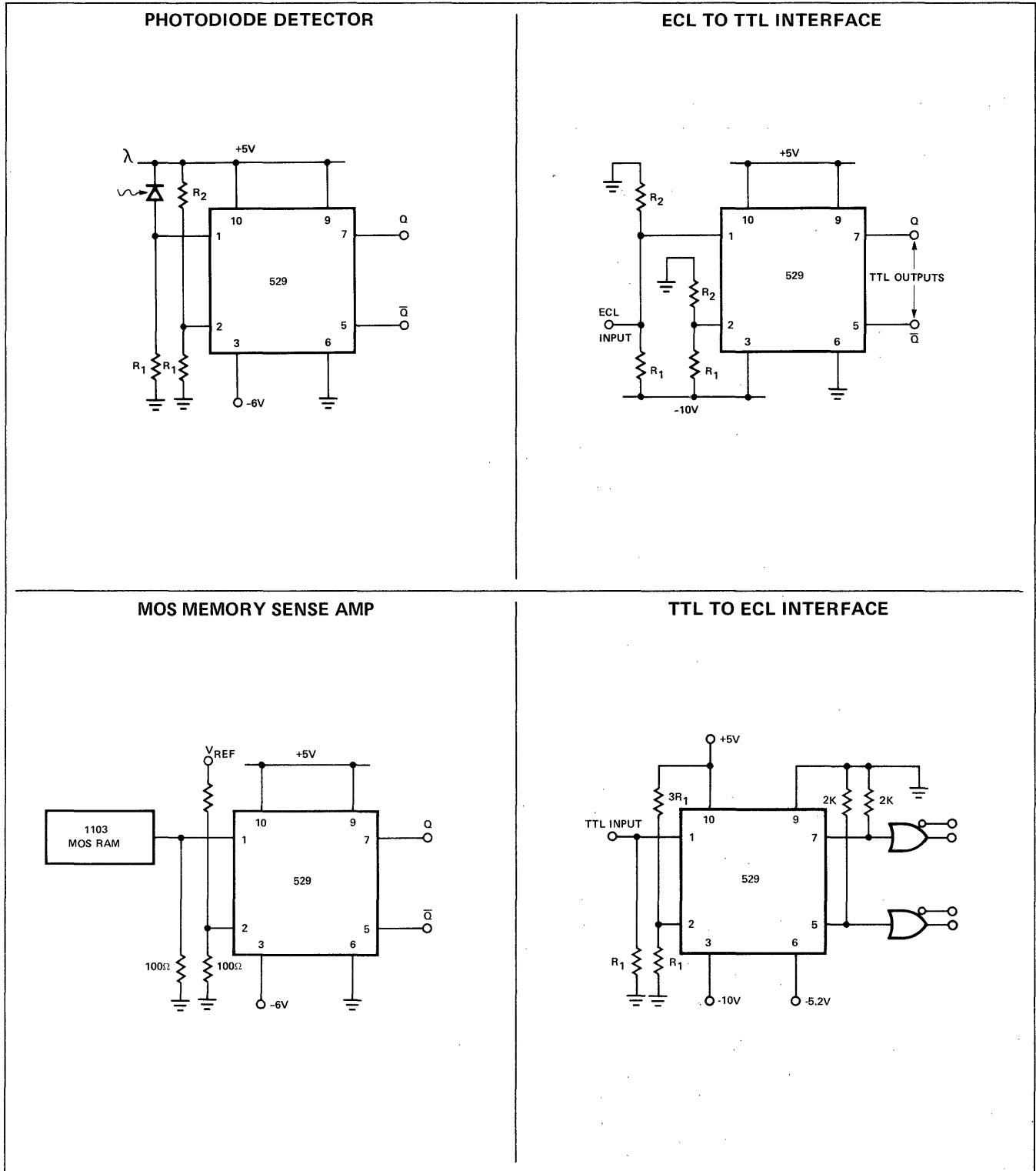

TYPICAL PERFORMANCE CURVES

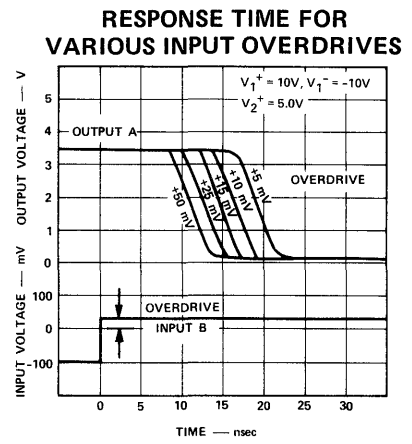
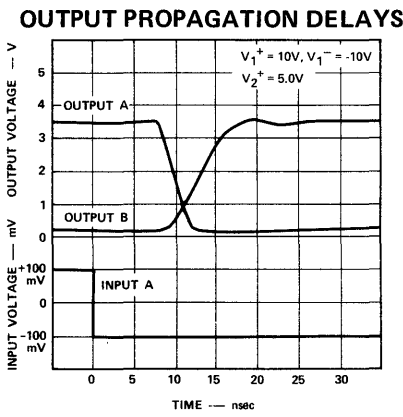
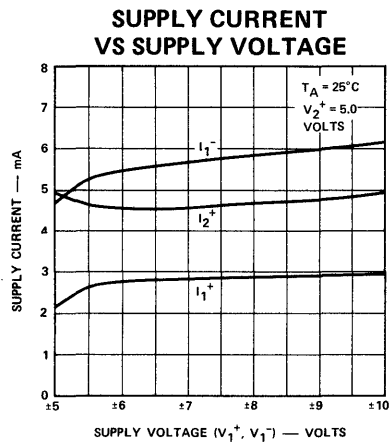
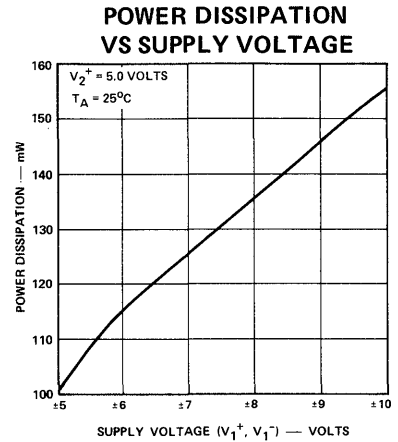
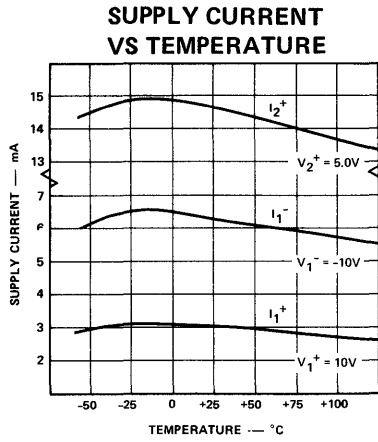
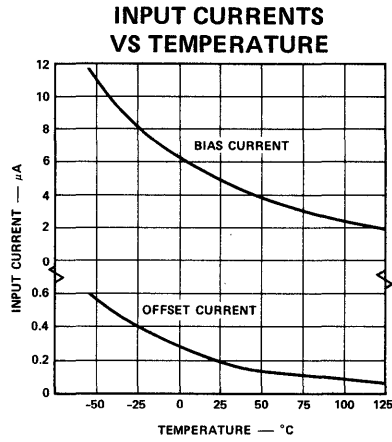

## LINEAR INTEGRATED CIRCUITS

### DESCRIPTION

The  $\mu A710$  is a High Speed Differential Voltage Comparator featuring low offset voltage, high sensitivity and a wide input voltage range. It is ideally suited for use as a pulse height discriminator, an analog comparator or a digital line receiver. The output structure of the  $\mu A710$  is compatible with DTL, TTL and Utilogic integrated circuits.

The  $\mu A710$  is specified for operation over the MIL temperature range of  $-55^{\circ}\text{C}$  to  $+125^{\circ}\text{C}$ . The  $\mu A710\text{C}$  is specified for operation over the commercial/industrial temperature range of  $0^{\circ}\text{C}$  to  $+75^{\circ}\text{C}$ .

### FEATURES

- FAST RESPONSE – 40ns
- HIGH SENSITIVITY – 1.7V/mv
- LOW OFFSET VOLTAGE TEMPERATURE COEFFICIENT –  $3.5\mu\text{V}/^{\circ}\text{C}$
- HIGH INPUT VOLTAGE RANGE –  $\pm 5.0\text{V}$

### ABSOLUTE MAXIMUM RATINGS

Positive Supply Voltage	+14.0V
Negative Supply Voltage	-7.0V
Peak Output Current	10mA
Differential Input Voltage	$\pm 5.0\text{V}$
Input Voltage	$\pm 7.0\text{V}$
Internal Power Dissipation (Note 4)	
TO-99	300mW
TO-91	200mW
Operating Temperature Range	
$\mu A710$	$-55^{\circ}\text{C}$ to $+125^{\circ}\text{C}$
$\mu A710\text{C}$	$0^{\circ}\text{C}$ to $+75^{\circ}\text{C}$
Storage Temperature Range	$-65^{\circ}\text{C}$ to $+150^{\circ}\text{C}$
Lead Temperature (Soldering, 60 sec)	$300^{\circ}\text{C}$

Maximum Ratings are limiting values above which serviceability may be impaired.

### BASIC CIRCUIT SCHEMATIC

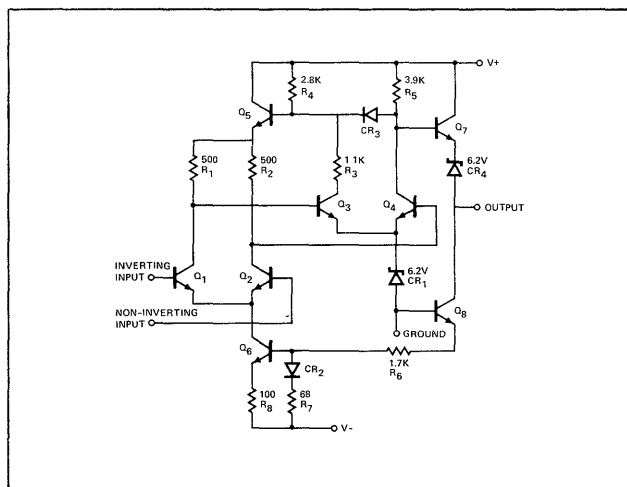

### PIN CONFIGURATION

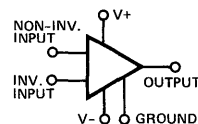

#### A PACKAGE

(Top View)

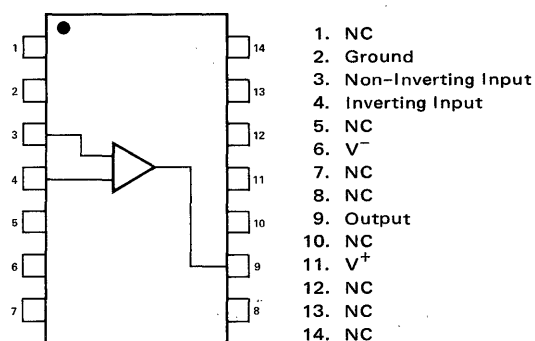

ORDER PART NOS.  $\mu A710\text{A}/\mu A710\text{CA}$

#### G PACKAGE

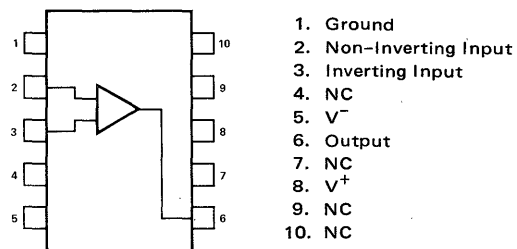

ORDER PART NOS.  $\mu A710\text{G}/\mu A710\text{CG}$

#### T PACKAGE

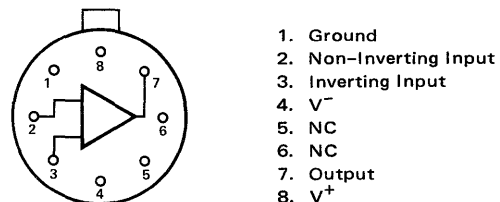

ORDER PART NOS.  $\mu A710\text{T}/\mu A710\text{CT}$

# SIGNETICS ■ $\mu$ A710 – DIFFERENTIAL VOLTAGE COMPARATOR

## ELECTRICAL CHARACTERISTICS (Note 1)

(Standard Conditions:  $T_A = +25^\circ\text{C}$ ,  $V^+ = 12\text{V}$ ,  $V^- = -6.0\text{V}$  unless otherwise specified)

PARAMETERS	TEST CONDITIONS	MIN		TYP		MAX		UNITS
		$\mu$ A710	$\mu$ A710C	$\mu$ A710	$\mu$ A710C	$\mu$ A710	$\mu$ A710C	
Input Offset Voltage	$R_S \leq 200\Omega$ Note 3			0.6	1.6	2.0	5.0	mV
Input Offset Current	Note 3			0.75	1.8	3.0	5.0	$\mu$ A
Input Bias Current				13	16	20	25	$\mu$ A
Voltage Gain		1250	1000	1700	1500			
Output Resistance				200	200			$\Omega$
Output Sink Current	$\Delta V_{in} \geq 5\text{mV}$ , $V_{out} = 0$	2.0	1.6	2.5				mA
Response Time	Note 2			40	40			ns
Except as noted, the following specifications apply over the temperature ranges of: $-55^\circ\text{C} \leq T_A \leq +125^\circ\text{C}$ for the S5710 $0^\circ\text{C} \leq T_A \leq +75^\circ\text{C}$ for the N5710								
Input Offset Voltage	$R_S \leq 200\Omega$ Note 3					3.0	6.5	
Average Temperature Coefficient of Input Offset Voltage	$R_S = 50\Omega$ , $T_A = +25^\circ\text{C}$ to $+125^\circ\text{C}$ $R_S = 50\Omega$ , $T_A = +25^\circ\text{C}$ to $-55^\circ\text{C}$ $R_S = 50\Omega$ , $T_A = 0^\circ\text{C}$ to $+75^\circ\text{C}$			3.5		10		$\mu\text{V}/^\circ\text{C}$
Input Offset Current	$T_A = +125^\circ\text{C}$ Note 3 $T_A = -55^\circ\text{C}$ $T_A = 0^\circ\text{C}$ to $+75^\circ\text{C}$			0.25		3.0		$\mu$ A
Average Temperature Coefficient of Input Offset Current	$T_A = +25^\circ\text{C}$ to $+125^\circ\text{C}$ $T_A = +25^\circ\text{C}$ to $-55^\circ\text{C}$ $T_A = +25^\circ\text{C}$ to $+75^\circ\text{C}$ $T_A = +25^\circ\text{C}$ to $0^\circ\text{C}$			5.0		25		nA/ $^\circ\text{C}$
Input Bias Current	$T_A = -55^\circ\text{C}$ $T_A = 0^\circ\text{C}$			1.8		7.0		$\mu$ A
Input Common Mode Voltage Range	$V^- = -7.0\text{V}$	$\pm 5.0$	$\pm 5.0$					V
Common Mode Rejection Ratio	$R_S \leq 200\Omega$	80	70	100	98			dB
Differential Input Voltage Range		$\pm 5.0$	$\pm 5.0$					
Voltage Gain		1000	800					
Positive Output Level	$\Delta V_{in} \geq 5\text{mV}$ , $0 \leq I_{out} \leq 5.0\text{mA}$	2.5	2.5	3.2	3.2	4.0	4.0	V
Negative Output Level	$\Delta V_{in} \geq 5\text{mV}$	-1.0	-1.0	-0.5	-0.5	0	0	V
Output Sink Current	$T_A = +125^\circ\text{C}$ , $\Delta V_{in} \geq 5\text{mV}$ , $V_{out} = 0$ $T_A = -55^\circ\text{C}$ , $\Delta V_{in} \geq 5\text{mV}$ , $V_{out} = 0$ $T_A = 0^\circ\text{C}$ to $+75^\circ\text{C}$ , $\Delta V_{in} \geq 5\text{mV}$ , $V_{out} = 0$	0.5		1.7				mA
Positive Supply Current	$V_{out} \leq 0$			5.2	5.2	9.0	9.0	mA
Negative Supply Current				4.6	4.6	7.0	7.0	mA
Power Consumption				90	90	150	150	mW

(Recommended Operating Supply Voltages:  $V^+ = 12\text{V}$ ,  $V^- = -6\text{V}$ )

### NOTES:

- All voltages are referenced to pin F.
- The response time specified is measured with a 100mV input step, and a 5mV overdrive.
- Input Offset Voltage and Input Offset Current are specified for output voltage levels of:

$\mu$ A710	$\mu$ A710C
1.8V at $-55^\circ\text{C}$	1.5V at $0^\circ\text{C}$
1.4V at $+25^\circ\text{C}$	1.4V at $+25^\circ\text{C}$
1.0V at $+125^\circ\text{C}$	1.2V at $+75^\circ\text{C}$

- Rating applies for temperatures up to:  $\mu$ A710 –  $+125^\circ\text{C}$   
 $\mu$ A710C –  $+75^\circ\text{C}$

## LINEAR INTEGRATED CIRCUITS

### DESCRIPTION

The  $\mu A711$  High Speed Dual Voltage Comparator features low offset voltage, high sensitivity and a wide input voltage range. It is ideal for use as a bi-directional limit detector in automatic test equipment.

Due to fast response and strobe control capabilities the  $\mu A711$  performs well as a sense amplifier in core memory systems.

The  $\mu A711$  is specified over the military temperature range of  $-55^{\circ}\text{C}$  to  $+125^{\circ}\text{C}$ . The  $\mu A711$  is specified over the commercial/industrial temperature range of  $0^{\circ}\text{C}$  to  $+75^{\circ}\text{C}$ .

### FEATURES

- FAST RESPONSE – 40ns
- HIGH SENSITIVITY – 1.5V/mV
- LOW OFFSET VOLTAGE TEMPERATURE COEFFICIENT –  $5\mu\text{V}/^{\circ}\text{C}$
- HIGH INPUT VOLTAGE RANGE –  $\pm 5.0\text{V}$

### ABSOLUTE MAXIMUM RATINGS

Positive Supply Voltage	+14.0V
Negative Supply Voltage	-7.0V
Peak Output Current	50mA
Differential Input Voltage	$\pm 5.0\text{V}$
Input Voltage	$\pm 7.0\text{V}$
Internal Power Dissipation (Note 4) TO-99	300mW
Operating Temperature Range	
$\mu A711$	$-55^{\circ}\text{C}$ to $+125^{\circ}\text{C}$
$\mu A711\text{C}$	$0^{\circ}\text{C}$ to $+75^{\circ}\text{C}$
Storage Temperature Range	$-65^{\circ}\text{C}$ to $+150^{\circ}\text{C}$
Lead Temperature (Soldering, 60 sec)	$300^{\circ}\text{C}$

Maximum ratings are limiting values above which serviceability may be impaired.

### PIN CONFIGURATION

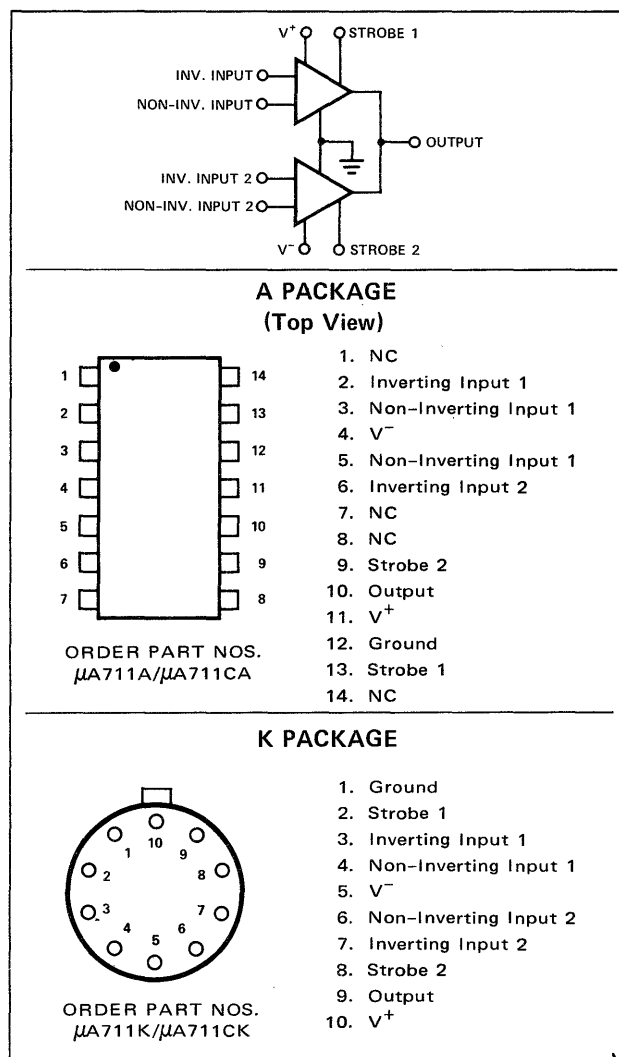

### BASIC CIRCUIT SCHEMATIC

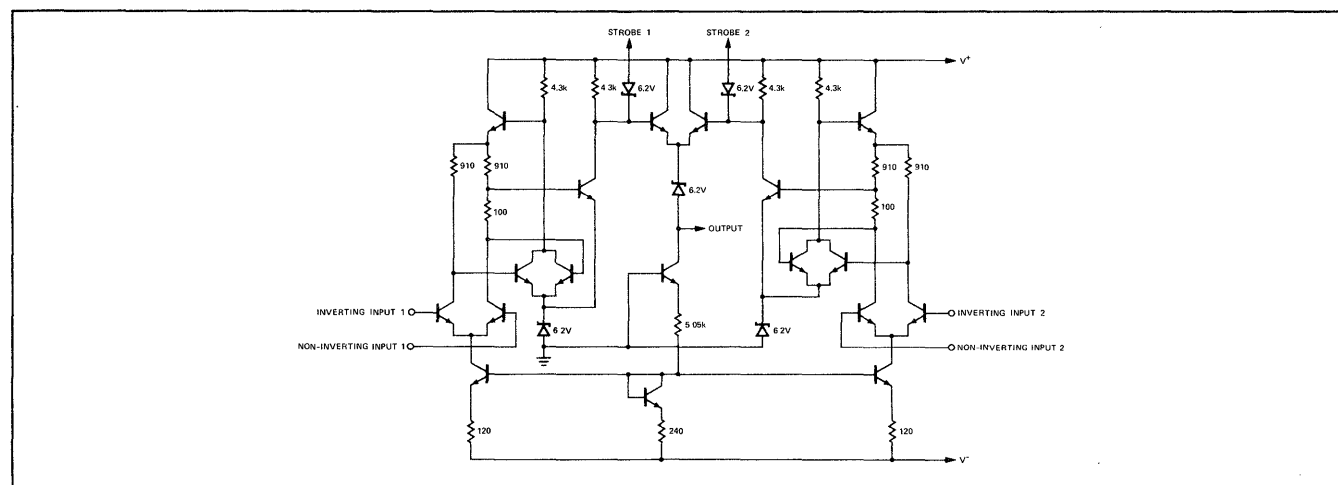



# SIGNETICS ■ $\mu$ A711 – DUAL VOLTAGE COMPARATOR

## ELECTRICAL CHARACTERISTICS (Note 1)

(Standard Conditions:  $T_A = +25^\circ\text{C}$ ,  $V^+ = 12.0\text{V}$ ,  $V^- = -6.0\text{V}$  unless otherwise specified)

PARAMETERS	TEST CONDITIONS	MIN		TYP		MAX		UNITS
		$\mu$ A711	711C	$\mu$ A711	711C	$\mu$ A711	711C	
Input Offset Voltage	$V_{out} = +1.4\text{V}$ , $R_S \leq 200\Omega$ , $V_{cm} = 0$			1.0	1.0	3.5	5.0	mV
	$V_{out} = +1.4\text{V}$ , $R_S \leq 200\Omega$			1.0	1.0	5.0	7.5	mV
Input Offset Current	$V_{out} = +1.4\text{V}$			0.5	0.5	10.0	15.0	$\mu\text{A}$
Input Bias Current				25	25	75	100	$\mu\text{A}$
Voltage Gain		750	700	1500	1500			
Response Time	Note 2			40	40			ns
Strobe Release Time				12	12			ns
Input Common Mode Voltage Range	$V^- = -7.0\text{V}$	$\pm 5.0$	$\pm 5.0$					V
Differential Input Voltage Range		$\pm 5.0$	$\pm 5.0$					V
Output Resistance				200	200			$\Omega$
Positive Output Level	$V_{in} \geq 10\text{mV}$			4.5	4.5	5.0	5.0	V
Loaded Positive Output Level	$V_{in} \geq 10\text{mV}$ , $I_o = 5\text{mA}$	2.5	2.5	3.5	3.5			V
Negative Output Level	$V_{in} \geq 10\text{mV}$	-1.0	-1.0	-0.5	-0.5	0	0	V
Strobed Output Level	$V_{strobe} < 0.3\text{V}$	-1.0	-1.0			0	0	V
Output Sink Current	$V_{in} \geq 10\text{mV}$ , $V_{out} \geq 0$	0.5	0.5	0.8	0.8			mA
Strobe Current	$V_{strobe} = 100\text{mV}$			1.2	1.2	2.5	2.5	mA
Positive Supply Current	$V_{out} \leq 0$			8.6	8.6			mA
Negative Supply Current				3.9	3.9			mA
Power Consumption				130	130	200	200	mW

The following specifications apply over the temperature ranges of:  $-55^\circ\text{C} \leq T_A \leq +125^\circ\text{C}$  for the  $\mu$ A711  
 $0^\circ\text{C} \leq T_A \leq +75^\circ\text{C}$  for the  $\mu$ A711C

Input Offset Voltage	$R_S \leq 200\Omega$ , $V_{cm} = 0$ , $R_S \leq 200\Omega$	Note 3				4.5	6.0	mV
						6.0	10.0	mV
Input Offset Current		Note 3				20	25	$\mu\text{A}$
Input Bias Current						150	150	$\mu\text{A}$
Temperature Coefficient of Input Offset Voltage				5.0	5.0			$\mu\text{V}/^\circ\text{C}$
Voltage Gain			500	500				

Recommended Operating Supply Voltages:  $V^+ = 12\text{V}$ ,  $V^- = -6\text{V}$

### NOTES:

- All voltages are referenced to pin 1.
- The response time specified is for a 100mV input step, with a 5mV overdrive.
- The Input Offset Voltage and Input Offset Current are specified for a logic threshold voltage of: 1.8V at  $0^\circ\text{C}$ .

$\mu$ A711	$\mu$ A711C
1.8V at $0^\circ\text{C}$	1.5V at $0^\circ\text{C}$
1.4V at $+25^\circ\text{C}$	1.4V at $+25^\circ\text{C}$
1.0V at $+125^\circ\text{C}$	1.2V at $+75^\circ\text{C}$
- Rating applies for temperatures up to:  $\mu$ A711 –  $+125^\circ\text{C}$   
 $\mu$ A711C –  $+75^\circ\text{C}$

## LINEAR INTEGRATED CIRCUITS

### DESCRIPTION

The NE528B is a monolithic four channel plated wire sense amplifier designed to read small signals, 3mV or above, and translate them to TTL logic levels. The NE528B features input channel selection by means of three TTL channel select inputs, one of which allows for total input disable. The output is TTL compatible and can be used in the "WIRED-OR" configuration.

### FEATURES

- FOUR CHANNELS IN ONE PACKAGE
- TOTAL INPUT DISABLE PROVIDED
- 16mA SINK CAPABILITY
- OUTPUT STRUCTURE ALLOWS FOR WIRED-OR, PARALLELING
- CHANNEL SELECT, STROBE AND OUTPUT TTL COMPATIBLE

### ABSOLUTE MAXIMUM RATINGS

Supply Voltage	±10V
Strobe Control Voltage	+6V
Differential Input Voltage	±5V
Amplifier Input Current	2mA
Common Mode Input Voltage	+5 to -6V
Storage Temperature Range	-65°C to +150°C
Operating Temperature Range	0°C to 70°C

### PIN CONFIGURATION

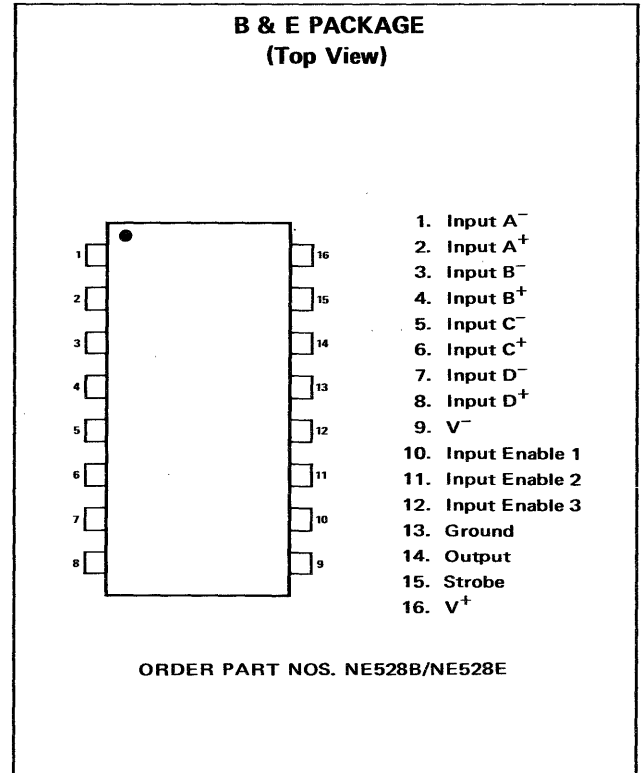

### LOGIC DIAGRAM AND TRUTH TABLE

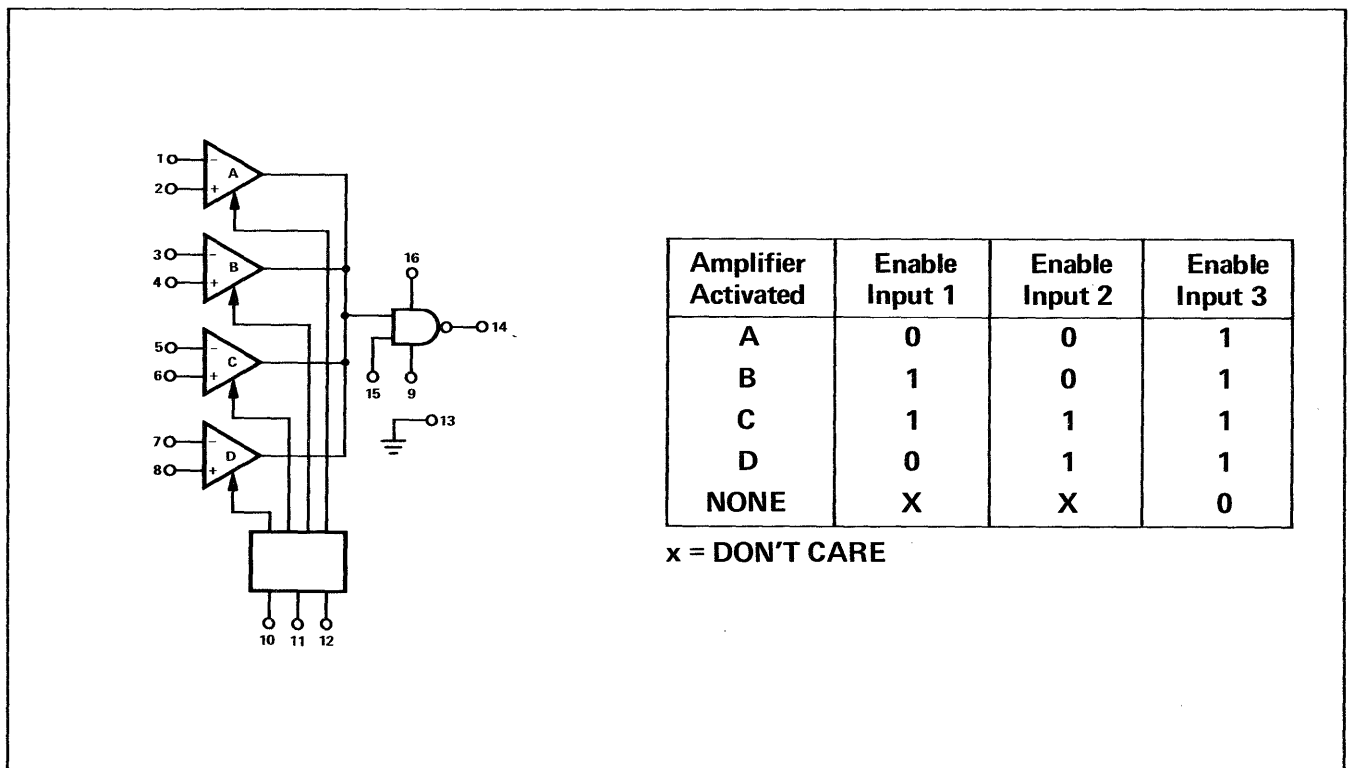

**SIGNETICS ■ 528 – FOUR CHANNEL PLATED WIRE MEMORY SENSE AMPLIFIER**

**ELECTRICAL CHARACTERISTICS** (Conditions:  $V^+ = 5V$ ,  $V^- = -6V$ ,  $T_A = 25^\circ$  unless specified)

PARAMETERS	TEST CONDITIONS	MIN	TYP	MAX	UNITS
Input Bias Current	$V^+ = 5.25V$ , $V^- = -6.3V$ , $V_{in} = 0$		15	50	$\mu A$
Input Offset Current	$V^+ = 5.25V$ , $V^- = -6.3V$ , $V_{in} = 0$		0.5	5	$\mu A$
Differential Input Threshold Voltage	Figure 1	-3		+3	mV
Output Voltage					
"1" State	$V^+ = 4.75V$	2.4			V
"0" State	$V^+ = 5.25V$			0.4	V
Enable and Strobe Inputs					
"0" Input Current	$V^+ = 5.25V$ , $V^- = -6.3V$ , $V_{in} = 0.4V$			-1.6	mA
"1" Input Current	$V^+ = 5.25V$ , $V^- = -6.3V$ , $V_{in} = 2.4V$			40	$\mu A$
"0" Input Voltage	$V^+ = 4.75V$ , $V^- = -5.7V$			0.8	V
"1" Input Voltage	$V^+ = 4.75V$ , $V^- = -5.7V$	2.0			V
Power Consumption	$V^+ = 5.25V$ , $V^- = -6.3V$			270	mW
Positive Supply Current	$V^+ = 5.25V$ , $V^- = -6.3V$			35	mA
Negative Supply Current	$V^+ = 5.25V$ , $V^- = -6.3V$			15	mA
Input Resistance	$f = 1$ kHz		2K		$\Omega$
Propagation Delay	Unused Inputs Grounded, Figure 2				
$t_{pd}(0)$			20		nsec
$t_{pd}(1)$			25		nsec
Output Rise Time	Figure 3		16		nsec
Output Fall Time	Figure 3		6		nsec
Strobe Delay Time	Figure 2				
Turn On			10		nsec
Turn Off			12		nsec
Channel Select Time	Figure 3		9		nsec
Total Disable to Enable Time	Figure 2		25		nsec
Enable to Total Disable Time	Figure 2		28		nsec

**LOGIC DIAGRAM AND TEST TABLE** ( $V^+ = 5V$ ,  $V^- = -6V$ ,  $T_A = 25^\circ C$ )

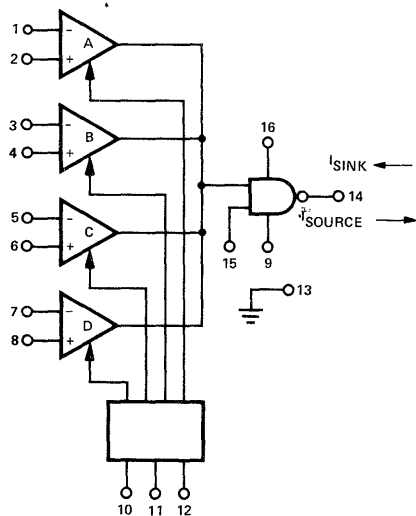

Pin 10	Pin 11	Pin 12	Pin 15	Enabled Inputs	$V_{in}$	$V_{out}$	$I_{sink}$	$I_{source}$
0	0	1	1	1-2	3mV	$\leq 0.4V$	16mA	
0	0	1	1	1-2	-3mV	$\geq 2.4V$		-400 $\mu A$
0	0	1	1	2-1	3mV	$\geq 2.4V$		-400 $\mu A$
0	0	1	1	2-1	-3mV	$\leq 0.4V$	16mA	
1	0	1	1	3-4	3mV	$\leq 0.4V$	16mA	
1	0	1	1	3-4	-3mV	$\geq 2.4V$		-400 $\mu A$
1	0	1	1	4-3	3mV	$\geq 2.4V$		-400 $\mu A$
1	0	1	1	4-3	-3mV	$\leq 0.4V$	16mA	
1	1	1	1	5-6	3mV	$\leq 0.4V$	16mA	
1	1	1	1	5-6	-3mV	$\geq 2.4V$		-400 $\mu A$
1	1	1	1	6-5	3mV	$\geq 2.4V$		-400 $\mu A$
1	1	1	1	6-5	-3mV	$\leq 0.4V$	16mA	
0	1	1	1	7-8	3mV	$\leq 0.4V$	16mA	
0	1	1	1	7-8	-3mV	$\geq 2.4V$		-400 $\mu A$
0	1	1	1	8-7	3mV	$\geq 2.4V$		-400 $\mu A$
0	1	1	1	8-7	-3mV	$\leq 0.4V$	16mA	
X	X	X	0	X	X	$\geq 2.4V$		-400 $\mu A$
X	X	0	X	X	X	$\geq 2.4V$		-400 $\mu A$

FIGURE 1

TEST FIGURE AND WAVEFORMS

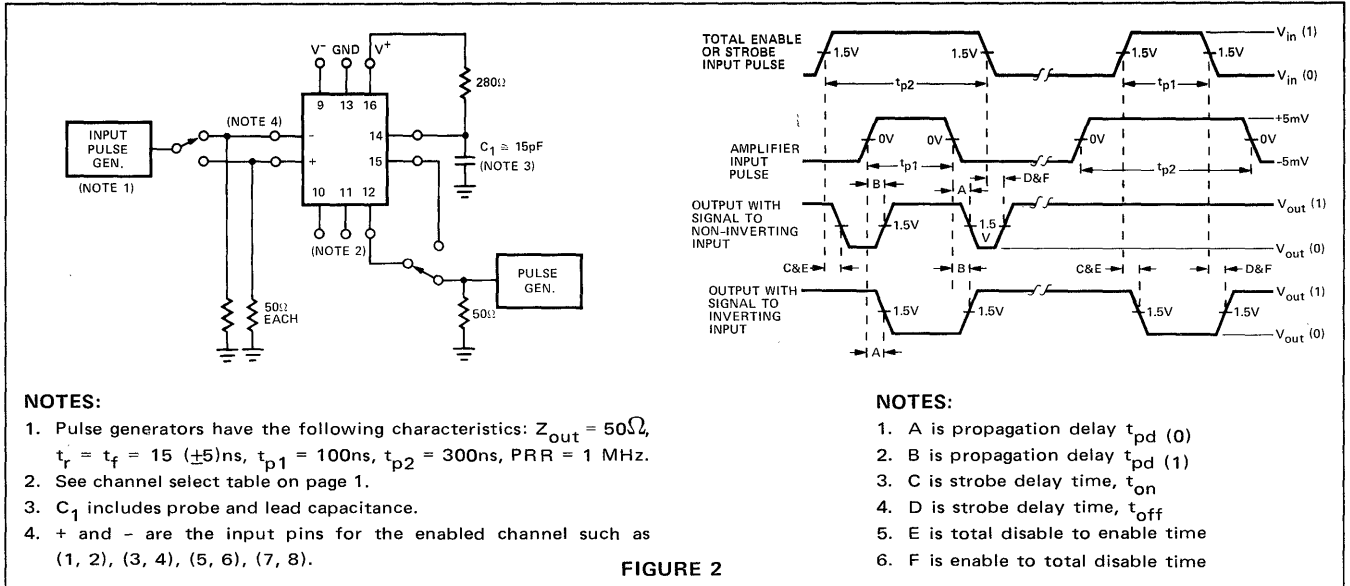

FIGURE 2

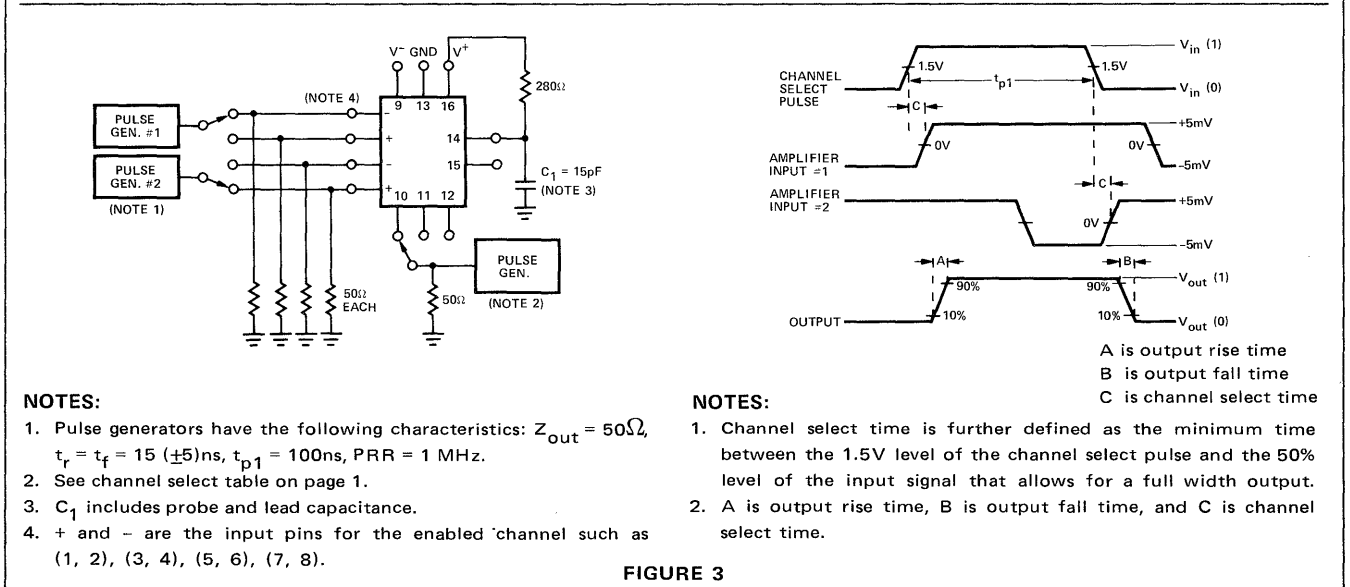
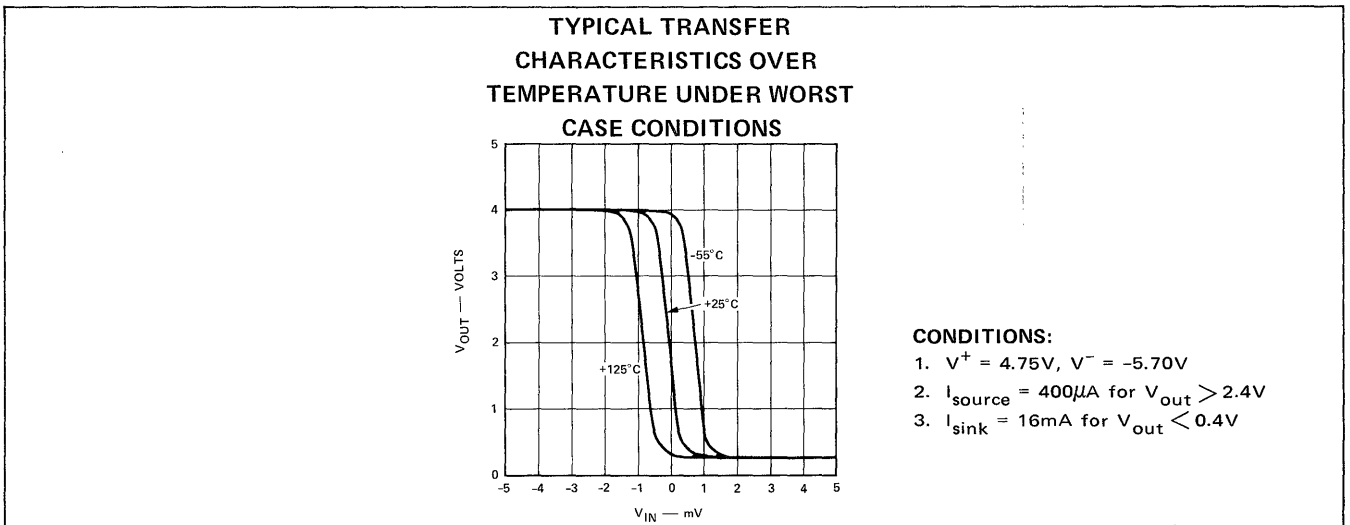
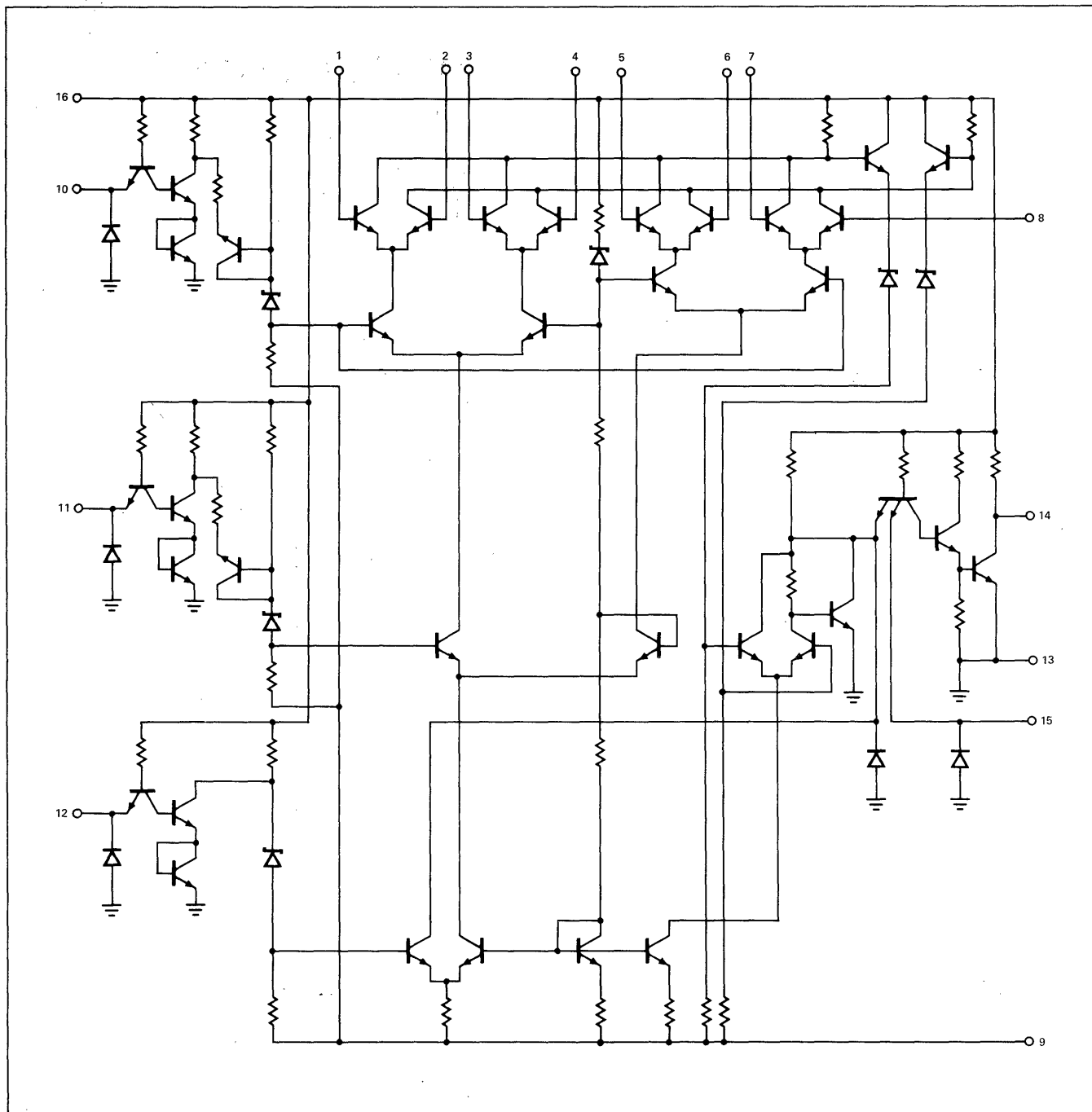

FIGURE 3

TYPICAL CHARACTERISTIC CURVE



EQUIVALENT SCHEMATIC DIAGRAM



# Signetics DUAL CORE SENSE MEMORY AMPLIFIERS

SN7520  
SN7521  
SN7522  
SN7523  
SN7524  
SN7525

## LINEAR INTEGRATED CIRCUITS

### DESCRIPTION

The 7520 Series Dual Core Memory Sense Amplifiers are designed for use in high speed core memory systems. Three separate logic configurations allow flexibility of system design.

The 7520 and 7521 can be used to perform the function of a flip-flop or a data register which responds to the sense and strobe-input conditions.

The 7522 and 7523 features an open collector stage which may be used to perform the wired-OR function.

The 7524 and 7525 features two independent sense channels with separate outputs.

### FEATURES

- DUAL SENSE AMPS
- $\pm 4\text{mV}$  THRESHOLD UNCERTAINTY
- DESIGN VERSATILITY
- 25ns PROPAGATION DELAY

### ABSOLUTE MAXIMUM RATINGS

Differential Input Voltage	$\pm 5\text{V}$
$V_{CC}$	$\pm 7\text{V}$
Strobe & Gain Input Voltages	+5.5V
Storage Temperature	$-65^{\circ}\text{C}$ to $+150^{\circ}\text{C}$
Operating Temperature	$0^{\circ}\text{C}$ to $+70^{\circ}\text{C}$
Power Dissipation	500mW

### PIN CONFIGURATIONS

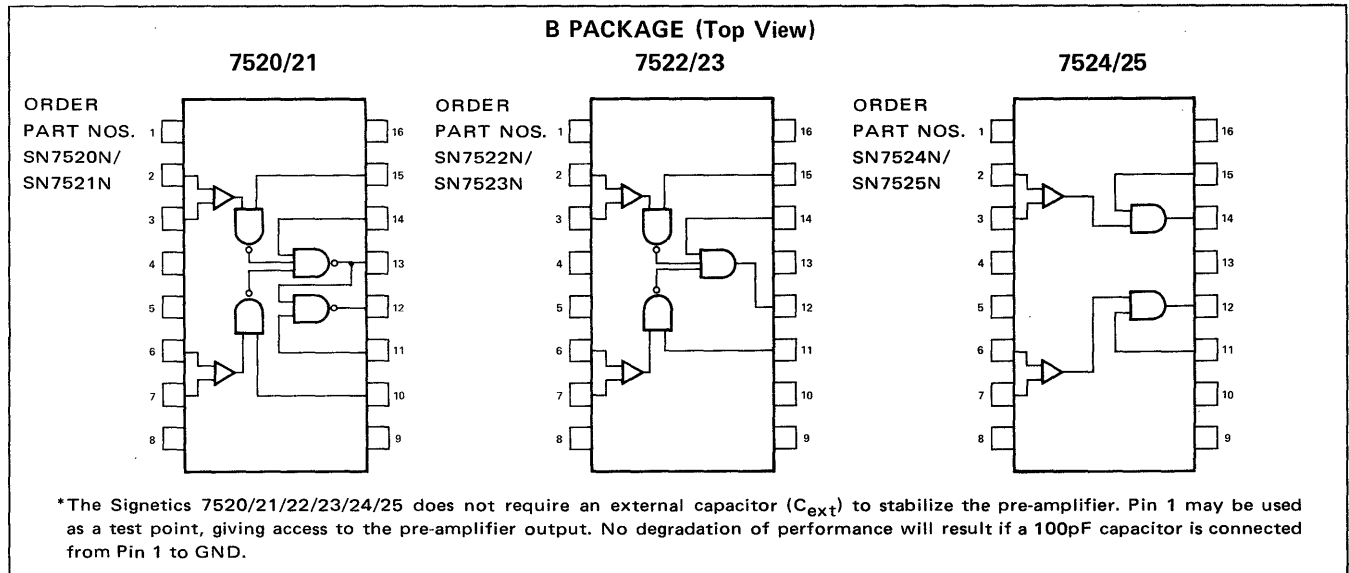

### LOGIC DIAGRAMS

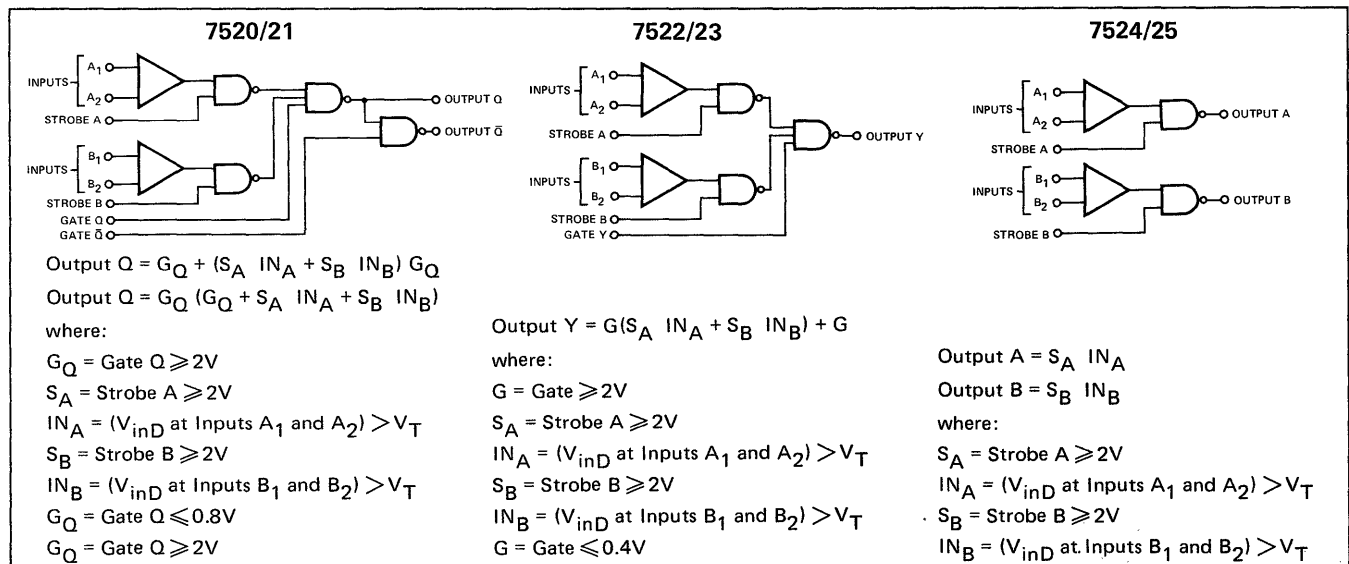

**SIGNETICS ■ 7520/7521 – DUAL CORE MEMORY SENSE AMPLIFIERS**

**ELECTRICAL CHARACTERISTICS** ( $V_{cc1} = 5V, V_{cc2} = -5V, T_A = 0^\circ C$  to  $+70^\circ C$ , unless otherwise specified)

PARAMETER		TEST CONDITIONS	MIN	TYP	MAX	UNITS	
$V_T$	Differential-Input Threshold Voltage (See Note 1)	$V_{ref} = 15mV$	7520	11	15	18	mV
			7521	8	15	22	mV
		$V_{ref} = 40mV$	7520	36	40	44	mV
			7521	33	40	47	mV
$V_{CMF}$	Common-Mode Input Firing Voltage (See Note 2)	Strobe Input: $V_{inS} = V_{in(1)}$ Common-Mode Input Pulse: $t_r = t_f \leq 15ns, t_{p(in)} = 50ns$ $T_A = 25^\circ C$		$\pm 3$		V	
$I_{in}$	Differential-Input Bias Current	$V_{cc1} = 5.25V, V_{cc2} = -5.25V$ $V_{inD} = 0mV$		30	75	$\mu A$	
$I_{DI}$	Differential-Input Offset Current	$V_{cc1} = 5.25V, V_{cc2} = -5.25V$		0.5		$\mu A$	
$Z_{inD}$	Differential-Input Impedance	$f = 1 kHz$		2		$k\Omega$	
$V_{in(1)}$	Logical 1 Input Voltage (gate and strobe inputs)	$V_{cc1} = 4.75V, V_{cc2} = -4.75V$ $V_{in(0)} = 0.8V$	2			V	
$V_{in(0)}$	Logical 0 Input Voltage (gate and strobe inputs)	$V_{cc1} = 4.75V, V_{cc2} = -4.75V$ $V_{in(1)} = 2V$			0.8	V	
$I_{in(0)}$	Logical 0 Level Input Current (gate and strobe inputs)	$V_{cc1} = 5.25V, V_{cc2} = -5.25V$ $V_{in(0)} = 0.4V$			-1.6	mA	
$I_{in(1)}$	Logical 1 Level Input Current (gate and strobe inputs)	$V_{cc1} = 5.25V, V_{cc2} = -5.25V$ $V_{in(1)} = 2.4V$			40	$\mu A$	
		$V_{cc1} = 5.25V, V_{cc2} = -5.25V$ $V_{in(1)} = V_{cc1}$			1	mA	
$V_{out(1)}$	Logical 1 Output Voltage	$V_{cc1} = 4.75V, V_{cc2} = -4.75V$ $I_{load} = -400\mu A$	2.4	3.9		V	
$V_{out(0)}$	Logical 0 Output Voltage	$V_{cc1} = 4.75V, V_{cc2} = -4.75V$ $I_{sink} = 16mA$		0.25	0.4	V	
$I_{OS(Q)}$	Q Output Short-Circuit Current	$V_{cc1} = 5.25V, V_{cc2} = -5.25V$	3.3		5	mA	
$I_{OS(Q)}$	Q Output Short-Circuit Current	$V_{cc1} = 5.25V, V_{cc2} = -5.25V$	2.1		3.5	mA	
$I_{cc1}$	$V_{cc1}$ Supply Current	$T_A = 25^\circ C$		28		mA	
$I_{cc2}$	$V_{cc2}$ Supply Current	$T_A = 25^\circ C$		-14		mA	
$t_{or D}$	Differential-Input Overload Recovery Time (See Note 3)	$V_{inD} = 2V, t_r = t_f = 20ns$		20		ns	
$t_{or CM}$	Common-Mode Input Overload Recovery Time (See Note 4)	$V_{inCM} = 2V, t_r = t_f = 20ns$		20		ns	
$t_{cyc(min)}$	Minimum cycle time			200		ns	

PROPAGATION DELAY TIMES			MIN	TYP	MAX	UNIT
SYMBOL	FROM INPUT	TO OUTPUT				
$t_{pd(1)DQ}, t_{pd(0)DQ}$	$A_1 - A_2$ or $B_1 - B_2$	Q		20 30	40	ns ns
$t_{pd(1)D\bar{Q}}, t_{pd(0)D\bar{Q}}$	$A_1 - A_2$ or $B_1 - B_2$	$\bar{Q}$		25 35	55	ns ns
$t_{pd(1)SQ}, t_{pd(0)SQ}$	Strobe A or B	Q		15 25	30	ns ns
$t_{pd(1)S\bar{Q}}, t_{pd(0)S\bar{Q}}$	Strobe A or B	$\bar{Q}$		15 35	55	ns ns
$t_{pd(1)G_Q}, t_{pd(0)G_Q}$	Gate Q	Q		10 15	20	ns ns
$t_{pd(1)G_{\bar{Q}}}, t_{pd(0)G_{\bar{Q}}}$	Gate $\bar{Q}$	$\bar{Q}$		15 20	30	ns ns
$t_{pd(1)G_{\bar{Q}}}, t_{pd(0)G_{\bar{Q}}}$	Gate $\bar{Q}$	$\bar{Q}$		15 10	20	ns ns

(SEE NOTES PAGE 128)

**SIGNETICS ■ 7522/7523 – DUAL CORE MEMORY SENSE AMPLIFIERS**

**ELECTRICAL CHARACTERISTICS** ( $V_{cc1} = 5V$ ,  $V_{cc2} = -5V$ ,  $T_A = 0^\circ C$  to  $+70^\circ C$ , unless otherwise noted)

PARAMETER		TEST CONDITIONS		MIN	TYP	MAX	UNIT
$V_T$	Differential Input Threshold Voltage (See Note 1)	$V_{ref} = 15mV$	7522	11	15	19	mV
			7523	8	15	22	mV
		$V_{ref} = 40mV$	7522	36	40	44	mV
			7523	33	40	47	mV
$V_{CMF}$	Common Mode Input Firing Voltage (See Note 2)	Strobe Input: $V_{inS} = V_{in(1)}$ Common Mode Input Pulse: $t_r = t_f \geq 15ns$ , $t_{p(in)} = 50ns$ $T_A = 25^\circ C$			$\pm 3$		V
$I_{in}$	Differential Input Bias Current	$V_{cc1} = 5.25V$ , $V_{cc2} = -5.25V$ $V_{inD} = 0mV$			30	75	$\mu A$
$I_{D1}$	Differential Input Offset Current	$V_{cc1} = 5.25V$ , $V_{cc2} = -5.25V$ $f = 1 kHz$			0.5		$\mu A$
$Z_{inD}$	Differential Input Impedance				2		$k\Omega$
$V_{in(1)}$	Logical 1 Input Voltage (gate and strobe inputs)	$V_{cc1} = 4.75V$ , $V_{cc2} = -4.75V$ $V_{in(0)} = 0.8V$		2			V
$V_{in(0)}$	Logical 0 Input Voltage (gate and strobe inputs)	$V_{cc1} = 4.75V$ , $V_{cc2} = -4.75V$ $V_{in(1)} = 2V$				0.8	V
$I_{in(0)}$	Logical 0 Level Input Current (gate and strobe inputs)	$V_{cc1} = 5.25V$ , $V_{cc2} = -5.25V$ $V_{in(0)} = 0.4V$			-1	-1.6	$mA$
$I_{in(1)}$	Logical 1 Level Input Current (gate and strobe inputs)	$V_{cc1} = 5.25V$ , $V_{cc2} = -5.25V$ $V_{in(1)} = 2.4V$				40	$\mu A$
		$V_{cc1} = 5.25V$ , $V_{cc2} = -5.25V$ $V_{in(1)} = V_{cc1}$				1	$mA$
$V_{out(1)}$	Logical 1 Output Voltage	$V_{cc1} = 4.75V$ , $V_{cc2} = -4.75V$ $I_{load} = -400\mu A$ , $V_{in} = 2V$		2.4	3.9		V
$V_{out(0)}$	Logical 0 Output Voltage	$V_{cc1} = 4.75V$ , $V_{cc2} = -4.75V$ $I_{sink} = 16mA$ , $V_{in} = 0.8V$			0.2	0.4	V
$I_{out(1)}$	Output Reverse Current	$V_{cc1} = 4.75V$ , $V_{cc2} = -4.75V$ $V_{out} = 5.25V$ , $V_{in} = 2V$				250	$\mu A$
$I_{OS}$	Output Short Circuit Current	$V_{cc1} = 5.25V$ , $V_{cc2} = -5.25V$		2.1		3.5	$mA$
$I_{cc1}$	$V_{cc1}$ Supply Current	$T_A = 25^\circ C$			27		$mA$
$I_{cc2}$	$V_{cc2}$ Supply Current	$T_A = 25^\circ C$			15		$mA$
$t_{orD}$	Differential Input Overload Recovery Time (See Note 3)	$V_{inD} = 2V$ , $t_r = t_f = 20ns$			20		ns
$t_{orCM}$	Common Mode Input Overload Recovery Time (See Note 4)	$V_{inCM} = \pm 2V$ , $t_r = t_f = 20ns$			20		ns
$t_{cyc(min)}$	Minimum Cycle Time				200		ns

PROPAGATION DELAY TIMES			MIN	TYP	MAX	UNIT
SYMBOL	FROM INPUT	TO OUTPUT				
$t_{pd(1)D}$	A <sub>1</sub> - A <sub>2</sub> or B <sub>1</sub> - B <sub>2</sub>	Y		20		ns
$t_{pd(0)D}$				30	45	ns
$t_{pd(1)S}$	Strobe A or B	Y		15		ns
$t_{pd(0)S}$				25	40	ns
$t_{pd(1)G}$	Gate	Y		10		ns
$t_{pd(0)G}$				15	25	ns

(SEE NOTES PAGE 128)



**SIGNETICS ■ 7524/7525 – DUAL CORE MEMORY SENSE AMPLIFIERS**

**ELECTRICAL CHARACTERISTICS** ( $V_{cc1} = 5V, V_{cc2} = -5V, T_A = 0^\circ C$  to  $+70^\circ C$ , unless otherwise specified)

PARAMETER		TEST CONDITIONS	MIN	TYP	MAX	UNIT
$V_T$	Differential Input Threshold Voltage (See Note 1)	$V_{ref} = 15mV$ 7524	11	15	19	mV
		7525	8	15	22	mV
		$V_{ref} = 40mV$ 7524	36	40	44	mV
		7525	33	40	47	mV
$V_{CMF}$	Common Mode Input Firing Voltage (See Note 2)	Strobe Input: $V_{inS} = V_{in(1)}$ Common Mode Input Pulse: $t_r = t_f \leq 15ns, t_{p(in)} = 50ns$ $T_A = 25^\circ C$		$\pm 3$		V
$I_{in}$	Differential Input Bias Current	$V_{cc1} = 5.25V, V_{cc2} = -5.25V$ $V_{inD} = 0mV$		30	75	$\mu A$
$I_{DI}$	Differential Input Offset Current	$V_{cc1} = 5.25V, V_{cc2} = -5.25V$		0.5		$\mu A$
$Z_{inD}$	Differential Input Impedance	$f = 1\text{ kHz}$		2		$k\Omega$
$V_{in(1)}$	Logical 1 Input Voltage (strobe inputs)	$V_{cc1} = 4.75V, V_{cc2} = -4.75V$ $V_{in(0)} = 0.8V$	2			V
$V_{in(0)}$	Logical 0 Input Voltage (strobe inputs)	$V_{cc1} = 4.75V, V_{cc2} = -4.75V$ $V_{in(1)} = 2V$			0.8	V
$I_{in(0)}$	Logical 0 Level Input Current (strobe inputs)	$V_{cc1} = 5.25V, V_{cc2} = -5.25V$ $V_{in(0)} = 0.4V$		-1	-1.6	mA
$I_{in(1)}$	Logical 1 Level Input Current (strobe inputs)	$V_{cc1} = 5.25V, V_{cc2} = -5.25V$ $V_{in(1)} = 2.4V$			40	$\mu A$
		$V_{cc1} = 5.25V, V_{cc2} = -5.25V$ $V_{in(1)} = V_{cc1}$			1	mA
$V_{out(1)}$	Logical 1 Output Voltage	$V_{cc1} = 4.75V, V_{cc2} = -4.75V$ $I_{load} = -400\mu A, V_{in(1)} = 2V$ $V_{in(0)} = 0.8V$	2.4	3.9		V
$V_{out(0)}$	Logical 0 Output Voltage	$V_{cc1} = 4.75V, V_{cc2} = -4.75V$ $I_{sink} = 16mA, V_{in(0)} = 0.8V$		0.25	0.4	V
$I_{OS}$	Output Short Circuit Current	$V_{cc1} = 5.25V, V_{cc2} = -5.25V$	2.1		3.5	mA
$I_{cc1}$	$V_{cc1}$ Supply Current	$T_A = 25^\circ C$		25		mA
$I_{cc2}$	$V_{cc2}$ Supply Current	$T_A = 25^\circ C$		-15		mA
$t_{orD}$	Differential Input Overload Recovery Time (See Note 3)	$V_{inD} = 2V, t_r = t_f = 20ns$		20		ns
$t_{orCM}$	Common Mode Input Overload Recovery Time (See Note 4)	$V_{inCM} = \pm 2V, t_r = t_f = 20ns$		20		ns
$t_{cyc(min)}$	Minimum Cycle Time			200		ns

PROPAGATION DELAY TIMES			MIN	TYP	MAX	UNIT
SYMBOL	FROM INPUT	TO OUTPUT				
$t_{pd(1)D}$	$A_1 - A_2$ or $B_1 - B_2$	A or B		25	40	ns
$t_{pd(0)D}$				20		ns
$t_{pd(1)S}$	Strobe A or B	A or B		15	30	ns
$t_{pd(0)S}$				20		ns

**NOTES:**

- The differential input threshold voltage ( $V_T$ ) is defined as the DC input voltage ( $V_{in}$ ) required to force the output of the sense amplifier to the logic gate threshold voltage level.
- Common mode input firing voltage is the common mode voltage that will exceed the dynamic range of the input at the specified conditions and cause the logic output to switch. The specified common mode input signal is applied with a strobe enable signal present.
- Differential input overload recovery time is the time necessary for the device to recover from the specified differential input overload signal prior to the strobe enable signal.
- Common mode input overload recovery time is the time necessary for the device to recover from the specified common mode input overload signal prior to the strobe enable signal.

SCHEMATIC DIAGRAMS

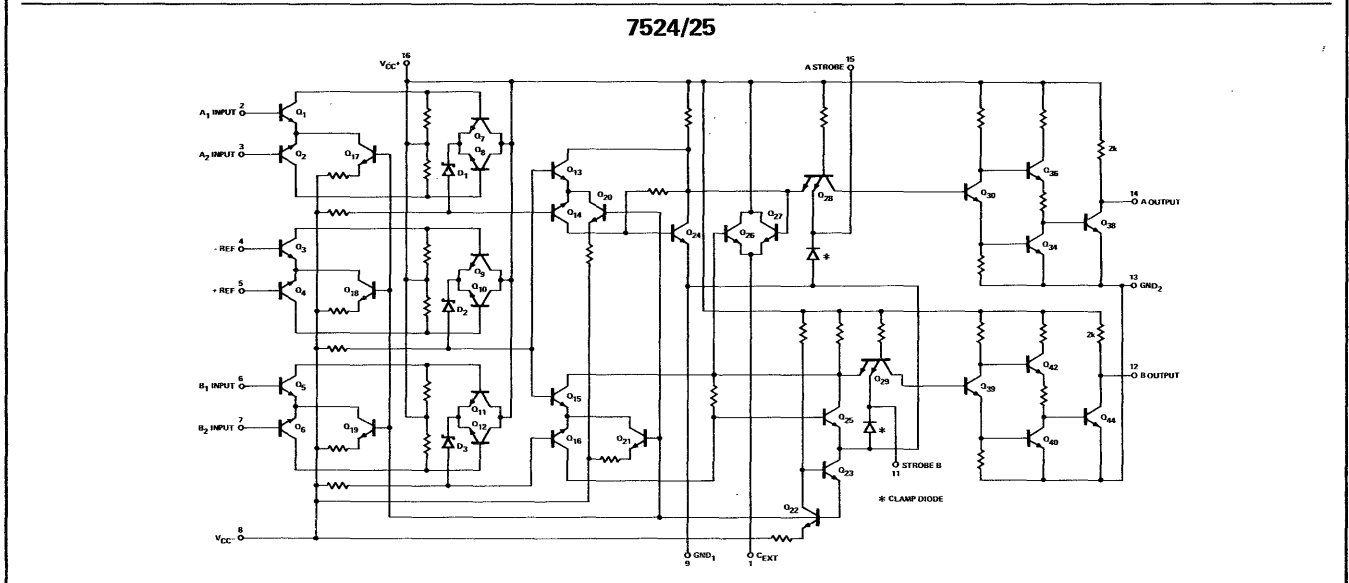
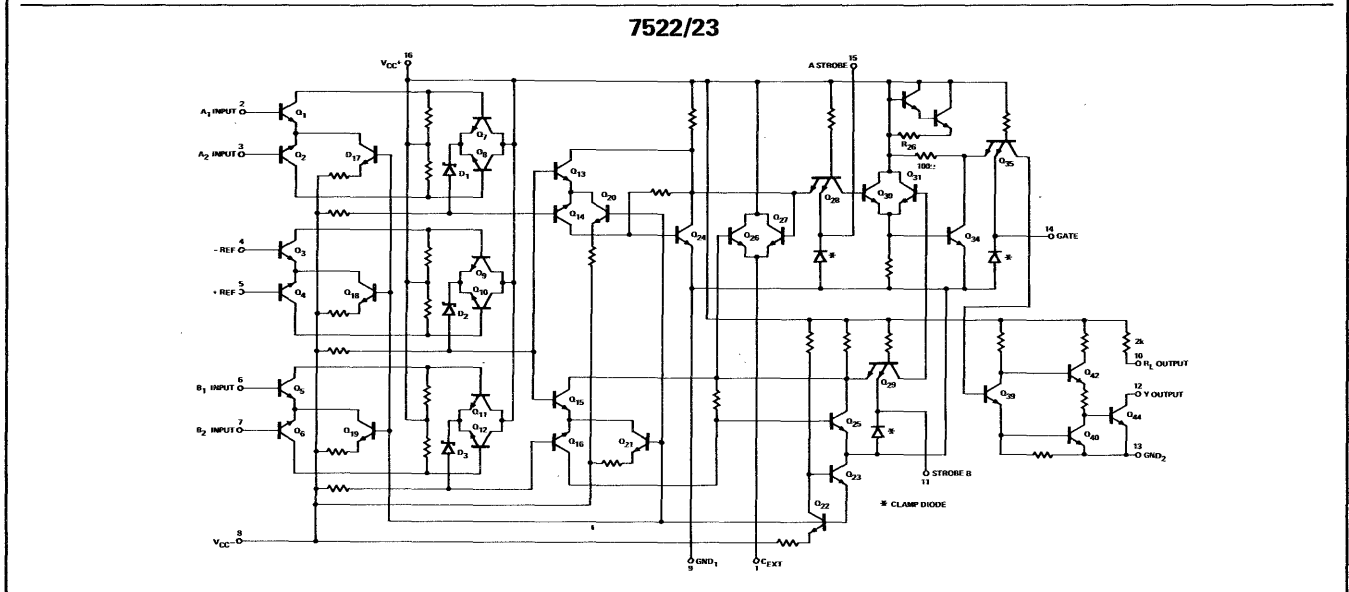
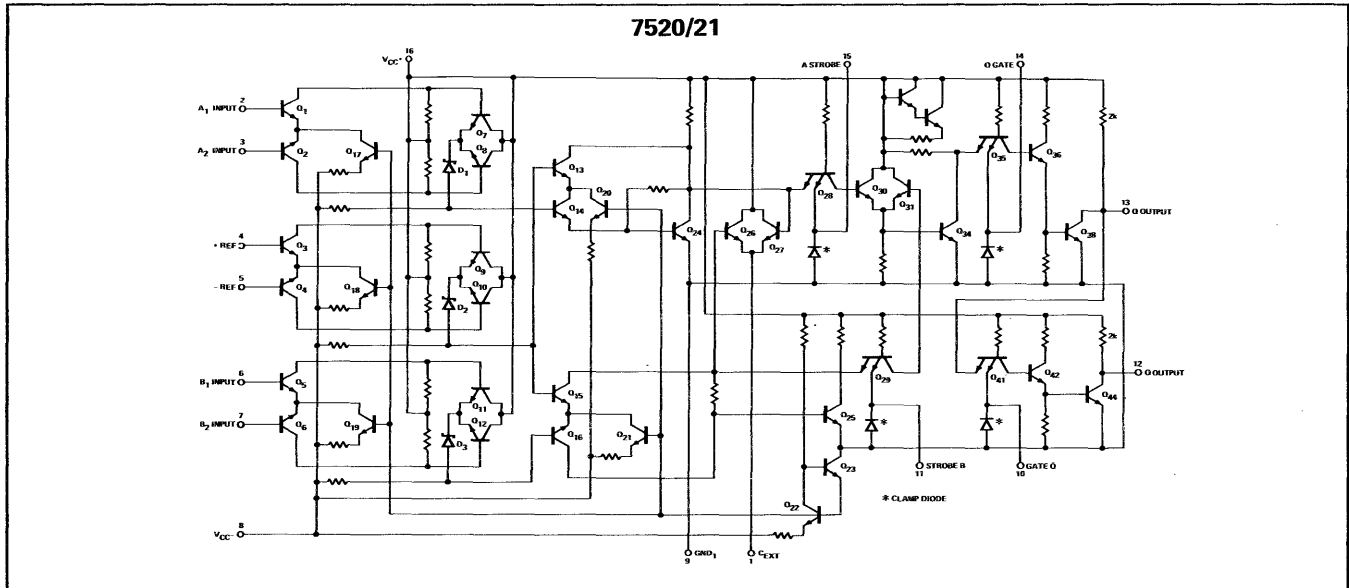

TYPICAL CHARACTERISTIC CURVES

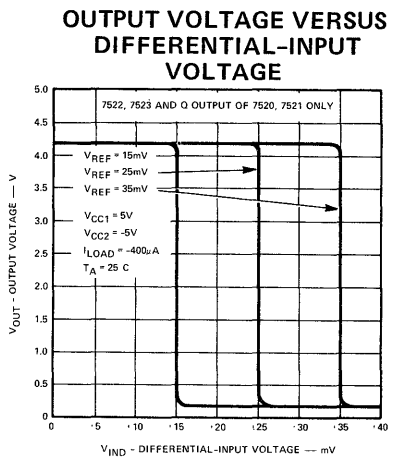
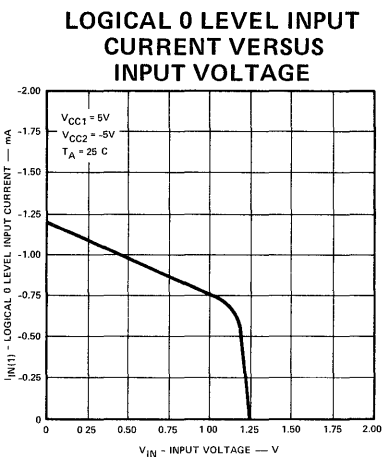
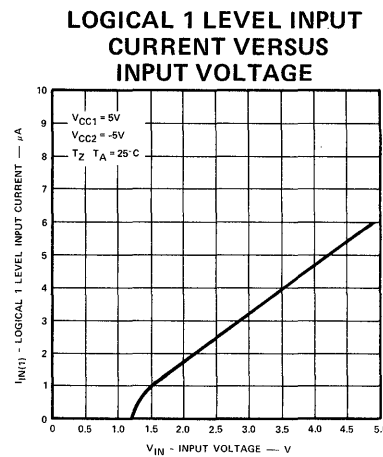
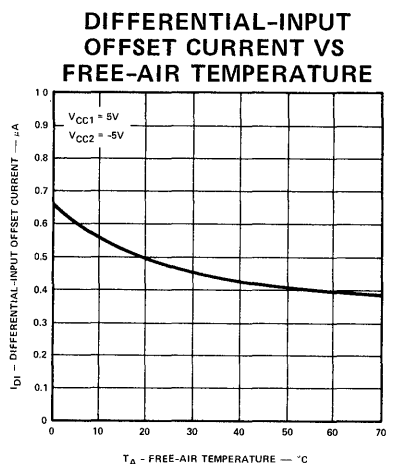
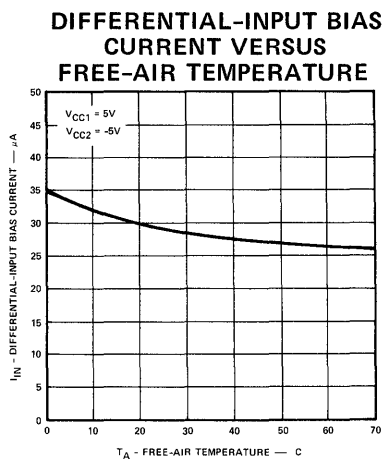
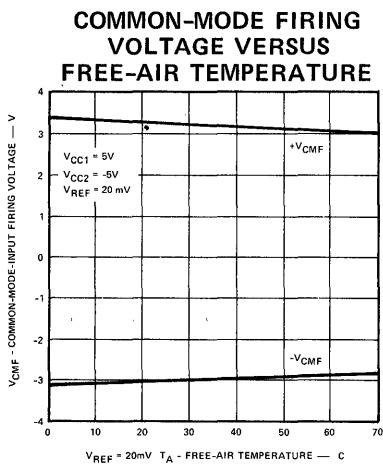
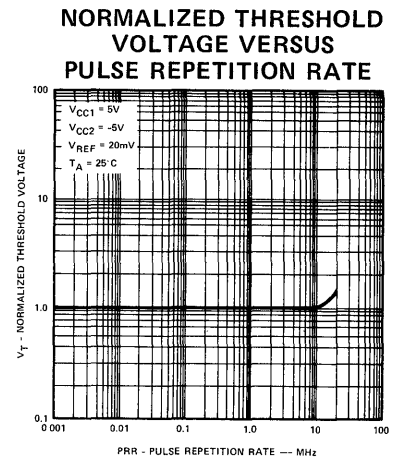
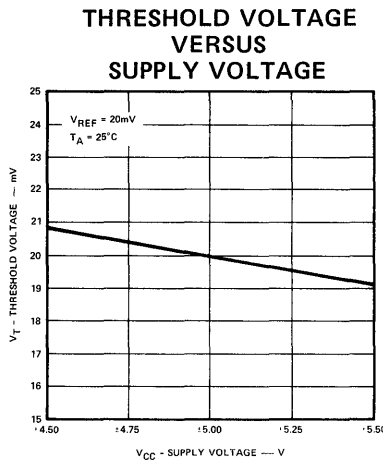
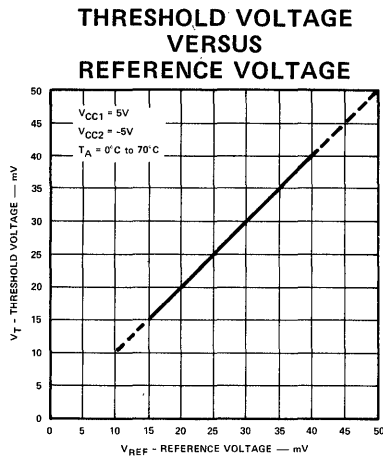

TYPICAL CHARACTERISTIC CURVES (Cont'd.)

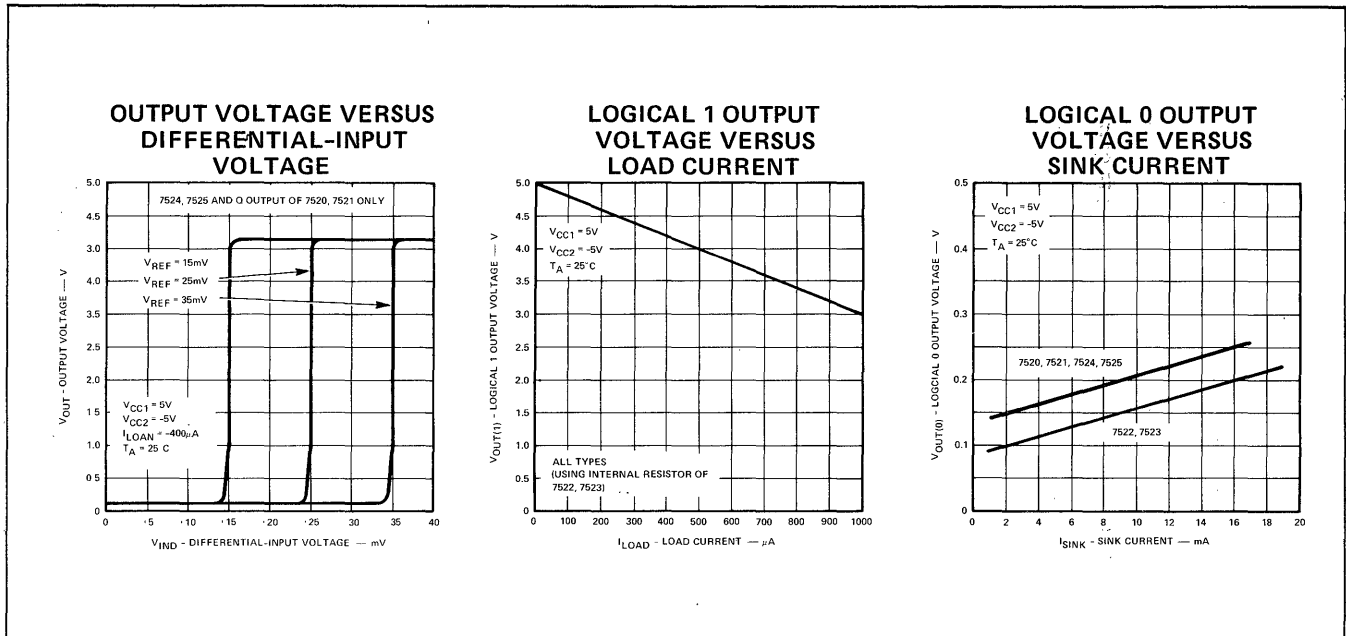

SWITCHING CHARACTERISTICS (Propagation Delay Times)

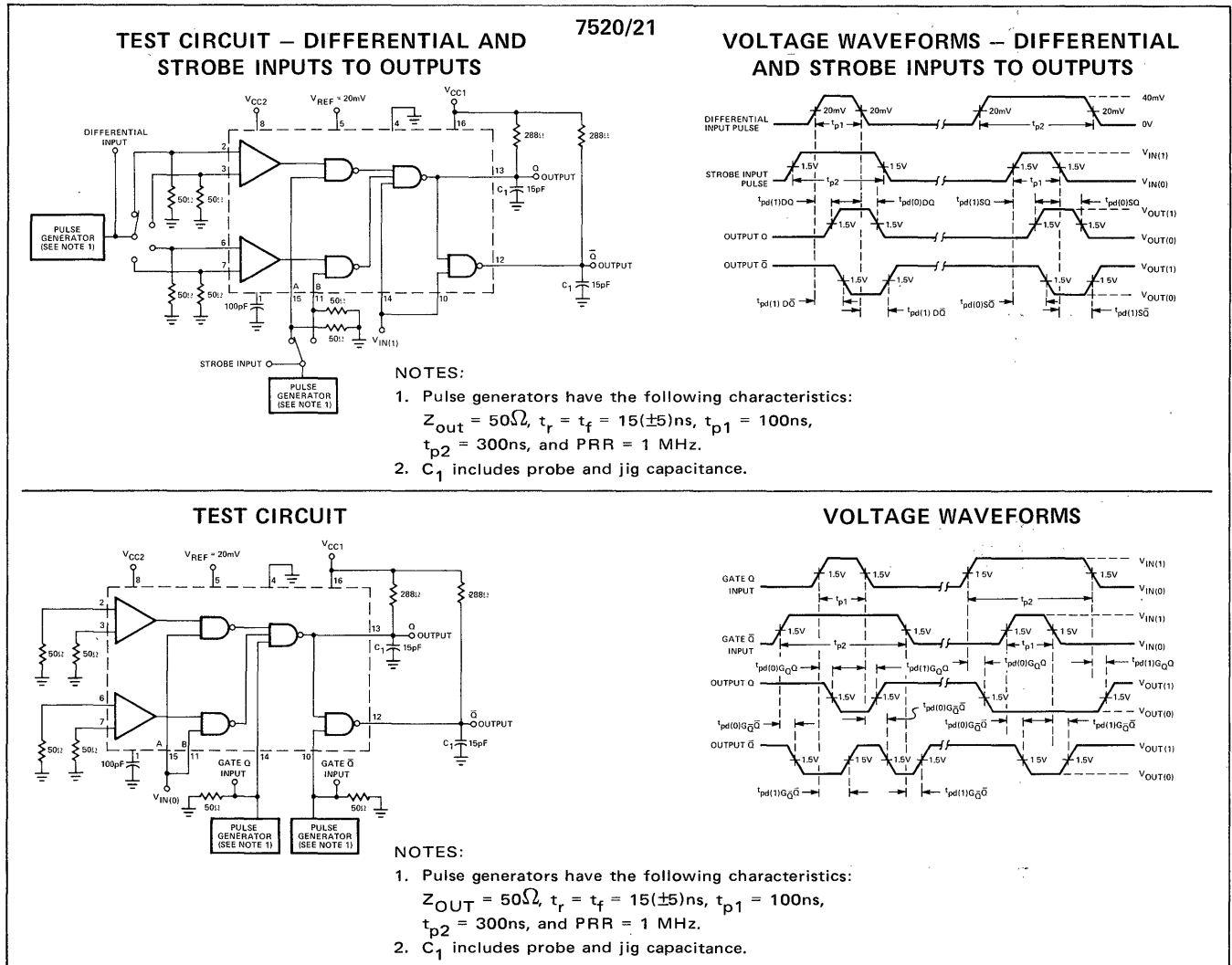

SWITCHING CHARACTERISTICS (Propagation Delay Times)(Cont'd)

7522/23

TEST CIRCUIT

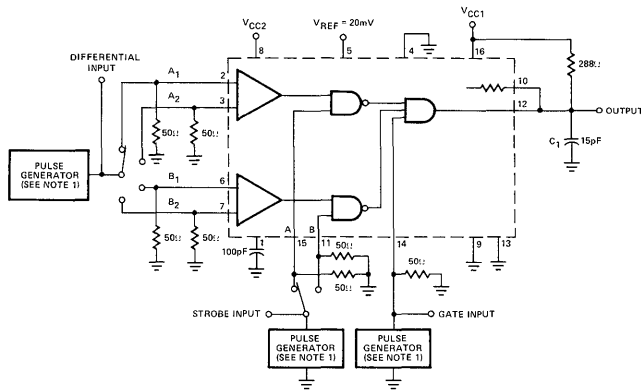

VOLTAGE WAVEFORMS

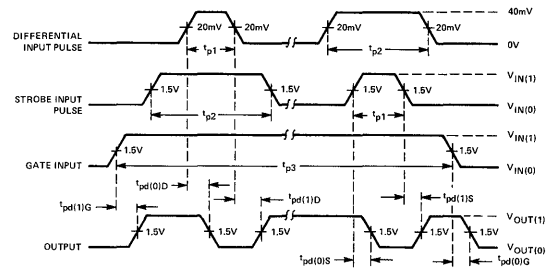

NOTES:

1. Pulse generators have the following characteristics:  
 $Z_{out} = 50\Omega$ ,  $t_r = t_f = 15(\pm 5)ns$ ,  $t_{p1} = 100ns$ ,  
 $t_{p2} = 300ns$ ,  $PRR = 1 MHz$ .
2. Strobe input pulse is applied to Strobe A when inputs  $A_1 - A_2$  are being tested and to Strobe B when inputs  $B_1 - B_2$  are being tested.
3.  $C_1$  includes probe and jig capacitance.

7524/25

TEST CIRCUIT

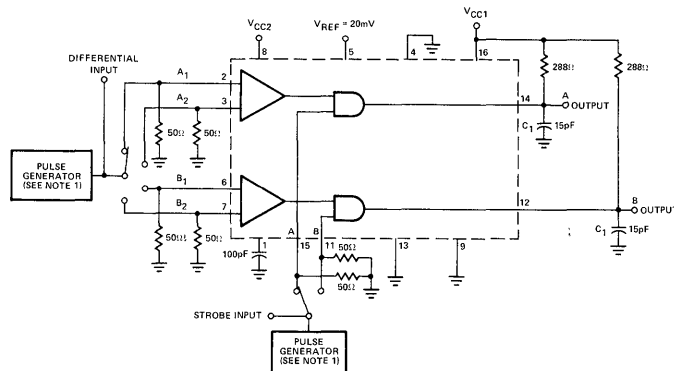

VOLTAGE WAVEFORMS

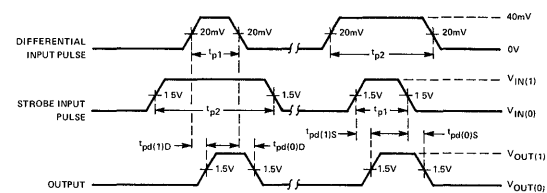

NOTES:

1. Pulse generators have the following characteristics:  
 $Z_{out} = 50\Omega$ ,  $t_r = t_f = 15(\pm 5)ns$ ,  $t_{p1} = 100ns$ ,  
 $t_{p2} = 300ns$ ,  $PRR = 1 MHz$ .
2. Strobe input pulse is applied to Strobe A when inputs  $A_1 - A_2$  are being tested and to Strobe B when inputs  $B_1 - B_2$  are being tested.
3.  $C_1$  includes probe and jig capacitance.

# SECTION 6 communications circuits



## LINEAR INTEGRATED CIRCUITS

### DESCRIPTION

The Signetics NE501 is a direct-coupled broad-band amplifier fabricated within a monolithic silicon substrate by planar and epitaxial techniques. Typical applications include video amplifiers.

Application flexibility is provided by several external pin connections which adjust the amplifier characteristics to individual needs.

### FEATURES

- ADJUSTABLE GAIN AND IMPEDANCE CHARACTERISTICS
- UNITY GAIN FREQUENCY – 150 MHz
- NOISE FIGURE – 5.0dB
- POWER DISSIPATION – 20mW

### ABSOLUTE MAXIMUM RATINGS

Voltage Applied $V_{G,H,E,C}$	+8.0V
Voltage Applied $V_B$	$\pm 3.0V$
Voltage Applied $V_{K,D}$	+4.0V
Current Rating $I_{F,J}$	$\pm 30mA$
Storage Temperature	-65°C to +150°C
Operating Temperature	NE501 0°C to +70°C
	SE501 -55°C to +125°C

### CIRCUIT SCHEMATIC

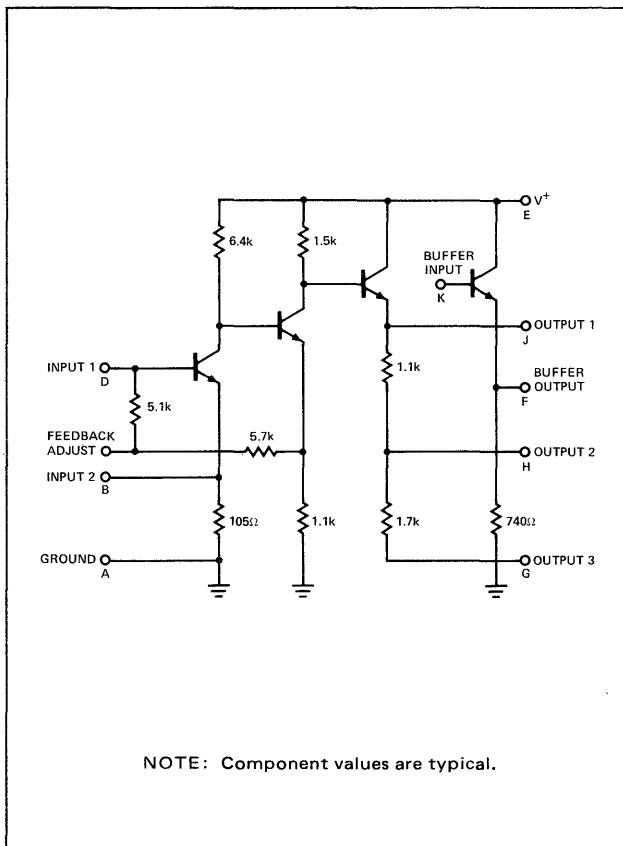

### PIN CONFIGURATIONS

#### A PACKAGE (Top View)

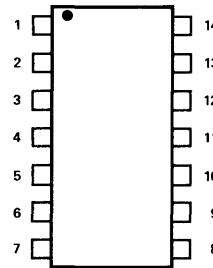

1. Feedback adjust
2. Input 1
3. NC
4. NC
5. Output 3
6. Input 2
7. Ground
8. Output 2
9.  $V^+$
10. NC
11. NC
12. Buffer output
13. Buffer input
14. Output 1

ORDER PART NOS.  
SE501A/NE501A

#### G PACKAGE

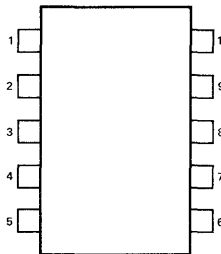

1. Ground
2. Output 3
3. Input 2
4. Output 2
5.  $V^+$
6. Buffer output
7. Buffer input
8. Output 1
9. Feedback adjust
10. Input 1

ORDER PART NOS.  
SE501G/NE501G

#### K PACKAGE

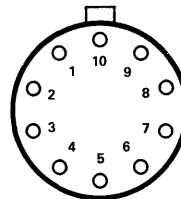

1. Ground
2. Output 3
3. Input 2
4. Output 2
5.  $V^+$
6. Buffer output
7. Buffer input
8. Output 1
9. Feedback adjust
10. Input 1

ORDER PART NOS.  
SE501K/NE501K



ELECTRICAL CHARACTERISTICS

PARAMETER	TEST CONDITIONS	NE501			SE501			UNITS
		MIN	TYP	MAX	MIN	TYP	MAX	
Voltage Gain	f = 50 kHz; Notes 1, 2, 6	22.5	24	26.5	23	24	26	dB
Bandwidth (-3dB)	Notes 1, 2, 6	11			14			MHz
Unity Gain Frequency	$A_{V_0} = 0\text{dB}$ ; Notes 2, 6	100	150		100	150		MHz
Voltage Gain Stability	f = 50 kHz; T = 0°C; Notes 2, 6	-1.0						dB
	f = 50 kHz; T = +70°C; Notes 2, 6			+0.6				dB
	f = 50 kHz; T = -55°C; Notes 2, 6				-1.0			dB
	f = 50 kHz; T = +125°C; Notes 2, 6						+0.6	dB
Output Voltage	Notes 1, 2, 6, 9	0.71	1.0		0.71	1.0		$V_{RMS}$
Input Impedance	Notes 1, 6; f = 50 kHz; $V_J = V_K$	470		1200	540		1100	$\Omega$
Output Impedance	Notes 1, 2; f = 50 kHz; $V_D = \text{AC ground}$		12	18		12	18	$\Omega$
Output Impedance	Notes 1, 5; f = 50 kHz; $V_D = \text{AC ground}$		25	65		25	50	$\Omega$
Power Dissipation				24			21	mW
Power Dissipation	$V_K = V_J$			60			53	mW
Pulse Response								
Delay Time	Notes 2, 6, 7			15			15	ns
Rise Time	Notes 2, 6, 7		12	20		12	16	ns
Noise Figure	f = 100 kHz; BW = 100 Hz; $Z_s = 500\Omega$		5.0	8.0				dB
	$f_c = 100\text{ kHz}$ , BW = 100 Hz; $Z_s = 500\Omega$ , $V_J = V_K$					5.0	7.0	dB

(Notes: 3, 4, 5, 8) Standard Conditions:  $V_E = +6.0\text{V}$ ,  $V_A = 0\text{V}$ ,  $V_G = V_B$ , T = +25°C (except as noted)

NOTES:

- Variations in this parameter depend on optional alternate connections as indicated in accompanying curves.
- Measured at Pin F, with Pins J and K connected.
- Pins not specifically referenced are left electrically open. All voltages are referenced to Pin A. Letter subscripts denote pins on circuit schematic.
- Positive current flow is defined as into the terminal referenced.
- Measured at Pin J.
- Load Resistance =  $600\Omega$ , capacitively coupled.
- Delay time is defined as the time interval between the 50% points of  $e_D$  and  $e_F$ . Rise time = 20% to 80% points of  $e_F$ . Input Pulse Characteristics: Amplitude = 25mV; PW = 100ns.
- See Signetics SURE Program Bulletin No. 5001 for definition of Acceptance test Sub-Groups. Sub-Group A-7 is used for the electrical end points for Linear Products.
- Total harmonic distortion less than 5% at  $e_O = 0.71 V_{RMS}$ .

## LINEAR INTEGRATED CIRCUITS

### DESCRIPTION

The SE/NE592 is a monolithic, two stage, differential input, differential output, wideband video amplifier. It offers fixed gains of 100 and 400 without external components and adjustable gains from 400 to 0 with one external resistor. The input stage has been designed so that with the addition of a few external reactive elements between the gain select terminals, the circuit can function as a high pass, low pass, or band pass filter. This feature makes the circuit ideal for use as a video or pulse amplifier in communications, magnetic memories, display and video recorder systems.

### FEATURES

- 120 MHz BANDWIDTH
- ADJUSTABLE GAINS FROM 0 TO 400
- ADJUSTABLE PASS BAND
- NO FREQUENCY COMPENSATION REQUIRED

### ABSOLUTE MAXIMUM RATINGS

Supply Voltage	±8V
Differential Input Voltage	±5V
Common Mode Input Voltage	±6V
Output Current	10mA
Operating Temperature Range	
SE592K	-55°C to +125°C
NE592K	0°C to + 70°C
Storage Temperature Range	-65°C to +150°C

### CONNECTION DIAGRAM

#### K PACKAGE

(Top View)

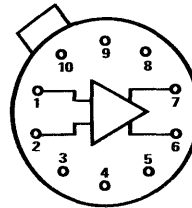

1. Input 1
  2. Input 2
  3. Gain Select G<sub>2B</sub>
  4. Gain Select G<sub>1B</sub>
  5. V<sup>-</sup>
  6. Output 2
  7. Output 1
  8. V<sup>+</sup>
  9. Gain Select G<sub>1A</sub>
  10. Gain Select G<sub>2A</sub>
- NOTE: Pin 5 connected to case.

ORDER PART NOS. SE592K/NE592K

### EQUIVALENT CIRCUIT

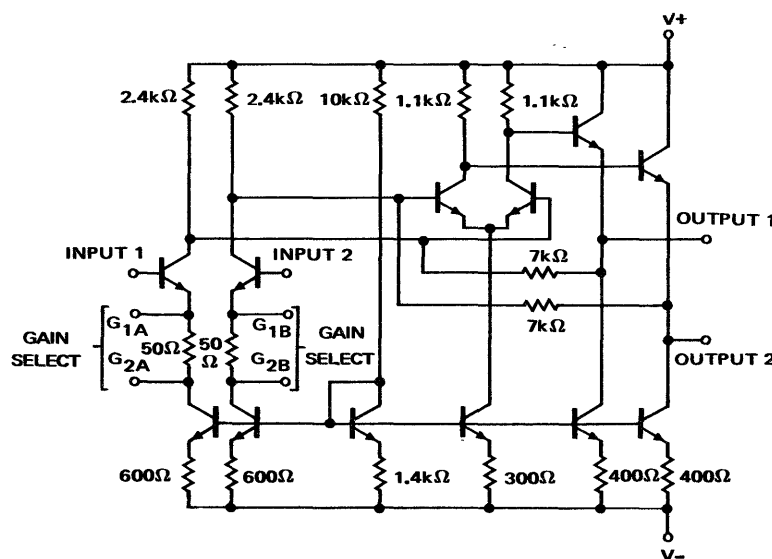



## LINEAR INTEGRATED CIRCUITS

### DESCRIPTION

The 733 is a monolithic differential input, differential output, wideband video amplifier. It offers fixed gains of 10, 100 or 400 without external components, and adjustable gains from 10 to 400 by the use of an external resistor. No external frequency compensation components are required for any gain option. Gain stability, wide bandwidth and low phase distortion are obtained through use of the classic series-shunt feedback from the emitter follower outputs to the inputs of the second stage. The emitter follower outputs provide low output impedance, and enable the device to drive capacitive loads. The 733 is intended for use as a high performance video and pulse amplifier in communications, magnetic memories, display and video recorder systems.

### FEATURES

- 120 MHz BANDWIDTH
- 250k $\Omega$  INPUT RESISTANCE
- SELECTABLE GAINS OF 10, 100 and 400
- NO FREQUENCY COMPENSATION REQUIRED

### ABSOLUTE MAXIMUM RATINGS

Differential Input Voltage	$\pm 5V$
Common Mode Input Voltage	$\pm 6V$
$V_{CC}$	$\pm 8V$
Output Current	10mA
Junction Temperature	+150 $^{\circ}C$
Storage Temperature Range	-65 $^{\circ}C$ to +150 $^{\circ}C$
Operation Temperature Range	

$\mu$ A733C	0 $^{\circ}C$ to +75 $^{\circ}C$
$\mu$ A733	-55 $^{\circ}C$ to +75 $^{\circ}C$

### PIN CONFIGURATIONS

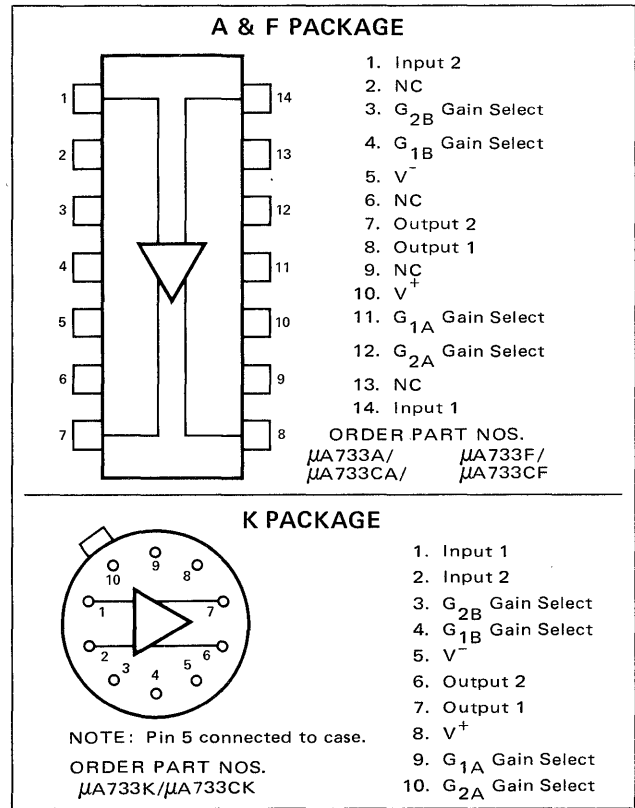

Thermal Resistance ( $\theta_{J-A}$ , Junction to Ambient for each package):

A Package	0.16 $^{\circ}C/mW$
F Package	0.10 $^{\circ}C/mW$
K Package	0.145 $^{\circ}C/mW$
Power Dissipation	500mW

### BASIC CIRCUIT SCHEMATIC

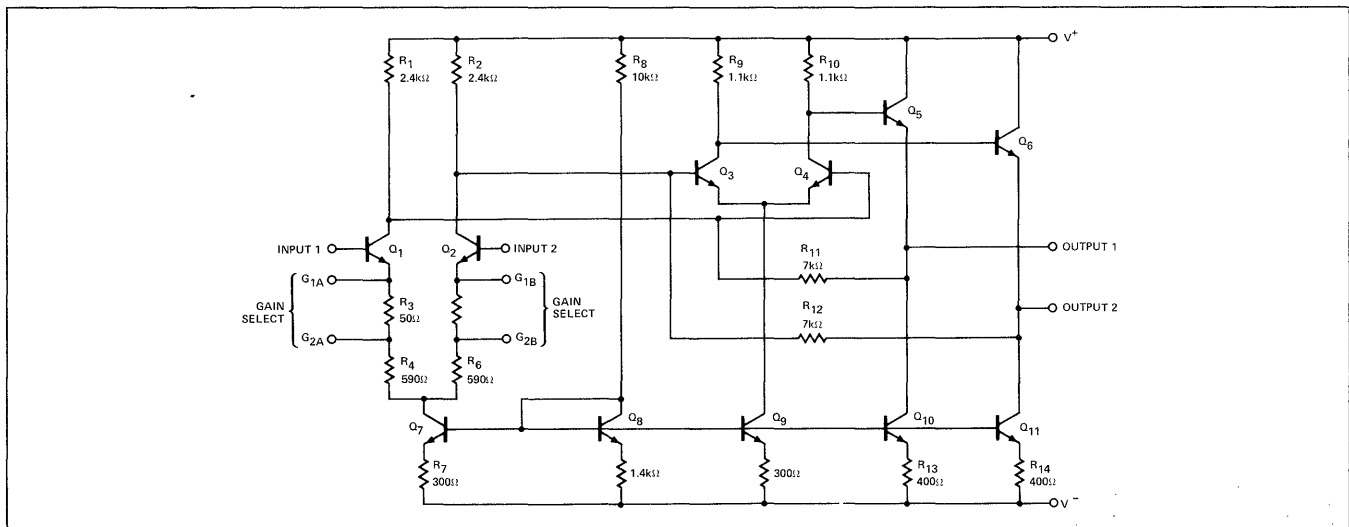

**SIGNETICS ■  $\mu$ A733/ $\mu$ A733C – DIFFERENTIAL VIDEO AMPLIFIER**
**ELECTRICAL CHARACTERISTICS** Standard Conditions ( $T_A = +25^\circ\text{C}$ ,  $V_S = \pm V$ ,  $V_{CM} = 0$  unless otherwise specified)

PARAMETERS	TEST CONDITIONS	$\mu$ A733C			$\mu$ A733			UNITS
		MIN	TYP	MAX	MIN	TYP	MAX	
Differential Voltage Gain								
Gain 1	$R_I = 2\text{k}\Omega$ , $V_{out} = 3V_{p-p}$	Note 1	250	400	600	300	400	500
Gain 2		Note 2	80	100	120	90	100	110
Gain 3		Note 3	8.0	10	12	9.0	10	11
Bandwidth								
Gain 1		Note 1		40		40		MHz
Gain 2		Note 2		90		90		MHz
Gain 3		Note 3		120		120		MHz
Rise Time								
Gain 1	$V_{out} = 1V_{p-p}$	Note 1		10.5		10.5		ns
Gain 2		Note 2		4.5	12	4.5	10	ns
Gain 3		Note 3		2.5		2.5		ns
Propagation Delay								
Gain 1	$V_{out} = 1V_{p-p}$	Note 1		7.5		7.5		ns
Gain 2		Note 2		6.0	10	6.0	10	ns
Gain 3		Note 3		3.6		3.6		ns
Input Resistance								
Gain 1		Note 1		4.0		4.0		$\text{k}\Omega$
Gain 2		Note 2	10	30		20	30	$\text{k}\Omega$
Gain 3		Note 3		250		250		$\text{k}\Omega$
Input Capacitance	Gain 2	Note 2		2.0		2.0		pF
Input Offset Current				0.4	5.0	0.4	3.0	$\mu\text{A}$
Input Bias Current				9.0	30	9.0	20	$\mu\text{A}$
Input Noise Voltage	BW = 1 kHz to 10 MHz			12		12		$\mu\text{V}_{rms}$
Input Voltage Range			$\pm 1.0$			$\pm 1.0$		V
Common Mode Rejection Ratio								
Gain 2	$V_{CM} = \pm 1V$ , $f \leq 100\text{ kHz}$		60	86		60	86	dB
Gain 2	$V_{CM} = \pm 1V$ , $F = 5\text{ MHz}$			60		60		dB
Supply Voltage Rejection Ratio								
Gain 2	$\Delta V_S = \pm 0.5V$		50	70		50	70	dB
Output Offset Voltage								
Gain 1	$R_L = \infty$	Note 1		0.6	1.5	0.6	1.5	V
Gain 2 and 3		Notes 2,3		0.35	1.5	0.35	1.0	V
Output Common Mode Voltage	$R_L = \infty$		2.4	2.9	3.4	2.4	2.9	3.4
Output Voltage Swing	$R_L = 2\text{k}$		3.0	4.0		3.0	4.0	
Output Sink Current			2.5	3.6		2.5	3.6	mA
Output Resistance				20		20		$\Omega$
Power Supply Current	$R_L = \infty$			18	24	18	24	mA

 Recommended Operating Supply Voltages ( $V_S = \pm 6.0V$ )

**NOTES**

- Gain select pins  $G_{1A}$  and  $G_{1B}$  connected together.
- Gain select pins  $G_{2A}$  and  $G_{2B}$  connected together.
- All gain select pins open.

TEST CIRCUITS ( $T_A = 25^\circ\text{C}$  unless otherwise specified)

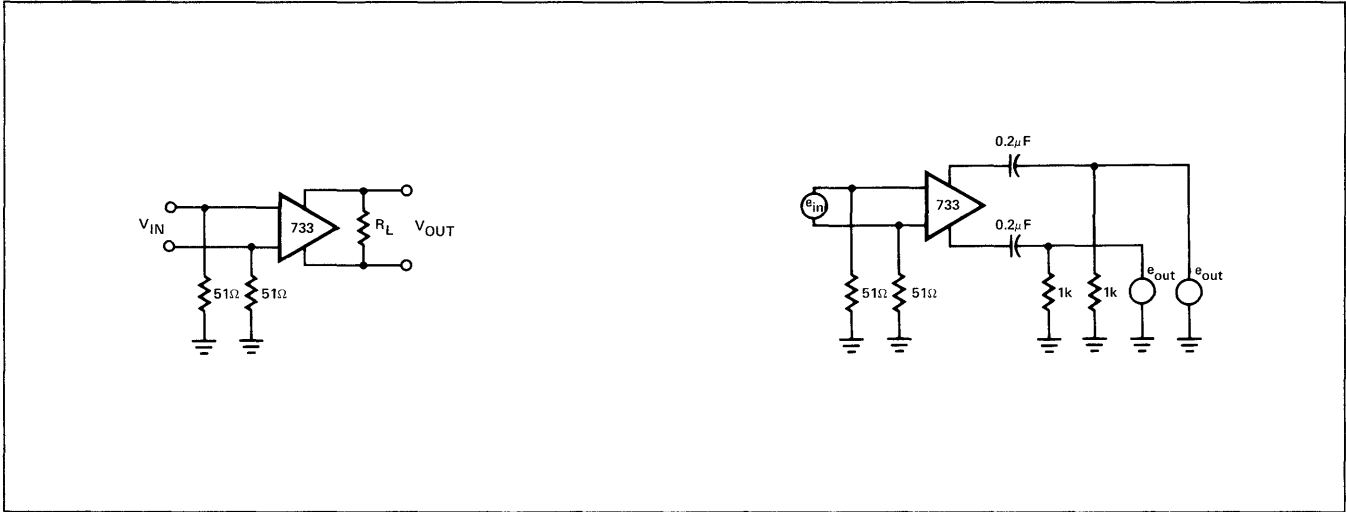

TYPICAL CHARACTERISTIC CURVES

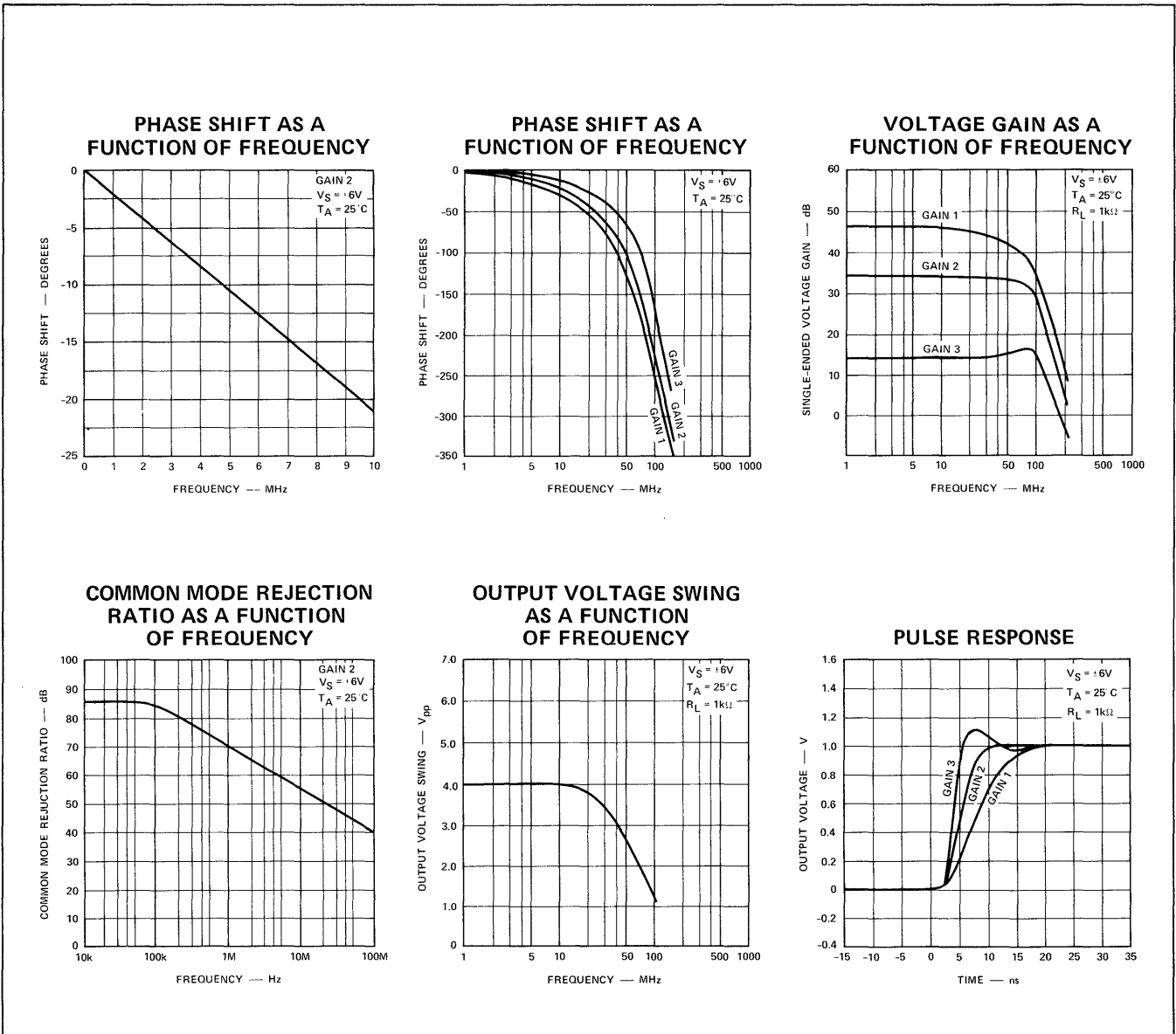

TYPICAL CHARACTERISTIC CURVES (Cont'd.)

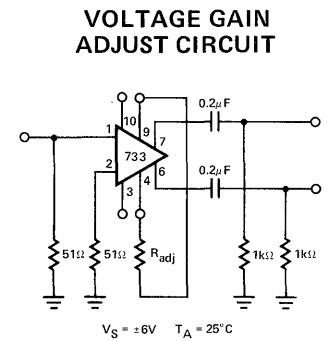
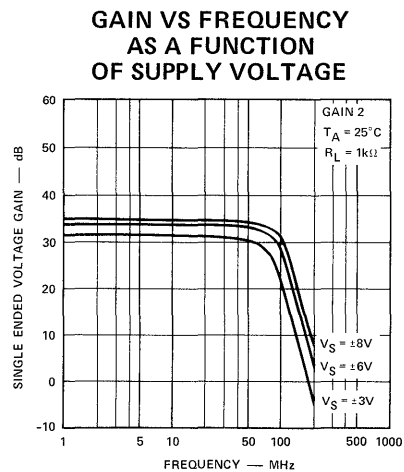
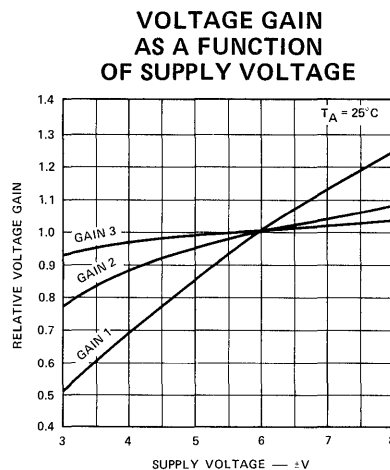
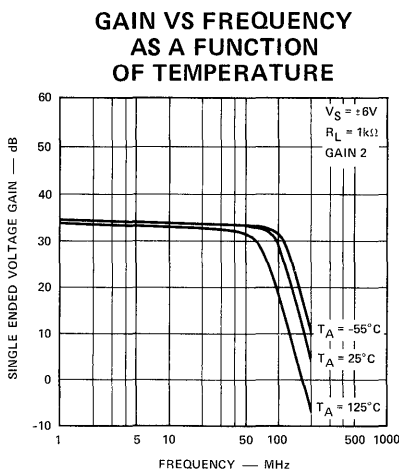
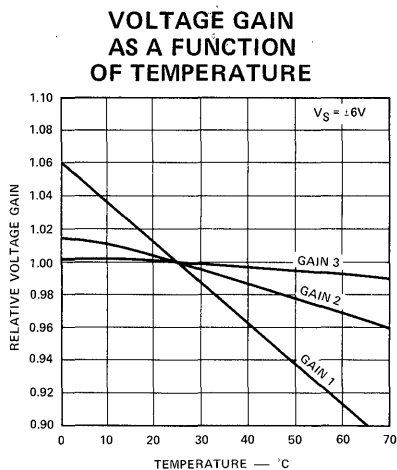
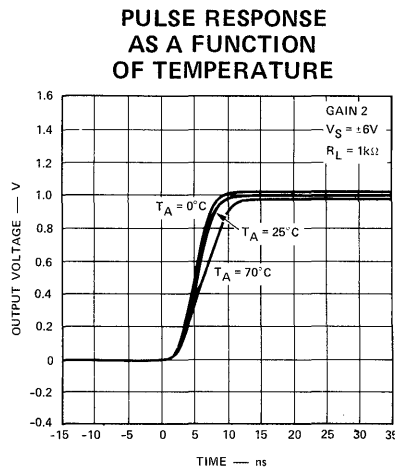
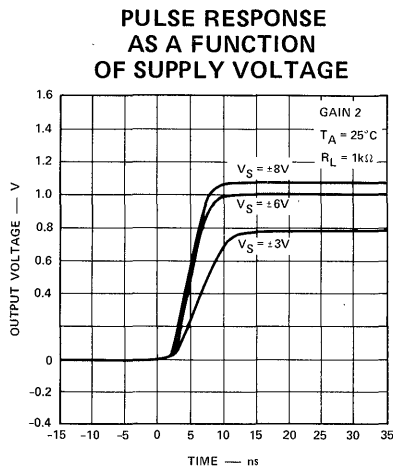
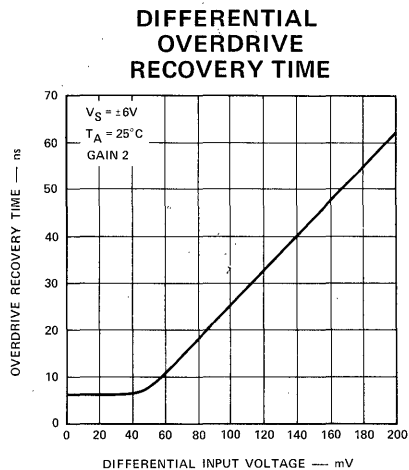

(Pin numbers apply to K Package)

FIGURE 3

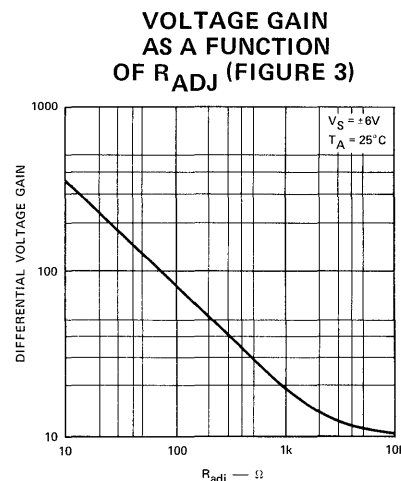

TYPICAL CHARACTERISTIC CURVES (Cont'd.)

SUPPLY CURRENT AS A FUNCTION OF TEMPERATURE

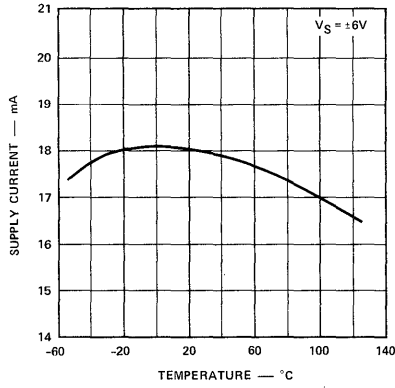

SUPPLY CURRENT AS A FUNCTION OF SUPPLY VOLTAGE

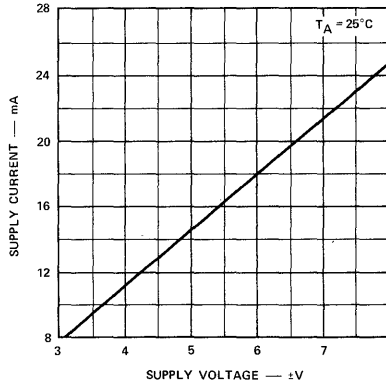

OUTPUT VOLTAGE AND CURRENT SWING AS A FUNCTION OF SUPPLY VOLTAGE

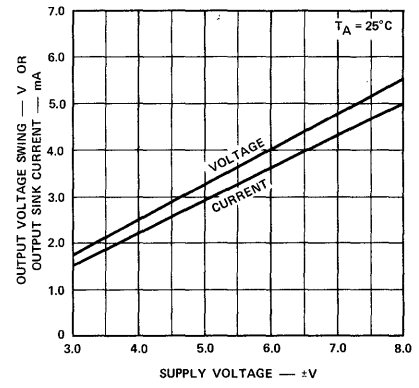

OUTPUT VOLTAGE SWING AS A FUNCTION OF LOAD RESISTANCE

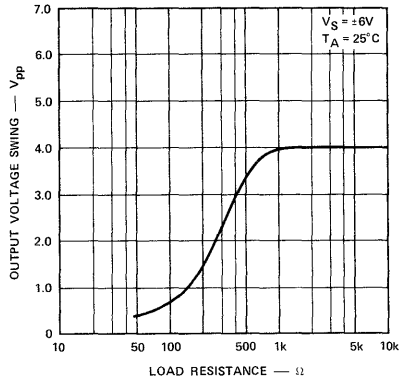

INPUT RESISTANCE AS A FUNCTION OF TEMPERATURE

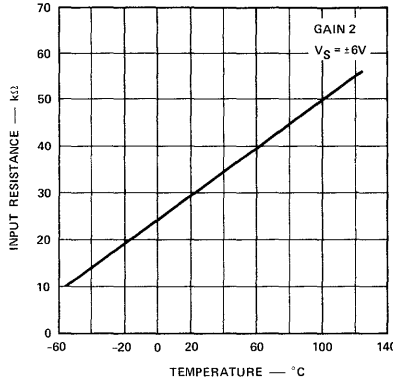

INPUT NOISE VOLTAGE AS A FUNCTION OF SOURCE RESISTANCE

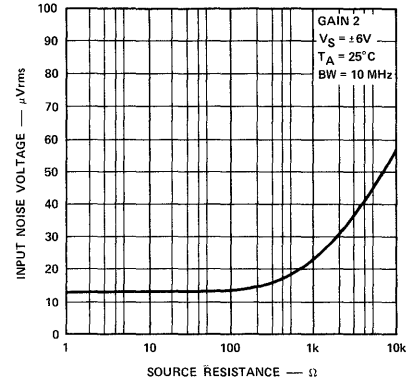





## LINEAR INTEGRATED CIRCUITS

### DESCRIPTION

The 511 is a monolithic dual high frequency differential amplifier with associated constant current source transistors and biasing diode. It is useful from DC to 100 MHz. The circuit arrangement provides for connection as two completely independent emitter coupled (differential) or cascode amplifiers. The bias diode allows stabilization of the current source currents over a large temperature range.

### FEATURES

- LOW INPUT OFFSET VOLTAGE =  $\pm 2\text{mV}$
- LOW INPUT OFFSET CURRENT =  $\pm 3\mu\text{A}$
- AGC CAPABILITY
- HIGH FORWARD TRANSADMITTANCE
- LOW FEEDBACK CAPACITANCE
- SINGLE POWER SUPPLY

### ABSOLUTE MAXIMUM RATINGS

Applied Voltage (V+)	20V
Output Collector Voltage	25V
Current (All Pins)	$\pm 15\text{mA}$
Storage Temperature	$-65^\circ\text{C}$ to $+150^\circ\text{C}$
Operating Temperature	
SE511R, SE511B	$-55^\circ\text{C}$ to $+125^\circ\text{C}$
NE511B, NE511R	$0^\circ\text{C}$ to $+75^\circ\text{C}$
Junction Temperature	$150^\circ\text{C}$

Maximum ratings are limiting values above which serviceability may be impaired.

### PIN CONFIGURATIONS

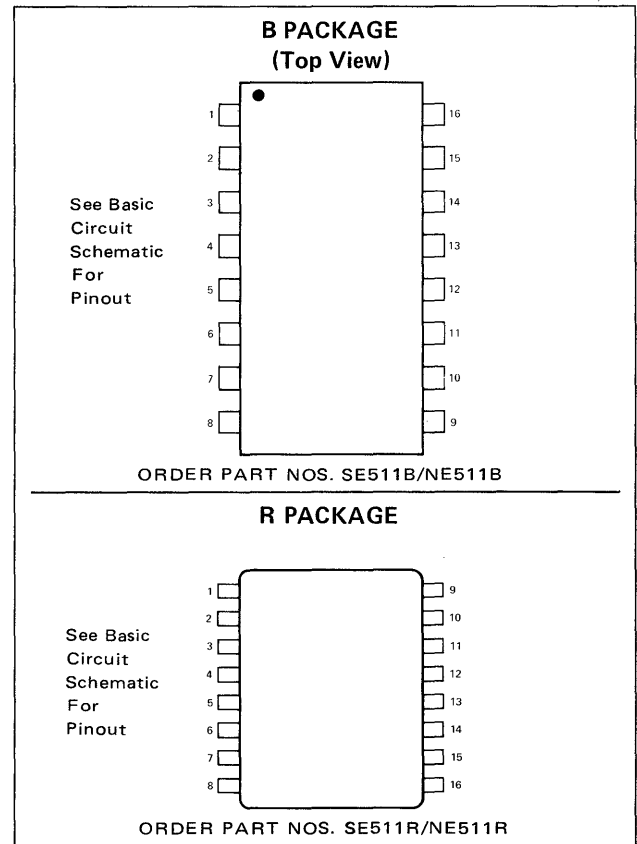

### ELECTRICAL CHARACTERISTICS (Standard Test Circuit)

ACCEPTANCE TEST SUBGROUP	PARAMETERS	SYMBOL	LIMITS						UNITS	TEMPERATURE	TEST CONDITIONS
			MIN		TYP		MAX				
			SE511	NE511	SE511	NE511	SE511	NE511			
A-3	Input Offset Voltage	$\Delta V_{in}$			0.5	0.5	2	3	mV	$+25^\circ\text{C}$	$V_{in} = 0;$ $I_p = 2\text{mA}$
A-4		$\Delta V_{in}$				1.0	4.0		$0^\circ\text{C}$ to $+75^\circ\text{C}$		
A-5		$\Delta V_{in}$			1.5		3.5		$-55^\circ\text{C}$ to $+125^\circ\text{C}$		
A-3	Input Offset Current	$\Delta I_{in}$			2.0	2.0	3.5	6	$\mu\text{A}$	$+25^\circ\text{C}$	
A-4		$\Delta I_{in}$				2.5		9		$0^\circ\text{C}$ to $+75^\circ\text{C}$	
A-5		$\Delta I_{in}$			2.5		7.5		$-55^\circ\text{C}$ to $+125^\circ\text{C}$		
A-3	Input Bias Current	$I_{in}$			8.0	8.0	20	25	$\mu\text{A}$	$+25^\circ\text{C}$	
A-4		$I_{in}$				10.0		40		$0^\circ\text{C}$ to $+75^\circ\text{C}$	
A-5		$I_{in}$			16.0		40		$-55^\circ\text{C}$ to $+125^\circ\text{C}$		
A-3	Differential Collector Current per differential pair	$\Delta I_c$			45	45	62.5	75	$\mu\text{A}$	$+25^\circ\text{C}$	
A-4		$\Delta I_c$				50		100		$0^\circ\text{C}$ to $+75^\circ\text{C}$	
A-5		$\Delta I_c$			50		100		$-55^\circ\text{C}$ to $+125^\circ\text{C}$		
A-3	Differential Current in the Current Sources	$\Delta I_p$			30	30	62.5	75	$\mu\text{A}$	$+25^\circ\text{C}$	
A-4		$\Delta I_p$				35		100		$0^\circ\text{C}$ to $+75^\circ\text{C}$	
A-5		$\Delta I_p$			35		100		$-55^\circ\text{C}$ to $+125^\circ\text{C}$		
A-2	Total Current	$I_{cc}$			11.0	11.0	15.0	15.0	mA	$+25^\circ\text{C}$	
A-3	Common Mode Rejection Ratio	CMRR	60	60	80	80			dB	$+25^\circ\text{C}$	
A-3	Output Conductance	$G_{22}$			0.01	0.01			mmho	$+25^\circ\text{C}$	
C-2	Output Capacitance	$C_{ob}$			2.5	2.5			pF	$+25^\circ\text{C}$	
C-2	Input Capacitance	$C_{ib}$			10	10			pF	$+25^\circ\text{C}$	

**SIGNETICS ■ 511 – DUAL DIFFERENTIAL AMPLIFIER**

**STANDARD TEST CIRCUIT**

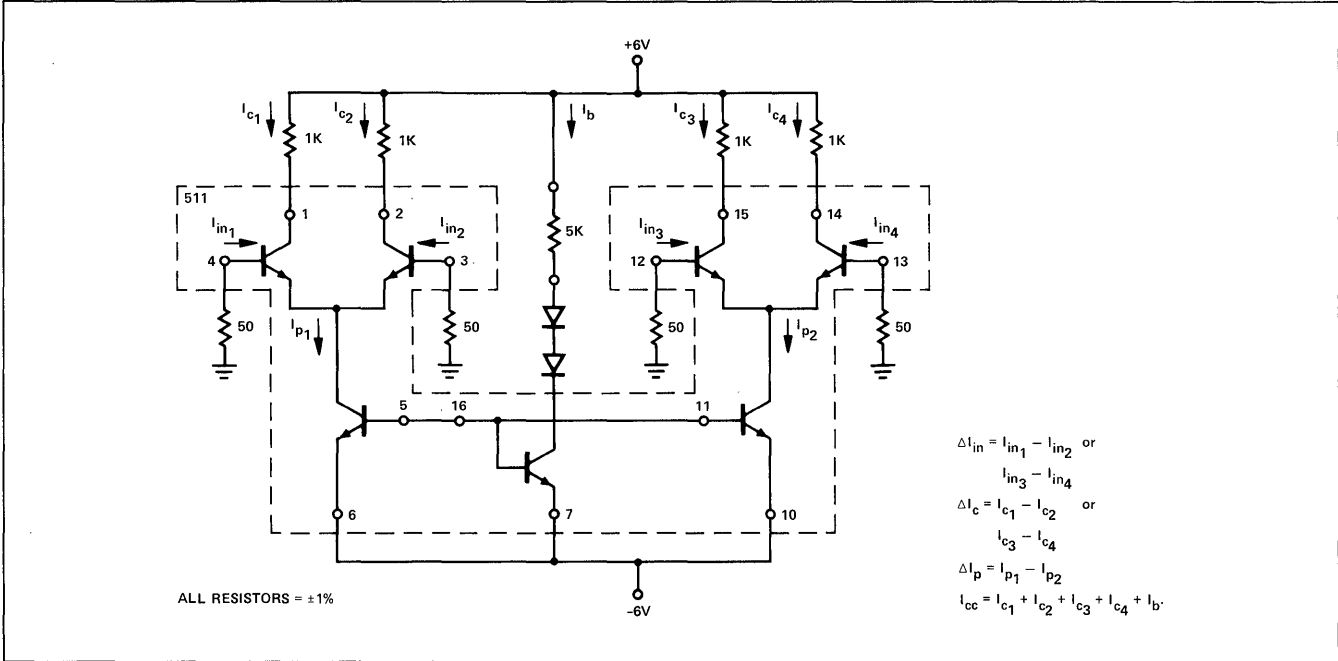

**BASIC CIRCUIT SCHEMATIC**

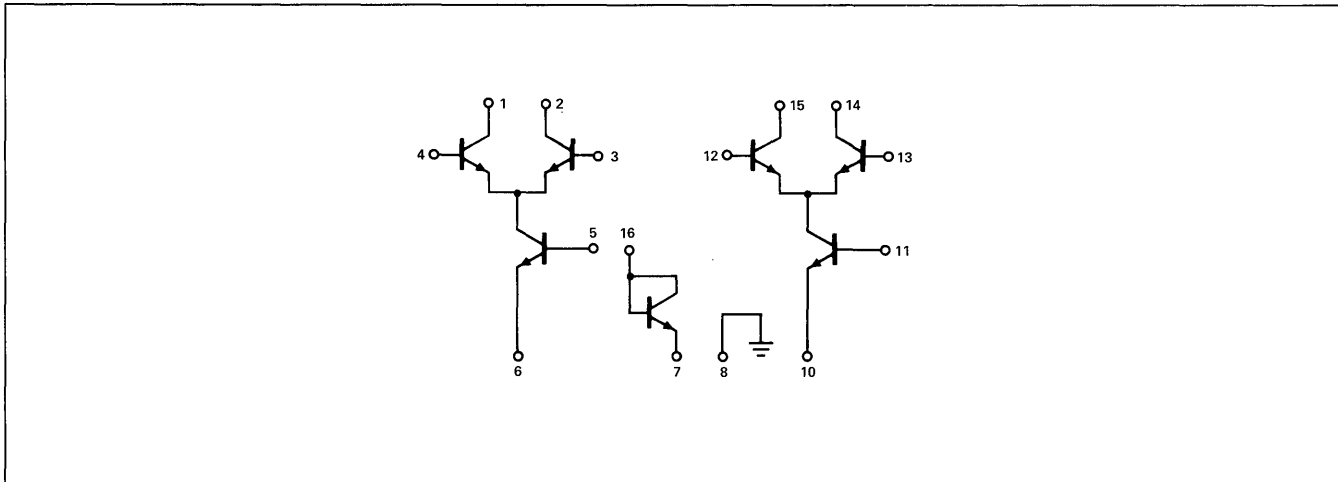

## LINEAR INTEGRATED CIRCUITS

### DESCRIPTION

The 515 is a general purpose high-gain amplifier with differential input and output. It is fabricated within a monolithic silicon substrate by planar and epitaxial techniques. A pair of compensation points is provided to allow frequency compensation for stable closed loop operation.

This device is not internally referenced to ground and with proper input bias may be operated from a single power supply.

### FEATURES

- DIFFERENTIAL VOLTAGE GAIN (Open Loop) = 4,500
- INPUT OFFSET VOLTAGE = 0.5mV
- INPUT OFFSET VOLTAGE STABILITY =  $5.0\mu\text{V}/^\circ\text{C}$
- INPUT COMMON MODE RANGE = +1.5V, -1.0V
- COMMON MODE REJECTION RATIO = 100dB
- BANDWIDTH (Open Loop) = 1.0 MHz

### ABSOLUTE MAXIMUM RATINGS

Applied Voltage ( $V^+$ to $V^-$ )	12V
Differential Input Voltage ( $V_5$ to $V_7$ )	$\pm 5.0\text{V}$
Input Current ( $I_5, I_7$ )	$\pm 2.0\text{mA}$
Output Current ( $I_2, I_{10}$ )	$\pm 30\text{mA}$
Storage Temperature	$-65^\circ\text{C}$ to $+150^\circ\text{C}$
Operating Temperature	$0^\circ\text{C}$ to $+75^\circ\text{C}$
Junction Temperature	$150^\circ\text{C}$

Maximum ratings are limiting values above which serviceability may be impaired.

### EQUIVALENT CIRCUIT

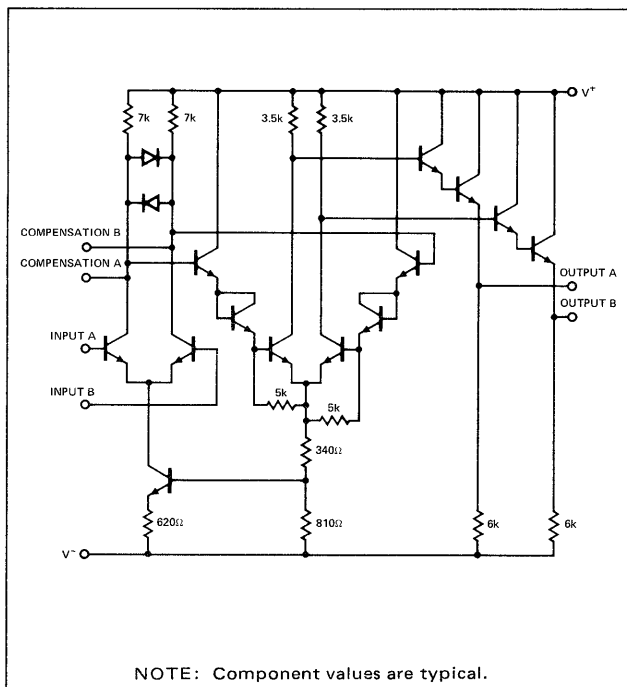

### PIN CONFIGURATIONS

#### A PACKAGE

(Top View)

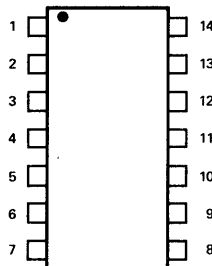

1. Input B
2. NC
3. NC
4. Compensation
5. NC
6. Output B
7.  $V^-$
8. Output A
9. NC
10. NC
11. Compensation
12. NC
13. Input A
14.  $V^+$

ORDER PART NO. NE515A

#### G PACKAGE

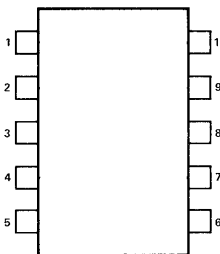

1.  $V^-$
2. Output A
3. NC
4. Compensation
5. Input A
6.  $V^+$
7. Input B
8. Compensation
9. NC
10. Output B

ORDER PART NOS. SE515G/NE515G

#### K PACKAGE

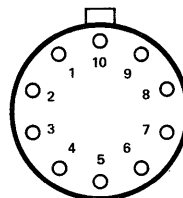

1.  $V^-$
2. Output A
3. NC
4. Compensation
5. Input A
6.  $V^+$
7. Input B
8. Compensation
9. NC
10. Output B

ORDER PART NOS. SE515K/NE515K

**SIGNETICS ■ 515 – DIFFERENTIAL AMPLIFIER**

**SE515 ELECTRICAL CHARACTERISTICS** (Standard Conditions:  $V_7 = 0V$ ,  $V_1 = -3.0V$ ; Notes: 4, 5, 6, 7, 8, 9)

CHARACTERISTIC	$V_6 = +4.0V$	$V_6 = +6.0V$			UNITS	TEMP	TEST CONDITIONS
	TYP	MIN	TYP	MAX			
Open Loop Voltage Gain (dc)	2,500	3,500	4,500		V/V	+25°C	Note 2
	1,800		3,000		V/V	+125°C	
Open Loop Voltage Gain (ac)	2,000	2,500	3,500		V/V	+25°C	f = 800 kHz
Input Offset Voltage	0.5		0.5	3.0	mV	-55°C	Note 1
	0.5		0.5	2.0	mV	+25°C	
	0.5		0.5	3.0	mV	+125°C	
Input Bias Current	18		25	40	$\mu A$	-55°C	Note 1
	12		16	24	$\mu A$		
Differential Input Resistance	2.0	1.0	1.5		k $\Omega$	-55°C	Note 10
	4.0	2.0	3.2		k $\Omega$	+25°C	
Input Common Mode Range	$\pm 1.0$		+1.5		V	+25°C	
			-1.0				
Balanced Output dc Level	-0.1		+1.2	+1.8	V	-55°C	Note 1
	+0.3		+1.6		V	+25°C	
	+0.6		+1.9		V	+125°C	
Output Voltage Swing	4.7	5.7	6.3		V	-55°C	Note 3
	4.7	5.7	6.3		V	+25°C	
	4.7	5.7	6.3		V	+125°C	
High Output Level	+2.3	+4.0	+4.3		V	-55°C	$V_5 = 10mV$
	+2.6	+4.3	+4.6		V	+25°C	
	+3.0	+4.7	+5.0		V	+125°C	
Low Output Level	-2.4	-1.7	-2.0		V	-55°C	$V_5 = 10mV$
	-2.1	-1.4	-1.7		V	+25°C	
	-1.7	-1.0	-1.3		V	+125°C	
Output Resistance	100		100		$\Omega$	+25°C	Note 1
Common Mode Rejection Ratio	100		100		dB		
Power Supply Current	3.5		5.5	7.0		mA	Note 1
				7.0		mA	
				7.0		mA	

**NOTES:**

- Adjust  $V_5$  to obtain  $V_2 = V_{10}$ .
- Output voltage swing = 1.3V peak to peak.
- Output voltage swing is guaranteed by output voltage limit tests.
- Voltage and current subscripts refer to pin numbers.
- All measurements are referenced to power supply common. Positive current flow is defined as into the terminal indicated.
- All specifications herein apply for interchange of voltages and currents at Pins 5 and 7.
- Acceptance Test Sub-Group references apply to minimum and maximum limits only.
- The SE515K has Pins 1, 3 and 9 connected to the case. The SE515G has Pins 3 and 9 open.
- See Signetics SURE Program Bulletin No. 5001 for definition of Acceptance Test Sub-Groups. Sub-Group A-7 is used for electrical end points for Linear Products.
- Differential Input Resistance is computed from input bias current.

**NE515 ELECTRICAL CHARACTERISTICS** (Standard Conditions:  $V_B = 0V$ ,  $V_A = 3.0V$ ; Notes: 4, 5, 6, 7, 8, 9)

CHARACTERISTIC	$V_F = +4.0V$	$V_F = +6.0V$			UNITS	TEMP	TEST CONDITIONS
	TYP	MIN	TYP	MAX			
Open Loop Voltage Gain (dc)	1,800	2,500	3,200		V/V	+25°C	Note 2
	1,350		2,200			+75°C	
Open Loop Voltage Gain (ac)	1,500	1,700	2,500		V/V	+25°C	f = 800 kHz
Input Offset Voltage	0.5		0.5	4.0	mV	0°C	Note 1
	0.5		0.5	3.0	mV	+25°C	
	0.5		0.5	4.0	mV	+75°C	
Input Bias Current	18		25	40	μA	0°C	Note 1
	15		20	31	μA	+25°C	
Differential Input Resistance	3.2	1.4	2.3		kΩ	0°C	Note 10
	3.5	1.7	2.6		kΩ	+25°C	
Input Common Mode Range	±1.0		+1.5		V	+25°C	
			-1.0				
Balanced Output dc Level	-0.1		+1.2	+1.8	V	0°C	Note 1
	+0.3		+1.6		V	+25°C	
	+0.6		+1.9		V	+75°C	
Output Voltage Swing	4.5	5.3	6.1		V	0°C	Note 3
	4.5	5.3	6.1		V	+25°C	
	4.5	5.3	6.1		V	+75°C	
High Output Level	+2.3	+3.9	+4.3		V	0°C	$V_C = 10mV$
	+2.5	+4.1	+4.5		V	+25°C	
	+2.8	+4.3	+4.8		V	+75°C	
Low Output Level	-2.2	-1.4	-1.8		V	0°C	$V_C = 10mV$
	-2.0	-1.2	-1.6		V	+25°C	
	-1.7	-1.0	-1.3		V	+75°C	
Output Resistance	100		100		Ω	+25°C	Note 1
Common Mode Rejection Ratio	100		100		dB	+25°C	
Power Supply Current	3.5		5.5	7.0	mA	0°C	Note 1
				7.0	mA	+25°C	
				7.0	mA	+75°C	

Letter subscripts refer to pins on circuit schematic.

NOTES:

- Adjust  $V_C$  to obtain  $V_G = V_H$ .
- Output voltage swing = 1.3V peak to peak.
- Output voltage swing is guaranteed by output voltage limit tests.
- Voltage and current subscripts refer to pin numbers.
- All measurements are referenced by power supply common. Positive current flow is defined as into the terminal indicated.
- All specifications herein apply for interchange of voltages and currents at Pins B and C.
- Acceptance Test Sub-Group references apply to minimum and maximum limits only.
- The NE515K has Pins 1, 3 and 9 connected to the case. The NE515G has Pins 3 and 9 open.
- See Signetics SURE Program Bulletin No. 5001 for definition of Acceptance Test Sub-Groups. Sub-Group A-7 is used for electrical end points for Linear Products.
- Differential Input Resistance is computed from input bias current.



## LINEAR INTEGRATED CIRCUITS

### DESCRIPTION

The 510 is a dual high-frequency differential amplifier with associated constant current sources and biasing elements contained within a silicon monolithic epitaxial substrate. The large number of accessible internal points provide extreme flexibility of application. The 510 is intended for RF-IF amplifier service to beyond 100 MHz. Circuit layout provides for connection as either a high-gain, common-emitter, common-base, cascode amplifier or a common-collector, common-base, differential amplifier that is useful in critical limiter applications. Automatic gain control may be applied to either circuit.

The SE510J and SE510A meet or exceed the mechanical and environmental requirements of MIL-S-19500 over the temperature range of  $-55^{\circ}\text{C}$  to  $+125^{\circ}\text{C}$ .

The NE510A and NE510J are intended for industrial applications over the temperature range of  $0^{\circ}\text{C}$  to  $+75^{\circ}\text{C}$ .

### FEATURES

- LOW INPUT OFFSET VOLTAGE =  $\pm 2\text{mV}$
- LOW INPUT OFFSET CURRENT =  $\pm 3\mu\text{A}$
- SINGLE POWER SUPPLY
- AGC CAPABILITY
- HIGH FORWARD TRANSADMITTANCE
- LOW FEEDBACK CAPACITANCE

### ABSOLUTE MAXIMUM RATINGS

Applied Voltage ( $V^+$ )	20V
Output Collector Voltage	25V
Current (Pin K)	-25mA
Current (All Other Pins)	$\pm 15\text{mA}$
Storage Temperature	$-65^{\circ}\text{C}$ to $+150^{\circ}\text{C}$
Operating Temperature	
SE510J, SE510A	$-55^{\circ}\text{C}$ to $+125^{\circ}\text{C}$
NE510A, NE510J	$0^{\circ}\text{C}$ to $+75^{\circ}\text{C}$
Junction Temperature	$150^{\circ}\text{C}$

Maximum ratings are limiting values above which serviceability may be impaired.

### BASIC CIRCUIT SCHEMATIC

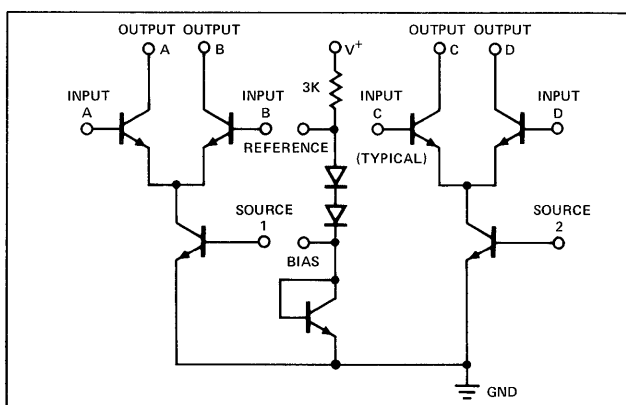

### PIN CONFIGURATIONS

#### A PACKAGE (Top View)

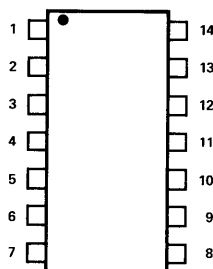

1. Output B
2. Output A
3. Input A
4. Input B
5. Reference
6. Source 1
7. Ground
8. Source 2
9. Bias
10. Input D
11. Input C
12. Output C
13. Output D
14.  $V^+$

ORDER PART NOS. SE510A/NE510A

#### J PACKAGE

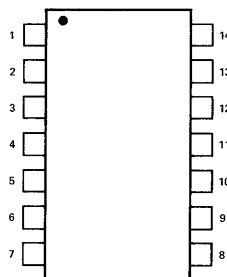

1. Input C
2. Output C
3. Output D
4.  $V^+$
5. Output B
6. Output A
7. Input A
8. Input B
9. Reference
10. Source 1
11. Ground
12. Source 2
13. Bias
14. Input D

ORDER PART NOS. SE510J/NE510J



**ELECTRICAL CHARACTERISTICS**

PARAMETERS	TEMPERATURE	TEST CONDITIONS	LIMITS						UNITS
			NE510			SE510			
			MIN	TYP	MAX	MIN	TYP	MAX	
Input Offset Voltage	+25°C 0°C to +70°C -55°C to +125°C	$V_{in} = 0$		0.5	3		0.5	2	mV
Input Offset Current	+25°C 0°C to +70°C -55°C to +125°C			2.0	6		1.5	3.5	$\mu A$
Input Bias Current	+25°C 0°C to +70°C -55°C to +125°C			8.0	25		2.0	3.5	$\mu A$
Differential Collector Current per Differential Pair	+25°C 0°C to +70°C -55°C to +125°C			10.0	40		2.5	7.5	$\mu A$
Differential Current in the Current Sources	+25°C 0°C to +70°C -55°C to +125°C			45	75		16.0	40	$\mu A$
Total Current	+25°C			50	100		50	100	$\mu A$
Common Mode Rejection Ratio	+25°C			30	75		30	62.5	$\mu A$
			35	100		35	100		
			11.0	15.0		11.0	15.0	mA	
			60	80		60	80	dB	

**ELECTRICAL CHARACTERISTICS** ( $V^+ = +12V$ ,  $T = 25^\circ C$  applicable from DC to 10 MHz, unless otherwise noted)

PARAMETER	EMITTER COUPLED CONFIGURATION	CASCODE CONFIGURATION $V_{AGC} = 0V$	UNITS
Input Conductance [ $R_e(Y_{11})$ ]	0.7	3.0	mmho
Output Conductance [ $R_e(Y_{22})$ ]	0.01	0.01	mmho
Input Capacitance	4.5	10	pF
Output Capacitance	2.5	2.5	pF
Reverse Transfer Capacitance	0.05	0.05	pF
Forward Transconductance	25	90	mmho

## LINEAR INTEGRATED CIRCUITS

### DESCRIPTION

The PA239 is a dual low noise preamplifier featuring two identically-matched 68dB gain amplifiers fed from an internal zener regulated power supply. Operation requires only a single power supply and a minimum number of external frequency shaping components.

### FEATURES

- MATCHED OPEN LOOP VOLTAGE GAIN
- LOW AUDIO NOISE
- SINGLE POWER SUPPLY
- WIDE POWER SUPPLY RANGE
- BUILT-IN POWER SUPPLY FILTER
- HIGH INPUT IMPEDANCE
- EMITTER FOLLOWER OUTPUT
- LOW DISTORTION
- SELF BIASING
- MINIMUM NUMBER OF EXTERNAL COMPONENTS
- OUTPUT CIRCUIT IS SHORT CIRCUIT PROTECTED
- HIGH CHANNEL SEPARATION
- VARIETY OF FEEDBACK OPTIONS
- NO CIRCUIT DAMAGE IF PLUGGED IN BACKWARDS
- 7.5V REGULATOR BIAS SOURCE

### ABSOLUTE MAXIMUM RATINGS

Supply Voltage	16V
Temperature	
Storage	-55°C to +150°C
Operating	-30°C to +85°C

### PIN CONFIGURATION

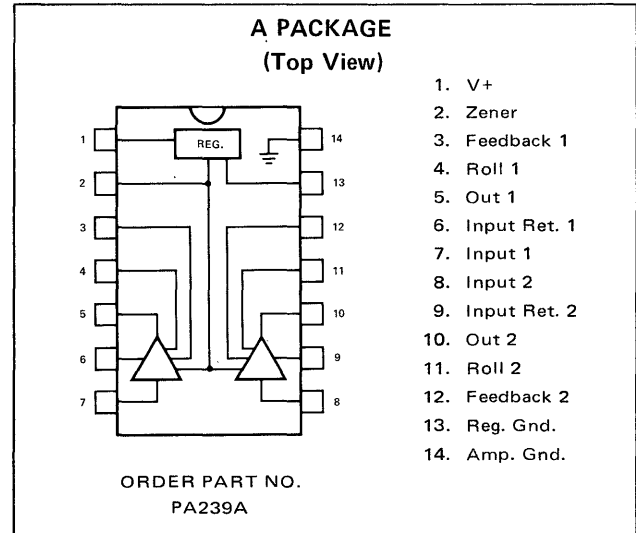

1. V+
2. Zener
3. Feedback 1
4. Roll 1
5. Out 1
6. Input Ret. 1
7. Input 1
8. Input 2
9. Input Ret. 2
10. Out 2
11. Roll 2
12. Feedback 2
13. Reg. Gnd.
14. Amp. Gnd.

### APPLICATIONS

- STEREO TAPE PLAYERS/RECORDERS
- DICTATING EQUIPMENT
- MOVIE PROJECTORS
- PHONOGRAPHS
- TV REMOTE CONTROL RECEIVER
- MICROPHONE AMPLIFIERS
- STEREO RADIO RECEIVER SYSTEMS
- VIDEO PREAMPLIFICATION
- NARROW BAND AMPLIFICATION
- DRIVER-PREAMP FOR LOSSY NETWORKS
- SUPER GAIN CASCADED AMPLIFIERS

### SCHEMATIC DIAGRAM

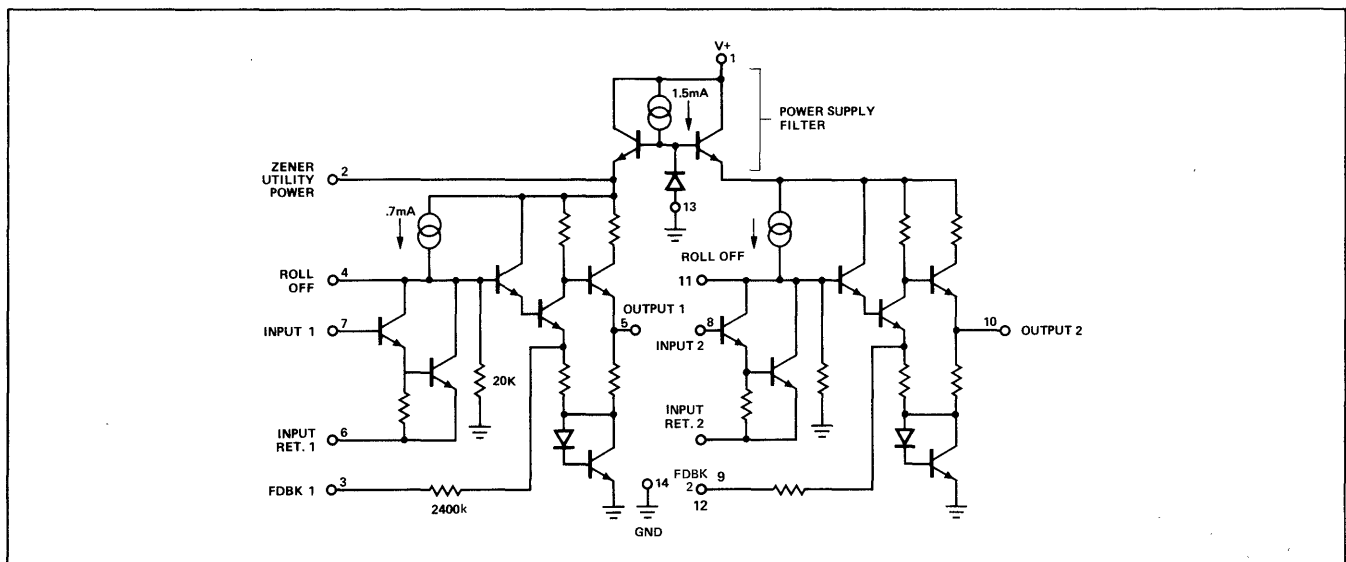

ELECTRICAL CHARACTERISTICS (25°C) (V<sub>CC</sub> = 12V)

PARAMETERS	MIN	TYP	MAX	UNITS
Supply Current (V <sub>CC</sub> = 12V)		16	22	mA
Voltage Gain	65	68	71	dB
Gain Balance		0.3	2	dB
Channel Separation (f = 1 kHz), Figure 1	45	90		dB
Input Resistance	100K	250K		Ω
Signal Output		1.5		V <sub>rms</sub>
Output Resistance		100		Ω
Power Supply Rejection (f = 1 kHz), Figure 2	45	55		dB
Total Harmonic Distortion Without Feedback (0.5V rms into 3kΩ Load, 1 kHz)		0.5	0.9	%
Input dc Bias Current		0.8	3	μA
Gain to Feedback Terminal 3, 12		45		dB
Impedance at Feedback Terminal		2400		Ω
Amplifier Noise Figure (100Hz to 10 kHz, 5kΩ R <sub>s</sub> )		1.8		dB
Equivalent Input Noise (100Hz to 10 kHz, 680Ω R <sub>s</sub> )		0.7	1.2	μV

TEST CIRCUITS

CHANNEL SEPARATION

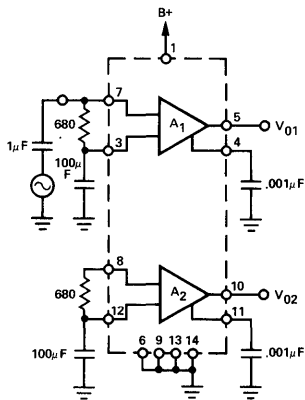

Figure 1

POWER SUPPLY REJECTION

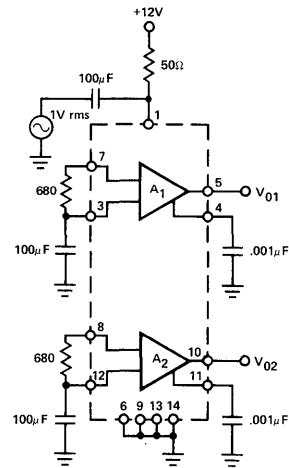

Figure 2

NOISE

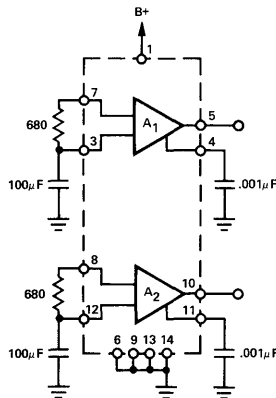

Figure 3

## LINEAR INTEGRATED CIRCUITS

### DESCRIPTION

The 5595 is a Monolithic Four-Quadrant Multiplier designed for uses where the output voltage is a linear product of two input voltages. The S5595F is a pin-for-pin replacement for the MC1595L and the N5595A replaces the MC1495L.

### FEATURES

- EXCELLENT LINEARITY – 1% MAX ERROR ON X-INPUT, 2% MAX ERROR ON Y-INPUT – S5595F
- EXCELLENT LINEARITY – 2% MAX ERROR ON X-INPUT, 4% MAX ERROR ON Y-INPUT – N5595A
- ADJUSTABLE SCALE FACTOR, K
- EXCELLENT TEMPERATURE STABILITY
- WIDE INPUT VOLTAGE RANGE –  $\pm 10$  VOLTS

### APPLICATIONS

- ANALOG MULTIPLICATION AND DIVISION
- SQUARE ROOT OPERATION
- MEAN SQUARING
- PHASE DETECTION
- FREQUENCY DOUBLING
- BALANCED MODULATION/DEMODULATION
- ELECTRONIC GAIN CONTROL

### ABSOLUTE MAXIMUM RATINGS

Applied Voltage	30V	
( $V_2-V_1, V_{14}-V_1, V_1-V_9, V_1-V_{12},$ $V_1-V_4, V_1-V_8, V_{12}-V_7, V_9-V_7,$ $V_8-V_7, V_4-V_7$ )		
Differential Input Signal	$V_{12}-V_9$	$\pm(6 + I_3R_X)V$
	$V_4-V_8$	$\pm(6 + I_3R_Y)V$

### PIN CONFIGURATION

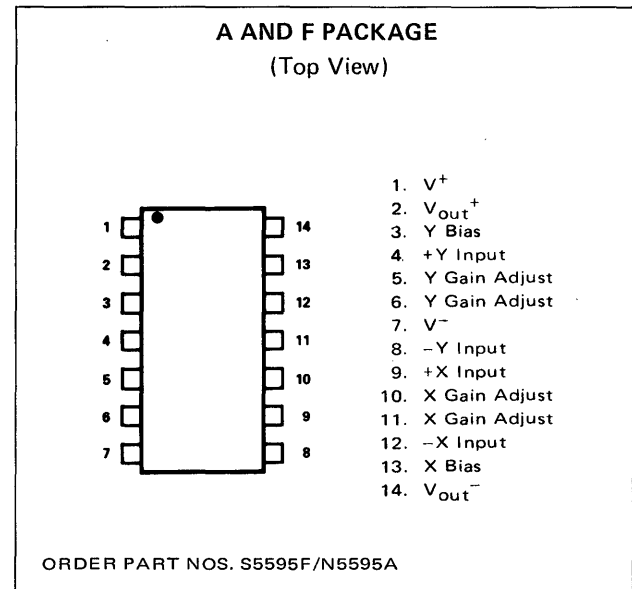

### ABSOLUTE MAXIMUM RATINGS (Cont'd.)

Maximum Bias Current	$I_3$	10mA
	$I_{13}$	10mA
Power Dissipation (Note 1)		
Ceramic Package		750mW
Operating Temperature Range		
S5595F		$-55^\circ\text{C}$ to $+125^\circ\text{C}$
N5595A		$0^\circ\text{C}$ to $+70^\circ\text{C}$
Storage Temperature Range		$-65^\circ\text{C}$ to $+150^\circ\text{C}$

Note 1: Derate linearly at 5mW/ $^\circ\text{C}$  for ambient temperatures above  $+25^\circ\text{C}$

### EQUIVALENT CIRCUIT

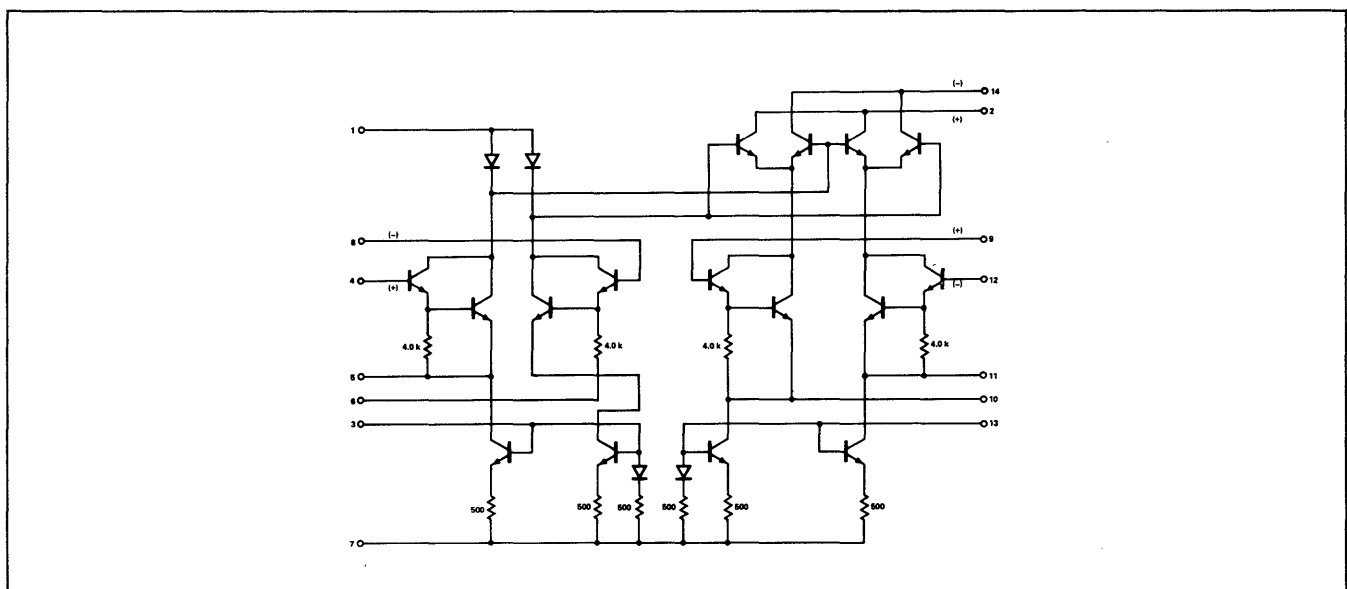

**SIGNETICS S/N5595 – LINEAR INTEGRATED CIRCUITS**

**ELECTRICAL CHARACTERISTICS** ( $V^+ = +32V$ ,  $V^- = -15V$ ,  $T_A = 25^\circ C$ ,  $I_3 = I_{13} = 1\text{ mA}$ ,  $R_X = R_Y = 15\text{ k}\Omega$ ,  $R_L = 11\text{ k}\Omega$  unless otherwise noted)

CHARACTERISTICS	SYMBOL	LIMITS						UNITS	TEMPERATURE	FIGURE
		MIN		TYP		MAX				
		S5595	N5595	S5595	N5595	S5595	N5595			
Linearity: Output Error in Percent of Full Scale: $-10 < V_X < +10 (V_Y = \pm 10V)$	ERX			0.5	1.0	1.0	2.0	%	+25°C 0°C to +70°C -55°C to +125°C	1
$-10 < V_Y < +10 (V_X = \pm 10V)$	ERY			0.75	1.5	2.0	4.0		+25°C 0°C to +70°C -55°C to +125°C	
Squaring Mode Error: Accuracy in Percent of Full Scale After Offset and Scale Factor Adjustment	ESQ			0.5	0.75			%	+25°C 0°C to +70°C -55°C to +125°C	1
Scale Factor (Adjustable) $K = \frac{2R_L}{I_3 R_X R_Y}$	K			0.1	0.1				+25°C	1
Input Resistance (f = 20 Hz)	R <sub>inx</sub> R <sub>iny</sub>			35	20			MΩ	+25°C	2
Differential Output Resistance (f = 20 Hz)	R <sub>o</sub>			300	300			kΩ	+25°C	3
Input Bias Current $I_{bx} = \frac{(I_9 + I_{12})}{2}$ , $I_{by} = \frac{(I_4 + I_8)}{2}$	I <sub>bx</sub> I <sub>by</sub>			2.0	2.0	8.0	12	μA	+25°	4
Input Offset Current  I <sub>q</sub> - I <sub>2</sub>    I <sub>4</sub> - I <sub>8</sub>	I <sub>iox</sub>    I <sub>ioy</sub>			0.2	0.4	1.0	2.0	μA	+25	4
Average Temperature Coefficient of Input Offset Current	ITC <sub>Iio</sub>				2.0	2.0		nA/°C	0°C to +70°C -55 to +70°C	4
Output Offset Current  I <sub>14</sub> - I <sub>2</sub>	I <sub>loo</sub>			10	20	50	100	μA	+25°C	4
Average Temperature Coefficient of Output Offset Current	ITC <sub>Ioo</sub>			20	20			nA/°C	0°C to +70°C -55°C to +125°C	4
Frequency Response 3.0 dB Bandwidth	BW <sub>3dB</sub>			3.0	3.0			MHz	+25°C	5
3° Relative Phase Shift between V <sub>X</sub> and V <sub>Y</sub>	f <sub>φ</sub>			750	750			kHz		
1% Absolute Error Due to Input-Output Phase Shift	f <sub>θ</sub>			30	30			kHz		
Common Mode Input Swing (Either Input)	CMV	±11.5	±10.5	±13	±12			V	+25°C	6
Common Mode Gain (Either Input)	ACM	-50	-40	-60	-50			dB	+25°C	6
Common Mode Quiescent Output Voltage	V <sub>o1</sub> V <sub>o2</sub>			21	21			V	+25°C	1
Differential Output Voltage Swing Capability	V <sub>out</sub>			±14	±14			V	+25°C	1
Power Supply Sensitivity	S <sup>+</sup> S <sup>-</sup>			5.0	5.0			mV/V	+25°C	7
Power Supply Current	I <sub>7</sub>			6.0	6.0	7.0	7.0	mA	+25°C	1
DC Power Dissipation	P <sub>D</sub>			135	135	170	170	mW	+25°C	1



## LINEAR INTEGRATED CIRCUITS

### DESCRIPTION

The 5596 is a monolithic Double-Balanced Modulator/Demodulator designed for use where the output voltage is a product of an input voltage (signal) and a switched function (carrier). The S5596 will operate over the full military temperature range of  $-55^{\circ}\text{C}$  to  $+125^{\circ}\text{C}$ . The N5596 is intended for applications within the range of  $0^{\circ}\text{C}$  to  $+70^{\circ}\text{C}$ .

### FEATURES

- EXCELLENT CARRIER SUPPRESSION
  - 65dB typ @ 0.5 MHz
  - 50dB typ @ 10 MHz
- ADJUSTABLE GAIN AND SIGNAL HANDLING
- BALANCED INPUTS AND OUTPUTS
- HIGH COMMON-MODE REJECTION – 85dB typ

### APPLICATIONS

- SUPPRESSED CARRIER AND AMPLITUDE MODULATION
- SYNCHRONOUS DETECTION
- FM DETECTION
- PHASE DETECTION
- SAMPLING
- SINGLE SIDEBAND
- FREQUENCY DOUBLING

### ABSOLUTE MAXIMUM RATINGS

Applied Voltage (Note 1)	30V
Differential Input Signal ( $V_7 - V_8$ )	$\pm 5.0\text{V}$
Differential Input Signal ( $V_4 - V_1$ )	$\pm(5 + I_5 R_6)\text{V}$
Input Signal ( $V_2 - V_1, V_3 - V_4$ )	5.0V
Bias Current ( $I_5$ )	10mA
Power Dissipation (Pkg. Limitation)	

K-Package	680mW
Derate above $25^{\circ}\text{C}$	$5.4\text{mW}/^{\circ}\text{C}$

A-Package (TO-116)	900mW
Derate above $25^{\circ}\text{C}$	$7.2\text{mW}/^{\circ}\text{C}$

Operating Temperature Range	$-55^{\circ}\text{C}$ to $+125^{\circ}\text{C}$
Storage Temperature Range	$-65^{\circ}\text{C}$ to $+150^{\circ}\text{C}$

### NOTES:

1. Voltage applied between pins 6-7, 8-1, 9-7, 9-8, 7-4, 7-1, 8-4, 6-8, 2-5, 3-5.
2. Pin number references pertain to K package pinout only.

### PIN CONFIGURATIONS

#### A PACKAGE (Top View)

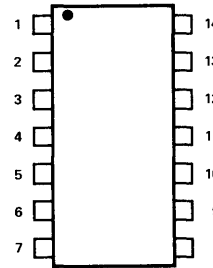

1. Positive Signal Input
2. Gain Adjust
3. NC
4. Gain Adjust
5. Negative Signal Input
6. Bias
7. NC
8. Positive Output
9. Positive Carrier Input
10. Negative Carrier Input
11. NC
12. NC
13. Negative Output
14.  $V^-$

ORDER PART NOS.  
S5596A/N5596A

#### K PACKAGE

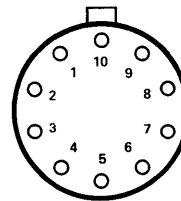

1. Positive Signal Input
2. Gain Adjust
3. Gain Adjust
4. Negative Signal Input
5. Bias
6. Positive Output
7. Positive Carrier Input
8. Negative Carrier Input
9. Negative Output
10.  $V^-$

ORDER PART NOS.  
S5596K/N5596K

### SCHEMATIC DIAGRAM

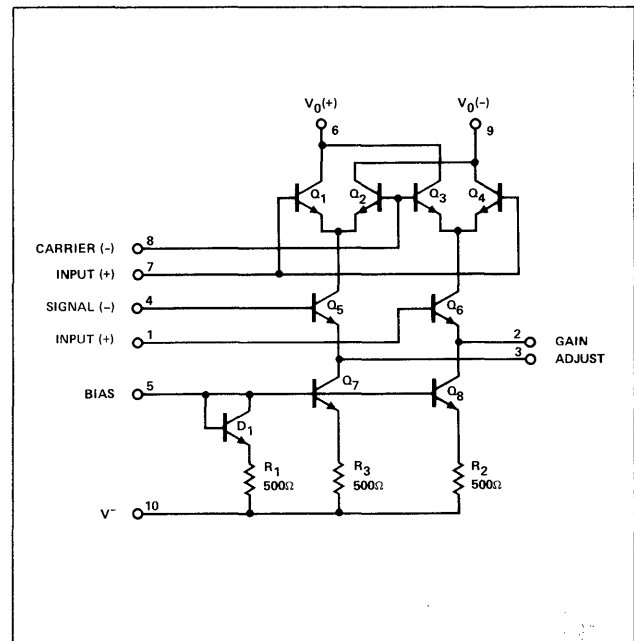

**SIGNETICS ■ 5596 – BALANCED MODULATOR - DEMODULATOR**
**ELECTRICAL CHARACTERISTICS\*** (All input and output characteristics are single-ended unless otherwise noted.)

PARAMETER	S5596			N5596			UNITS
	MIN	TYP	MAX	MIN	TYP	MAX	
Carrier Feedthrough $V_C = 60$ mV(rms) sine wave and offset adjusted to zero $f_C = 1.0$ kHz $f_C = 10$ MHz		40 140			40 140		$\mu$ V (rms)
$V_C = 300$ mVp-p square wave: offset adjusted to zero offset not adjusted $f_C = 1.0$ kHz $f_C = 1.0$ kHz		0.04 20	0.2 100		0.04 20	0.4 200	mV (rms)
CarrierSuppressions $f_S = 10$ kHz, 300 mV(rms) $f_C = 500$ kHz, 60 mV(rms) sine wave $f_C = 10$ MHz, 60 mV(rms) sine wave	50	65 50		40	65 50		dB
Transadmittance Bandwidth (Magnitude) ( $R_L = 50\Omega$ ) Carrier Input Port, $V_C = 60$ mV(rms) sine wave $f_S = 1.0$ kHz, 300 mV(rms) sine wave Signal Input Port, $V_S = 300$ mV(rms) sine wave $ V_C  = 0.5$ V dc		300 80			300 80		MHz
Signal Gain $V_S = 100$ mV(rms), $f = 1.0$ kHz; $ V_C  = 0.5$ V dc	2.5	3.5		2.5	3.5		V/V
Single-Ended Input Impedance, Signal Port, $f = 5.0$ MHz Parallel Input Resistance Parallel Input Capacitance		200 2.0			200 2.0		$k\Omega$ pF
Single-Ended Output Impedance, $f = 10$ MHz Parallel Output Resistance Parallel Output Capacitance		40 5.0			40 5.0		$k\Omega$ pF
Input Bias Current $I_{bS} = \frac{I_1 + I_4}{2}$ ; $I_{bC} = \frac{I_7 + I_8}{2}$		12 12	25 25		12 12	30 30	$\mu$ A
Input Offset Current $I_{ioS} = I_1 - I_4$ ; $I_{ioC} = I_7 - I_8$		0.7 0.7	5.0 5.0		0.7 0.7	7.0 7.0	$\mu$ A
Average Temperature Coefficient of Input Offset Current ( $T_A = -55^\circ\text{C}$ to $+125^\circ\text{C}$ )		2.0			2.0		nA/ $^\circ\text{C}$
Output Offset Current ( $I_6 - I_9$ )		14	50		15	80	$\mu$ A
Average Temperature Coefficient of Output Offset Current ( $T_A = -55^\circ\text{C}$ to $+125^\circ\text{C}$ )		90			90		nA/ $^\circ\text{C}$
Common-Mode Input Swing, Signal Port, $f_S = 1.0$ kHz		5.0			5.0		Vp-p
Common-Mode Gain, Signal Port, $f_S = 1.0$ kHz, $ V_C  = 0.5$ V dc		-85			-85		dB
Common-Mode Quiescent Output Voltage (Pin 6 or Pin 9)		8.0			8.0		Vdc
Differential Output Voltage Swing Capability		8.0			8.0		Vp-p
Power Supply Current $I_6 + I_9$ $I_{10}$		2.0 3.0	3.0 4.0		2.0 3.0	4.0 5.0	mAdc
DC Power Dissipation		33			33		mW

( $V^+ = +12$  V dc,  $V^- = -8.0$  V dc,  $I_5 = 1.0$  mA dc,  $R_L = 3.9$  k $\Omega$ ,  $R_e = 1.0$  k $\Omega$ ,  $T_A = +25^\circ\text{C}$  unless otherwise noted)

\*Pin number references pertain to K package pinout only.



## LINEAR INTEGRATED CIRCUITS

### DESCRIPTION

The 75450 and 75450A are dual peripheral drivers designed for use in systems that employ TTL or DTL logic. These circuits feature two standard 7400 series gates and two uncommitted, high current, high voltage, npn output driver transistors.

### ABSOLUTE MAXIMUM RATINGS

Supply Voltage	+7V
Input Voltage	+5.5V
Collector-Emitter Voltage	+30V
Continuous Collector Current	300mA
Continuous Total Power Dissipation	800mW

### NOTES:

Positive Logic: Y =  $\overline{AG}$  (gate only)  
C = AG (gate and transistor)

### PIN CONFIGURATION

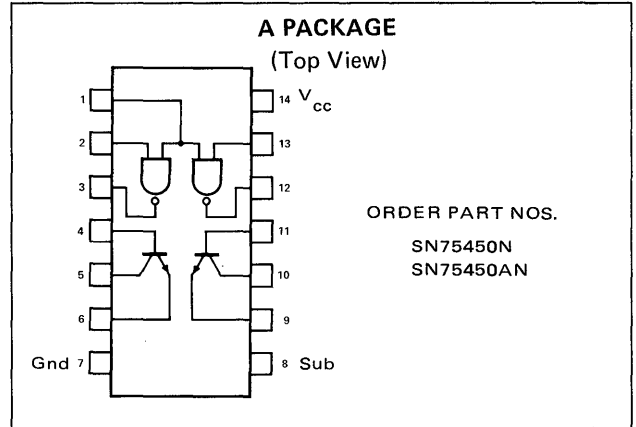

### EQUIVALENT CIRCUIT

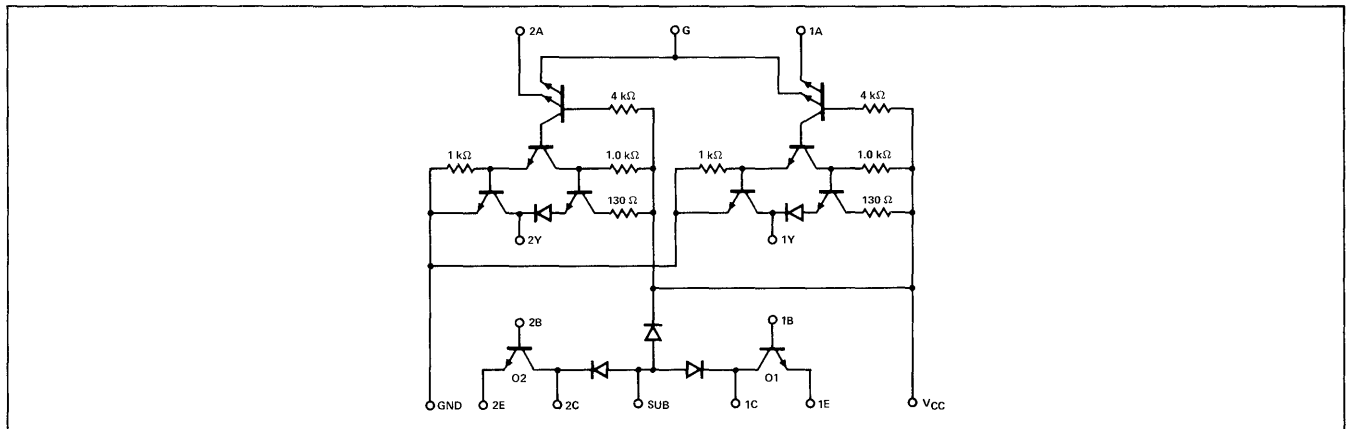

### ELECTRICAL CHARACTERISTICS - TTL GATES ( $V_{CC} = 5V, T_A = 25^\circ C$ )

PARAMETER	TEST CONDITIONS	MIN	TYP	MAX	UNIT
$V_{IH}$ High-Level Input Voltage		2			V
$V_{IL}$ Low-Level Input Voltage				0.8	V
$V_I$ Input Clamp Voltage	$V_{CC} = 4.75V, I_1 = -12mA$			-1.5	V
$V_{OH}$ High-Level Output Voltage	$V_{CC} = 4.75V, V_{IL} = 0.8V, I_{OM} = -400\mu A$	2.4	3.3		V
$V_{OL}$ Low-Level Output Voltage	$V_{CC} = 4.75V, V_{IH} = 2V, I_{OL} = 16mA$		0.22	0.4	V
$I_I$ Input Current at Maximum Input Voltage	Input A Input G $V_{CC} = 5.25V, V_I = 5.5V$			1 2	mA
$I_{IH}$ High-Level Input Current	Input A Input G $V_{CC} = 5.25V, V_I = 2.4V$			40 80	$\mu A$
$I_{IL}$ Low-Level Input Current	Input A Input G $V_{CC} = 5.25V, V_I = 0.4V$			-1.6 -3.2	mA
$I_{OS}$ Short Circuit Output Current	$V_{CC} = 5.25V$	-18		-55	mA
$I_{CCH}$ Supply Current, High-Level Output	$V_{CC} = 5.25V, V_I = 0$		2	4	mA
$I_{CCL}$ Supply Current, Low-Level Output	$V_{CC} = 5.25V, V_I = 5V$		6	11	mA



**SIGNETICS ■ 75450 – DUAL PERIPHERAL DRIVER**

**ELECTRICAL CHARACTERISTICS - OUTPUT TRANSISTORS (Cont'd)**

PARAMETER	TEST CONDITIONS	MIN	TYP	MAX	UNIT
$V_{(BR) CBO}$ Collector-Base Breakdown Voltage	$I_C = 100\mu A, I_E = 0$	35			V
$V_{(BR) CER}$ Collector-Emitter Breakdown Voltage	$I_C = 100\mu A, R_{BE} = 500\Omega$	30			V
$V_{(BR) EBO}$ Emitter-Base Breakdown Voltage	$I_E = 100\mu A, I_C = 0$	5			V
$h_{FE}$ Static Forward Current Transfer Ratio	$V_{CE} = 3V, I_C = 100mA, T_A = 25^\circ C$	25			
	$V_{CE} = 3V, I_C = 300mA, T_A = 25^\circ C$	30			
	$V_{CE} = 3V, I_C = 100mA, T_A = 0^\circ C$	20			
	$V_{CE} = 3V, I_C = 300mA, T_A = 0^\circ C$	25			
$V_{BE}$ Base-Emitter Voltage	$I_B = 10mA, I_C = 100mA$		0.85	1	V
	$I_B = 30mA, I_C = 300mA$		1.05	1.2	V
$V_{CE (sat)}$ Collector-Emitter Saturation Voltage	$I_B = 10mA, I_C = 100mA$		0.25	0.4	V
	$I_B = 30mA, I_C = 300mA$		0.5	0.7	V

**SWITCHING CHARACTERISTICS - TTL GATES ( $V_{CC} = 5V, T_A = 25^\circ C$ )**

PARAMETER	TEST CONDITIONS	75450			75450A			UNIT
		MIN	TYP	MAX	MIN	TYP	MAX	
<b>TTL GATES</b>								
$t_{PLH}$ Propagation Delay Time Low-to-High-Level Output	$C_L = 15pF, R_L = 400\Omega$		12	22		20		ns
$t_{PHL}$ Propagation Delay Time, High-to-High-Level Output			8	15		8		ns
<b>OUTPUT TRANSISTORS</b>								
$t_D$ Delay Time	$I_C = 200mA, I_{B(1)} = 20mA$		8	15		8		ns
$t_r$ Rise Time	$I_{B(2)} = -40mA,$		12	20		12		ns
$t_s$ Storage Time	$V_{BE(off)} = -1V$		7	15		7		ns
$t_f$ Fall Time	$C_L = 15pF, R_L = 50$		6	15		6		ns
<b>GATES AND TRANSISTORS COMBINED</b>								
$t_{PLH}$ Propagation Delay Time, Low-to-High-Level Output	$I_C = 200mA, C_L = 15pF, R_L = 50$		17			40		ns
$t_{PHL}$ Propagation Delay Time, High-to-Low-Level Output			16			25		ns
$t_{TLH}$ Transition Time, Low-to-High-Level Output			7			10		ns
$t_{THL}$ Transition Time, High-to-Low-Level Output			9			12		ns



## LINEAR INTEGRATED CIRCUITS

### DESCRIPTION

The SN75451 and SN75451A dual peripheral drivers are versatile devices designed for use in systems that employ TTL or DTL logic. These circuits are dual AND drivers (positive logic) with the gate outputs internally connected to the npn output transistors.

### ABSOLUTE MAXIMUM RATINGS

Supply Voltage ( $V_{CC}$ )	+7V
Input Voltage	+5.5V
Output Voltage	+30V
Continuous Output Current	300mA
Continuous Power Dissipation	800mW
Positive Logic	Y = AB

### TRUTH TABLE

A	B	Y
L	L	L (on state)
L	H	L (on state)
H	L	L (on state)
H	H	H (off state)

### PIN CONFIGURATION

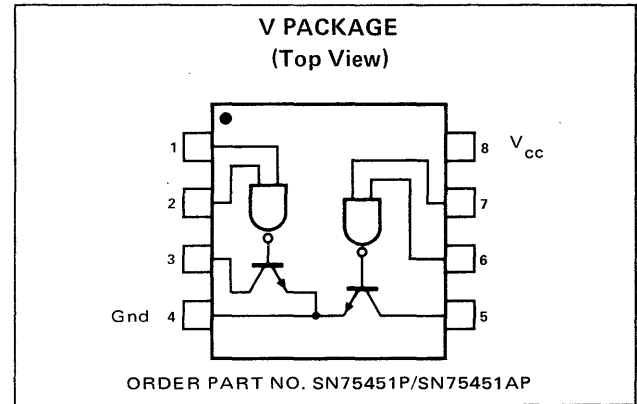

### EQUIVALENT CIRCUIT (Each Driver)

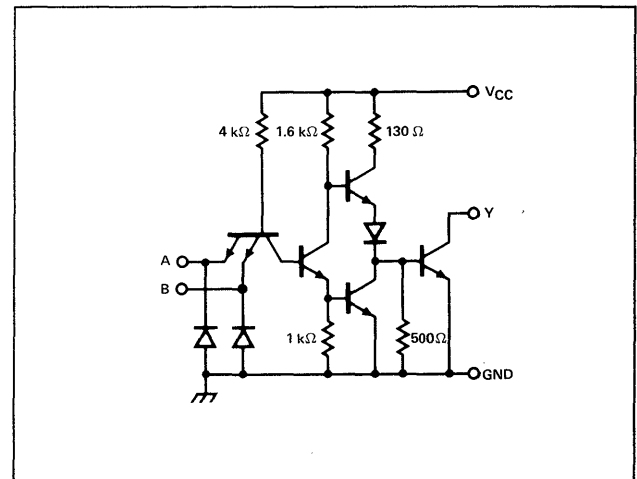

### ELECTRICAL CHARACTERISTICS

PARAMETER	TEST CONDITIONS	MIN	TYP	MAX	UNIT
$V_{IH}$ High-Level Input Voltage		2			V
$V_{IL}$ Low-Level Input Voltage				0.8	V
$V_I$ Input Clamp Voltage	$V_{CC} = 4.75V, I_I = -12mA$			-1.5	V
$I_{OH}$ High-Level Output Current	$V_{CC} = 4.75V, V_{IH} = 2V$ $V_{OH} = 30V$			100	$\mu A$
$V_{OL}$ Low-Level Output Voltage	$V_{CC} = 4.75V, V_{IL} = 0.8V$ $I_{OL} = 100mA$		0.25	0.4	V
	$V_{CC} = 4.75V, V_{IL} = 0.8V,$ $I_{OL} = 300mA$		0.5	0.7	V
$I_I$ Input Current at Maximum Input Voltage	$V_{CC} = 5.25V, V_I = 5.5V$			1	mA
$I_{IH}$ High-Level Input Current	$V_{CC} = 5.25V, V_I = 2.4V$			40	$\mu A$
$I_{IL}$ Low-Level Input Current	$V_{CC} = 5.25V, V_I = 0.4V$		-1	-1.6	mA
$I_{CCH}$ Supply Current, High-Level Output	$V_{CC} = 5.25V, V_I = 5V$		7	11	mA
$I_{CCL}$ Supply Current, Low-Level Output	$V_{CC} = 5.25V, V_T = 0$		52	65	mA

**SIGNETICS ■ N75451/N75451A – DUAL PERIPHERAL DRIVER**

**SWITCHING CHARACTERISTICS** ( $V_{CC} = 5V, T_A = 25^{\circ}C$ )

PARAMETER	TEST CONDITIONS	75451			75451A			UNITS
		MIN	TYP	MAX	MIN	TYP	MAX	
$t_{PLH}$ Propagation Delay Time Low-to-High-Level Output	$I_O \approx 200mA, C_L = 15pF$  $R_L = 50\Omega$		20	25		45		ns
$t_{PHL}$ Propagation Delay Time High-to-Low Level Output			20	30		25		ns
$t_{TLH}$ Transition Time, Low-to- High-Level Output				10		10		ns
$t_{THL}$ Transition Time, High-to- Low-Level Output				10		12		ns

# SECTION 7

## consumer circuits



## LINEAR INTEGRATED CIRCUITS

### DESCRIPTION

The 540 is a monolithic, class AB power amplifier designed specifically to drive a pair of complementary output transistors. The device features low standby current yet retains a high output current drive capability with internal current limiting. A wide power bandwidth and excellent linearity make this device ideal for use as an audio power amplifier.

### FEATURES

- INTERNAL CURRENT LIMITING
- LOW STANDBY CURRENT
- HIGH OUTPUT CURRENT CAPABILITY
- WIDE POWER BANDWIDTH
- LOW DISTORTION

### ABSOLUTE MAXIMUM RATINGS

Supply Voltage	± 27 Volts SE540
	± 22 Volts NE540
Operating Temperature Range	-55°C to +125°C SE540
	0°C to +70°C NE540
Storage Temperature Range	-65°C to +150°C
Output Short Circuit Duration	Indefinite
(Not exceeding maximum dissipation.)	

### PIN CONFIGURATION

L PACKAGE  
(Top View)

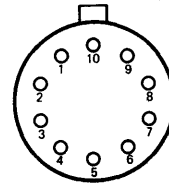

1. Power Limit
2. Non Inverting Input
3. NC
4. Inverting Input
5. Power Limit
6. V<sup>-</sup>
7. Output 1 (emitter)
8. Output 2 (base)
9. Output 3 (collector)
10. V<sup>+</sup>

ORDER PART NOS. SE540L/NE540L

### SCHEMATIC DIAGRAM

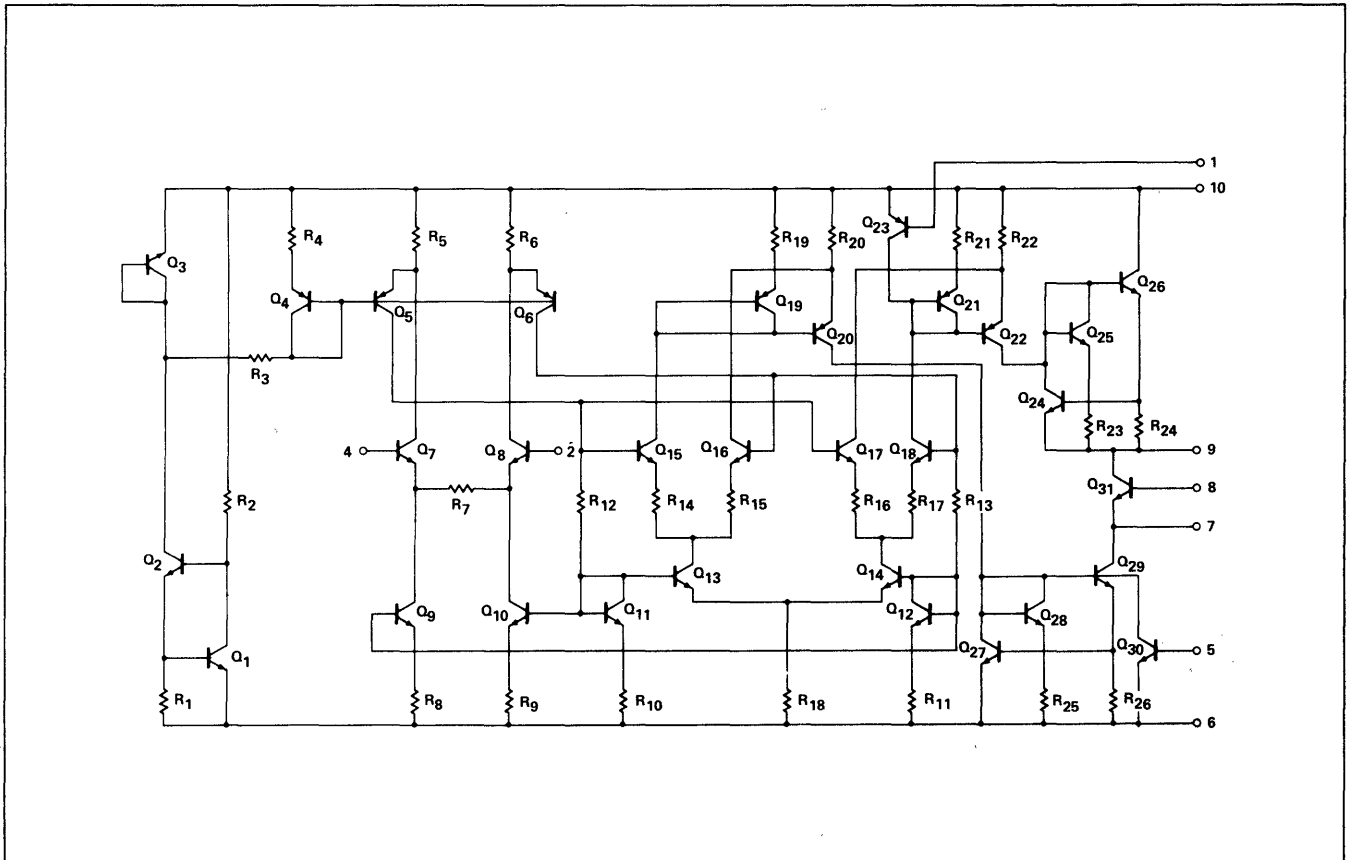

**SIGNETICS ■ SE/NE 540L – POWER DRIVER**

**ELECTRICAL CHARACTERISTICS** ( $T_A = 25^\circ\text{C}$  unless otherwise specified)

PARAMETER	TEST CONDITIONS	SE 540			NE 540			UNIT
		MIN	TYP	MAX	MIN	TYP	MAX	
Operating Temperature Range		-55		+125	0		+70	°C
Operating Supply Voltage		±5		±25	±5		±20	Volts
Quiescent Current			13	20		13	20	mA
Input Offset Voltage			5	7		7	10	mV
Input Offset Current			0.3	0.7		0.5	1	μA
Input Bias Current			1.5	3		2	5	μA
Input Impedance	40 dB Gain		20			20		kΩ
Current Gain		80	100		70	90		dB
Gain Variation Over Temperature Range	40 dB Gain		±0.1			±0.1		dB
Frequency Response	40 dB Gain ±1 dB		500			100		kHz
Distortion	40 dB Gain Output 3 dB below maximum $R_L = 600\Omega$		0.25	0.5		0.5	1.0	%
Equivalent Input Noise Voltage	$R_S = 600\Omega$ 50 Hz to 500 kHz		10			10		μV
Power Supply Rejection Ratio	40 dB Gain	80	90		60	80		dB
Common Mode Rejection Ratio			110			90		dB
Output Drive Current		±120	±150		±80	±100		mA
Slew Rate	$V_S = \pm 20V$ $V_{OUT} = \pm 15V$		200			200		V/μs

**TEST CIRCUITS**

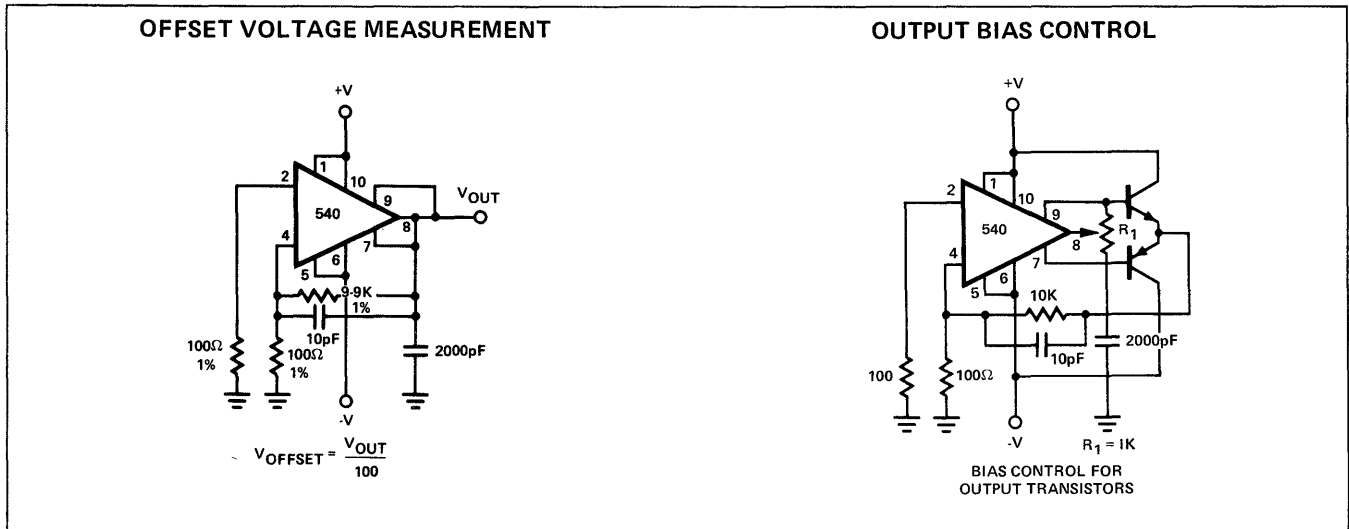

TYPICAL PERFORMANCE CHARACTERISTICS

CLOSED LOOP FREQUENCY RESPONSE

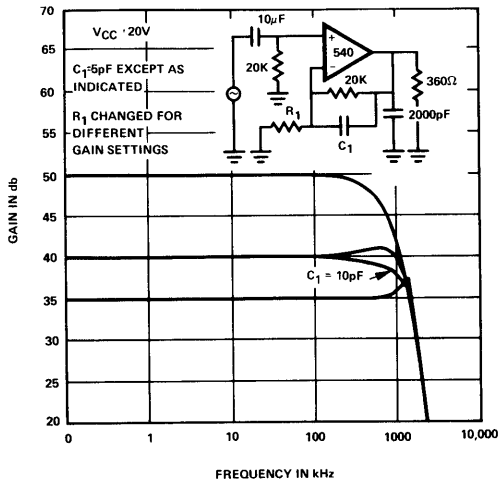

OPEN LOOP GAIN AND FREQUENCY RESPONSE

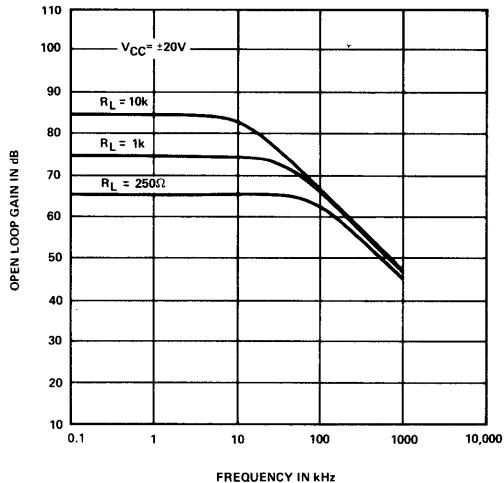

PHASE RESPONSE VERSUS FREQUENCY

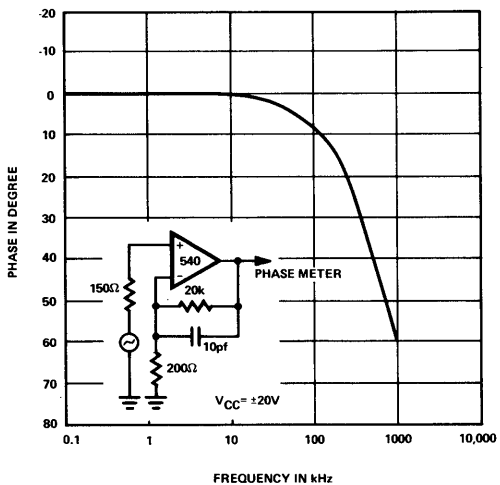

POWER SUPPLY REJECTION VERSUS FREQUENCY

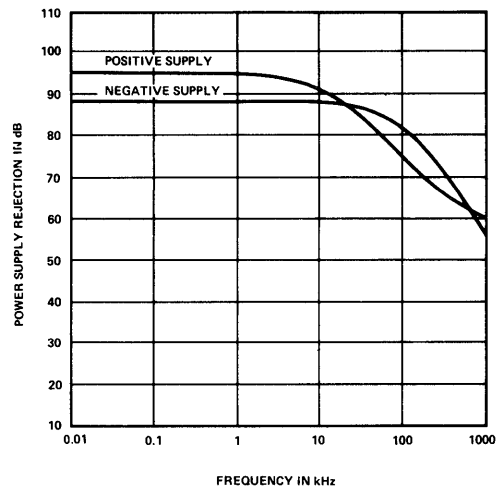

OUTPUT CURRENT VERSUS I<sub>B</sub>/V<sub>BE</sub> OF CURRENT LIMITER

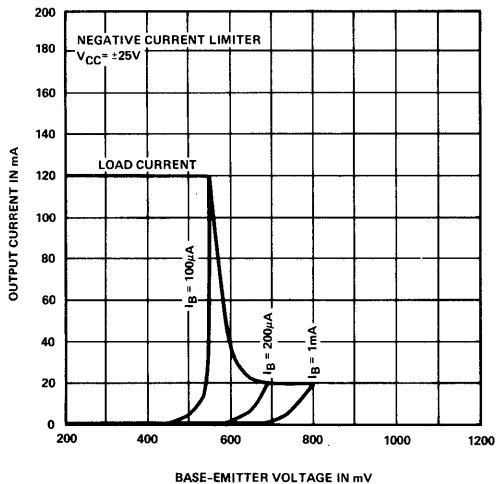

OUTPUT CURRENT VERSUS I<sub>B</sub>/V<sub>BE</sub> OF CURRENT LIMITER

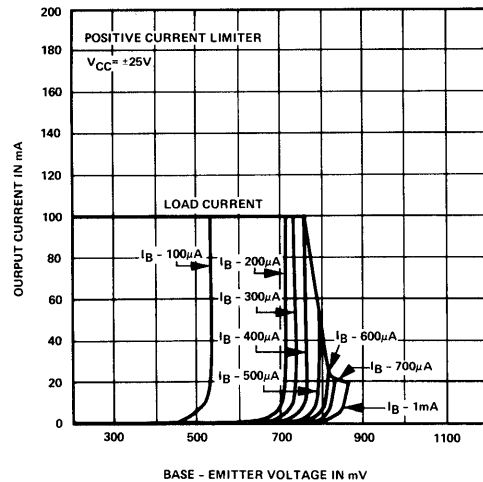



TYPICAL PERFORMANCE CHARACTERISTICS (Cont'd.)

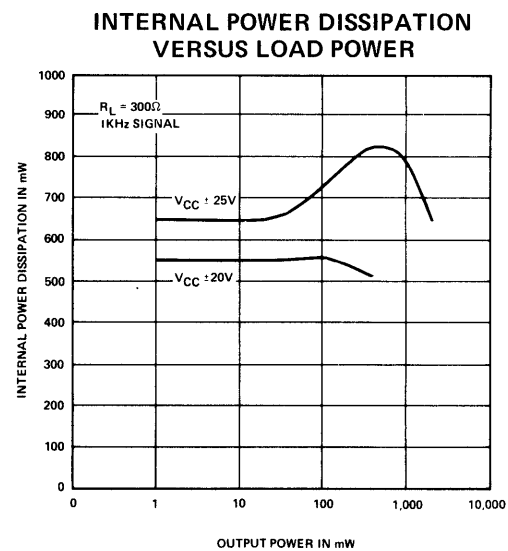
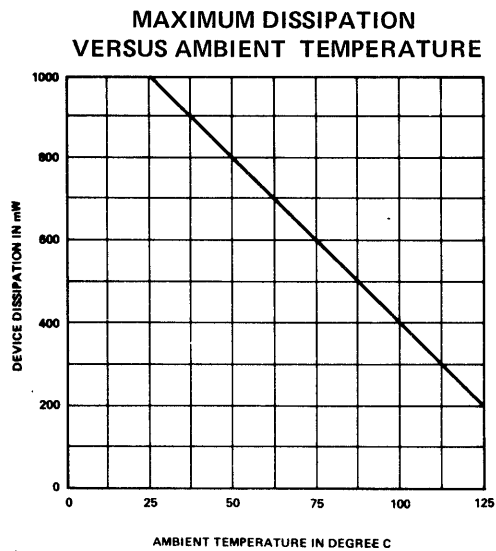
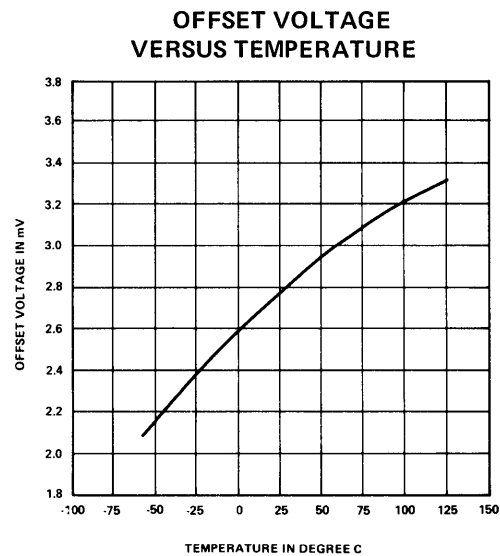
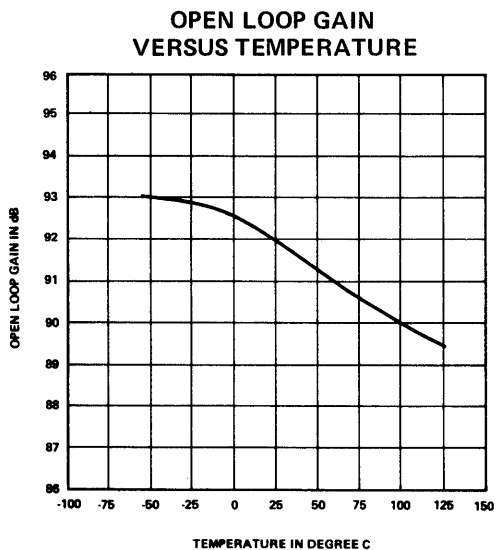
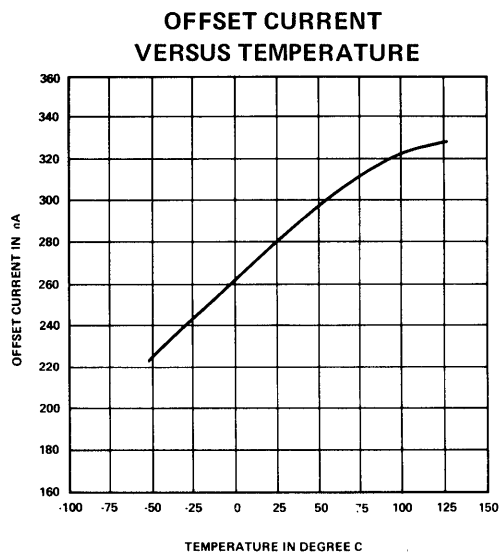
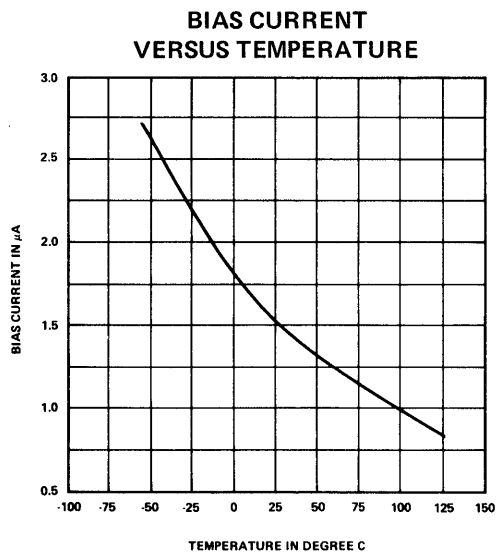

TYPICAL PERFORMANCE CHARACTERISTICS (Cont'd.)

QUIESCENT CURRENT VERSUS SUPPLY VOLTAGE

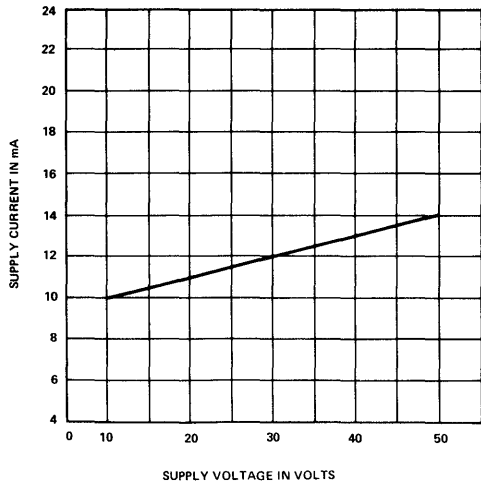

TOTAL HARMONIC DISTORTION VERSUS OUTPUT

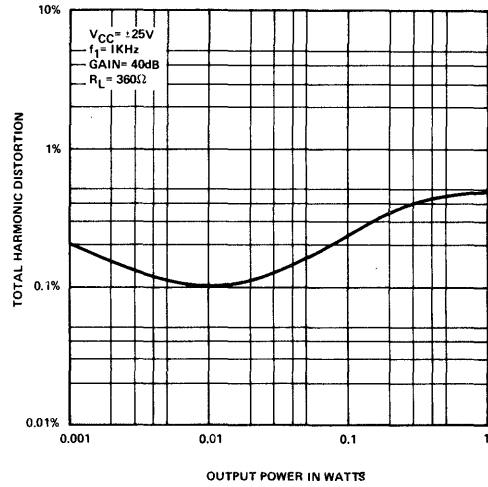

OUTPUT SATURATION VOLTAGE VERSUS LOAD

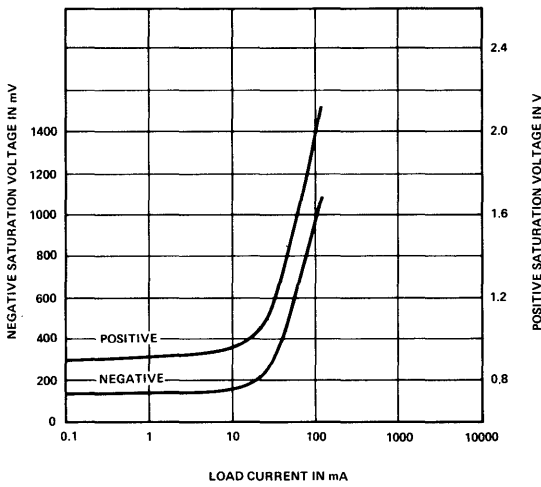

TOTAL HARMONIC DISTORTION VERSUS FREQUENCY

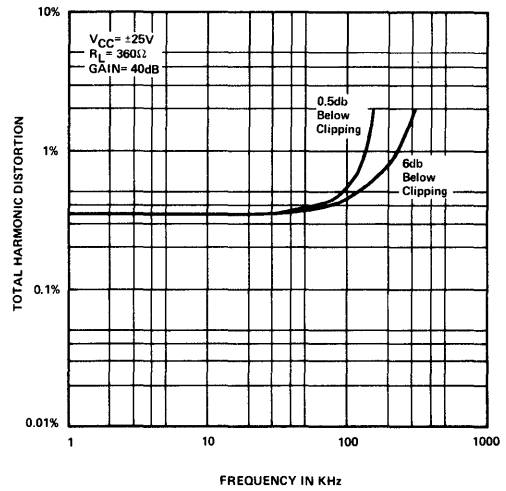

INTERMODULATION DISTORTION VERSUS LOAD

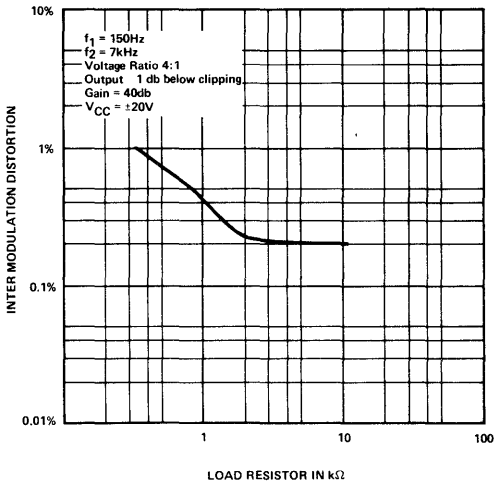

TOTAL HARMONIC DISTORTION VERSUS LOAD

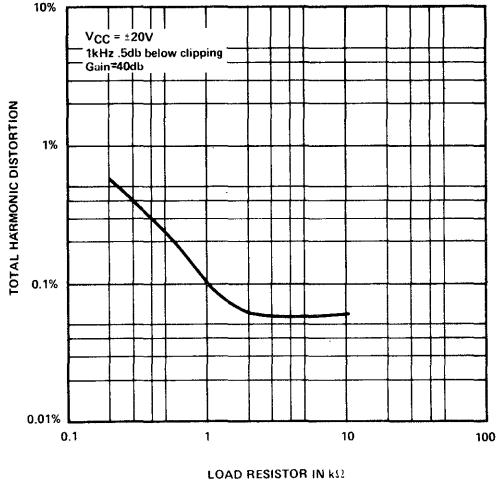

POSITIVE VOLTAGE REGULATORS

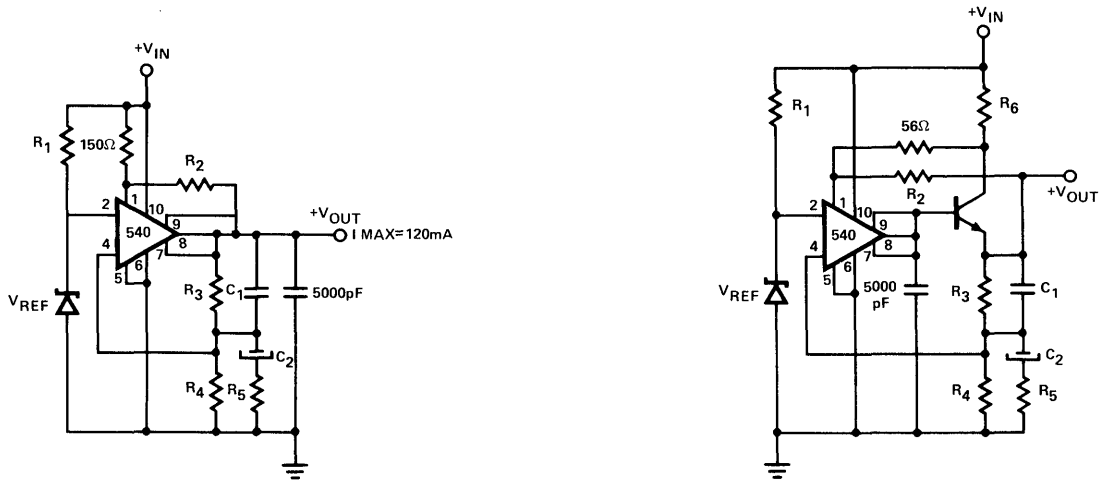

$$V_{OUT} \approx \frac{R_3 + R_4}{R_4} V_{REF}$$

$$R_1 \approx \frac{V_{IN} - V_{REF}}{I_{ZENER}}$$

$$R_2 \approx \frac{2 V_{IN} - V_{OUT}}{4mA}$$

$$R_5 \approx \frac{R_3}{100}$$

$$C_1 \approx \frac{0.2}{R_3} \mu F$$

$$C_2 \approx 10 \mu F$$

NEGATIVE VOLTAGE REGULATORS

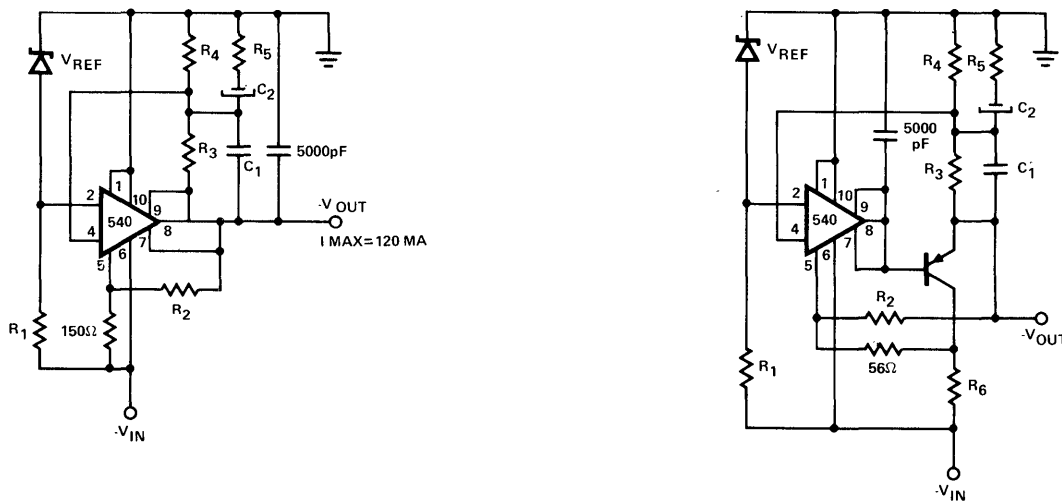

$$V_{OUT} \approx \frac{R_3 + R_4}{R_4} V_{REF}$$

$$R_1 \approx \frac{V_{IN} - V_{REF}}{I_{ZENER}}$$

$$R_2 \approx \frac{2 V_{IN} - V_{OUT}}{4mA}$$

$$R_5 \approx \frac{R_3}{100}$$

$$C_1 \approx \frac{0.2}{R_3} \mu F$$

$$C_2 \approx 10 \mu F$$

TYPICAL APPLICATIONS

POWER AMPLIFIERS

1 Watt

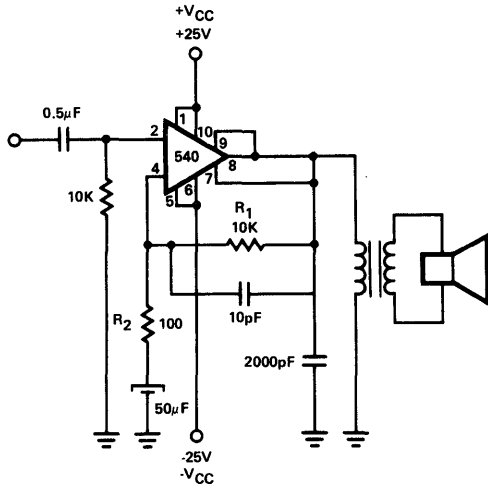

VOLTAGE GAIN  
 $A_V \approx \frac{R_1 + R_2}{R_2}$

35 Watts

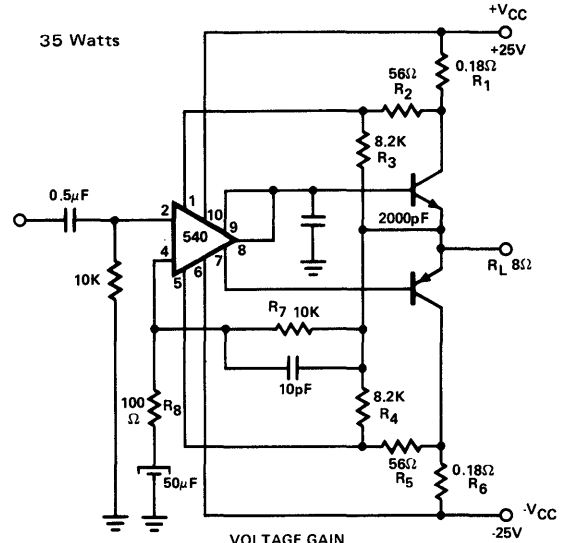

VOLTAGE GAIN  
 $A_V = \frac{R_7 + R_8}{R_8}$   
 CURRENT LIMITING  
 $R_1 = R_6 \approx \frac{650mV}{I_{peak}}$   
 POWER LIMITING  
 $R_2 = R_5 \approx 56\Omega$   
 $R_3 = R_4 \approx 3mA$

3 Watts

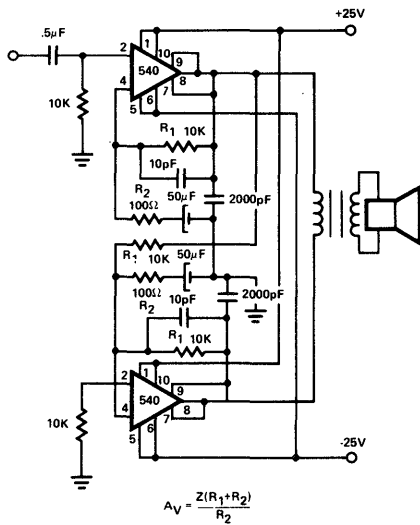

$A_V = \frac{Z(R_1 + R_2)}{R_2}$

70 Watts

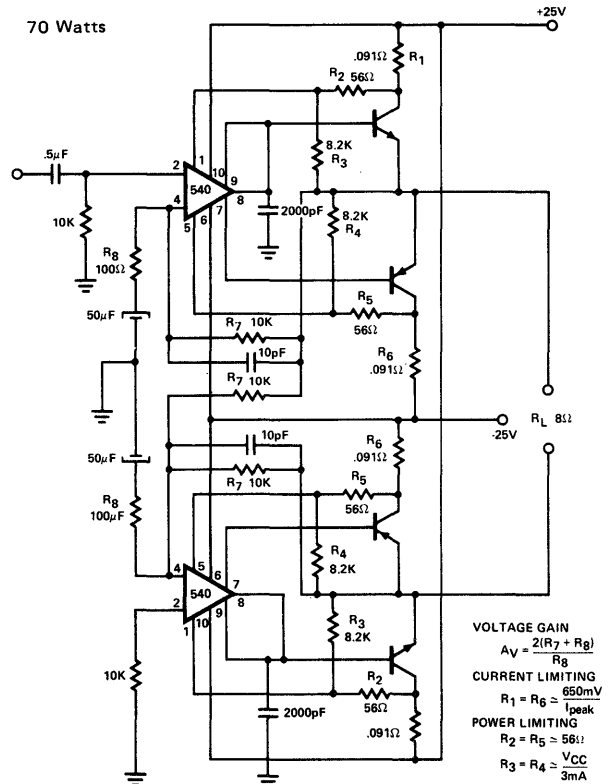

VOLTAGE GAIN  
 $A_V = \frac{2(R_7 + R_8)}{R_8}$   
 CURRENT LIMITING  
 $R_1 = R_6 \approx \frac{650mV}{I_{peak}}$   
 POWER LIMITING  
 $R_2 = R_5 \approx 56\Omega$   
 $R_3 = R_4 \approx 3mA$

35 WATT AMPLIFIER

P.C. BOARD LAYOUT (BOTTOM VIEW)

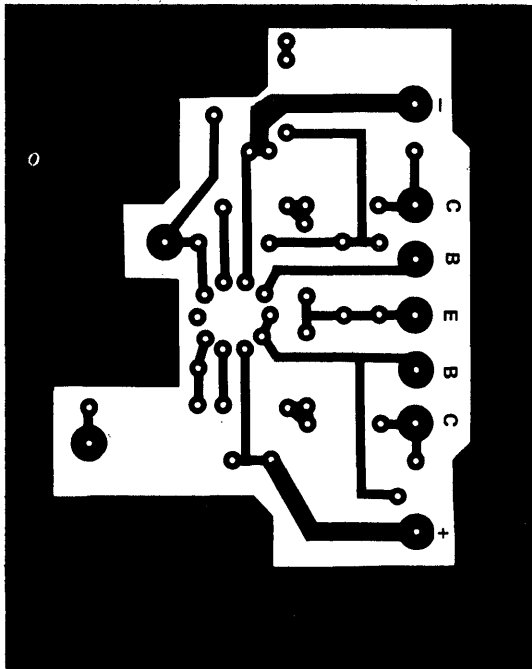

PARTS LAYOUT (TOP VIEW)

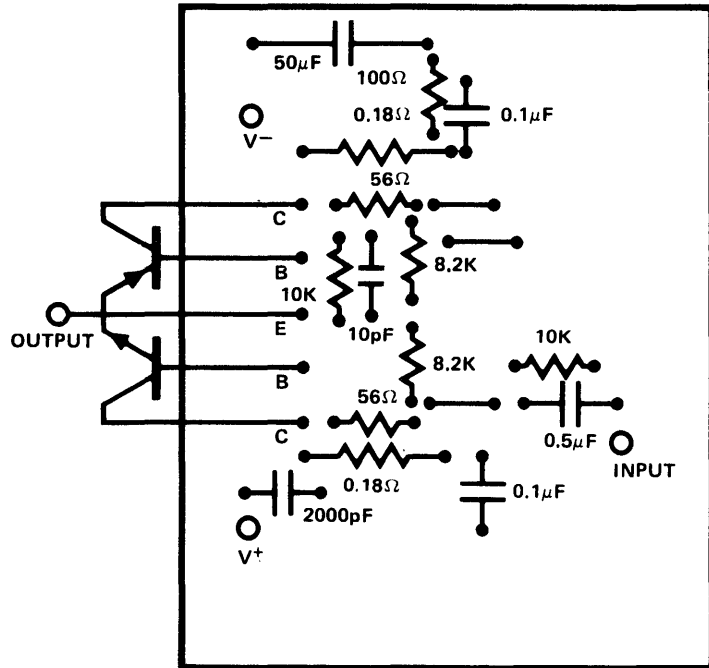

## NEW PRODUCT ADVANCED INFORMATION LINEAR INTEGRATED CIRCUITS

### FEATURES

- TIMING FROM MICROSECONDS THROUGH 1 Hr.
- CAN EITHER FREE RUN OR LATCH
- ADJUSTABLE DUTY CYCLE
- TIME DELAYS CAN BE RESET
- TEMPERATURE STABILITY 0.005% PER °C
- OPERATES FROM 4 to 15 VOLTS FOR 1% CHANGE IN TIMING
- TIMING CAN BE CHANGED 10:1 WITH CONTROL
- VOLTAGE
- OUTPUT CAN SOURCE OR SINK 100mA

### PIN CONFIGURATION

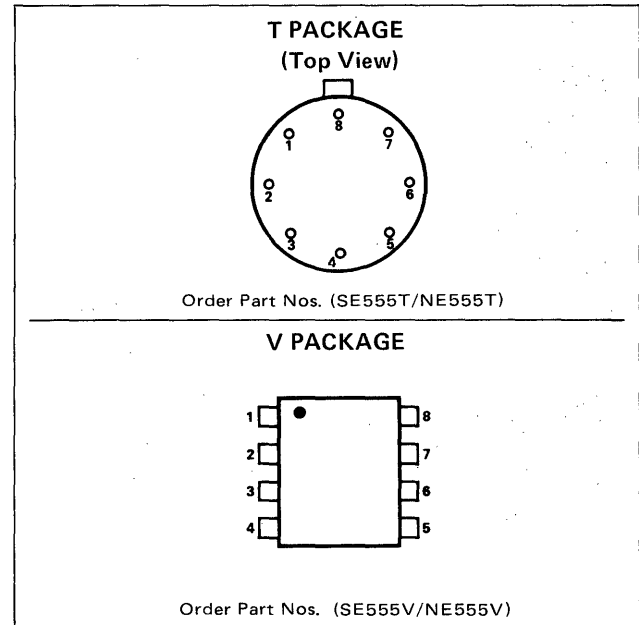

### ELECTRICAL CHARACTERISTICS (25° unless otherwise specified)

PARAMETERS	SE 555 T			NE 555 V			UNITS
	MIN.	TYP.	MAX.	MIN.	TYP.	MAX.	
Operating Temperature Range	-55		12.5	0		70	°C
Operating Supply Voltage	4.5		18	4.5		16	Volts
Operating Supply Current @5V		3			3		mA
Operating Supply Current @15V		8			8		mA
Timing Error, 10V <sup>1</sup>		0.5			1		%
Timing Error, 10V <sup>2</sup>		2			4		%
Time-Temperature Drift		30			50		ppm/°C
Time-Supply Voltage Drift		50			100		ppm/°C
Trigger Voltage		1/3			1/3		xV <sub>CC</sub>
Trigger Current		0.5			0.5		μA
Reset Voltage		0.7			0.7		Volts
Reset Current		0.1			0.1		mA
FM Input Impedance		3.3			3.3		kΩ
Bias Level		2/3			2/3		xV <sub>CC</sub>
Deviation Range		+30,-90			+30,-90		%
Output Voltage Drop (Low) @ 10mA		0.1			0.1		Volts
@ 100mA		1.8			1.8		Volts
@ 200mA		2.3			2.4		Volts
Output Voltage Drop (High) @ 100mA		1.5			1.6		Volts
@ 200mA		2.0			2.1		Volts
Rise Time		100			100		nSec
Fall Time		100			100		nSec

#### NOTES:

1. R<sub>A</sub>, R<sub>B</sub> = 1K Ohm to 100K Ohm, t = 100 μ sec.
2. R<sub>A</sub>, R<sub>B</sub> = 500 Ohm to 10M Ohm, t = 10 μ sec.
3. External Load to V<sub>CC</sub>, 2.7K Ohm.

TYPICAL CONNECTION

(Top View)

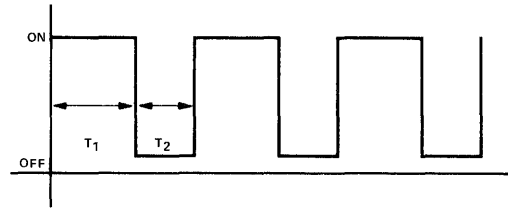
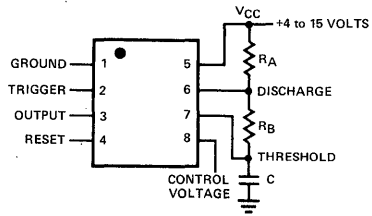

NOTES:

1. Jump 6 & 2 for free running & connect 4 to +V.
2. Ground 4 to reset timing.

3. For time delay  $T = 1.1 R_A C$  ( $R_B = 0$ )

4. For free running timing is as follows:

$$T_1 = 0.685 (R_A + R_B)C \quad T_2 = 0.685 R_B C$$

## INTRODUCTION LINEAR INTEGRATED CIRCUITS

### DESCRIPTION

The 5070, 5071, and 5072 are monolithic silicon integrated circuits that constitute a complete chroma system for color television receivers. The 5070 is a complete subcarrier regeneration system featuring a new concept of phase control applied to the oscillator circuit. The 5071 is a chroma amplifier system and the 5072 performs the demodulation function.

The 5070 utilizes the 16-lead plastic dual-in-line package; the 5071 and 5072 are supplied 14-lead plastic dual-in-line packages.

### FEATURES

- 5070
  - VOLTAGE CONTROL OSCILLATOR
  - KEYED APC & ACC DETECTORS
  - DC HUE CONTROL
  - SHUNT REGULATOR
- 5071
  - ACC CONTROLLED CHROMA AMPLIFIER
  - DC CHROMA GAIN CONTROL
  - COLOR KILLER
  - AMPLIFIER SHORT-CIRCUIT PROTECTION
- 5072
  - SYNCHRONOUS DETECTOR WITH COLOR DIFFERENCE MATRIX
  - EMITTER-FOLLOWER OUTPUT AMPLIFIERS WITH SHORT-CIRCUIT PROTECTION

### TYPICAL SCHEMATIC DIAGRAM

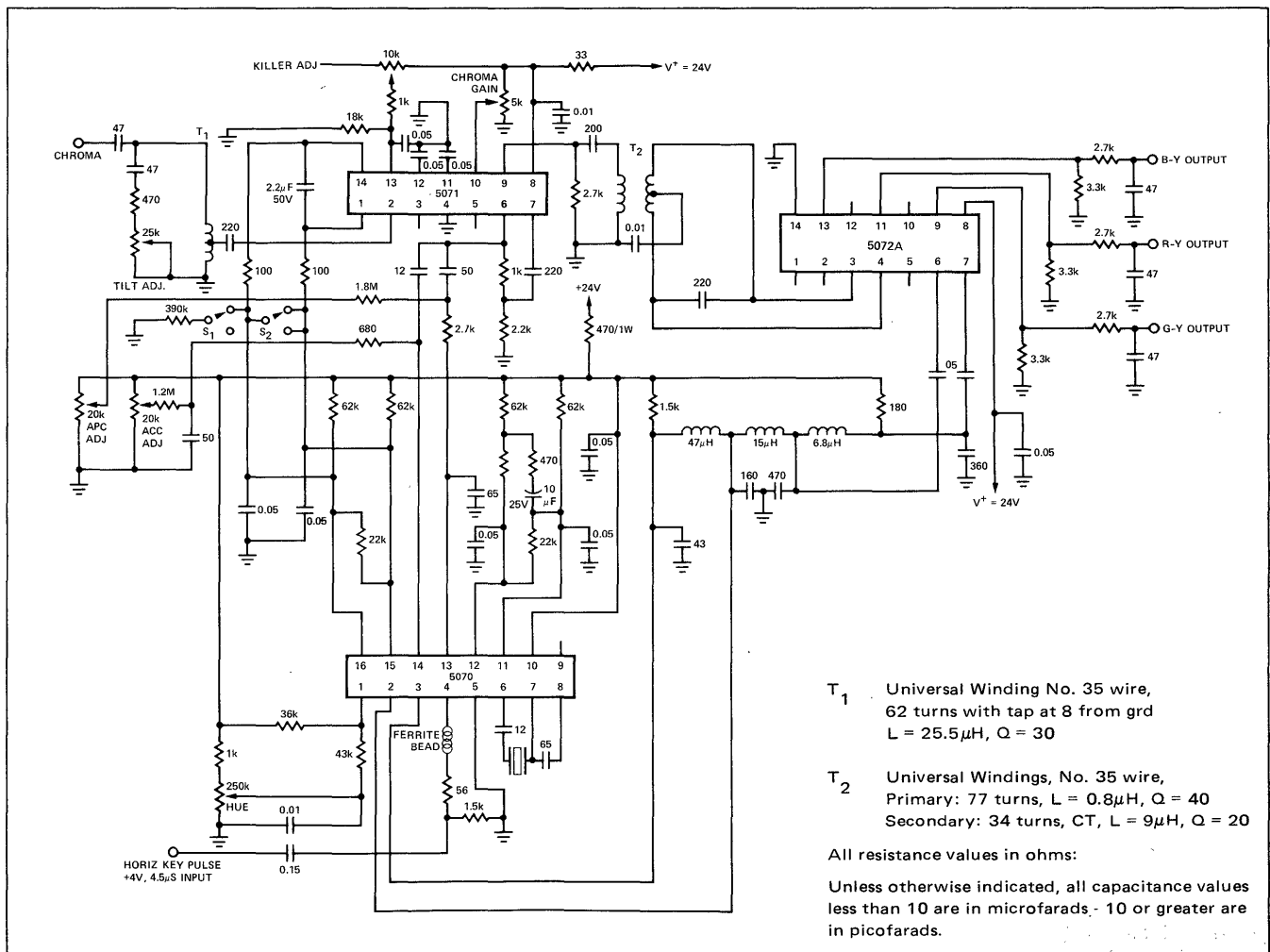



TYPICAL FUNCTIONAL DIAGRAM

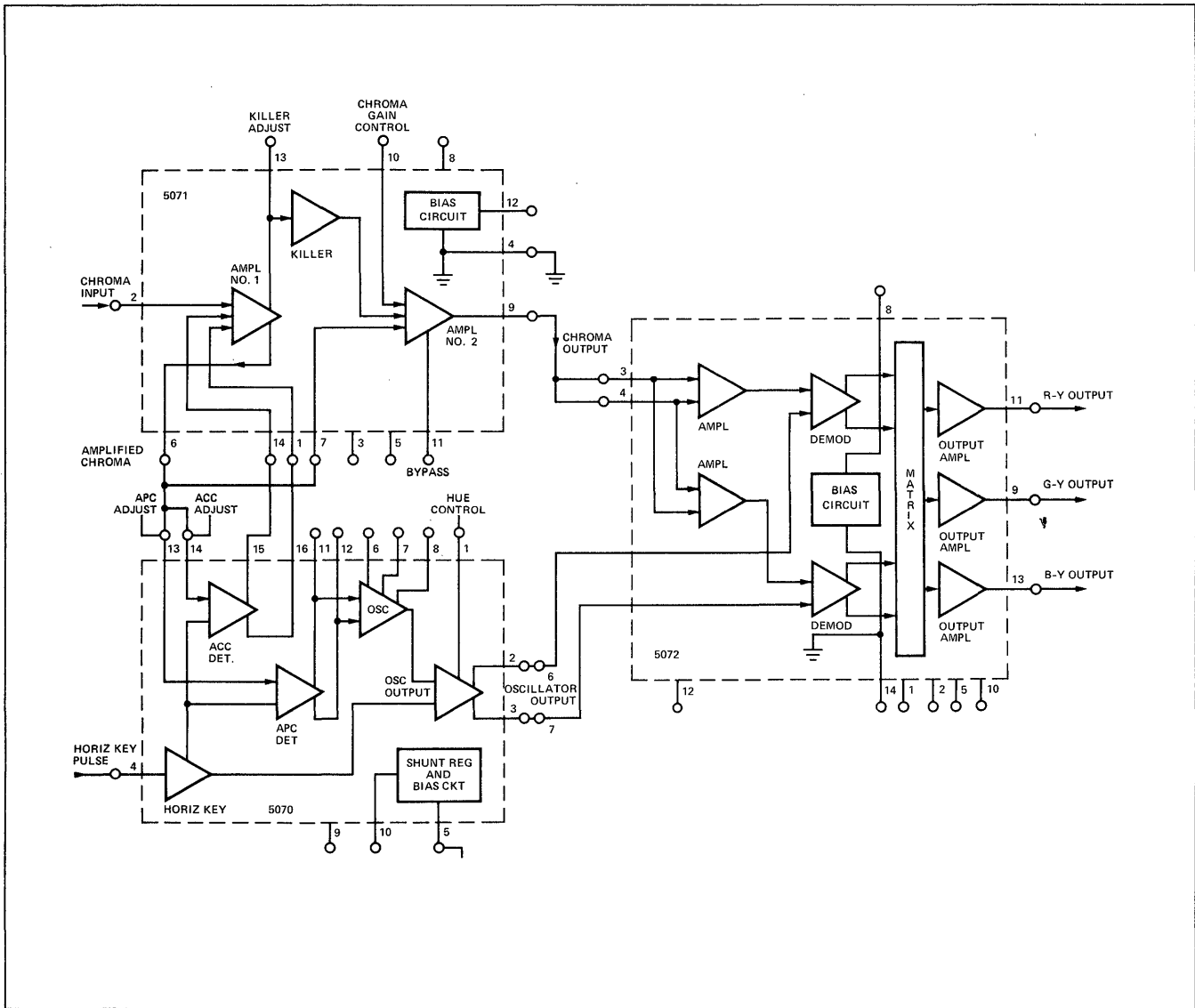

## LINEAR INTEGRATED CIRCUITS

### DESCRIPTION

The 5070 is a complete subcarrier regeneration system with automatic phase control applied to the oscillator. An amplifier chroma signal from the 5071 is applied to terminals No. 13 and No. 14, which are the automatic phase control (APC) and the automatic chroma control (ACC) inputs. APC and ACC detection is keyed by the horizontal pulse which also inhibits the oscillator output amplifier during the burst interval.

The ACC system uses a synchronous detector to develop a correction voltage at the differential output terminal Nos. 15 and 16. This control signal is applied to the input terminal Nos. 1 and 14 of the 5071. The APC system also uses a synchronous detector. The APC error voltage is internally coupled to the 3.58 MHz oscillator at balance; the phase of the signal at terminal No. 13 is in quadrature with the oscillator.

To accomplish phasing requirements, an RC phase shift network is used between the chroma input and terminal Nos. 13 and 14. The feedback loop of the oscillator is from terminal Nos. 7 and 8 back to No. 6. The same oscillator signal is available at terminal Nos. 7 and 8, but the dc output of the APC detector controls the relative signal levels at terminal Nos. 7 or 8. Because the output at terminal No. 8 is shifted in phase compared to the output at terminal No. 7, which is applied directly to the crystal circuit, control of the relative amplitudes at terminal Nos. 7 and 8 alters the phase in the feedback  $I_{cop}$ , thereby changing the frequency of the crystal oscillator. Balance adjustments of dc offsets are provided to establish an initial no-signal offset control in the ACC output, and a no-signal, on-frequency adjustment through the APC detector-amplifier circuit which controls the oscillator frequency. The oscillator output stage is differentially controlled at terminal Nos. 2 and 3 by the hue control input to terminal No. 1. The hue phase shift is accomplished by the external R, L, and C components that couple the oscillator output to the demodulator input terminals. The 5070 includes a shunt regulator to establish a 12Vdc supply.

### FEATURES

- VOLTAGE CONTROLLED OSCILLATOR
- KEYED APC & ACC DETECTORS
- DC HUE CONTROL
- SHUNT REGULATOR

### PIN CONFIGURATION

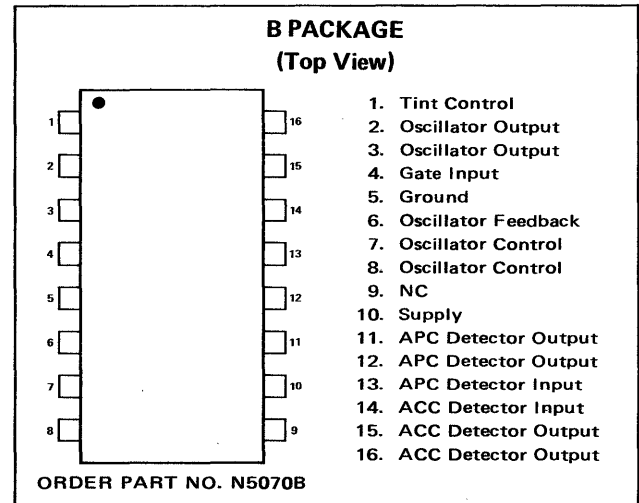

### ABSOLUTE MAXIMUM RATINGS

(Values at  $T_A = 25^\circ\text{C}$ )

DC Supply Voltage and Current

See Charts

Device Dissipation:

Up to  $T_A = +70^\circ\text{C}$

530mW

Above  $T_A = +70^\circ\text{C}$

Derate Linearly  
at 6.7 mW/ $^\circ\text{C}$

Ambient Temperature Range:

Operating

-40 to +85 $^\circ\text{C}$

Storage

-65 to +150 $^\circ\text{C}$

Lead Temperature (During Soldering):

At distance 1/32 in. (3.17 mm) from  
seating plane for 10s max

+265 $^\circ\text{C}$

### Voltage (Note 1)

TERM NO.	MIN. VOLTS	MAX. VOLTS
1	0	*
2	0	+16
3	0	+16
4	-5	Note 3
6	-	-
7	-	-
8	-	-
10	0	Note 4
11	0	Note 2
12	0	Note 2
13	0	Note 2
14	0	Note 2
15	0	+16
16	0	+16

### Current

TERM NO.	$I_j$ mA	$I_O$ mA
1	20	1
2	-	-
3	-	-
4	-	1
10	Note 4	1
11	-	-
12	-	-
13	20	1
14	20	1

### NOTES:

1. With respect to terminal No. 5 and with terminal No. 10 connected through 470 $\Omega$  to +24V.
2. Regulated voltage at terminal No. 10.
3. Controlled by max. input current.
4. Limited by dissipation.

**SCHEMATIC DIAGRAM**

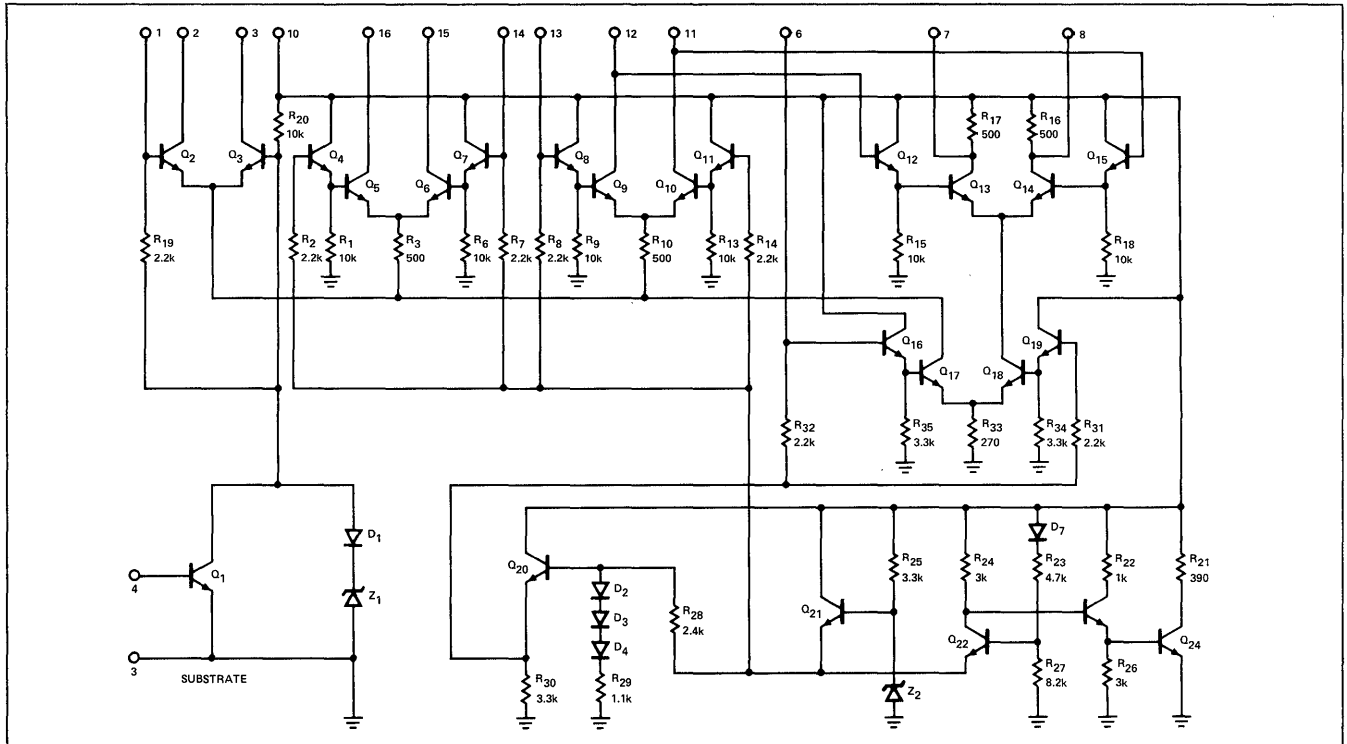

**FUNCTIONAL DIAGRAM**

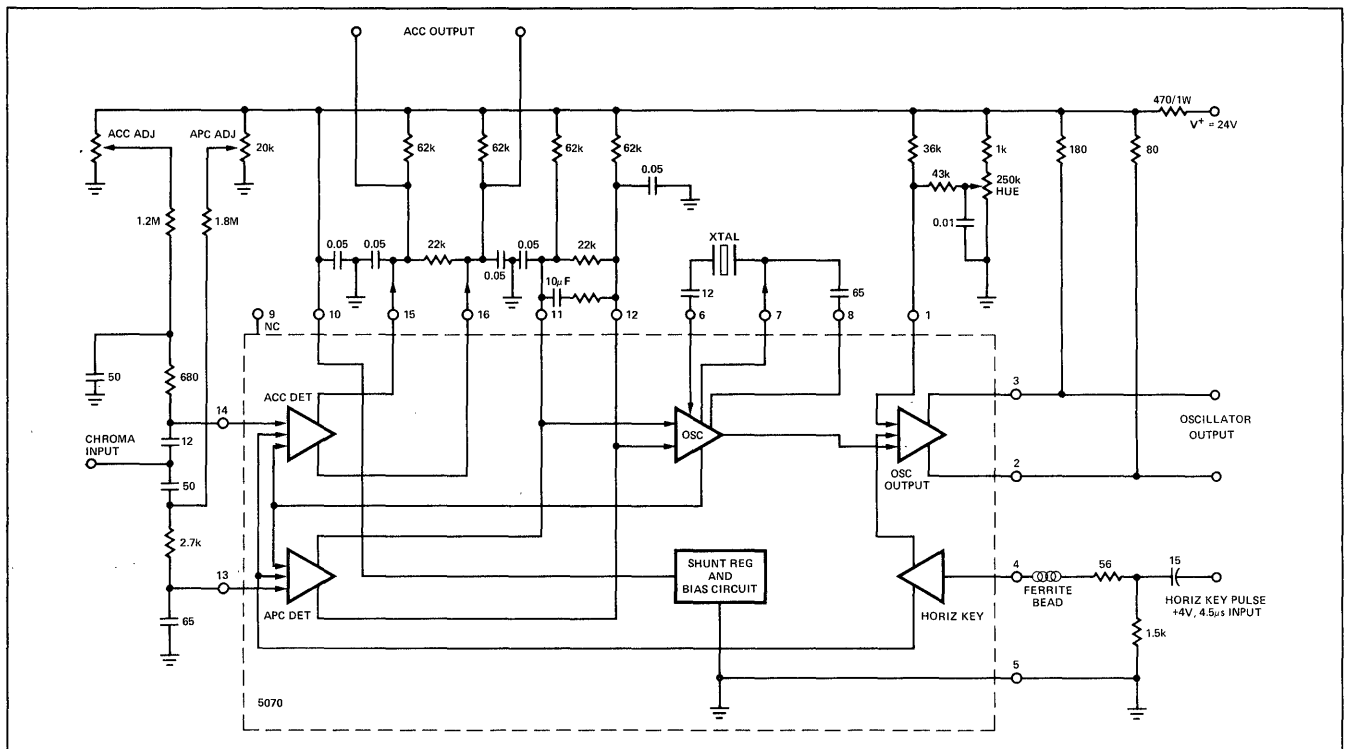

**NOTES:**

1. All resistance values are in ohms
2. Unless otherwise indicated all capacitance values less than 10 are in microfarads – 10 or greater are in picofarads.

## LINEAR INTEGRATED CIRCUITS

### DESCRIPTION

The 5071 is a combined two-stage chroma amplifier and functional control circuit. The input signal is received from the video amplifier and applied to terminal No. 2 of the input amplifier stage. The first amplifier stage is part of the ACC system and is controlled by differential adjustment from the ACC input terminal Nos. 1 and 14. The output of the 1st amplifier is directed to terminal No. 6 from where the signal may be applied to the ACC detection system of the 5070 or an equivalent circuit. The output at terminal No. 6 is also applied to terminal No. 7 which is the input to the 2nd amplifier stage. Another output of the 1st amplifier at terminal No. 13 is directed to the killer adjustment circuit.

The dc voltage level at terminal No. 13 rises as the ACC differential voltage decreases with a reduction in the burst amplitude. At a pre-set condition determined by the killer adjustment resistor the killer circuit is activated and causes the 2nd chroma amplifier stage to be cut off. The 2nd chroma amplifier stage is also gain controlled by the adjustment or dc voltage at terminal No. 10. The output of the 2nd chroma amplifier stage is available at terminal No. 9. The typical output termination circuit that is shown, provides differential chroma drive signal to the demodulator circuit. Both amplifier outputs utilize emitter-followers with short-circuit protection.

### FEATURES

- ACC CONTROLLED CHROMA AMPLIFIER
- DC CHROMA GAIN CONTROL
- COLOR KILLER
- AMPLIFIER SHORT-CIRCUIT PROTECTION

### ABSOLUTE MAXIMUM RATINGS

(Values at  $T_A = 25^\circ\text{C}$ )

DC Supply Voltage (Terminal 8 to Terminal 14) 30Vdc

Device Dissipation:  
 Up to  $T_A = +70^\circ\text{C}$  530mW  
 Above  $T_A = +70^\circ\text{C}$  Derate Linearly at 6.7 mW/ $^\circ\text{C}$

Ambient Temperature Range:  
 Operating -40 to  $+85^\circ\text{C}$   
 Storage -65 to  $+150^\circ\text{C}$

Lead Temperature (During Soldering):  
 At distance 1/32 in (3.17 mm) from seating plane for 10s max.  $+265^\circ\text{C}$

### PIN CONFIGURATION

A PACKAGE  
(Top View)

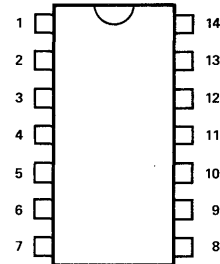

1. ACC Input
2. Chroma Input 1
3. Gain Preselect
4. Ground
5. NC
6. Chroma Output 1
7. Chroma Output 2
8. V+
9. Chroma Output 2
10. Chroma Level Control
11. Decouple
12. Decouple
13. Killer Adjust
14. ACC Input

ORDER PART NO. N5071A

### MAXIMUM RATINGS MAXIMUM VOLTAGE & CURRENT RATINGS $T_A = 25^\circ\text{C}$

Voltage (Note 1) Current

TERM NO.	MIN. VOLTS	MAX. VOLTS	TERM NO.	$I_I$ mA	$I_O$ mA
1	-5	+15	1	5	1.0
2	-5	+5	2	5	1.0
6	0	+24	6	1.0	20
7	-5	+5	7	5	1.0
8	0	+30	9	1.0	20
9	0	+24	12	1.0	5
10	0	+24	14	5	1.0
11	0	+24			
12	0	+20			
13	0	+20			
14	-5	+15			

#### NOTES:

1. With reference to terminal No. 4 and with +24V on terminal No. 8 except for the rating given for terminal No. 8.

**SIGNETICS ■ 5071 – CHROMA AMPLIFIER**

**ELECTRICAL CHARACTERISTICS** ( $T_A = 25^\circ\text{C}$  and  $V^+ = +24\text{V}$ )

PARAMETERS	TEST CONDITIONS	LIMITS			UNITS
		MIN	TYP	MAX	
<b>STATIC CHARACTERISTICS</b>					
Voltages					
Bias Reference Terminal	$S_1$ Open, $S_2$ Open		17.3		V
Ampl No. 1 Chroma Input	$S_1$ Open, $S_2$ Open		1.75		V
Ampl No. 1 Chroma Output Balanced	$S_1$ Open, $S_2$ Open		20		V
Unbalanced	$S_1$ Open, $S_2$ Closed		13.5		V
Ampl No. 2 Chroma Input	$S_1$ Open, $S_2$ Open		1.5		V
Ampl No. 2 Chroma Output	$S_1$ Closed, $S_2$ Open		20.6		V
Supply Current	$S_1$ Open, $S_2$ Open	17		31	mA
<b>DYNAMIC CHARACTERISTICS</b>					
Amplifier No. 1 Voltage Gain	$E_g = 30$ mVrms Measure V6	14			dB
Amplifier No. 2 Voltage Gain	$V_g = 10$ Vrms		14		dB
Max. Chroma Output Voltage			2		Vrms
10% Chroma Gain Control Reference Voltage	$E_g = 50$ mVrms, adjust Chroma Gain Control to Change $V_g$ to 10% of Maximum Chroma Output		20.2		V
Output Voltage Killer Off	$S_1$ in Position 2 $E_g = 50$ mVrms, adjust "Killer Adjust" for an abrupt decrease in $V_g$			12	mV rms
Output Voltage, Chroma Off	$E_g = 50$ Vrms, adjust Chroms control to min. Chroma Output			12	mV rms
Bandwidth					
Amplifier No. 1			12		MHz
Amplifier No. 2			30		MHz
Ampl. No. 1 Input Impedance			2		k $\Omega$
Ampl. No. 1 Output Impedance			4		pF
Ampl. No. 2 Input Impedance			35		$\Omega$
Ampl. No. 2 Output Impedance			2.1		k $\Omega$
			3.5		pF
			85		$\Omega$

**AMPLIFIER DIAGRAM**

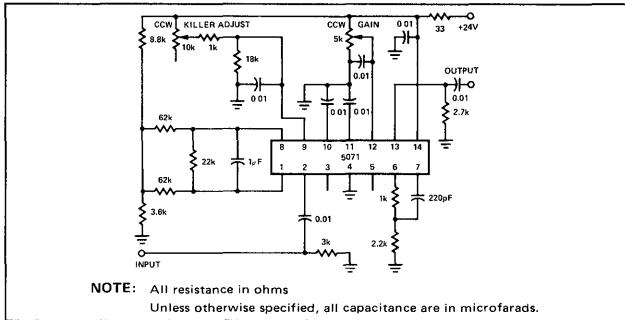

**FUNCTIONAL DIAGRAM**

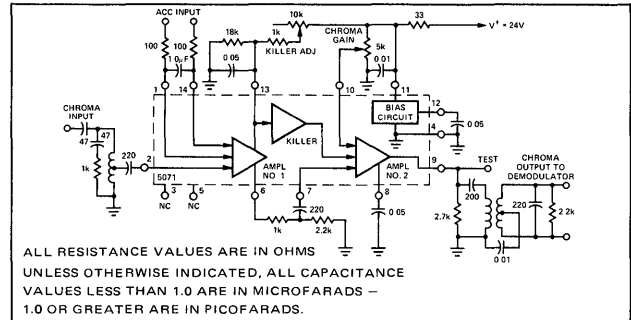

**SCHEMATIC DIAGRAM**

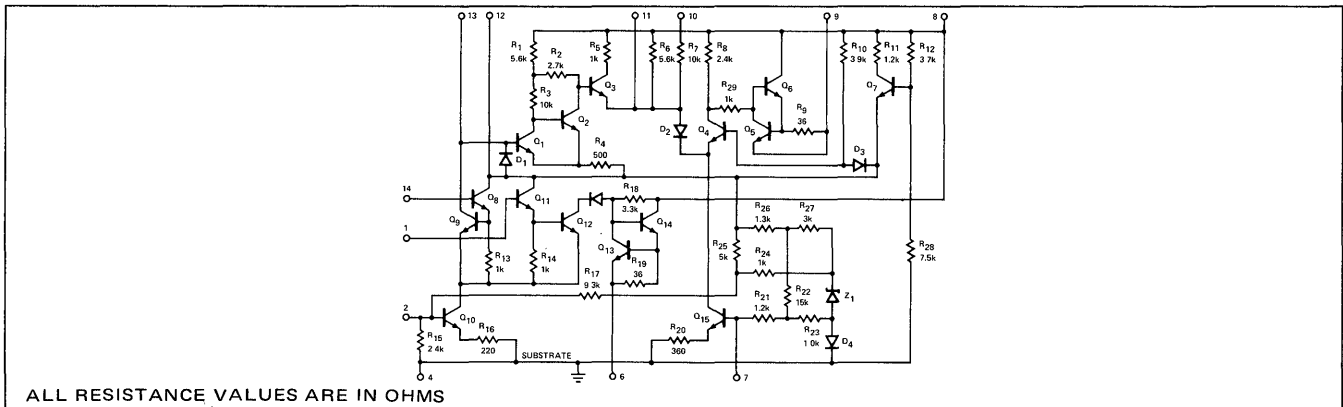

## LINEAR INTEGRATED CIRCUITS

### DESCRIPTION

The 5072 has two sets of synchronous detectors with matrix circuits to achieve the R-Y, G-Y, and B-Y color difference output signals. The chroma input signal is applied to terminal Nos. 3 and 4 while the oscillator injection signal is applied to terminal Nos. 6 and 7. The color difference signals, after matrix, have a fixed relationship of amplitude and phase nominally equal dc voltage levels. The outputs of the 5072 are suitable to driving high level color difference or R, G, B output amplifiers. Emitter-follower output stages used to drive the high level color amplifiers have short-circuit protection.

### FEATURES

- SYNCHRONOUS DETECTOR WITH COLOR DIFFERENCE MATRIX
- EMITTER-FOLLOWER OUTPUT AMPLIFIERS WITH SHORT-CIRCUIT PROTECTION

### ABSOLUTE MAXIMUM RATINGS

(Values at  $T_A = 25^\circ\text{C}$ )

DC Supply Voltage (Terminal 8 to Terminal 14)	27V
Reference Input Voltage	5V <sub>p-p</sub>
Chroma Input Voltage	5V <sub>p-p</sub>
Device Dissipation:	530mW
Up to $T_A = +70^\circ\text{C}$	Derate Linearly
Above $T_A = +70^\circ\text{C}$	at 6.7 mW/ $^\circ\text{C}$
Ambient Temperature Range:	
Operating	-40 to +85 $^\circ\text{C}$
Storage	-65 to +150 $^\circ\text{C}$
Lead Temperature (During Soldering):	
At distance 1/32 in (3.17 mm) from seating plane for 10s max.	+165 $^\circ\text{C}$

### PIN CONFIGURATION

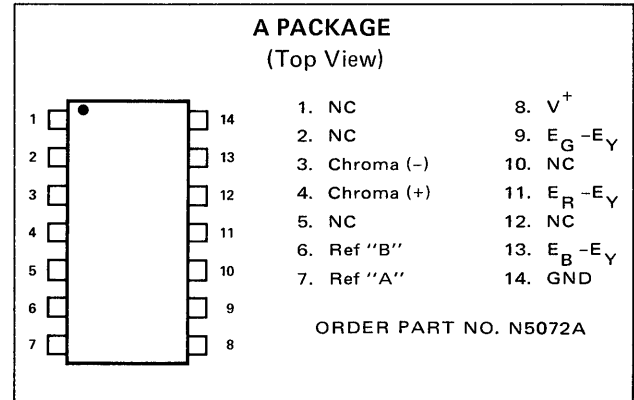

### MAXIMUM VOLTAGE & CURRENT RATINGS

$T_A = 25^\circ\text{C}$  VOLTAGE (Note 1) CURRENT

Terminal No.	MIN. VOLTS	MAX. VOLTS	Terminal No.	I <sub>I</sub> mA	I <sub>O</sub> mA
3	0	+5	3	-	-
4	0	+5	4	-	-
6	0	+12	6	-	-
7	0	+12	7	-	-
8	0	+27	8	-	-
9	0	-20	9	10	20
11	0	+20	11	10	20
13	0	+20	13	10	20

### NOTE:

1. With reference to terminal No. 14 and with the voltage between terminal No. 8 and terminal No. 14 at +24 V except as given in rating for terminal No. 8.

### SCHEMATIC DIAGRAM

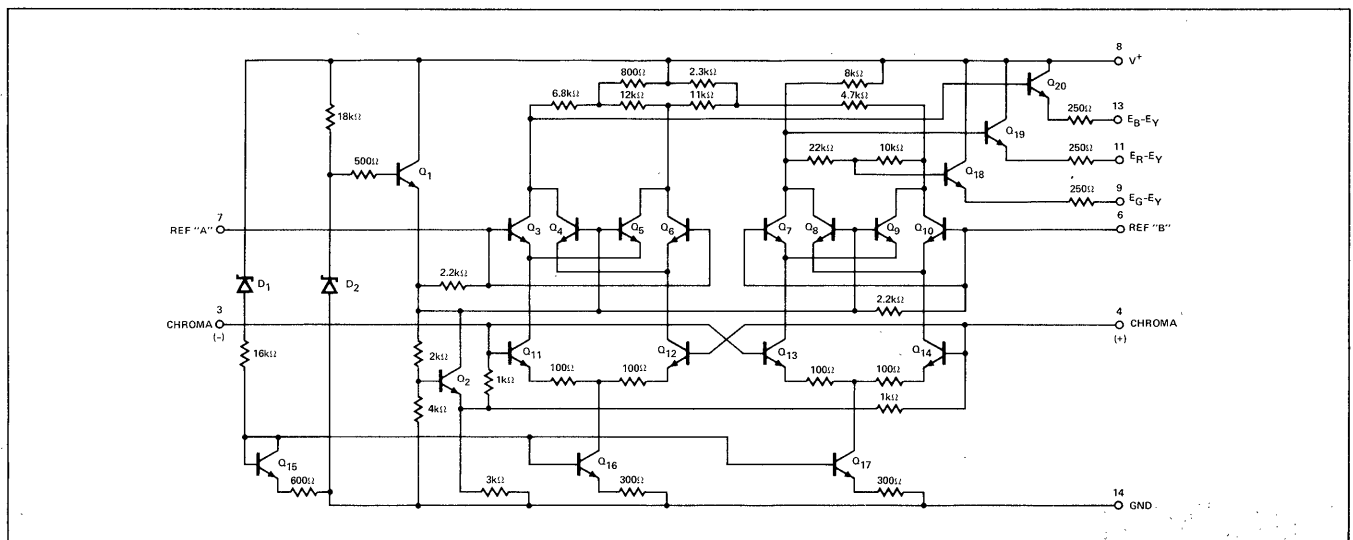

**SIGNETICS ■ 5072 – CHROMA DEMODULATOR**

**ELECTRICAL CHARACTERISTICS** ( $T_A = 25^\circ\text{C}$  and  $V^+ = +24\text{V}$  unless otherwise specified)

PARAMETERS	TEST CONDITIONS	LIMITS			UNITS
		MIN	TYP	MAX	
<b>STATIC CHARACTERISTICS</b>					
Supply Current With Output Loads	$S_1$ Closed	16.5		26.5	mA
With No Output Loads	$S_1$ Open		9		mA
G-Y, R-Y, B-Y Outputs	$S_1$ Closed	13.2	14.7	15.8	V
Chroma Inputs	$S_1$ Open		3.3		V
Reference Subcarrier	$S_1$ Open		6.2		V
<b>DYNAMIC CHARACTERISTICS</b>					
Demodulator Unbalance	$V_3 = V_4 = 0$			0.8	Vp-p
Maximum Color Difference Output Voltage	$V_3 = V_4 = 0.6 \text{ Vp-p}$	8.0			Vp-p
		5.5			Vp-p
		1.2			Vp-p
Chroma Input Sensitivity	Adjust $e_c$ for 5.0 Vp-o @ term		0.2	0.35	Vp-p
Relative R-Y Output	No. 13 (B-Y)	3.5		4.2	Vp-p
Relative G-Y Output		0.75		1.25	Vp-p
$V_{DC}$ Difference Between any two Output Terminals	$e_c = 0$			0.6	V
Input Impedance Reference Subcarrier Inputs			1.7		k $\Omega$
			6		pF
Input Impedance at Chroma Inputs			0.95		k $\Omega$
			6		pF
Output Resistance			180		$\Omega$

**FUNCTIONAL DIAGRAM**

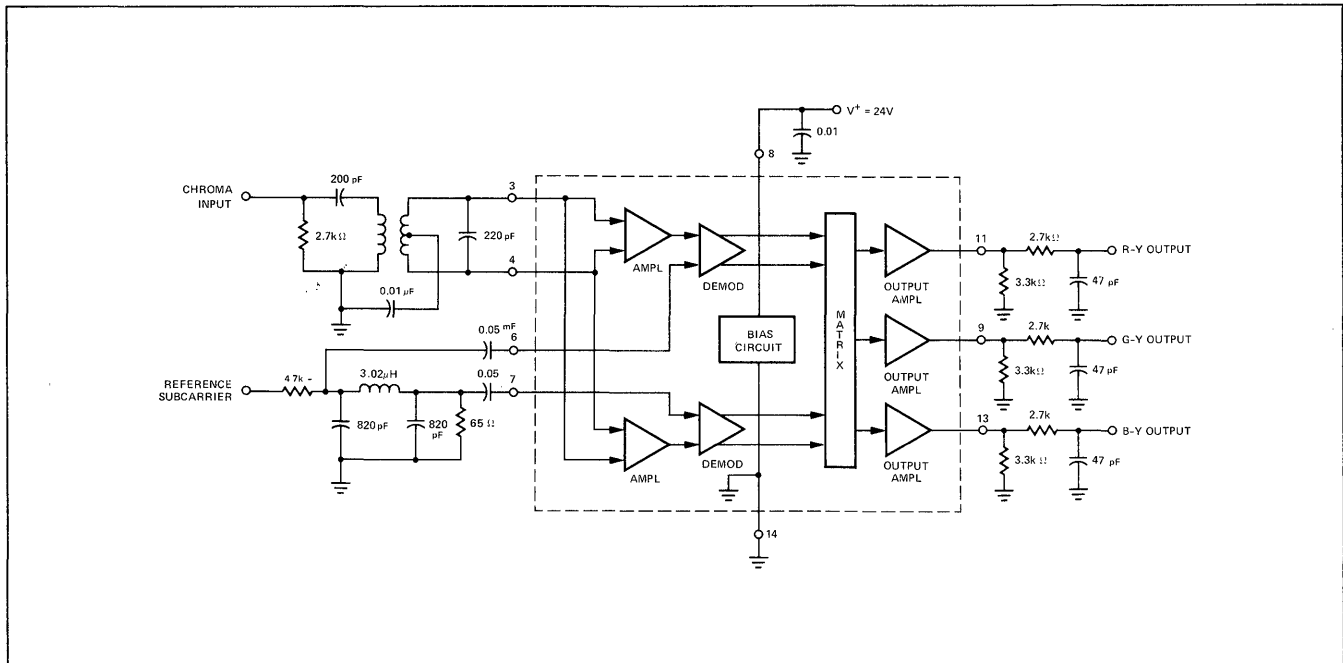

## LINEAR INTEGRATED CIRCUITS

### DESCRIPTION

A unique method of FM detection by a new technique of linear gating is featured in the ULN2111 monolithic integrated circuit. This linear device comprises a three-stage limiter and a balanced product detector. Applications for the ULN2111 device include TV sound channels, FM receivers, automatic frequency control systems, and communication receivers.

Other applications for the ULN2111 device are in the more sophisticated circuitry in telemetry receivers, automatic control systems, and servo amplifiers.

An outstanding feature of the ULN2111 is that only one, simple, low-cost, single winding coil is required for tuning. Consequently, only one screwdriver adjustment is required to tune a detector employing the ULN2111. The frequency range of the ULN2111 extends from 5 kHz to 50 MHz.

Outputs of 0.6V with a total distortion of less than 1% and a limiting threshold voltage of  $400\mu V_{rms}$  are typical.

### FEATURES

- HIGH SENSITIVITY – INPUT LIMITING VOLTAGE AT 4.5MHz =  $400\mu V$
- HIGH IF VOLTAGE GAIN – 60dB
- SIMPLIFIED TUNING – ONE RLC PHASE SHIFT NETWORK
- HIGH STABILITY
- LOW DISTORTION – 1.0%
- WIDE FREQUENCY CAPABILITY – 5kHz to 50MHz

### BLOCK DIAGRAM

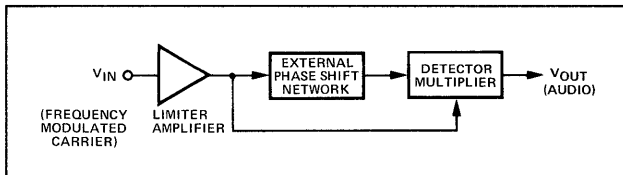

### BASIC CIRCUIT SCHEMATIC

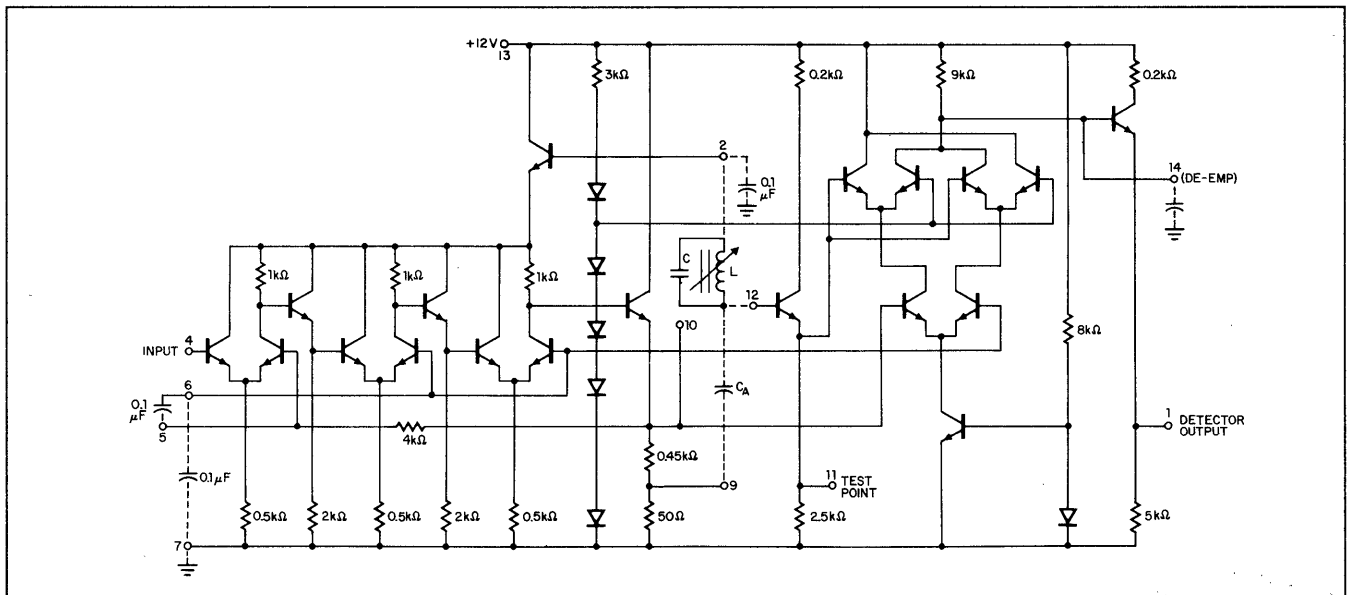

### PIN CONFIGURATION

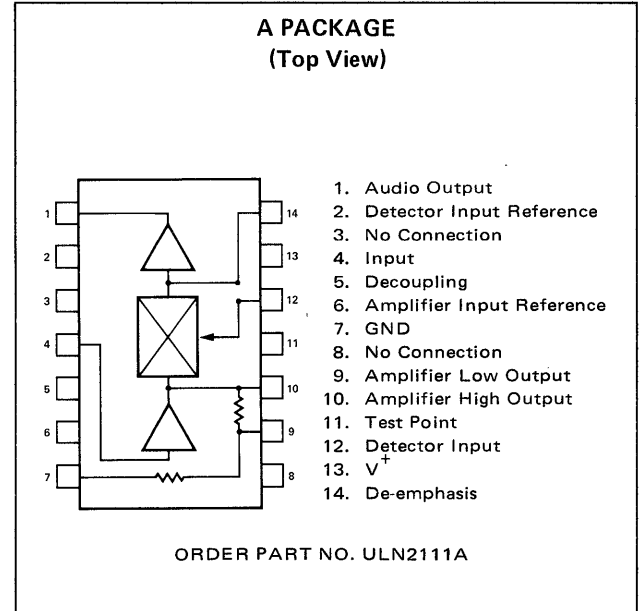

### ABSOLUTE MAXIMUM RATINGS

Input Voltage (Pin 4)	+3.5V
Output Voltage	+15V
Supply Voltage (V <sup>+</sup> )	+15V
Junction Temperature	+150°C
Storage Temperature	-65°C to +150°C
Operating Temperature	0°C to +85°C
Thermal Resistance $\theta_{J-A}$ , Junction to Ambient	0.15°C/mW
Power Dissipation	300mW



**SIGNETICS ■ ULN2111 – FM DETECTOR AND LIMITER**

**ELECTRICAL CHARACTERISTICS:** Standard Conditions:  $V_{CC} = +12V \pm 10\%$ ,  $T_A = 25^\circ C$

CHARACTERISTICS	SYMBOL	LIMITS				TEST CONDITIONS	TEST FIGURE	NOTES
		MIN	TYP	MAX	UNITS			
Supply Current	$I_{CC}$	12.0	17	22	mA		Pin 13	
Amplifier Input Reference	$V_{bias}$		1.45		V	Internally derived	6	
Detector Input Reference	$V_{bias}$		3.65		V	Internally derived	2	
Amplifier High Output Level	$V_{oh}$		1.45		V		10	
Amplifier Low Output Level	$V_{ol}$		0.145		V		9	
Detector Output Level	$V_o$	4.3	5.0	5.7	V		1	
Amplifier Input Resistance	$R_{in}$		5.0		K $\Omega$		4	
Amplifier Input Capacitance	$C_{in}$		11		pF		4	
Detector Injection Input Resistance	$R_{in}$		70		K $\Omega$		12	
Detector Injection Input Capacitance	$C_{in}$		2.7		pF		12	
Amplifier High Output Resistance	$R_{out}$		60		$\Omega$		10	
Detector Output Resistance	$R_{out}$		200		$\Omega$		1	
De-Emphasis Resistance	$R_{de}$		9		K $\Omega$		14	
<b>FM Detection for Television Applications:</b>						Detector injection voltage = $60mV_{rms}$ , $f_o = 4.5$ MHz, F deviation = 25 kHz, Peak separation = 150 kHz, FM modulating frequency = 400 Hz, Amplifier source resistance = $50\Omega$ .		
Amplifier Voltage Gain	$V_g$	55	58		dB	$V_{in} \leq 0.3mV_{rms}$ $V_{cc} = 12V \pm 5\%$	10	1
Amplifier Output Voltage	$V_{oa}$		1.45		$V_{pp}$	$V_{in} = 10mV_{rms}$	10	1
Input Limiting Threshold	$V_{th}$		400	800	$\mu V_{rms}$		4	2 1
Recovered Audio Output	$A_{vo}$	0.5	0.6		$V_{rms}$		1	2
Output Distortion	$T_{hd}$		1.5		%	100% FM Modulation	1	2
AM Suppression	AMR	40	46		dB	$V_{in} = 10mV_{rms}$	1	3 2
<b>FM Detection for 10.7 MHz Applications:</b>						Detector injection voltage = $60mV_{rms}$ , $f_o = 10.7$ MHz, F deviation = 75 kHz, Peak separation = 550 kHz, FM modulating frequency = 400 Hz, Amplifier source resistance = $50\Omega$ .		
Amplifier Voltage Gain	$V_g$		53		dB	$V_{in} \leq 0.3mV_{rms}$ $V_{cc} = 12V \pm 5\%$	10	1
Amplifier Output Voltage	$V_{oa}$		1.45		$V_{pp}$	$V_{in} = 10mV_{rms}$	10	1
Input Limiting Threshold	$V_{th}$		500		$\mu V_{rms}$		4	2 1
Recovered Audio Output	$A_{vo}$		0.45		$V_{rms}$		1	2
Output Distortion	$T_{hd}$		1.0		%	100% FM modulation	1	2
AM Suppression	AMR		40		dB	$V_{in} = 10mV_{rms}$	1	3 2

**NOTES**

1. The limiting threshold voltage is the FM input voltage  $V_i$ , expressed in rms volts, for a recovered  $V_{out}$  which is 3dB less than the recovered  $V_{out}$  at a  $V_i$  of  $200mV_{rms}$ .
2. The Amplitude Modulation Rejection in decibels, often abbreviated AMR, is given by the following formula:

$$AMR = 20 \log \frac{V_{out} \text{ for } 100\% \text{ FM modulated } V_i}{V_{out} \text{ for a } 30\% \text{ AM } V_i}$$

USEAGE INFORMATION

1. FM DETECTION.

- a. Tuning. Apply FM modulated signal through DC decoupling network to pin 4,  $V_{in} = 5mV_{rms}$ . Tune for maximum recovered audio at pin 1 or maximum RF voltage at pin 11.
- b. General
  - (1) A DC path less than  $100\Omega$  shall be provided between pins 2 and 12. No other biasing provisions are required.
  - (2) A DC path less than  $300\Omega$  should be provided between pins 4 and 6. No other biasing provisions are required.
  - (3) The maximum AC load current can be increased by adding an external resistor between pins 1 and 7. The minimum value for this resistor is  $800\Omega$ , giving a maximum load current of  $4mA_{rms}$ .

2. EXTERNAL DECOUPLING AND MOUNTING CONSIDERATIONS.

- a. All decoupling capacitors should be ceramic type with minimum residual inductance at the operating frequency.
- b. Decoupling capacitor leads at pins 5, 6, and 12 should be as short as possible.
- c. Connections from pin 4 should be as far removed as possible from connections at pins 9, 10, and 12.
- d. The power supply pin 13 should be decoupled with a  $0.1\mu F$  ceramic capacitor, keeping the leads as short as possible.
- e. When using a large internal impedance power supply (voltage dropping resistor), decouple pin 13 for the lowest audio demodulation frequency.
- f. Keep appropriate distances between the input coil and any other coil in the phase shift network for the voltage gain between these points is high (40 to 60dB).

TEST CIRCUITS

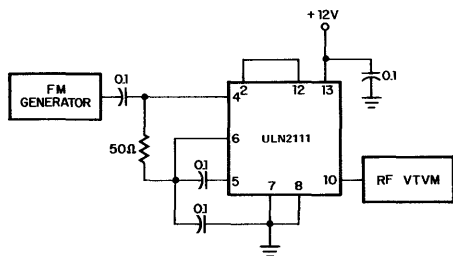

FIGURE 1

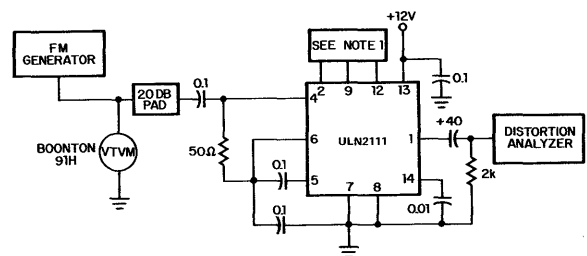

FIGURE 2

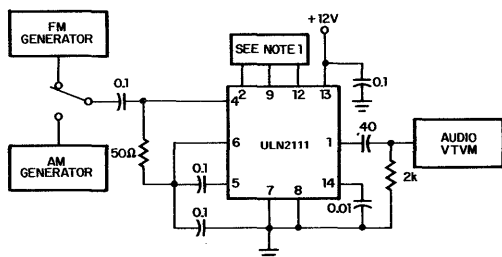
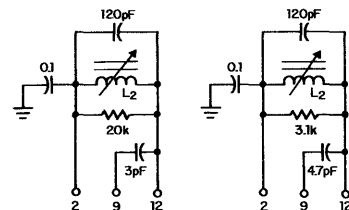

FIGURE 3



PHASE SHIFT NETWORK  
(a) FOR 4.5 MHz  
(b) FOR 10.7 MHz

FIGURE 4

NOTES: 1. Phase shift network is specified in Figure 4. 2. All capacitors in microfarads unless otherwise noted.

APPLICATIONS

TYPICAL CIRCUIT REQUIREMENTS FOR FM DETECTION

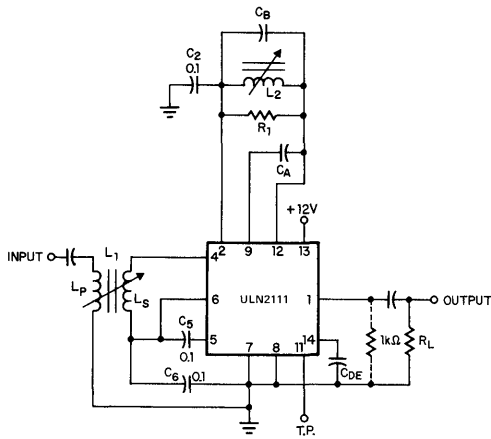

	Component Value		Notes
	TV (4.5 MHz)	FM (10.7 MHz)	
L <sub>2</sub> Inductance	7 - 14μH	1.5 - 3μH	1
L <sub>2</sub> Nom. Unloaded Q	50	50	
L <sub>2</sub> Nom. DC Resistance	50Ω	50Ω	
C <sub>A</sub>	3.0pF	4.7pF	2
C <sub>B</sub>	120pF	120pF	
R <sub>1</sub>	20kΩ	3.1kΩ	
C <sub>5</sub> and C <sub>6</sub>	30	20	
C <sub>2</sub>	0.1μF	0.1μF	
C <sub>de</sub>	0.01μF	0.01μF	

NOTES:

1. Suggested coil source: 1.5 - 3μH Miller 9050, 7 - 14μH Miller 9052.
2. Use NPO type capacitor.

Figure 5

TYPICAL DRIVING CAPABILITIES at f<sub>o</sub> = 4.5MHz

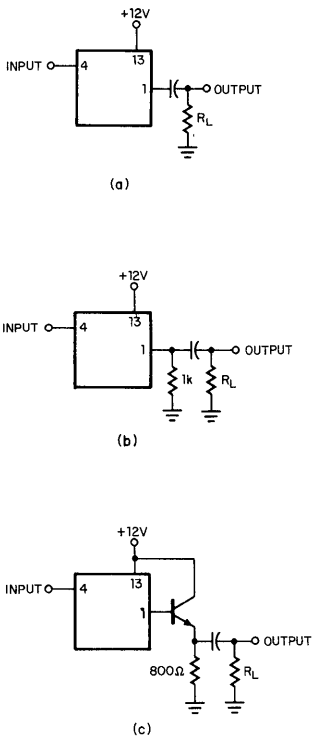

V <sub>o</sub> (mV <sub>rms</sub> )				
Figure	R <sub>L</sub> (Ω)	Δf = 7.5 kHz	Δf = 25 kHz	Remarks
A	2000	220	650	No Clipping
B	200	130	400	No Clipping
C	200	220	650	Clipping at V <sub>o</sub> = 500mV <sub>rms</sub>

Figure 6

**AMPLIFIER GAIN AS A FUNCTION OF AMBIENT TEMPERATURE**

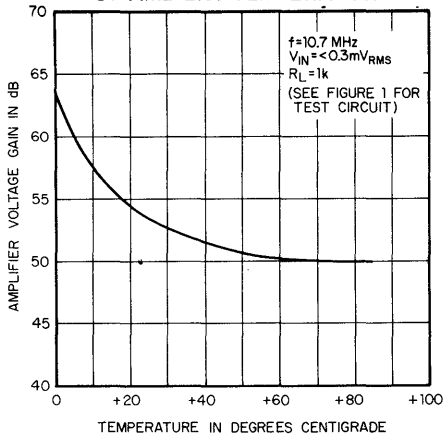

**SLOPE OF FM TRANSFER CHARACTERISTICS AS A FUNCTION OF AMBIENT TEMPERATURE**

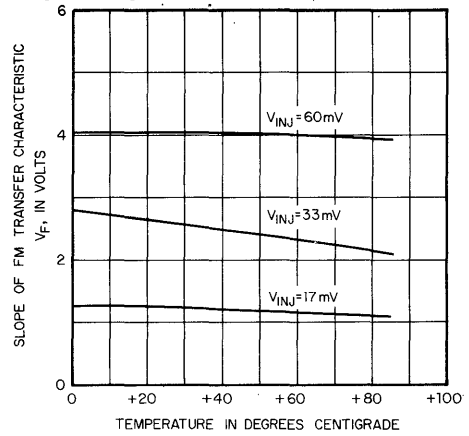

**AMPLIFIER VOLTAGE GAIN AS A FUNCTION OF OPERATING FREQUENCY AT  $V_{in} = 0.2 \text{ mV}_{\text{ms}}$**

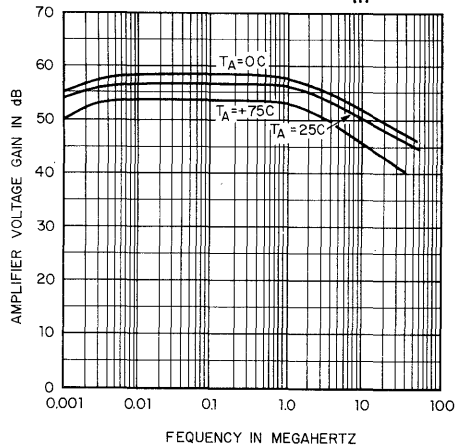

ALL CAPACITORS IN MICROFARADS

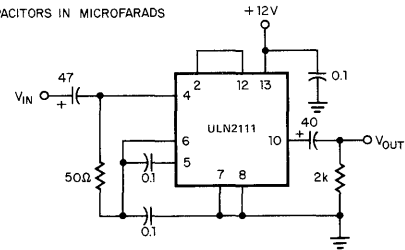

**SLOPE OF FM TRANSFER CHARACTERISTIC AS A FUNCTION OF SUPPLY VOLTAGE**

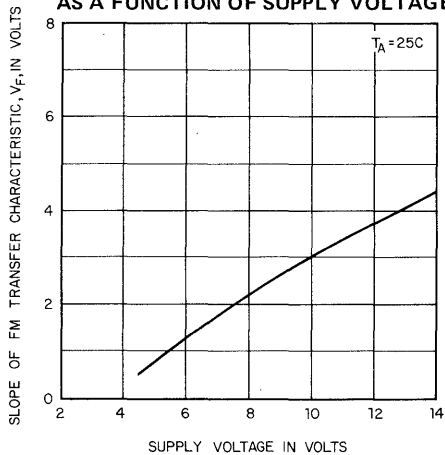

**PHASE SHIFT NETWORK (See Figure 4)**

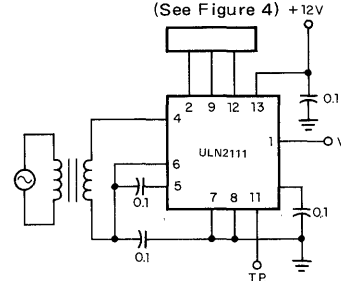

ALL CAPACITORS IN MICROFARADS

TYPICAL CHARACTERISTIC CURVES (Cont'd.)

SLOPE OF FM TRANSFER CHARACTERISTICS AS A FUNCTION OF INJECTION VOLTAGE

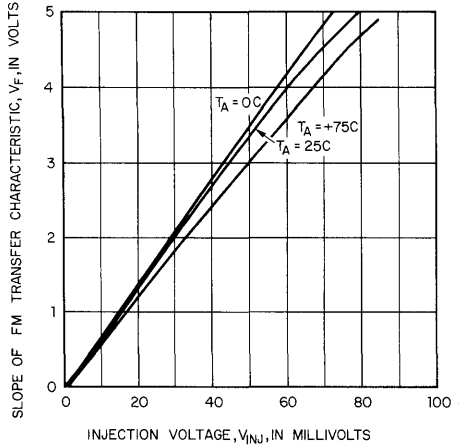

PHASE SHIFT NETWORK (See Figure 4)

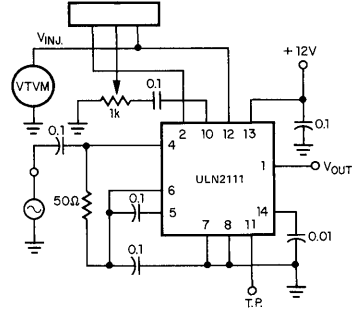

TRANSFER CHARACTERISTICS FOR A SIMPLE LC NETWORK

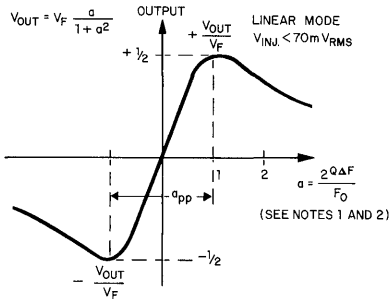

OUTPUT =  $f$  (NORMALIZED DEVIATION)  
 (The units along the vertical axis are arbitrary units.)  
 Linear mode: Operation of the FM detector with no limiting after the phase shift network.

NOTES:

1.  $V_F$  defines the slope of the FM transfer characteristic, at origin:

$$V_f = \frac{dV_{out}}{da} \quad a = 0$$

$V_F$  is primarily a function of bias current in the detector and injection voltage.

$V_F$  will decrease with decreasing  $V_{CC}$  or  $V_{INJ}$ .

2.  $a$  = normalized frequency deviation:

$$a = \frac{2Q\Delta F}{F_0}$$

# SECTION 8

## phase locked loops



## LINEAR INTEGRATED CIRCUITS

### DESCRIPTION

The NE560B Phase Locked Loop (PLL) is a monolithic signal conditioner, and demodulator system comprising a VCO, Phase Comparator, Amplifier and Low Pass Filter, interconnected as shown in the accompanying block diagram. The center frequency of the PLL is determined by the free running frequency ( $f_0$ ) of the VCO. This VCO frequency is set by an external capacitor and can be fine tuned by an optional Potentiometer. The low pass filter, which determines the capture characteristics of the loop, is formed by the two capacitors and two resistors at the Phase Comparator output.

The PLL system has a set of self biased inputs which can be utilized in either a differential or single ended mode. The VCO output, in differential form, is available for signal conditioning frequency synchronization, multiplication and division applications. Terminals are provided for optional extended control of the tracking range, VCO frequency, and output DC level.

The monolithic signal conditioner-demodulator system is useful over a wide range of frequencies from less than 1 Hz to more than 15 MHz with an adjustable tracking range of  $\pm 1\%$  to  $\pm 15\%$ .

### FEATURES

- FM DEMODULATION WITHOUT TUNED CIRCUITS
- NARROW BANDPASS - TO  $\pm 1\%$  ADJUSTABLE
- TRACKING RANGE
- EXACT FREQUENCY DUPLICATION IN HIGH NOISE ENVIRONMENT
- WIDE TRACKING RANGE  $\pm 15\%$
- HIGH LINEARITY - 1% DISTORTION MAX
- FREQUENCY MULTIPLICATION AND DIVISION
- THROUGH HARMONIC LOCKING

### APPLICATIONS

TONE DECODERS

FM IF STRIPS

TELEMETRY DECODERS

DATA SYNCHRONIZERS

SIGNAL RECONSTITUTION

SIGNAL GENERATORS

MODEMS

TRACKING FILTERS

SCA RECEIVERS

FSK RECEIVERS

WIDE BAND HIGH LINEARITY DETECTORS

### ABSOLUTE MAXIMUM RATINGS

Maximum Operating Voltage	26V
Input Voltage	1V Rms
Storage Temperature	-65°C to 150°C
Operating Temperature	0°C to 70°C
Power Dissipation	300 mw

Limiting values above which serviceability may be impaired

### PIN CONFIGURATION

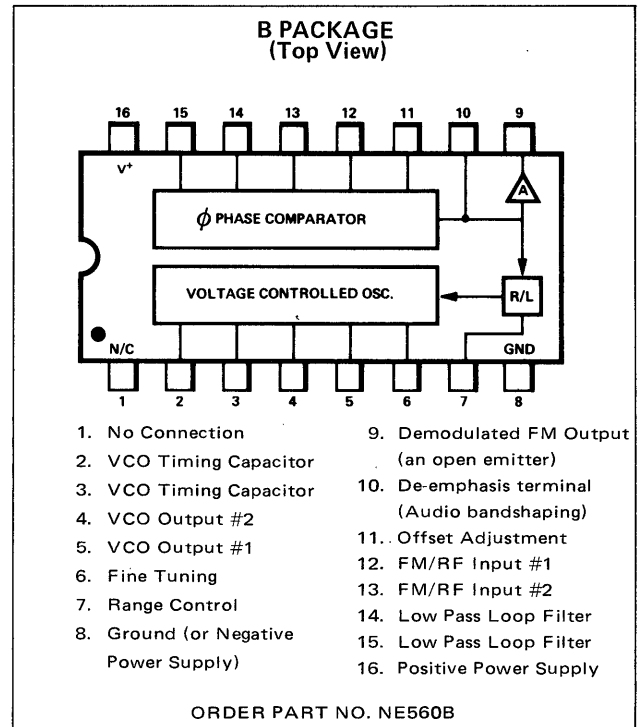

### BLOCK DIAGRAM

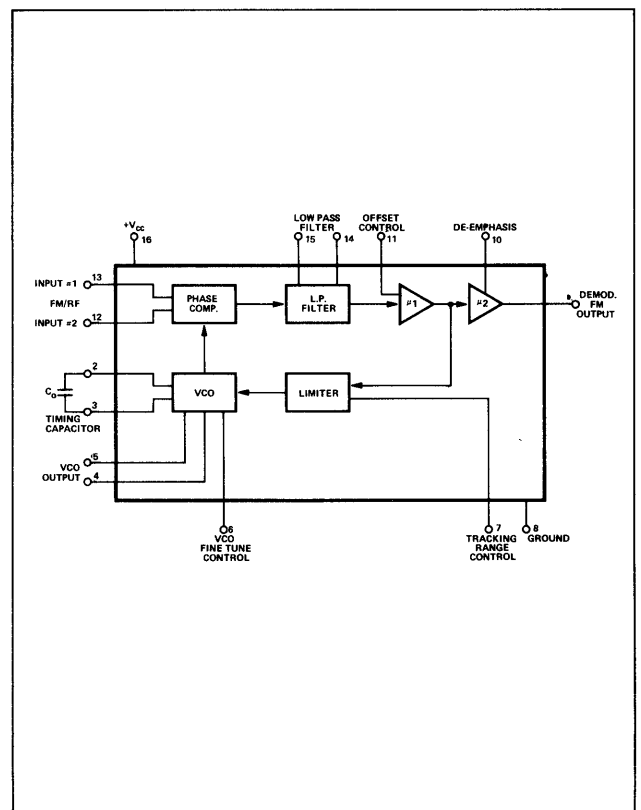



**SIGNETICS ■ 560 – PHASE LOCKED LOOP**

**GENERAL ELECTRICAL CHARACTERISTICS**

(15KΩ Pin 9 to GND, Input Pin 12 or Pin 13 AC Ground Unused Input, Optional Controls Not Connected, V+ = 18V Unless Otherwise Specified T<sub>A</sub> = 25°C)

CHARACTERISTICS	LIMITS				TEST CONDITIONS
	MIN	TYP	MAX	UNITS	
Lowest Practical Operating Frequency		0.1		Hz	Measured at 2 MHz, with both inputs AC grounded Measured at 2 MHz
Maximum Operating Frequency	15	30		MHz	
Supply Current	7	9	11	Ma	
Minimum Input Signal for Lock		100		μV	
Dynamic Range		60		dB	
VCO Temp Coefficient*		±0.06	±0.12	%/°C	
VCO Supply Voltage Regulation		±0.3	±2	%/V	
Input Resistance		2		KΩ	
Input Capacitance		4		Pf	
Input DC Level		+4		V	
Output DC Level	+12	+14	+16	V	
Available Output Swing		4		V <sub>p-p</sub>	
AM Rejection*	30	40		dB	
De-emphasis Resistance		8		KΩ	

\*ACC Test Sub Group C.

**ELECTRICAL CHARACTERISTICS (For FM Applications, Figure 2) (15KΩ Pin 9 to GND, Input Pin 12 or 13, AC Ground Unused Input, Optional Controls Not Connected, V+ = 18V Unless Otherwise Specified T<sub>A</sub> = 25°C)**

CHARACTERISTICS	LIMITS				TEST CONDITIONS
	MIN	TYP	MAX	UNITS	
<b>10.7 MHz Operation      Deviation 75 kHz Source Impedance = 50Ω</b>					
Detection Threshold		120	300	μV	V <sub>in</sub> = 1 mv Rms Modulation Frequency 1 kHz V <sub>in</sub> = 1 mv Rms Modulation Frequency 1 kHz V <sub>in</sub> = 1 mv Rms Modulation Frequency 1 kHz
Demodulated Output Amplitude	30	60		mV	
Distortion*		.3	1	% T.H.D.	
Signal to Noise Ratio $\frac{S+N}{N}$		35		dB	
<b>4.5 MHz Operation      Deviation = 25 kHz, Source Impedance = 50Ω</b>					
Detection Threshold		120	300	μV	V <sub>in</sub> = 1 mv Rms Modulation Frequency 1 kHz V <sub>in</sub> = 1 mv Rms Modulation Frequency 1 kHz V <sub>in</sub> = 1 mv Rms Modulation Frequency 1 kHz
Demodulated Output Amplitude	30	60		mV	
Distortion		0.3	1.0	% T.H.D.	
Signal to Noise Ratio $\frac{S+N}{N}$		35		dB	
<b>Wide Deviation      ΔF/f<sub>o</sub> = 5% Input = 4.5 MHz Deviation = 225 kHz @ 1 kHz Modulation Rate</b>					
Detection Threshold		1	5	mV	V <sub>in</sub> = 5 mv Rms V <sub>in</sub> = 5 mv Rms V <sub>in</sub> = 5 mv Rms
Demodulated Output	0.2	0.5		V <sub>rms</sub>	
Distortion		0.8		% T.H.D.	
Signal to Noise Ratio $\frac{S+N}{N}$		50		dB	

\*ACC Test Sub Group C.

**ELECTRICAL CHARACTERISTICS (For Tracking Filter, Figure 3) (15KΩ Pin 9 to GND, Input Pin 12 or Pin 13 AC Ground Unused Input, Optional Controls Not Connected, V+ = 18V Unless Otherwise Specified T<sub>A</sub> = 25°C)**

CHARACTERISTICS	LIMITS				TEST CONDITIONS
	MIN	TYP	MAX	UNITS	
Tracking Range	±5	±15		% of f <sub>o</sub>	V <sub>in</sub> = 5 mv Rms Input 2 MHz - See Characteristic Curves
Minimum Signal to Sustain Lock 0°C to 70°C		0.8		mv Rms	
VCO Output Impedance		1		kΩ	Input 2 MHz Measured with high impedance Probe with less than 10 Pf Capacitance
VCO Output Swing	0.4	0.6		V <sub>p-p</sub>	
VCO Output DC Level		+6.5		V	Input 2 MHz with ±100 kHz Side Band Separation and 3 kHz Low Pass Filter Input 1 mv Peak for Carrier Each Side Band C <sub>1</sub> = 0.01 μF R <sub>1</sub> = 0
Side Band Suppression		35		dB	

TYPICAL TEST CIRCUITS

AM REJECTION

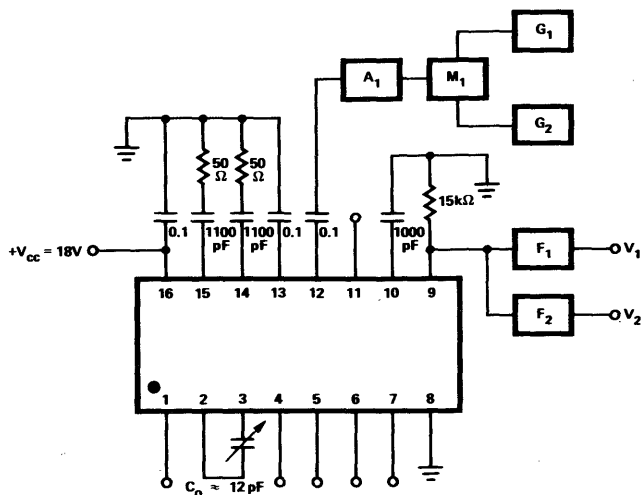

$G_1$  = FM Generator with  $f_c = f_o \approx 4$  MHz  
 $\Delta f = 40$  kHz,  
 $f_{mod} = 1$  kHz

$G_2$  = Audio Generator with  $f_A = 400$  Hz

$M_1$  = Balanced Modulator Carrier Supplied by  $G_1$ , AM modulation provided by  $G_2$ .

$A_1$  =  $50 \Omega$  attenuator pad with signal level into pin 12 adjusted to 1 mV rms.

$F_1$  = 1 kHz Bandpass filter,  $Q = 20$

$F_2$  = 400 Hz Bandpass filter with  $Q = 50$ , with 1 kHz trap.

$$AMR = \frac{V_1}{V_2} \text{ in dB}$$

$V_1$  and  $V_2$  are rms voltmeter readings.

Fig. 1

FM DEMODULATION

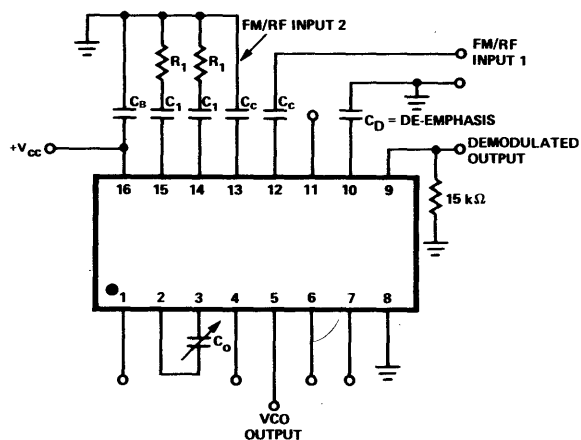

$C_B$  = Bypass Capacitor  
 $C_C$  = Coupling Capacitors  
 $C_1$  = Low Pass Filter Capacitors  
 $C_0$  = Frequency Determining Capacitor

$T_D$  = De-emphasis time constant  
 $= (C_D) (8k\Omega)$

Fig. 2

TRACKING FILTER

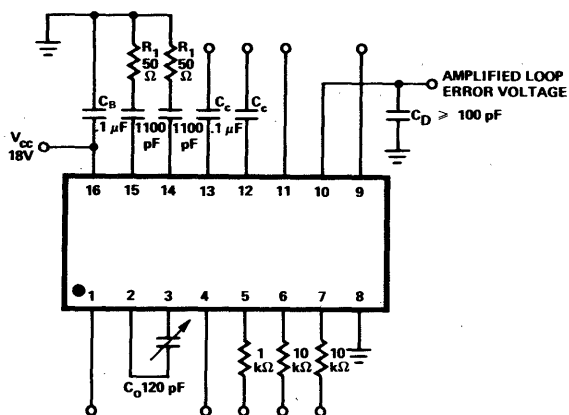

$C_C$  = Coupling Capacitors  
 $C_B$  = Bypass Capacitor  
 $C_1$  = Low Pass Filter Capacitor  
 $C_0$  = VCO Frequency Set Capacitor

Fig. 3

TYPICAL CHARACTERISTIC CURVES

MINIMUM INPUT SIGNAL AMPLITUDE NECESSARY TO MAINTAIN LOCK AS A FUNCTION OF TEMPERATURE WITH  $f_{\text{signal}} = f_{025^{\circ}\text{C}} = 2.0 \text{ MHz}$

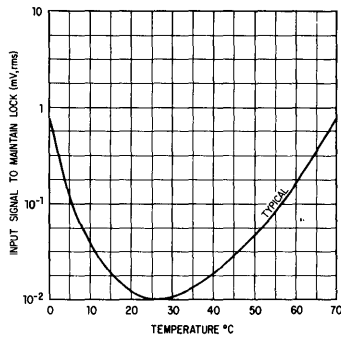

THERMAL DRIFT OF VCO FREE RUNNING FREQUENCY ( $f_0$ )

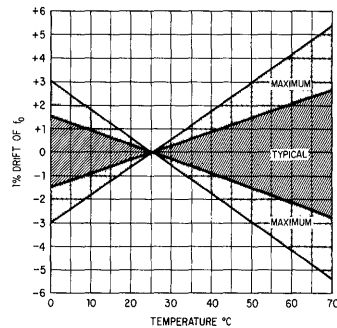

CHANGE OF FREE RUNNING OSCILLATOR FREQUENCY AS A FUNCTION OF FINE TUNING CIRCUIT

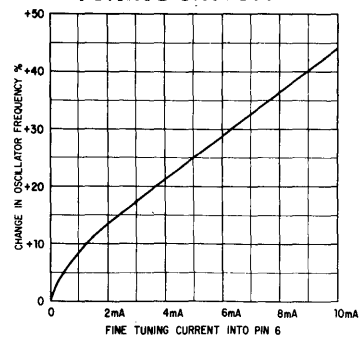

FREE RUNNING OSCILLATOR FREQUENCY AS A FUNCTION OF VCO TIMING CAPACITANCE

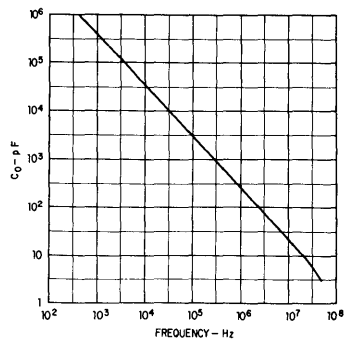

AM REJECTION AS A FUNCTION OF INPUT SIGNAL LEVEL  $f_0 = 10 \text{ MHz}$

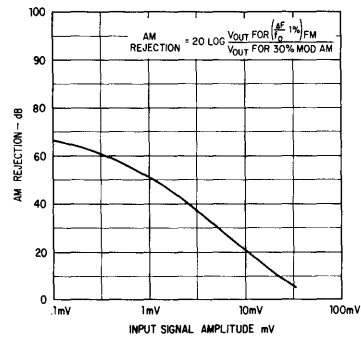

TYPICAL TRACKING RANGE AS A FUNCTION OF INPUT SIGNAL

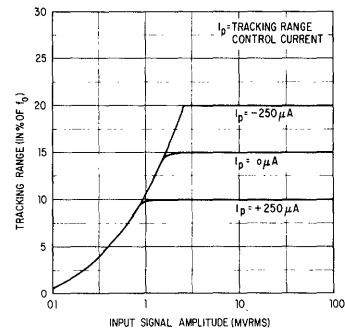

CHANGE OF FREE RUNNING OSCILLATOR FREQUENCY AS A FUNCTION OF RANGE CONTROL CURRENT

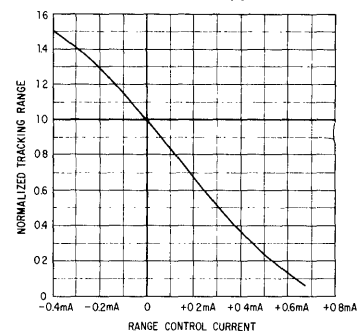

NORMALIZED TRACKING RANGE AS A FUNCTION OF RANGE CONTROL CURRENT

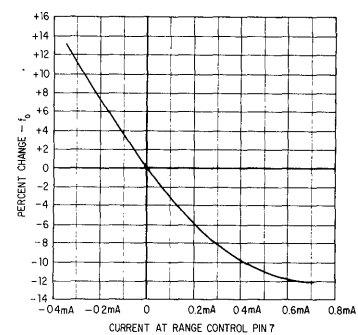

## EXTERNAL CONTROLS

### 1. Loop Low Pass Filter (Pins 14 and 15)

The equivalent circuit for the loop low-pass filter can be represented as:

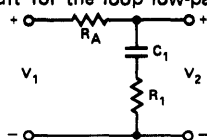

where  $R_A$  ( $6K \Omega$ ) is the effective resistance seen looking into Pin #14 or Pin #15.

The corresponding filter transfer characteristics are:

$$\frac{V_2}{V_1}(S) = (S) = \frac{1 + S R_1 C_1}{1 + S (R_1 + R_A) C_1}$$

where  $S$  is the complex frequency variable.

### 2. Loop Gain (Threshold) Control

The overall Phase Locked Loop gain can be reduced by connecting a feedback resistor,  $R_F$ , across the low-pass filter terminals, Pins #14 and #15. This causes the loop gain and the detection sensitivity to decrease by a factor  $\alpha$  ( $\alpha < 1$ )

where:

$$\alpha = \frac{R_F}{2 R_A + R_F}$$

Reduction of loop gain may be desirable at high input signal levels ( $V_{in} > 30 \text{ mV}$ ) and at high frequencies ( $f_o > 5 \text{ MHz}$ ) where excessively high loop gain may cause instability.

### 3. Tracking Range Control (Pin 7)

Any bias current,  $I_p$ , injected into the tracking range control, reduces the tracking range of the PLL by decreasing the output of the limiter. The variation of the tracking range and the center frequency, as a function of  $I_p$ , are shown in the characteristic curves with  $I_p$  defined positive going into the tracking range control terminal. This terminal is normally at a DC level of +0.6 Volts and presents an impedance of  $600 \Omega$ .

### 4. External Fine Tuning (Pin 6)

Any bias current injected into the fine tuning terminal increases the frequency of oscillation,  $f_o$ , as shown in the characteristic curves. This current is defined Positive into the fine tuning terminal. This terminal is at a typical DC level of +1.3 Volts and has a dynamic impedance of  $100 \Omega$  to ground.

### 5. Offset Adjustment (Pin 11)

Application of a bias voltage to the offset adjustment terminal modifies the current in the output amplifier setting the DC level at the output. The effect on the loop is to modify the relationship between the VCO free running frequency and the lock range, allowing the VCO free running frequency to be positioned at different points throughout the lock range.

Nominally this terminal is at +4V DC and has an input impedance of  $3K \Omega$ . The offset adjustment is optional. The characteristics specified correspond to operation of the circuit with this terminal open circuited.

### 6. De-emphasis Filter (Pin 10)

The de-emphasis terminal is normally used when the PLL is used to demodulate Frequency Modulated Audio signals. In this application, a capacitor from this terminal to ground provides the required de-emphasis. For other applications, this terminal may be used for band shaping the output signal. The 3 dB bandwidth of the output amplifier in the system block diagram (see Figure 2 .) is related to the de-emphasis capacitor,  $C_D$ , as:

$$f_{3dB} = \frac{1}{2 R_a C_D}$$

where  $R_D$  is the  $8000 \text{ ohm}$  resistance seen looking into the de-emphasis terminal.

When the PLL system is utilized for signal conditioning, and the loop error voltage is not utilized, de-emphasis terminal should be AC grounded.



## LINEAR INTEGRATED CIRCUITS

### DESCRIPTION

The NE561B Phase Locked Loop (PLL) is a monolithic signal conditioner, and demodulator system comprising a VCO, Phase Comparator, Amplifier and Low Pass Filter, interconnected as shown in the accompanying block diagram. The center frequency of the PLL is determined by the free running frequency ( $f_0$ ) of the VCO. This VCO frequency is set by an external capacitor and can be fine tuned by an optional Potentiometer. The low pass filter, which determines the capture characteristics of the loop is formed by the two capacitors and two resistors at the Phase Comparator output.

The PLL system has a set of self biased inputs which can be utilized in either a differential or single ended mode. The VCO output is available for signal conditioning, frequency synchronization, multiplication and division applications. Terminals are provided for optional external control of the tracking range, VCO frequency, and output DC level. An analog multiplier block is incorporated into the PLL system to provide frequency selective synchronous AM detection capability.

The monolithic signal conditioner-demodulator system is useful over a wide range of frequencies from less than 1 Hz to more than 15 MHz with an adjustable tracking range of  $\pm 1\%$  to  $\pm 15\%$ .

### FEATURES

- FM DEMODULATION WITHOUT TUNED CIRCUITS
- SYNCHRONOUS AM DETECTION
- NARROW BAND PASS TO  $\pm 1\%$
- EXACT FREQUENCY DUPLICATION IN HIGH NOISE ENVIRONMENT
- ADJUSTABLE TRACKING RANGE
- WIDE TRACKING RANGE  $\pm 15\%$
- HIGH LINEARITY - 1% DISTORTION MAX
- FREQUENCY MULTIPLICATION AND DIVISION THROUGH HARMONIC LOCKING

### BLOCK DIAGRAM

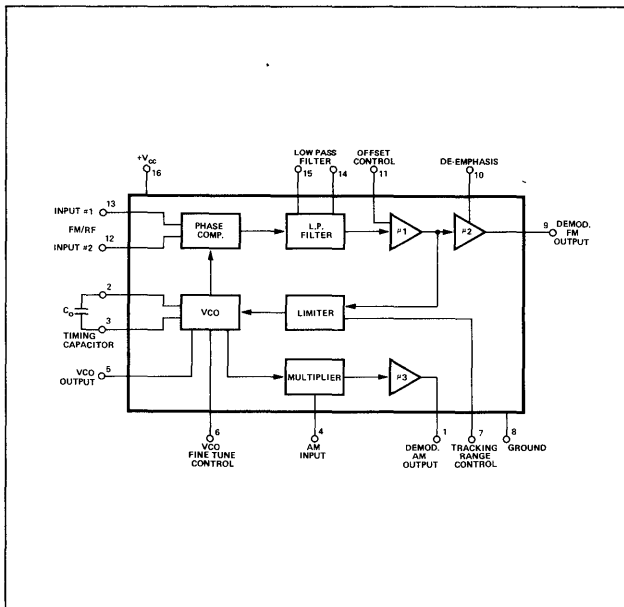

### PIN CONFIGURATION

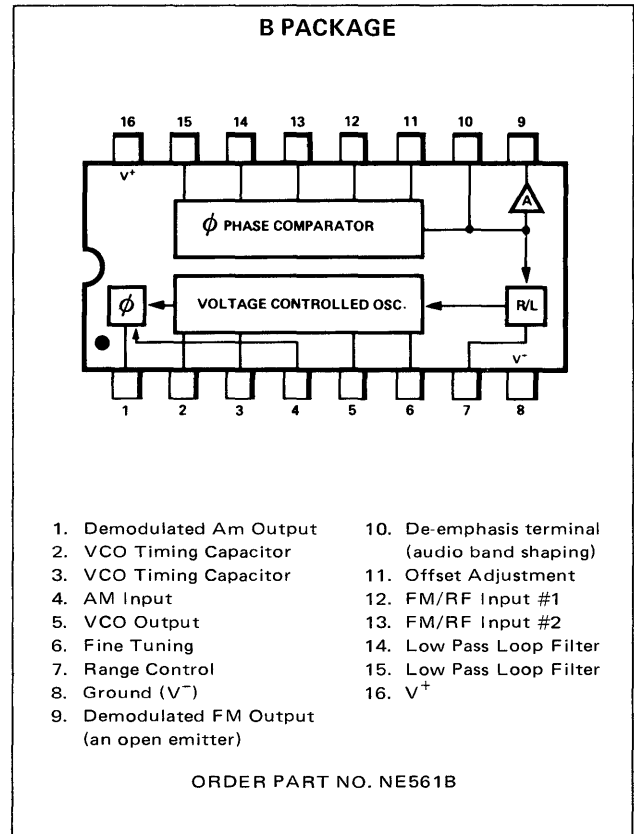

### ABSOLUTE MAXIMUM RATINGS

Maximum Operating Voltage	26V
Input Voltage	1V RMS
Storage Temperature	$-65^\circ\text{C}$ to $150^\circ\text{C}$
Operating Temperature	$0^\circ\text{C}$ to $70^\circ\text{C}$
Power Dissipation	300mW

Limiting values above which serviceability may be impaired

### APPLICATIONS

- TONE DECODERS
- AM-FM-IF STRIPS
- TELEMETRY DECODERS
- DATA SYNCHRONIZERS
- SIGNAL RECONSTITUTION
- SIGNAL GENERATORS
- MODEMS
- TRACKING FILTERS
- SCA RECEIVERS
- FSK RECEIVERS
- WIDE BAND HIGH LINEARITY DETECTORS
- SYNCHRONOUS DETECTORS
- AM RECEIVER

**SIGNETICS ■ 561 – PHASE LOCKED LOOP**

**GENERAL ELECTRICAL CHARACTERISTICS**

(15KΩ Pin 9 to GND, Input Pin 12 or Pin 13 AC Ground Unused Input, Optional Controls Not Connected, V+ = 18V Unless Otherwise Specified T<sub>A</sub> = 25°C)

CHARACTERISTICS	LIMITS				TEST CONDITIONS
	MIN	TYP	MAX	UNITS	
Lowest Practical Operating Frequency	15	0.1		Hz	Measured at 2 MHz, with both inputs AC grounded Measured at 2 MHz
Maximum Operating Frequency		30		MHz	
Supply Current	8	10	12	Ma	
Minimum Input Signal for Lock		100		μV	
Dynamic Range		60		dB	
VCO Temp Coefficient*		±0.06	±0.12	%/°C	
VCO Supply Voltage Regulation		±0.3	±2	%/V	
Input Resistance		2		kΩ	
Input Capacitance		4		pF	
Input DC Level		+4		V	
Output DC Level	+12	+14	+16	V	Measured at Pin 9 See Figure 3
Available Output Swing		4		V <sub>p-p</sub>	
AM Rejection*	30	40		dB	
De-emphasis Resistance		8		kΩ	

\*ACC Test Sub Group C.

**ELECTRICAL CHARACTERISTICS (For FM Applications, Figure 2)** (15KΩ Pin 9 to GND, Input Pin 12 or 13, AC Ground Unused Input, Optional Controls Not Connected, V+ = 18V Unless Otherwise Specified T<sub>A</sub> = 25°C)

CHARACTERISTICS	LIMITS				TEST CONDITIONS
	MIN	TYP	MAX	UNITS	
<b>10.7 MHz Operation      Deviation 75 kHz    Source Impedance = 50Ω</b>					
Detection Threshold		120	300	μV	Vin = 1 mv Rms    Modulation Frequency 1 kHz Vin = 1 mv Rms    Modulation Frequency 1 kHz Vin = 1 mv Rms    Modulation Frequency 1 kHz
Demodulated Output Amplitude	30	60		mV	
Distortion* Signal to Noise Ratio $\frac{S+N}{N}$		.3 35	1	% T.H.D. dB	
<b>4.5 MHz Operation      Deviation = 25 kHz, Source Impedance = 50Ω</b>					
Detection Threshold		120	300	μV	Vin = 1 mv Rms    Modulation Frequency 1 kHz Vin = 1 mv Rms    Modulation Frequency 1 kHz Vin = 1 mv Rms    Modulation Frequency 1 kHz
Demodulated Output Amplitude	30	60		mV	
Distortion Signal to Noise Ratio $\frac{S+N}{N}$		0.3 35	1.0	% T.H.D. dB	
<b>Wide Deviation      ΔF/f<sub>o</sub> = 5%    Input = 4.5 MHz    Deviation = 225 kHz @ 1 kHz modulation rate</b>					
Detection Threshold		1	5	mV	Vin = 5 mv Rms Vin = 5 mv Rms Vin = 5 mv Rms
Demodulated Output	0.2	0.5		V <sub>rms</sub>	
Distortion Signal to Noise Ratio $\frac{S+N}{N}$		0.8 50		% T.H.D. dB	

\*ACC Test Sub Group C.

**ELECTRICAL CHARACTERISTICS (For Tracking Filter, Figure 1)** (15KΩ Pin 9 to GND, Input Pin 12 or Pin 13 AC Ground Unused Input, Optional Controls Not Connected, V+ = 18V Unless Otherwise Specified T<sub>A</sub> = 25°C)

CHARACTERISTICS	LIMITS				TEST CONDITIONS
	MIN	TYP	MAX	UNITS	
Tracking Range	±5	±20		% of f <sub>o</sub>	Vin 5 mv Rms Input 2 MHz - See Characteristic Curves
Minimum Signal to Sustain Lock 0°C to 70°C		0.8		mv Rms	
VCO Output Impedance		1		kΩ	Input 2 MHz Measured with high impedance. Probe with less than 10 pF capacitance.
VCO Output Swing	0.4	0.6		V <sub>p-p</sub>	
VCO Output DC Level		+6.5		V	Input 2 MHz with ±100 kHz Sideband Separation and 3 kHz Low Pass Filter. Input 1 mv Peak for Carrier and each Sideband C <sub>1</sub> = 0.01 μF R <sub>1</sub> = 0
Side Band Suppression		35		dB	

**ELECTRICAL CHARACTERISTICS (For AM Synchronous Detector, Figure 4) (15KΩ Pin 9 to GND, Input Pin 12 or Pin 13 AC Ground Unused Input, Optional Controls Not Connected, V+ = 18V Unless Otherwise Specified T<sub>A</sub> = 25°C)**

CHARACTERISTICS	LIMITS				TEST CONDITIONS
	MIN	TYP	MAX	UNITS	
Input Impedance		3		kΩ	See Definition of Terms See Definition of Terms
Output Impedance		8		kΩ	
Output DC Level	+10	+14	+17	V	
AM Conversion Gain	3	12		dB	
Out of Band Rejection		30		dB	
Distortion		1•		% T.H.D.	

**TYPICAL TEST CIRCUITS**

**TEST CIRCUIT FOR TRACKING FILTER**

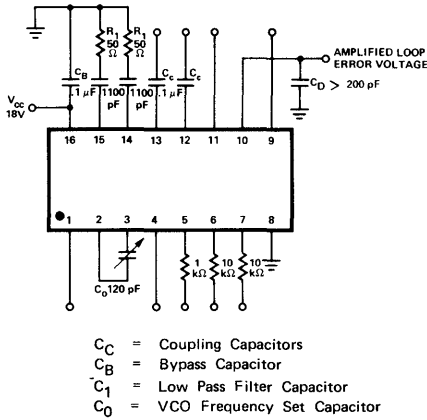
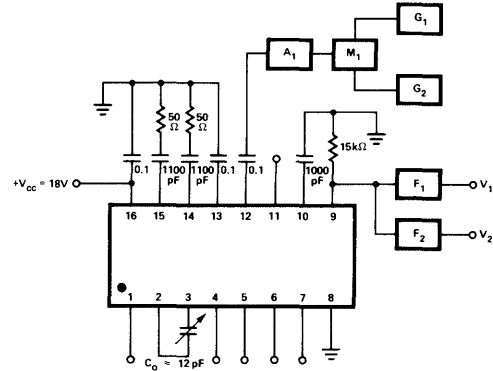

FIGURE 1

**TEST CIRCUIT FOR AM REJECTION**



- $G_1$  = FM Generator with  $f_c = f_o \approx 4$  MHz  
 $\Delta f = 40$  kHz,  $f_{mod} = 1$  kHz
  - $G_2$  = Audio Generator with  $f_A = 400$  Hz
  - $M_1$  = Balanced Modulator Carrier Supplied by  $G_1$ ,  
AM modulation provided by  $G_2$
  - $A_1$  = 50Ω attenuator pad with signal level into pin 12  
adjusted to 1 mV rms.
  - $F_1$  = 1 kHz Bandpass filter, Q = 20
  - $F_2$  = 400 Hz Bandpass filter with Q = 50, with  
1 kHz trap.
- $AMR = \frac{V_1}{V_2}$  in dB  $V_1$  and  $V_2$  are rms voltmeter readings.

FIGURE 3

**TEST CIRCUIT FOR FM DEMODULATION**

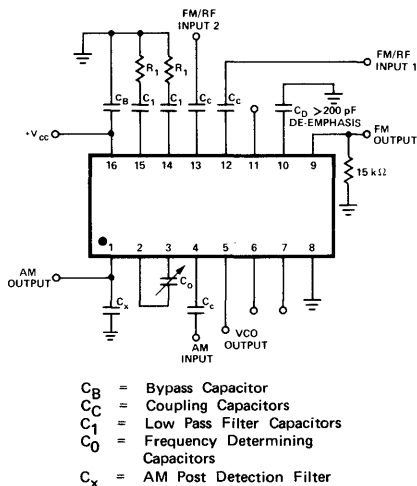

FIGURE 2

**TEST CIRCUIT FOR AM SYNCHRONOUS DETECTOR**

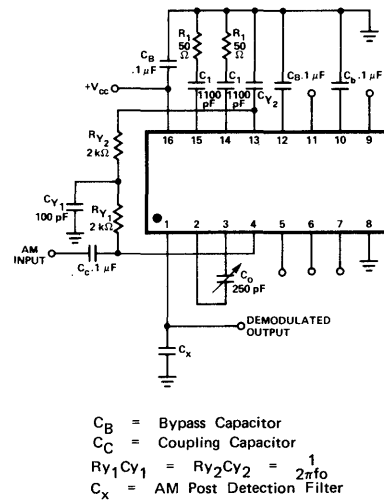
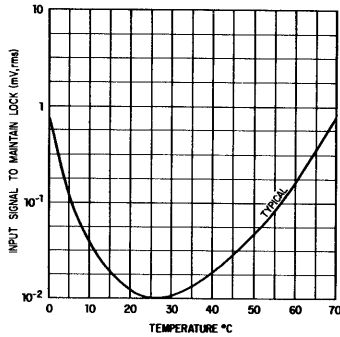

FIGURE 4



TYPICAL CHARACTERISTIC CURVES

MINIMUM INPUT SIGNAL AMPLITUDE NECESSARY TO MAINTAIN LOCK AS A FUNCTION OF TEMPERATURE WITH  $f_{\text{signal}} = f_{0_{25^{\circ}\text{C}}} = 2.0 \text{ MHz}$



THERMAL DRIFT OF VCO FREE RUNNING FREQUENCY ( $f_0$ )

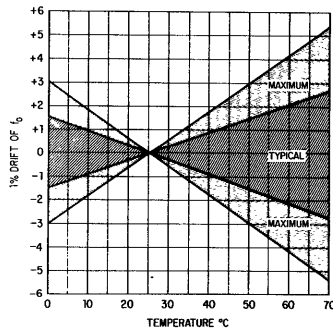

CHANGE OF FREE RUNNING OSCILLATOR FREQUENCY AS A FUNCTION OF RANGE CONTROL CURRENT

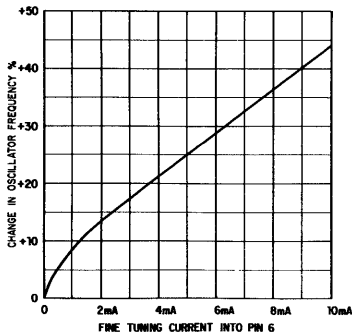

FREE RUNNING OSCILLATOR FREQUENCY AS A FUNCTION OF VCO TIMING CAPACITANCE

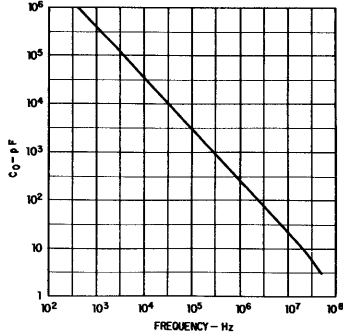

AM REJECTION AS A FUNCTION OF INPUT SIGNAL LEVEL  $f_0 = 10 \text{ MHz}$

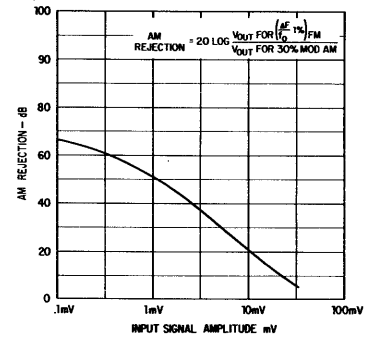

TYPICAL TRACKING RANGE AS A FUNCTION OF INPUT SIGNAL

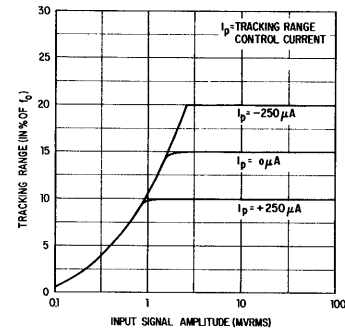

CHANGE OF FREE RUNNING OSCILLATOR FREQUENCY AS A FUNCTION OF FINE TUNING CIRCUIT

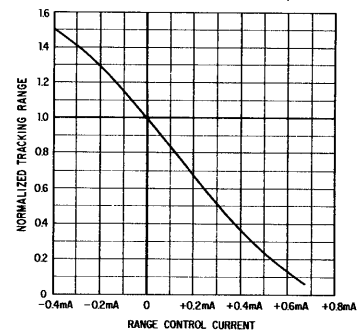

NORMALIZED TRACKING RANGE AS A FUNCTION OF RANGE CONTROL CURRENT

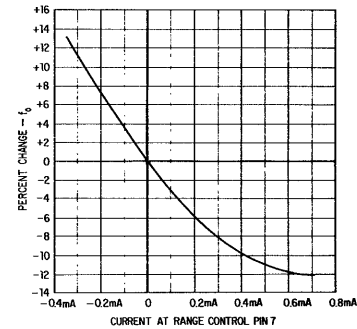

**EXTERNAL CONTROLS**

**1. Loop Low Pass Filter (Pins 14 and 15)**

The equivalent circuit for the loop low-pass filter can be represented as:

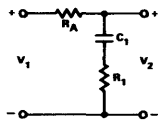

where RA (6kΩ) is the effective resistance seen looking into Pin # 14 or Pin #15.

The corresponding filter transfer characteristics are:

$$\frac{V_2}{V_1}(S) = F(S) = \frac{1 + S R_1 C_1}{1 + S (R_1 + R_A) C_1}$$

where S is the complex frequency variable.

**2. Loop Gain (Threshold) Control**

The overall Phase Lock of loop gain can be reduced by connecting a feedback resistor, RF, across the low-pass filter terminals, Pins #14 and #15. This causes the loop gain and the detection sensitivity to decrease by a factor (α < 1), where

$$\alpha = \frac{R_F}{2R_A + R_F}$$

Reduction of loop gain may be desirable at high input signal levels (Vin > 30 mV) and at high frequencies (fo > 5MHz) where excessively high PLL loop gain may cause instability within the loop.

**3. Tracking Range Control (Pin 7)**

Any bias current, Ip, injected into the tracking range control, reduces the tracking range of the PLL by decreasing the output of the limiter. The variation of the tracking range and the center frequency, as a function of Ip, are shown in the characteristic curves with Ip defined positive going into the tracking range control terminal. This terminal is normally at a DC level of +0.6 Volts and presents an impedance of 600Ω.

**4. External Fine Tuning (Pin 6)**

Any bias current injected into the fine tuning terminal increases

the frequency of oscillation, fo, as shown in the characteristic curves. This current is defined Positive into the fine tuning terminal. This terminal is at a typical DC level of +1.3 Volts and has a dynamic impedance of 100Ω to ground.

**5. Offset Adjustment (Pin 11)**

Application of a bias voltage to the offset adjustment terminal modifies the current in the output amplifier setting the DC level at the output. The effect on the loop is to modify the relationship between the VCO free running frequency and the lock range, allowing the VCO free running frequency to be positioned at different points throughout the lock range.

Nominally this terminal is at +4V DC and has an input impedance of 3kΩ. The offset adjustment is optional. The characteristics specified correspond to operation of the circuit with this terminal open circuited.

**6. De-emphasis Filter (Pin 10)**

The de-emphasis terminal is normally used when the PLL is used to demodulate Frequency Modulated Audio signals. In this application, a capacitor from this terminal to ground provides the required de-emphasis. For other applications, this terminal may be used for band shaping the output signal. The 3 dB bandwidth of the output amplifier in the system block diagram (see Figure 2 .) is related to the de-emphasis capacitor, CD, as:

$$f_{3dB} = \frac{1}{2\pi R_D C_D}$$

where RD is the 8000 ohm resistance seen looking into the de-emphasis terminal.

When the PLL system is utilized for signal conditioning, and the loop error voltage is not utilized, de-emphasis terminal should be AC grounded.

**7. AM Post-Detection Filter (Pin 1)**

The capacitor CX connected between Pin #1 and ground serves as a low-pass filter for synchronous AM detection with a transfer characteristic, F2(S), given as:

$$F_2(S) = \frac{1}{1 + S R_x C_x}$$

where Rx = 8kΩ is the resistance seen looking into Pin #1.



## LINEAR INTEGRATED CIRCUITS

### DESCRIPTION

The NE562B Phase Locked Loop (PLL) is a monolithic signal conditioner and demodulator system, comprising a VCO, phase comparator, amplifier and low pass filter, interconnected as shown in the accompanying block diagram. The center frequency of the PLL is determined by the free running frequency ( $f_0$ ) of the VCO. This VCO frequency is set by an external capacitor. The low pass filter, which determines the capture characteristics of the loop, is formed by two capacitors and two resistors at the phase comparator output.

This PLL has two sets of differential inputs, one for the FM/RF input and one for the phase comparator local oscillator input. Both sets of inputs can be used in either a differential or single-ended mode. The FM/RF inputs to the comparator are self-biased. An internally regulated voltage source is provided to bias the phase comparator local oscillator inputs. The VCO output, at high level and in differential form, is available for driving logic circuits in signal conditioning and synchronization, frequency multiplication and division applications. Terminals are also provided for the optional extension of the tracking range. The monolithic signal conditioner-demodulator system is useful over a wide range of frequencies from less than 1 Hz to more than 15 MHz with an adjustable tracking range of  $\pm 1\%$  to  $\pm 15\%$ .

### FEATURES

- FREQUENCY MULTIPLICATION AND DIVISION
- SIGNAL CONDITIONING AND SIDE-BAND SUPPRESSION
- FM DEMODULATION WITHOUT TUNED CIRCUITS
- NARROW BANDPASS – TO  $\pm 1\%$
- ADJUSTABLE TRACKING RANGE – TO  $\pm 15\%$
- EXACT FREQUENCY DUPLICATION IN HIGH NOISE ENVIRONMENT
- HIGH LINEARITY – 1% DISTORTION MAXIMUM AT 1% DEVIATION

### APPLICATIONS

- FREQUENCY SYNTHESIZERS
- DATA SYNCHRONIZERS
- SIGNAL CONDITIONING
- TRACKING FILTERS
- TELEMETRY DECODERS
- MODEMS
- FM IF STRIPS AND DEMODULATORS
- TONE DECODERS
- FSK RECEIVERS
- WIDEBAND HIGH LINEARITY FM DEMODULATORS

### PIN CONFIGURATION

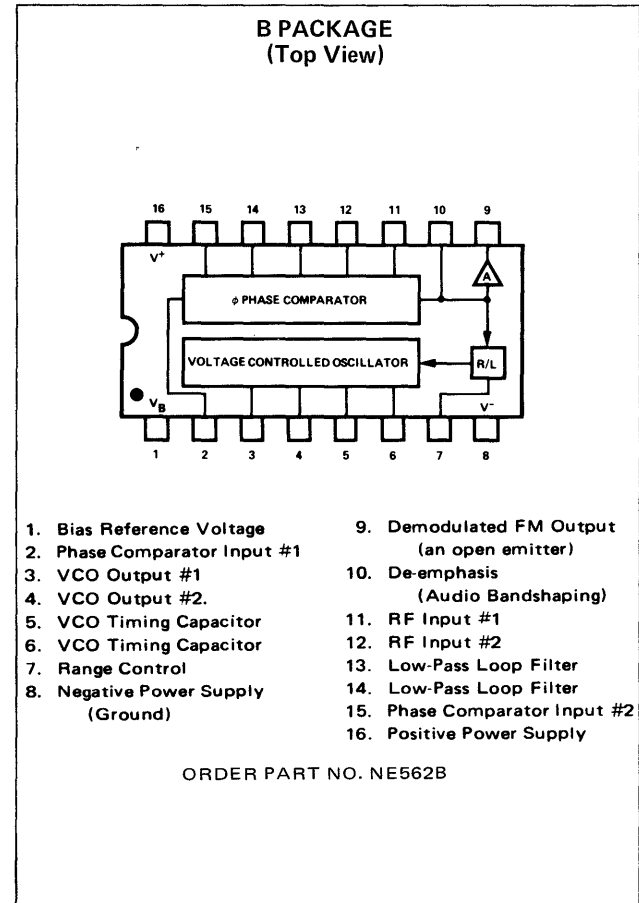

### BLOCK DIAGRAM

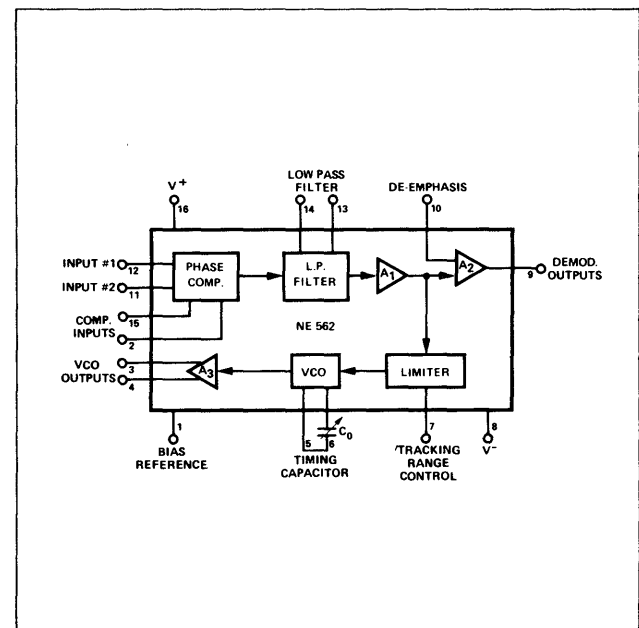

**SIGNETICS ■ 562 – PHASE LOCKED LOOP**

**ABSOLUTE MAXIMUM RATINGS**(Limiting values above which serviceability may be impaired)

Maximum Operating Voltage	30V
Input Voltage	3V rms
Storage Temperature	-65°C to 150°C
Operating Temperature	0°C to 70°C
Power Dissipation	300mW

**GENERAL ELECTRICAL CHARACTERISTICS**

(15,000 ohms pin 9 to ground, 12,000 ohms pins 3 and 4 to ground, pins 2 and 15 to pin 1 through 1000 ohms, input to pin 11 or 12 with unused input at AC ground, range control not connected and V<sup>+</sup> = 18 volts unless otherwise specified. T<sub>A</sub> = 25°C.)

CHARACTERISTICS	LIMITS			UNITS	TEST CONDITIONS
	MIN	TYP	MAX		
Lowest Practical Operating Frequency		0.1		Hz	
Maximum Operating Frequency	15	30		MHz	
Supply Current	10	12	14	mA	
Minimum Input Signal for Lock		200		μV	
Dynamic Range		80		dB	
VCO Temp Coefficient*		±0.06	±0.15	%/°C	Measured at 2 MHz
VCO Supply Voltage Regulation		±0.3	±2	%/V	Measured at 2 MHz
Input Resistance		2		kΩ	
Input Capacitance		4		pF	
Input DC Level	+12	+14	+16	V	
Output DC Level	+12	+14	+16	V	
Available Output Swing		4		V <sub>p-p</sub>	Measured at Pin 9
AM Rejection*	30	40		dB	See Definition of Terms
De-emphasis Resistance		8		kΩ	
Bias Reference		+8		V	

\* ACC Test Sub Group C.

**SCHEMATIC DIAGRAM**

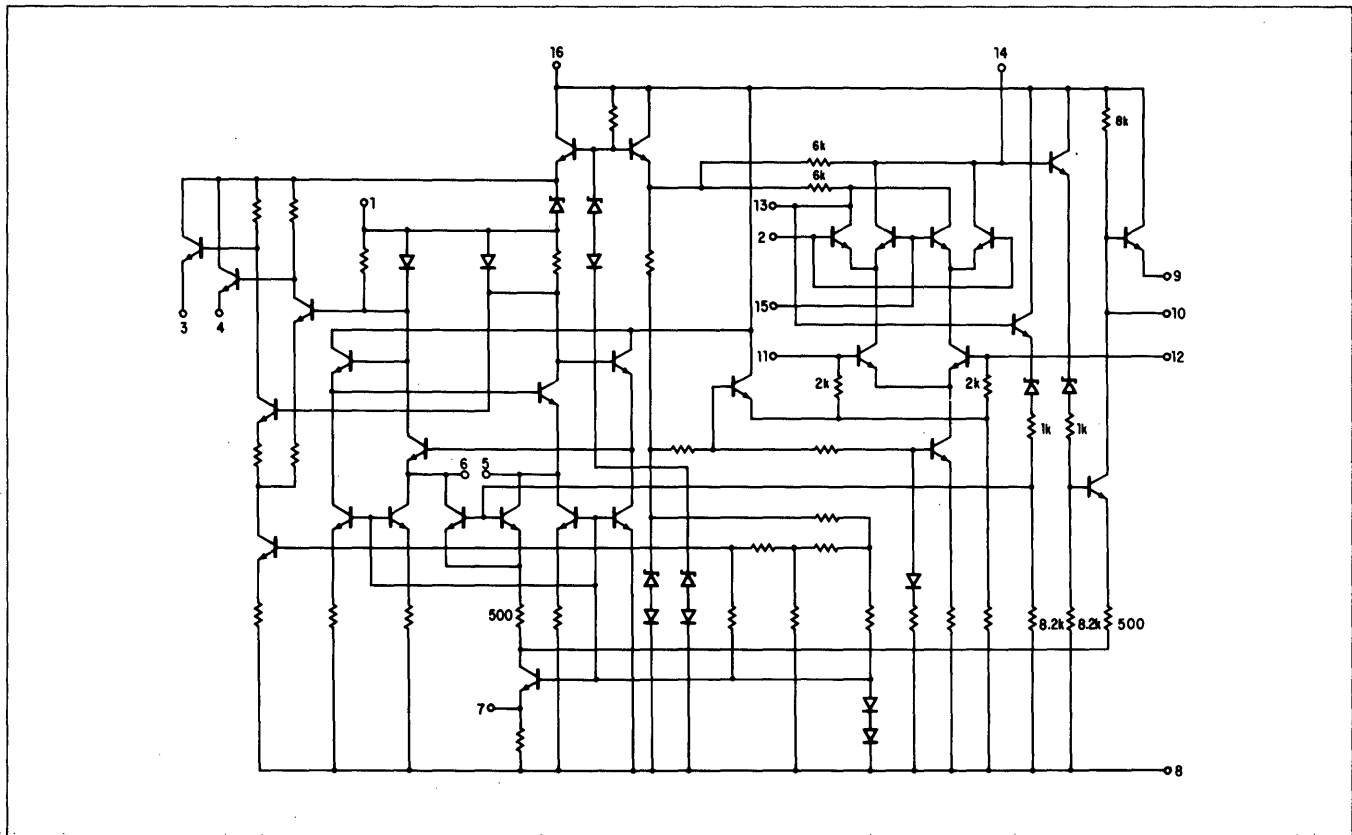

**ELECTRICAL CHARACTERISTICS FOR FM APPLICATIONS** (15,000 ohms pin 9 to ground, input to pin 11 or pin 12, AC ground unused input, range control not connected and  $V^+ = 18$  volts.  $T_A = 25^\circ\text{C}$ .)

CHARACTERISTICS	LIMITS			UNITS	TEST CONDITIONS
	MIN	TYP	MAX		
<b>10.7 MHz Operation</b> Deviation 75 kHz Source Impedance = $50\Omega$					
Detection Threshold		200	500	$\mu\text{V}$	$V_{in} = 1$ mV rms Modulation Frequency 1 kHz $V_{in} = 1$ mV rms Modulation Frequency 1 kHz $V_{in} = 1$ mV rms Modulation Frequency 1 kHz
Demodulated Output Amplitude	30	70		mV rms	
Distortion*		0.5		% T.H.D.	
Signal to Noise Ratio $\frac{S+N}{N}$		35		dB	
<b>4.5 MHz Operation</b> Deviation = 25 kHz, Source Impedance = $50\Omega$					
Detection Threshold		200	500	$\mu\text{V}$	$V_{in} = 1$ mV rms Modulation Frequency 1 kHz $V_{in} = 1$ mV rms Modulation Frequency 1 kHz $V_{in} = 1$ mV rms Modulation Frequency 1 kHz
Demodulated Output Amplitude	30	60		mV rms	
Distortion		0.5		% T.H.D.	
Signal to Noise Ratio $\frac{S+N}{N}$		35		dB	
<b>Wide Deviation</b> $\Delta F/f_0 = 5\%$ Input = 4.5 MHz Deviation = 225 kHz @ 1 kHz Modulation Rate					
Detection Threshold		1	5	mV	$V_{in} = 5$ mV rms $V_{in} = 5$ mV rms $V_{in} = 5$ mV rms
Demodulated Output		1		V rms	
Distortion	0.3	0.8		% T.H.D.	
Signal to Noise Ratio $\frac{S+N}{N}$		50		dB	

\*ACC Test Sub Group C.

**ELECTRICAL CHARACTERISTICS FOR SIGNAL CONDITIONER AND FREQUENCY SYNTHESIS APPLICATIONS** (Input to pin 11 or pin 12, AC ground unused input, range control not connected,  $V^+ = 18$  volts.  $T_A = 25^\circ\text{C}$ .)

CHARACTERISTIC	LIMITS			UNITS	TEST CONDITIONS
	MIN	TYP	MAX		
Tracking Range	$\pm 5$	$\pm 15$		% of $f_0$	200 mV p-p square wave input  Inputs at AC ground
Input Resistance		2		$k\Omega$	
Input Capacitance		4		pF	
Input DC Level		4		V	
VCO Output Impedance		1.3	2.5	$k\Omega$	
VCO Output Swing	3	4.5		V p-p	
VCO Output DC Level		12		V	
VCO Signal/Noise Ratio		60		dB	

**TEST CIRCUIT**

**TEST CIRCUIT FOR FM DEMODULATION**

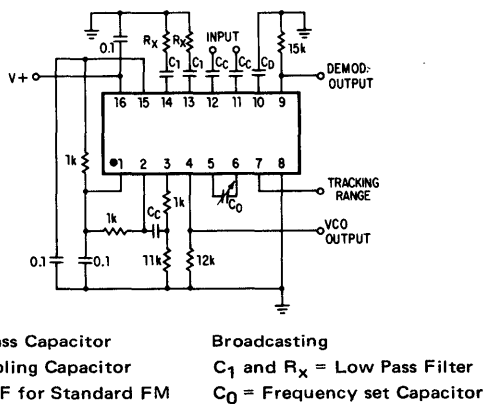

**FIGURE 1**

**TEST CIRCUIT FOR SIGNAL CONDITIONER AND FREQUENCY SYNTHESIS APPLICATIONS**

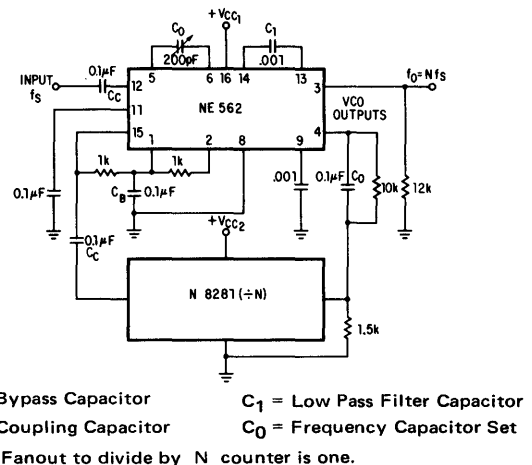

**FIGURE 2**

TYPICAL CHARACTERISTIC CURVES

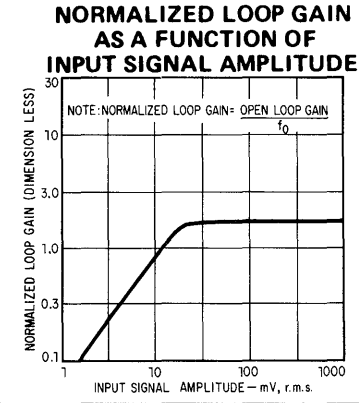
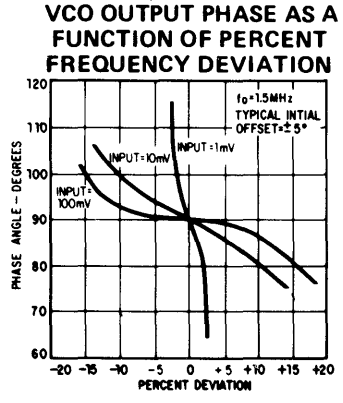
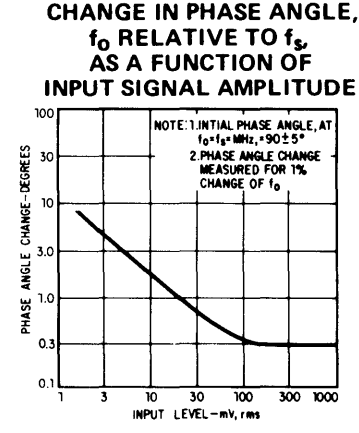
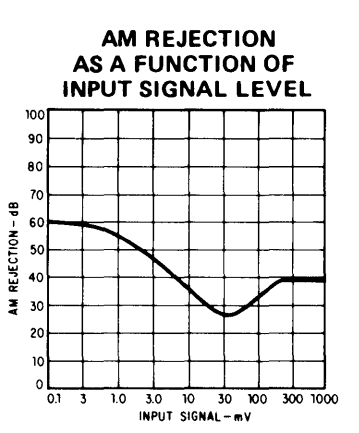
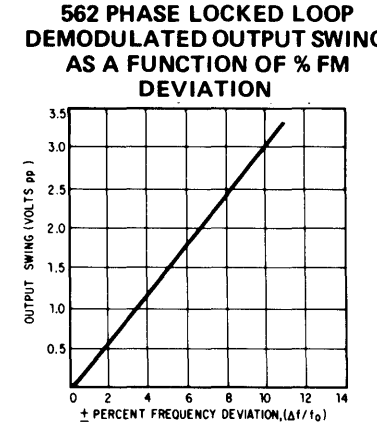
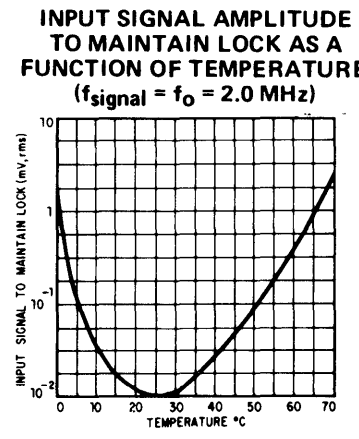
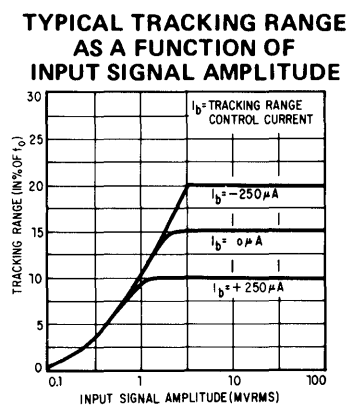
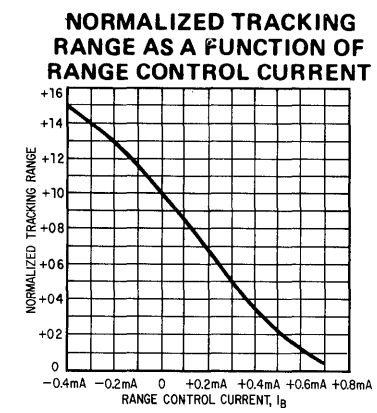
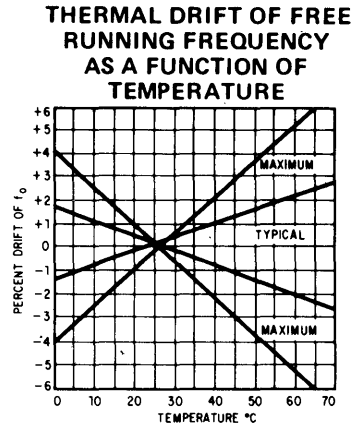
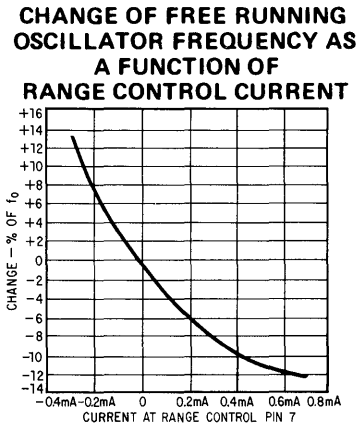
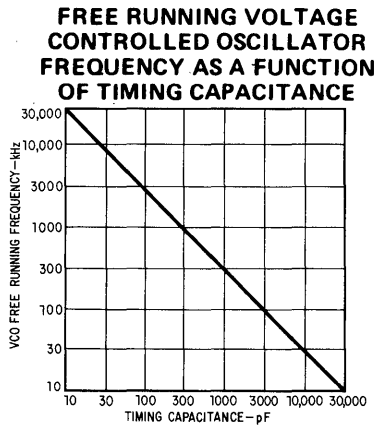

**562 APPLICATIONS INFORMATION**

**1. BIAS REFERENCE**

Pin 1 of the 562 is an internally regulated bias reference voltage supply which should be used as a source of bias current for the phase comparator input terminals, Pins 2 and 15. Biasing may be achieved as shown in Figure 3.

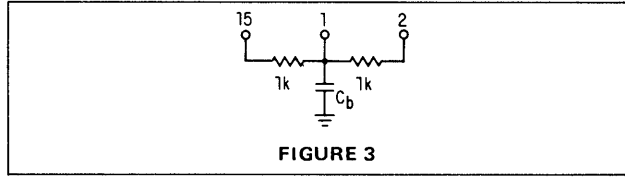

FIGURE 3

**2. PHASE COMPARATOR LOOP INPUTS**

Of the Signetics high frequency phase locked loops, the 562 is unique in that the loop is open between the VCO and the phase comparator. Once biasing of the comparator is accomplished, as described in Bias Reference above, loop closure can be accomplished by capacitive coupling between either one or both inputs of the phase comparator and the VCO output. A divider or counter may be enclosed in the loop at this point for frequency synthesis applications or a flip-flop may be used to ensure that the output waveform has a 50% duty cycle. If large signal swings, greater than 2 volts, are to be applied to the phase comparator inputs, a 1000 ohm current limiting buffer resistor should be used in series with the coupling capacitors.

**3. VCO OUTPUT**

Square wave VCO outputs of both polarities (0°C and 180°C) buffered by an amplifier are available at pins 3 and 4. For proper operation of the buffer amplifier, pins 3 and 4 must be returned to ground (or the negative supply) through resistors, typically 12,000 ohms. The value of these resistors may be reduced provided that total power dissipated in the 562 does not exceed 300 milliwatts or the total average current in each emitter does not exceed 4 mA. The output amplitude is typically 4.5 volts peak referenced at +12 volts with respect to pin 8.

**4. VCO TUNING**

Setting the free-running frequency of the VCO is accomplished easily with one timing capacitor connected between pins 5 and 6. For the 562 Phase Locked Loop, fine tuning of the free-running frequency may be accomplished in either or both of two ways. The first method uses a trimmer capacitor connected in parallel with the VCO timing capacitor. This is the simplest technique and requires the smallest number of extra components but at the lower frequencies may be difficult to implement. The second technique incorporates two resistors and a voltage source. The resistors are connected between each of the timing capacitor terminals and a voltage source as shown in Figure 4.

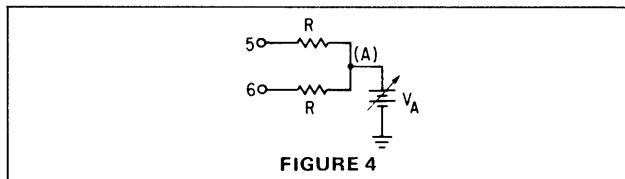

FIGURE 4

The percent change in the VCO free-running frequency,  $f_0$ , as a function of the voltage applied to point (A) is shown in the curves of Figure 5. Note that with this fine tuning technique, it is possible to *increase* the VCO free-running frequency to a value greater than possible with just a trimmer capacitor alone. A formula for the approximation of the VCO frequency as a function of the voltage at point (A), the resistance values and the starting frequency, is given below:

$$f = f_0 \left[ 1 - \frac{V_A - 6.4}{1300R} \right]$$

The recommended resistance range of R is 20,000 to 60,000 ohms.

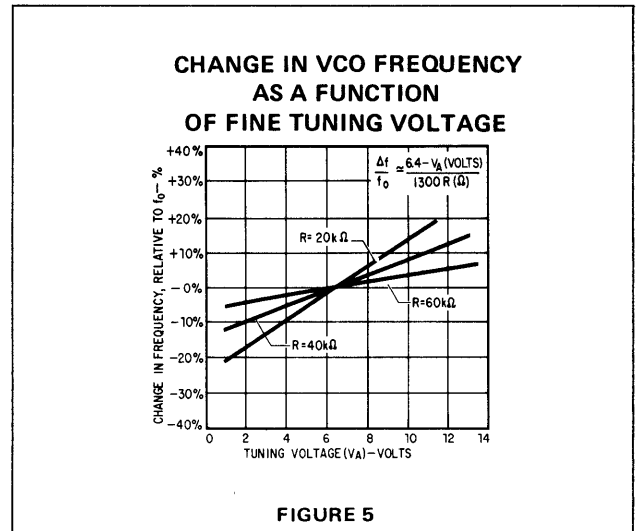

FIGURE 5

**5. LOOP GAIN CHARACTERISTICS**

The overall open loop gain of the 562 PLL can be expressed as:

$$K_0 = K_1 K_2$$

where:

$K_0$  = total open loop gain

$K_1$  = phase comparator and amplifier conversion gain

$K_2$  = VCO conversion gain

The VCO conversion gain,  $K_2$ , is the change of VCO frequency per unit of error voltage. In this particular design, it is numerically equal to the VCO frequency, i.e.,

$$K_2 = f_0 \text{ Hz/Volt}$$

or

$$K_2 = 2\pi f_0 \text{ radians/Volt-second}$$

The phase comparator and amplifier conversion gain,  $K_1$ , is proportional to input signal amplitude for low input levels,  $V_s \leq 40\text{mV rms}$ , and it is constant and equal to about 1.5 volts/radian for higher input amplitudes. Therefore,  $K_1$  can be approximated as:

$$K_1 \cong \frac{.04 V_s}{\sqrt{1 + \left(\frac{V_s}{40}\right)^2}}$$

where

$V_s$  = input signal in mV rms.



562 APPLICATIONS INFORMATION (Cont'd.)

6. SIGNAL INPUT

The input structure is basically differential and may be used in this manner. Biasing is supplied to the input terminals from an internal regulated supply so signal inputs must be capacitively coupled. In most applications where the input is single-ended, the unused input should be bypassed to ground.

7. DEMODULATED OUTPUT

Pin 9 is a low impedance output terminal for the loop error voltage. It is at this point that the demodulated FM output is obtained. When used, it must be biased by a resistor to ground (or negative supply), and the resistor value may be adjusted downward provided that the output current does not exceed 5mA or the dissipation in the 562 does not exceed the absolute maximum ratings. When not used, pin 9 may be left open.

8. DE-EMPHASIS FILTER

The de-emphasis terminal, pin 10, is normally required when the PLL is used to demodulate Frequency Modulated Audio signals. In this application, a capacitor from this terminal to ground provides the required de-emphasis. For other applications it may be used to shape the output response. The 3 dB bandwidth of the output amplifier is related to the de-emphasis capacitor,  $C_D$ , as:

$$f_{3dB} = \frac{1}{2\pi R_D C_D}$$

where  $R_D$  is 8000 ohms.

When the PLL system is utilized for applications not requiring the use of the output amplifier, pin 10 should be by-passed to ground.

9. TRACKING RANGE CONTROL (Pin 7)

Any bias current,  $I_p$ , injected into the tracking range control, reduces the tracking range of the PLL by decreasing the output of the limiter. The variation of the tracking range and the center frequency, as a function of  $I_p$ , are shown in the characteristic curves with  $I_p$  defined positive going into the tracking range control terminal. This terminal is normally at a DC level of +0.6 volts and presents an impedance of 600Ω.

10. LOW-PASS FILTER

In most applications, a loop low-pass filter should be connected between pins 13 and 14 and ground. It is used to set the loop response time, controlling the capture range and the rejection of out of band information. Four filter configurations and their transfer functions are shown in Figures 6 through 9. For VCO operating frequencies below 5 MHz, configurations shown in Figures 6 and 7 may be used. At higher frequencies, configurations shown in Figures 8 and 9 should be used to ensure loop stability. R is the impedance seen looking into the low pass filter terminals, Pins 13 and 14; and, in the 562, is nominally 6000 ohms.

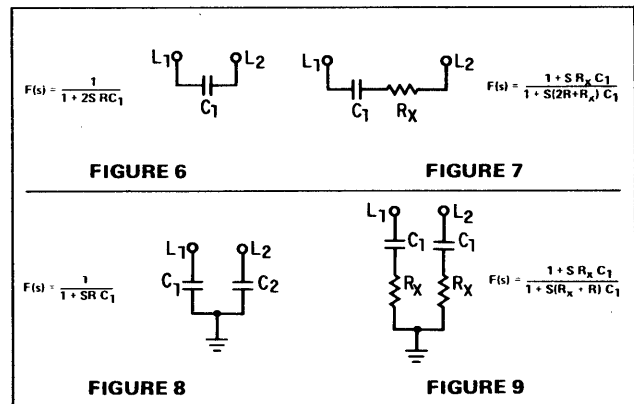

11. LOOP GAIN (Threshold) CONTROL

The overall Phase Locked Loop gain can be reduced by connecting a resistor,  $R_F$ , across the low-pass filter terminals, pins 13 and 14. This causes the loop gain and the detection sensitivity to decrease by a factor  $\alpha$ , where:

$$\alpha = \frac{R_F}{12,000 + R_F}$$

Reduction of loop gain may be desirable at operating frequencies greater than 5 MHz because, at these frequencies, high loop gain may cause instability.

12. STATIC LOOP PHASE-ERROR

When the PLL is in lock, the VCO outputs have a nominal  $\pm 90^\circ C$  phase shift with respect to the input signal. Due to internal offsets, this nominal angle at perfect lock condition may shift a few degrees, typically  $\pm 5^\circ C$  or less.

## LINEAR INTEGRATED CIRCUITS

### DESCRIPTION

The SE/NE565 Phase-Locked Loop (PLL) is a self-contained, adaptable filter and demodulator for the frequency range from 0.001 Hz to 500 kHz. The circuit comprises a voltage-controlled oscillator of exceptional stability and linearity, a phase comparator, an amplifier and a low-pass filter as shown in the block diagram. The center frequency of the PLL is determined by the free-running frequency of the VCO; this frequency can be adjusted externally with a resistor or a capacitor. The low-pass filter, which determines the capture characteristics of the loop, is formed by an internal resistor and an external capacitor.

### FEATURES

- **EXTREME STABILITY OF CENTER FREQUENCY (200ppm/°C typ)**
- **WIDE RANGE OF OPERATING VOLTAGE ( $\pm 5$  to  $\pm 12$  VOLTS) WITH VERY SMALL FREQUENCY DRIFT (100ppm/% typ)**
- **VERY HIGH LINEARITY OF DEMODULATED OUTPUT (0.2% typ)**
- **CENTER FREQUENCY PROGRAMMING BY MEANS OF A RESISTOR, CAPACITOR, VOLTAGE OR CURRENT**
- **TTL AND DTL COMPATIBLE SQUARE-WAVE OUTPUT; LOOP CAN BE OPENED TO INSERT DIGITAL FREQUENCY DIVIDER**
- **HIGHLY LINEAR TRIANGLE WAVE OUTPUT**
- **REFERENCE OUTPUT FOR CONNECTION OF COMPARATOR IN FREQUENCY DISCRIMINATOR**
- **BANDPASS, ADJUSTABLE FROM  $<\pm 1\%$  to  $>\pm 60\%$**
- **FREQUENCY ADJUSTABLE OVER 10 TO 1 RANGE WITH SAME CAPACITOR**

### BLOCK DIAGRAM

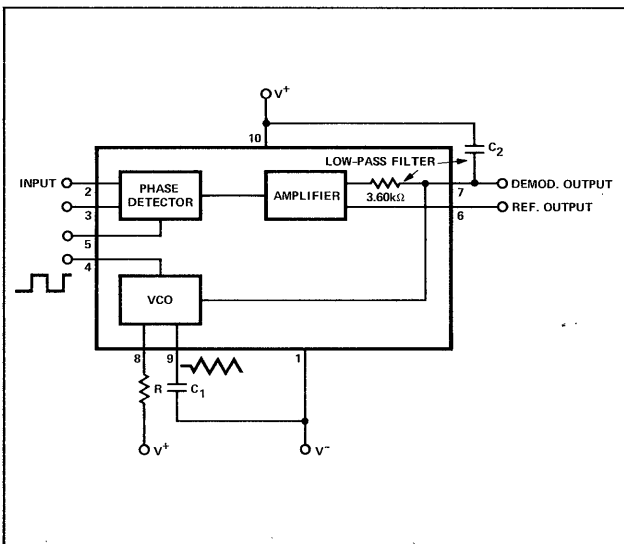

### PIN CONFIGURATIONS

#### A PACKAGE (Top View)

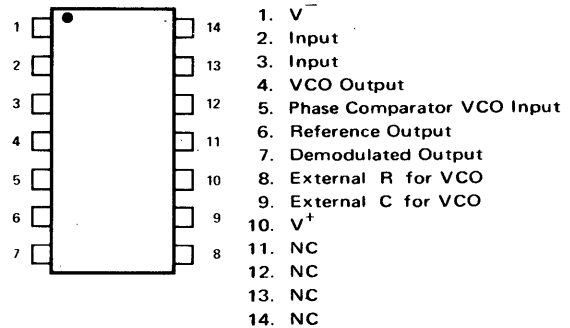

ORDER PART NOS. SE565A/NE565A

#### K PACKAGE

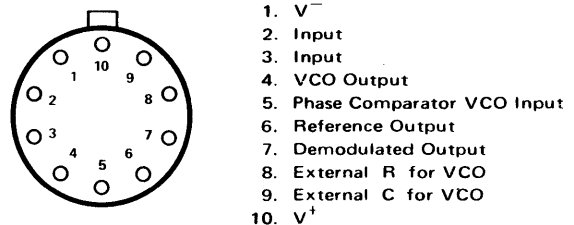

ORDER PART NOS. SE565K/NE565K

### APPLICATIONS

FREQUENCY SHIFT KEYING

MODEMS

TELEMETRY RECEIVERS

TONE DECODERS

SCA RECEIVERS

WIDEBAND FM DISCRIMINATORS

DATA SYNCHRONIZERS

TRACKING FILTERS

SIGNAL RESTORATION

FREQUENCY MULTIPLICATION & DIVISION

**SIGNETICS ■ SE/NE565 – PHASE LOCKED LOOP**

**ABSOLUTE MAXIMUM RATINGS (limiting values above which serviceability may be impaired)**

Maximum Operating Voltage	26V
Storage Temperature	-65°C to 150°C
Power Dissipation	300mW

**ELECTRICAL CHARACTERISTICS ( $T_A = 25^\circ\text{C}$ ,  $V_{CC} = \pm 6$  Volts unless otherwise noted)**

PARAMETER	TEST CONDITIONS	SE565			NE565			UNITS
		MIN	TYP	MAX	MIN	TYP	MAX	
<b>SUPPLY REQUIREMENTS</b>								
Supply Voltage		±5		±12	±5		±12	V
Supply Current			8	12.5		8	12.5	mA
<b>INPUT CHARACTERISTICS</b>								
Input Impedance	$-4V \leq V_2, V_3 \leq +1V$	7	10		5	10		kΩ
Input Level Required for Tracking	$f_0 = 50$ kHz ±10% frequency deviation	10	1		10	1		mVrms
<b>VCO CHARACTERISTICS</b>								
Center Frequency								
Maximum Value	$C_1 = 2.7$ pF	300	500			500		kHz
Distribution	Distribution taken about $f_0 \approx 50$ kHz $R_1 = 5.0k, C_1 = 1200$ pF	-10	0	+10	-30	0	+30	%
Drift with Temperature	$f_0 = 50$ kHz	+75	+100	+525		+200		ppm/°C
Drift with Supply Voltage	$f_0 = 50$ kHz $V_{CC} = \pm 6$ to $\pm 7$ Volts		0.1	1.0		0.2	1.5	%/V
<b>Triangle Wave</b>								
Output Voltage Level			0			0		V
Amplitude		2	2.4	3	2	2.4	3	Vp-p
Linearity			0.2			0.5		%
<b>Square Wave</b>								
Logical "1" Output Voltage	$f_0 = 50$ kHz $V_{CC} = \pm 6$ Volts	+4.9	+5.2		+4.9	+5.2		V
Logical "0" Output Voltage	$f_0 = 50$ kHz $V_{CC} = \pm 6$ Volts		-0.2	+0.2		-0.2	+0.2	V
Duty Cycle	$f_0 = 50$ kHz	45	50	55	40	50	60	%
Rise Time			20	100		20		nsec
Fall Time			50	200		50		nsec
Output Current (sink)		0.6	1		0.6	1		mA
Output Current (source)		5	10		5	10		mA
<b>DEMODULATED OUTPUT CHARACTERISTICS</b>								
Output Voltage Level	(pin 7) $V_{CC} = \pm 6$ Volts	4.25	4.5	4.75	4.0	4.5	5.0	V
Maximum Voltage Swing	(pin 7)		2			2		Vp-p
Output Voltage Swing	±10% frequency deviation	250	300		200	300		mVp-p
Total Harmonic Distortion			0.2	0.75		0.2	1.5	%
Output Impedance			3.6			3.6		kΩ
Offset Voltage $ V_6 - V_7 $ vs Temperature (drift)	$T_A = 25^\circ\text{C}$		30	100		50	200	mV
AM Rejection			50			100		μV/°C
		30	40			40		dB

**NOTES:**

1. Both input terminals (pins 2 and 3) must receive identical dc bias. This bias may range from 0 volts to -4 volts.
2. The external resistance for frequency adjustment ( $R_1$ ) must have a value between  $2k\Omega$  and  $20k\Omega$ .
3. Output voltage swings negative as input frequency increases.
4. Output not buffered.

TYPICAL PERFORMANCE CHARACTERISTICS

POWER SUPPLY CURRENT AS A FUNCTION OF SUPPLY VOLTAGE

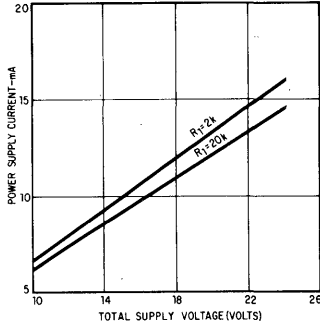

FREE-RUNNING VCO FREQ. AS A FUNCTION OF VOLTAGE BETWEEN PIN 7 & 10 (VCO CONVERSION GAIN)

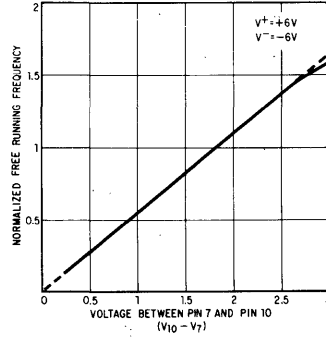

LOCK RANGE AS A FUNCTION OF INPUT VOLTAGE

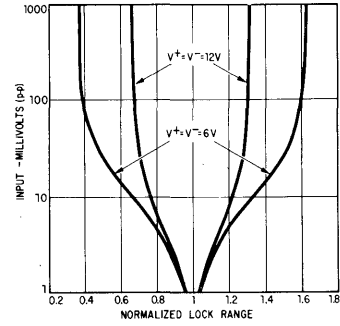

LOCK RANGE AS A FUNCTION OF GAIN SETTING RESISTANCE (PIN 6-7)

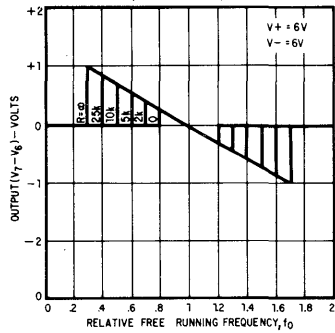

CHANGE IN FREE-RUNNING VCO FREQUENCY AS A FUNCTION OF TEMPERATURE

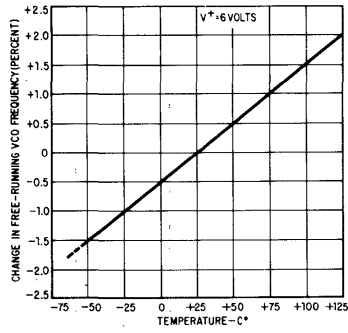

VCO OUTPUT WAVEFORM

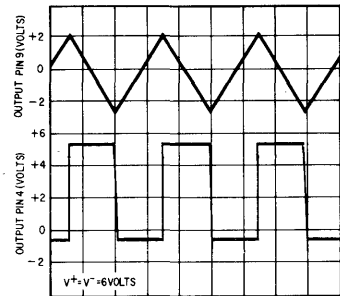

SCHEMATIC DIAGRAM

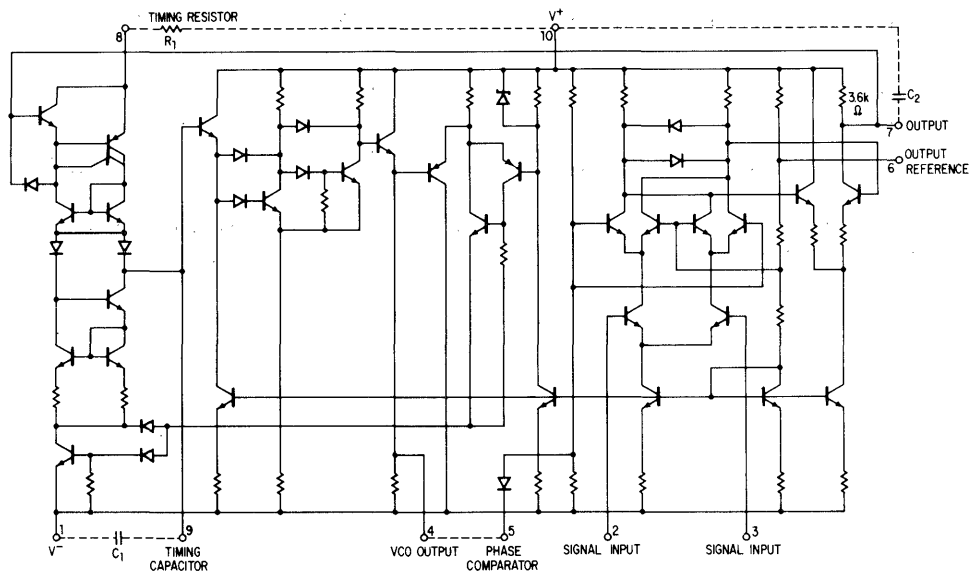

**DESIGN FORMULAS**

Free-running frequency of VCO  $f_o = \frac{1}{4R_1C_1}$  in Hz

Lock-range  $f_L = \pm \frac{8f_o}{V_{cc}}$  in Hz

Capture-range  $f_C \approx \pm \frac{1}{2\pi} \sqrt{\frac{2\pi f_L}{\tau}}$

where  $\tau = (3.6 \times 10^3) \times C_2$

**DEFINITION OF TERMS**

**FREE-RUNNING FREQUENCY ( $f_o$ )**

Frequency of VCO without input signal, both inputs grounded.

**CAPTURE-RANGE**

That range of frequencies about  $f_o$  over which the loop will acquire lock with an input signal initially starting out of lock.

**LOCK-RANGE OR TRACKING-RANGE**

That range of frequencies in the vicinity of  $f_o$  over which the VCO, once locked to the input signal, will remain locked.

**TYPICAL APPLICATIONS**

**FM DEMODULATION**

The 565 Phase Locked Loop is a general purpose circuit designed for highly-linear FM demodulation. During lock, the average dc level of the phase comparator output signal is directly proportional to the frequency of the input signal. As the input frequency shifts, it is this output signal which causes the VCO to shift its frequency to match that of the input. Consequently, the linearity of the phase comparator output with frequency is determined by the voltage-to-frequency transfer function of the VCO.

Because of its unique and highly linear VCO, the 565 PLL can lock to and track an input signal over a very wide range (typically  $\pm 60\%$ ) with very high linearity (typically, within 0.5%).

A typical connection diagram is shown in Figure 1. The VCO free-running frequency is given approximately by  $f_o = 1/4R_1C_1$ , and should be adjusted to be at the center of the input signal frequency range.  $C_1$  can be any value, but  $R_1$  should be within the range of 2000 to 20,000 ohms with an optimum value on the order of 4000 ohms. The source can be direct coupled if the dc resistances seen from pins 2 and 3 are equal and there is no dc voltage difference between the pins. A short between pins 4 and 5 connects the VCO to the phase comparator. Pin 6 provides a dc reference voltage that is close to the dc potential of the demodulated output (pin 7). Thus, if a resistance ( $R_2$  in Figure 1) is connected between pins 6 and 7, the gain of the output stage can be reduced with little change in the dc voltage level at the output. This allows the lock range to be decreased with little change in the free-running frequency. In this manner the lock range can be decreased from  $\pm 60\%$  of  $f_o$  to approximately  $\pm 20\%$  of  $f_o$  (at  $\pm 6V$ ).

A small capacitor (typically 0.001 $\mu F$ ) should be connected

between pins 7 and 8 to eliminate possible oscillation in the control current source.

A single-pole loop filter is formed by the capacitor  $C_2$ , connected between pin 7 and positive supply, and an internal resistance of approximately 3600 ohms.

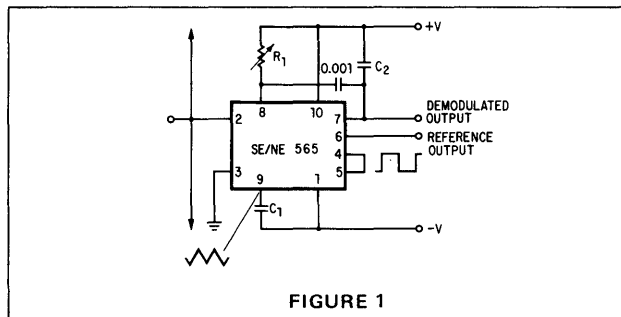

FIGURE 1

**FREQUENCY SHIFT KEYING (FSK)**

FSK refers to data transmission by means of carrier which is shifted between two preset frequencies. This frequency shift is usually accomplished by driving a VCO with the binary data signal so that the two resulting frequencies correspond to the "0" and "1" states (commonly called space and mark) of the binary data signal.

A simple scheme using the 565 to receive FSK signals of 1070 Hz and 1270 Hz is shown in Figure 2. As the signal appears at the input, the loop locks to the input frequency and tracks it between the two frequencies with a corresponding dc shift at the output.

The loop filter capacitor  $C_2$  is chosen smaller than usual to eliminate overshoot on the output pulse, and a three-stage RC ladder filter is used to remove the carrier component from the output. The band edge of the ladder filter is chosen to be approximately half way between the maximum keying rate (in this case 300 baud or 150 Hz) and twice the input frequency (approximately 2200 Hz). The output signal can now be made logic compatible by connecting a voltage comparator between the output and pin 6 of the loop. The free-running frequency is adjusted with  $R_1$  so as to result in a slightly-positive voltage at the output at  $f_{in} = 1070$  Hz.

The input connection is typical for cases where a dc voltage is present at the source and therefore a direct connection is not desirable. Both input terminals are returned to ground with identical resistors (in this case, the values are chosen to effect a 600-ohm input impedance).

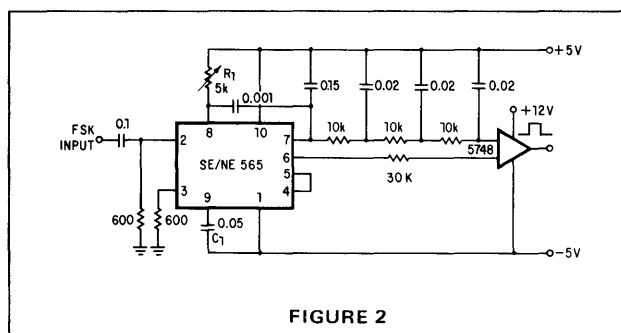

FIGURE 2

**FREQUENCY MULTIPLICATION**

There are two methods by which frequency multiplication can be achieved using the 565:

1. Locking to a harmonic of the input signal.
2. Inclusion of a digital frequency divider or counter in the loop between the VCO and phase comparator.

The first method is the simplest, and can be achieved by setting the free-running frequency of the VCO to a multiple of the input frequency. A limitation of this scheme is that the lock range decreases as successively higher and weaker harmonics are used for locking. If the input frequency is to be constant with little tracking required, the loop can generally be locked to any one of the first 5 harmonics. For higher orders of multiplication, or for cases where a large lock range is desired, the second scheme is more desirable. An example of this might be a case where the input signal varies over a wide frequency range and a large multiple of the input frequency is required.

A block diagram of the second scheme is shown in Figure 3. Here the loop is broken between the VCO and the phase comparator, and a frequency divider is inserted. The funda-

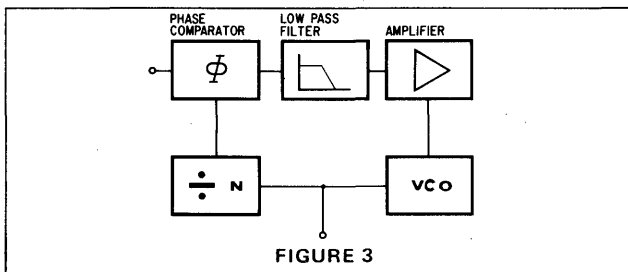

mental of the divided VCO frequency is locked to the input frequency in this case, so that the VCO is actually running at a multiple of the input frequency. The amount of multiplication is determined by the frequency divider. A typical connection scheme is shown in Figure 4. To set up the circuit, the frequency limits of the input signal must be determined. The free-running frequency of the VCO is then adjusted by means of  $R_1$  and  $C_1$  (as discussed under FM demodulation) so that the output frequency of the divider is midway between the input frequency limits. The filter capacitor,  $C_2$ , should be large enough to eliminate variations in the demodulated output voltage (at pin 7), in order to stabilize the VCO frequency. The output can now be taken as the VCO squarewave output, and its fundamental will be the desired multiple of the input frequency ( $f_1$ ) as long as the loop is in lock.

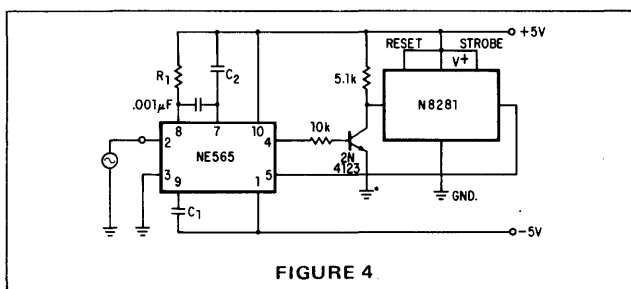

**SCA (BACKGROUND MUSIC) DECODER**

Some FM stations are authorized by the FCC to broadcast uninterrupted background music for commercial use. To do this a frequency modulated subcarrier of 67 kHz is used. The frequency is chosen so as not to interfere with the normal stereo or monaural program; in addition, the level of the subcarrier is only 10% of the amplitude of the combined signal.

The SCA signal can be filtered out and demodulated with the NE565 Phase Locked Loop without the use of any resonant circuits. A connection diagram is shown in Figure 5. This circuit also serves as an example of operation from a single power supply.

A resistive voltage divider is used to establish a bias voltage for the input (pins 2 and 3). The demodulated (multiplex) FM signal is fed to the input through a two-stage high-pass filter, both to effect capacitive coupling and to attenuate the strong signal of the regular channel. A total signal amplitude, between 80 mV and 300 mV, is required at the input. Its source should have an impedance of less than 10,000 ohms.

The Phase Locked Loop is tuned to 67 kHz with a 5000 ohm potentiometer; only approximate tuning is required, since the loop will seek the signal.

The demodulated output (pin 7) passes through a three-stage low-pass filter to provide de-emphasis and attenuate the high-frequency noise which often accompanies SCA transmission. Note that no capacitor is provided directly at pin 7; thus, the circuit is operating as a first-order loop. The demodulated output signal is in the order of 50 mV and the frequency response extends to 7 kHz.

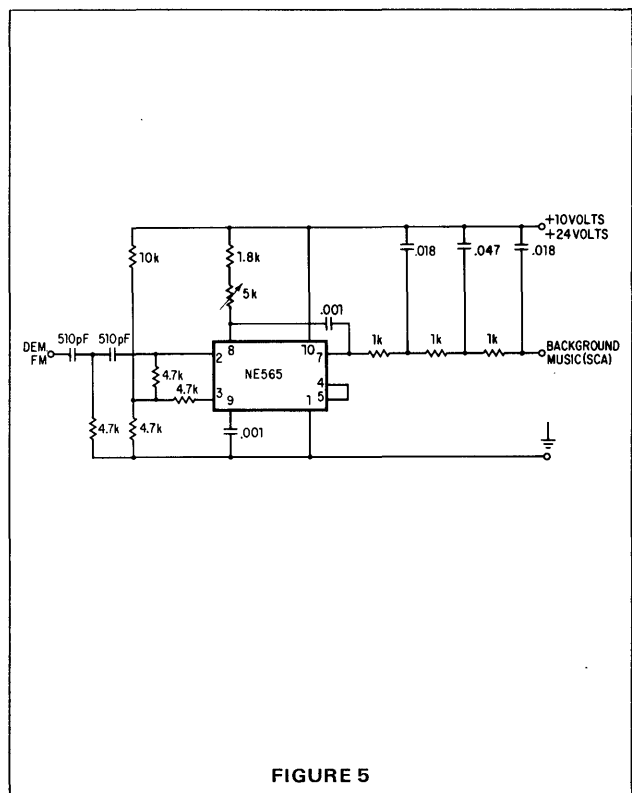



## LINEAR INTEGRATED CIRCUITS

### DESCRIPTION

The SE/NE 566 Function Generator is a voltage controlled oscillator of exceptional stability and linearity with buffered square wave and triangle wave outputs. The frequency of oscillation is determined by an external resistor and capacitor and the voltage applied to the control terminal. The oscillator can be programmed over a ten to one frequency range by proper selection of an external resistance and modulated over a ten to one range by the control voltage, with exceptional linearity.

### FEATURES

- WIDE RANGE OF OPERATING VOLTAGE (10 to 24 volts)
- VERY HIGH LINEARITY OF MODULATION
- EXTREME STABILITY OF FREQUENCY (100 ppm/°C typical)
- HIGHLY LINEAR TRIANGLE WAVE OUTPUT
- HIGH ACCURACY SQUARE WAVE OUTPUT
- FREQUENCY PROGRAMMING BY MEANS OF A RESISTOR, CAPACITOR, VOLTAGE OR CURRENT
- FREQUENCY ADJUSTABLE OVER 10 TO 1 RANGE WITH SAME CAPACITOR

### APPLICATIONS

- TONE GENERATORS
- FREQUENCY SHIFT KEYING
- FM MODULATORS
- CLOCK GENERATORS
- SIGNAL GENERATORS
- FUNCTION GENERATORS

### EQUIVALENT CIRCUIT

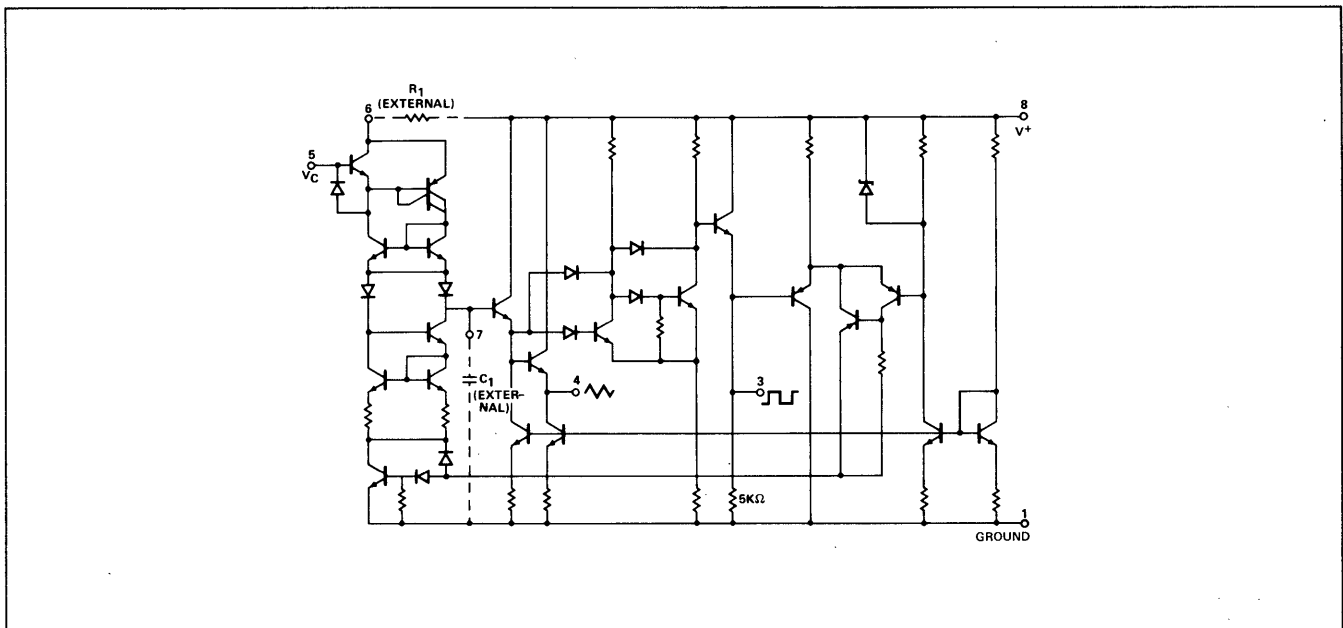

### PIN CONFIGURATION (Top View)

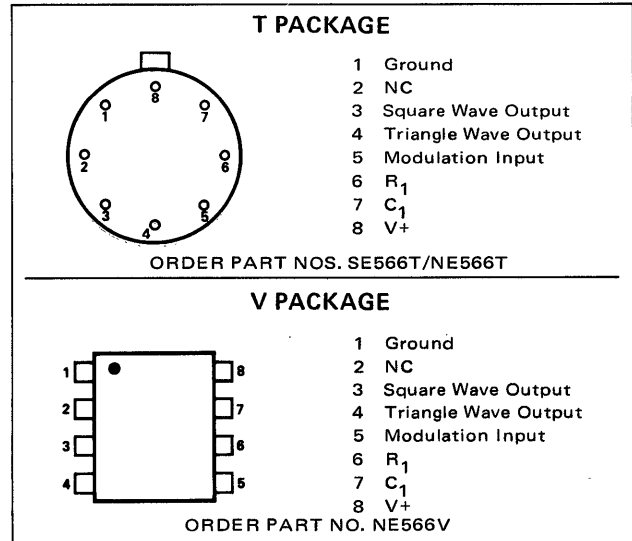

### BLOCK DIAGRAM

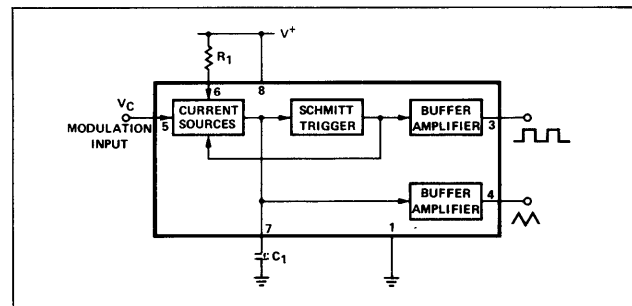



# SIGNETICS ■ SE/NE 566 – FUNCTION GENERATOR

## ABSOLUTE MAXIMUM RATINGS (Limiting values above which serviceability may be impaired)

Maximum Operating Voltage	26V
Storage Temperature	-65°C to 150°C
Power Dissipation	300mW

## ELECTRICAL CHARACTERISTICS (25°C, 12 Volts, unless otherwise stated)

CHARACTERISTICS	SE566			NE566			UNITS
	MIN.	TYP.	MAX.	MIN.	TYP.	MAX.	
<b>GENERAL</b>							
Operating Temperature Range	-55		125	0		70	°C
Operating Supply Voltage			24			24	Volts
Operating Supply Current		7	12.5		7	12.5	mA
<b>VCO (Note 1)</b>							
Maximum Operating Frequency		1			1		MHz
Frequency Drift with Temperature		100			200		ppm/°C
Frequency Drift with Supply Voltage		1			2		%/volt
Control Terminal Input Impedance (Note 2)		1			1		MΩ
FM Distortion (±10% Deviation)		0.2	0.75		0.2	1.5	%
Maximum Sweep Rate		1			1		MHz
Sweep Range		10:1			10:1		
<b>OUTPUT</b>							
<b>Triangle Wave Output -</b>							
Impedance		50			50		Ω
Voltage	2	2.4		2	2.4		Volts pp
Linearity		0.2			0.5		%
<b>Square Wave Output -</b>							
Impedance		50			50		Ω
Voltage	5	5.4		5	5.4		Volts pp
Duty Cycle	45	50	55	40	50	60	%
Rise Time		20			20		nsec
Fall Time		50			50		nsec

### NOTES:

1. The external resistance for frequency adjustment ( $R_1$ ) must have a value between  $2K\Omega$  and  $20K\Omega$ .
2. The bias voltage ( $V_C$ ) applied to the control terminal (pin 5) should be in the range  $3/4 V^+ \leq V_C \leq V^+$ .

## TYPICAL PERFORMANCE CHARACTERISTICS

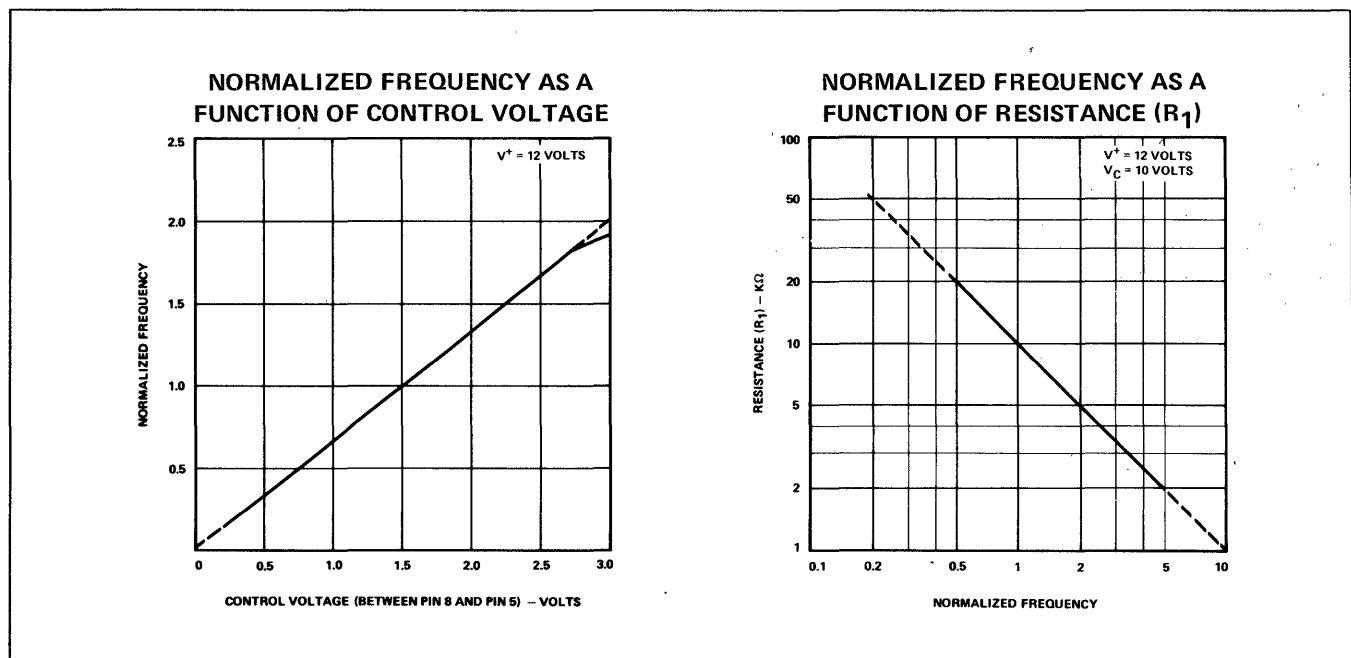

TYPICAL PERFORMANCE CHARACTERISTICS (Cont'd)

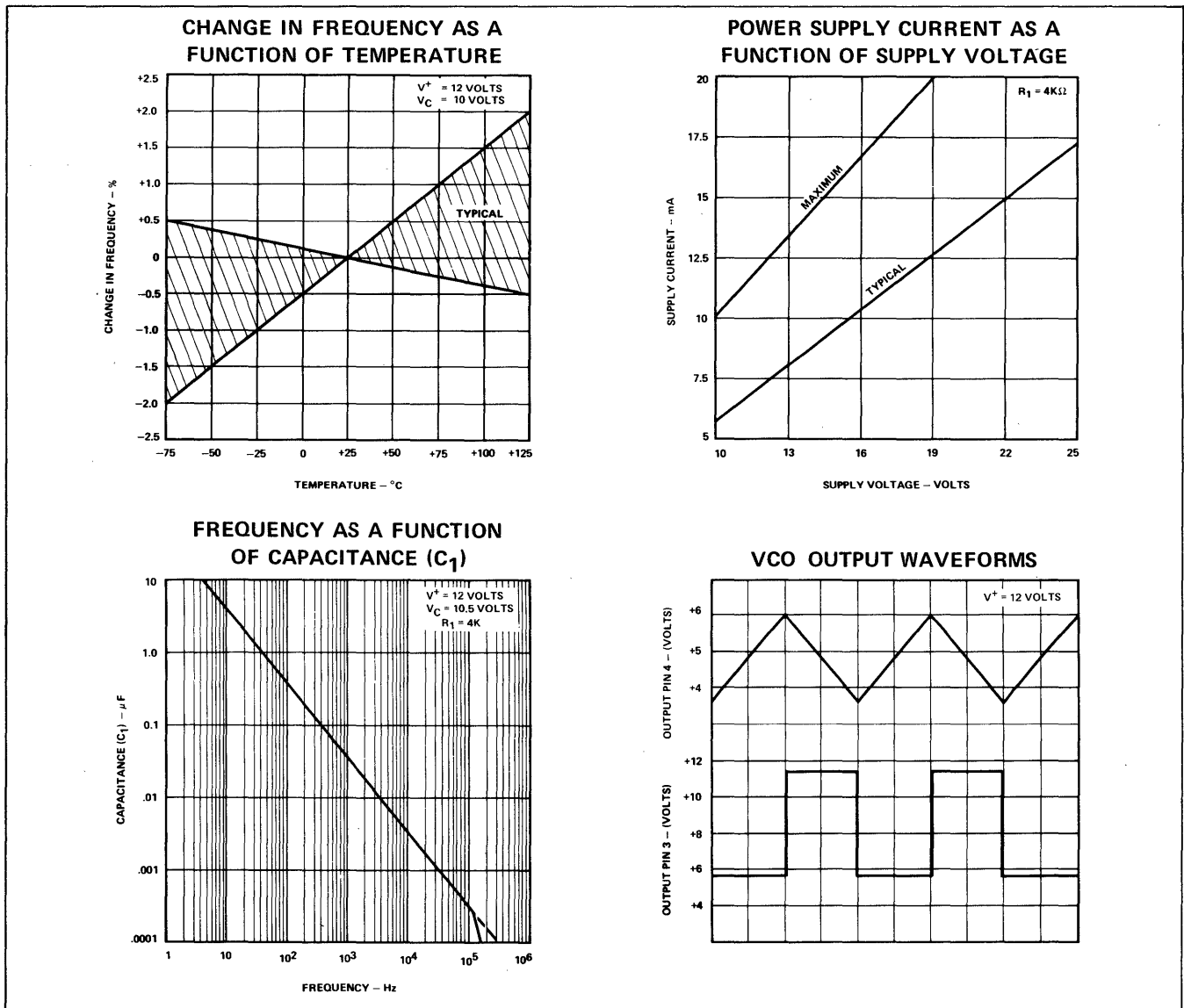

OPERATING INSTRUCTIONS

The SE/NE 566 Function Generator is a general purpose voltage controlled oscillator designed for highly linear frequency modulation. The circuit provides simultaneous square wave and triangle wave outputs at frequencies up to 1 MHz. A typical connection diagram is shown in Figure 1. The control terminal (pin 5) must be biased externally with a voltage (V<sub>C</sub>) in the range

$$3/4 V^+ \leq V_C \leq V^+$$

where V<sub>CC</sub> is the total supply voltage. In Figure 1, the control voltage is set by the voltage divider formed with R<sub>2</sub> and R<sub>3</sub>. The modulating signal is then ac coupled with the capacitor C<sub>2</sub>. The modulating signal can be direct coupled as well, if the appropriate dc bias voltage is applied to the control terminal. The frequency is given approximately by

$$f_0 \approx \frac{2(V^+ - V_C)}{R_1 C_1 V^+}$$

and R<sub>1</sub> should be in the range 2K < R<sub>1</sub> < 20KΩ. A small capacitor (typically 0.001μf) should be connected between pins 5 and 6 to eliminate possible oscillation in the control current source.

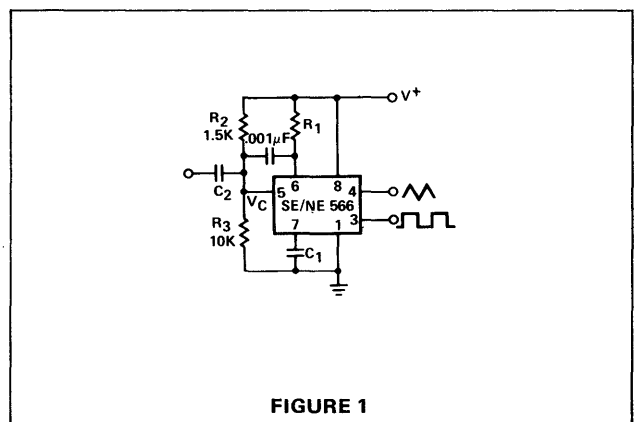

**OPERATING INSTRUCTIONS (Cont'd)**

If the VCO is to be used to drive standard logic circuitry, it may be desirable to use a dual supply of  $\pm 5$  volts as shown in Figure 2. In this case the square wave output has the proper dc levels for logic circuitry. RTL can be driven directly from pin 3. For DTL or  $T^2L$  gates, which require a current sink of more than 1 mA, it is usually necessary to connect a  $5K\Omega$  resistor between pin 3 and negative supply. This increases the current sinking capability to 2 mA. The third type of interface shown uses a saturated transistor between the 566 and the logic circuitry. This scheme is used primarily for  $T^2L$  circuitry which requires a fast fall time ( $< 50$  nsec) and a large current sinking capability.

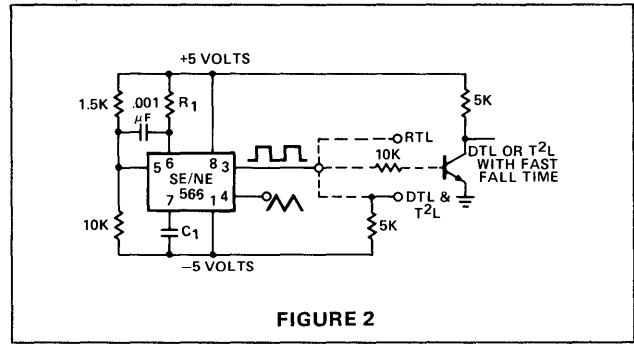

FIGURE 2

## LINEAR INTEGRATED CIRCUITS

### DESCRIPTION

The SE/NE 567 tone and frequency decoder is a highly stable phase-locked loop with synchronous AM lock detection and power output circuitry. Its primary function is to drive a load whenever a sustained frequency within its detection band is present at the self-biased input. The bandwidth center frequency, and output delay are independently determined by means of four external components.

### FEATURES

- WIDE FREQUENCY RANGE (.01Hz TO 500kHz)
- HIGH STABILITY OF CENTER FREQUENCY
- INDEPENDENTLY CONTROLLABLE BANDWIDTH (0 TO 14 PERCENT)
- HIGH OUT-BAND SIGNAL AND NOISE REJECTION
- LOGIC-COMPATIBLE OUTPUT WITH 100mA CURRENT SINKING CAPABILITY
- INHERENT IMMUNITY TO FALSE SIGNALS
- FREQUENCY ADJUSTMENT OVER A 20 TO 1 RANGE WITH AN EXTERNAL RESISTOR

### APPLICATIONS

TOUCH TONE<sup>®</sup> DECODING  
 CARRIER CURRENT REMOTE CONTROLS  
 ULTRASONIC CONTROLS (REMOTE TV, ETC.)  
 COMMUNICATIONS PAGING  
 FREQUENCY MONITORING AND CONTROL  
 WIRELESS INTERCOM  
 PRECISION OSCILLATOR

### BLOCK DIAGRAM

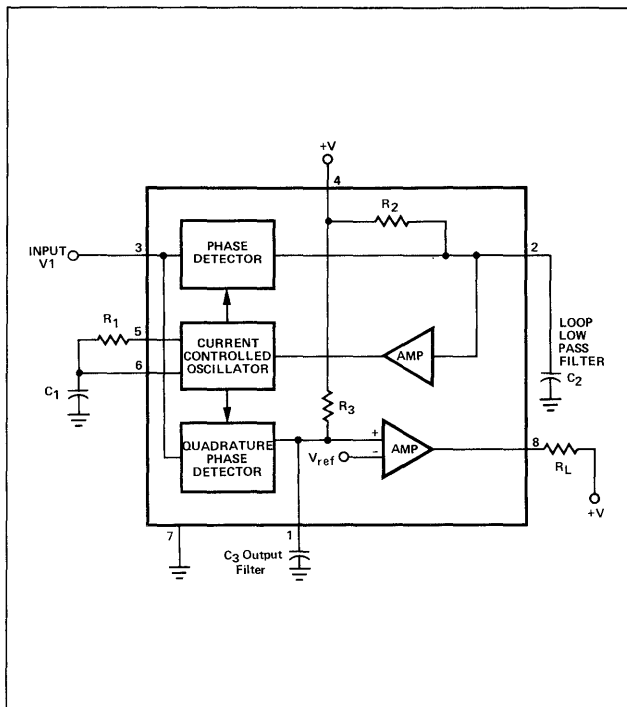

### PIN CONFIGURATION

#### T PACKAGE

(Top View)

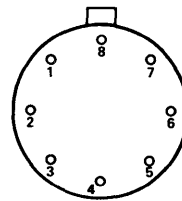

1. Output Filter Capacitor  $C_3$
2. Low Pass Filter Capacitor  $C_2$
3. Input
4. Supply Voltage +V
5. Timing Element  $R_1$
6. Timing Elements  $R_1$  and  $C_1$
7. Ground
8. Output

ORDER PART NOS. SE567T/NE567T

#### V PACKAGE

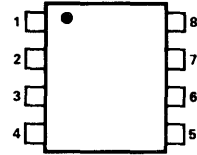

1. Output Filter Capacitor  $C_3$
2. Low Pass Filter Capacitor  $C_2$
3. Input
4. Supply Voltage +V
5. Timing Element  $R_1$
6. Timing Elements  $R_1$  and  $C_1$
7. Ground
8. Output

ORDER PART NO. NE567V

### ABSOLUTE MAXIMUM RATINGS:

Operating Temperature	0°C to 70°C NE567 -55°C to 125°C SE567
Operating Voltage	10V
Positive Voltage at Input	0.5V above Supply Voltage (Pin 4)
Negative Voltage at Input	-10 VDC
Output Voltage (collector of output transistor)	15 VDC
Storage Temperature	-65°C to 150°C
Power Dissipation	300mW

**SIGNETICS ■ 567 – TONE DECODER PHASE LOCKED LOOP**
**ELECTRICAL CHARACTERISTICS** ( $V_+ = 5.0$  Volts,  $T_A = 25^\circ\text{C}$  unless noted)

CHARACTERISTICS	SE567			NE567			UNITS	TEST CONDITIONS
	MIN	TYP	MAX	MIN	TYP	MAX		
<b>CENTER FREQUENCY(NOTE 1)</b>								
Highest Center Frequency ( $f_o$ )	100	500		100	500		kHz	
Center Frequency Stability (Note 2)		35±140 35±60			35±140 35±60		ppm/ $^\circ\text{C}$ ppm/ $^\circ\text{C}$	-55 to 125 $^\circ\text{C}$ 0 to 70 $^\circ\text{C}$
Center Frequency Shift with Supply Voltage		0.5	1		0.7	2	%/Volt	$f_o = 100\text{KHz}$
<b>DETECTION BANDWIDTH</b>								
Largest Detection Bandwidth	12	14	16	10	14	18	% of $f_o$	$f_o = 100\text{KHz}$
Largest Detection Bandwidth Skew		1	2		2	3	% of $f_o$	
Largest Detection Bandwidth - Variation with Temperature		±0.1			±0.1		%/ $^\circ\text{C}$	$V_i = 300\text{mVrms}$
Largest Detection Bandwidth - Variation with Supply Voltage		±2			±2		%/Volt	$V_i = 300\text{mVrms}$
<b>INPUT</b>								
Input Resistance		20			20		K $\Omega$	
Smallest Detectable Input Voltage( $V_i$ )		20	25		20	25	mV rms	$I_L = 100\text{mA}$ , $f_i = f_o$
Largest No-Output Input Voltage	10	15		10	15		mV rms	$I_L = 100\text{mA}$ , $f_i = f_o$
Greatest Simultaneous Outband Signal to Inband Signal Ratio		+6			+6		dB	
Minimum Input Signal to Wideband Noise Ratio		-6			-6		dB	$B_n = 140\text{KHz}$
<b>OUTPUT</b>								
Fastest On-Off Cycling Rate		$f_o/20$			$f_o/20$			
"1" Output Leakage Current		0.01	25		0.01	25	$\mu\text{A}$	
"0" Output Voltage		0.2 0.6	0.4 1.0		0.2 0.6	0.4 1.0	Volt Volt	$I_L = 30\text{mA}$ $I_L = 100\text{mA}$
Output Fall Time (Note 3)		30			30		n sec	$R_L = 50\Omega$
Output Rise Time (Note 3)		150			150		n sec	$R_L = 50\Omega$
<b>GENERAL</b>								
Operating Voltage Range	4.75		9.0	4.75		9.0	Volts	
Supply Current - Quiescent		6	8		7	10	mA	
Supply Current - Activated		11	13		12	15	mA	$R_L = 20\text{K}\Omega$
Quiescent Power Dissipation		30			35		mW	

**NOTES:**

1. Frequency determining resistor  $R_1$  should be between 1 and 20K $\Omega$ .
2. Applicable over 4.75 to 5.75 volts. See graphs for more detailed information.
3. Pin 8 to Pin 1 feedback  $R_L$  network selected to eliminate pulsing during turn-on and turn-off.

TYPICAL CHARACTERISTIC CURVES

**BANDWIDTH VERSUS INPUT SIGNAL AMPLITUDE**

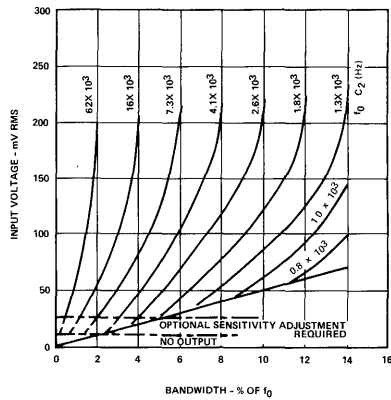

**LARGEST DETECTION BANDWIDTH VERSUS OPERATING FREQUENCY**

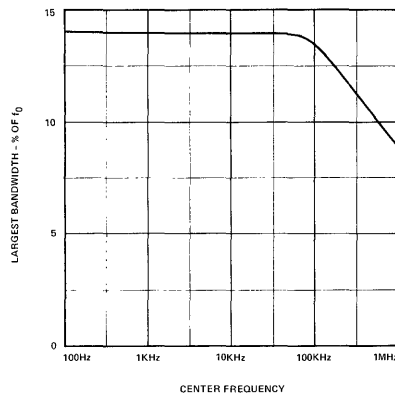

**DETECTION BANDWIDTH AS A FUNCTION OF  $C_2$  AND  $C_3$**

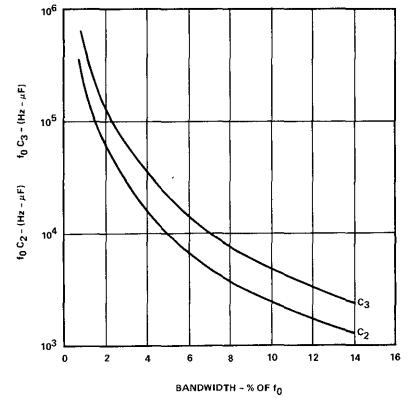

**TYPICAL SUPPLY CURRENT VERSUS SUPPLY VOLTAGE**

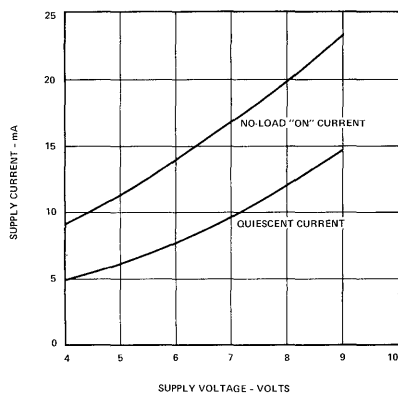

**GREATEST NUMBER OF CYCLES BEFORE OUTPUT**

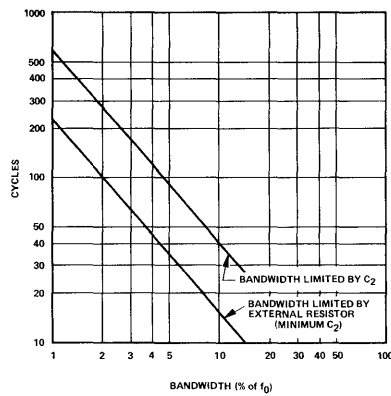

**TYPICAL OUTPUT VOLTAGE VERSUS TEMPERATURE**

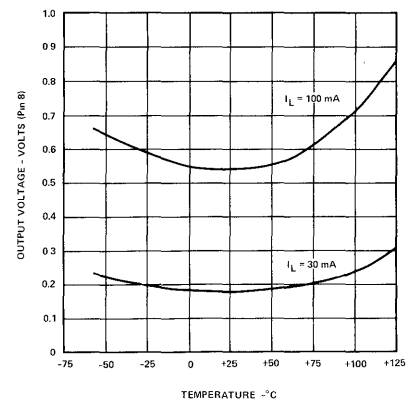

**CENTER FREQUENCY COEFFICIENT TEMPERATURE (MEAN AND S.D.)**

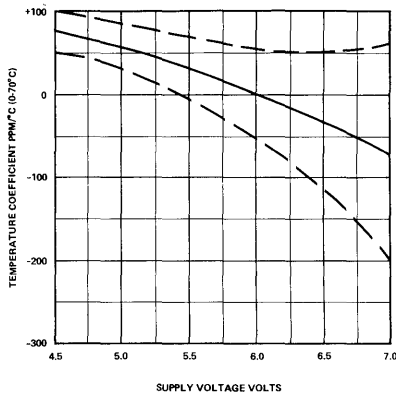

**TYPICAL FREQUENCY DRIFT WITH TEMPERATURE (MEAN AND S.D.)**

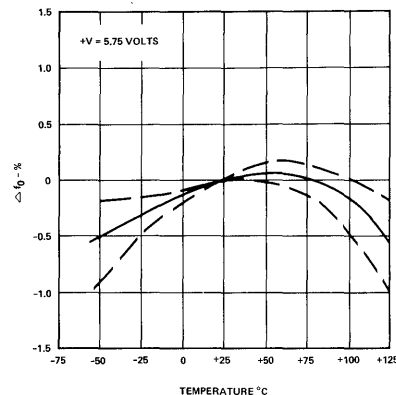

**TYPICAL BANDWIDTH VARIATION WITH TEMPERATURE**

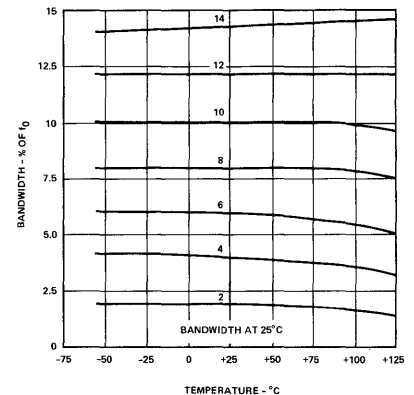

TYPICAL CHARACTERISTIC CURVES (Cont'd.)

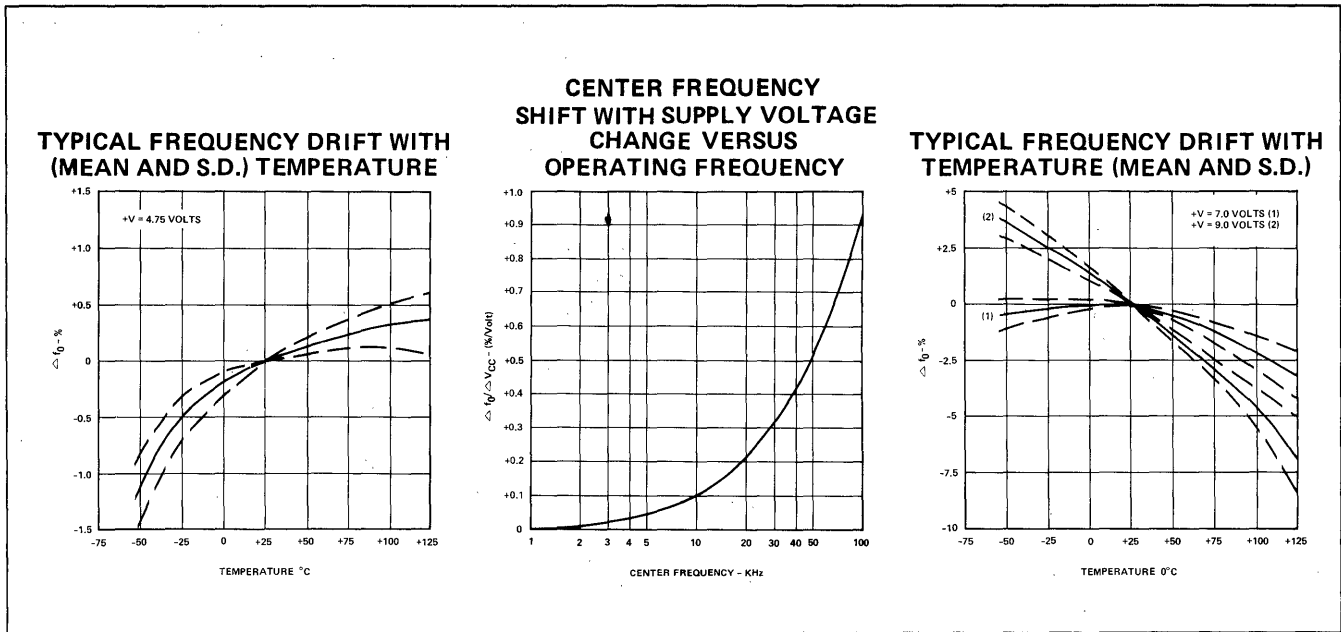

SCHEMATIC DIAGRAM

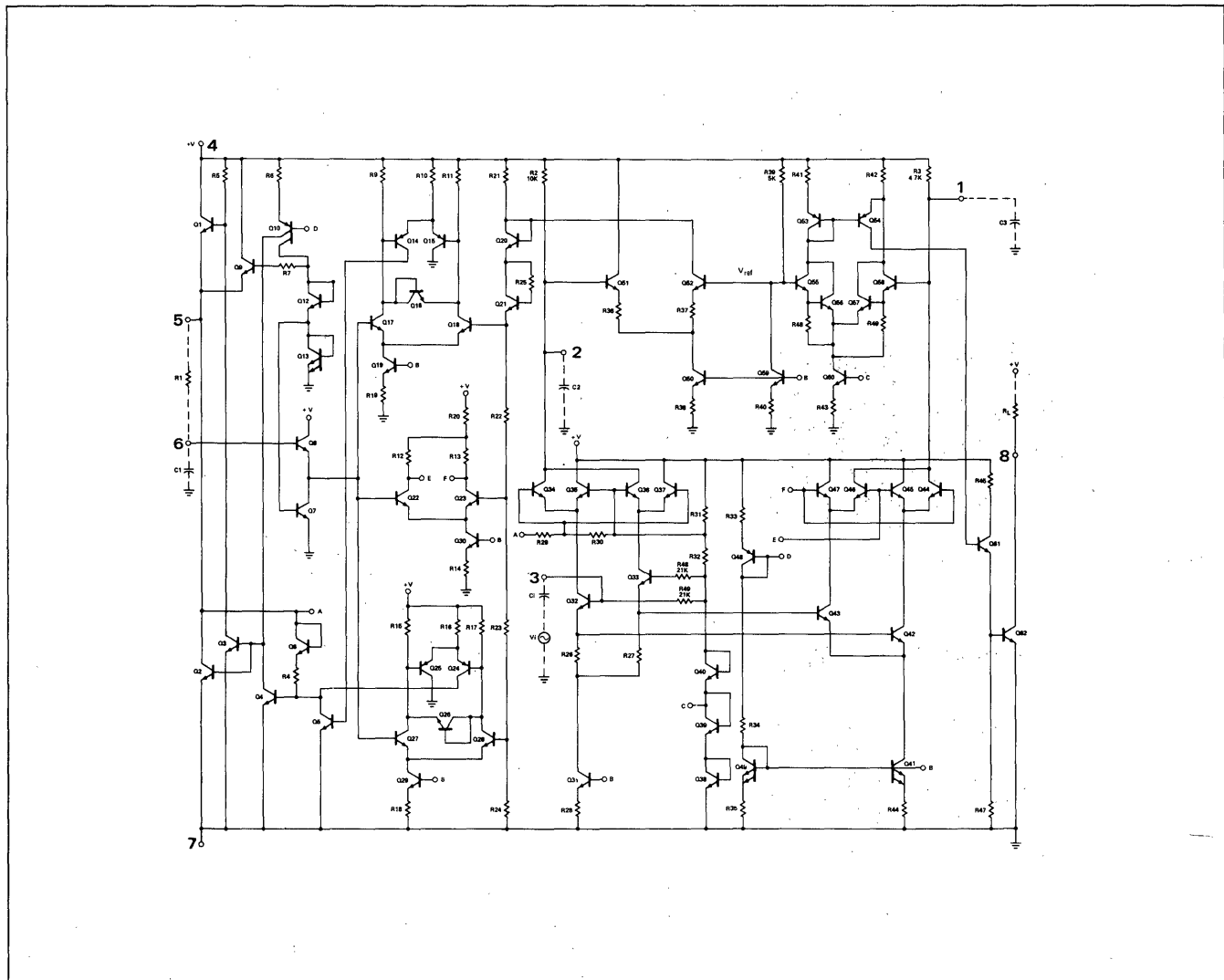

**DESIGN FORMULAS**

$$f_0 \approx \frac{1}{R_1 C_1}$$

$$BW \approx 1070 \sqrt{\frac{V_i}{f_0 C_2}} \text{ in \% of } f_0$$

Where

$V_i$  = Input Voltage (Volts )

$C_2$  = Low-Pass Filter Capacitor ( $\mu$ F)

**PHASE LOCKED LOOP TERMINOLOGY**  
**CENTER FREQUENCY ( $f_0$ )**

The free-running frequency of the current controlled oscillator (CCO) in the absence of an input signal.

**DETECTION BANDWIDTH (BW)**

The frequency range, centered about  $f_0$ , within which an input signal above the threshold voltage (typically 20mV rms) will cause a logical zero state on the output. The detection bandwidth corresponds to the loop capture range.

**LARGEST DETECTION BANDWIDTH**

The largest frequency range within which an input signal above the threshold voltage will cause a logical zero state on the output. The maximum detection bandwidth corresponds to the loop lock range.

**DETECTION BAND SKEW**

A measure of how well the largest detection band is centered about the center frequency,  $f_0$ . The skew is defined as  $(f_{max} + f_{min} - 2f_0)/f_0$  where  $f_{max}$  and  $f_{min}$  are the frequencies corresponding to the edges of the detection band. The skew can be reduced to zero if necessary by means of an optional centering adjustment.

**TYPICAL RESPONSE**

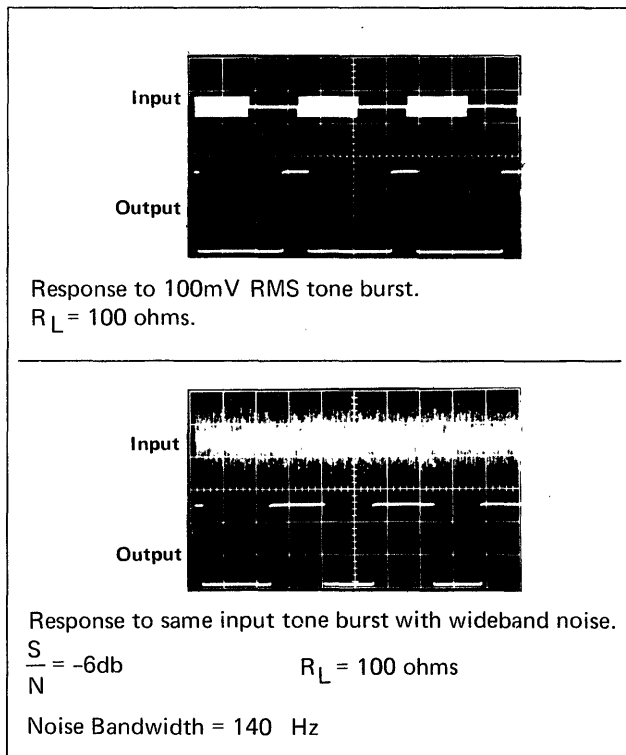

**OPERATING INSTRUCTIONS**

Figure 1 shows a typical connection diagram for the 567. For most applications, the following three-step procedure will be sufficient for choosing the external components  $R_1$ ,  $C_1$ ,  $C_2$  and  $C_3$ .

1. Select  $R_1$  and  $C_1$  for the desired center frequency ( $f_0 \approx 1/R_1 C_1$ ). For best temperature stability,  $R_1$  should be between 2 and 20 ohm, and the  $R_1 C_1$  product should have sufficient stability, over the projected temperature range to meet the necessary requirements.

2. Select the low-pass capacitor,  $C_2$ , by referring to the Bandwidth versus Input Signal Amplitude graph. If the input amplitude variation is known, the appropriate value of  $f_0 C_2$  necessary to give the desired bandwidth may be found. Conversely, an area of operation may be selected on this graph and the input level and  $C_2$  may be adjusted accordingly. For example, constant bandwidth operation requires that input amplitude be above 200mVrms. The bandwidth, as noted on the graph, is then controlled solely by the  $f_0 C_2$  product.

3. The value of  $C_3$  is generally non-critical.  $C_3$  sets the band edge of a low pass filter which attenuates frequencies outside the detection band to eliminate spurious outputs. If  $C_3$  is too small, frequencies just outside the detection band will switch the output stage on and off at the beat frequency, or the output may pulse on and off during the turn-on transient. If  $C_3$  is too large, turn-on and turn-off of the output stage will be delayed until the voltage on  $C_3$  passes the threshold voltage. (Such a delay may be desirable to avoid spurious outputs due to transient frequencies.) A typical minimum value for  $C_3$  is  $2C_2$ .

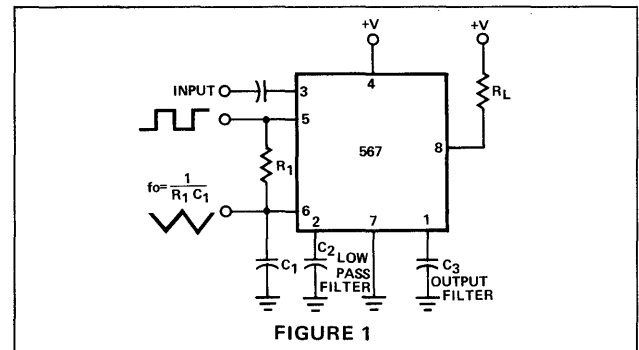

**AVAILABLE OUTPUTS** (Figure 2)

The primary output is the uncommitted output transistor collector, pin 8. When an in-band input signal is present, this transistor saturates; its collector voltage being less than 1.0 volt (typically 0.6V) at full output current (100mA). The voltage at pin 2 is the phase detector output, a linear function of frequency, over the range of 0.95 to 1.05  $f_0$ , with a slope of about 20mV/% frequency deviation. The average voltage at pin 1 is, during lock, a function of the in-band input amplitude in accordance with the transfer characteristic given. Pin 5 is the controlled oscillator square wave output of magnitude  $(V^+ - 2V_{be}) \approx (V^+ - 1.4V)$  having a dc average of  $V^+/2$ . A 1K $\Omega$  load may be driven from pin 5. Pin 6 is an exponential triangle of 1 volt peak-to-peak



**AVAILABLE OUTPUTS (Cont'd.)**

with an average dc level of  $V^+ / 2$ . Only high impedance loads may be connected to pin 6 without affecting the CCO duty cycle or temperature stability.

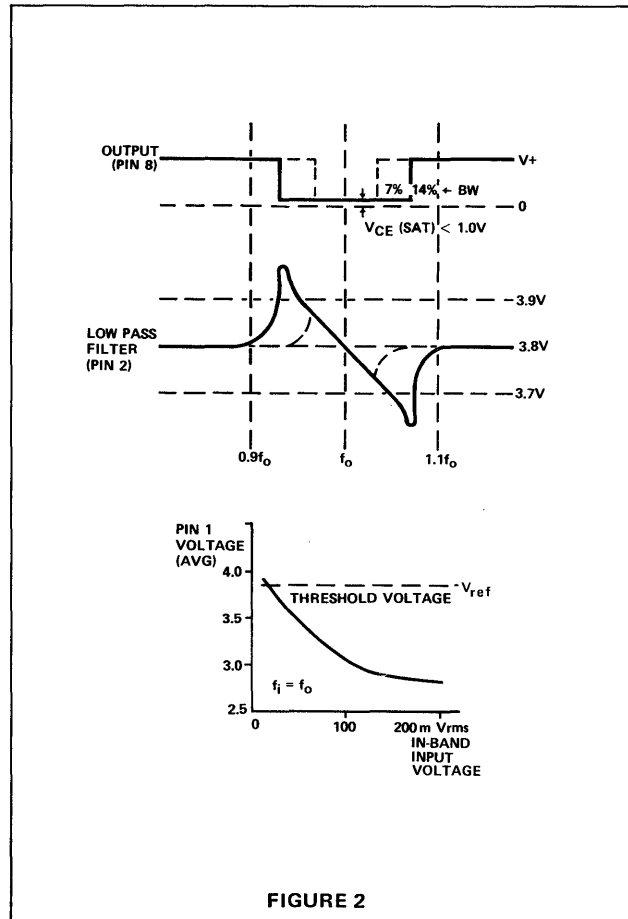

FIGURE 2

**OPERATING PRECAUTIONS**

A brief review of the following precautions will help the user attain the high level of performance of which the 567 is capable.

1. Operation in the high input level mode (above 200mV) will free the user from bandwidth variations due to changes in the in-band signal amplitude. The input stage is now limiting, however, so that out-band signals or high noise levels can cause an apparent bandwidth reduction as the in band signal is suppressed. Also, the limiting action will create in-band components from sub-harmonic signals, so the 567 becomes sensitive to signals at  $f_0/3$ ,  $f_0/5$ , etc.
2. The 567 will lock onto signals near  $(2n+1) f_0$ , and will give an output for signals near  $(4n+1) f_0$  where  $n = 0, 1, 2$ , etc. Thus, signals at  $5 f_0$  and  $9 f_0$  can cause an unwanted output. If such signals are anticipated, they should be attenuated before reaching the 567 input.
3. Maximum immunity from noise and out-band signals is afforded in the low input level (Below 200mVrms) and reduced bandwidth operating mode. However, decreased loop damping causes the worst-case lock-up time to increase, as shown by the Greatest Number of Cycles Before Output vs. Bandwidth graph.

4. Due to the high switching speeds (20ns) associated with 567 operation, care should be taken in lead routing. Lead lengths should be kept to a minimum. The power supply should be adequately bypassed close to the 567 with an  $0.01\mu F$  or greater capacitor; grounding paths should be carefully chosen to avoid ground loops and unwanted voltage variations. Another factor which must be considered is the effect of load energization on the power supply. For example, an incandescent lamp typically draws 10 times rated current at turn-on. This can cause supply voltage fluctuations which could, for example, shift the detection band of narrow-band systems sufficiently to cause momentary loss of lock. The result is a low-frequency oscillation into and out of lock. Such effects can be prevented by supplying heavy load currents from a separate supply, or increasing the supply filter capacitor.

**SPEED OF OPERATION**

Minimum lock-up time is related to the natural frequency of the loop. The lower it is, the longer becomes the turn-on transient. Thus, maximum operating speed is obtained when  $C_2$  is at a minimum. When the signal is first applied, the phase may be such as to initially drive the controlled oscillator away from the incoming frequency rather than toward it. Under this condition, which is of course unpredictable, the lock-up transient is at its worst and the theoretical minimum lock-up time is not achievable. We must simply wait for the transient to die out.

The following expressions give the values of  $C_2$  and  $C_3$  which allow highest operating speeds for various band center frequencies. The minimum rate at which digital information may be detected without information loss due to the turn-on transient or output chatter is about 10 cycles per bit, corresponding to an information transfer rate of  $f_0/10$  baud.

$$C_2 = \frac{130}{f_0} \mu F$$

$$C_3 = \frac{260}{f_0} \mu F$$

in cases where turn-off time can be sacrificed to achieve fast turn-on, the optional sensitivity adjustment circuit can be used to move the quiescent  $C_3$  voltage lower (closer to the threshold voltage). However, sensitivity to beat frequencies, noise and extraneous signals will be increased.

**OPTIONAL CONTROLS**

The 567 has been designed so that, for most applications, no external adjustments are required. Certain applications, however, will be greatly facilitated if full advantage is taken of the added control possibilities available through the use of additional external components. In the diagrams given, typical values are suggested where applicable. For best results resistors used, except where noted, should have the same temperature coefficient. Ideally, silicon diodes would be low-resistivity types, such as forward-biased low-voltage zeners or forward-biased transistor base-emitter junctions. However, ordinary low-voltage diodes should be adequate for most applications.

**SENSITIVITY ADJUSTMENT**

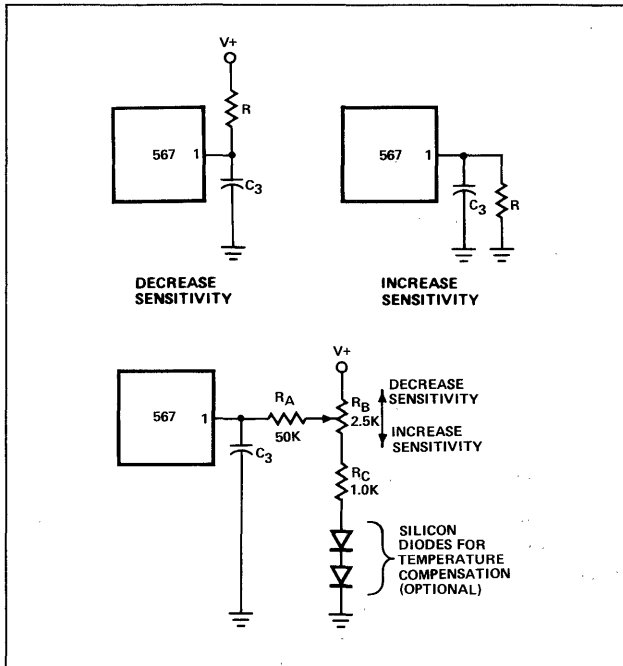

When operated as a very narrow band detector (less than 8 percent), both  $C_2$  and  $C_3$  are made quite large in order to improve noise and outband signal rejection. This will inevitably slow the response time. If, however, the output stage is biased closer to the threshold level, the turn-on time can be improved. This is accomplished by drawing additional current to terminal 1. Under this condition, the 567 will also give an output for lower-level signals (10m or lower).

By adding current to terminal 1, the output stage is biased further away from the threshold voltage. This is most useful when, to obtain maximum operating speed,  $C_2$  and  $C_3$  are made very small. Normally, frequencies just outside the detection band could cause false outputs under this condition. By desensitizing the output stage, the outband beat notes do not feed through to the output stage. Since the input level must be somewhat greater when the output stage is made less sensitive, rejection of third harmonics or in-band harmonics (of lower frequency signals) is also improved.

**CHATTER PREVENTION**

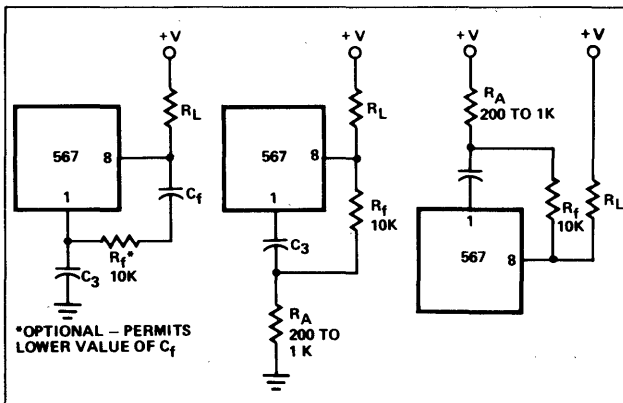

Chatter occurs in the output stage when  $C_3$  is relatively small, so that the lock transient and the AC components at the quadrature phase detector (lock detector) output cause the output stage to move through its threshold more than once. Many loads, for example lamps and relays, will not respond to the chatter. However, logic may recognize the chatter as a series of outputs. By feeding the output stage output back to its input, (pin 1) the chatter can be eliminated. Three schemes for doing this are given above. All operate by feeding the first output step (either on or off) back to the input, pushing the input past the threshold until the transient conditions are over. It is only necessary to assure that the feedback time constant is not so large as to prevent operation at the highest anticipated speed. Although chatter can always be eliminated by making  $C_3$  large, the feedback circuit will enable faster operation of the 567 by allowing  $C_3$  to be kept small. Note that if the feedback time constant is made quite large, a short burst at the input frequency can be stretched into a long output pulse. This may be useful to drive, for example, stepping relays.

**DETECTION BAND CENTERING (OR SKEW) ADJUSTMENT**

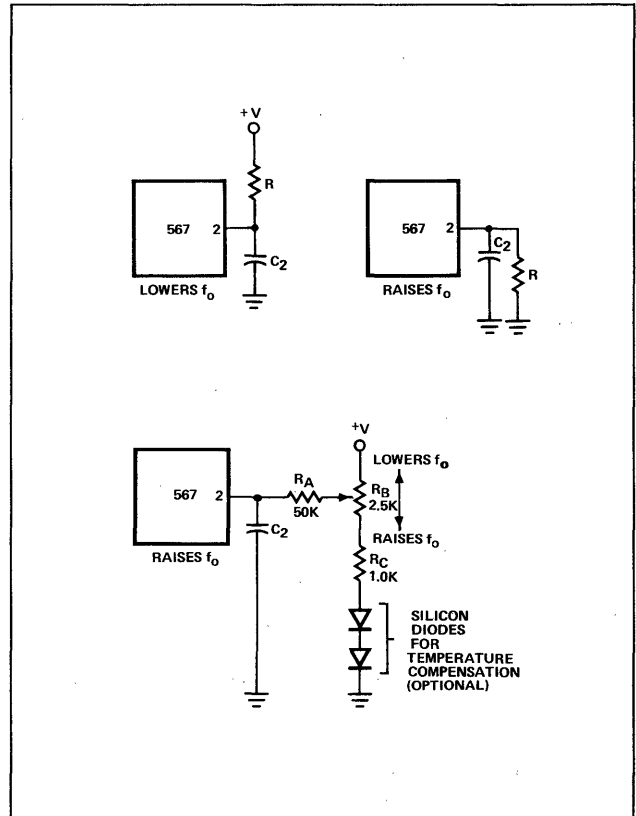

When it is desired to alter the location of the detection band (corresponding to the loop capture range) within the largest detection band (lock range), the circuits shown above can be used. By moving the detection band to one edge of the range, for example, input signal variations will expand the detection band in only one direction. This may prove useful when a strong but undesirable signal is expected on one side or the other of the center frequency. Since  $R_B$  also alters the duty cycle slightly, this method may be used to obtain a precise duty cycle when the 567 is used as an oscillator.

ALTERNATE METHOD OF BANDWIDTH REDUCTION

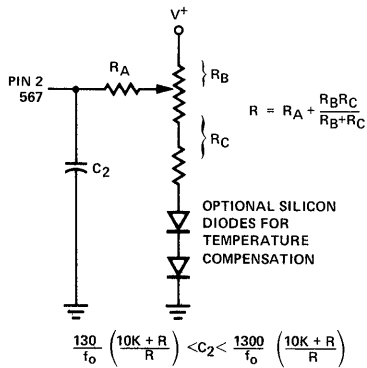
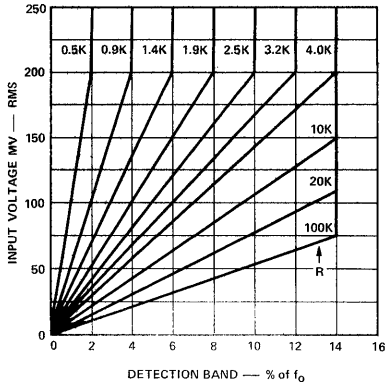

NOTE: Adjust control for symmetry of detection band edges about  $f_0$ .

Although a large value of  $C_2$  will reduce the bandwidth, it also reduces the loop damping so as to slow the circuit response time. This may be undesirable. Bandwidth can be reduced by reducing the loop gain. This scheme will improve damping and permit faster operation under narrow-band operation. Note that the reduced impedance level at terminal 2 will require that a larger value of  $C_2$  be used for a given filter cutoff frequency. If more than three 567s are to be used, the  $R_B$ ,  $R_C$  network can be eliminated and the  $R_A$  resistors connected together. A capacitor between this junction and ground may be required to shunt high frequency components.

OUTPUT LATCHING

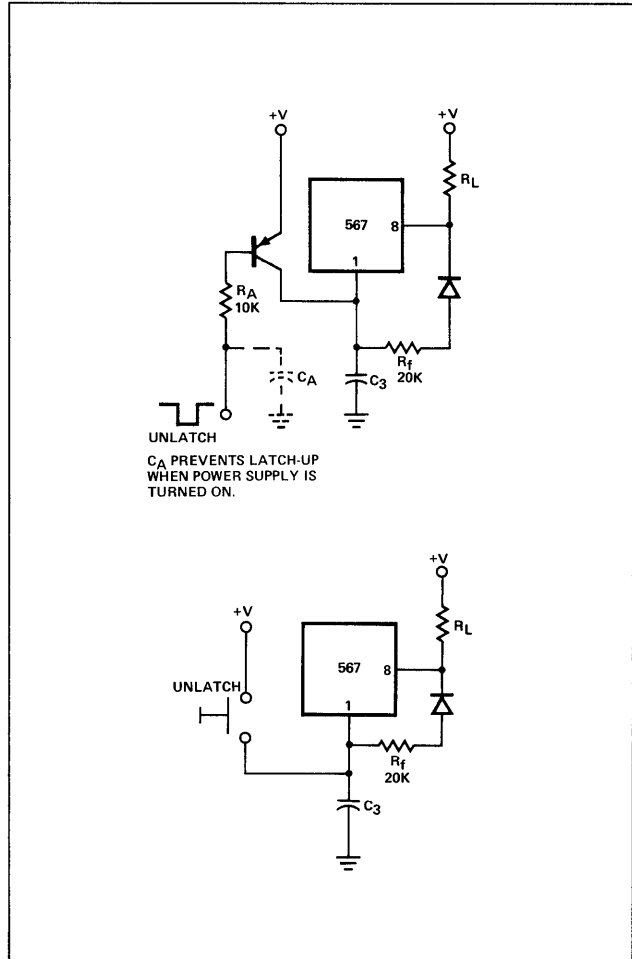

To latch the output on after a signal is received, it is necessary to provide a feedback resistor around the output stage (between pins 8 and 1). Pin 1 is pulled up to unlatch the output stage.

REDUCTION OF  $C_1$  VALUE

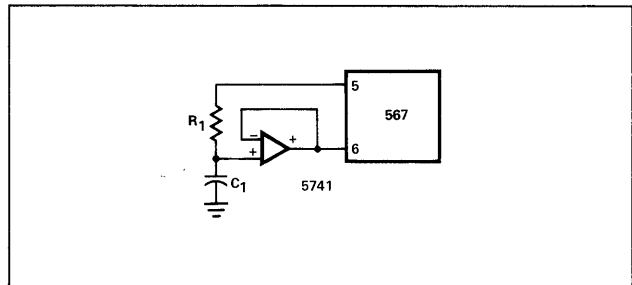

For precision, very low-frequency applications, where the value of  $C_1$  becomes large, an overall cost savings may be achieved by inserting a voltage follower between the  $R_1$   $C_1$  junction and pin 6, so as to allow a higher value of  $R_1$  and a lower value of  $C_1$  for a given frequency.

PROGRAMMING

To change the center frequency, the value of  $R_1$  can be changed with a mechanical or solid state switch, or additional  $C_1$  capacitors may be added by grounding them through saturating npn transistors.

TYPICAL APPLICATIONS

CARRIER-CURRENT REMOTE CONTROL OR INTERCOM

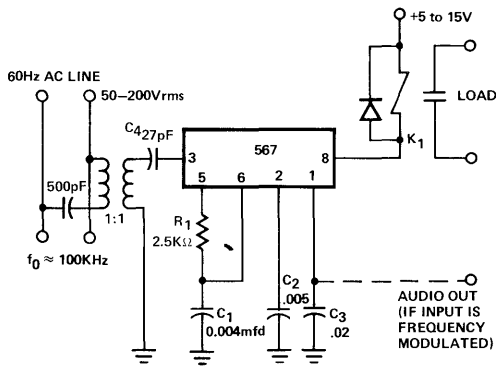

DUAL-TONE DECODER

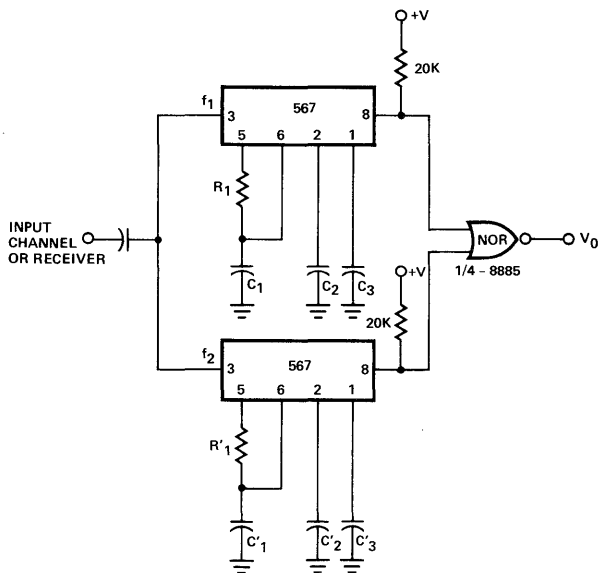

1. Resistor and capacitor values chosen for desired frequencies and bandwidth.
2. If  $C_3$  is made large so as to delay turn-on of the top 567, decoding of sequential ( $f_1, f_2$ ) tones is possible.

TOUCH-TONE<sup>®</sup> DECODER

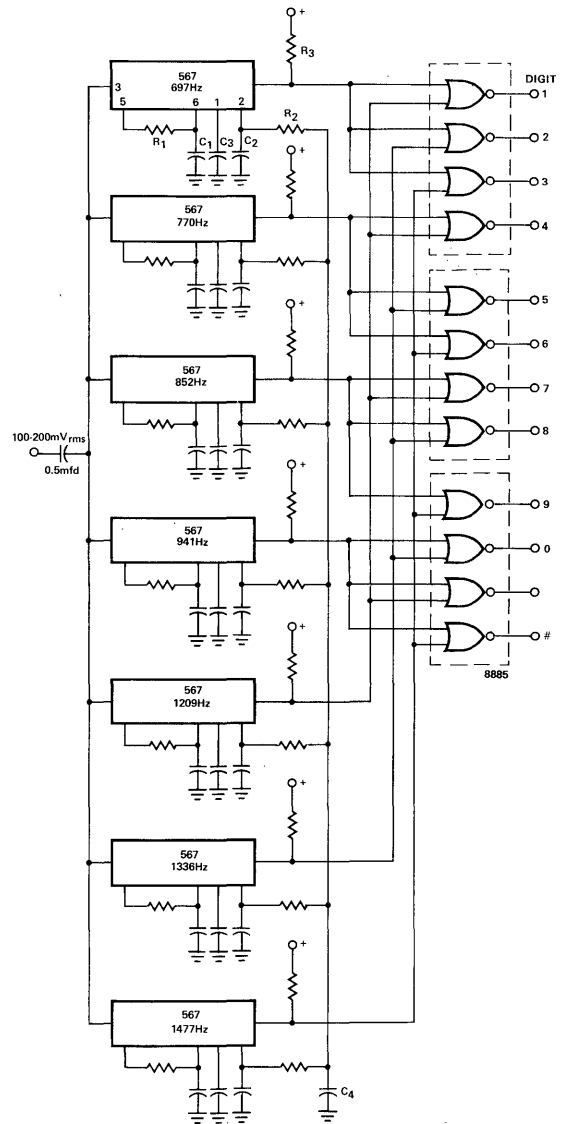

Component Values (Typical)

- $R_1$  6.8 to 15K ohm
- $R_2$  4.7K ohm
- $R_3$  20K ohm
- $C_1$  0.10 mfd
- $C_2$  1.0 mfd 6V
- $C_3$  2.2mfd 6V
- $C_4$  250 6V

TYPICAL APPLICATIONS (Cont'd.)

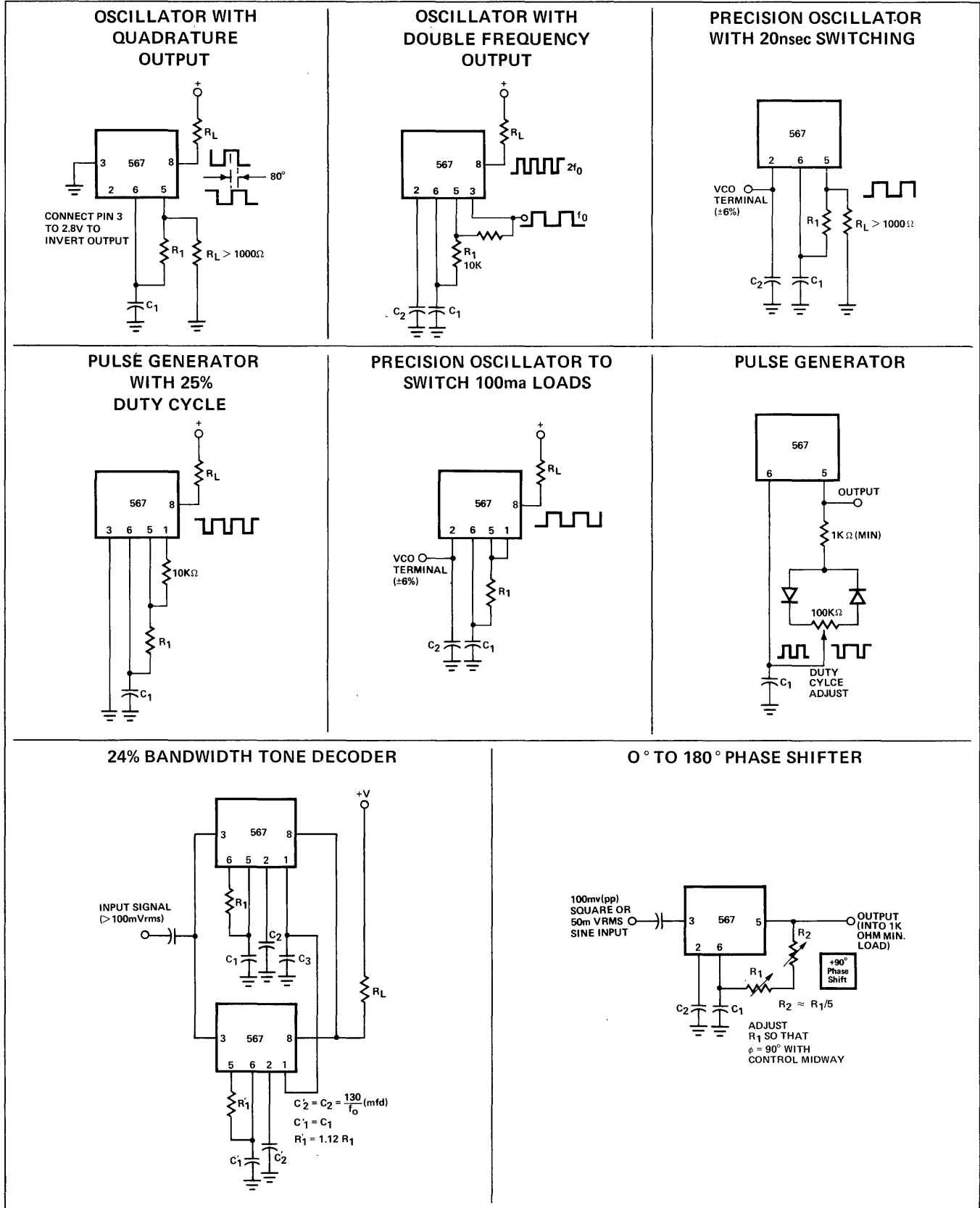

# SECTION 9

## definition of terms



**OP AMPS**

**AVERAGE INPUT OFFSET CURRENT  $t^{\circ}$  COEFF** – The change in input offset current divided by the change in ambient temperature producing it.

**AVERAGE INPUT OFFSET VOLTAGE  $t^{\circ}$  COEFF** – The change in input offset voltage divided by the change in ambient temperature producing it.

**COMMON MODE INPUT RESISTANCE** – The resistance looking into both inputs tied together.

**COMMON MODE REJECTION RATIO (CMRR)** – The ratio of the change of input offset voltage to the input common mode voltage change producing it.

**FULL POWER BANDWIDTH** – The maximum frequency at which the full sinewave output might be obtained.

**INPUT BIAS CURRENT** – The average of the two input currents at zero output voltage. In some cases, the input current for either input independently.

**INPUT CAPACITANCE** – The capacitance looking into either input terminal with the other grounded.

**INPUT CURRENT** – The current into an input terminal.

**INPUT NOISE VOLTAGE** – The square root of the mean square narrow-band noise voltage referred to the input.

**INPUT OFFSET CURRENT** – The difference in the currents into the two input terminals with the output at zero volts.

**INPUT OFFSET VOLTAGE** – That voltage which must be applied between the input terminals to obtain zero output voltage. The input offset voltage may also be defined for the case where two equal resistances are inserted in series with the input leads.

**INPUT RESISTANCE** – The resistance looking into either input terminal with the other grounded.

**INPUT VOLTAGE RANGE** – The range of voltages on the input terminals for which the amplifier operates within specifications. In some cases, the input offset specifications apply over the input voltage range.

**LARGE-SIGNAL VOLTAGE GAIN** – The ratio of the maximum output voltage swing to the change in input voltage required to drive the output to this voltage.

**OUTPUT RESISTANCE** – The resistance seen looking into the output terminal with the output at null. This parameter is defined only under small signal conditions at frequencies above a few hundred cycles to eliminate the influence of drift and thermal feedback.

**OUTPUT SHORT-CIRCUIT CURRENT** – The maximum output current available from the amplifier with the output shorted to ground or to either supply.

**OUTPUT VOLTAGE SWING** – The peak output swing, referred to zero, that can be obtained.

**POWER CONSUMPTION** – The DC power required to operate the amplifier with the output at zero and with no load current.

**POWER SUPPLY REJECTION RATIO** – The ratio of the change in input offset voltage to the change in supply voltages producing it.

**RISE TIME** – The time required for an output voltage step to change from 10% to 90% of its final value.

**SLEW RATE** – The maximum rate of change of output voltage under large signal condition.

**SUPPLY CURRENT** – The current required from the power supply to operate the amplifier with no load and the output at zero.

**TEMPERATURE STABILITY OF VOLTAGE GAIN** – The maximum variation of the voltage gain over the specified temperature range.

**REGULATORS**

**DROPOUT VOLTAGE** – The input-output voltage differential at which the circuit ceases to regulate against further reductions in input voltage.

**INPUT-OUTPUT VOLTAGE DIFFERENTIAL** – The range of voltage difference between the supply voltage and the regulated output voltage over which the regulator will operate.

**LINE REGULATOR** – The percentage change in output voltage for a specified change in input voltage.

**LOAD REGULATOR** – The percentage change in output voltage for a specified change in load current.

**MAXIMUM POWER DISSIPATION** – The maximum total device dissipation for which the regulator will operate within specifications.

**OUTPUT NOISE VOLTAGE** – The rms output noise voltage with constant load and no input ripple.

**OUTPUT VOLTAGE RANGE** – The range of output voltage over which the regulator will operate.

**QUIESCENT CURRENT** – That part of input current to the regulator that is not delivered to the load.



## SIGNETICS ■ DEFINITION OF TERMS

---

### REGULATORS (Cont'd.)

**REFERENCE VOLTAGE** — The output of the reference amplifier measured with respect to the negative supply.

**RIPPLE REJECTION** — The ratio of the peak-to-peak input ripple voltage to the peak-to-peak output ripple voltage.

**SENSE VOLTAGE** — The voltage between current sense and current limit terminals necessary to cause current limiting.

**SHORT CIRCUIT CURRENT LIMIT** — The output current of the regulator with the output shorted to the negative supply.

**STANDBY CURRENT DRAIN** — The supply current drawn by the regulator with no output load and no reference voltage load.

### COMPARATORS/SENSE INTERFACE

**COMMON MODE FIRING VOLTAGE** — The CM input voltage that exceeds the dynamic range of the inputs with strobe enabled resulting in the output switching states.

**COMMON MODE RECOVERY TIME** — The time from the turn off of the CM signal to the analog input threshold of the earliest sense line pulse signal that can be processed normally. Processed normally refers to bi-polar signals greater than or less than the input threshold with a corresponding proper output.

**EQUIVALENT INPUT COMMON MODE NOISE VOLTAGE** — The change in input offset voltage due to common mode input noise.

**LOGIC INPUT HIGH VOLTAGE** — The minimum voltage allowed at a bit control gate to hold the bit off.

**LOGIC INPUT LOW VOLTAGE** — The maximum voltage allowed at a bit control gate to hold the bit on.

**OUTPUT SINK CURRENT** — The maximum negative current that can be delivered by the comparator.

**PEAK OUTPUT CURRENT** — The maximum current that may flow into the output load without causing damage to the comparator.

**PROPAGATION DELAY** — The interval between the application of an input voltage step and its arrival at either output, measured at 50% of the final value.

**RESPONSE TIME** — The interval between the application of an input step function and the time when the output crosses the logic threshold voltage. The input step drives the comparator from some initial, saturated input voltage

to an input level just barely in excess of that required to bring the output from saturation to the logic threshold voltage overdrive.

**STROBE CURRENT** — The maximum current drawn by the strobe terminals when it is at the zero logic level.

**STROBE DELAY** — The time delay measured from strobe to output threshold with a signal present exceeding the input threshold.

**STROBE RELEASE TIME** — The time required for the output to rise to the logic threshold voltage after the strobe terminal has been driven from the zero to the one logic level. Appropriate input conditions are assumed.

**STROBED OUTPUT LEVEL** — The DC output voltage, independent of input voltage, with the voltage on the strobe terminal equal to or less than a minimum specified amount.

**SWITCHING SPEED** — The time required to turn on the least significant bit.

**THRESHOLD UNCERTAINTY** — With all sense amps sharing the same input threshold less the uncertainty as a "0". This includes unit to unit, power supply and temperature variations.

**THRESHOLD VOLTAGE** — The typical referred to input voltage which determines whether an input is a "1" or a "0". A signal whose magnitude is greater than the threshold level is sensed as a logic "1" and a signal whose magnitude is less as a "0".

**ZERO SCALE OUTPUT CURRENT** — The output current for all bits turned off.

### COMMUNICATIONS CIRCUITS

**ACC DETECTOR SENSITIVITY** — The ratio of the incremental differential DC voltage change at the ACC Detector Output Terminals to the incremental change in peak-to-peak voltage at the ACC Detector Input Terminal for a specified burst input level, with the local oscillator locked.

**APC DETECTOR SENSITIVITY** — The ratio of the incremental differential DC voltage change at the APC Detector Output Terminals to the incremental change in relative phase at the APC Detector Input Terminal for a specified burst input level.

**AVERAGE TEMPERATURE COEFFICIENT OF OUTPUT VOLTAGE** — The percentage change in output voltage for a specified change in ambient temperature.

**BANDWIDTH** — The frequency at which the differential gain is 3dB below its low frequency value.

**COMMUNICATIONS CIRCUITS (Cont'd)**

**COLOR-DIFFERENCE DEMODULATION ANGLE** — A color-difference demodulation angle is defined as the instantaneous phase of the (+) Chroma input signal which produces the most positive voltage at the respective color-difference output with the phase of Reference "A" taken at 3 degrees and the phase of Reference "B" taken at 106 degrees.

(+) **CHROMA INPUT** — A composite chroma signal containing the burst at a phase of 180 degrees is demodulated to produce specified color-difference demodulation angles when applied to the (+) Chroma input.

(-) **CHROMA INPUT** — A composite chroma signal containing the burst at a phase of 0 degrees is demodulated to produce specified color-difference demodulation angles when applied to the (-) Chroma input.

**DIFFERENTIAL OUTPUT VOLTAGE SWING** — The peak differential output swing that can be obtained without clipping.

**DIFFERENTIAL VOLTAGE GAIN** — The ratio of the change in differential output voltage to the change in differential input voltage producing it.

**OSCILLATOR CONTROL SENSITIVITY** — The ratio of the incremental change in oscillator free running frequency to the incremental change in the differential DC voltage at the APC Detector Output Terminals.

**OUTPUT COMMON MODE VOLTAGE** — The average of the voltages at the two output terminals.

**OUTPUT OFFSET VOLTAGE** — The difference between the voltages at the two output terminals with the inputs grounded.

**TOTAL HARMONIC DISTORTION** — The ratio of the sum of the amplitudes of all signals harmonically related to the fundamental, and the amplitude of the fundamental signal.

# MOS

Signetics offers a broad line of MOS products including Dynamic and Static Shift Registers, Random Access Memories and Read-only Memories. The 2500 series is fabricated using Signetics' advanced P-Channel SILICON-GATE PROCESS which provides compatibility with 5 volt TTL/DTL, high speed, and low power dissipation. Also available are the 2000 and 2400 series which are P-Channel metal gate devices. MOS products are available in commercial temperature ranges. All silicon gate devices are available in silicone dual in-line packages.

## DYNAMIC SHIFT REGISTERS

**2502**  
Quad 256-Bit  
10MHz Typ. Data Rate  
 $C_{CL} = 140\text{pF max.}$   
Power Supplies +5, -5V  
40 $\mu\text{W/bit/MHz}$   
Multiplexed Data

**2503**  
Dual 512-Bit  
10MHz Typ. Data Rate  
 $C_{CL} = 140\text{pF max.}$   
Power Supplies +5, -5V  
40 $\mu\text{W/bit/MHz}$   
Multiplexed Data

**2504**  
Single 1024-Bit  
10MHz Typ. Data Rate  
 $C_{CL} = 140\text{pF max.}$   
Power Supplies +5, -5V  
40 $\mu\text{W/bit/MHz}$   
Multiplexed Data

**2505/2524**  
512-Bit  
5MHz Typ. Clock Rate  
 $C_{CL} = 80\text{pF}$   
Power Supplies +5, -5V  
100 $\mu\text{W/bit/MHz}$   
Recirculate Logic

**2506**  
Dual 100-Bit  
5MHz Typ. Clock Rate  
 $C_{CL} = 40\text{pF max.}$   
Power Supplies +5, -5V  
400 $\mu\text{W/bit/MHz}$   
Bare Drain Output

**2507**  
Dual 100-Bit  
5MHz Typ. Clock Rate  
 $C_{CL} = 40\text{pF max.}$   
Power Supplies +5, -5V  
400 $\mu\text{W/bit/MHz}$   
Resistor Pull-down (7.5K)

**2512/2525**  
1024-Bit  
5MHz Typ. Clock Rate  
 $C_{CL} = 140\text{pF}$   
Power Supplies +5, -5V  
150 $\mu\text{W/bit/MHz}$   
Recirculate Logic

**2515**  
Dual 512-Bit DSR  
5MHz Clock Rate  
 $C_{CL} = 140\text{pF}$   
Power Supplies +5, -5V  
100 $\mu\text{W/bit/MHz}$   
Recirculate +CS logic

**2517**  
Dual 100-Bit  
5MHz Typ. Clock Rate  
 $C_{CL} = 40\text{pF max.}$   
Power Supplies +5, -5V  
400 $\mu\text{W/bit/MHz}$   
Resistor Pull-down (20K)

## STATIC SHIFT REGISTERS

**2509**  
Dual 50 Bit  
3MHz Typ. Clock Rate  
Data & Clock TTL Compatible  
Tri-State Outputs  
Recirculate Logic  
Power Supplies +5, -5, -12V

**2510**  
Dual 100-Bit  
3MHz Typ. Clock Rate  
Data & Clock TTL Compatible  
Tri-State Outputs  
Recirculate Logic  
Power Supplies +5, -5, -12V

**2511**  
Dual 200-Bit  
3MHz Typ. Clock Rate  
Data & Clock TTL Compatible  
Tri-State Outputs  
Recirculate Logic  
Power Supplies +5, -5, -12V

**2518**  
Hex 32-Bit  
2MHz Typ. Clock Rate  
Data & Clock TTL Compatible  
Recirculate Logic  
Power Supplies +5, -12V

**2519**  
Hex 40-Bit  
2MHz Typ. Clock Rate  
Data & Clock TTL Compatible  
Recirculate Logic  
Power Supplies +5, -12V

**2521**  
Dual 128-Bit  
3MHz Typ. Clock Rate  
Data & Clock TTL Compatible  
Recirculate Logic  
Power Supplies +5, -12V

**2522**  
Dual 132-Bit  
3MHz Typ. Clock Rate  
Data & Clock TTL Compatible  
Recirculate Logic  
Power Supplies +5, -12V

**2000 SERIES**  
Static Shift Registers  
 $C_L = 5\text{pF}$   
-14, -28V Power Supplies

**2001**  
Dual 16-Bit SSR  
0-1MHz

**2002**  
Dual 25-Bit SSR  
0-1MHz

**2003**  
Dual 32-Bit SSR  
0-1MHz

**2004**  
Dual 50-Bit SSR  
0-1MHz

**2005**  
Dual 100-Bit SSR  
0-1MHz

**2010**  
Dual 100-Bit SSR  
0-3MHz

## RANDOM ACCESS MEMORIES

**2501**  
256x1 Static RAM  
Decoded  
Access Time 1 $\mu\text{s Max.}$   
1mW/bit Typ.  
Power Supplies +5, -7, -10V or +5, -9V

**2508**  
1024 x 1 Dynamic RAM  
Decoded  
Access Time 330ns  
Cycle Time 500ns  
3 Chip Selects  
2.7mA  
4 Clocks  
+5, -12V  
TTL Compatible Inputs  
100mW

## READ-ONLY MEMORIES

**2513**  
64x8x5 Static Character Generator  
Row Output  
600ns Max. Access Time  
ASCII Font Std.  
Power Supplies +5, -5, -12V  
350mW

**2514**  
512x5 Read-Only Memory  
600ns Max. Access Time  
Power Supplies +5, -5, -12V  
350mW

**2516**  
64x6x8 Static Character Generator  
Column Output  
750ns Max. Access Time  
Power Supplies +5, -5, -12V  
415mW

**2400 SERIES**  
Static Read-Only Memories  
550ns Access Time  
250mW  
+12, -12V Power Supplies  
Bare Drain or MOS Pull-Down Resistor

**2410**  
256x4  
16-pin DIP

**2420**  
256x4, 128x8  
Single or 3-line Chip Enable  
24-pin DIP

**2430**  
256 x 8, 512 x 4  
Single or 3-line Chip Enable  
24-pin DIP

**SECTION 10**  
**sales offices**



- **New England Regional Sales Office:** Miller Building Suite 11, 594 Marrett Road, Lexington, Massachusetts 02173  
Phone: (617) 861-0840 TWX: (710) 326-6711
- **Atlantic States Regional Sales Office:** 2460 Lemoine Ave., Fort Lee, New Jersey 07024  
Phone: (201) 947-9870 TWX: (710) 991-9794  
**Florida:** 3267 San Mateo, Clearwater, 33515  
Phone: (813) 726-3469 TWX: (810) 866-0437  
**Florida:** 4347 Northwest 2nd Court  
Boca Raton, Florida 33432 Phone: (305) 391-8318 TWX: (510) 953-7538  
**Maryland:** Silver Springs  
Phone: (301) 946-6030  
**Pennsylvania and Southern New Jersey:** P.O. Box 431, Oakwood Drive, Medford, New Jersey 08055  
Phone: (609) 665-5071  
**Virginia:** 12001 Whip Road, Reston, 22070  
Phone: (301) 946-6030
- **Central Regional Sales Office:** 5105 Tollview Drive, Suite 209, Rolling Meadows, Illinois 60008  
Phone: (312) 259-8300 TWX: (910) 687-0765  
**Minnesota:** 7710 Computer Ave., Suite 132, Minneapolis 55435  
Phone: (612) 922-2801 TWX: (910) 576-2740  
**Ohio:** 3300 So. Dixie Drive, Suite 220, Dayton 45439  
Phone: (513) 294-8722
- **Northwest Regional Sales Office:** 811 E. Arques, Sunnyvale, Ca 94086  
Phone: (408) 739-7700 TWX: (910) 339-9220  
(910) 339-9283
- **Southwest Regional Sales Office:** 2061 Business Center Dr., Suite 214, Irvine, Ca. 92664  
Phone: (714) 833-8980, (213) 437-6718, TWX: (910) 595-1506  
**California:** P.O. Box 788, Del Mar, 92014  
Phone: (714) 453-7570

## REPRESENTATIVES

### ALABAMA

**Huntsville 35801:** Compar Corp., 904 Bob Wallace Ave., Suite A  
Phone: (205) 539-8476

### ARIZONA

**Scottsdale 85252:** Compar Corp., Box 1607  
Phone: (602) 947-4336 TWX: (910) 950-1293

### CALIFORNIA

**San Diego 92123:** Celtec Company, Inc., 8799 Balboa Avenue  
Phone: (714) 279-7961 TWX: (910) 335-1512

### CANADA

**Toronto 17, Ontario:** Corning Glass Works of Canada, Ltd.,  
135 Vanderhoff Ave.

Phone: (416) 421-1500 TWX: (610) 491-2155

**Montreal 265, Quebec:** Corning Glass Works of Canada,  
7065 Chester Ave.

### COLORADO

**Denver 80237:** Parker Webster Company, 8213 E. Kenyon Dr.  
Phone: (303) 770-1972

### CONNECTICUT

**Hamden 06518:** Compar Corp., P.O. Box 5204  
Phone: (203) 288-9276 TWX: (710) 465-1540

### FLORIDA

**Altamonte Springs 32701:** WMM Associates Inc., 515 Tivoli Ct.  
Phone: (305) 831-4645

**Clearwater 33516:** WMM Associates Inc., 1260A S. Highland Ave.  
Phone: (813) 446-0075

**Pompano Beach 33060:** WMM Associates Inc., 721 South East 6th Terrace  
Phone: (305) 943-3091

### INDIANA

**Indianapolis 46250:** R. H. Newsom Associates, 6320 Woburn Dr.  
Phone: (317) 849-4442

### MARYLAND

**Silver Springs 20904:** Mechtronics Sales Inc., 11700 Old Columbia  
Pike, Suite L-6 Phone: (301) 622-2420

### MASSACHUSETTS

**Newton Highlands 02161:** Compar Corp., 88 Needham Street  
Phone: (617) 969-7140 TWX: (710) 335-1686

### MICHIGAN

**Grosse Pointe Park 48230:** Greiner Associates Inc., 15324 E. Jefferson  
Phone: (313) 499-0188, (313) 499-0189 TWX: (801) 221-5157

### MINNESOTA

**Minneapolis 55416:** Compar Corp., P.O. Box 16095  
Phone: (612) 922-7011

### MISSOURI

**St. Louis 63141:** Compar Corp., 11734 Lackland Industrial Drive  
Phone: (314) 567-3399 TWX: (910) 764-0839

### SOUTHERN NEW JERSEY AND PENNSYLVANIA

**Haddonfield, N.J. 08033:** Compar Corp., 15 Potter Street  
Phone: (609) 429-1526 TWX: (710) 896-0679

### NEW MEXICO

**Albuquerque 87104:** Compar Corp., 113 Romero St. N.W.  
Phone: (505) 242-3633 TWX: (910) 989-1659

### UPSTATE NEW YORK

**Dewitt 13214:** TriTech Electronics, Inc.,  
P.O. Box C Phone: (315) 446-2881

### NORTH CAROLINA

**Winston-Salem 27101:** Compar Corp., 1106 Burke Street  
Phone: (919) 723-1002 TWX: (510) 931-3101

### OHIO

**Dayton 45405:** Compar Corp., P.O. Box 57, Forest Park Branch  
Phone: (415) 435-1301

**Fairview Park 44126:** Compar Corp., P.O. Box 4791  
Phone: (216) 333-4120 TWX: (810) 421-8396

### TEXAS

**Richardson 75080:** Semiconductor Sales Associates,  
312 North Central Expressway, Suite 213  
Phone: (214) 231-6181

### WASHINGTON

**Bellevue 98009:** Western Technical Sales, P.O. Box 902  
Phone: (206) 454-3906 TWX: (910) 443-2309

## DISTRIBUTORS

### ARIZONA

**Phoenix 85009:** Hamilton/Avnet Electronics, 1739 N. 28th Ave.  
Phone: (602) 269-1391, TELEX: 667-450

### CALIFORNIA

**Burbank 91504:** Compar Corp., 2908 Naomi Avenue  
Phone: (213) 843-1772 TWX: (910) 498-2203

**Burlingame 94010:** Compar Corp., 820 Airport Blvd.  
Phone: (415) 347-5411 TWX: (910) 374-2366

**Culver City 90230:** Hamilton Electro Sales, 10912 W. Washington  
Phone: (213) 559-3311 TELEX: 677-100, 674-381, 674-354

**El Monte 91731:** G.S. Marshall, 9674 Telstar Avenue  
Phone: (213) 686-1500 TWX: (910) 587-1565

**Los Angeles 90022:** KT/Wesco Electronics, 5650 Jillson Street  
Phone: (213) 685-9525 TWX: (910) 580-1980

**Mountain View 94041:** Hamilton/Avnet Electronics, 340 East Middlefield Rd  
Phone: (415) 961-7000 TELEX: 348-201

**Palo Alto 94303:** Wesco Electronics, 3973 East Bayshore Road  
Phone: (415) 968-3475 TWX: (910) 379-6488

**San Diego 92111:** G.S. Marshall, 7990 Engineer Road, Suite 1  
Phone: (714) 278-6350 TWX: (910) 587-1565

**San Diego 92123:** Kierulff Electronics, 8797 Balboa Avenue  
Phone: (714) 278-2112 TWX: (910) 335-1182

### CANADA

**Downsview, Ontario:** Cesco Electronics, Ltd., 24 Martin Ross Avenue  
Phone: (416) 638-5250

**Montreal, Quebec:** Cesco Electronics, Ltd., 4050 Jean Talon West  
Phone: (514) 735-5511 TWX: (610) 421-3445

**Ottawa, Ontario:** Cesco Electronics, Ltd., 1300 Carling Avenue  
Phone: (613) 729-5118

**Quebec:** Cesco Electronics, Ltd., 128 St. Vallier Street  
Phone: (418) 524-3518

### COLORADO

**Denver 80216:** Hamilton/Avnet Electronics, 1400 W. 46th Avenue  
Phone: (303) 433-8551 TELEX: 45872

### FLORIDA

**Woodward 33021:** Hamilton/Avnet Electronics, 4020 No. 29th Avenue  
Phone: (305) 925-5401 TELEX: 51-4328

**Orlando 32805:** Hammond Electronics, 911 West Central Blvd.  
Phone: (305) 241-6601 TWX: (810) 850-4121

### ILLINOIS

**Elmhurst 60126:** Semiconductor Specialists, Inc., 195 Spangler Avenue  
Elmhurst Industrial Park

Phone: (312) 279-1000 TWX: (910) 254-0169

**Schiller Park 60176:** Hamilton/Avnet Electronics, 3901 Pace Court  
Phone: (312) 678-6310 TELEX: 728-330

### MARYLAND

**Hanover 21076:** Hamilton/Avnet Electronics, 7255 Standard Drive  
Phone: (301) 796-5000 TELEX: 879-68

**Rockville 20850:** Pioneer Washington Electronics, Inc., 1037 Taft Street  
Phone: (301) 424-3300

## SIGNETICS ■ SALES OFFICE

### MASSACHUSETTS

**Burlington 01803: Hamilton/Avnet Electronics**

207 Cambridge Street

Phone: (617) 272-3060 TELEX: 9494-61

**Needham Heights 02194: Kieruff/Schley**, 14 Charles Street

Phone: (617) 449-3600 TWX: (710) 325-1179

### MICHIGAN

**Livonia 48150: Hamilton/Avnet Electronics**, 13150 Wayne Rd.

Phone: (313) 522-4700

**Detroit 48240: Semiconductor Specialists, Inc.**, 25127 W Six Mile Road

Phone: (313) 255-0300 TWX: (910) 254-0169

### MINNESOTA

**Minneapolis 55420: Semiconductor Specialists, Inc.**, 8030 Cedar Ave., S.

Phone: (612) 854-8841

### MISSOURI

**Hazelwood 63042: Hamilton/Avnet Electronics**, 400 Brookes Lane

Phone: (314) 731-1144 TELEX: 442348

### NORTHERN NEW JERSEY

**Cedar Grove 07009: Hamilton/Avnet Electronics**, 220 Little Falls Road

Phone: (201) 239-0800 TELEX: 138313

### SOUTHERN NEW JERSEY AND PENNSYLVANIA

**Cherry Hill, N.J. 08034: Hamilton/Avnet Electronics**, 1608-10 W Marlton Pike

Phone: (609) 662-9337 TELEX: 834737

**Cherry Hill, N.J. 08034: Milgray-Delaware Valley**, 1165 Markress Road

Phone: N.J. (609) 424-1300 Phila. (215) 228-2000 TWX: (710) 896-0405

### NEW YORK

**Buffalo 14202: Summit Distributors, Inc.**, 916 Main Street

Phone: (716) 884-3450 TWX: (710) 522-1692

**Hauppauge, L.I. 11787: Semiconductor Concepts, Inc.**, Engineer Road

Phone: (516) 273-1234 TWX: (510) 227-6232

**Woodbury, L. I. 11797: Harvey Radio**, 60 Crossways Park West

Phone: (516) 921-8700 TWX: (510) 221-2184

**New York 10011: Terminal-Hudson Electronics**, 23C West 17th Street

Phone: (212) 243-5200 TWX: (710) 581-3962

### OHIO

**Cleveland 44105: Pioneer Standard Electronics, P.O. Box 05100**

Phone: (216) 587-3600, TWX: (810) 421-8238

**Kettering 45429: Arrow Electronics**, 3100 Plainfield Road

Phone: (513) 253-9176 TWX: (810) 459-1611

### TEXAS

**Dallas 75207: Hamilton/Avnet Electronics**, 2403 Farrington Ave

Phone: (214) 638-2850 TELEX: 732359

**Dallas 75220: Solid State Electronics Company, P. O. Box 20299**

Phone: (214) 352-2601

**Houston 77019: Hamilton/Avnet Electronics**, 1216 West Clay Street

Phone: (713) 526-4661 TELEX: 762589

**Houston 77036: Universal Electronics**, 5723 Savoy Street

Phone: (713) 781-0421

### WASHINGTON

**Seattle 98121: Hamilton/Avnet Electronics**, 2320 Sixth Avenue

Phone: (206) 624-5930 TELEX: 32249

## INTERNATIONAL SALES

### EUROPEAN HEADQUARTERS:

**Signetics International Corp.**, Yeoman House, 63 Croydon Rd.,

Penge, London, S.E. 20, England

Phone: (01) 6592111 TELEX: 946619

### FRANCE:

**Signetics S.A.R.L.**, 90 Rue Baudin F. 92 Levallois-Perret, France

Phone: 739-85-80/739-96-40 TELEX 62014

### WEST GERMANY:

**Signetics GmbH**, Ernstthalenstrasse 17, D 7 Stuttgart 80, West Germany

Phone: (0711) 73-50-61 TELEX: 7255798

### STOCKING DISTRIBUTORS

#### AUSTRALIA

**Pye Industries Ltd.**, Technico Electronics Division, 53 Carrington Rd.,

Marrickville, Sydney, N.S.W.

Phone 55-0411 TELEX: 790-21490

**Pye Industries Ltd.**, Technico Electronics Division, 2-18 Normanby Rd.,

South Melbourne, Vic

Phone: 69-60-61 TELEX 31240

#### WEST GERMANY

**EBV Elektronik GmbH**, Augustenstrasse 79, D-8 Munchen 2

Phone: (0811) 52-43-40/48 TELEX: 524535

**EBV Elektronik GmbH**, Myliusstrasse 54, D-6 Frankfurt/Main 1

Phone: (0611) 72-04-16/18 TELEX: 413590

**EBV Elektronik GmbH**, Scheurenstrasse 1, D-4 Dusseldorf

Phone: (0211) 8-48-46/47 TELEX: 8587267

**"Mutron" Muller & Co. KG**, Postfach 164, Bornstrasse 65, D-28 Bremen 1

Phone: (0421) 31-04-85 TELEX: 245-325

**Dima-Elektronik, Karl Manger KG**, Postfach 80 0744,

Robert-Leichtstrasse 43, D-7 Stuttgart-Vaihingen 80

Phone: (0711) 73-40-50/9 TELEX: 255-642

**Distron GmbH**, D-1 Berlin 31, Wilhelmsaue 39-41

Phone: 0311/870144 TELEX: 18-27-58

**Signetics GmbH**, Eulenkrugstr. 81 E, D-2 Hamburg 67

Phone: (411) 60-35-242

#### AUSTRIA

**Ing. Ernst Steiner**, Beckgasse 30, A-1130 Wien

Phone: (222) 82-10-605

#### SWITZERLAND

**Dewald AG**, Seestrasse 561, CH 8038, Zurich

Phone: (051) 45-13-00 TELEX: 52012

#### FRANCE

**S.A. Gallec Electronique**, 78, Avenue des Champs-Elysées, Paris 8e

Phone: 359-58-38/255-67-10/255-67-11

**R.T.F.**, 73, Av. de Neuilly, 92 - Neuilly sur Seine, Paris

Phone: 722.70.40 TELEX: 65.933

**Eiic 38, le Bureau Barisien S.A.R.L.**, 8-10 Avenue du Grand Sablon,

38-La Tronche

Phone (76) 87-67-71 TELEX: 32-739

#### ITALY

**Metroletronica S.A.S.**, Viale Cirene 18, I-20135 Milano

Phone: 546-26-41 TELEX: 33-168 Metronica

#### UNITED KINGDOM

**Quarndon Electronics Ltd.**, Slack Lane, Derby, Derbyshire

Phone: (0332) 3 26 51 TELEX: 37163

**S.D.S. (Portsmouth) Ltd.**, Halsea Industrial Estate, Portsmouth, Hampshire

Phone: 6 53 11 TELEX: 86114

**Semicomps Ltd.**, 5 Northfield Industrial Estate, Beresford Ave., Wembley,

Middlesex Phone: (01) 903-3161 TELEX: 935243

**A.M. Lock & Co. Ltd.**, 79 Union St., Oldham, Lancs, England

Phone: 061-624-6832

#### SCOTLAND

**Semicomps Northern Ltd.**, 44, The Square, Kelso, Roxburghshire

Phone: 2366 TELEX: 72692

#### SWEDEN, NORWAY, FINLAND

**A.B. Kuno Källman**, Järntorget 7, S-413 04 Gothenburg, Sweden

Phone: 17-01-20 TELEX: 21072

#### DENMARK

**E. Friis-Mikkelsen A/S**, Krogshøjvej 51, DK-2880 Bagsvaerd

Phone: (01) 986333 TELEX: 2350

#### THE NETHERLANDS

**Mulder-Hardenberg**, P.O. Box 5059, Westerhoutpark 1-A, Haarlem

Phone: (023) 3191 84 TELEX: 41431

#### JAPAN

**Asahi Glass Co., Ltd.**, 1-2, Marunouchi, 2 Chome Chiyoda-ku, Tokyo

Phone: 211-0411 TELEX: 4616

#### SOUTH AFRICA

**Indentronics Proprietary, Ltd.**, Sheerline House, 24 Webber Street,

Selby, Johannesburg

Phone: 834-4971/2/3 TELEX: 43-7660JH

## REPRESENTATIVES

### SWEDEN, NORWAY, FINLAND

**A.B. Kuno Källman**, Järntorget 7, S-413 04 Gothenburg, Sweden

Phone: 17-01-20 TELEX: 21072

### AUSTRALIA

**Corning Australia, Technical Products Division**, Room 13, Barden House,

Fetherston Street, Bankstown, N.S.W. 2200

Phone: 602-9011 TELEX: 21539

### ISRAEL

**Rapac Electronics Ltd.**, P.O. Box 18053, 15 Karl Herbst St.,

Tel-Baruch, Tel-Aviv Phone: 77 71 15,6,7 TELEX: TV 528

### JAPAN

**Asahi Glass Co., Ltd.**, 1-2, Marunouchi, 2 Chome Chiyoda-ku, Tokyo

Phone: 211-0411 TELEX: 4616

### SWITZERLAND

**Dewald AG**, Seestrasse 561, CH 8038, Zurich

Phone: (051) 45-13-00 TELEX: 52012

### INDIA

**Semiconductors Limited**, Radia House, 6, Rampart Row,

Fort, Bombay - 1

Phone: 293667 TELEX: Transducer, Bombay

### SOUTH AFRICA

**Indentronics Proprietary, Ltd.**, Sheerline House, 24 Webber Street,

Selby, Johannesburg

Phone: 834-4971/2/3 TELEX: 43-7660JH





---

