

DIMENSION

DIP-8 DIMENSION (FIG. NO. DIM-DIP8-0103-B)

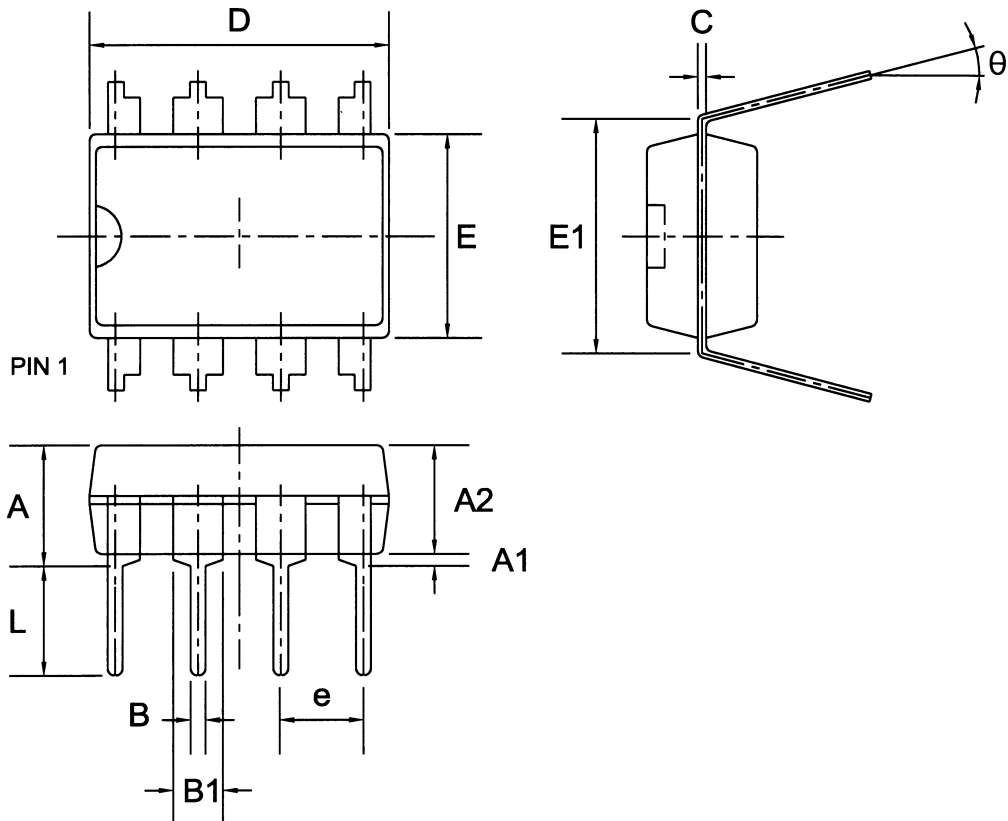

Symbol	Dimensions In Millimeters			Dimensions In Inches		
	Min	Nom	Max	Min	Nom	Max
A	—	—	4.31	—	—	0.170
A1	0.38	—	—	0.015	—	—
A2	3.15	3.40	3.65	0.124	0.134	0.144
B	0.38	0.46	0.51	0.015	0.018	0.020
B1	1.27	1.52	1.77	0.050	0.060	0.070
C	0.20	0.25	0.30	0.008	0.010	0.012
D	8.95	9.20	9.45	0.352	0.362	0.372
E	6.15	6.40	6.65	0.242	0.252	0.262
E1	—	7.62	—	—	0.300	—
e	—	2.54	—	—	0.100	—
L	3.00	3.30	3.65	0.118	0.130	0.142
theta	0°	—	15°	0°	—	15°

UTC UNISONIC TECHNOLOGIES CO., LTD.

DIMENSION

DIP-14 DIMENSION (FIG. NO. DIM-DIP14-0103-B)

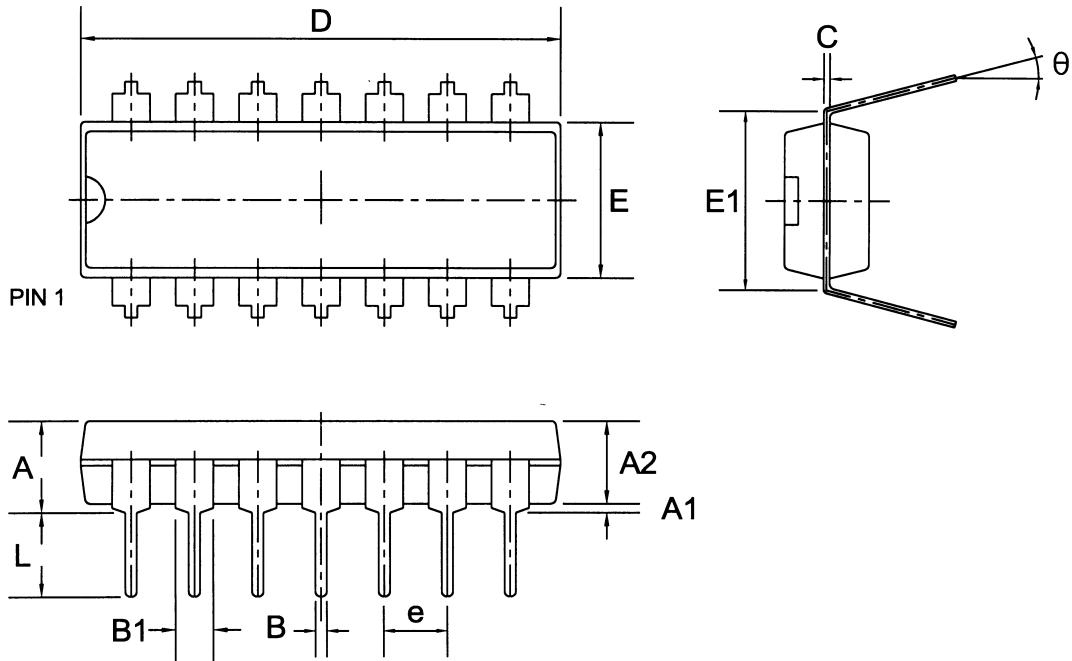

Symbol	Dimensions In Millimeters			Dimensions In Inches		
	Min	Nom	Max	Min	Nom	Max
A	—	—	4.31	—	—	0.170
A1	0.38	—	—	0.015	—	—
A2	3.15	3.40	3.65	0.124	0.134	0.144
B	—	0.46	—	—	0.018	—
B1	—	1.52	—	—	0.060	—
C	—	0.25	—	—	0.010	—
D	19.00	19.30	19.60	0.748	0.760	0.772
E	6.20	6.40	6.60	0.244	0.252	0.260
E1	—	7.62	—	—	0.300	—
e	—	2.54	—	—	0.100	—
L	3.00	3.30	3.60	0.118	0.130	0.142
theta	0°	—	15°	0°	—	15°

UTC UNISONIC TECHNOLOGIES CO., LTD.

DIMENSION

DIP-28 DIMENSION (FIG. NO. DIM-DIP28-0103-B)

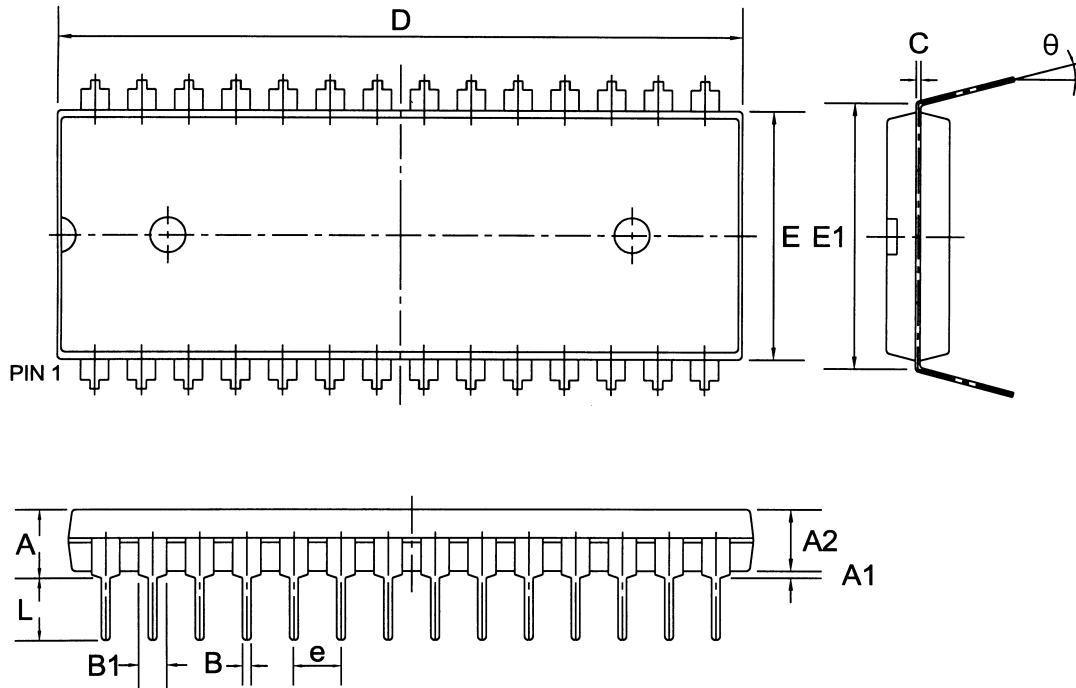

Symbol	Dimensions In Millimeters			Dimensions In Inches		
	Min	Nom	Max	Min	Nom	Max
A	—	—	5.34	—	—	0.210
A1	0.38	—	—	0.015	—	—
A2	3.65	3.85	4.05	0.144	0.152	0.159
B	—	0.46	—	—	0.018	—
B1	—	1.52	—	—	0.060	—
C	—	0.25	—	—	0.010	—
D	36.80	37.10	37.40	1.449	1.461	1.472
E	13.40	13.70	14.00	0.528	0.539	0.551
E1	—	15.24	—	—	0.600	—
e	—	2.54	—	—	0.100	—
L	3.00	3.30	3.60	0.118	0.130	0.142
θ	0°	—	15°	0°	—	15°

UTC UNISONIC TECHNOLOGIES CO., LTD.

DIMENSION

DIP-12H DIMENSION (FIG. NO. DIM-DIP12H-0103-B)

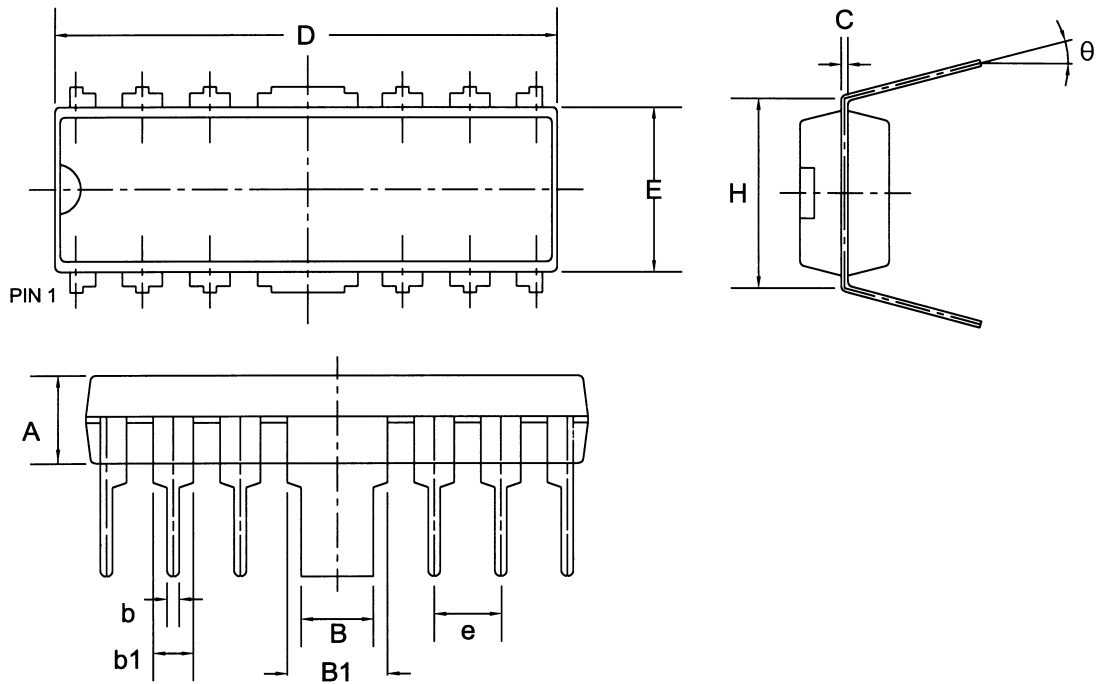

Symbol	Dimensions In Millimeters			Dimensions In Inches		
	Min	Nom	Max	Min	Nom	Max
A	3.15	3.40	3.65	0.124	0.134	0.144
B	—	3.00	—	—	0.118	—
B1	—	4.06	—	—	0.160	—
b	—	0.46	—	—	0.018	—
b1	—	1.52	—	—	0.060	—
C	—	0.25	—	—	0.010	—
D	18.90	19.00	19.10	0.744	0.748	0.752
E	6.20	6.30	6.40	0.244	0.248	0.252
H	7.37	7.62	7.87	0.290	0.300	0.310
e	—	2.54	—	—	0.100	—
θ	0°	—	15°	0°	—	15°

UTC UNISONIC TECHNOLOGIES CO., LTD.

DIMENSION

SDIP-24 DIMENSION (FIG. NO. DIM-SDIP24-0103-A)

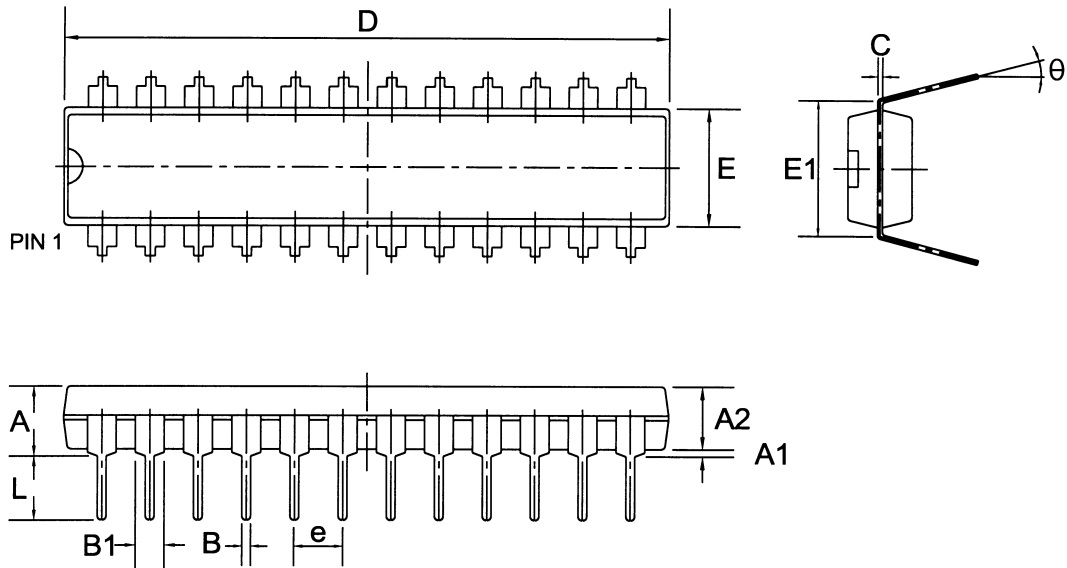

Symbol	Dimensions In Millimeters			Dimensions In Inches		
	Min	Nom	Max	Min	Nom	Max
A	—	—	4.31	—	—	0.170
A1	0.38	—	—	0.015	—	—
A2	3.15	3.40	3.65	0.124	0.134	0.144
B	—	0.43	—	—	0.017	—
B1	—	1.05	—	—	0.041	—
C	—	0.25	—	—	0.010	—
D	22.82	23.12	23.32	0.898	0.910	0.918
E	6.15	6.40	6.65	0.242	0.252	0.262
E1	—	7.62	—	—	0.300	—
e	—	1.78	—	—	0.100	—
L	3.00	3.30	3.60	0.118	0.130	0.142
θ	0°	—	15°	0°	—	15°

UTC UNISONIC TECHNOLOGIES CO., LTD.

DIMENSION

FSIP-12H DIMENSION (FIG. NO. DIM-FSIP12-0103-B)

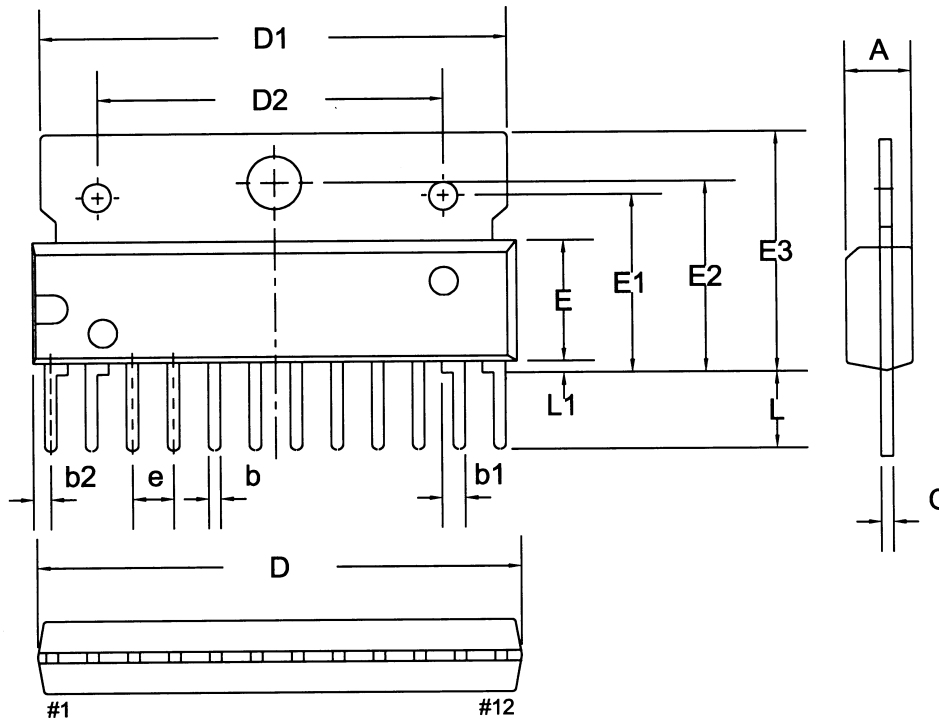

Symbol	Dimensions In Millimeters			Dimensions In Inches		
	Min	Nom	Max	Min	Nom	Max
A	3.80	4.00	4.20	0.150	0.157	0.165
b	0.40	0.50	0.60	0.016	0.020	0.024
b1	0.85	0.95	1.05	0.033	0.037	0.041
b2	—	0.83	—	—	0.033	—
C	0.35	0.40	0.50	0.014	0.016	0.020
D	29.40	29.60	29.80	1.157	1.165	1.173
D1	27.80	28.00	28.20	1.094	1.102	1.110
D2	21.80	22.00	22.20	0.858	0.866	0.874
E	7.80	8.00	8.20	0.307	0.315	0.323
E1	11.30	11.50	11.70	0.445	0.453	0.461
E2	12.30	12.50	12.70	0.484	0.492	0.500
E3	—	—	15.20	—	—	0.598
e	—	2.54	—	—	0.100	—
L	5.20	5.50	5.80	0.205	0.217	0.228
L1	0.30	0.50	0.70	0.012	0.020	0.028

UTC UNISONIC TECHNOLOGIES CO., LTD.

DIMENSION

SOP-8 DIMENSION (FIG. NO. DIM-SOP8-0103-B)

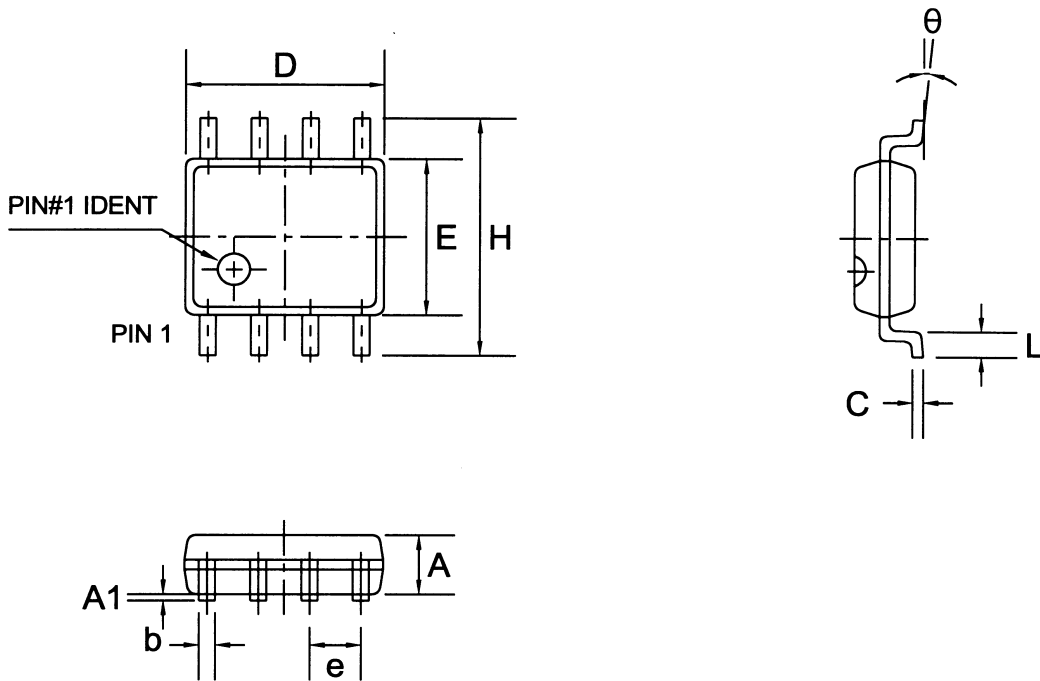

Symbol	Dimensions In Millimeters			Dimensions In Inches		
	Min	Nom	Max	Min	Nom	Max
A	1.30	1.50	1.70	0.051	0.059	0.067
A1	0.06	0.16	0.26	0.002	0.006	0.010
b	0.30	0.40	0.55	0.012	0.016	0.022
C	0.15	0.25	0.35	0.006	0.010	0.014
D	4.72	4.92	5.12	0.186	0.194	0.202
E	3.75	3.95	4.15	0.148	0.156	0.163
e	—	1.27	—	—	0.050	—
H	5.70	6.00	6.30	0.224	0.236	0.248
L	0.45	0.65	0.85	0.018	0.026	0.033
θ	0°	—	8°	0°	—	8°

UTC UNISONIC TECHNOLOGIES CO., LTD.

DIMENSION

SOP-14 DIMENSION (FIG. NO. DIM-SOP14-0103-B)

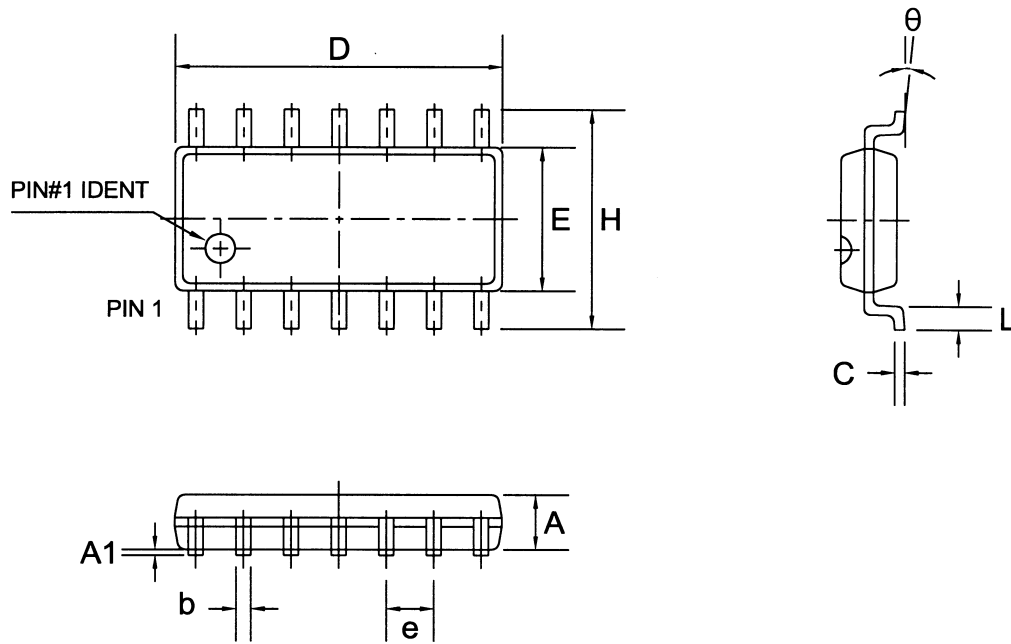

Symbol	Dimensions In Millimeters			Dimensions In Inches		
	Min	Nom	Max	Min	Nom	Max
A	1.30	1.50	1.70	0.051	0.059	0.067
A1	0.08	0.16	0.24	0.003	0.006	0.009
b	—	0.40	—	—	0.016	—
C	—	0.25	—	—	0.010	—
D	8.25	8.55	8.85	0.325	0.337	0.348
E	3.75	3.95	4.15	0.148	0.156	0.163
e	—	1.27	—	—	0.050	—
H	5.70	6.00	6.30	0.224	0.236	0.248
L	0.45	0.65	0.85	0.018	0.026	0.033
θ	0°	—	8°	0°	—	8°

UTC UNISONIC TECHNOLOGIES CO., LTD.

DIMENSION

SOP-16 DIMENSION (FIG. NO. DIM-SOP16-0103-B)

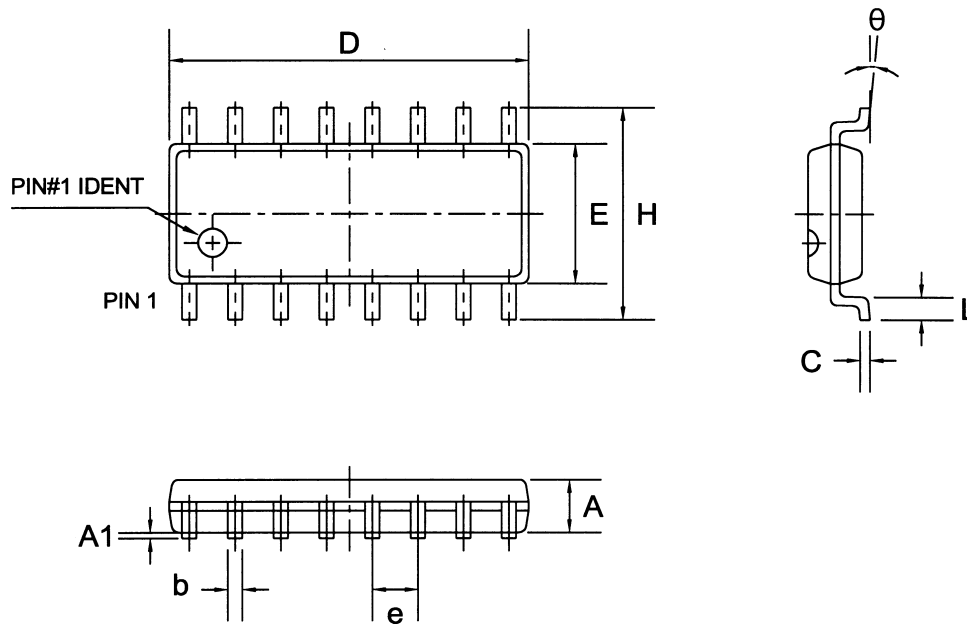

Symbol	Dimensions In Millimeters			Dimensions In Inches		
	Min	Nom	Max	Min	Nom	Max
A	1.30	1.50	1.70	0.051	0.059	0.067
A1	0.06	0.16	0.26	0.002	0.006	0.010
b	0.30	0.40	0.55	0.012	0.016	0.022
C	0.15	0.25	0.35	0.006	0.010	0.014
D	9.70	10.00	10.30	0.382	0.394	0.406
E	3.75	3.95	4.15	0.148	0.156	0.163
e	—	1.27	—	—	0.050	—
H	5.70	6.00	6.30	0.224	0.236	0.248
L	0.45	0.65	0.85	0.018	0.026	0.033
theta	0°	—	8°	0°	—	8°

DIMENSION

SOP-20 DIMENSION (FIG. NO. DIM-SOP20-0103-A)

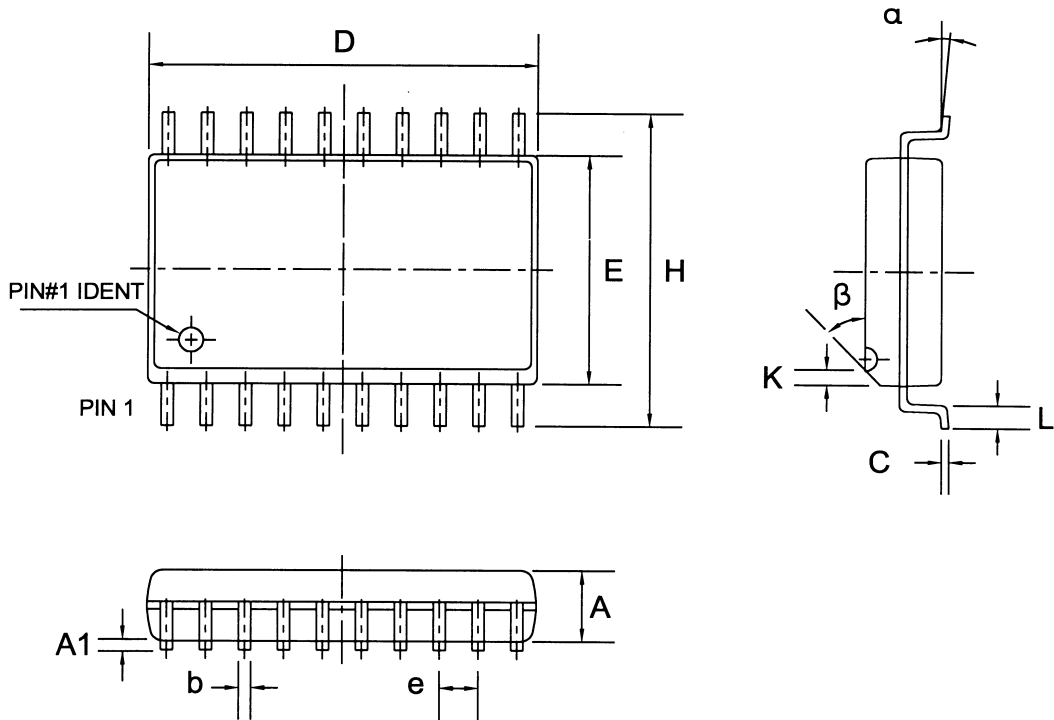

Symbol	Dimensions In Millimeters			Dimensions In Inches		
	Min	Nom	Max	Min	Nom	Max
A	2.15	2.35	2.55	0.085	0.093	0.100
A1	0.05	0.15	0.25	0.002	0.006	0.010
b	—	0.40	—	—	0.016	—
C	—	0.25	—	—	0.010	—
D	12.40	12.70	13.00	0.488	0.500	0.512
E	7.40	7.65	7.90	0.291	0.301	0.311
e	—	1.27	—	—	0.050	—
H	10.15	10.45	10.75	0.400	0.411	0.423
K	—	0.50	—	—	0.020	—
L	0.60	0.80	1.00	0.024	0.031	0.039
α	0°	—	8°	0°	—	8°
β	—	45°	—	—	45°	—

UTC UNISONIC TECHNOLOGIES CO., LTD.

DIMENSION

SOP-24 DIMENSION (FIG. NO. DIM-SOP24-0103-A)

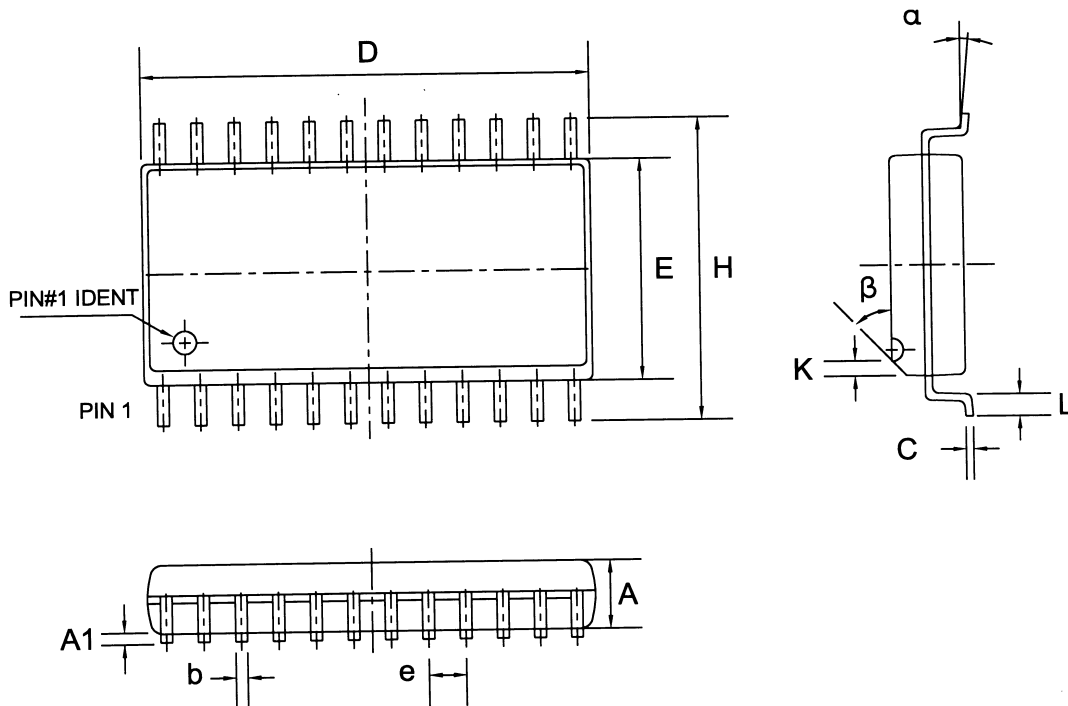

Symbol	Dimensions In Millimeters			Dimensions In Inches		
	Min	Nom	Max	Min	Nom	Max
A	2.35	2.50	2.65	0.093	0.098	0.104
A1	0.10	0.20	0.30	0.004	0.008	0.012
b	—	0.40	—	—	0.016	—
C	—	0.25	—	—	0.010	—
D	15.10	15.40	15.70	0.594	0.606	0.618
E	7.35	7.50	7.65	0.289	0.295	0.301
e	—	1.27	—	—	0.050	—
H	10.15	10.45	10.75	0.400	0.411	0.423
K	—	0.50	—	—	0.020	—
L	0.60	0.80	1.00	0.024	0.031	0.039
α	0°	—	8°	0°	—	8°
β	—	45°	—	—	45°	—

UTC UNISONIC TECHNOLOGIES CO., LTD.

DIMENSION

SOP-28 DIMENSION (FIG. NO. DIM-SOP28-0103-B)

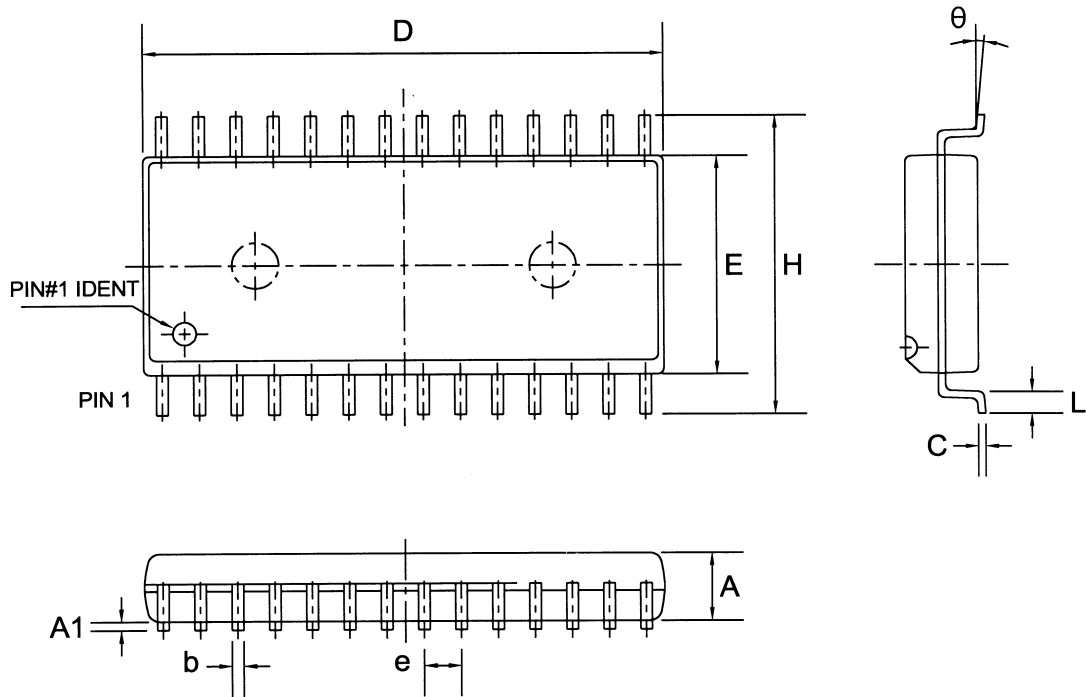

Symbol	Dimensions In Millimeters			Dimensions In Inches		
	Min	Nom	Max	Min	Nom	Max
A	2.15	2.35	2.55	0.085	0.093	0.100
A1	0.05	0.15	0.25	0.002	0.006	0.010
b	—	0.40	—	—	0.016	—
C	—	0.25	—	—	0.010	—
D	17.40	17.70	18.00	0.685	0.697	0.709
E	7.40	7.65	7.90	0.291	0.301	0.311
e	—	1.27	—	—	0.050	—
H	10.15	10.45	10.75	0.400	0.411	0.423
L	0.60	0.80	1.00	0.024	0.031	0.039
θ	0°	—	8°	0°	—	8°

UTC UNISONIC TECHNOLOGIES CO., LTD.

DIMENSION

TO-92 DIMENSION (FIG. NO. DIM-TO92-0104-B)

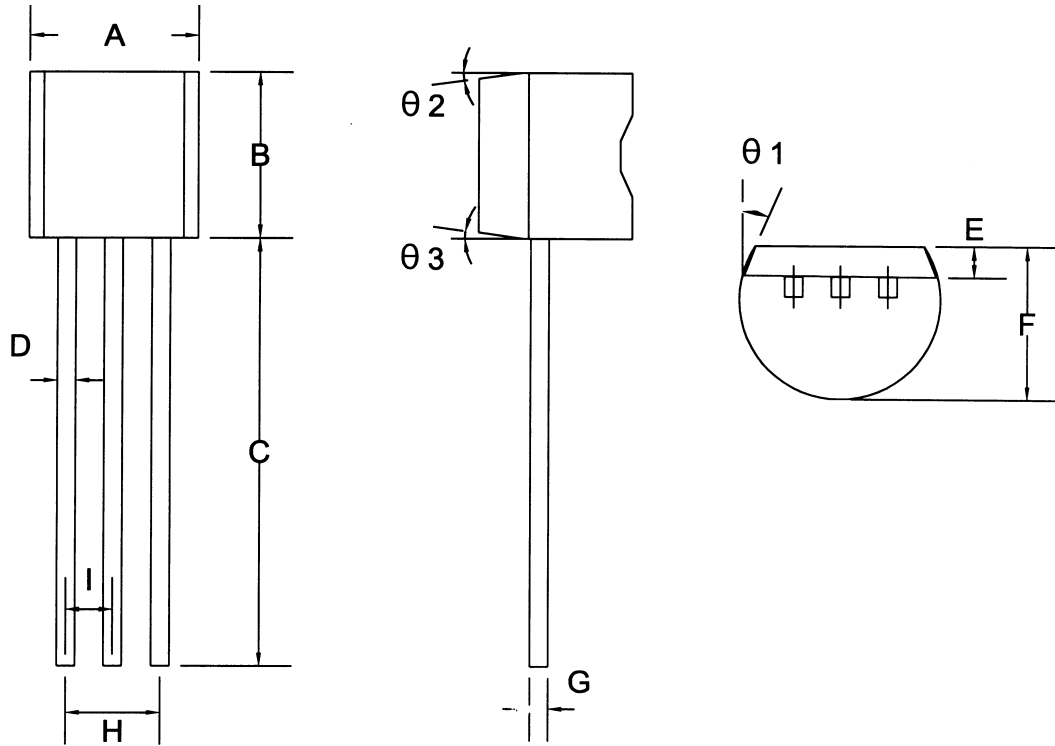

Symbol	Dimensions In Millimeters			Dimensions In Inches		
	Min	Nom	Max	Min	Nom	Max
A	4.33	4.58	4.83	0.170	0.180	0.190
B	4.33	4.58	4.83	0.170	0.180	0.190
C	14.07	14.47	14.87	0.554	0.570	0.585
D	0.34	0.44	0.54	0.013	0.017	0.021
E	0.92	1.02	1.12	0.036	0.040	0.044
F	3.36	3.56	3.76	0.132	0.140	0.148
G	0.34	0.44	0.54	0.013	0.017	0.021
H	2.42	2.54	2.66	0.095	0.100	0.105
I	1.15	1.27	1.39	0.045	0.050	0.055
theta 1	—	5°	—	—	5°	—
theta 2	—	2°	—	—	2°	—
theta 3	—	2°	—	—	2°	—

UTC UNISONIC TECHNOLOGIES CO., LTD.

DIMENSION

TO-92L DIMENSION (FIG. NO. DIM-TO92L-0002-A)

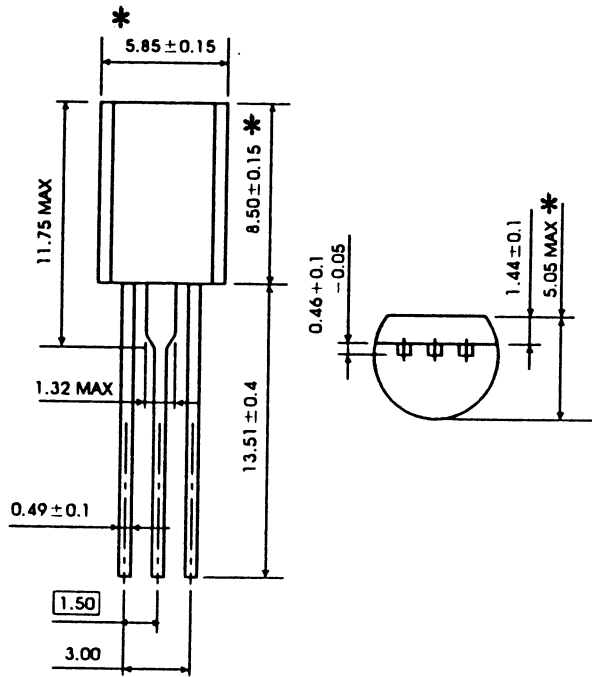

unit:mm

DIMENSION

TO-92M DIMENSION (FIG. NO. DIM-TO92M-0002-A)

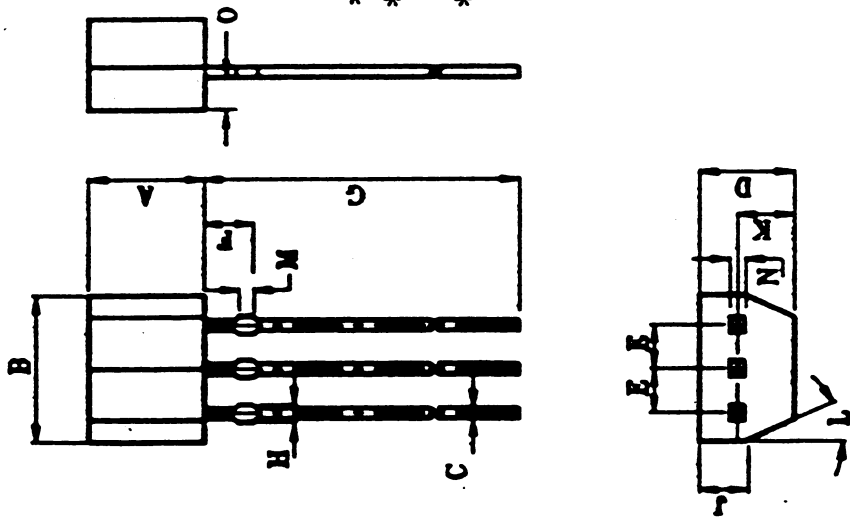

DIM	MILLIMETERS
A	3.20 MAX
B	4.30 MAX
C	0.55 MAX
D	2.40±0.16
E	1.27
F	2.30
G	14.00±0.50
H	0.60 MAX
J	1.05
K	1.45
L	25°
M	0.80
N	0.56 MAX
O	0.75

* * *

unit : mm

DIMENSION

TO-92SP DIMENSION (FIG. NO. DIM-TO92SP-0011-B)

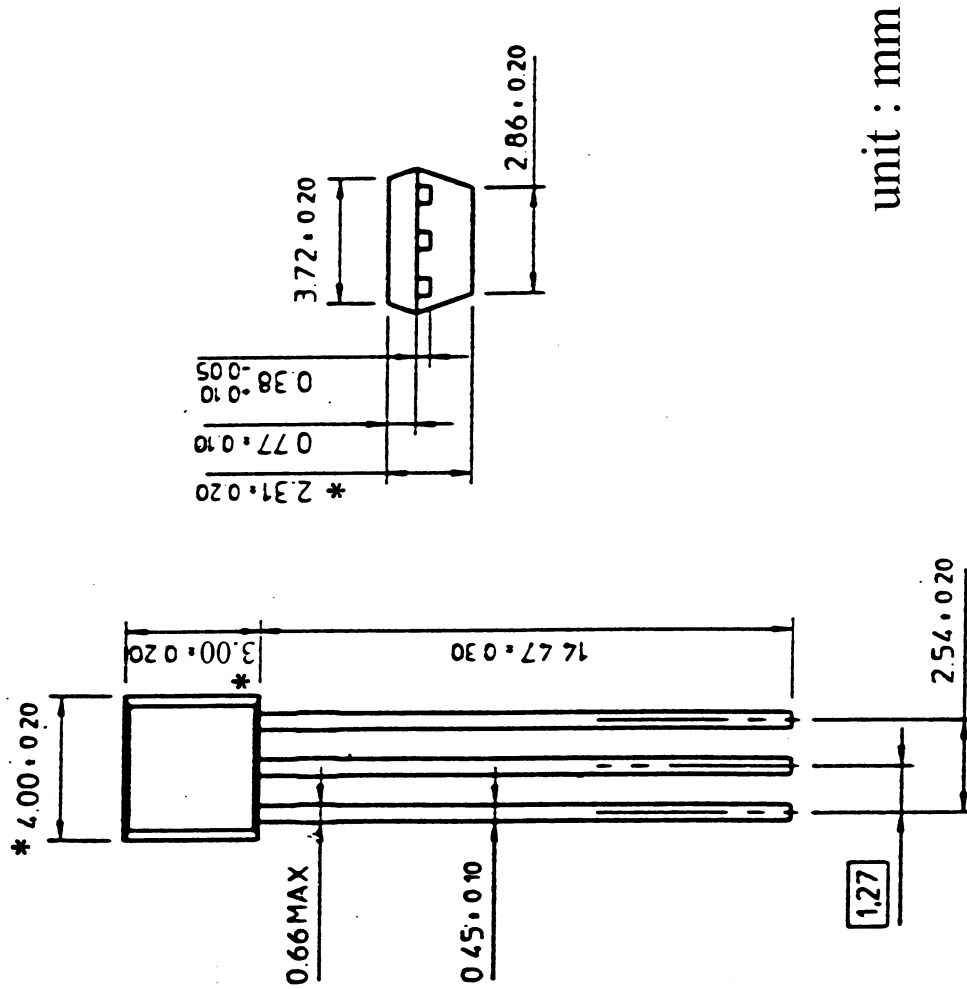

UTC UNISONIC TECHNOLOGIES CO., LTD.

DIMENSION

TO-92NL DIMENSION (FIG. NO. DIM-TO92NL-0103-B)

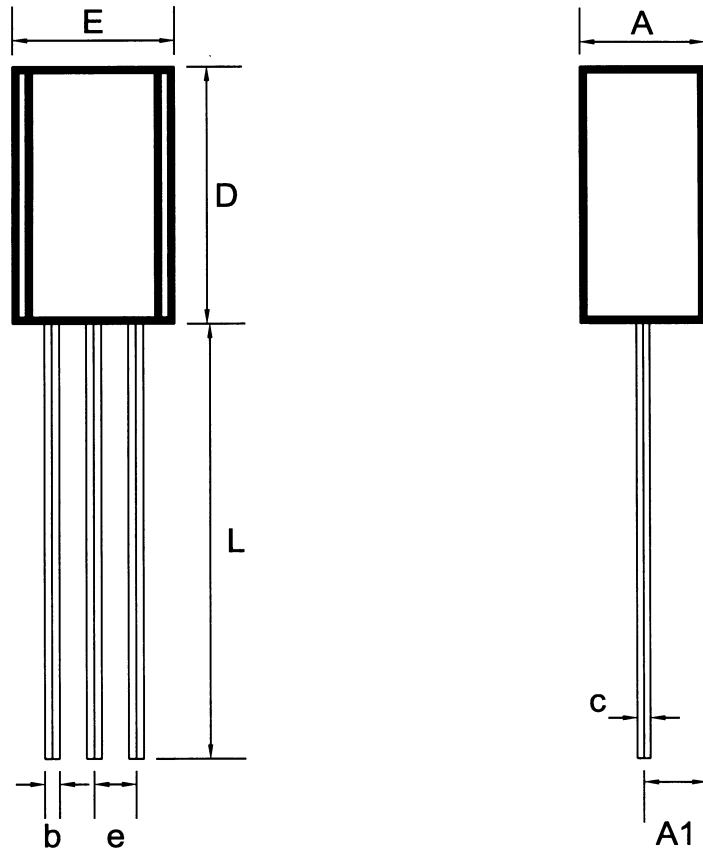

Symbol	Dimensions In Millimeters			Dimensions In Inches		
	Min	Nom	Max	Min	Nom	Max
A	3.60	3.80	4.00	0.142	0.150	0.157
A1	1.30	1.40	1.50	0.051	0.055	0.059
b	—	0.45	—	—	0.018	—
c	—	0.40	—	—	0.016	—
D	7.85	8.00	8.15	0.309	0.315	0.321
E	4.75	4.90	5.05	0.187	0.193	0.199
e	—	1.27	—	—	0.050	—
L	13.10	13.50	13.90	0.516	0.531	0.547

UTC UNISONIC TECHNOLOGIES CO., LTD.

DIMENSION

TO-126 DIMENSION (FIG. NO. DIM-TO126-0002-A)

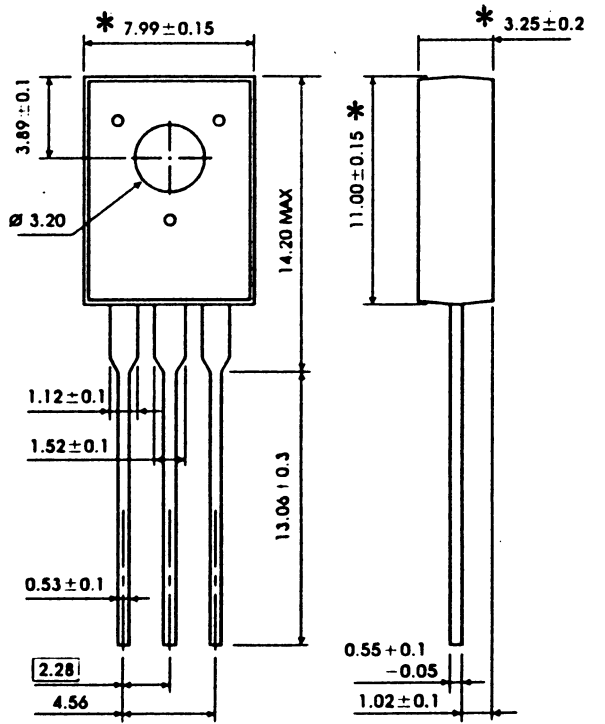

unit:mm

UTC UNISONIC TECHNOLOGIES CO., LTD.

DIMENSION

TO-220 DIMENSION (FIG. NO. DIM-TO220-0104-B)

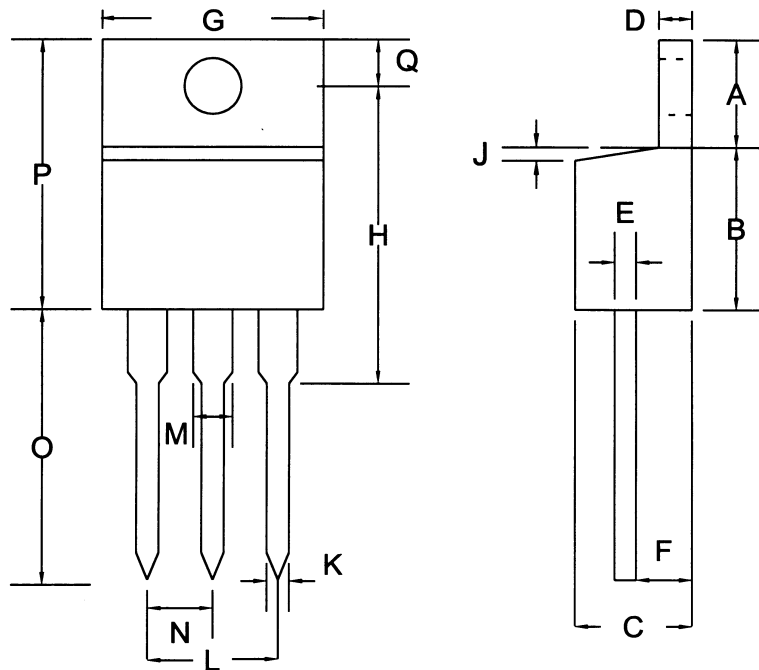

Symbol	Dimensions In Millimeters			Dimensions In Inches		
	Min	Nom	Max	Min	Nom	Max
A	5.58	6.54	7.49	0.220	0.257	0.295
B	8.38	8.64	8.90	0.330	0.340	0.350
C	4.07	4.45	4.82	0.160	0.175	0.190
D	1.15	1.27	1.39	0.045	0.050	0.055
E	0.35	0.45	0.60	0.014	0.018	0.024
F	2.04	2.42	2.79	0.080	0.095	0.110
G	9.66	9.97	10.28	0.380	0.393	0.405
H	—	16.25	—	—	0.640	—
I	3.68	3.83	3.98	0.145	0.151	0.157
J	—	—	1.27	—	—	0.050
K	0.75	0.85	0.95	0.030	0.033	0.037
L	4.83	5.08	5.33	0.190	0.200	0.210
M	1.15	1.33	1.52	0.045	0.052	0.060
N	2.42	2.54	2.66	0.095	0.100	0.105
O	12.70	13.48	14.27	0.500	0.531	0.562
P	14.48	15.17	15.87	0.570	0.597	0.625
Q	2.54	2.79	3.04	0.100	0.110	0.120

UTC UNISONIC TECHNOLOGIES CO., LTD.

DIMENSION

TO-220B DIMENSION (FIG. NO. DIM-TO220B-0002-A)

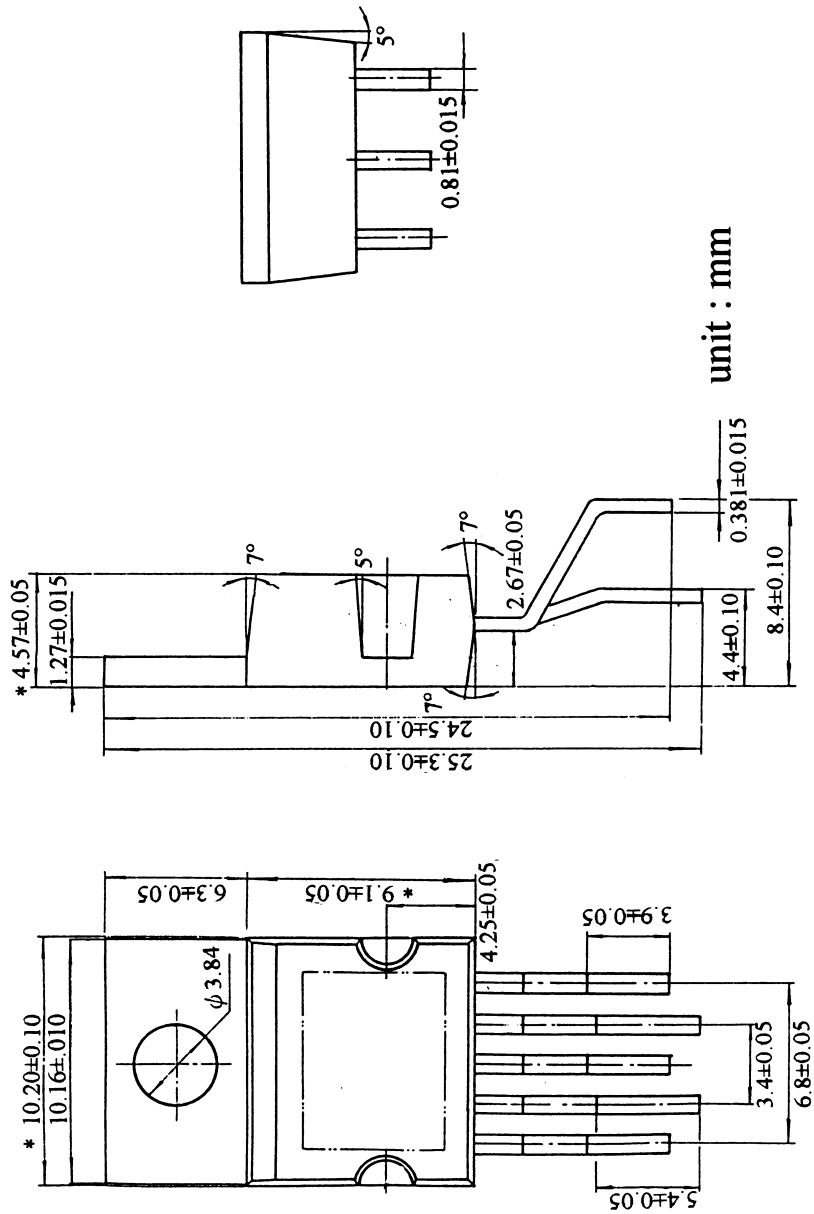

UTC UNISONIC TECHNOLOGIES CO., LTD.

DIMENSION

TO-220FP-4 DIMENSION (FIG. NO. DIM-TO220FP-0100-A)

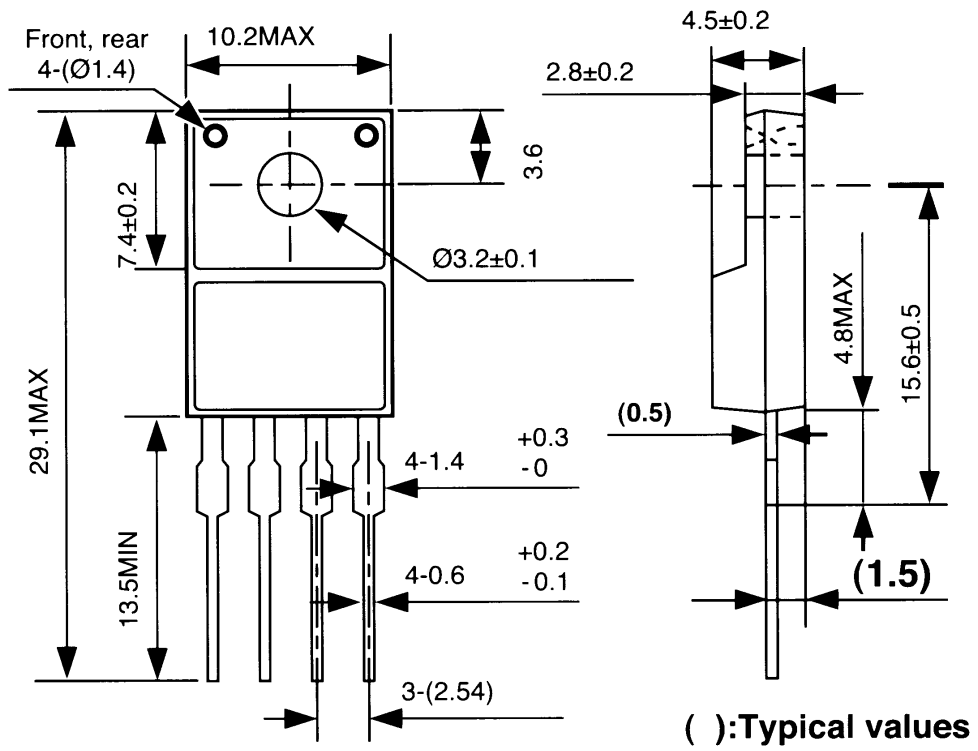

DIMENSION

TO-3 DIMENSION (FIG. NO. DIM-TO3-0002-A)

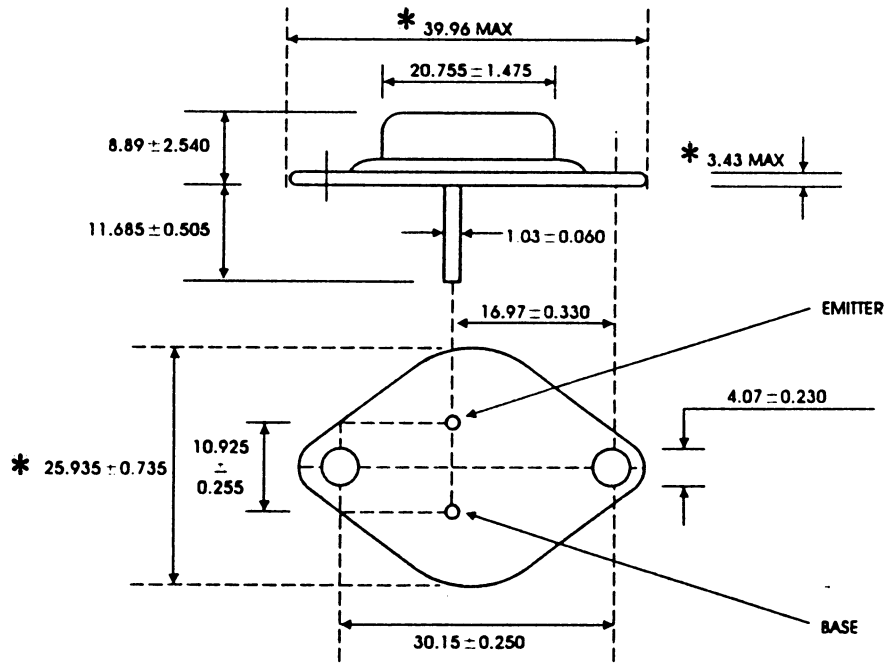

unit:mm

DIMENSION

TO-251 DIMENSION (FIG. NO. DIM-TO251-0002-A)

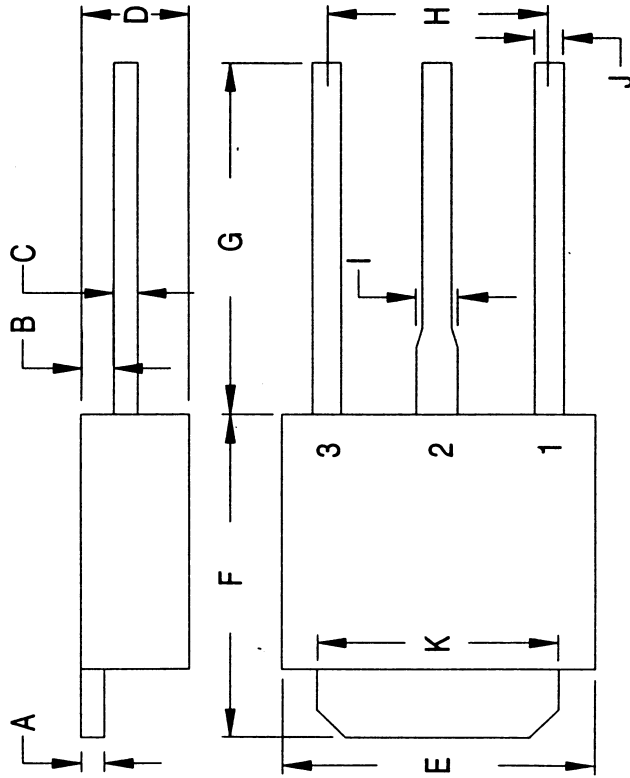

unit : mm

DIM	MIN.	MAX.
G	6.5	-
H	-	4.6
I	-	0.9
J	-	0.8
K	5.2	5.5

DIM	MIN.	MAX.
A	0.45	0.55
B	0.9	1.5
C	0.45	0.6
D	2.2	2.4
E	6.4	6.8
F	6.8	7.2

*

*

*

*

DIMENSION

TO-252 DIMENSION (FIG. NO. DIM-TO252-0009-B)

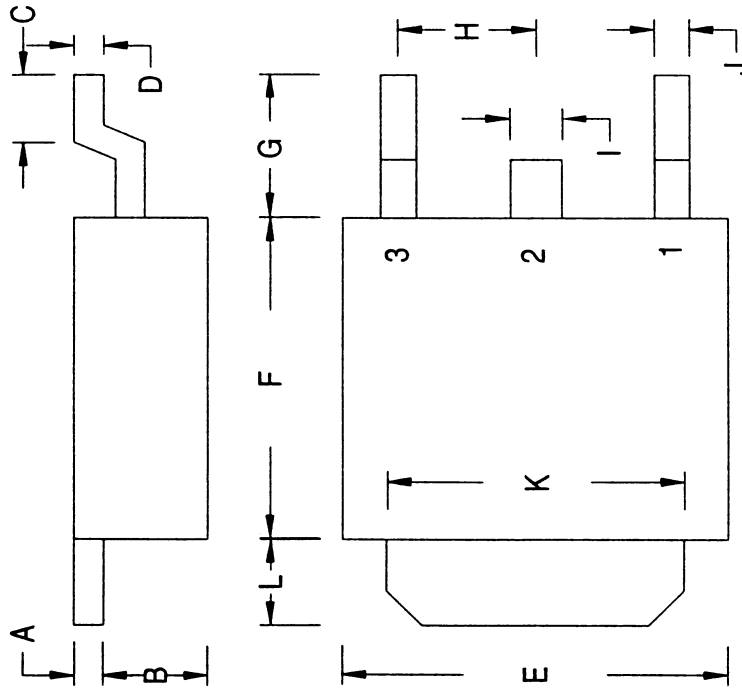

unit : mm

DIM	MIN	MAX
A	0.45	0.55
B	1.65	1.95
C	0.90	1.50
D	0.45	0.60
E	6.40	6.80
F	5.20	5.60
G	2.20	2.80
H	—	2.30
I	—	0.90
J	—	0.80
K	5.20	5.50
L	1.40	1.60

*

*

*

DIMENSION

TO-263 DIMENSION (FIG. NO. DIM-TO263-0002-A)

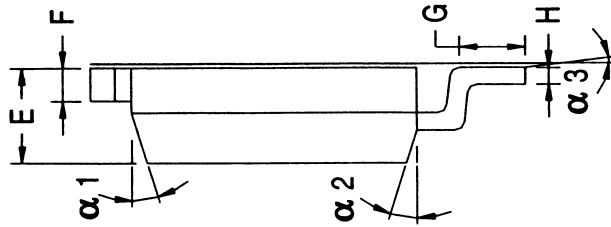

unit : mm

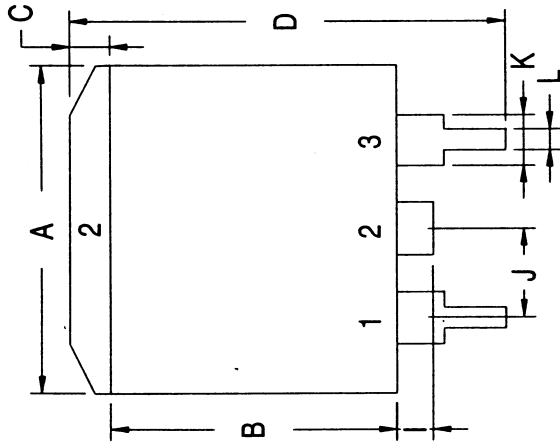

DIM	MIN.	MAX.
I	1.27	1.78
J	-	2.54
K	1.14	1.4
L	0.51	0.99
$\alpha 1$	6	8
$\alpha 2$	6	8
$\alpha 3$	0	5

DIM	MIN.	MAX.
A	9.65	10.29
B	8.38	9.4
C	-	1.4
D	14.61	15.88
E	4.06	4.83
F	1.14	1.4
G	2.29	2.79
H	0.46	0.74

*

*

*

*

DIMENSION

SOT-113 DIMENSION (FIG. NO. DIM-SOT113-0103-B)

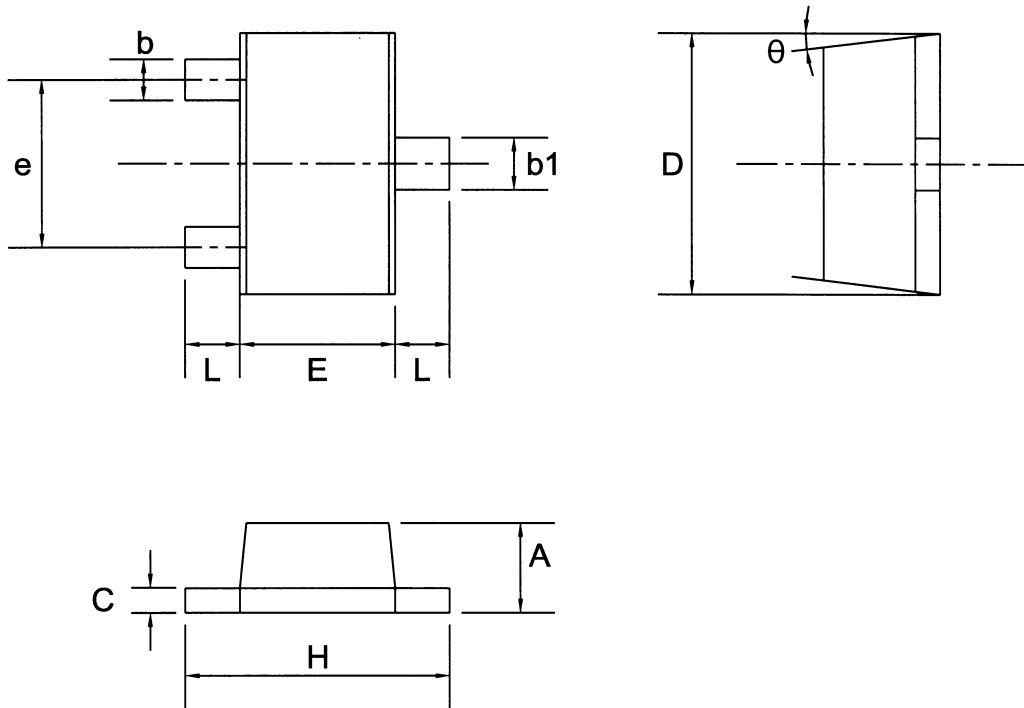

Symbol	Dimensions In Millimeters			Dimensions In Inches		
	Min	Nom	Max	Min	Nom	Max
A	0.56	0.61	0.66	0.022	0.024	0.026
b	0.19	0.22	0.25	0.007	0.009	0.010
b1	0.25	0.28	0.31	0.010	0.011	0.012
C	0.10	0.13	0.16	0.004	0.005	0.006
D	1.35	1.40	1.45	0.053	0.055	0.057
E	0.76	0.81	0.86	0.030	0.032	0.034
e	—	0.90	—	—	0.035	—
H	1.33	1.38	1.43	0.052	0.054	0.056
L	0.235	0.285	0.335	0.009	0.011	0.013
θ	0°	—	7°	0°	—	7°

UTC UNISONIC TECHNOLOGIES CO., LTD.

DIMENSION

SOT-223 DIMENSION (FIG. NO. DIM-SOT223-0103-B)

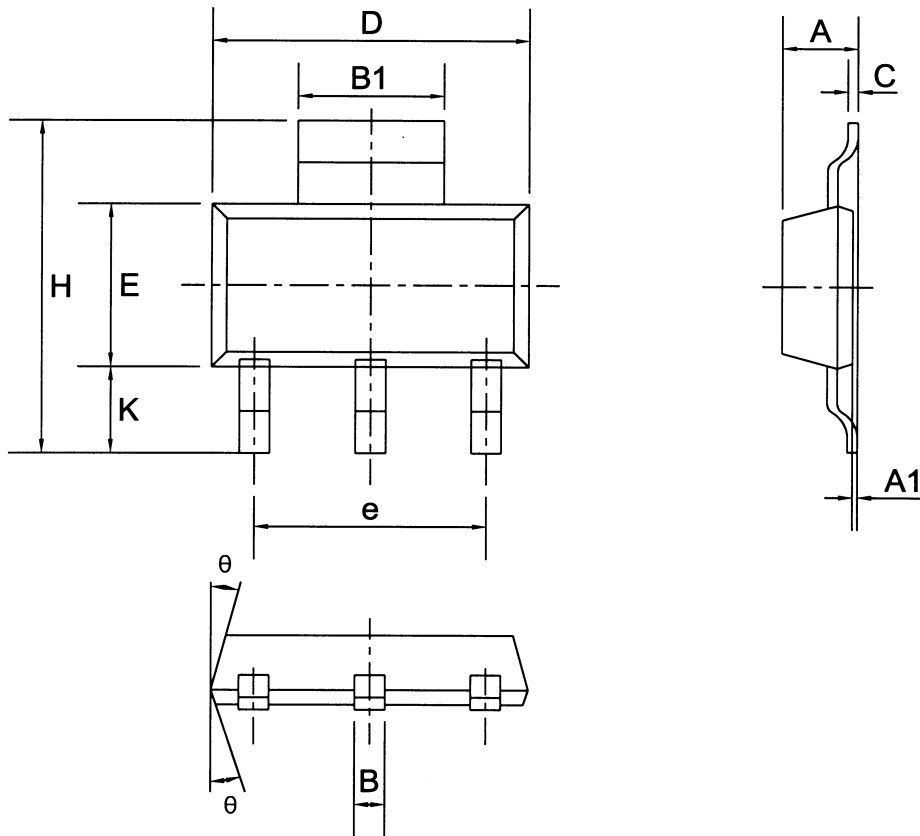

Symbol	Dimensions In Millimeters			Dimensions In Inches		
	Min	Nom	Max	Min	Nom	Max
A	1.50	1.65	1.80	0.059	0.065	0.071
A1	0.02	0.05	0.08	0.001	0.002	0.003
B	0.60	0.70	0.80	0.024	0.028	0.031
B1	2.90	3.00	3.15	0.114	0.118	0.124
C	0.28	0.30	0.32	0.011	0.012	0.013
D	6.30	6.50	6.70	0.248	0.256	0.264
E	3.30	3.50	3.70	0.130	0.138	0.146
e	—	4.60	—	—	0.181	—
H	6.70	7.00	7.30	0.264	0.276	0.287
K	1.50	1.75	2.00	0.059	0.069	0.079
theta	0°	—	13°	0°	—	13°

UTC UNISONIC TECHNOLOGIES CO., LTD.

DIMENSION

SOT-23 DIMENSION (FIG. NO. DIM-SOT23-0103-B)

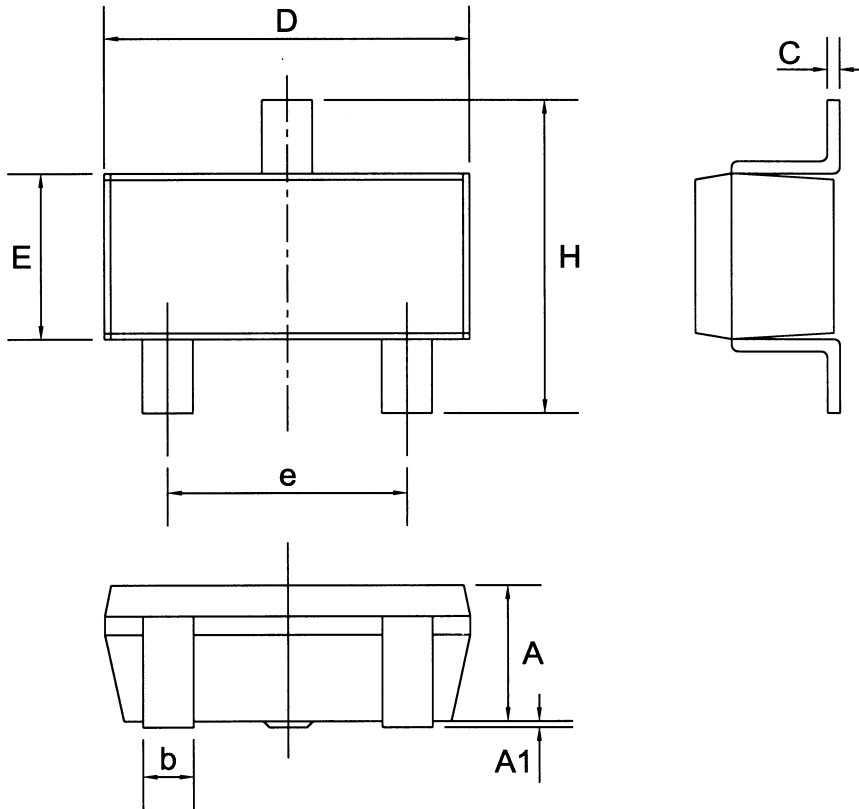

Symbol	Dimensions In Millimeters			Dimensions In Inches		
	Min	Nom	Max	Min	Nom	Max
A	1.05	1.15	1.35	0.041	0.045	0.053
A1	—	0.05	0.10	—	0.002	0.004
b	0.35	0.40	0.55	0.014	0.016	0.022
C	0.08	0.10	0.20	0.003	0.004	0.008
D	2.70	2.90	3.10	0.106	0.114	0.122
E	1.20	1.35	1.50	0.047	0.053	0.059
e	1.70	1.90	2.10	0.067	0.075	0.083
H	2.35	2.55	2.75	0.093	0.100	0.108

UTC UNISONIC TECHNOLOGIES CO., LTD.

DIMENSION

SOT-23 VERTICAL DIMENSION (FIG. NO. DIM-SOT23V-0103-B)

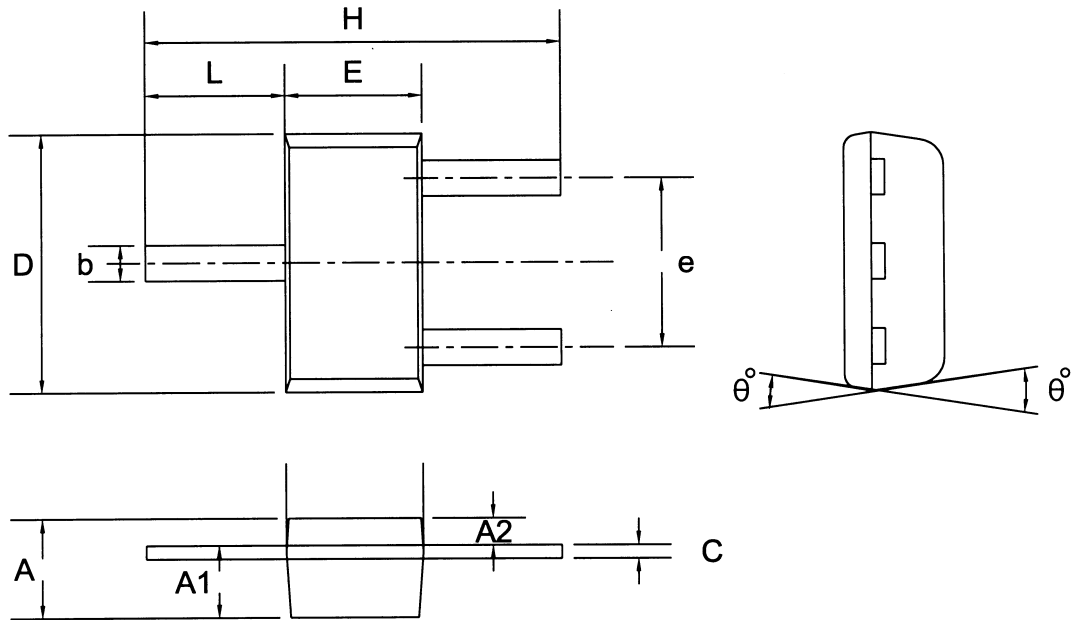

Symbol	Dimensions In Millimeters			Dimensions In Inches		
	Min	Nom	Max	Min	Nom	Max
A	1.02	1.10	1.18	0.040	0.043	0.046
A1	0.75	0.80	0.85	0.030	0.031	0.033
A2	0.25	0.30	0.35	0.010	0.012	0.014
b	0.30	0.40	0.50	0.012	0.016	0.020
C	0.05	0.15	0.25	0.002	0.006	0.010
D	2.80	2.90	3.00	0.110	0.114	0.118
E	1.45	1.50	1.55	0.057	0.059	0.061
e	1.70	1.90	2.10	0.067	0.075	0.083
H	—	4.65	—	—	0.183	—
L	1.52	—	—	0.060	—	—
θ	0°	—	10°	0°	—	10°

UTC UNISONIC TECHNOLOGIES CO., LTD.

DIMENSION

SOT-25 DIMENSION (FIG. NO. DIM-SOT25-0103-B)

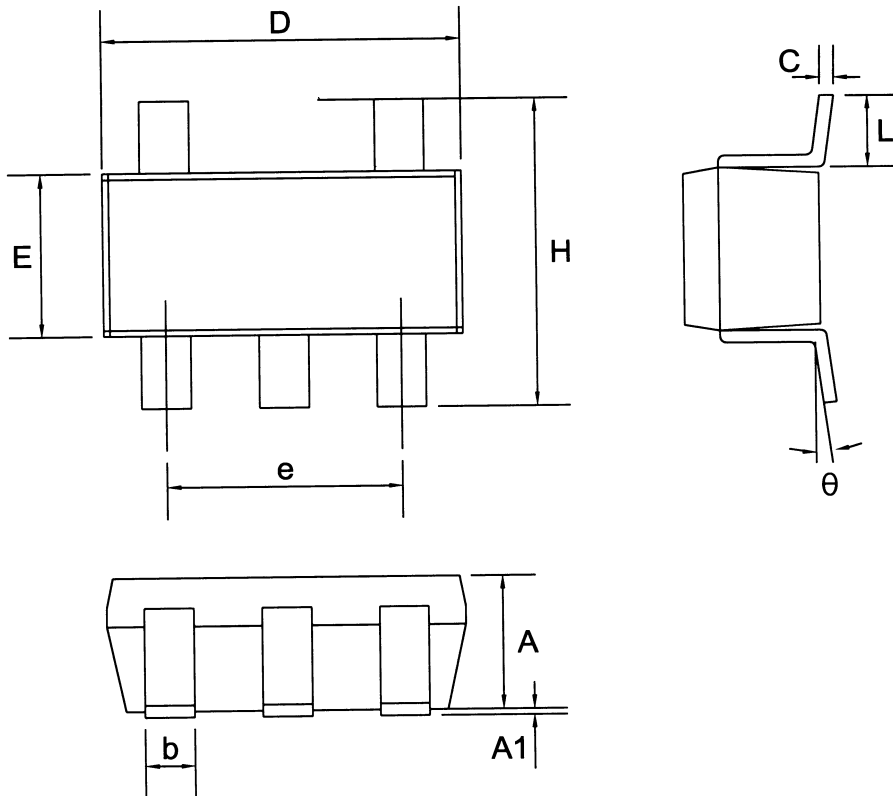

Symbol	Dimensions In Millimeters			Dimensions In Inches		
	Min	Nom	Max	Min	Nom	Max
A	1.00	1.10	1.20	0.039	0.043	0.047
A1	0.00	—	0.10	0.000	—	0.004
b	0.35	0.40	0.50	0.014	0.016	0.020
C	0.10	0.15	0.25	0.004	0.006	0.010
D	2.70	2.90	3.10	0.106	0.114	0.122
E	1.40	1.60	1.80	0.055	0.063	0.071
e	—	1.90	—	—	0.075	—
H	2.60	2.80	3.00	0.102	0.110	0.118
L	0.35	0.45	0.55	0.014	0.018	0.022
θ	0°	5°	10°	0°	5°	10°

UTC UNISONIC TECHNOLOGIES CO., LTD.

DIMENSION

SOT-89 DIMENSION (FIG. NO. DIM-SOT89-0103-B)

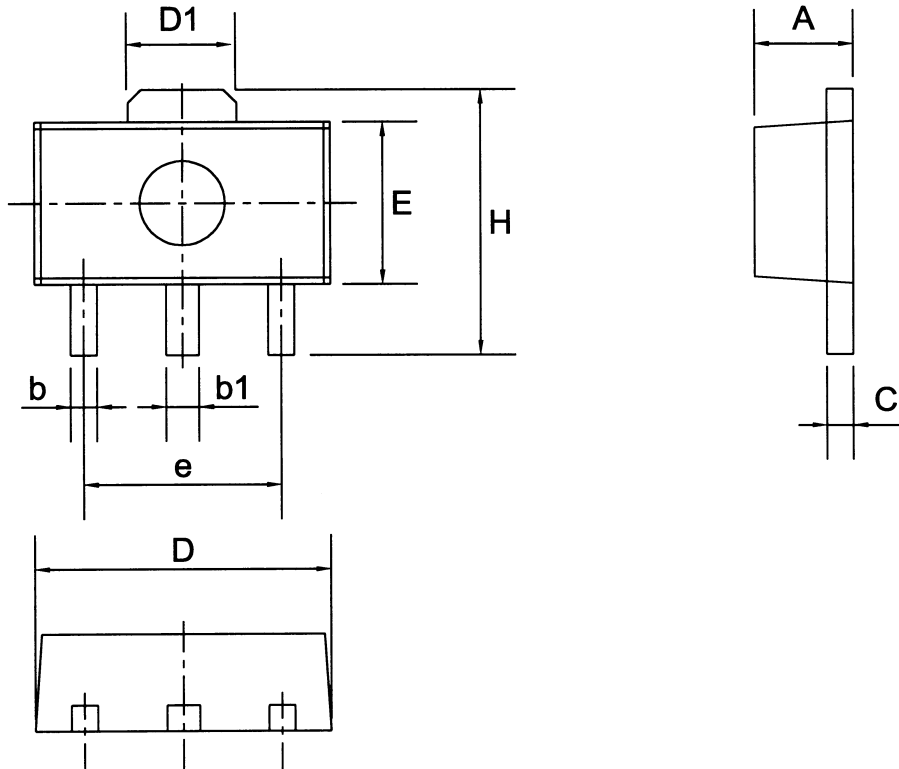

Symbol	Dimensions In Millimeters			Dimensions In Inches		
	Min	Nom	Max	Min	Nom	Max
A	1.30	1.50	1.70	0.051	0.059	0.067
b	0.25	0.40	0.55	0.010	0.016	0.022
b1	0.40	0.50	0.60	0.016	0.020	0.024
C	0.30	0.40	0.50	0.012	0.016	0.020
D	4.30	4.50	4.70	0.169	0.177	0.185
D1	1.45	1.65	1.85	0.057	0.065	0.073
E	2.30	2.50	2.70	0.091	0.098	0.106
e	2.90	3.00	3.10	0.114	0.118	0.122
H	3.90	4.10	4.30	0.154	0.161	0.169

UTC UNISONIC TECHNOLOGIES CO., LTD.

DIMENSION

TSSOP-8 DIMENSION (FIG. NO. DIM-TSSOP8-0103-B)

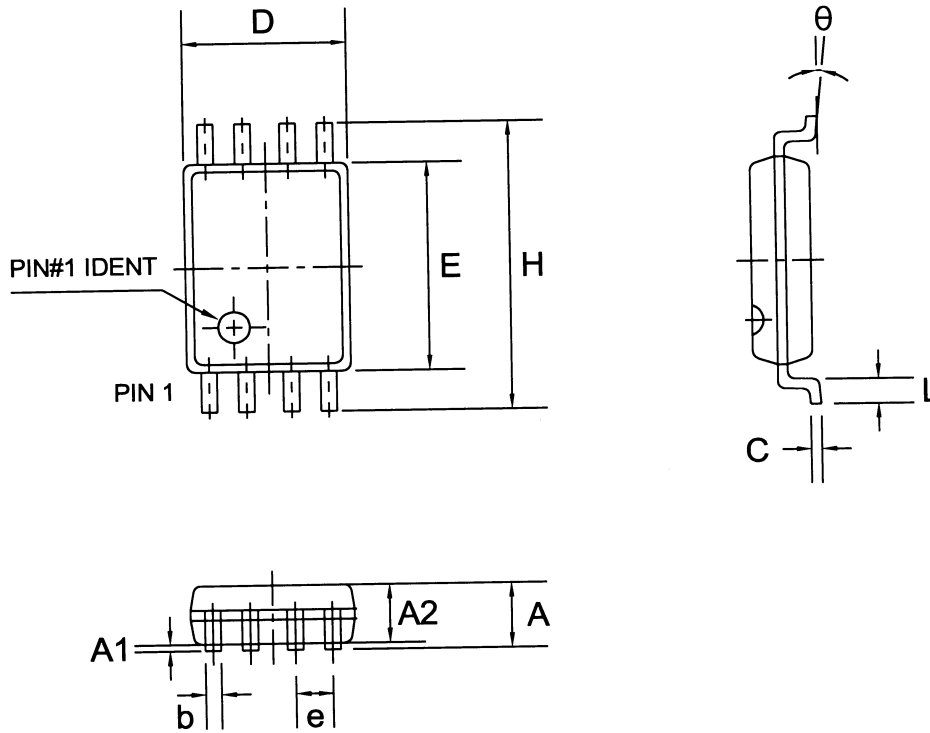

Symbol	Dimensions In Millimeters			Dimensions In Inches		
	Min	Nom	Max	Min	Nom	Max
A	1.05	1.10	1.20	0.041	0.043	0.047
A1	0.05	0.10	0.15	0.002	0.004	0.006
A2	0.90	1.00	1.10	0.035	0.039	0.043
b	—	0.27	—	—	0.011	—
C	—	0.127	—	—	0.005	—
D	2.90	3.05	3.10	0.114	0.120	0.122
E	4.30	4.40	4.50	0.169	0.173	0.177
e	—	0.65	—	—	0.026	—
H	6.20	6.40	6.60	0.244	0.252	0.260
L	0.50	0.60	0.70	0.020	0.024	0.028
θ	0°	—	8°	0°	—	8°

UTC UNISONIC TECHNOLOGIES CO., LTD.

DIMENSION

TAPING TO-92 DIMENSION (FIG. NO. DIM-TAPING-TO92-0105-C 1/2)

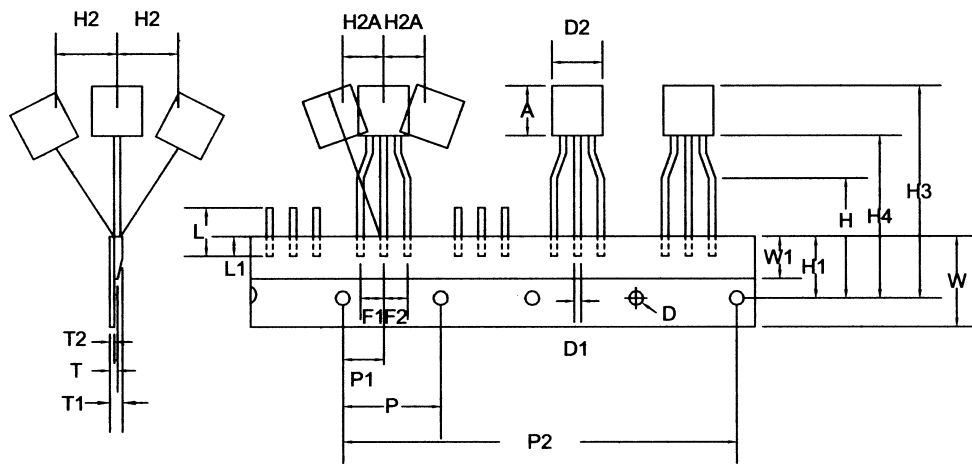
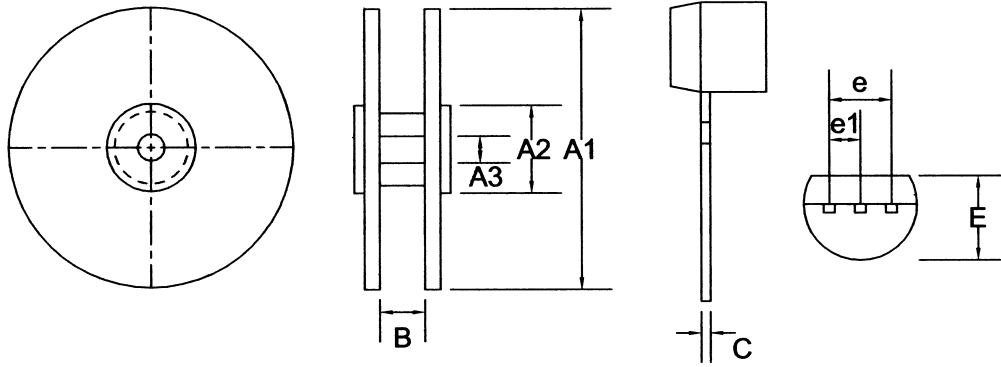

UTC UNISONIC TECHNOLOGIES CO., LTD.

DIMENSION

TAPING TO-92 DIMENSION (FIG. NO. DIM-TAPING-TO92-0105-C 2/2)

Symbol	Dimensions In Millimeters			Dimensions In Inches		
	Min	Nom	Max	Min	Nom	Max
A	4.33	4.58	4.83	0.170	0.180	0.190
A1	357.00	360.00	363.00	14.055	14.173	14.291
A2	89.00	90.00	91.00	3.504	3.543	3.583
A3	29.00	30.00	31.00	1.142	1.181	1.220
B	44.00	45.00	46.00	1.732	1.772	1.811
C	—	0.40	—	—	0.016	—
D	3.80	4.00	4.20	0.150	0.157	0.165
D1	0.36	0.44	0.53	0.014	0.017	0.021
D2	4.33	4.58	4.83	0.170	0.180	0.190
E	3.30	3.50	3.70	0.130	0.138	0.146
e	—	2.54	—	—	0.100	—
e1	—	1.27	—	—	0.050	—
F1,F2	2.40	2.65	2.90	0.094	0.104	0.114
F1-F2	-0.30	0.00	+0.30	-0.012	0.000	+0.012
H	15.50	16.00	16.50	0.610	0.630	0.650
H1	8.50	9.00	9.50	0.335	0.354	0.374
H2	—	—	1.00	—	—	0.039
H2A	—	—	1.00	—	—	0.039
H3	—	—	27.00	—	—	1.063
H4	—	—	21.00	—	—	0.827
L	—	—	11.00	—	—	0.433
L1	2.50	—	—	0.098	—	—
P	12.50	12.70	12.90	0.492	0.500	0.508
P1	5.95	6.35	6.75	0.234	0.250	0.266
P2	50.30	50.80	51.30	1.980	2.000	2.020
T	—	—	0.55	—	—	0.022
T1	—	—	1.42	—	—	0.056
T2	0.36	0.52	0.68	0.014	0.020	0.027
W	17.50	18.25	19.00	0.689	0.719	0.748
W1	5.00	6.00	7.00	0.197	0.236	0.276

UTC UNISONIC TECHNOLOGIES CO., LTD.

DIMENSION

TAPING SOP-8 DIMENSION (FIG. NO. DIM-TAPING-SOP8-0104-B)

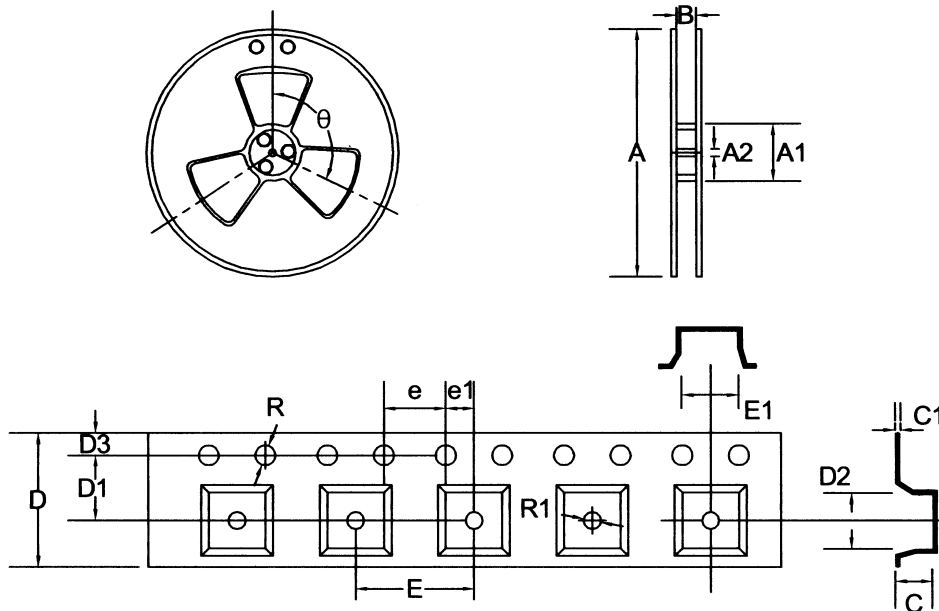

Symbol	Dimensions In Millimeters			Dimensions In Inches		
	Min	Nom	Max	Min	Nom	Max
A	327.00	330.00	333.00	12.874	12.992	13.110
A1	99.00	100.00	101.00	3.898	3.937	3.976
A2	13.30	13.50	13.70	0.524	0.531	0.539
B	12.20	12.50	12.80	0.480	0.492	0.504
C	2.01	2.11	2.21	0.079	0.083	0.087
C1	0.19	0.29	0.39	0.007	0.011	0.015
D	11.70	12.00	12.30	0.461	0.472	0.484
D1	5.45	5.50	5.55	0.215	0.217	0.219
D2	5.11	5.21	5.31	0.201	0.205	0.209
D3	1.65	1.75	1.85	0.065	0.069	0.073
E	7.90	8.00	8.10	0.311	0.315	0.319
E1	6.30	6.40	6.50	0.248	0.252	0.256
e	3.90	4.00	4.10	0.154	0.157	0.161
10e	39.80	40.00	40.20	1.567	1.575	1.583
e1	1.95	2.00	2.05	0.077	0.079	0.081
R	1.45	1.50	1.60	0.057	0.059	0.063
R1	1.45	1.50	1.75	0.057	0.059	0.069
θ	—	120°	—	—	120°	—

UTC UNISONIC TECHNOLOGIES CO., LTD.

DIMENSION

TAPING SOP-14 DIMENSION (FIG. NO. DIM-TAPING-SOP16-0104-B)

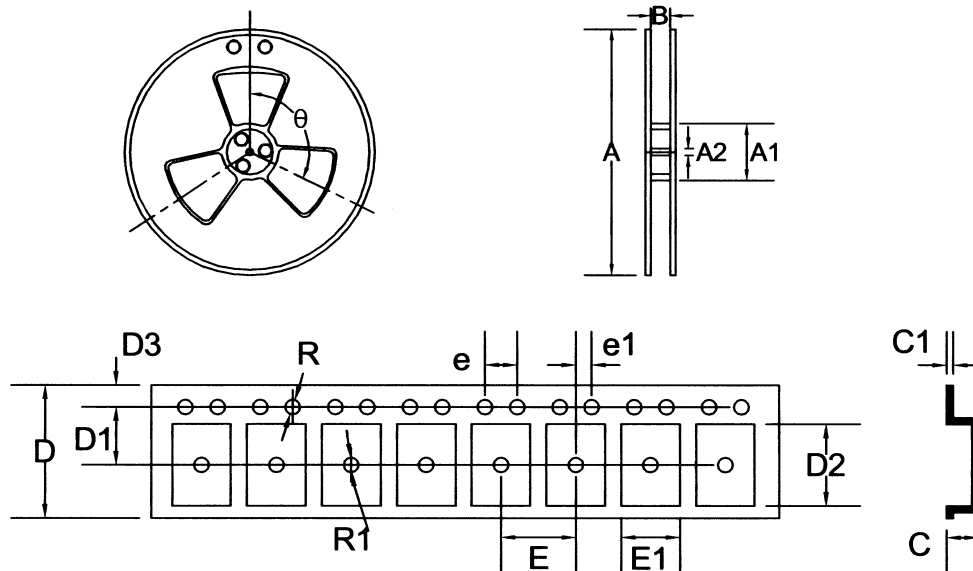

Symbol	Dimensions In Millimeters			Dimensions In Inches		
	Min	Nom	Max	Min	Nom	Max
A	327.00	330.00	333.00	12.874	12.992	13.110
A1	99.00	100.00	101.00	3.898	3.937	3.976
A2	13.30	13.50	13.70	0.524	0.531	0.539
B	16.20	16.50	16.80	0.638	0.650	0.661
C	2.00	2.10	2.20	0.079	0.083	0.087
C1	0.25	0.30	0.35	0.010	0.012	0.014
D	15.70	16.00	16.30	0.618	0.630	0.642
D1	7.40	7.50	7.60	0.291	0.295	0.299
D2	10.20	10.30	10.40	0.402	0.406	0.409
D3	1.65	1.75	1.85	0.065	0.069	0.073
E	7.90	8.00	8.10	0.311	0.315	0.319
E1	6.40	6.50	6.60	0.252	0.256	0.260
e	3.90	4.00	4.10	0.154	0.157	0.161
e1	1.90	2.00	2.10	0.075	0.079	0.083
R	1.45	1.50	1.60	0.057	0.059	0.063
R1	1.45	1.50	1.75	0.057	0.059	0.069
θ	—	120°	—	—	120°	—

UTC UNISONIC TECHNOLOGIES CO., LTD.

DIMENSION

TAPING SOP-16 DIMENSION (FIG. NO. DIM-TAPING-SOP16-0104-B)

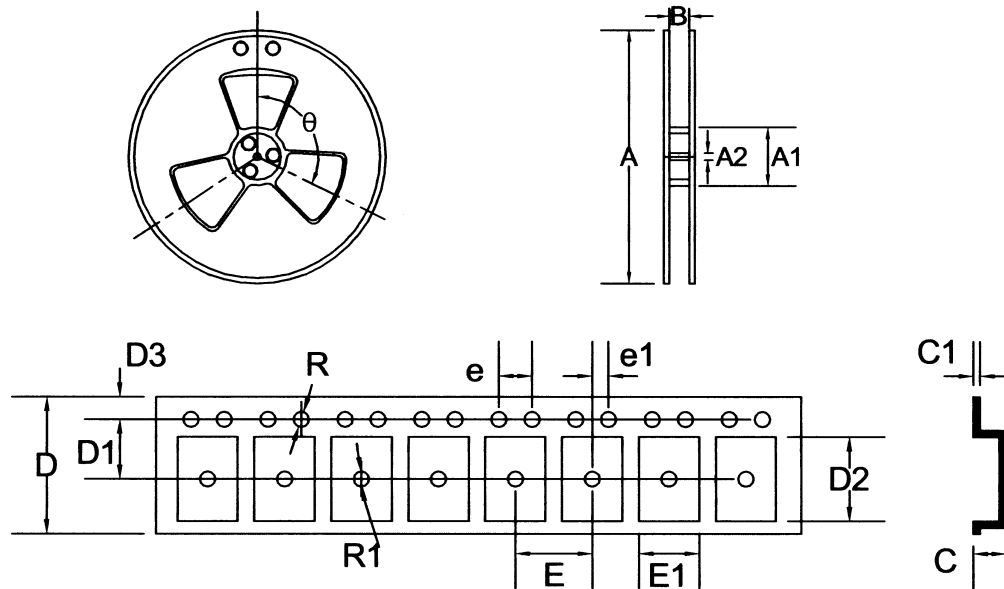

Symbol	Dimensions In Millimeters			Dimensions In Inches		
	Min	Nom	Max	Min	Nom	Max
A	327.00	330.00	333.00	12.874	12.992	13.110
A1	99.00	100.00	101.00	3.898	3.937	3.976
A2	13.30	13.50	13.70	0.524	0.531	0.539
B	16.20	16.50	16.80	0.638	0.650	0.661
C	2.00	2.10	2.20	0.079	0.083	0.087
C1	0.25	0.30	0.35	0.010	0.012	0.014
D	15.70	16.00	16.30	0.618	0.630	0.642
D1	7.40	7.50	7.60	0.291	0.295	0.299
D2	10.20	10.30	10.40	0.402	0.406	0.409
D3	1.65	1.75	1.85	0.065	0.069	0.073
E	7.90	8.00	8.10	0.311	0.315	0.319
E1	6.40	6.50	6.60	0.252	0.256	0.260
e	3.90	4.00	4.10	0.154	0.157	0.161
e1	1.90	2.00	2.10	0.075	0.079	0.083
R	1.45	1.50	1.60	0.057	0.059	0.063
R1	1.45	1.50	1.75	0.057	0.059	0.069
θ	—	120°	—	—	120°	—

UTC UNISONIC TECHNOLOGIES CO., LTD.

DIMENSION

TAPING SOP-28 DIMENSION (FIG. NO. DIM-TAPING-SOP28-0104-B)

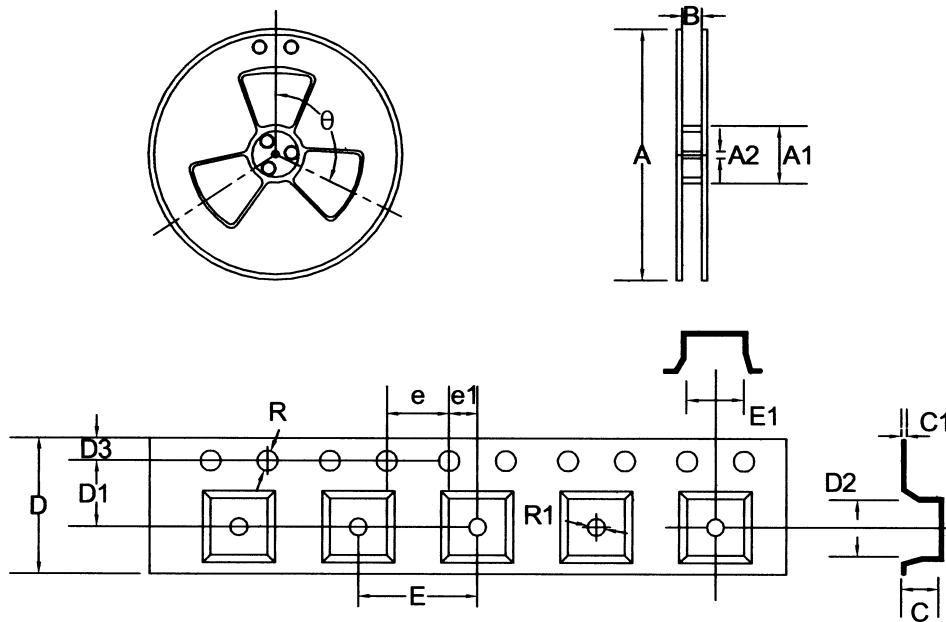

Symbol	Dimensions In Millimeters			Dimensions In Inches		
	Min	Nom	Max	Min	Nom	Max
A	327.00	330.00	333.00	12.874	12.992	13.110
A1	99.00	100.00	101.00	3.898	3.937	3.976
A2	13.30	13.50	13.70	0.524	0.531	0.539
B	24.20	24.50	24.80	0.953	0.965	0.976
C	2.87	2.97	3.07	0.113	0.117	0.121
C1	0.25	0.35	0.45	0.010	0.014	0.018
D	23.70	24.00	24.30	0.933	0.945	0.957
D1	11.40	11.50	11.60	0.449	0.453	0.457
D2	18.24	18.34	18.44	0.718	0.722	0.726
D3	1.65	1.75	1.85	0.065	0.069	0.073
E	11.90	12.00	12.10	0.469	0.472	0.476
E1	10.75	10.85	10.95	0.423	0.427	0.431
e	3.90	4.00	4.10	0.154	0.157	0.161
10e	39.80	40.00	40.20	1.567	1.575	1.583
e1	1.90	2.00	2.10	0.075	0.079	0.083
R	1.45	1.50	1.60	0.057	0.059	0.063
R1	1.45	1.50	1.75	0.057	0.059	0.069
θ	—	120°	—	—	120°	—

UTC UNISONIC TECHNOLOGIES CO., LTD.

DIMENSION

TAPING SOT-23 DIMENSION (FIG. NO. DIM-TAPING- SOT23-0104-B)

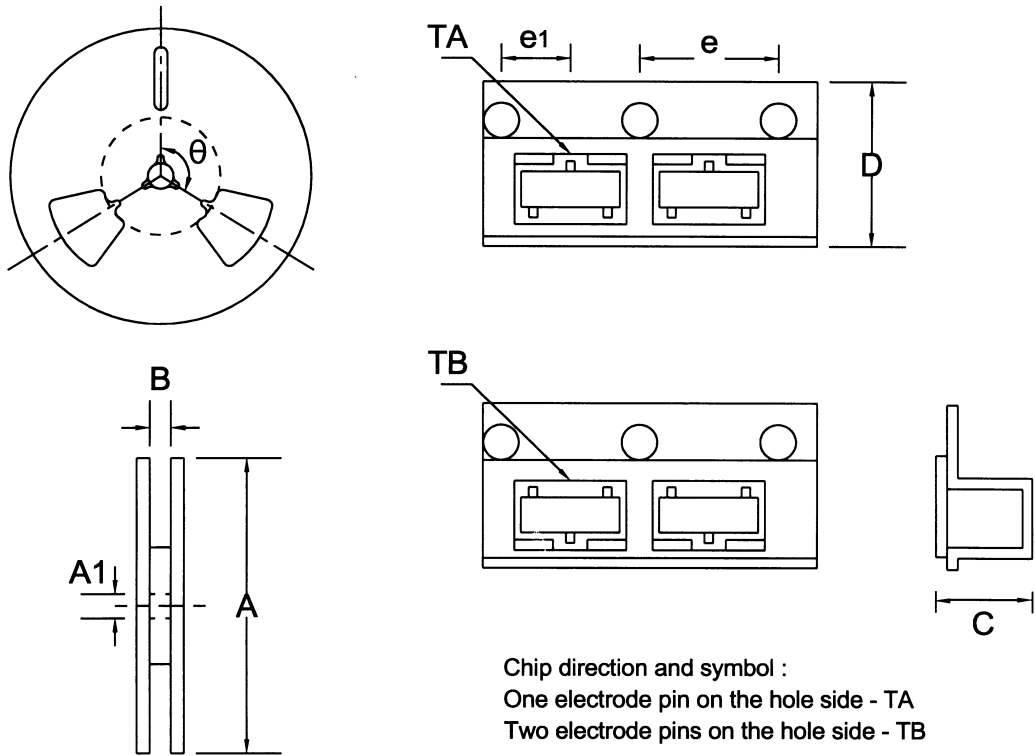

Chip direction and symbol :
 One electrode pin on the hole side - TA
 Two electrode pins on the hole side - TB

Symbol	Dimensions In Millimeters			Dimensions In Inches		
	Min	Nom	Max	Min	Nom	Max
A	176.00	178.00	180.00	6.929	7.008	7.087
A1	12.80	13.00	13.20	0.504	0.512	0.520
B	9.80	10.00	10.20	0.386	0.394	0.402
C	1.45	1.55	1.65	0.057	0.061	0.065
D	7.80	8.00	8.20	0.307	0.315	0.323
e	3.90	4.00	4.10	0.154	0.157	0.161
e1	1.90	2.00	2.10	0.075	0.079	0.083
θ	—	120°	—	—	120°	—

DIMENSION

TAPING SOT-223 DIMENSION (FIG. NO. DIM-TAPING-SOT223-0105-A)

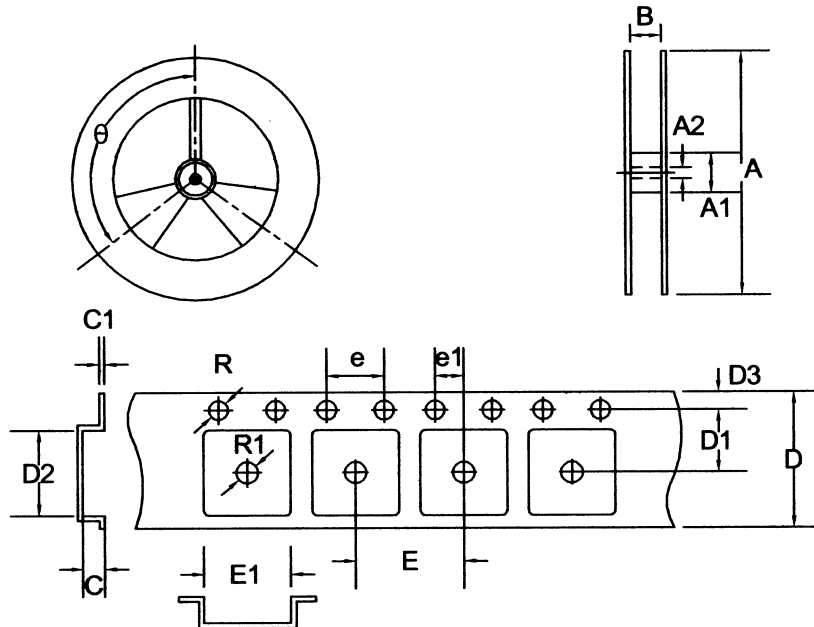

Symbol	Dimensions In Millimeters			Dimensions In Inches		
	Min	Nom	Max	Min	Nom	Max
A	416.00	420.00	424.00	16.378	16.535	16.693
A1	78.00	80.00	82.00	3.071	3.150	3.228
A2	12.50	13.00	13.50	0.492	0.512	0.531
B	12.50	13.50	14.50	0.492	0.531	0.571
C	2.00	2.10	2.20	0.079	0.083	0.087
C1	0.25	0.30	0.35	0.010	0.012	0.014
D	11.70	12.00	12.30	0.461	0.472	0.484
D1	5.40	5.50	5.60	0.213	0.217	0.220
D2	7.40	7.50	7.60	0.291	0.295	0.299
D3	1.65	1.75	1.85	0.065	0.069	0.073
E	7.90	8.00	8.10	0.311	0.315	0.319
E1	6.80	6.90	7.00	0.268	0.272	0.276
e	3.90	4.00	4.10	0.154	0.157	0.161
e1	1.90	2.00	2.10	0.075	0.079	0.083
R	1.45	1.50	1.60	0.057	0.059	0.063
R1	1.45	1.50	1.60	0.057	0.059	0.063
θ	—	120°	—	—	120°	—

UTC UNISONIC TECHNOLOGIES CO., LTD.

DIMENSION

TAPING SOT-25 DIMENSION (FIG. NO. DIM-TAPING-SOT25/26-0105-A)

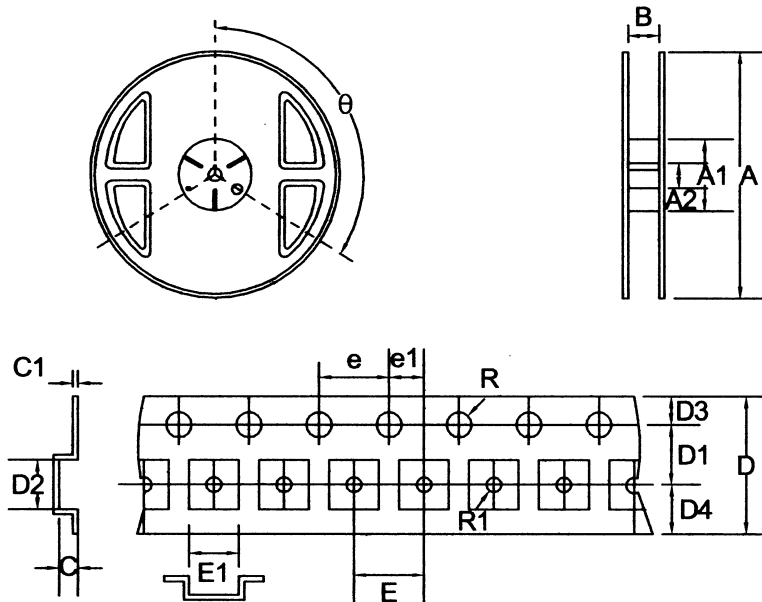

Symbol	Dimensions in Millimeters			Dimensions in Inches		
	Min	Nom	Max	Min	Nom	Max
A	178.00	180.00	182.00	7.008	7.087	7.165
A1	59.00	60.00	61.00	2.323	2.362	2.402
A2	12.80	13.00	13.20	0.504	0.512	0.520
B	8.70	9.00	9.30	0.343	0.354	0.366
C	1.40	1.50	1.60	0.055	0.059	0.063
C1	0.20	0.25	0.30	0.008	0.010	0.012
D	7.80	8.00	8.20	0.307	0.315	0.323
D1	3.45	3.50	3.55	0.136	0.138	0.140
D2	3.10	3.20	3.30	0.122	0.126	0.130
D3	1.65	1.75	1.85	0.065	0.069	0.073
D4	2.65	2.75	2.85	0.104	0.108	0.112
E	3.90	4.00	4.10	0.154	0.157	0.161
E1	3.20	3.30	3.40	0.126	0.130	0.134
e	3.90	4.00	4.10	0.154	0.157	0.161
e1	1.90	2.00	2.10	0.075	0.079	0.083
R	1.45	1.50	1.60	0.057	0.059	0.063
R1	1.00	1.10	1.20	0.039	0.043	0.047
θ	—	120°	—	—	120°	—

UTC UNISONIC TECHNOLOGIES CO., LTD.

DIMENSION

TAPING SOT-26 DIMENSION (FIG. NO. DIM-TAPING-SOT25/26-0105-A)

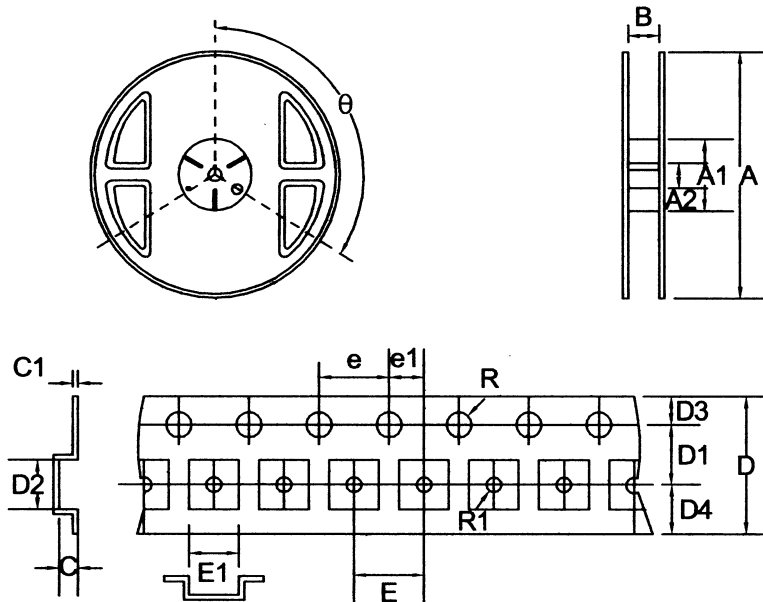

Symbol	Dimensions In Millimeters			Dimensions In Inches		
	Min	Nom	Max	Min	Nom	Max
A	178.00	180.00	182.00	7.008	7.087	7.165
A1	59.00	60.00	61.00	2.323	2.362	2.402
A2	12.80	13.00	13.20	0.504	0.512	0.520
B	8.70	9.00	9.30	0.343	0.354	0.366
C	1.40	1.50	1.60	0.055	0.059	0.063
C1	0.20	0.25	0.30	0.008	0.010	0.012
D	7.80	8.00	8.20	0.307	0.315	0.323
D1	3.45	3.50	3.55	0.136	0.138	0.140
D2	3.10	3.20	3.30	0.122	0.126	0.130
D3	1.65	1.75	1.85	0.065	0.069	0.073
D4	2.65	2.75	2.85	0.104	0.108	0.112
E	3.90	4.00	4.10	0.154	0.157	0.161
E1	3.20	3.30	3.40	0.126	0.130	0.134
e	3.90	4.00	4.10	0.154	0.157	0.161
e1	1.90	2.00	2.10	0.075	0.079	0.083
R	1.45	1.50	1.60	0.057	0.059	0.063
R1	1.00	1.10	1.20	0.039	0.043	0.047
θ	—	120°	—	—	120°	—

UTC UNISONIC TECHNOLOGIES CO., LTD.

DIMENSION

TAPING SOT-89 DIMENSION (FIG. NO. DIM-TAPING-SOT89-0104-B)

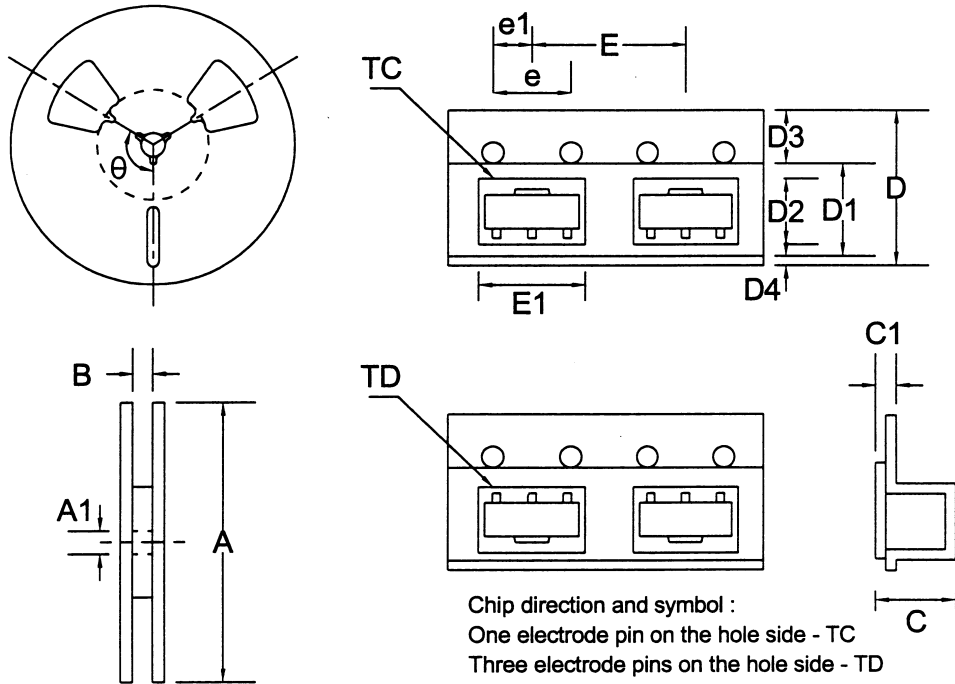

Symbol	Dimensions In Millimeters			Dimensions In Inches		
	Min	Nom	Max	Min	Nom	Max
A	176.00	178.00	180.00	6.929	7.008	7.087
A1	12.80	13.00	13.20	0.504	0.512	0.520
B	13.80	14.00	14.20	0.543	0.551	0.559
C	1.80	1.90	2.00	0.071	0.075	0.079
C1	0.35	0.40	0.45	0.014	0.016	0.018
D	11.70	12.00	12.30	0.460	0.472	0.484
D1	9.30	9.50	9.70	0.366	0.374	0.382
D2	4.40	4.50	4.60	0.173	0.177	0.181
D3	1.40	1.50	1.60	0.055	0.060	0.063
D4	0.45	0.50	0.55	0.018	0.020	0.022
E	7.90	8.00	8.10	0.311	0.315	0.319
E1	4.80	4.90	5.00	0.189	0.193	0.197
e	3.90	4.00	4.10	0.154	0.157	0.161
e1	1.90	2.00	2.10	0.075	0.079	0.083
θ	—	120°	—	—	120°	—

DIMENSION

TAPING TO-252 DIMENSION (FIG. NO. DIM-TAPING-TO252-0104-B)

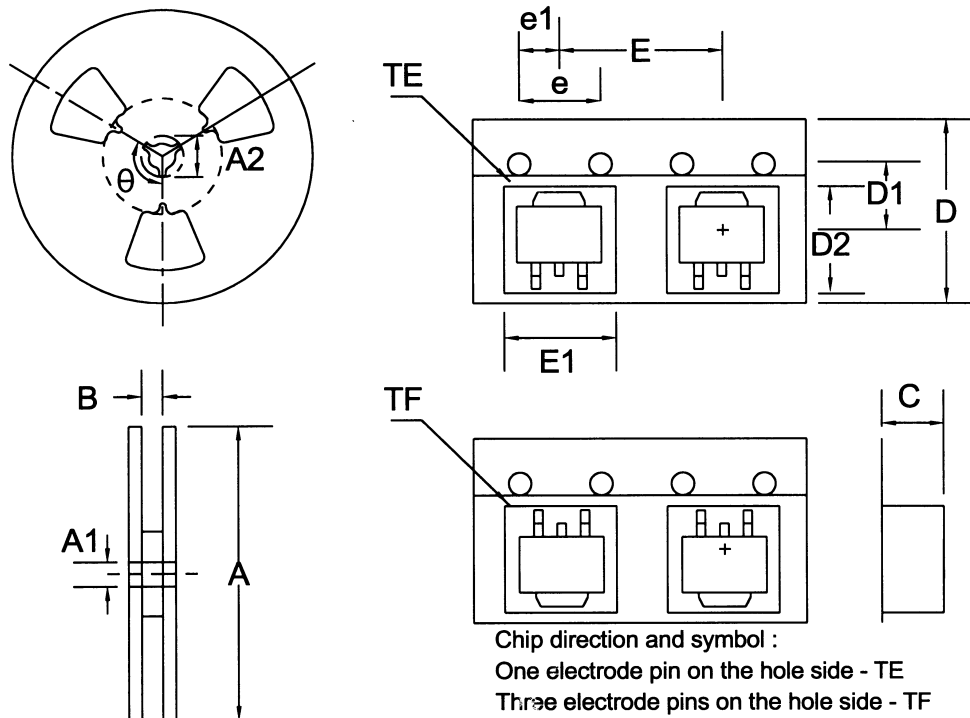

Symbol	Dimensions In Millimeters			Dimensions In Inches		
	Min	Nom	Max	Min	Nom	Max
A	327.00	330.00	333.00	12.874	12.992	13.110
A1	12.80	13.00	13.20	0.504	0.512	0.520
A2	20.20	—	—	0.795	—	—
B	17.00	17.50	18.00	0.669	0.689	0.709
C	2.69	2.79	2.89	0.106	0.110	0.114
D	15.70	16.00	16.30	0.618	0.630	0.642
D1	7.40	7.50	7.60	0.291	0.295	0.299
D2	10.29	10.49	10.69	0.405	0.413	0.421
E	7.90	8.00	8.10	0.311	0.315	0.319
E1	6.86	6.96	7.06	0.270	0.274	0.278
e	3.90	4.00	4.10	0.154	0.157	0.161
e1	1.90	2.00	2.10	0.075	0.079	0.083
θ	—	120°	—	—	120°	—

UTC UNISONIC TECHNOLOGIES CO., LTD.

DIMENSION

TAPING TO-263 DIMENSION (FIG. NO. DIM-TAPING-TO263-0105-A)

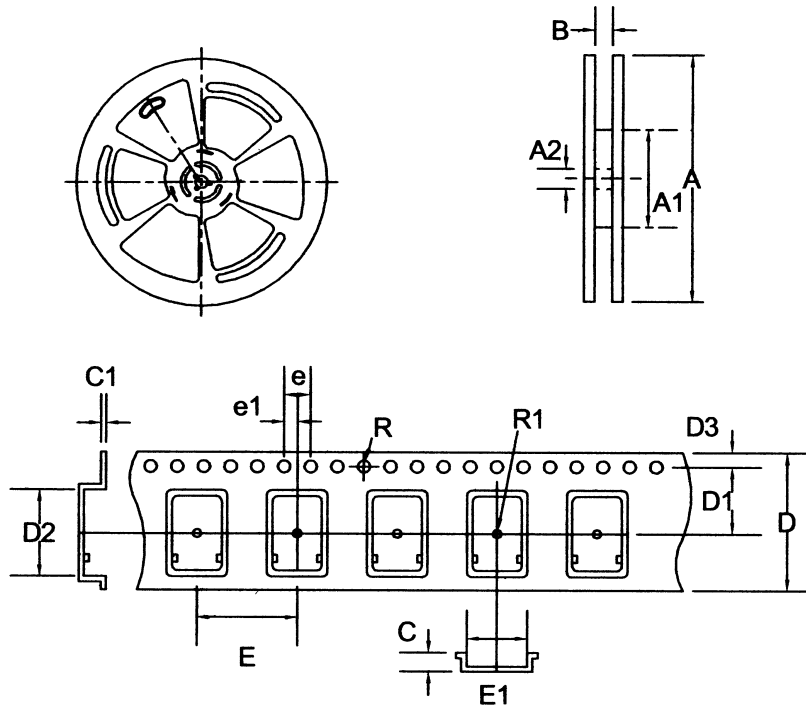

Symbol	Dimensions In Millimeters			Dimensions In Inches		
	Min	Nom	Max	Min	Nom	Max
A	377.00	380.00	383.00	14.843	14.961	15.079
A1	96.00	97.00	98.00	3.780	3.819	3.858
A2	12.50	13.00	13.50	0.492	0.512	0.531
B	20.00	24.00	28.00	0.787	0.945	1.102
C	4.80	4.90	5.00	0.189	0.193	0.197
C1	0.30	0.35	0.40	0.012	0.014	0.016
D	23.70	24.00	24.30	0.933	0.945	0.957
D1	11.35	11.50	11.65	0.447	0.453	0.459
D2	15.80	15.90	16.00	0.622	0.626	0.630
D3	1.65	1.75	1.85	0.065	0.069	0.073
E	15.90	16.00	16.10	0.626	0.630	0.634
E1	10.70	10.80	10.90	0.421	0.425	0.429
e	3.90	4.00	4.10	0.154	0.157	0.161
e1	1.85	2.00	2.15	0.073	0.079	0.085
R	1.45	1.50	1.60	0.057	0.059	0.063
R1	1.90	2.00	2.10	0.075	0.079	0.083

UTC UNISONIC TECHNOLOGIES CO., LTD.

DIMENSION

TAPING TSSOP-8 DIMENSION (FIG. NO. DIM-TAPING-TSSOP8-0105-A)

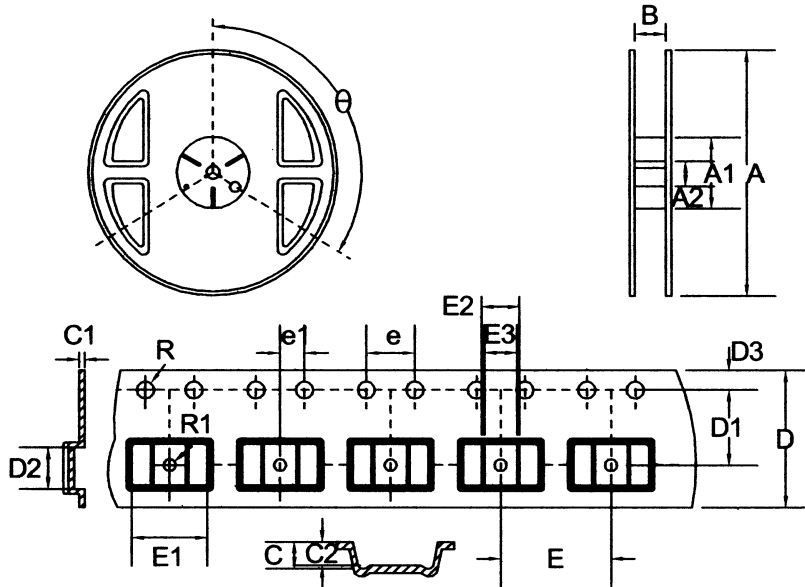

Symbol	Dimensions In Millimeters			Dimensions In Inches		
	Min	Nom	Max	Min	Nom	Max
A	178.00	180.00	182.00	7.008	7.087	7.165
A1	59.00	60.00	61.00	2.323	2.362	2.402
A2	12.80	13.00	13.20	0.504	0.512	0.520
B	11.00	12.00	13.00	0.433	0.472	0.512
C	1.50	1.60	1.70	0.060	0.063	0.067
C1	0.25	0.30	0.35	0.010	0.012	0.014
C2	1.20	1.30	1.40	0.047	0.051	0.055
D	11.70	12.00	12.30	0.461	0.472	0.484
D1	5.40	5.50	5.60	0.213	0.217	0.220
D2	3.30	3.40	3.50	0.130	0.134	0.138
D3	1.65	1.75	1.85	0.065	0.069	0.073
E	7.90	8.00	8.10	0.311	0.315	0.319
E1	6.70	6.80	6.90	0.264	0.268	0.272
E2	4.30	4.40	4.50	0.170	0.173	0.177
E3	3.70	3.80	3.90	0.146	0.150	0.154
e	3.90	4.00	4.10	0.154	0.157	0.161
e1	1.90	2.00	2.10	0.075	0.079	0.083
R	1.45	1.50	1.60	0.057	0.059	0.063
R1	1.45	1.50	1.60	0.057	0.059	0.063
theta	—	120°	—	—	120°	—

UTC UNISONIC TECHNOLOGIES CO., LTD.