

FEATURES

- Versatile analog signal conditioning circuitry
- On-board reference options
- Standalone capability only

DESCRIPTION

This document describes the EVAL-AD7993/AD7994CB, evaluation boards for the AD7993/AD7994 family of 10-bit and 12-bit analog-to-digital converters (ADCs).

The EVAL-AD7993/AD7994CB are standalone evaluation boards used to apply external control signals to configure the AD7993/AD7994. On-board components include an AD780, a

pin-programmable 2.5 V or 3 V ultrahigh precision band gap reference, and a REF192 2.5 V reference. The board also provides an AD713 op amp and inverters on the interface lines.

The AD7993/AD7994 products feature a low power, I²C-compatible successive approximation based architecture, operating from a single 3 V or 5 V supply with a throughput rate up to 188 kSPS. The evaluation board can be used to demonstrate the performance and functionality of the AD7993/AD7994 in a variety of applications.

The AD7993 and AD7994 data sheets should be used in conjunction with this document. The data sheets can be downloaded from www.analog.com.

FUNCTIONAL BLOCK DIAGRAM

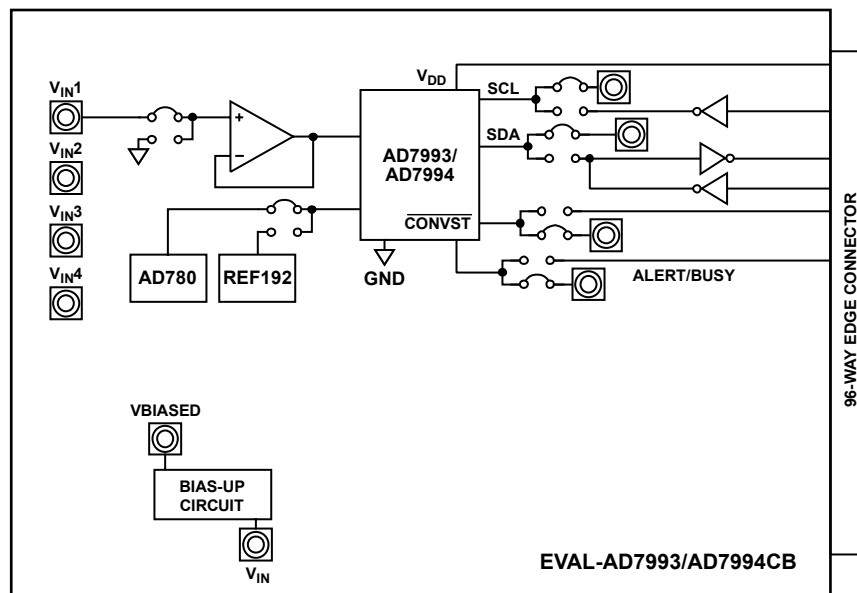

Figure 1.

Rev. 0

Evaluation boards are only intended for device evaluation and not for production purposes. Evaluation boards as supplied "as is" and without warranties of any kind, express, implied, or statutory including, but not limited to, any implied warranty of merchantability or fitness for a particular purpose. No license is granted by implication or otherwise under any patents or other intellectual property by application or use of evaluation boards. Information furnished by Analog Devices is believed to be accurate and reliable. However, no responsibility is assumed by Analog Devices for its use, nor for any infringements of patents or other rights of third parties that may result from its use. Analog Devices reserves the right to change devices or specifications at any time without notice. Trademarks and registered trademarks are the property of their respective owners. Evaluation boards are not authorized to be used in life support devices or systems.

TABLE OF CONTENTS

Features	1	Default Link Positions	4
Description	1	Evaluation Board Interfacing	5
Functional Block Diagram	1	Sockets	6
Revision History	2	Schematics	7
Operating the EVAL-AD7993/AD7994CB	3	Ordering Information	11
Initial Setup Conditions	4	Bill of Materials	11
Analog Input Ranges	4	Ordering Guide	12

REVISION HISTORY

12/06—Revision 0: Initial Version

OPERATING THE EVAL-AD7993/AD7994CB

The EVAL-AD7993/AD7994CB has several link options that can be used to control and configure the AD7993/AD7994. These options must be set for the required operating configuration before using the evaluation board. Table 1 outlines the functions of the link options.

Table 1.

Link No.	Function
LK1 to LK4	Allow the user to connect the inputs of the AD713 to the input sockets (V_{IN1} to V_{IN4}) or tie the AD713 inputs to AGND. In Position A, the relevant AD713 input is connected to the relevant input socket. In Position B, the relevant AD713 input is connected to AGND.
LK5	Selects the source of the SCL clock to be fed into the SCL pin of the AD7993/AD7994. In Position A, the SCL signal comes from the SMB SCL socket. In Position B, the SCL signal comes from the 74HC05, whose input signal in turn is chosen by LK17.
LK6	Selects the source/destination of the SDA signal to/from the SDA pin of the AD7993/AD7994. When in Position A, the SDA signal comes from/goes to the SMB SDA socket. When in Position B, the SDA signal comes from/goes to the 74HC05 chip, whose input/output signal in turn is chosen by LK18 and LK19.
LK7	This link option is used to select the destination of the BUSY/ALERT signal. When in Position A, the BUSY/ALERT signal is fed to the SMB ALERT socket. When in Position B, the BUSY/ALERT signal is fed to the 74HC05, where the inverted output is fed to the 96-way connector.
LK8	Selects the source of the SDA signal to be fed into the 74HC05. When in Position A, the SDA signal comes from the 96-way connector. When in Position B, the SDA signal comes from the external SMB socket, SDA input.
K1 to K4	Add a 51 Ω termination resistor to AGND at the V_{IN1} to V_{IN4} input sockets. When a 51 Ω termination is required, these links should be inserted.
LK9	Selects the source of the V_{DD} supply to the AD7993/AD7994. In Position A, the supply voltage, V_{DD} , is taken from the evaluation board controller via the 96-way connector. In Position B, the supply voltage, V_{DD} , is taken from an external source via J2.
LK10	Selects the source of the REF_{IN} voltage to be applied to the REF_{IN} pin of the AD7993/AD7994. In Position A, the AD780 supplies the 2.5 V reference to the AD7993/AD7994. In Position B, the REF192 supplies the 2.5 V reference to the AD7993/AD7994. In Position C, the reference is taken from the externally applied reference via the REF_{IN} SMB socket.
LK11	Controls the program pin of the AD780 voltage reference. When inserted, the AD780 output voltage is set to 3.0 V; when removed, the AD780 voltage is set to 2.5 V.
LK12	This link option selects the source of the \overline{CONVST} input signal for the AD7993/AD7994. In Position A, the \overline{CONVST} signal is taken from the evaluation controller board via the 96-way connector. In Position B, the \overline{CONVST} signal is taken from the externally applied \overline{CONVST} signal via the SMB socket.
LK13	Selects the voltage being applied to the AS pin that is used to set the final three bits of the AD7993/AD7994 I ² C bus address. In Position A, the AS pin is tied to VDD. In Position B, the AS pin is tied to AGND. Refer to the AD7993/AD7994 data sheet for the I ² C address for each configuration.
LK14	Adds a 51 Ω termination resistor to AGND at the input socket for V_{IN1} to V_{IN4} . When a 51 Ω termination is required, this link should be inserted.
LK15	Selects the source of the +12 V supply for the EVAL-AD7993/AD7994CB. In Position A, the +12 V supply is sourced from the evaluation board controller via the 96-way connector. In Position B, the +12 V supply is sourced externally via the J3 connector.
LK16	Selects the source of the -12 V supply for the EVAL-AD7993/AD7994CB. In Position A, the -12 V supply is sourced from the evaluation board controller via the 96-way connector. In Position B, the -12 V supply is sourced externally via the J3 connector.
LK17	Selects the source of the SCL clock to be fed into the 74HC05. In Position A, the SCL signal comes from the 96-way connector. In Position B, the SCL signal comes from the external SMB socket, SCL.
LK18	Selects the destination for the inverted SDA output from the AD7993/AD7994. In Position A, the inverted SDA signal is fed to the 96-way connector. In Position B, the inverted SDA signal is fed to the SDA output SMB socket.

EVAL-AD7993/AD7994CB

INITIAL SETUP CONDITIONS

ANALOG INPUT RANGES

Because the device is unipolar, the analog input range to the AD7993/AD7994 is 0 to REF_{IN} . Therefore, all bipolar signals need to be level shifted before being applied to the AD7993/AD7994. Each EVAL-AD7993/AD7994CB includes a bias-up circuit, which uses the reference voltage to bias up the bipolar analog input signal.

DEFAULT LINK POSITIONS

Before applying power and signals to the evaluation board, ensure that all link options are configured per the required operating mode. Table 2 outlines the positions of all links when packaged. EVAL-AD7993/AD7994CB are set for standalone capability only.

Table 2.

Link No.	Position	Function
LK1	A	Noninverting input of AD713 is connected to V_{IN1} SMB socket.
LK2 to LK4	B	Noninverting AD713 inputs are connected to AGND.
LK5	A	The SCL pin on the AD7993/AD7994 is connected to the SMB SCL socket.
LK6	A	The SDA pin on the AD7993/AD7994 is connected to the SMB SDA socket.
LK7	A	The BUSY/ALERT pin on the AD7993/AD7994 is connected to the SMB ALERT socket.
LK8	A	The SDA signal to be applied to the input of the 74HC05 inverter is applied through the SMB SDA input/output socket.
LK9	B	V_{DD} supply is taken from the J2 connector.
LK10	A	The AD780 supplies the reference voltage to the REF_{IN} pin on the AD7993/AD7994.
LK11	OUT	The $\overline{AD780}$ voltage reference is set to 2.5 V.
LK12	B	The \overline{CONVST} signal is taken from the \overline{CONVST} SMB socket. This is an externally generated signal.
LK13	A	The AS pin on the AD7993/AD7994 is tied to V_{DD} . See the AD7993/AD7994 data sheet for I ² C address options.
LK14	OUT	No 51 Ω resistance on the inputs.
LK15	B	The +12 V supply is applied through the J3 connector. This supply is used as the positive supply for the AD713 device.
LK16	B	The -12 V supply is applied through the J3 connector. This supply is used as the negative supply for the AD713 device.
LK17	B	The SCL signal to be applied to the 74HC05 inverter is applied to the SCL SMB socket.
LK18	B	An inverted SDA output signal is available at the SDA input/output SMB socket.
K1 to K4	OUT	No 51 Ω termination on the V_{IN1} to V_{IN4} analog inputs SMB sockets.

EVALUATION BOARD INTERFACING

Figure 2 shows the pinout for the 96-way J1 connector. Table 3 and Table 4 list the pin designations and descriptions.

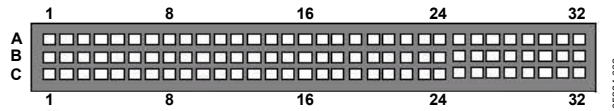

Figure 2. Pin Configuration for the 96-Way Connector J1

Table 3. Pin Designations (unused pins omitted for clarity)

Pin No.	Row A	Row B	Row C
1	FO	FL1	FI
2			
3			
4	DGND	DGND	DGND
5			
6			
7			
8			
9			
10			
11			
12	DGND	DGND	DGND
13			
14			
15			
16	DGND	DGND	DGND
17	FL0		IRQ2
18			
19			
20	DGND	DGND	DGND
21	AGND	AGND	AGND
22	AGND	AGND	AGND
23	AGND	AGND	AGND
24	AGND	AGND	AGND
25	AGND	AGND	AGND
26	AGND	AGND	AGND
27		AGND	
28		AGND	
29		AGND	
30	-12V	AGND	+12V
31			
32	AVDD	AVDD	AVDD

Table 4. Pin Descriptions

Pin	Description
FO	Flag Output. This pin is used to transmit data from the processor to the SDA pin of the AD7993/AD7994.
FL1	Flag Output 1. This pin is used to generate the $\overline{\text{CONVST}}$ pulse to initiate a conversion.
FI	Flag Input. This pin is used to transmit data into the processor from the SDA pin on the AD7993/AD7994.
FL0	Flag Output 0. This pin is used to provide the SCL signal to the AD7993/AD7994 from the processor.
IRQ2	Interrupt Receive. This pin is used to provide an ALERT/BUSY signal from the AD7993/AD7994 to the processor.
AGND	Analog Ground. This pin is connected to the analog ground plane of the EVAL-AD7993CB/AD7994CB.
AVDD	Analog 3 V/5 V Supply. This pin is used to supply the 3 V/5 V supply to the AD7993/AD7994 via LK9.
-12V	-12 V Supply. This pin is used to supply the -12 V power supply voltage to the EVAL-AD7993CB/AD7994CB.
+12V	+12 V Supply. This pin is used to supply the +12 V power supply voltage to the EVAL-AD7993CB/AD7994CB.

EVAL-AD7993/AD7994CB

SOCKETS

There are 17 input/output sockets for operating and configuring the EVAL-AD7993/AD7994CB. Table 5 describes the function of the sockets.

Table 5.

Pin	Description
J1	96-way connector for I ² C interface, power supply voltage, and AGND connections.
J2	External V _{DD} and AGND power connector.
J3	External +12 V, -12 V, and AGND power supply connector.
V _{IN}	SMB socket for bipolar analog input signal. This is the input to the bias-up circuit.
VBIASED	SMB socket for output from bias-up circuit. The voltage at this socket is a unipolar signal.
V _{IN1} to V _{IN4}	Four SMB sockets for analog inputs V _{IN1} to V _{IN4} of the AD7993/AD7994.
REF _{IN}	SMB socket for the REF _{IN} voltage to the AD7993/AD7994.
$\overline{\text{SCL}}$	SMB socket for an inverted SCL input signal. The signal applied to this socket is applied to the input of the 74HC05 inverter.
SCL	SMB socket for the SCL input signal to the SCL pin of the AD7993/AD7994.
$\overline{\text{CONVST}}$	SMB socket for an externally applied $\overline{\text{CONVST}}$ input signal.
SDA_I/P	SMB socket for external SDA input signal
SDA_O/P	SMB socket for SDA output signal from the SDA pin on the AD7993/AD7994. The data available at this socket is inverted after being clocked out of the AD7993/AD7994.
SDA	SMB socket for SDA data to/from the AD7993/AD7994.
ALERT/BUSY	SMB socket for ALERT/BUSY output from the AD7993/AD7994.

SCHEMATICS

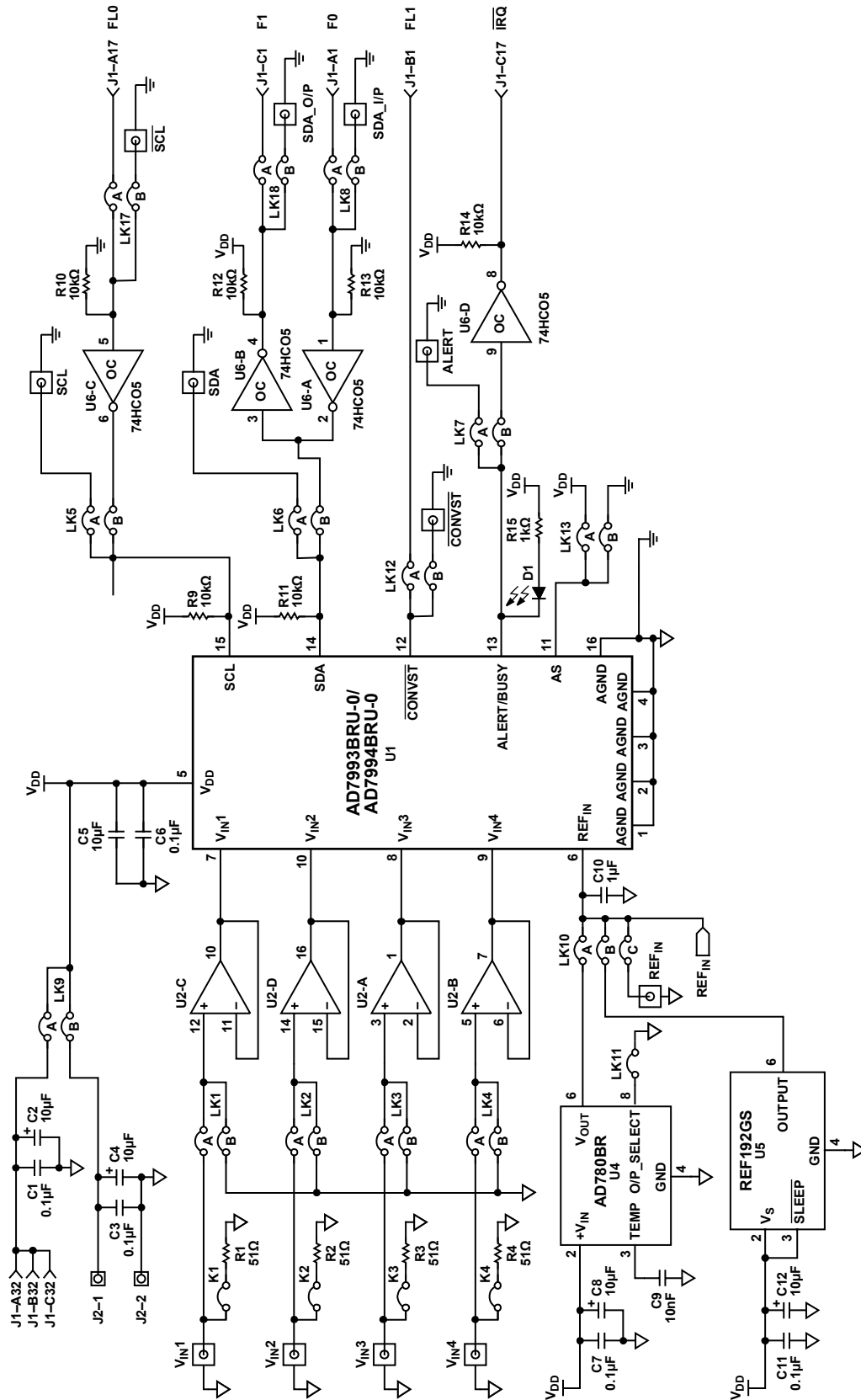

Figure 3. EVAL-AD7993/AD7994CB Schematic

EVAL-AD7993/AD7994CB

U3-A (NOT USED)

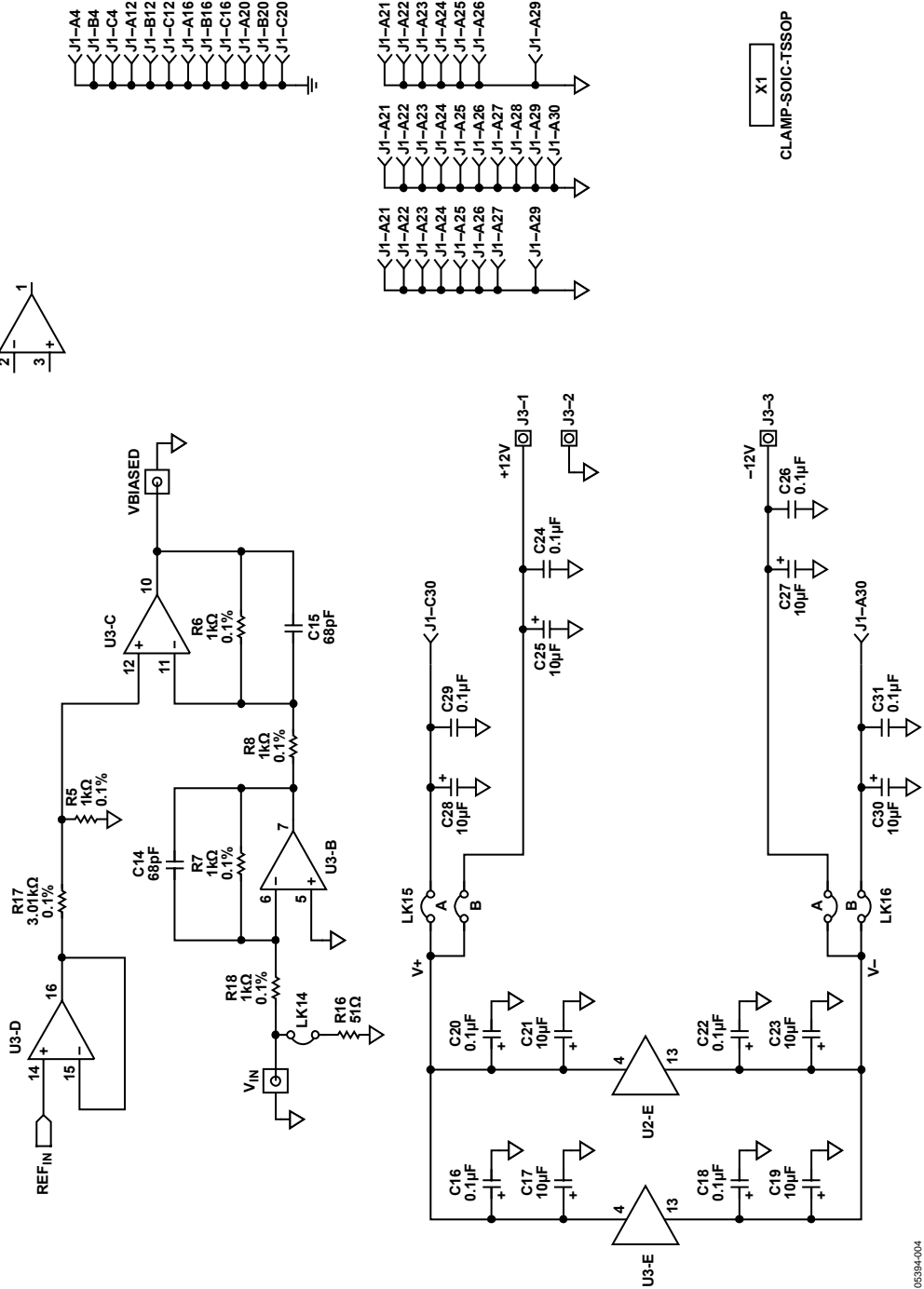
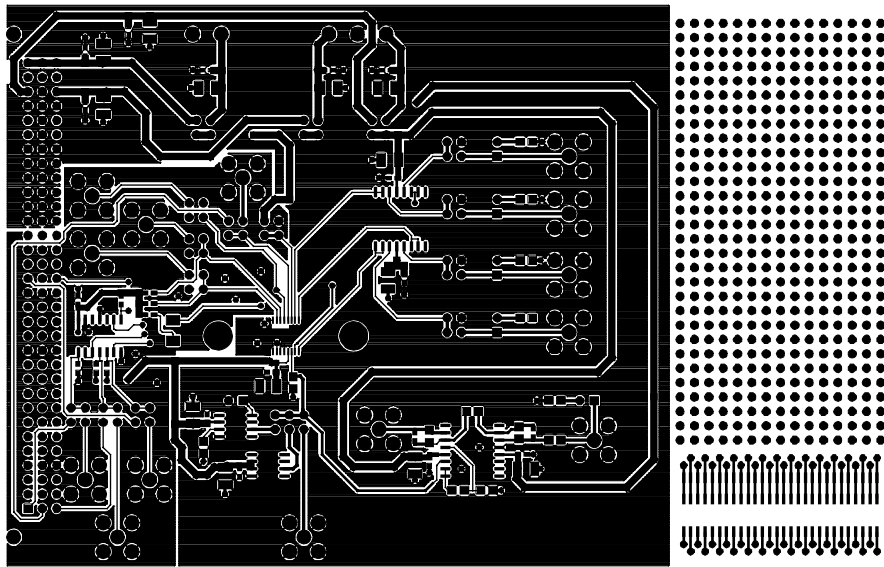

Figure 4. EVAL-AD7993/AD7994CB Schematic

05394-004



Eval-AD7993/94CB Rev. A [Component Side View] Component Side

05394-006

Figure 5. Top Side Layer (Not to Scale)

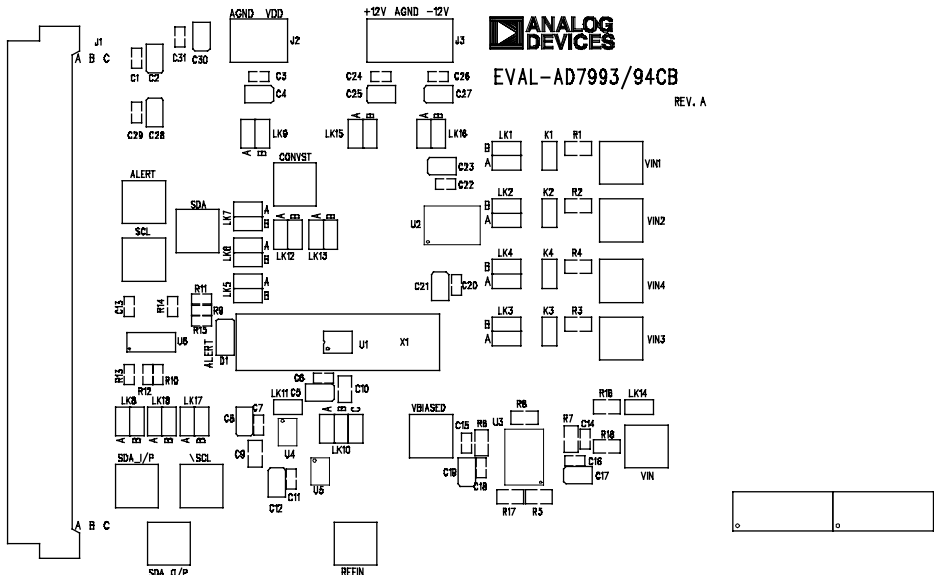

Eval-AD7993/94CB Rev. A [Component Side View]

Silkscreen

05394-005

Figure 6. Top Side Silkscreen (Not to Scale)

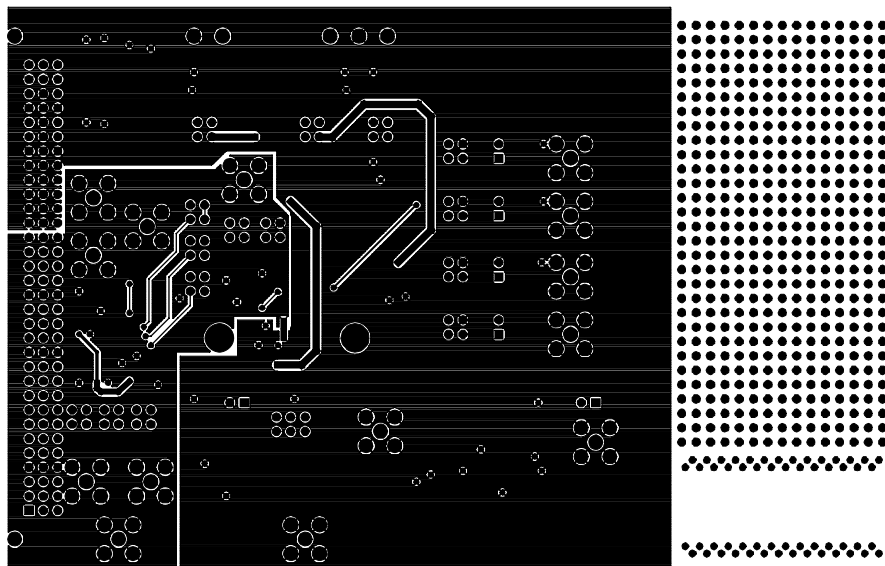

Eval-AD7993/94CB Rev. A (Component Side View)

Solder Side

05394-007

Figure 7. Bottom Side Layer (Not to Scale)

ORDERING INFORMATION

BILL OF MATERIALS

Table 6.

Name ¹	Value	Part Description	Stock Code
C1, C3, C6, C7, C11, C13, C16, C18, C20, C22, C24, C26, C29, C31	0.1 μ F	Multilayer ceramic capacitor	FEC ² 432-210
C2, C4, C5, C8, C12, C17, C19, C21, C23, C25, C27, C28, C30	10 μ F	16 V SMD tantalum capacitor	FEC 498-737
C9	10 nF	Multilayer ceramic capacitor	FEC 499-225
C10	1 μ F	Multilayer ceramic capacitor	FEC 317-640
C14, C15	68 pF	Multilayer ceramic capacitor	FEC 722-066
(REF _{IN} , SCL, SDA_O/P, SDA_I/P, SDA, SCL, ALERT, VBIASED, V _{IN} , V _{IN1} to V _{IN4} , CONVST) ¹		Gold SMB 50 Ω jack	FEC 310-682
D1		Red SMD LED	FEC 515-607
J1		96-pin DIN41612 90° connector	FEC 225-393
J2		2-pin terminal block	FEC 151-785
J3		3-pin terminal block	FEC 151-786
K1 to K4, LK11, LK14		2-pin header (2 \times 1)	FEC 511-780 and FEC 150-410
LK1 to LK9, LK12, LK13, LK15 to LK18		4-pin header (2 \times 2)	FEC 511-705 and FEC 150-410
LK10		6-pin header (2 \times 3)	FEC 511-780 and FEC 150-410
R1 to R4, R16	51 Ω	0.1 W SMD resistor	FEC 321-7905
R5 to R8, R15, R18	1 k Ω	0.1 W SMD precision resistor	FEC 554-005
R9 to R14	10 k Ω	0.1 W SMD resistor	FEC 911-355
R17	3.01 k Ω	0.1 W SMD precision resistor	FEC 554-467
U1		10-/12-bit ADCs	AD7993BRU-0/AD7994BRU-0
U2, U3		Quad op amp	AD713JR-16
U4		2.5 V/3 V reference	AD780BR
U5		Voltage reference	REF192GS
U6		Hexadecimal inverter with open drain	Digi-Key Corporation 296-1190-1-ND
X1		Clamp-SOIC-TSSOP	Analog Devices, Inc., supplied

¹ These names are as they appear on the silkscreen of the board.

² FEC prefix is for Farnell part numbers.

EVAL-AD7993/AD7994CB

ORDERING GUIDE

Model	Description
EVAL-AD7993CB	Evaluation Board for AD7993
EVAL-AD7994CB	Evaluation Board for AD7994