

GENERAL DESCRIPTION

This data sheet describes the evaluation board for the [ADT7473](#), which is a thermal monitor and multiple PWM fan controller. The ADT7473 evaluation board allows all the input and output functions of the ADT7473 to be demonstrated. The software

allows control and monitoring of the ADT7473 internal registers. By using the evaluation board with its software, the ADT7473 can be interfaced to any personal computer running Windows® XP or Windows 2000 via the USB port.

FUNCTIONAL BLOCK DIAGRAM

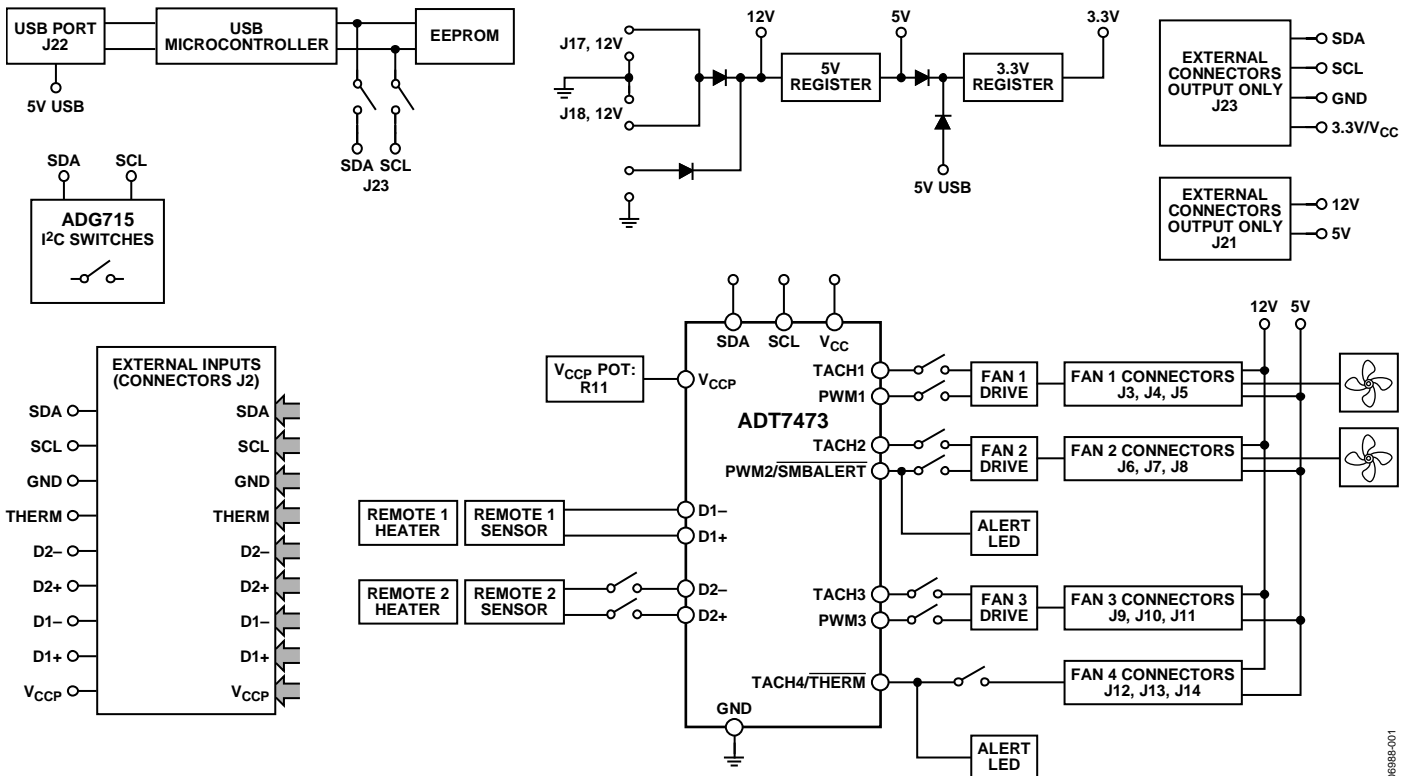

Figure 1.

Rev. 0

Evaluation boards are only intended for device evaluation and not for production purposes. Evaluation boards are supplied "as is" and without warranties of any kind, express, implied, or statutory including, but not limited to, any implied warranty of merchantability or fitness for a particular purpose. No license is granted by implication or otherwise under any patents or other intellectual property by application or use of evaluation boards. Information furnished by Analog Devices is believed to be accurate and reliable. However, no responsibility is assumed by Analog Devices for its use, nor for any infringements of patents or other rights of third parties that may result from its use. Analog Devices reserves the right to change devices or specifications at any time without notice. Trademarks and registered trademarks are the property of their respective owners. Evaluation boards are not authorized to be used in life support devices or systems.

TABLE OF CONTENTS

General Description	1	Evaluation Board Configuration	6
Functional Block Diagram	1	Automatic Fan Control.....	7
Revision History	2	Dynamic T _{MIN} Control.....	7
Evaluation Board Hardware.....	3	Evaluation Board Schematics.....	8
Evaluation Board Software	4	Ordering Information.....	13
Quick Guide to Setting Up and Using the ADT7473		Bill of Materials.....	13
Evaluation Kit	4	Ordering Guide	14
Graphing Window.....	5	ESD Caution.....	14

REVISION HISTORY

9/07—Revision 0: Initial Version

EVALUATION BOARD HARDWARE

The evaluation kit contains the following:

- One ADT7473 device
- Two remote transistors for temperature sensing
- Two 5 V fans and fan drive circuitry
- 12 V fan connectors
- Electronic configuration switches
- Indicator LEDs
- On-board heaters (allow demonstration of fan response over temperature)
- USB interface circuitry
- External 12 V power connectors (required for fans and heaters; the ADT7473 device is powered from the USB port)
- Potentiometer for voltage adjustment
- Push button for THERM assertion

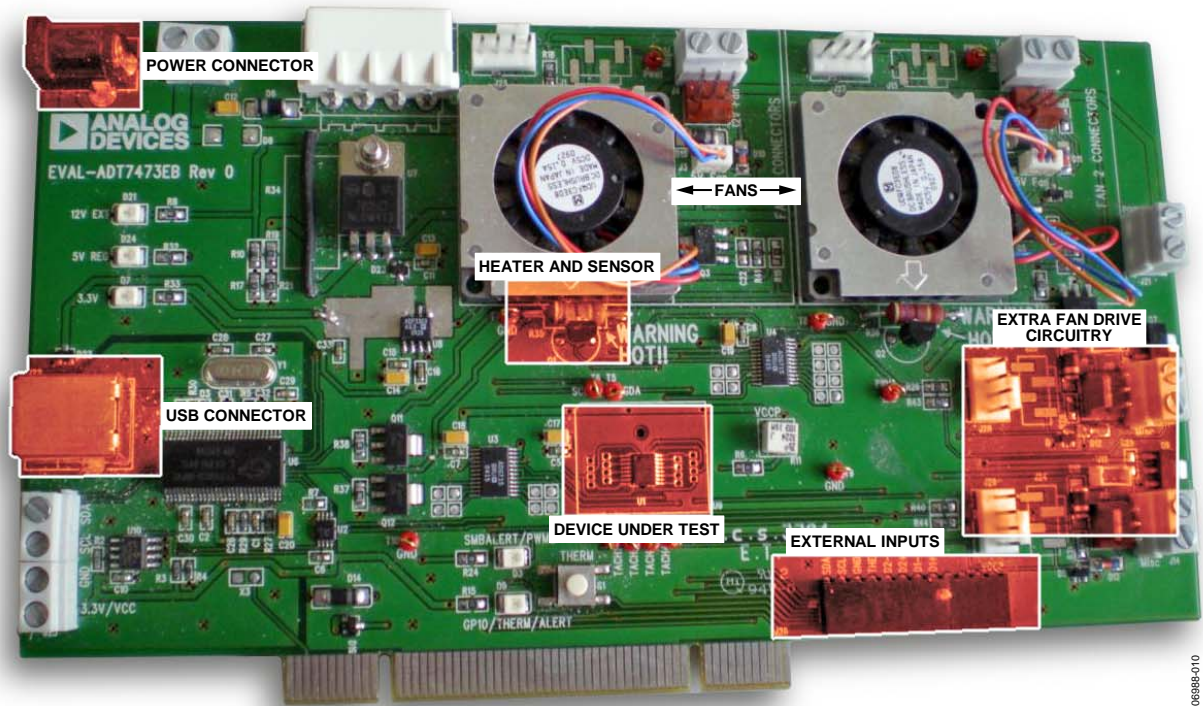

Figure 2. Digital Picture of Board

EVALUATION BOARD SOFTWARE

QUICK GUIDE TO SETTING UP AND USING THE ADT7473 EVALUATION KIT

It is important to install the software before connecting the ADT7473 evaluation board to the USB port. Software is available on the enclosed CD. The ADT7473 evaluation board can be powered from the USB port. A separate 12 V power supply is required to run the fans.

To open the ADT74XX software, follow these steps:

1. Click the **Start** button, located at the bottom left-hand corner of your desktop.
2. You can find this software file on C:\Programs Files\Analog Devices\ADT74XX EvaluationSoftware. Click the **ADT74xx Eval Software.exe** to load the software.
3. The ADT74XX software, once started, looks for the device it is about to communicate with. The following dialog boxes appear (see Figure 3, Figure 4, and Figure 5).

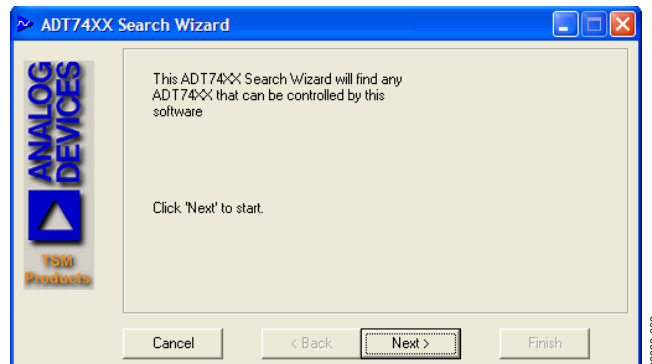

Figure 3. Finding the Device

Click the **Next >** button.

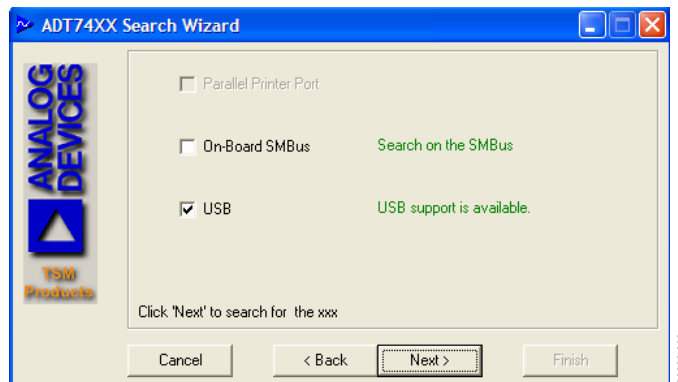

Figure 4. USB Search for ADT74XX Devices

Select the **USB** check box, then click the **Next >** button. This searches the USB for any ADT74XX devices.

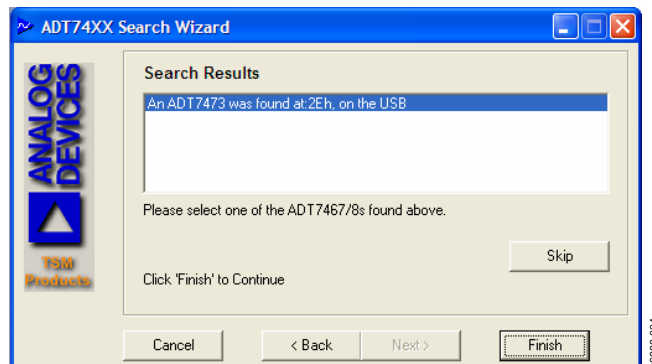

Figure 5. Search Results

Select the ADT7473 device from the **Search Results** list box and click **Finish**.

GRAPHING WINDOW

Once the software is loaded, it starts up. To open the graphing window, click **Visual Display** from the **Main** drop-down menu.

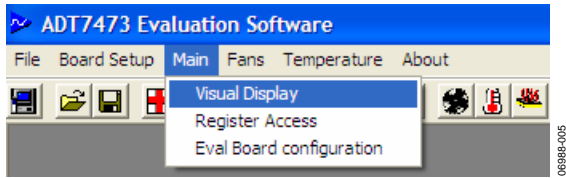

Figure 6. Opening the Visual Display Graphing Window

The graphing window displays the temperature of the local and remote sensors, the fan RPM, and the PWM % duty cycle for each of the PWM channels. It also displays the different voltage readings taken from the board.

Limits for **Local**, **Remote 1**, **Remote 2**, **Fan 1**, **Fan 2**, **Fan 3**, **Fan 4**, **Vccp**, and **Vcc** channels can be adjusted using the sliders in the graph. The upper limit (red) and lower limit (blue) are adjusted by clicking and dragging the slider up or down. The status changes from green to red on an out-of-limit event for the corresponding channel.

The on-board potentiometer can be used to adjust the V_{CCP} voltage.

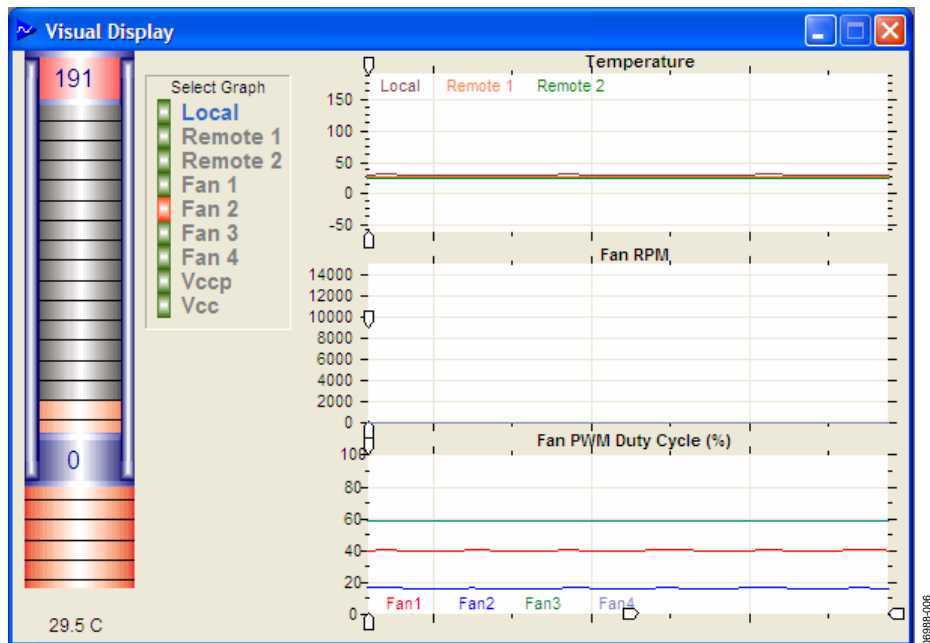

Figure 7. Visual Display Graphing Window

EVAL-ADT7473

EVALUATION BOARD CONFIGURATION

Some pins on the ADT7473 share functionality (Pin 5, Pin 9, and Pin 15). To change the function of these pins, open the **Eval board configuration** window (see Figure 9) by clicking **Eval Board configuration** from **Main** on the drop-down menu toolbar.

The on-board heaters can be turned on and off in the **Eval board configuration** window by clicking the appropriate heater (Q1 or Q2). In Figure 8, Heater Q1 is turned on.

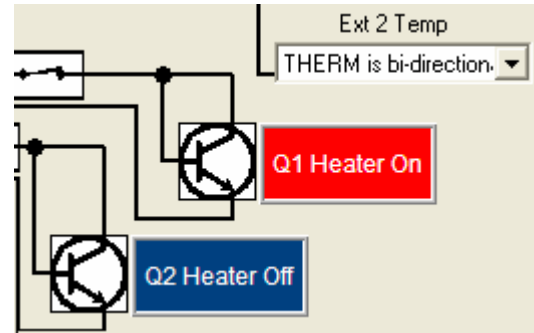

Figure 8. On-Board Heater Control

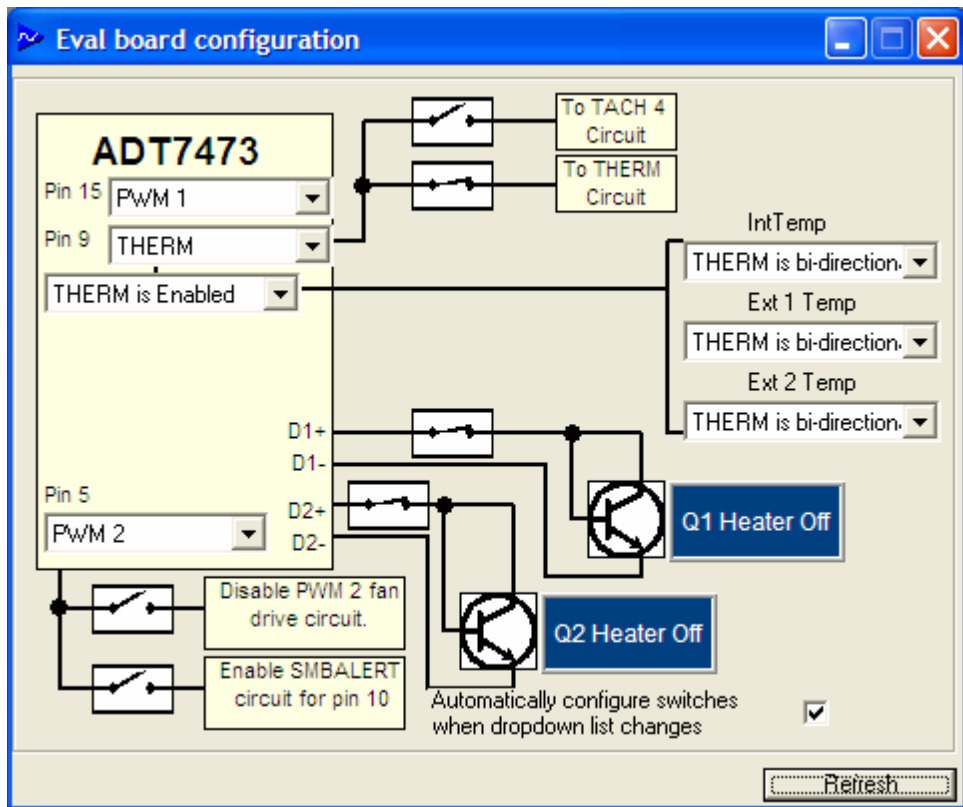

Figure 9. Evaluation Board Configuration Window

AUTOMATIC FAN CONTROL

Automatic fan control can be configured by opening the automatic fan control window. To open this window, click **Basic AFC** on the **Fans** drop-down menu toolbar. The fans can be configured to be controlled by any temperature, and the associated settings (T_{MIN} , T_{RANGE} , PWM_{MIN} , and PWM_{MAX}) can be changed in this window. In Figure 10, the settings for PWM1 are shown.

Note that the sliders should be dragged to the right to increase the value and to the left to decrease the value.

- **Max PWM** changes the maximum speed that the fan can run at while the temperature reading is below the THERM limit.
- **Min PWM** changes the minimum speed that the fan can run at while the temperature reading is above the T_{MIN} limit.
- **TMIN** indicates the temperature at which the fan turns on. At this temperature, the fans run at the value of **Min PWM** duty cycle.
- **T THERM** is the temperature at which the fan goes to full speed (most likely a critical temperature).
- **Temp Hyst** is the range below which the temperature reading must reduce before the fan decreases its speed.
- **TRange** defines the slope of the line from **Min PWM** duty cycle to **Max PWM** duty cycle.

- **Operating Point** is a temperature that the user wishes to maintain. This is used in an algorithm to dynamically adjust the fan speed.
- **Min Temp Limit**—If the temperature reading drops below this limit, an error flag is set in the status register and an SMBALERT interrupt is generated.
- **Max Temp Limit**—If the temperature reading exceeds this limit, an error flag is set in the status register and an SMBALERT interrupt is generated.

DYNAMIC T_{MIN} CONTROL

Dynamic T_{MIN} control allows the ADT7473 to intelligently adapt the system's cooling solution for best system performance or lowest possible system acoustics, depending on user or design requirements. The ADT7473 can self-adjust its fan control loop to maintain either an operating temperature or a system target temperature. For example, it can be specified that the ambient temperature in a system be maintained at 50°C. If the temperature is below 50°C, then fans may not need to run or may run very slowly. If the temperature is higher than 50°C, the fans need to throttle up.

The dynamic T_{MIN} control settings can be adjusted in the automatic fan control window (see Figure 10). The **Enable Dynamic tmin** checkbox must be selected in order for this function to work.

For more information on the [ADT7473](#), see the device data sheet.

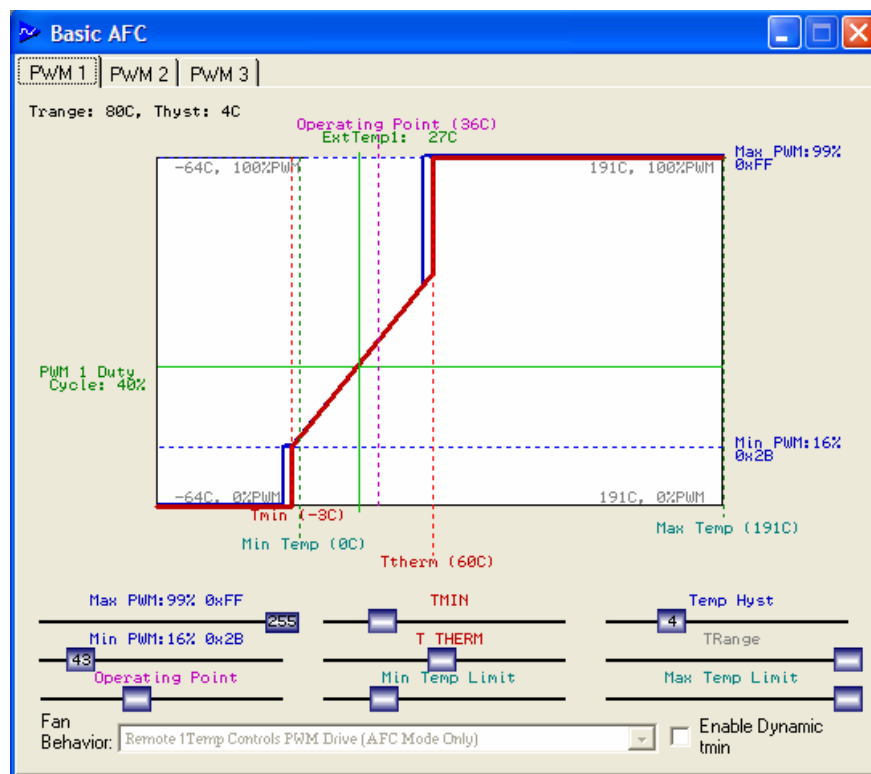

Figure 10. Automatic Fan Control Window

EVALUATION BOARD SCHEMATICS

110-89690

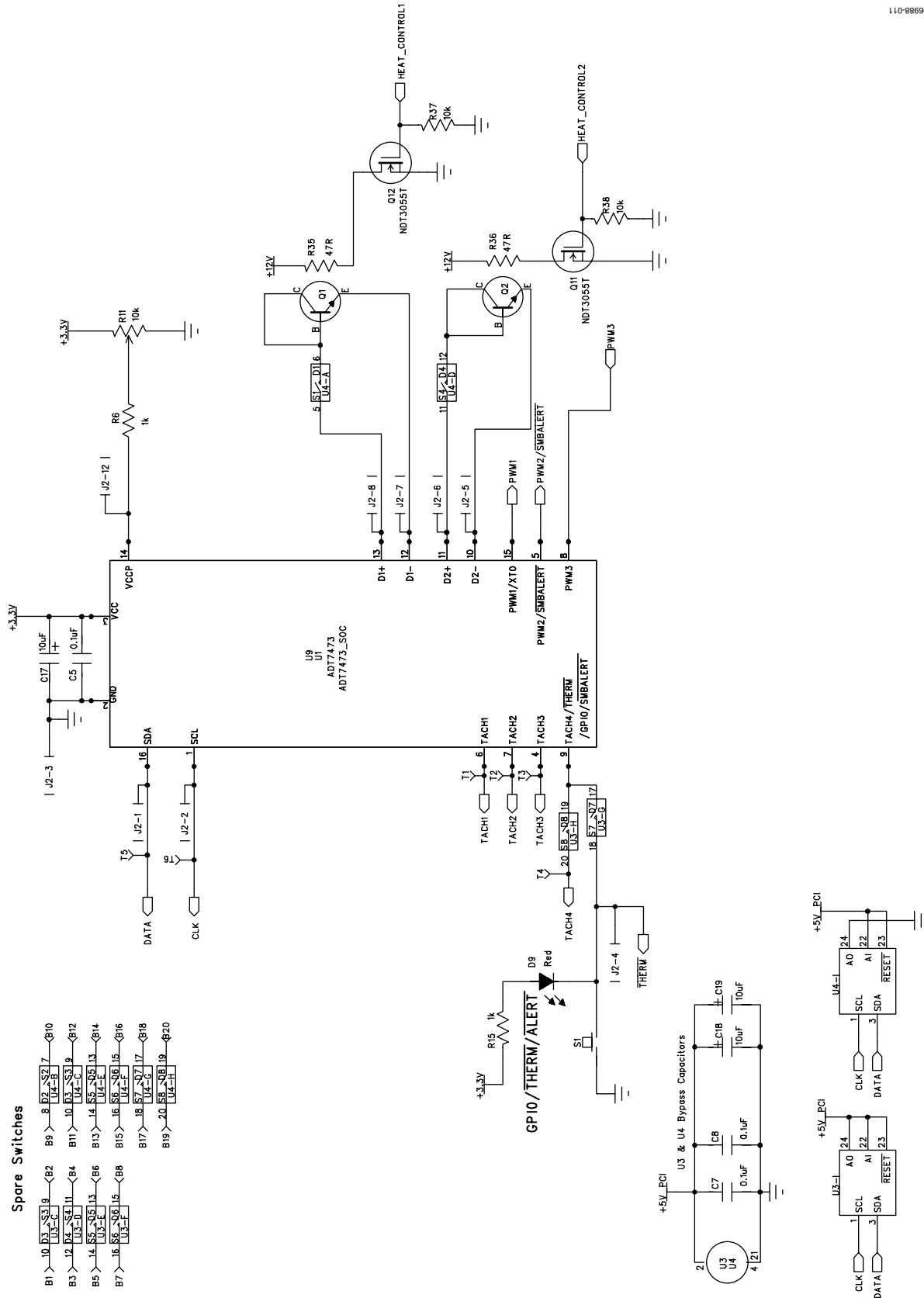
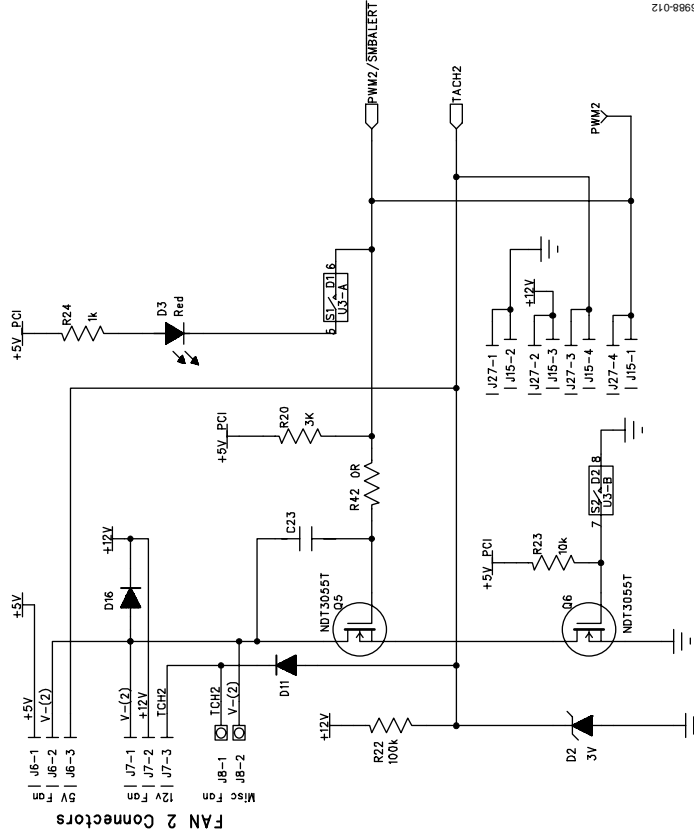

Figure 11. EVAL-ADT7473 Schematics, Page 1

06988-012

FAN 2 Drive Circuitry



FAN 2 Connectors

FAN 1 Drive Circuitry

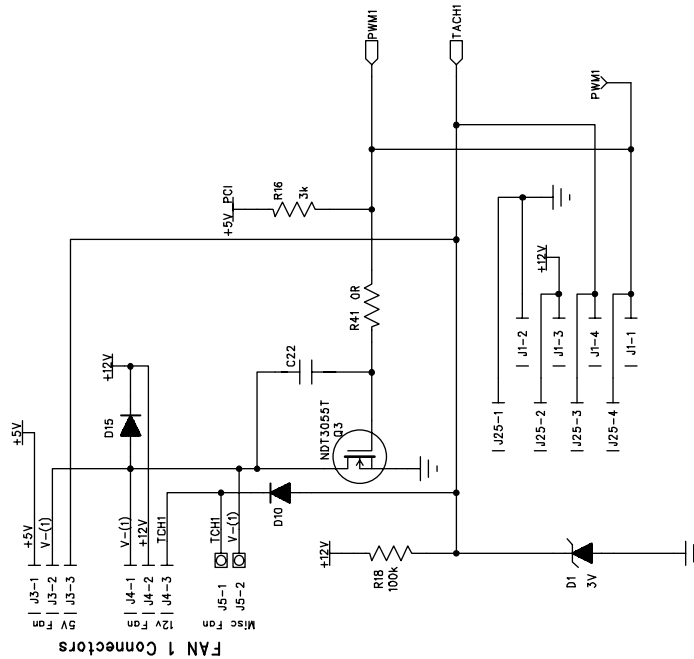

FAN 1 Connectors

Figure 12. EVAL-ADT7473 Schematics, Page 2

FAN 4 Drive Circuitry

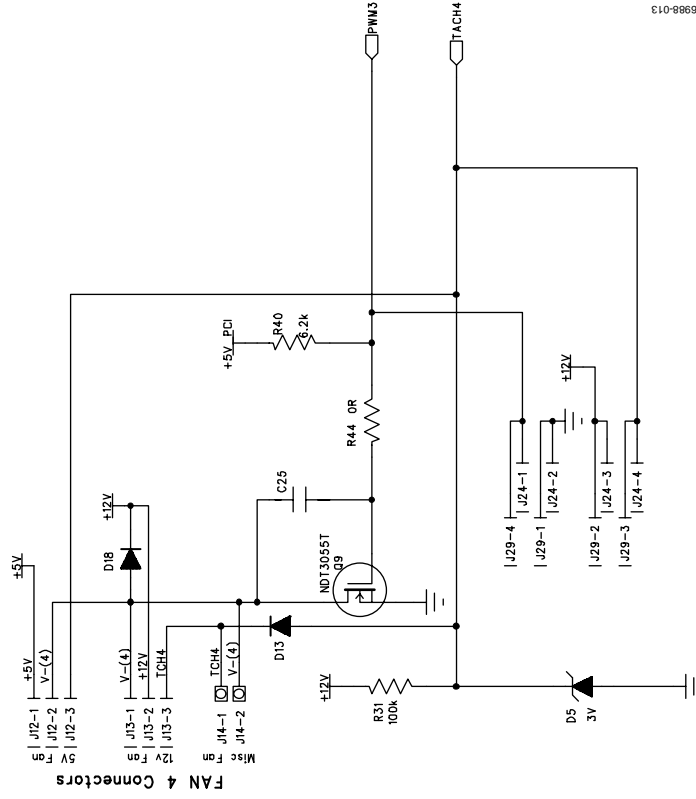

FAN 3 Drive Circuitry

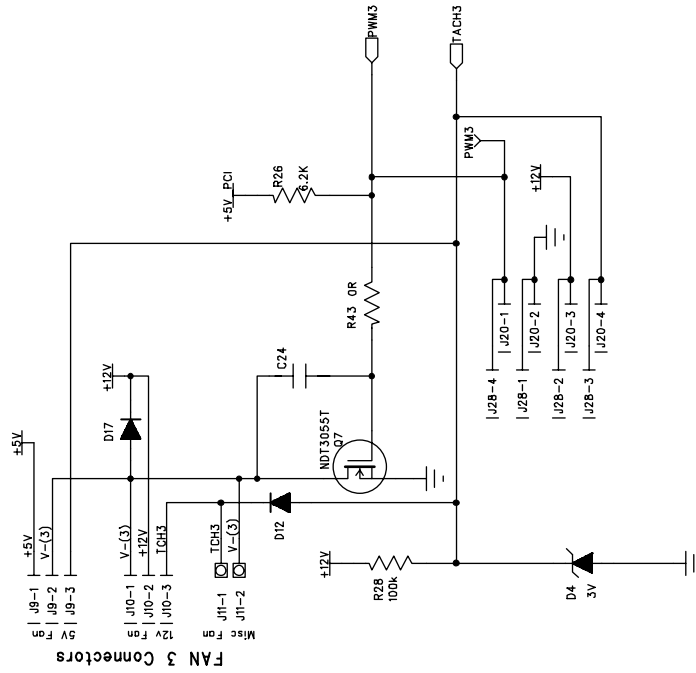

Figure 13. EVAL-ADT7473 Schematics, Page 3

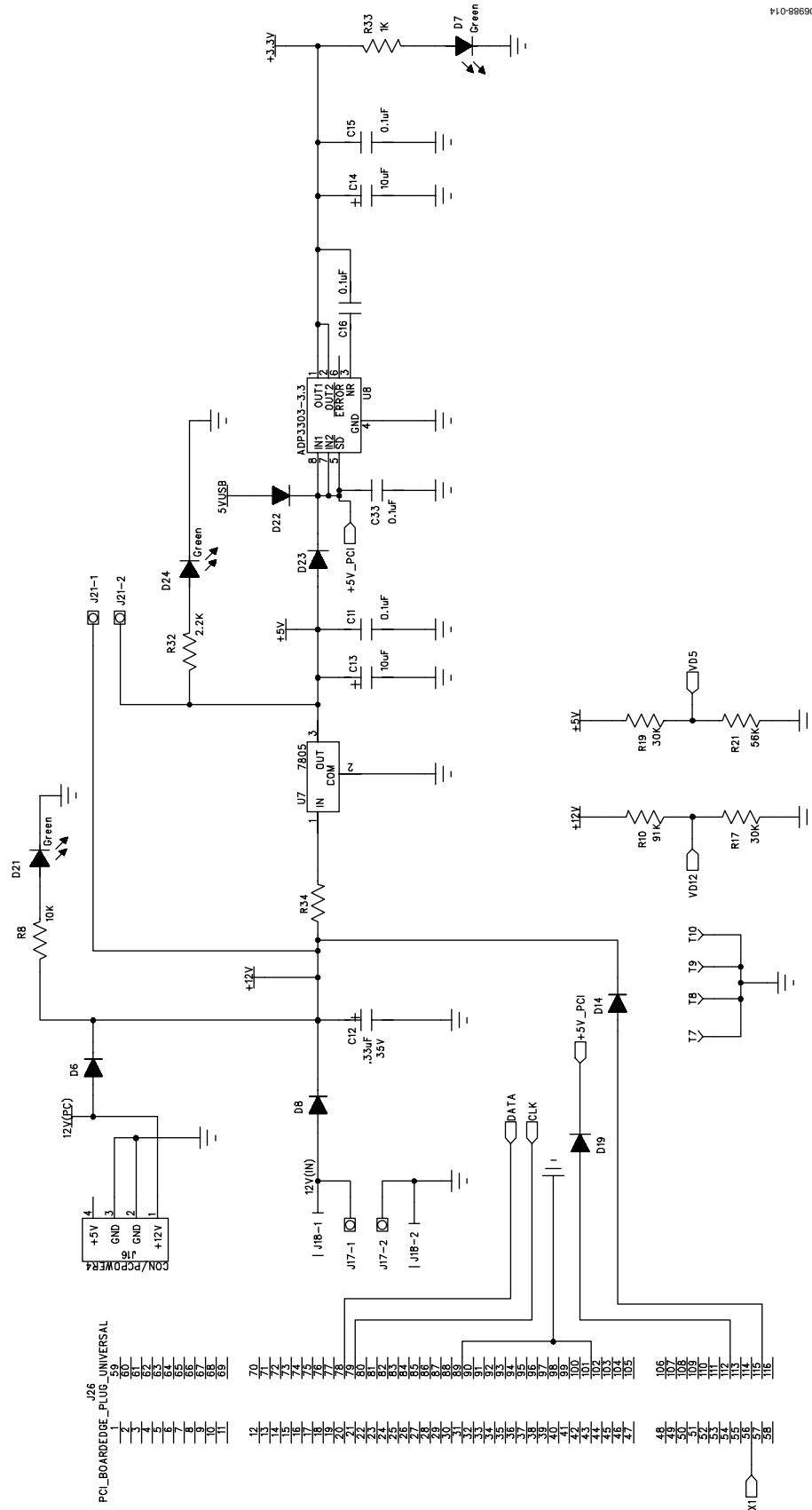

Figure 14. EVAL-ADT7473 Schematics, Page 4

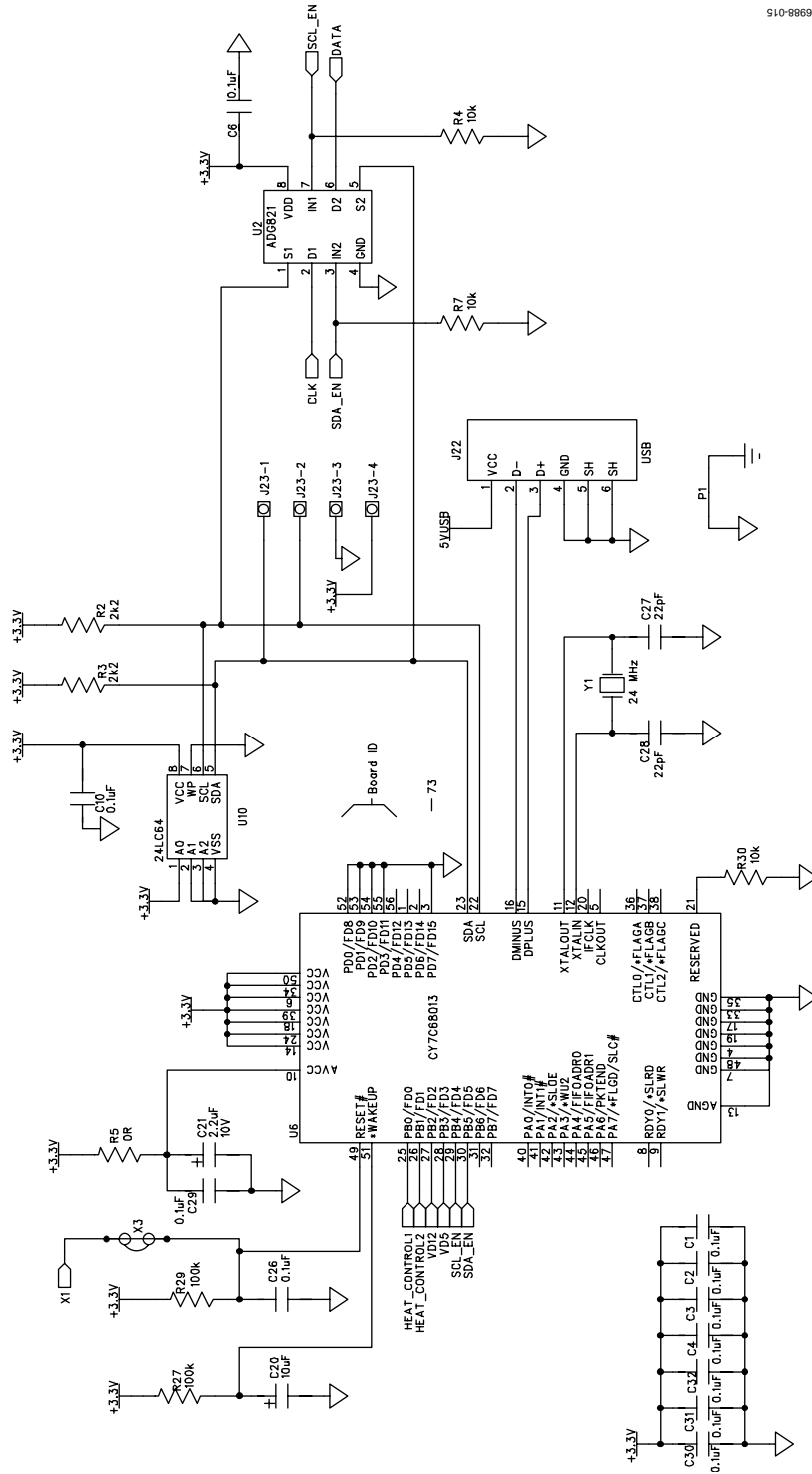

Figure 15. EVAL-ADT7473 Schematics, Page 5

ORDERING INFORMATION

BILL OF MATERIALS

Table 1.

Qty.	Designator	Description	Supplier/Part No. ¹
18	C1 to C8, C10, C11, C15, C16, C26, C29 to C33	Capacitor, 0603, 0.1 μ F, 25 V	FEC 9406204
1	C12	Capacitor, Case A, 0.33 μ F, 35 V	FEC 498919
6	C13, C14, C17 to C20	Capacitor, Case A, 10 μ F, 10 V	FEC 9751041
1	C21	Capacitor, Case A, 2.2 μ F, 10 V	FEC 9753796
4	C22 to C25	Multilayer ceramic capacitor (0805 case)	Not Inserted
2	C27, C28	Capacitor, 0603, 22 pF, 50 V, NPO	FEC 9406107
4	D1, D2, D4, D5	Diode, Zener 250 mW, 3.3 V (clamped at 3 V)	FEC 1081419
2	D3, D9	LED, SMD, super bright red	FEC 1212753
7	D6, D8, D14 to D18	Rectifier diode, passivated, 1 A, 50 V, SMD MELF	Digi-Key DL4001-TPMSCT-ND
3	D7, D21, D24	LED, green, SMD, PLCC-2	FEC 1058390
4	D10 to D13	Diode, Schottky	FEC 9804234
3	D19, D22, D23	Diode, Schottky SOT-23	FEC 9526765
2	Fan 1, Fan 2	Fan, 5 V, dc, 145 mA, 34.5 mm, MPU flat	Digi-Key P9697-ND
4	J1, J15, J20, J24	Connector header, 0.100-inch center vertical, 4-position SMD	Digi-Key WM7204-ND
2	J2	Socket, 0.1 inch, PCB, 6-way	FEC 7992084
4	J3, J6, J9, J12	Connector header, 3-position, 1.25 mm, vertical, tin	FEC 9732853
4	J4, J7, J10, J13	Connector header, 3-position, 0.100 vertical, tin	FEC 5223740
6	J5, J8, J11, J14, J17, J21	Terminal block, PCB 2-way (5 mm)	FEC 9632972
1	J16	Connector header pin, right angle, 4-position, tin	FEC 7854510
1	J18	Socket, PCB, dc power, 2.1 mm	FEC 224959
1	J22	Socket, USB-B, single	FEC 1097897
1	J23	Terminal block, PCB 4-way (5 mm)	FEC 9632697
4	J25, J27 to J29	Generic 4-pin, SIP header, 0.100 centers	Molex 47053-1000
3	PWM1 to PWM3	Terminal, PCB, red	FEC 8731144
2	Q1, Q2	General-purpose NPN silicon transistor	FEC 9558420
7	Q3, Q5 to Q7, Q9, Q11, Q12	MOSFET, N SOT-223	FEC 9845305
2	R2, R3	Resistor, 0603, 2.2 k Ω	FEC 9330810
3	R4, R7, R30	Resistor, 0603, 10 k Ω	FEC 9330399
1	R5	Resistor, 0603, 0 Ω	FEC 9331662
2	R6, R15	Resistor, 0805, 1 k Ω	FEC 9332383
4	R8, R23, R37, R38	Resistor, 0805, 10 k Ω	FEC 9332391
1	R10	Resistor, 0805, 91 k Ω	FEC 9333649
1	R11	Trimmer, SMD, 5-turn, 10 k Ω	FEC 988273
2	R16, R20	Resistor, 0805, 3 k Ω	FEC 9332995
2	R17, R19	Resistor, 0805, 30 k Ω	FEC 9333002
4	R18, R22, R28, R31	Resistor, 0805, 100 k Ω	FEC 9332405
1	R21	Resistor, 0805, 56 k Ω	FEC 9333380
2	R24, R33	Resistor, 0805, 1 k Ω	FEC 9332383
2	R26, R40	Resistor, 0805, 6.2 k Ω	FEC 9333428
2	R27, R29	Resistor, 0603, 100 k Ω	FEC 9330402
1	R32	Resistor, 0805, 2.2 k Ω	FEC 9332812
1	R34	Wire link	
2	R35, R36	Resistor, PRO2, 5%, 47 Ω , 2 W	FEC 9475346
4	R41 to R44	Resistor, 0805, 0 Ω	FEC 9333681
1	S1	SMD push-button switch (sealed 6 mm \times 6 mm)	FEC 177807
10	T1 to T10	Terminal, PCB, red	FEC 8731144
1	U1	System monitor and fan controller	Analog Devices ADT7473ARQZ

EVAL-ADT7473

Qty.	Designator	Description	Supplier/Part No. ¹
1	U2	Low voltage dual SPST switches	Analog Devices ADG821BRMZ
2	U3, U4	CMOS octal SPST switch	Analog Devices ADG715BRUZ
1	U6	IC MCU USB peripheral high speed 56SSOP	Digi-Key 428-1627-ND
1	U7	IC, regulator, 5.0 V	FEC 9666095
1	U8	Precision low dropout voltage regulator	Analog Devices ADP3303ARZ-3.3
1	U9	16-pin QSOP socket	Not Inserted
1	U10	IC, SM EEPROM serial 64 kbit	FEC 9758070
1	Y1	Crystal, 24.000000 MHZ	FEC 9509640

¹ FEC = Farnell Electronic Components.

ORDERING GUIDE

Model	Package Description
EVAL-ADT7473EBZ ¹	Evaluation Board

¹ Z = RoHS Compliant Part.

ESD CAUTION



ESD (electrostatic discharge) sensitive device. Charged devices and circuit boards can discharge without detection. Although this product features patented or proprietary protection circuitry, damage may occur on devices subjected to high energy ESD. Therefore, proper ESD precautions should be taken to avoid performance degradation or loss of functionality.

NOTES

EVAL-ADT7473

NOTES