

TYPES SN7406, SN7416, SN5406, SN5416
HEX INVERTER BUFFERS/DRIVERS WITH
OPEN-COLLECTOR HIGH-VOLTAGE OUTPUTS
 DECEMBER 1983 · REVISED MARCH 1988

- **Converts TTL Voltage Levels to MOS Levels**
- **High Sink-Current Capability**
- **Input Clamping Diodes Simplify System Design**
- **Open-Collector Driver for Indicator Lamps and Relays**
- **Inputs Fully Compatible with Most TTL Circuits**
- **Package Options Include Standard Plastic (N) and Ceramic (J) 300-mil Dual-In-Line Packages and Plastic Small Outline (D) Packages.**

SN5406, SN5416 . . . J PACKAGE
 SN7406, SN7416 . . . D OR N PACKAGE
 (TOP VIEW)

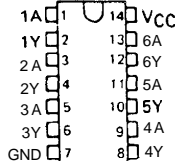

description

These monolithic TTL hex inverter buffers/drivers feature high-voltage open-collector outputs for interfacing with high-level circuits (such as MOS), or for driving high-current loads (such as lamps or relays), and are also characterized for use as inverter buffers for driving TTL inputs. The SN5406 and SN7406 have minimum breakdown voltages of 30 volts and the SN5416 and SN7416 have minimum breakdown voltages of 15 volts. The maximum sink current is 30 milliamperes for the SN5406 and SN5416, and 40 milliamperes for the SN7406 and SN7416.

logic symbol†

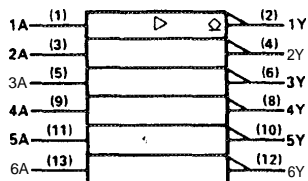

† This symbol is in accordance with ANSI/IEEE Std 91-1984 and IEC Publication 617-12.

schematic

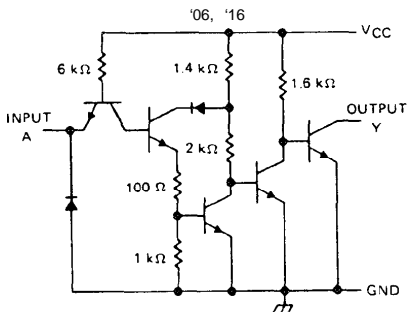

Resistor values shown are nominal.

logic diagram (positive logic)

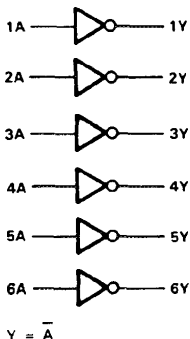

TYPES SN7406, SN7416, SN5406, SN5416

HEX INVERTER BUFFERS/DRIVERS WITH OPEN-COLLECTOR HIGH-VOLTAGE OUTPUTS

absolute maximum ratings over operating free-air temperature range (unless otherwise noted)

| | |
|---|----------------|
| Supply voltage, V_{CC} (see Note 1) | 7 v |
| Input voltage (see Note 1) | 5.5 v |
| Output voltage (see Notes 1 and 2): SN5406, SN7406 Circuits | 30 v |
| SN5416, SN7416 Circuits | 15 v |
| Operating free-air temperature range: SN5406, SN5416 Circuits | -55°C to 125°C |
| SN7406, SN7416 Circuits | 0°C to 70°C |
| Storage temperature range | -65°C to 150°C |

NOTES 1. Voltage values are with respect to network ground terminal.
This is the maximum voltage which should be applied to any output when it is in the off state.

recommended operating conditions

| | SN5406 SN5416 | | | SN7406 SN7416 | | | UNIT | | |
|--------------------------------------|------------------|-----|-----|------------------|-----|------|------|----|---|
| | MIN | NOM | MAX | MIN | NOM | MAX | | | |
| V_{CC} Supply voltage | 4.5 | 5 | 5.5 | 4.75 | 5 | 5.25 | V | | |
| V_{IH} High-level input voltage | 2 | | | 2 | | | V | | |
| V_{IL} Low-level input voltage | 0.8 | | | 0.8 | | | V | | |
| V_{OH} High-level output voltage | '06 | | | 30 | | | v | | |
| | '16 | | | 15 | | | | | |
| I_{OL} Low-level output current | 30 | | | 40 | | | mA | | |
| T_A Operating free-air temperature | -55 | | | 125 | | | 0 | 70 | c |

electrical characteristics over recommended operating free-air temperature range (unless otherwise noted)

| PARAMETER | TEST CONDITIONS† | SN5406 SN5416 | | SN7406 SN7416 | | UNIT | |
|-----------|--|--------------------------|------|------------------|-----|------|------|
| | | MIN | TYP‡ | MAX | MIN | | TYP‡ |
| V_{IK} | $V_{CC} = \text{MIN}$, $I_I = -12 \text{ mA}$ | -1.5 | | -1.5 | | V | |
| I_{OH} | $V_{CC} = \text{MIN}$, $V_{IL} = 0.8 \text{ V}$, $V_{OH} = \S$ | 0.25 | | 0.25 | | mA | |
| V_{OL} | $V_{CC} = \text{MIN}$, $V_{IH} = 2 \text{ V}$ | $I_{OL} = 16 \text{ mA}$ | | 0.4 | | V | |
| | | $I_{OL} = ¶$ | | 0.7 | | | |
| I_I | $V_{CC} = \text{MAX}$, $V_I = 5.5 \text{ V}$ | 1 | | 1 | | mA | |
| I_{IH} | $V_{CC} = \text{MAX}$, $V_{IH} = 2.4 \text{ V}$ | 40 | | 40 | | µA | |
| I_{IL} | $V_{CC} = \text{MAX}$, $V_{IL} = 0.4 \text{ V}$ | -1.6 | | -1.6 | | mA | |
| I_{CCH} | $V_{CC} = \text{MAX}$ | 30 | | 30 | | 48 | mA |
| I_{CCL} | $V_{CC} = \text{MAX}$ | 32 | | 32 | | 51 | mA |

† For conditions shown as MIN or MAX, use the appropriate value specified under recommended operating conditions.

‡ All typical values are at $V_{CC} = 5 \text{ V}$, $T_A = 25^\circ\text{C}$.

§ $V_{OH} = 30 \text{ V}$ for '06 and 15 V for '16.

¶ $I_{OL} = 30 \text{ mA}$ for SN54' and 40 mA for SN74'.

switching characteristics, $V_{CC} = 5 \text{ V}$, $T_A = 25^\circ\text{C}$ (see note 3)

| PARAMETER | FROM (INPUT) | TO (OUTPUT) | TEST CONDITIONS | MIN | TYP | MAX | UNIT |
|-----------|-----------------|----------------|--|-----|-----|-----|------|
| | | | | | | | |
| 'PLH | A | Y | $R_L = 110 \Omega$ $C_L = 15 \text{ pF}$ | | 10 | 15 | ns |
| 'PHL | | | | | 15 | 23 | ns |

NOTE 3: Load circuits and voltage waveforms are shown in Section 1

TYPES SN74LS06, SN54LS06 HEX INVERTER BUFFERS/DRIVERS WITH OPEN-COLLECTOR HIGH-VOLTAGE OUTPUTS

D3518, MAY 1990

- Converts TTL Voltage Levels to MOS Levels
- High Sink-Current Capability
- Input Clamping Diodes Simplify System Design
- Open-Collector Driver for Indicator Lamps and Relays
- Package Options Include Standard Plastic (N) and Ceramic (J) 300-mil Dual-In-Line Packages, Plastic Small Outline (D) and Ceramic Chip Carrier (FK) Package

description

These monolithic hex inverter buffers/drivers feature high-voltage open-collector outputs to interface with high-level circuits (such as MOS), or for driving high-current loads, and are also characterized for use as inverter buffers for driving TTL inputs. The 'LS06 has a rated output voltage of 30 V. The maximum sink current for the SN54LS06 is 30 mA and for the SN74LS06 it is 40 mA.

These circuits are compatible with most TTL families. Input are diode-clamped to minimize transmission-effects, which simplifies design. Typical power dissipation is 175 mW and average propagation delay time is 8 ns.

The SN54LS06 is characterized over the full military temperature range of -55°C to 125°C. The SN74LS06 is characterized for Operation from 0°C to 70°C.

logic symbol

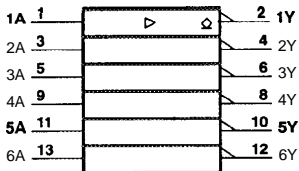

† This symbol is in accordance with ANSI/IEEE Std 91-1964 and IEC Publication 617-12.

Pin numbers shown are for D, J, and N packages.

logic diagram (positive logic)

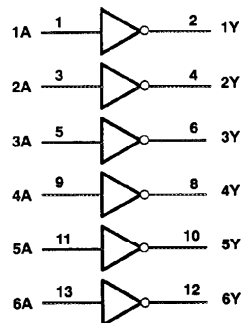

SN54LS06 ... J PACKAGE
SN74LS06 ... D OR N PACKAGE
(TOP VIEW)

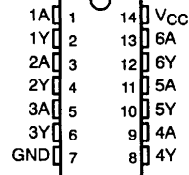

SN54LS06 ... FK PACKAGE
(TOP VIEW)

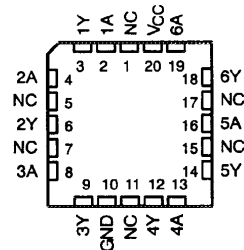

NC - No internal connection

UNLESS OTHERWISE NOTED this document contains PRODUCTION DATA information current as of publication date. Products conform to specifications per the terms of Texas Instruments standard warranty. Production processing does not necessarily include testing of all parameters.

 **TEXAS
INSTRUMENTS**

TYPES SN74LS06, SN54LS06

HEX INVERTER BUFFERS/DRIVERS WITH OPEN-COLLECTOR HIGH-VOLTAGE OUTPUTS

schematic (each gate)

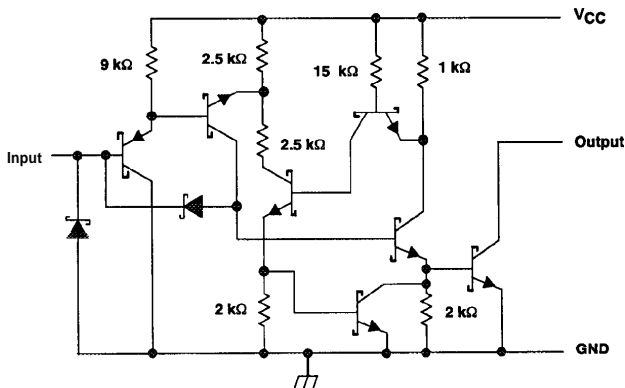

absolute maximum ratings over operating free-air temperature range (unless otherwise noted)†

| | |
|---|----------------|
| Supply voltage, V_{CC} | 7 v |
| Input voltage, V_I (see Note 1) | 5.5 v |
| Output voltage, V_O (see Notes 1 and 2): SN54LS06, SN74LS06 | 30 V |
| Operating free-air temperature range: SN54LS06 | -55°C to 125°C |
| SN74LS06 | 0°C to 70°C |
| Storage temperature range | -65°C to 150°C |

† Stresses beyond those listed under "absolute maximum ratings" may cause permanent damage to the device. This are stress ratings only, and functional operation of the device at these or any other conditions beyond those indicated under "recommended operating conditions" is not implied. Exposure to absolute-maximum-rated conditions for extended periods may affect device reliability.

NOTES: 1. Voltage values are with respect to network ground terminal.

2. This is the maximum voltage that should be applied to any output when it is in the off state.

recommended operating conditions

| | | SN54LS06 | | | SN74LS06 | | | UNIT |
|----------|--------------------------------|----------|-----|-----|----------|-----|------|------|
| | | MIN | NOM | MAX | MIN | NOM | MAX | |
| V_{CC} | Supply voltage | 4.5 | 5 | 5.5 | 4.75 | 5 | 5.25 | V |
| V_{IH} | High-level input voltage | 2 | | | 2 | | | V |
| V_{IL} | Low-level input voltage | | | | 0.8 | | | V |
| V_{OH} | High-level output voltage | | | | 30 | | | V |
| I_{OL} | Low-level output current | | | | 30 | | | mA |
| T_A | Operating free-air temperature | -55 | | | 125 | | | °C |

TYPES SN74LS06, SN54LS06
HEX INVERTER BUFFERS/DRIVERS WITH
OPEN-COLLECTOR HIGH-VOLTAGE OUTPUTS

electrical characteristics over recommended operating free-air temperature range (unless otherwise noted)

| PARAMETER | TEST CONDITIONS† | | SN54LS06 | | | SN74LS06 | | | UNIT |
|-----------|-------------------------|--------------------------|-------------------------------|------|-----|----------|------|-----|---------------|
| | | | MIN | TYP‡ | MAX | MIN | TYP‡ | MAX | |
| V_{IK} | $V_{CC} = \text{MIN}$, | $I_I = -12 \text{ mA}$ | -1.5 | | | -1.5 | | | V |
| I_{OH} | $V_{CC} = \text{MIN}$, | $V_{IL} = 0.8 \text{ V}$ | LS06, $V_{OH} = 30 \text{ V}$ | | | 0.25 | | | mA |
| V_{OL} | $V_{CC} = \text{MIN}$, | $V_{IH} = 2 \text{ V}$ | $I_{OL} = 16 \text{ mA}$ | 0.25 | | 0.4 | | V | |
| | | | $I_{OL} = 30 \text{ mA}$ | 0.7 | | 0.25 | | | |
| | | | $I_{OL} = 40 \text{ mA}$ | | | 0.7 | | | |
| I_I | $V_{CC} = \text{MAX}$, | $V_I = 7 \text{ V}$ | 1 | | | 1 | | | mA |
| I_{IH} | $V_{CC} = \text{MAX}$, | $V_I = 2.4 \text{ V}$ | 20 | | | 20 | | | μA |
| I_{IL} | $V_{CC} = \text{MAX}$, | $V_I = 0.4 \text{ V}$ | -0.2 | | | -0.2 | | | mA |
| I_{CCH} | $V_{CC} = \text{MAX}$ | | 18 | | | 18 | | | mA |
| I_{CCL} | $V_{CC} = \text{MAX}$ | | 60 | | | 60 | | | mA |

† For conditions shown as MIN or MAX, use the appropriate value specified under recommended operating conditions.

‡ All typical values are at $V_{CC} = 5 \text{ V}$, and $T_A = 25^\circ\text{C}$.

switching characteristics, $V_{CC} = 5 \text{ V}$, $T_A = 25^\circ\text{C}$ (see Note 3)

| PARAMETER | FROM (INPUT) | TO (OUTPUT) | TEST CONDITIONS | | MIN | TYP | MAX | UNIT |
|-----------|--------------|-------------|----------------------|-----------------------|-----|-----|-----|------|
| t_{PLH} | A | Y | $R_L = 110 \Omega$, | $C_L = 15 \text{ pF}$ | 7 | | 15 | ns |
| t_{PHL} | | | | | 10 | | 20 | |

NOTE 3: Load circuit and voltage waveforms are shown in Section 1.