

# 9A SYNCHRONOUS BUCK SWITCHING REGULATOR WITH 1MHz OPERATION FREQUENCY

PRELIMINARY DATA SHEET

Pb Free Product

## DESCRIPTION

The NX9511B is synchronous buck switching converter in multi chip module designed for step down DC to DC converter applications. They are optimized to convert bus voltages from 2V to 25V to as low as 0.8V output voltage. The output current can be up to 9A. The NX9511B offer an Enable pin that can be used to program the converter's start up. NX9511B operates at fixed internal frequency of 1MHz and employ loss-less current limiting protection by sensing the R<sub>dson</sub> of synchronous MOSFET followed by latch out feature. Feedback under voltage triggers Hiccup.

Other features are: Internal digital soft start; V<sub>cc</sub> undervoltage lock out and shutdown capability via the enable pin or comp pin. NX9511B is available in 5x5 MCM package.

- Switching Controller and MOSFETs in one package
- Bus voltage operation from 2V to 25V
- Fixed 1MHz
- Internal Digital Soft Start Function
- Output current up to 9A
- Enable pin to program BUS UVLO
- Programmable current limit triggers latch out by sensing R<sub>dson</sub> of Synchronous MOSFET
- No negative spike at V<sub>out</sub> during startup and shutdown
- Pb-free and RoHS compliant

## FEATURES

## APPLICATIONS

- Low Profile On board DC to DC Application
- Graphic Card on board converters
- Memory V<sub>ddq</sub> Supply
- ADSL Modem

## TYPICAL APPLICATION

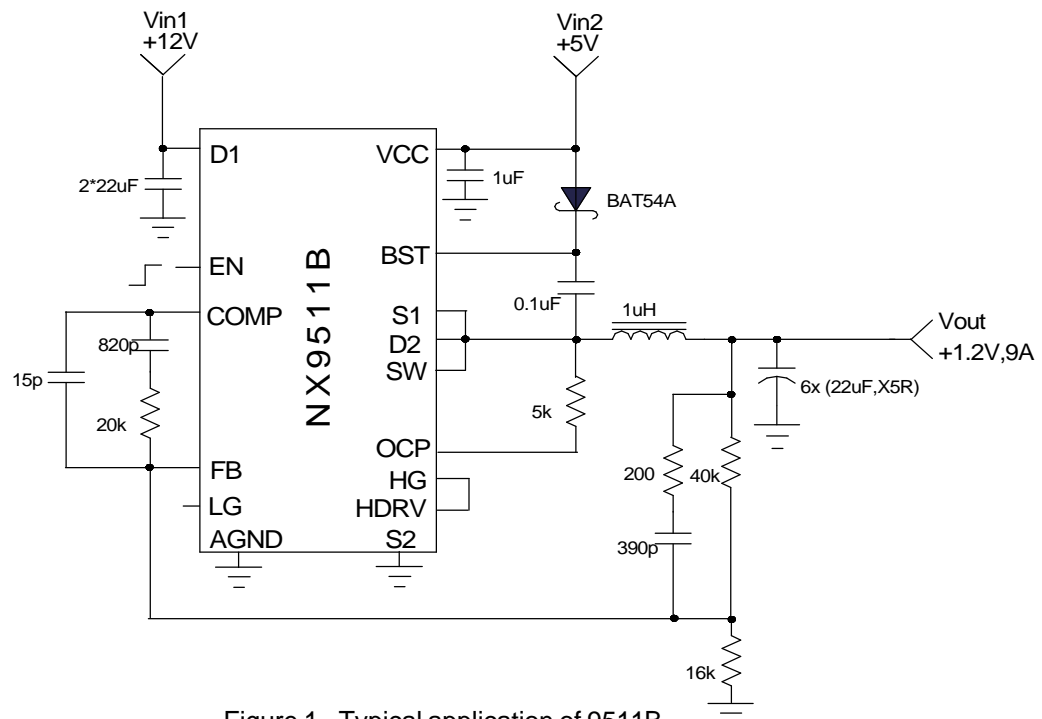


Figure 1 - Typical application of 9511B

## ORDERING INFORMATION

Device	Temperature	Package	Frequency	Pb-Free
NX9511BCMTR	0 to 70°C	5X5 MCM-32L	1MHz	Yes

## ABSOLUTE MAXIMUM RATINGS

VCC to GND & BST to SW voltage .....	-0.3V to 6.5V
D1 to GND .....	25V
BST to GND Voltage .....	-0.3V to 35V
D2,S1 to GND .....	-2V to 35V
All other pins .....	-0.3V to VCC+0.3V or 6.5V
Storage Temperature Range .....	-65°C to 150°C
Operating Junction Temperature Range .....	-40°C to 125°C
ESD Susceptibility .....	2kV
Power Dissipation .....	TBD
Output Current .....	TBD

CAUTION: Stresses above those listed in "ABSOLUTE MAXIMUM RATINGS", may cause permanent damage to the device. This is a stress only rating and operation of the device at these or any other conditions above those indicated in the operational sections of this specification is not implied.

---



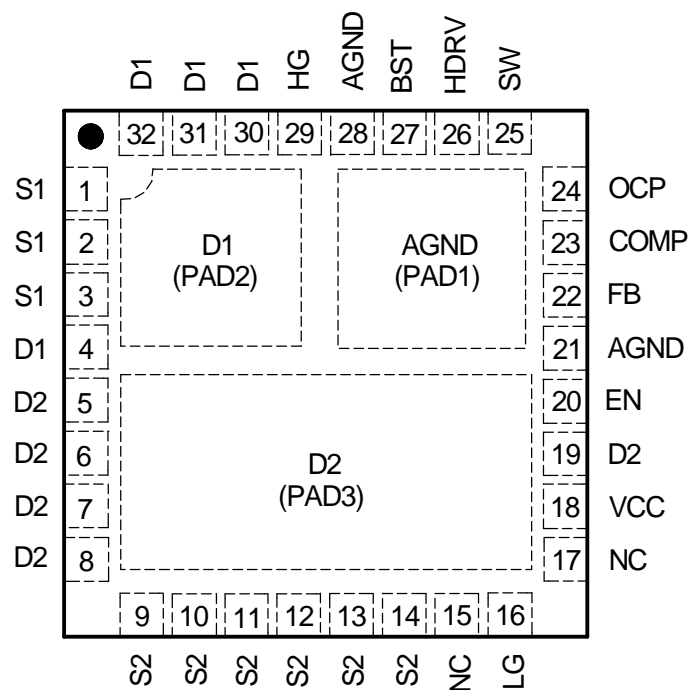
---

## PACKAGE INFORMATION

---

32-LEAD PLASTIC MCM 5 x 5

---



**ELECTRICAL SPECIFICATIONS**

Unless otherwise specified, these specifications apply over  $V_{CC} = 5V$ ,  $V_{IN} = 12V$  and  $T_A = 0$  to  $70^\circ C$ . Typical values refer to  $T_A = 25^\circ C$ . Low duty cycle pulse testing is used which keeps junction and case temperatures equal to the ambient temperature.

PARAMETER	SYM	Test Condition	Min	TYP	MAX	Units
<b>Reference Voltage</b>						
Ref Voltage	$V_{REF}$			0.8		V
Ref Voltage line regulation				0.2		%
<b>Supply Voltage(<math>V_{CC}</math>)</b>						
$V_{CC}$ Voltage Range	$V_{CC}$		4.5	5	5.5	V
$V_{CC}$ Supply Current (Static)	$I_{CC}$ (Static)	Outputs not switching		3		mA
<b>Supply Voltage(<math>V_{BST}</math>)</b>						
$V_{BST}$ Supply Current (Static)	$I_{BST}$ (Static)	Outputs not switching		0.2		mA
$V_{CC}$ , $V_{BST}$ Supply Current (Dynamic)	$I$ (Dynamic)			15		mA
<b>Under Voltage Lockout</b>						
$V_{CC}$ -Threshold	$V_{CC\_UVLO}$	$V_{CC}$ Rising		4		V
$V_{CC}$ -Hysteresis	$V_{CC\_Hyst}$	$V_{CC}$ Falling		0.2		V
<b>Oscillator</b>						
Frequency	$F_S$			1		MHz
Ramp-Amplitude Voltage	$V_{RAMP}$			1.5		V
Max Duty Cycle				75		%
Min Duty Cycle					0	%
<b>Error Amplifiers</b>						
Transconductance				2000		umho
Input Bias Current	$I_b$			10		nA
<b>EN &amp; SS</b>						
Soft Start time	$T_{SS}$			2		mS
Enable HI Threshold				1.25		V
Enable Hysteresis				150		mV
<b>Output Stage</b>						
High Side MOSFET $R_{DS(ON)}$				17		ohm
Low Side MOSFET $R_{DS(ON)}$				17		ohm
Output Current				9		A
<b>OCP Adjust</b>						
OCP current				40		uA
<b>FB Under Voltage Protection</b>						
FB Under Voltage Threshold				0.48		V

## PIN DESCRIPTIONS

PIN #	PIN SYMBOL	PIN DESCRIPTION
1-3	S1	Bus input which is connected to high side MOSFET's drain.
5-8,19	D2	Drain of low side MOSFET.
9-14	S2	Source of low side MOSFET and need to be connected to power ground.
15,17	NC	
16	LG	Low side gate driver output for monitoring.
18	VCC	Power supply voltage. A high freq 1uF ceramic capacitor is placed as close as possible to and connected to this pin and ground pin. The maximum rating of this pin is 5V.
20	EN	External enable signal input for the controller.
22	FB	This pin is the error amplifier inverting input. It is connected via resistor divider to the output of the switching regulator to set the output DC voltage. When FB pin voltage is lower than 0.6V, hiccup circuit starts to recycle the soft start circuit after 2048 switching cycles.
23	COMP	This pin is the output of error amplifier and is used to compensate the voltage control feedback loop. This pin can also be used to perform a shutdown if pulled lower than 0.3V.
24	OCP	This pin is connected to the drain of the external low side MOSFET via resistor and is the input of the over current protection(OCP) comparator. An internal current source 40uA is flown to the external resistor which sets the OCP voltage across the Rds-on of the low side MOSFET. Current limit point is this voltage divided by the Rds-on. Once this threshold is reached the Hdrv and Ldrv pins are latched out. Ground pin.
25	SW	SW is the controller pin out which needs to be connected to S1 and D2 and provides return path for the high side driver.
26	HDRV	High side gate driver output which needs to be connected high side MOSFET gate HG.
27	BST	This pin supplies voltage to high side FET driver. A high freq 0.1uF ceramic capacitor is placed as close as possible to and connected to these pins and respected SW pins.
21,28	AGND	Analog ground.
29	HG	High side MOSFET gate which needs to be connected to high side gate driver output HDRV.
30-32,4	D1	Drain of High side MOSFET.

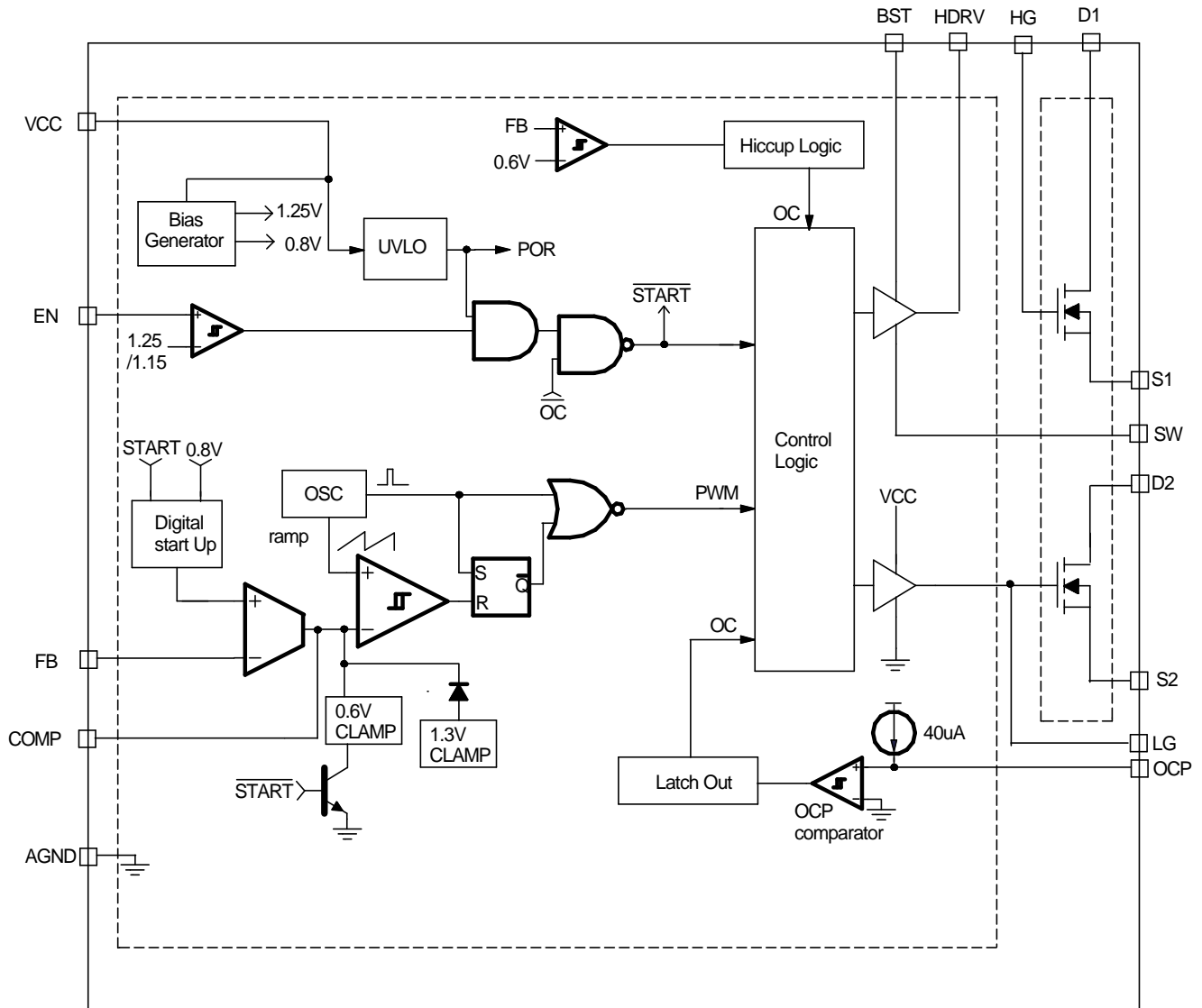
**BLOCK DIAGRAM**


Figure 2 - Simplified block diagram of the NX9511B

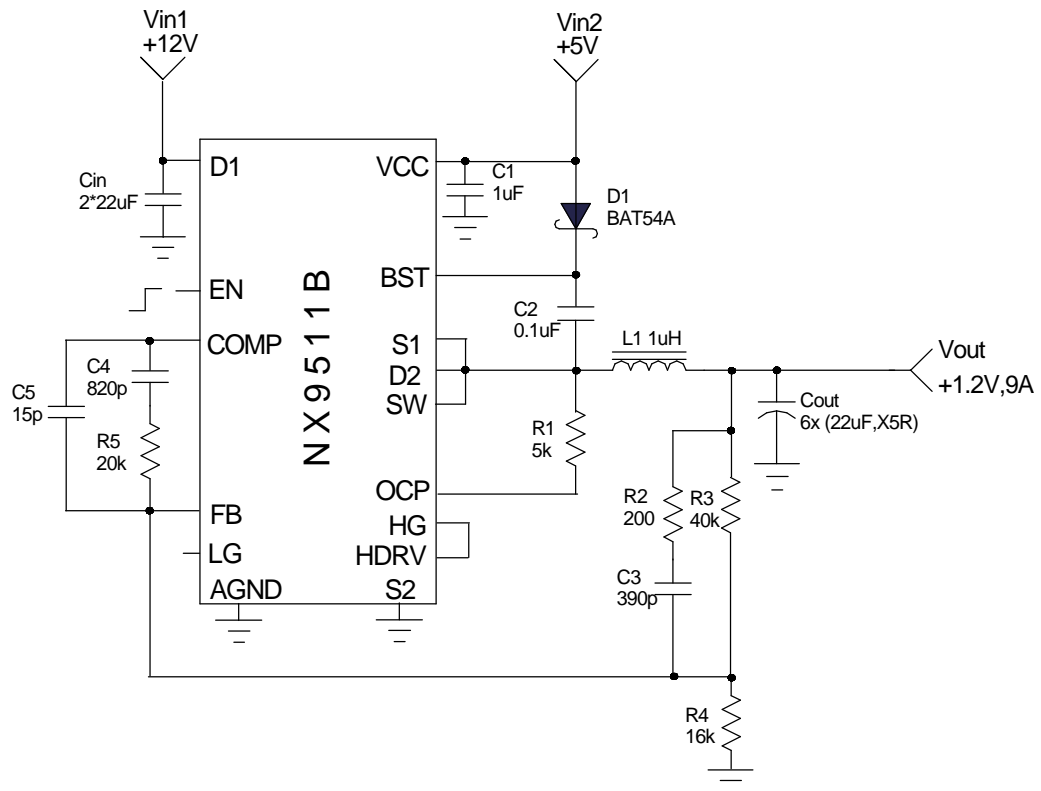
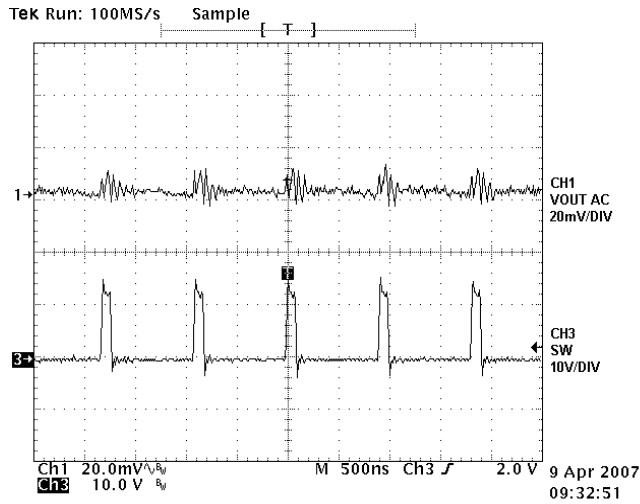
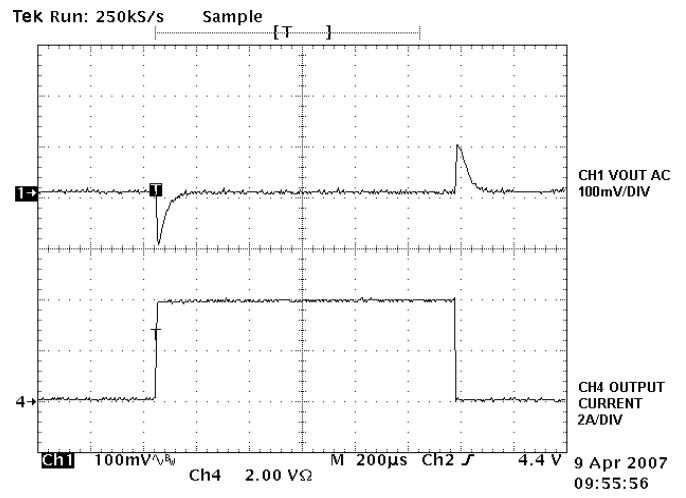
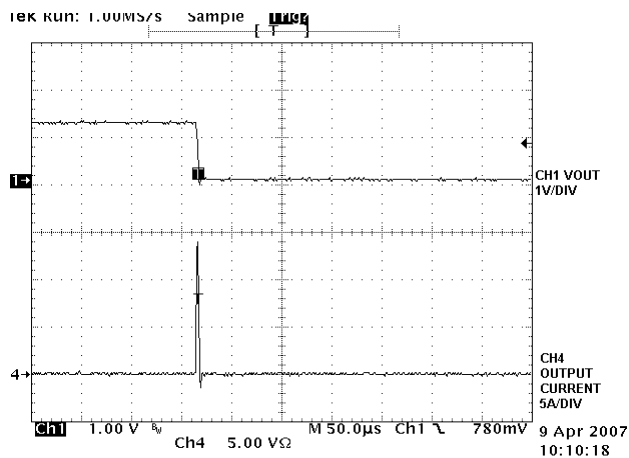
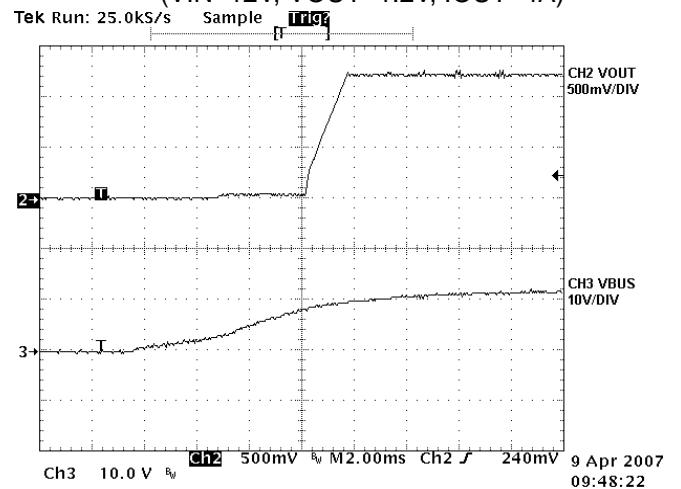
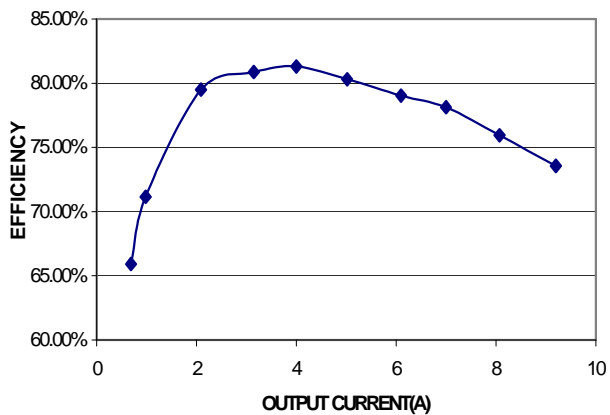


Figure 3- Demo board schematic

**Bill of Materials**

Item	Quantity	Reference	Value	Manufacture
1	1	C1	1u	
2	1	C2	0.1u	
3	1	C5	15p	
4	8	Cin,Cout	22u	
5	1	C4	820p	
6	1	C3	390p	
7	1	D1	BAT54A	
8	1	L2	DO3316P-102HC	Coilcraft
9	1	R5	20k	
10	1	R3	40k	
11	1	R2	200	
12	1	R4	16k	
13	1	U1	NX9511B/MLPQ32	
14	1	U2	L78L05AB/sot89	NEXSEM INC.

**Demoboard waveforms**

**Figure 4 - Output ripple (VIN=12V,VOUT=1.2V)**

**Figure 5 - Output voltage transient response (VIN=12V, VOUT=1.2V, IOUT=4A)**

**Figure 6 - Over current protection**

**Figure 7 - Startup**

**Figure 8 - Output Efficiency @VOUT=1.2V,VIN=12V**



Efficiency v.s. Output Voltage  
 $V_{in}=12V$   $I_{out}=4A$

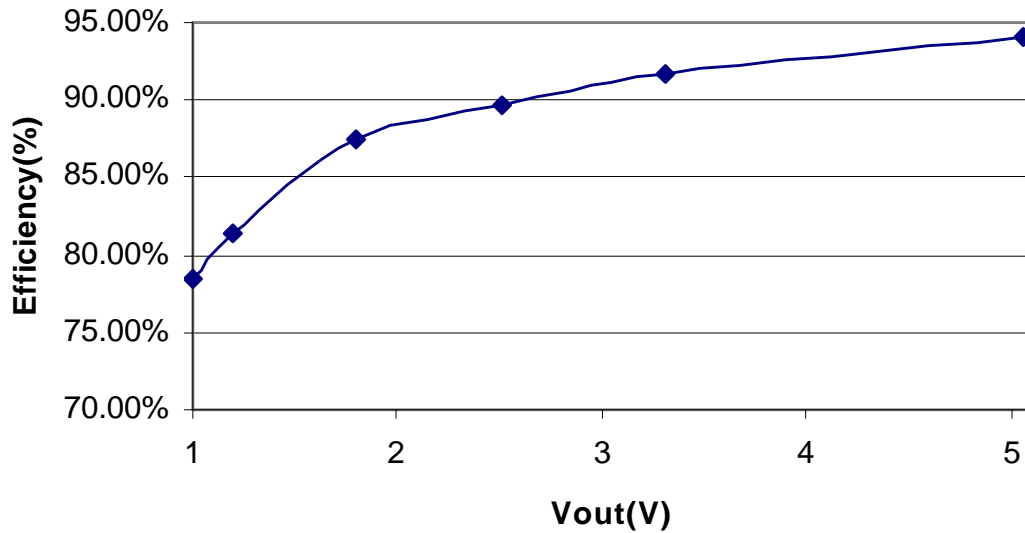


Figure 9 - Output Efficiency

Efficiency v.s. Output Voltage  
 $V_{in}=12V$   $I_{out}=6A$

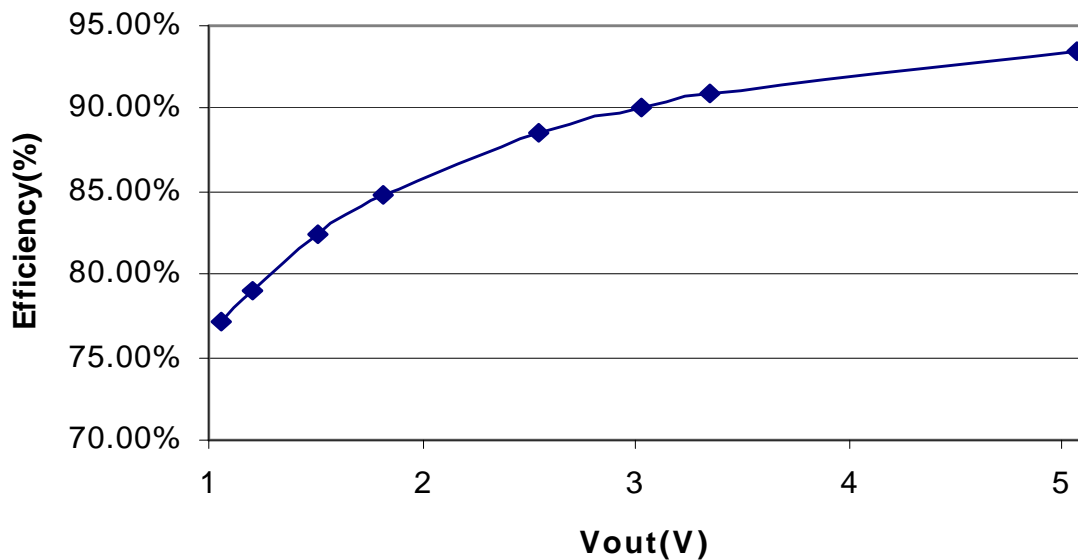


Figure 10 - Output Efficiency

Efficiency v.s. Output Voltage  
 $V_{in}=12V$   $I_{out}=8A$

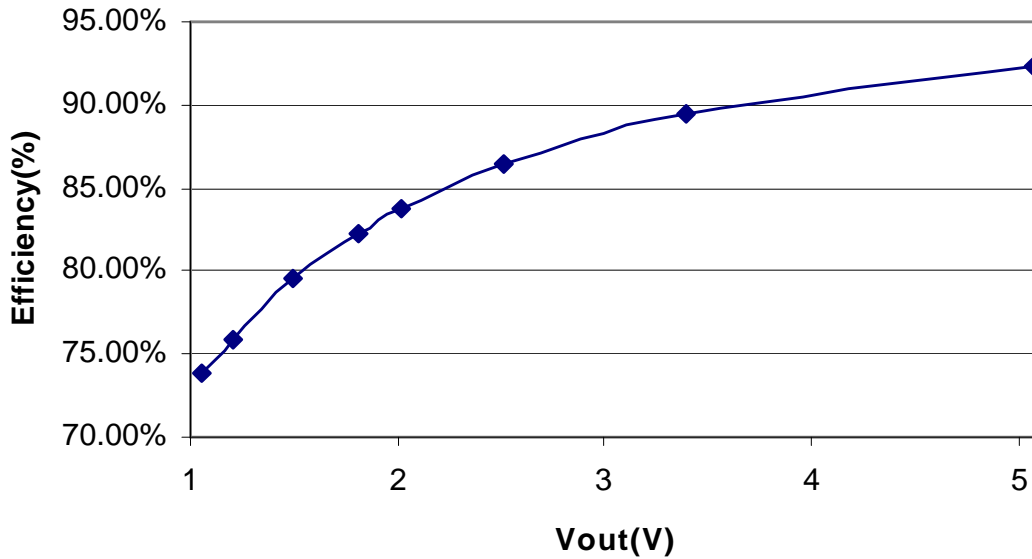


Figure 11 - Output Efficiency

Efficiency v.s. Output Voltage  
 $V_{in}=12V$   $I_{out}=9A$

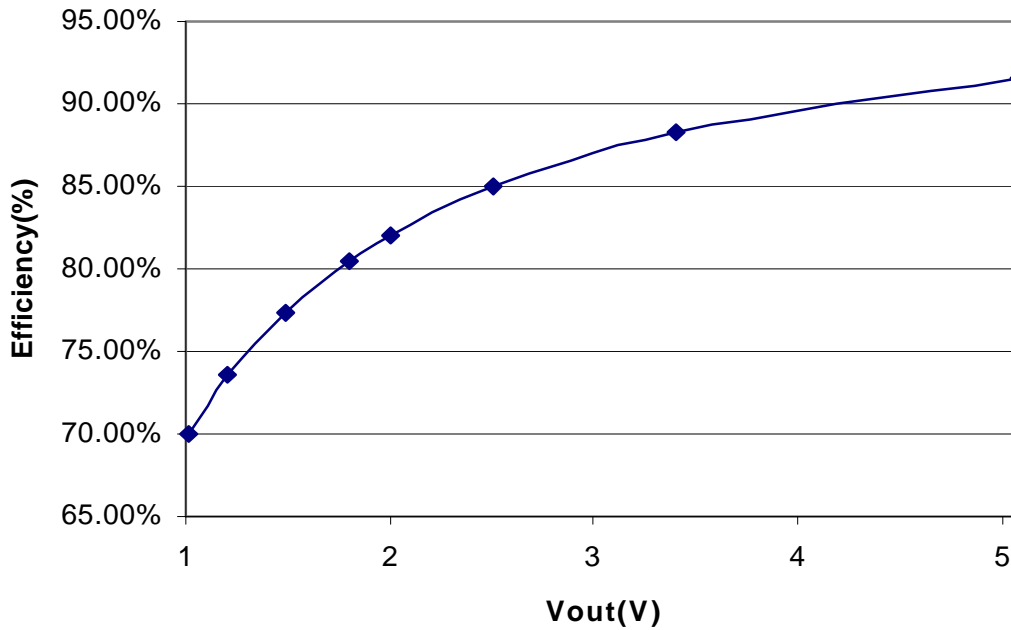


Figure 12 - Output Efficiency

**Typical application**

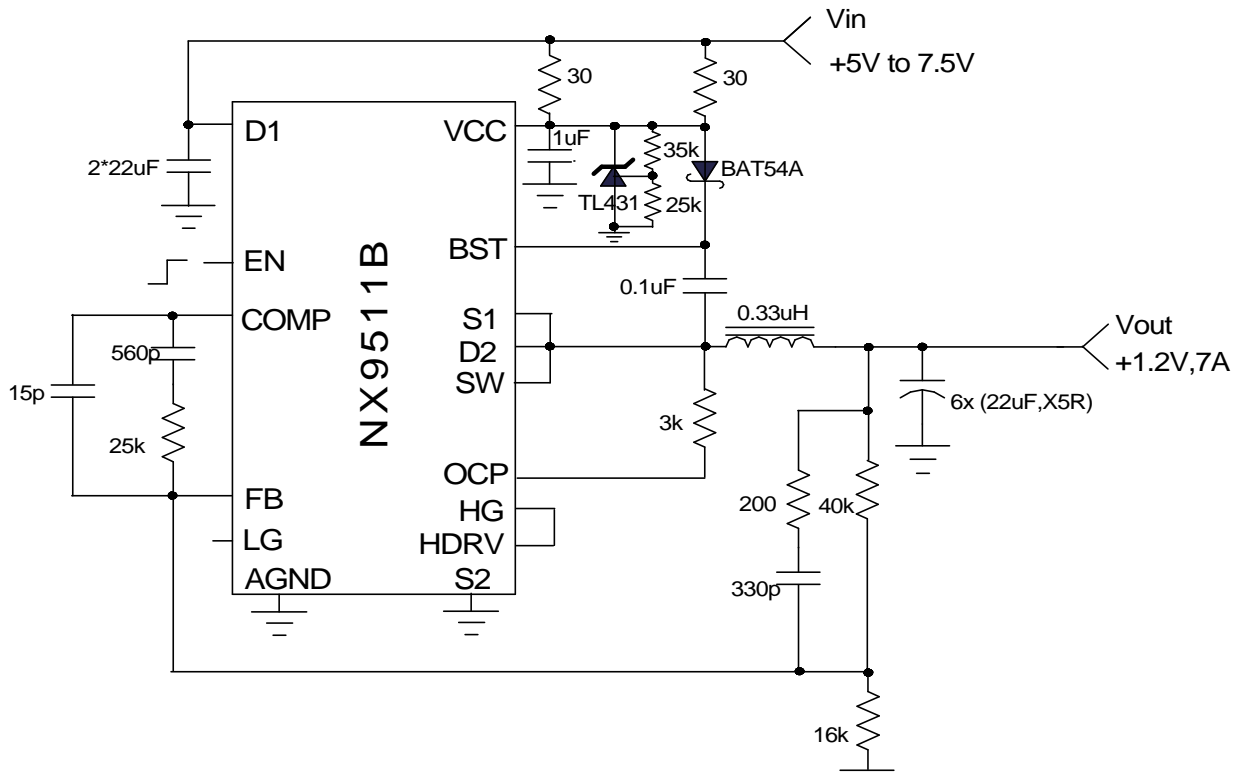


Figure 13 - Typical application of 9511B

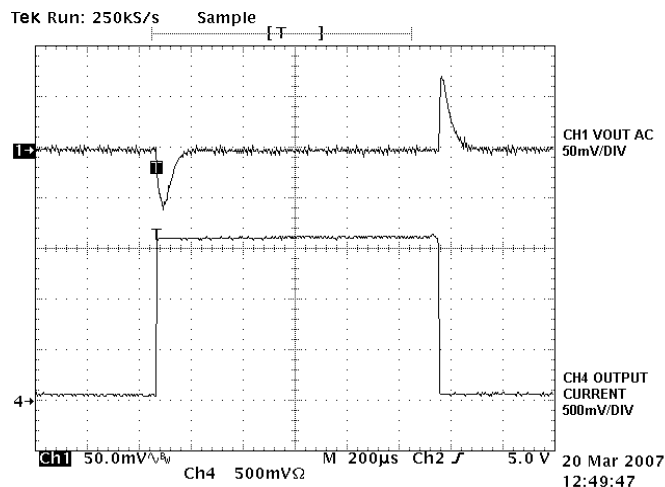


Figure 14 - Output voltage transient response (VIN=5V, VOUT=1.2V, IOUT=1.5A)

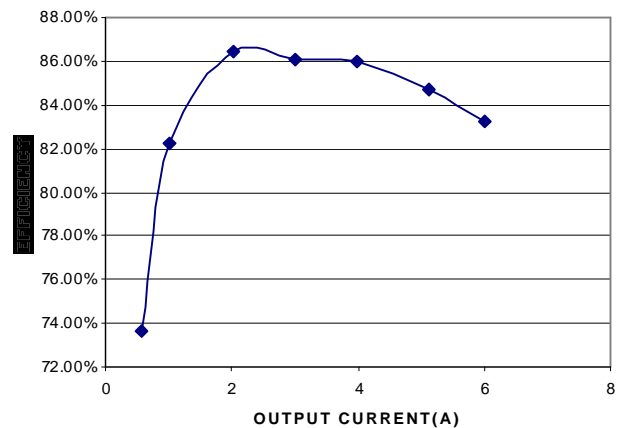


Figure 15 - Output Efficiency @ VOUT=1.2V, VIN=5V

## APPLICATION INFORMATION

### Symbol Used In Application Information:

- $V_{IN}$  - Input voltage
- $V_{OUT}$  - Output voltage
- $I_{OUT}$  - Output current
- $\Delta V_{RIPPLE}$  - Output voltage ripple
- $F_S$  - Working frequency
- $\Delta I_{RIPPLE}$  - Inductor current ripple

### Design Example

The following is typical application for NX9511B:

- $V_{IN} = 12V$
- $V_{OUT} = 1.8V$
- $F_S = 1000kHz$
- $I_{OUT} = 9A$
- $\Delta V_{RIPPLE} \leq 20mV$
- $\Delta V_{DROOP} \leq 100mV @ 9A \text{ step}$

### Output Inductor Selection

The selection of inductor value is based on inductor ripple current, power rating, working frequency and efficiency. Larger inductor value normally means smaller ripple current. However if the inductance is chosen too large, it brings slow response and lower efficiency. Usually the ripple current ranges from 20% to 40% of the output current. This is a design freedom which can be decided by design engineer according to various application requirements. The inductor value can be calculated by using the following equations:

$$L_{OUT} = \frac{V_{IN} - V_{OUT}}{\Delta I_{RIPPLE}} \times \frac{V_{OUT}}{V_{IN}} \times \frac{1}{F_S} \quad \dots(1)$$

$$I_{RIPPLE} = k \times I_{OUTPUT}$$

where k is between 0.2 to 0.4.

Select  $k=0.3$ , then

$$L_{OUT} = \frac{12V - 1.8V}{0.4 \times 9A} \times \frac{1.8V}{12V} \times \frac{1}{1000kHz}$$

$$L_{OUT} = 0.42\mu H$$

Choose inductor from COILCRAFT DO3316H-681MLD with  $L=0.68\mu H$  is a good choice.

Current Ripple is recalculated as

$$\Delta I_{RIPPLE} = \frac{V_{IN} - V_{OUT}}{L_{OUT}} \times \frac{V_{OUT}}{V_{IN}} \times \frac{1}{F_S}$$

$$= \frac{12V - 1.8V}{0.68\mu H} \times \frac{1.8V}{12V} \times \frac{1}{1000kHz} = 2.25A \quad \dots(2)$$

### Output Capacitor Selection

Output capacitor is basically decided by the amount of the output voltage ripple allowed during steady state(DC) load condition as well as specification for the load transient. The optimum design may require a couple of iterations to satisfy both condition.

The amount of voltage ripple during the DC load condition is determined by equation(3).

$$\Delta V_{RIPPLE} = ESR \times \Delta I_{RIPPLE} + \frac{\Delta I_{RIPPLE}}{8 \times F_S \times C_{OUT}} \quad \dots(3)$$

Where ESR is the output capacitors' equivalent series resistance,  $C_{OUT}$  is the value of output capacitors.

Typically ceramic capacitors are selected as output capacitors in NX9811B applications. DC ripple spec is easy to be met, usually multiple ceramic capacitors are required at the output to meet transient requirement. In this example, two 47 $\mu F$ , X5R are used.

### Compensator Design

Due to the double pole generated by LC filter of the power stage, the power system has 180° phase shift, and therefore, is unstable by itself. In order to achieve accurate output voltage and fast transient response, compensator is employed to provide highest possible bandwidth and enough phase margin. Ideally, the Bode plot of the closed loop system has crossover frequency between 1/10 and 1/5 of the switching frequency, phase margin greater than 50° and the gain crossing 0dB with -20dB/decade. Power stage output capacitors usually decide the compensator type. If electrolytic capacitors are chosen as output capacitors, type II compensator can be used to compensate the system, because the zero caused by output capacitor ESR is lower than crossover frequency. Otherwise type III compensator should be chosen.

### A. Type III compensator design

For low ESR output capacitors, typically such as Sanyo oscap and poscap, the frequency of ESR zero caused by output capacitors is higher than the cross-over frequency. In this case, it is necessary to compensate the system with type III compensator. The following figures and equations show how to realize the type III compensator by transconductance amplifier.

$$F_{Z1} = \frac{1}{2 \times \pi \times R_4 \times C_2} \quad \dots(4)$$

$$F_{Z2} = \frac{1}{2 \times \pi \times (R_2 + R_3) \times C_3} \quad \dots(5)$$

$$F_{P1} = \frac{1}{2 \times \pi \times R_3 \times C_3} \quad \dots(6)$$

$$F_{P2} = \frac{1}{2 \times \pi \times R_4 \times \frac{C_1 \times C_2}{C_1 + C_2}} \quad \dots(7)$$

where  $F_{Z1}, F_{Z2}, F_{P1}$  and  $F_{P2}$  are poles and zeros in the compensator. Their locations are shown in figure 4.

The transfer function of type III compensator for transconductance amplifier is given by:

$$\frac{V_e}{V_{OUT}} = \frac{1 - g_m \times Z_f}{1 + g_m \times Z_{in} + Z_{in} / R_1}$$

For the voltage amplifier, the transfer function of compensator is

$$\frac{V_e}{V_{OUT}} = \frac{-Z_f}{Z_{in}}$$

To achieve the same effect as voltage amplifier, the compensator of transconductance amplifier must satisfy this condition:  $R_4 \gg 2/g_m$ . And it would be desirable if  $R_1 || R_2 || R_3 \gg 1/g_m$  can be met at the same time.

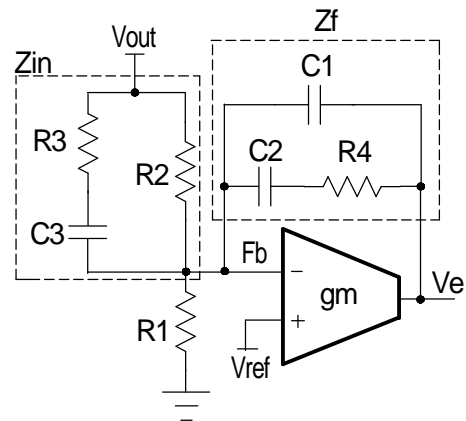


Figure 16 - Type III compensator using transconductance amplifier

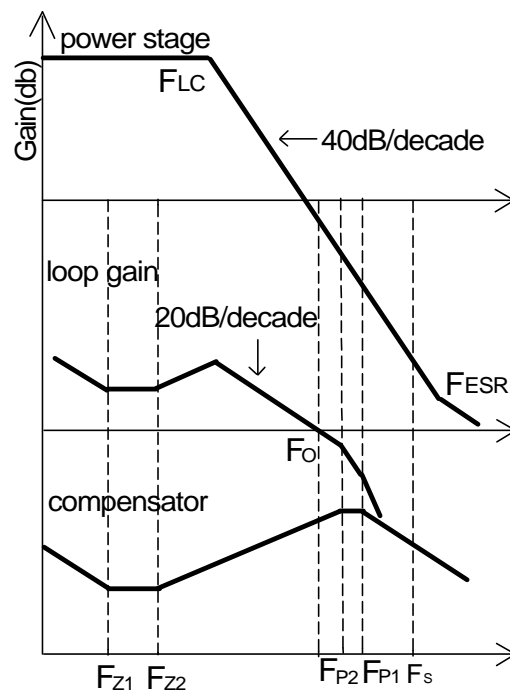


Figure 17 - Bode plot of Type III compensator

Design example for type III compensator are in order. The crossover frequency has to be selected as  $F_{LC} < F_o < F_{ESR}$ , and  $F_o \approx 1/10 \sim 1/5 F_s$ .

1. Calculate the location of LC double pole  $F_{LC}$  and ESR zero  $F_{ESR}$ .

$$F_{LC} = \frac{1}{2 \times \pi \times \sqrt{L_{OUT} \times C_{OUT}}}$$

$$= \frac{1}{2 \times \pi \times \sqrt{0.68 \mu H \times 94 \mu F}}$$

$$= 20 \text{ kHz}$$

$$F_{ESR} = \frac{1}{2 \times \pi \times ESR \times C_{OUT}}$$

$$= \frac{1}{2 \times \pi \times 0.5 \text{ m}\Omega \times 94 \mu F}$$

$$= 3.4 \text{ MHz}$$

2. Set  $R_2$  equal to 20k $\Omega$ .

$$R_1 = \frac{R_2 \times V_{REF}}{V_{OUT} - V_{REF}} = \frac{60 \text{ k}\Omega \times 0.8 \text{ V}}{1.8 \text{ V} - 0.8 \text{ V}} = 48 \text{ k}\Omega$$

Choose  $R_1 = 48 \text{ k}\Omega$ .

3. Set zero  $F_{z2} = 0.75 F_{LC}$  and  $F_{p1} = F_{ESR}$ .

4. Calculate  $R_4$  and  $C_3$  with the crossover

frequency at 1/10~ 1/5 of the switching frequency. Set  $F_o = 100 \text{ kHz}$ .

$$C_3 = \frac{1}{2 \times \pi \times R_2} \times \left( \frac{1}{F_{z2}} - \frac{1}{F_{p1}} \right)$$

$$= \frac{1}{2 \times \pi \times 60 \text{ k}\Omega} \times \left( \frac{1}{15 \text{ kHz}} - \frac{1}{3.4 \text{ MHz}} \right)$$

$$= 180 \text{ pF}$$

$$R_4 = \frac{V_{OSC}}{V_{in}} \times \frac{2 \times \pi \times F_o \times L}{C_3} \times C_{out}$$

$$= \frac{1.5 \text{ V}}{12 \text{ V}} \times \frac{2 \times \pi \times 100 \text{ kHz} \times 0.68 \mu H}{180 \text{ pF}} \times 94 \mu F$$

$$= 28 \text{ k}\Omega$$

Choose  $C_3 = 180 \text{ pF}$ ,  $R_4 = 30 \text{ k}\Omega$ .

5. Calculate  $C_2$  with zero  $F_{z1}$  at 50% of the LC double pole by equation (11).

$$C_2 = \frac{1}{2 \times \pi \times F_{z1} \times R_4}$$

$$= \frac{1}{2 \times \pi \times 0.5 \times 20 \text{ kHz} \times 30 \text{ k}\Omega}$$

$$= 533 \text{ pF}$$

Choose  $C_2 = 520 \text{ pF}$ .

6. Calculate  $C_1$  by equation (14) with pole  $F_{p2}$  at half the switching frequency.

$$C_1 = \frac{1}{2 \times \pi \times R_4 \times F_{p2}}$$

$$= \frac{1}{2 \times \pi \times 30 \text{ k}\Omega \times 500 \text{ kHz}}$$

$$= 10 \text{ pF}$$

Choose  $C_1 = 12 \text{ pF}$ .

7. Calculate  $R_3$  by equation (13).

$$R_3 = \frac{1}{2 \times \pi \times F_{p1} \times C_3}$$

$$= \frac{1}{2 \times \pi \times 3.4 \text{ MHz} \times 180 \text{ pF}}$$

$$= 261 \Omega$$

Choose  $R_3 = 300 \Omega$ .

## Output Voltage Calculation

Output voltage is set by reference voltage and external voltage divider. The reference voltage is fixed at 0.8V. The divider consists of two ratioed resistors so that the output voltage applied at the Fb pin is 0.8V when the output voltage is at the desired value. The following equation and picture show the relationship between  $V_{OUT}$ ,  $V_{REF}$  and voltage divider.

$$R_1 = \frac{R_2 \times V_{REF}}{V_{OUT} - V_{REF}} \quad \dots(8)$$

where  $R_2$  is part of the compensator, and the value of  $R_1$  value can be set by voltage divider.

See compensator design for  $R_1$  and  $R_2$  selection.

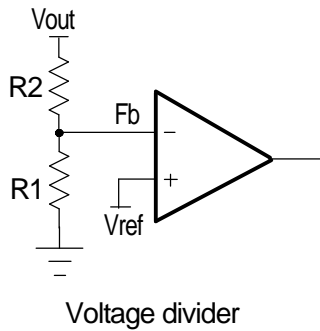


Figure 18 - Voltage divider

### Soft Start and Enable

NX9511B has digital soft start for switching controller and has one enable pin for this start up. When the Power Ready (POR) signal is high and the voltage at enable pin is above 1.25V the internal digital counter starts to operate and the voltage at positive input of Error amplifier starts to increase, the feedback network will force the output voltage follows the reference and starts the output slowly. After 2048 cycles, the soft start is complete and the output voltage is regulated to the desired voltage decided by the feedback resistor divider.

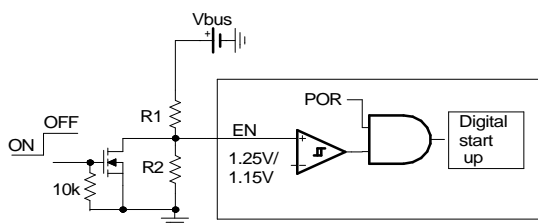


Figure 19 - Enable and Shut down the NX9511B with Enable pin.

The start up of NX9511B can be programmed through resistor divider at Enable pin. For example, if the input bus voltage is 12V and we want NX9511B starts when Vbus is above 9V. We can select using the following equation.

$$R_1 = \frac{(9V - 1.25V) \times R_2}{1.25V}$$

The NX9511B can be turned off by pulling down the Enable pin by extra signal MOSFET as shown in the above Figure. When Enable pin is below 1.25V, the digital soft start is reset to zero. In addition, all the high side and low side driver is off and no negative spike will be generated during the turn off.

### Over Current Protection

Over current protection is achieved by sensing current through the low side MOSFET. An internal current source of 40uA flows through an external resistor connected from OCP pin to SW node sets the over current protection threshold. When synchronous FET is on, the voltage at node SW is given as

$$V_{SW} = -I_L \times R_{DSON}$$

The voltage at pin OCP is given as

$$I_{OCP} \times R_{OCP} + V_{SW}$$

When the voltage is below zero, the over current occurs.

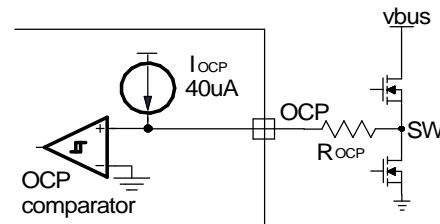


Figure 20 - Over current protection

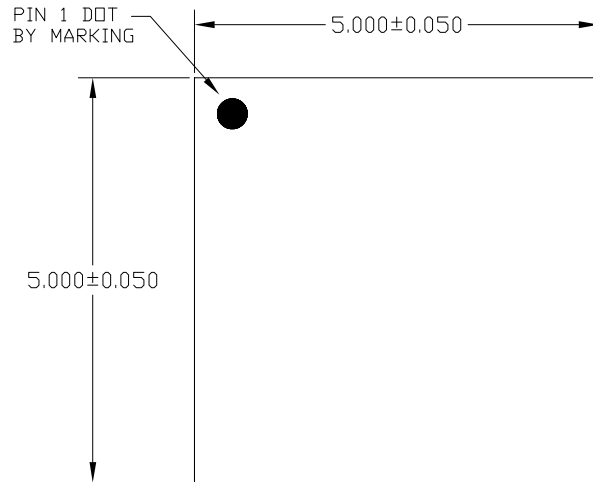
The over current limit can be set by the following equation

$$I_{SET} = \frac{I_{OCP} \times R_{OCP}}{K \times R_{DSON}}$$

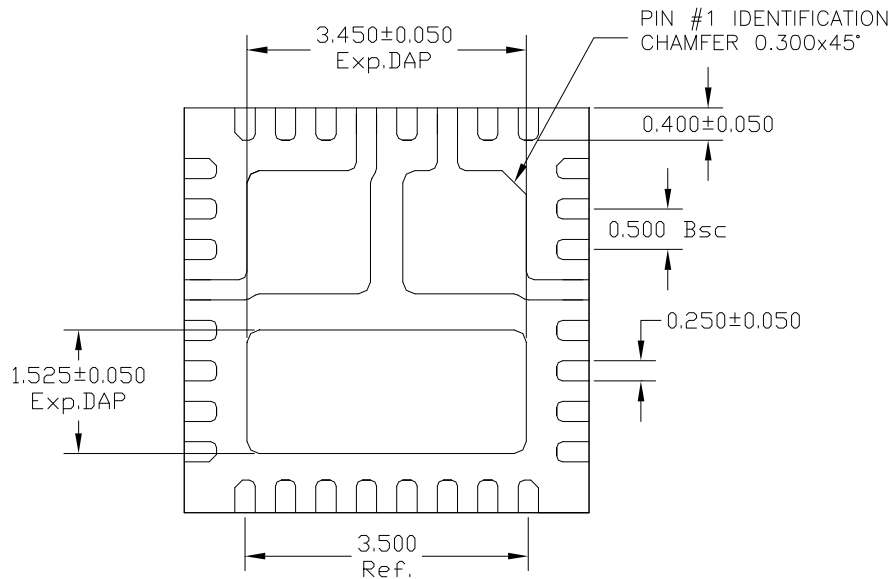
The internal MOSFET  $R_{DSON} = 17m\Omega$ , the worst case thermal consideration  $K = 1.3$  and the current limit is set at 10A, then

$$R_{OCP} = \frac{I_{SET} \times K \times R_{DSON}}{I_{OCP}} = \frac{10A \times 1.3 \times 17m\Omega}{40\mu A} = 5.5k\Omega$$

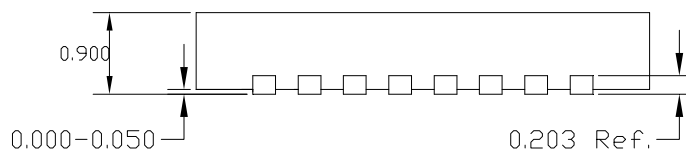
Choose  $R_{OCP} = 5.5k\Omega$

**MLPQ 32 PIN 5 x 5 PACKAGE OUTLINE DIMENSIONS**


TOP VIEW



BOTTOM VIEW



SIDE VIEW

NOTE: ALL DIMENSIONS ARE DISPLAYED IN MILLIMETERS.