

SECTION 7

TEMPERATURE SENSORS

Walt Kester, James Bryant, Walt Jung

INTRODUCTION

Measurement of temperature is critical in modern electronic devices, especially expensive laptop computers and other portable devices with densely packed circuits which dissipate considerable power in the form of heat. Knowledge of system temperature can also be used to control battery charging as well as prevent damage to expensive microprocessors.

Compact high power portable equipment often has fan cooling to maintain junction temperatures at proper levels. In order to conserve battery life, the fan should only operate when necessary. Accurate control of the fan requires a knowledge of critical temperatures from the appropriate temperature sensor.

APPLICATIONS OF TEMPERATURE SENSORS

- **Monitoring**
 - ◆ **Portable Equipment**
 - ◆ **CPU Temperature**
 - ◆ **Battery Temperature**
 - ◆ **Ambient Temperature**

- **Compensation**
 - ◆ **Oscillator Drift in Cellular Phones**
 - ◆ **Thermocouple Cold-Junction Compensation**

- **Control**
 - ◆ **Battery Charging**
 - ◆ **Process Control**

Figure 7.1

Accurate temperature measurements are required in many other measurement systems such as process control and instrumentation applications. In most cases, because of low-level nonlinear outputs, the sensor output must be properly conditioned and amplified before further processing can occur.

Except for IC sensors, all temperature sensors have nonlinear transfer functions. In the past, complex analog conditioning circuits were designed to correct for the sensor nonlinearity. These circuits often required manual calibration and precision resistors to achieve the desired accuracy. Today, however, sensor outputs may be

TEMPERATURE SENSORS

digitized directly by high resolution ADCs. Linearization and calibration is then performed digitally, thereby reducing cost and complexity.

Resistance Temperature Devices (RTDs) are accurate, but require excitation current and are generally used in bridge circuits. Thermistors have the most sensitivity but are the most non-linear. However, they are popular in portable applications such as measurement of battery temperature and other critical temperatures in a system.

Modern semiconductor temperature sensors offer high accuracy and high linearity over an operating range of about -55°C to $+150^{\circ}\text{C}$. Internal amplifiers can scale the output to convenient values, such as $10\text{mV}/^{\circ}\text{C}$. They are also useful in cold-junction-compensation circuits for wide temperature range thermocouples. Semiconductor temperature sensors can be integrated into multi-function ICs which perform a number of other hardware monitoring functions.

Figure 7.2 lists the most popular types of temperature transducers and their characteristics.

TYPES OF TEMPERATURE SENSORS

THERMOCOUPLE	RTD	THERMISTOR	SEMICONDUCTOR
Widest Range: -184°C to $+2300^{\circ}\text{C}$	Range: -200°C to $+850^{\circ}\text{C}$	Range: 0°C to $+100^{\circ}\text{C}$	Range: -55°C to $+150^{\circ}\text{C}$
High Accuracy and Repeatability	Fair Linearity	Poor Linearity	Linearity: 1°C Accuracy: 1°C
Needs Cold Junction Compensation	Requires Excitation	Requires Excitation	Requires Excitation
Low-Voltage Output	Low Cost	High Sensitivity	$10\text{mV}/\text{K}$, $20\text{mV}/\text{K}$, or $1\mu\text{A}/\text{K}$ Typical Output

Figure 7.2

THERMOCOUPLE PRINCIPLES AND COLD-JUNCTION COMPENSATION

Thermocouples are small, rugged, relatively inexpensive, and operate over the widest range of all temperature sensors. They are especially useful for making measurements at extremely high temperatures (up to $+2300^{\circ}\text{C}$) in hostile environments. They produce only millivolts of output, however, and require precision amplification for further processing. They also require cold-junction-compensation (CJC) techniques which will be discussed shortly. They are more linear than many other sensors, and their non-linearity has been well characterized. Some common thermocouples are shown in Figure 7.3. The most common metals used are Iron, Platinum, Rhodium, Rhenium, Tungsten, Copper, Alumel (composed

of Nickel and Aluminum), Chromel (composed of Nickel and Chromium) and Constantan (composed of Copper and Nickel).

COMMON THERMOCOUPLES

JUNCTION MATERIALS	TYPICAL USEFUL RANGE (°C)	NOMINAL SENSITIVITY (μV/°C)	ANSI DESIGNATION
Platinum (6%)/Rhodium-Platinum (30%)/Rhodium	38 to 1800	7.7	B
Tungsten (5%)/Rhenium - Tungsten (26%)/Rhenium	0 to 2300	16	C
Chromel - Constantan	0 to 982	76	E
Iron - Constantan	0 to 760	55	J
Chromel - Alumel	-184 to 1260	39	K
Platinum (13%)/Rhodium-Platinum	0 to 1593	11.7	R
Platinum (10%)/Rhodium-Platinum	0 to 1538	10.4	S
Copper-Constantan	-184 to 400	45	T

Figure 7.3

Figure 7.4 shows the voltage-temperature curves of three commonly used thermocouples, referred to a 0°C fixed-temperature reference junction. Of the thermocouples shown, Type J thermocouples are the most sensitive, producing the largest output voltage for a given temperature change. On the other hand, Type S thermocouples are the least sensitive. These characteristics are very important to consider when designing signal conditioning circuitry in that the thermocouples' relatively low output signals require low-noise, low-drift, high-gain amplifiers.

To understand thermocouple behavior, it is necessary to consider the non-linearities in their response to temperature differences. Figure 7.4 shows the relationships between sensing junction temperature and voltage output for a number of thermocouple types (in all cases, the reference *cold* junction is maintained at 0°C). It is evident that the responses are not quite linear, but the nature of the non-linearity is not so obvious.

Figure 7.5 shows how the Seebeck coefficient (the *change* of output voltage with *change* of sensor junction temperature - i.e., the first derivative of output with respect to temperature) varies with sensor junction temperature (we are still considering the case where the reference junction is maintained at 0°C).

When selecting a thermocouple for making measurements over a particular range of temperature, we should choose a thermocouple whose Seebeck coefficient varies as little as possible over that range.

**THERMOCOUPLE OUTPUT VOLTAGES FOR
TYPE J, K, AND S THERMOCOUPLES**

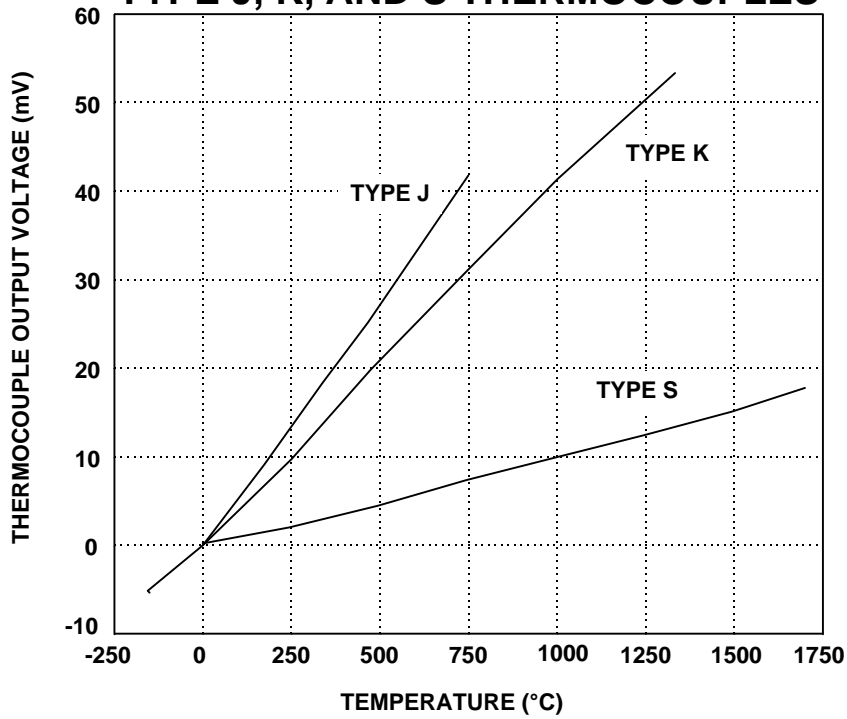

Figure 7.4

**THERMOCOUPLE SEEBECK COEFFICIENT
VERSUS TEMPERATURE**

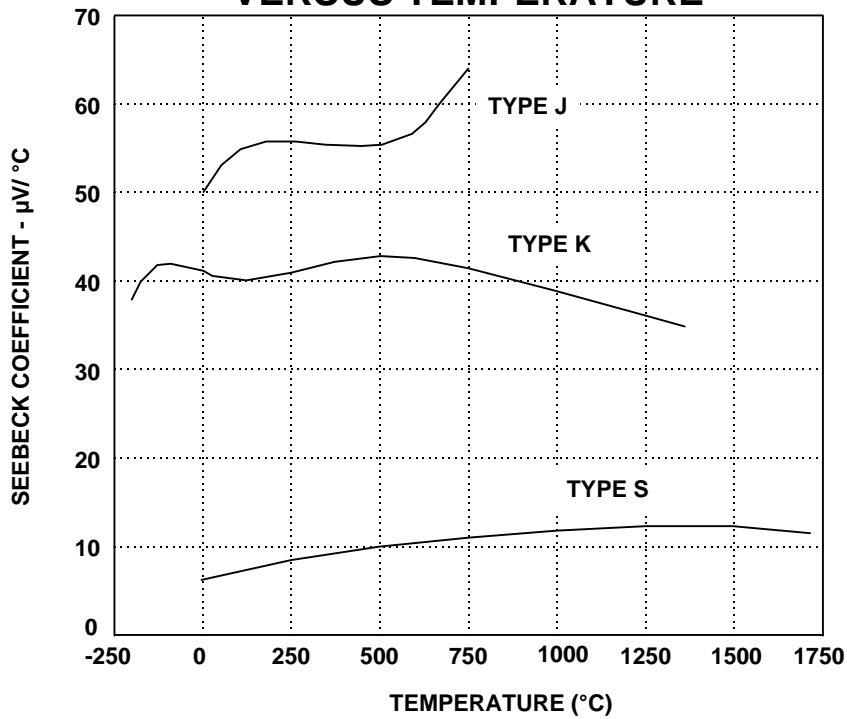

Figure 7.5

For example, a Type J thermocouple has a Seebeck coefficient which varies by less than $1\mu\text{V}/^\circ\text{C}$ between 200 and 500°C , which makes it ideal for measurements in this range.

Presenting these data on thermocouples serves two purposes: First, Figure 7.4 illustrates the range and sensitivity of the three thermocouple types so that the system designer can, at a glance, determine that a Type S thermocouple has the widest useful temperature range, but a Type J thermocouple is more sensitive. Second, the Seebeck coefficients provide a quick guide to a thermocouple's linearity. Using Figure 7.5, the system designer can choose a Type K thermocouple for its linear Seebeck coefficient over the range of 400°C to 800°C or a Type S over the range of 900°C to 1700°C . The behavior of a thermocouple's Seebeck coefficient is important in applications where variations of temperature rather than absolute magnitude are important. These data also indicate what performance is required of the associated signal conditioning circuitry.

To use thermocouples successfully we must understand their basic principles. Consider the diagrams in Figure 7.6.

THERMOCOUPLE BASICS

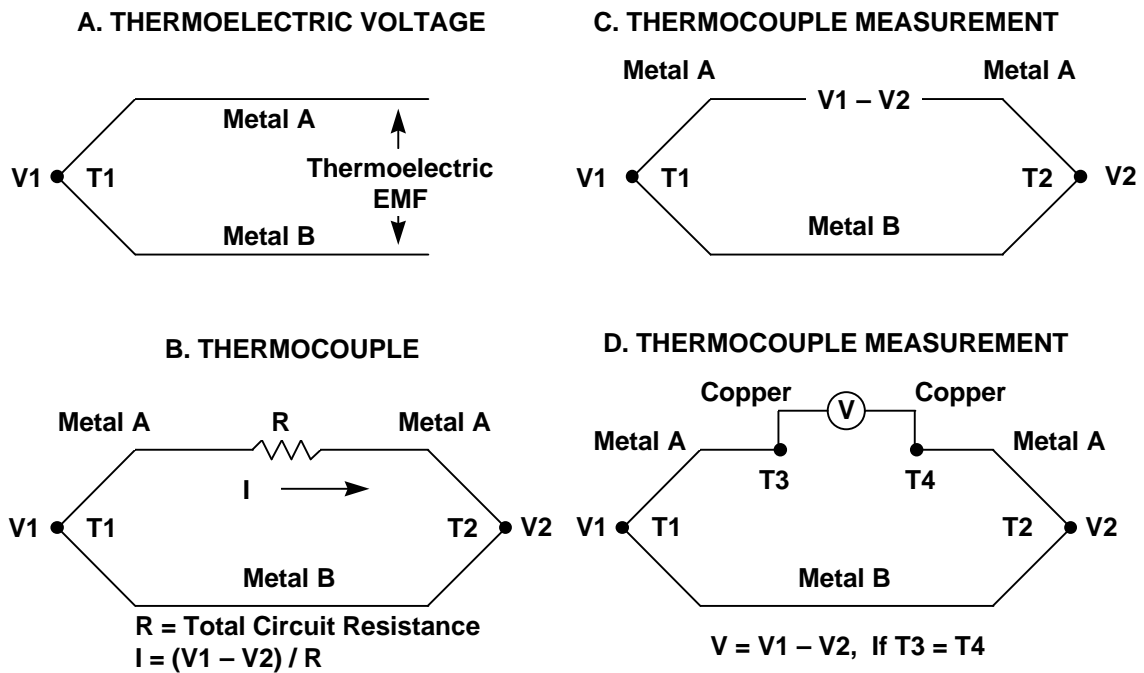

Figure 7.6

If we join two dissimilar metals at any temperature above absolute zero, there will be a potential difference between them (their "thermoelectric e.m.f." or "contact potential") which is a function of the temperature of the junction (Figure 7.6A). If we join the two wires at two places, two junctions are formed (Figure 7.6B). If the two junctions are at different temperatures, there will be a net e.m.f. in the circuit, and a current will flow determined by the e.m.f. and the total resistance in the circuit (Figure 7.6B). If we break one of the wires, the voltage across the break will be

TEMPERATURE SENSORS

equal to the net thermoelectric e.m.f. of the circuit, and if we measure this voltage, we can use it to calculate the temperature difference between the two junctions (Figure 7.6C). *We must always remember that a thermocouple measures the temperature difference between two junctions, not the absolute temperature at one junction.* We can only measure the temperature at the measuring junction if we know the temperature of the other junction (often called the "reference" junction or the "cold" junction).

But it is not so easy to measure the voltage generated by a thermocouple. Suppose that we attach a voltmeter to the circuit in Figure 7.6C (Figure 7.6D). The wires attached to the voltmeter will form further thermojunctions where they are attached. If both these additional junctions are at the same temperature (it does not matter what temperature), then the "Law of Intermediate Metals" states that they will make no net contribution to the total e.m.f. of the system. If they are at different temperatures, they will introduce errors. Since *every pair of dissimilar metals in contact generates a thermoelectric e.m.f.* (including copper/solder, kovar/copper [kovar is the alloy used for IC leadframes] and aluminum/kovar [at the bond inside the IC]), it is obvious that in practical circuits the problem is even more complex, and it is necessary to take extreme care to ensure that all the junction pairs in the circuitry around a thermocouple, except the measurement and reference junctions themselves, are at the same temperature.

Thermocouples generate a voltage, albeit a very small one, and do not require excitation. As shown in Figure 7.6D, however, two junctions (T1, the measurement junction and T2, the reference junction) are involved. If $T_2 = T_1$, then $V_2 = V_1$, and the output voltage $V = 0$. Thermocouple output voltages are often defined with a reference junction temperature of 0°C (hence the term *cold* or *ice point* junction), so the thermocouple provides an output voltage of 0V at 0°C . To maintain system accuracy, the reference junction must therefore be at a well-defined temperature (but not necessarily 0°C). A conceptually simple approach to this need is shown in Figure 7.7. Although an ice/water bath is relatively easy to define, it is quite inconvenient to maintain.

Today an ice-point reference, and its inconvenient ice/water bath, is generally replaced by electronics. A temperature sensor of another sort (often a semiconductor sensor, sometimes a thermistor) measures the temperature of the cold junction and is used to inject a voltage into the thermocouple circuit which compensates for the difference between the actual cold junction temperature and its ideal value (usually 0°C) as shown in Figure 7.8. Ideally, the compensation voltage should be an exact match for the difference voltage required, which is why the diagram gives the voltage as $f(T_2)$ (a *function* of T_2) rather than KT_2 , where K is a simple constant. In practice, since the cold junction is rarely more than a few tens of degrees from 0°C , and generally varies by little more than $\pm 10^\circ\text{C}$, a linear approximation ($V=KT_2$) to the more complex reality is sufficiently accurate and is what is often used. (The expression for the output voltage of a thermocouple with its measuring junction at $T^\circ\text{C}$ and its reference at 0°C is a polynomial of the form $V = K_1T + K_2T^2 + K_3T^3 + \dots$, but the values of the coefficients K_2 , K_3 , etc. are very small for most common types of thermocouple. References 8 and 9 give the values of these coefficients for a wide range of thermocouples.)

CLASSICAL COLD-JUNCTION COMPENSATION USING AN ICE-POINT (0°C) REFERENCE JUNCTION

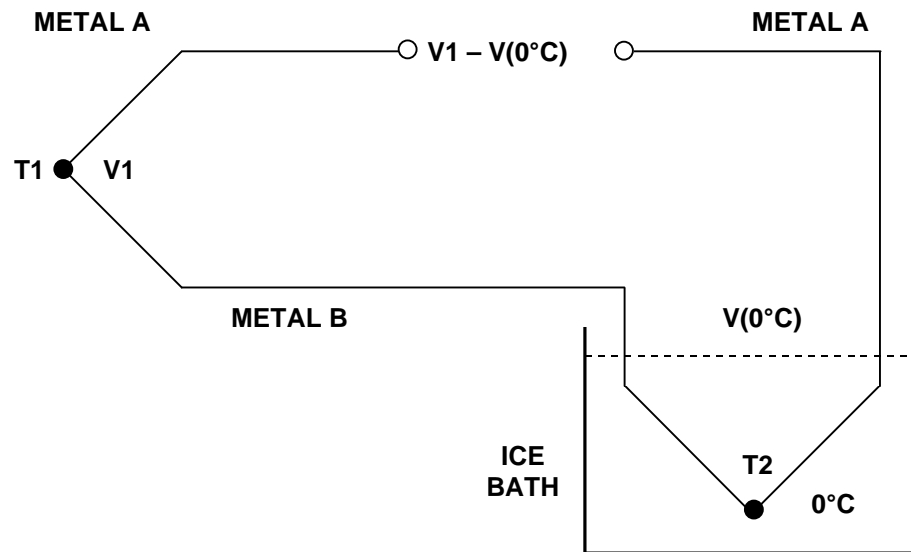
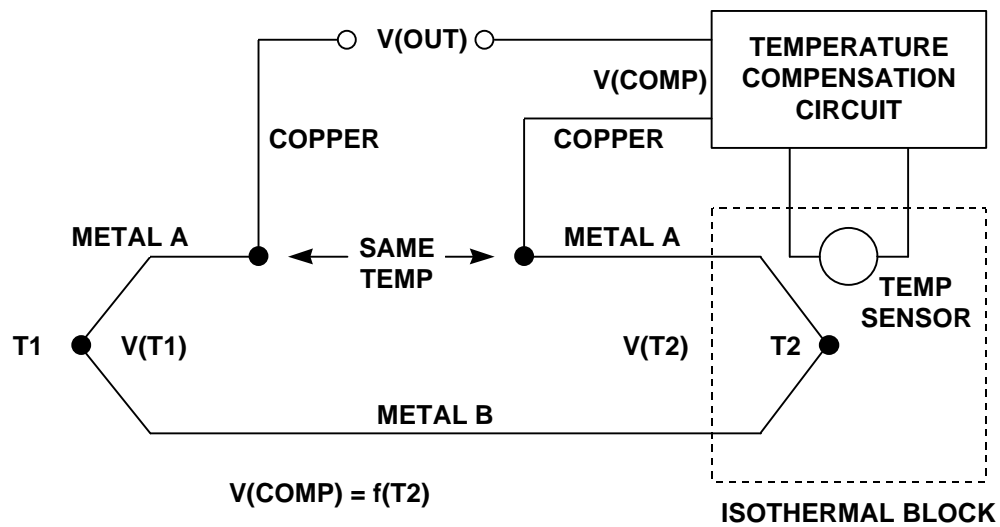

Figure 7.7

USING A TEMPERATURE SENSOR FOR COLD-JUNCTION COMPENSATION



$$V(\text{COMP}) = f(T_2)$$

$$V(\text{OUT}) = V(T_1) - V(T_2) + V(\text{COMP})$$

IF $V(\text{COMP}) = V(T_2) - V(0^\circ\text{C})$, THEN

$$V(\text{OUT}) = V(T_1) - V(0^\circ\text{C})$$

Figure 7.8

TEMPERATURE SENSORS

When electronic cold-junction compensation is used, it is common practice to eliminate the additional thermocouple wire and terminate the thermocouple leads in the isothermal block in the arrangement shown in Figure 7.9. The Metal A-Copper and the Metal B-Copper junctions, if at the same temperature, are equivalent to the Metal A-Metal B thermocouple junction in Figure 7.8.

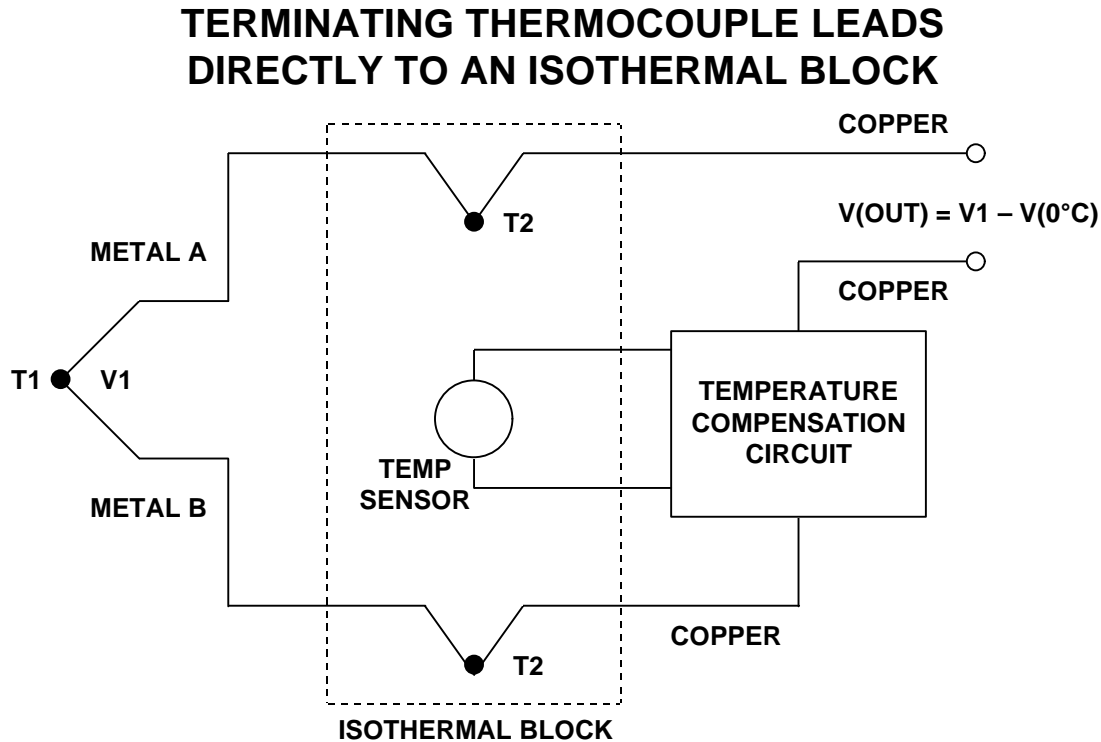

Figure 7.9

The circuit in Figure 7.10 conditions the output of a Type K thermocouple, while providing cold-junction compensation, for temperatures between 0°C and 250°C. The circuit operates from single +3.3V to +12V supplies and has been designed to produce an output voltage transfer characteristic of 10mV/°C.

A Type K thermocouple exhibits a Seebeck coefficient of approximately 41μV/°C; therefore, at the cold junction, the TMP35 voltage output sensor with a temperature coefficient of 10mV/°C is used with R1 and R2 to introduce an opposing cold-junction temperature coefficient of -41μV/°C. This prevents the isothermal, cold-junction connection between the circuit's printed circuit board traces and the thermocouple's wires from introducing an error in the measured temperature. This compensation works extremely well for circuit ambient temperatures in the range of 20°C to 50°C. Over a 250°C measurement temperature range, the thermocouple produces an output voltage change of 10.151mV. Since the required circuit's output full-scale voltage change is 2.5V, the gain of the circuit is set to 246.3. Choosing R4 equal to 4.99kΩ sets R5 equal to 1.22MΩ. Since the closest 1% value for R5 is 1.21MΩ, a 50kΩ potentiometer is used with R5 for fine trim of the full-scale output voltage. Although the OP193 is a single-supply op amp, its output stage is not rail-to-rail, and will only go down to about 0.1V above ground. For this reason, R3 is added to the circuit to supply an output offset voltage of about 0.1V for a nominal supply voltage of 5V. This offset (10°C) must be subtracted when making measurements

referenced to the OP193 output. R3 also provides an open thermocouple detection, forcing the output voltage to greater than 3V should the thermocouple open. Resistor R7 balances the DC input impedance of the OP193, and the 0.1μF film capacitor reduces noise coupling into its non-inverting input.

USING A TEMPERATURE SENSOR FOR COLD-JUNCTION COMPENSATION (TMP35)

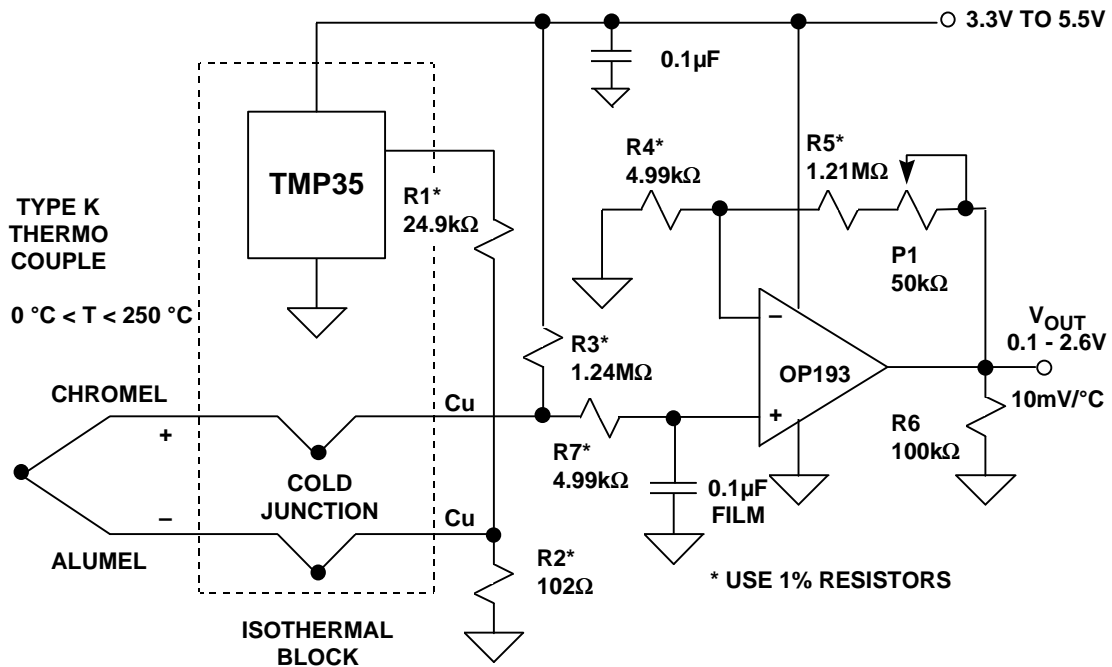

Figure 7.10

The AD594/AD595 is a complete instrumentation amplifier and thermocouple cold junction compensator on a monolithic chip (see Figure 7.11). It combines an ice point reference with a precalibrated amplifier to provide a high level (10mV/°C) output directly from the thermocouple signal. Pin-strapping options allow it to be used as a linear amplifier-compensator or as a switched output set-point controller using either fixed or remote set-point control. It can be used to amplify its compensation voltage directly, thereby becoming a stand-alone Celsius transducer with 10mV/°C output. In such applications it is very important that the IC chip is at the same temperature as the cold junction of the thermocouple, which is usually achieved by keeping the two in close proximity and isolated from any heat sources.

The AD594/AD595 includes a thermocouple failure alarm that indicates if one or both thermocouple leads open. The alarm output has a flexible format which includes TTL drive capability. The device can be powered from a single-ended supply (which may be as low as +5V), but by including a negative supply, temperatures below 0°C can be measured. To minimize self-heating, an unloaded AD594/AD595 will operate with a supply current of 160μA, but is also capable of delivering ±5mA to a load.

The AD594 is precalibrated by laser wafer trimming to match the characteristics of type J (iron/constantan) thermocouples, and the AD595 is laser trimmed for type K

TEMPERATURE SENSORS

(chromel/alumel). The temperature transducer voltages and gain control resistors are available at the package pins so that the circuit can be recalibrated for other thermocouple types by the addition of resistors. These terminals also allow more precise calibration for both thermocouple and thermometer applications. The AD594/AD595 is available in two performance grades. The C and the A versions have calibration accuracies of $\pm 1^\circ\text{C}$ and $\pm 3^\circ\text{C}$, respectively. Both are designed to be used with cold junctions between 0 to $+50^\circ\text{C}$. The circuit shown in Figure 7.11 will provide a direct output from a type J thermocouple (AD594) or a type K thermocouple (AD595) capable of measuring 0 to $+300^\circ\text{C}$.

AD594/AD595 MONOLITHIC THERMOCOUPLE AMPLIFIERS WITH COLD-JUNCTION COMPENSATION

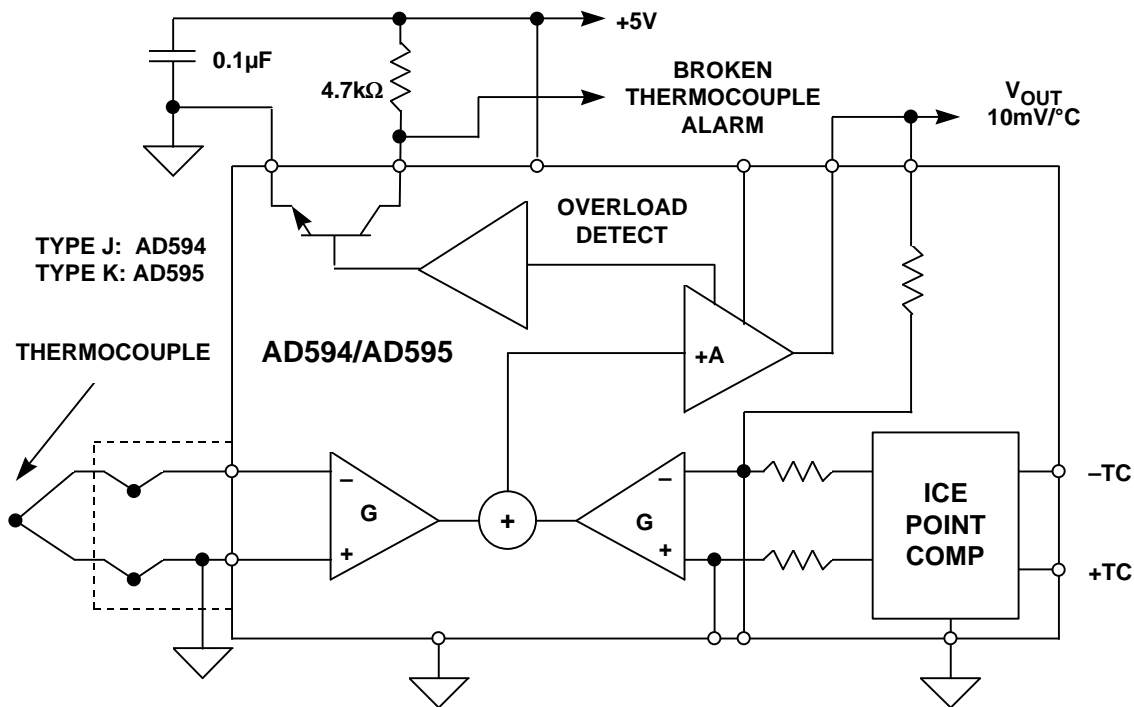

Figure 7.11

The AD596/AD597 are monolithic set-point controllers which have been optimized for use at elevated temperatures as are found in oven control applications. The device cold-junction compensates and amplifies a type J/K thermocouple to derive an internal signal proportional to temperature. They can be configured to provide a voltage output ($10\text{mV}/^\circ\text{C}$) directly from type J/K thermocouple signals. The device is packaged in a 10-pin metal can and is trimmed to operate over an ambient range from $+25^\circ\text{C}$ to $+100^\circ\text{C}$. The AD596 will amplify thermocouple signals covering the entire -200°C to $+760^\circ\text{C}$ temperature range recommended for type J thermocouples while the AD597 can accommodate -200°C to $+1250^\circ\text{C}$ type K inputs. They have a calibration accuracy of $\pm 4^\circ\text{C}$ at an ambient temperature of 60°C and an ambient temperature stability specification of $0.05^\circ\text{C}/^\circ\text{C}$ from $+25^\circ\text{C}$ to $+100^\circ\text{C}$.

None of the thermocouple amplifiers previously described compensate for thermocouple non-linearity, they only provide conditioning and voltage gain. High

resolution ADCs such as the AD77XX family can be used to digitize the thermocouple output directly, allowing a microcontroller to perform the transfer function linearization as shown in Figure 7.12. The two multiplexed inputs to the ADC are used to digitize the thermocouple voltage and the cold-junction temperature sensor outputs directly. The input PGA gain is programmable from 1 to 128, and the ADC resolution is between 16 and 22 bits (depending upon the particular ADC selected). The microcontroller performs both the cold-junction compensation and the linearization arithmetic.

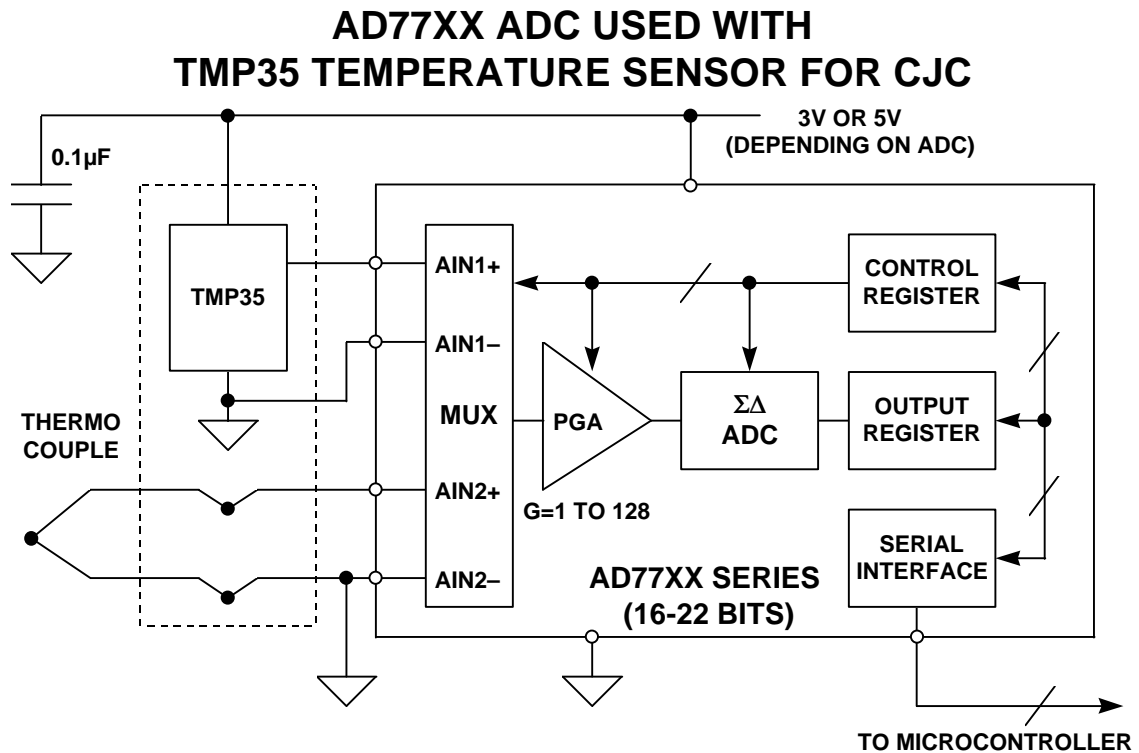

Figure 7.12

RESISTANCE TEMPERATURE DETECTORS (RTDs)

The Resistance Temperature Detector, or the RTD, is a sensor whose resistance changes with temperature. Typically built of a platinum (Pt) wire wrapped around a ceramic bobbin, the RTD exhibits behavior which is more accurate and more linear over wide temperature ranges than a thermocouple. Figure 7.13 illustrates the temperature coefficient of a 100Ω RTD and the Seebeck coefficient of a Type S thermocouple. Over the entire range (approximately -200°C to $+850^{\circ}\text{C}$), the RTD is a more linear device. Hence, linearizing an RTD is less complex.

RESISTANCE TEMPERATURE DETECTORs (RTD)

- Platinum (Pt) the Most Common
- 100Ω, 1000Ω Standard Values
- Typical TC = 0.385% / °C,
0.385Ω / °C for 100Ω Pt RTD
- Good Linearity - Better than Thermocouple,
Easily Compensated

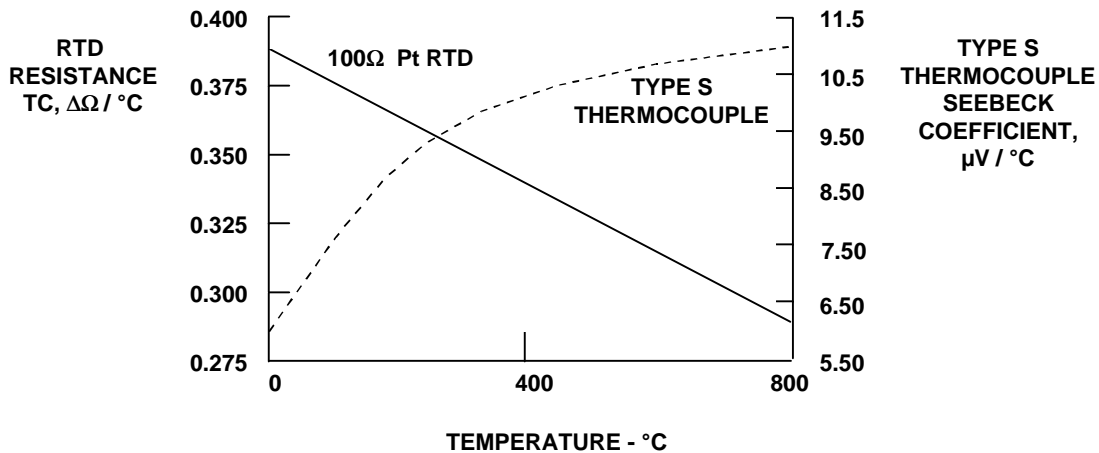

Figure 7.13

Unlike a thermocouple, however, an RTD is a passive sensor and requires current excitation to produce an output voltage. The RTD's low temperature coefficient of 0.385%/°C requires similar high-performance signal conditioning circuitry to that used by a thermocouple; however, the voltage drop across an RTD is much larger than a thermocouple output voltage. A system designer may opt for large value RTDs with higher output, but large-valued RTDs exhibit slow response times. Furthermore, although the cost of RTDs is higher than that of thermocouples, they use copper leads, and thermoelectric effects from terminating junctions do not affect their accuracy. And finally, because their resistance is a function of the absolute temperature, RTDs require no cold-junction compensation.

Caution must be exercised using current excitation because the current through the RTD causes heating. This self-heating changes the temperature of the RTD and appears as a measurement error. Hence, careful attention must be paid to the design of the signal conditioning circuitry so that self-heating is kept below 0.5°C. Manufacturers specify self-heating errors for various RTD values and sizes in still and in moving air. To reduce the error due to self-heating, the minimum current should be used for the required system resolution, and the largest RTD value chosen that results in acceptable response time.

Another effect that can produce measurement error is voltage drop in RTD lead wires. This is especially critical with low-value 2-wire RTDs because the temperature coefficient and the absolute value of the RTD resistance are both small. If the RTD is located a long distance from the signal conditioning circuitry, then the lead resistance can be ohms or tens of ohms, and a small amount of lead resistance can contribute a significant error to the temperature measurement. To illustrate

this point, let us assume that a 100Ω platinum RTD with 30-gauge copper leads is located about 100 feet from a controller's display console. The resistance of 30-gauge copper wire is $0.105\Omega/\text{ft}$, and the two leads of the RTD will contribute a total 21Ω to the network which is shown in Figure 7.14. This additional resistance will produce a 55°C error in the measurement! The leads' temperature coefficient can contribute an additional, and possibly significant, error to the measurement. To eliminate the effect of the lead resistance, a 4-wire technique is used.

A 100Ω Pt RTD WITH 100 FEET OF 30-GAUGE LEAD WIRES

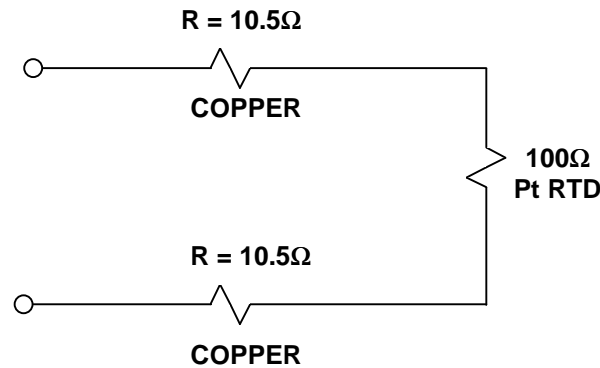

RESISTANCE TC OF COPPER = $0.40\%/^\circ\text{C}$ @ 20°C

RESISTANCE TC OF Pt RTD = $0.385\%/^\circ\text{C}$ @ 20°C

Figure 7.14

In Figure 7.15, a 4-wire, or Kelvin, connection is made to the RTD. A constant current is applied through the FORCE leads of the RTD, and the voltage across the RTD itself is measured remotely via the SENSE leads. The measuring device can be a DVM or an instrumentation amplifier, and high accuracy can be achieved provided that the measuring device exhibits high input impedance and/or low input bias current. Since the SENSE leads do not carry appreciable current, this technique is insensitive to lead wire length. Sources of errors are the stability of the constant current source and the input impedance and/or bias currents in the amplifier or DVM.

RTDs are generally configured in a four-resistor bridge circuit. The bridge output is amplified by an instrumentation amplifier for further processing. However, high resolution measurement ADCs such as the AD77XX series allow the RTD output to be digitized directly. In this manner, linearization can be performed digitally, thereby easing the analog circuit requirements.

FOUR-WIRE OR KELVIN CONNECTION TO Pt RTD FOR ACCURATE MEASUREMENTS

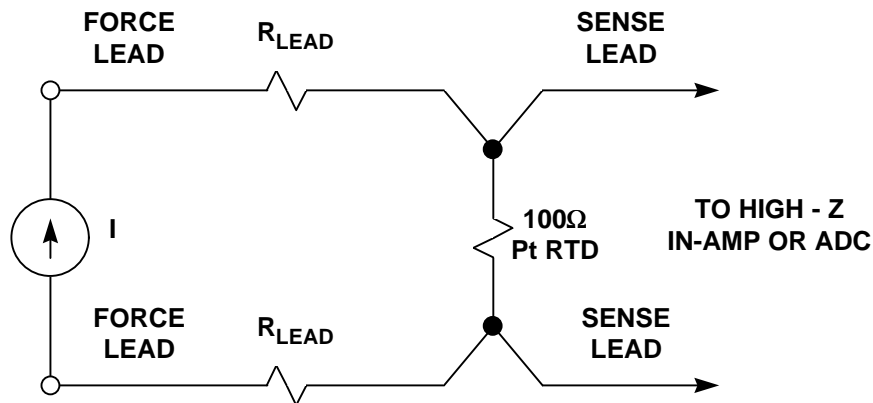

Figure 7.15

Figure 7.16 shows a 100Ω Pt RTD driven with a 400μA excitation current source. The output is digitized by one of the AD77XX series ADCs. Note that the RTD excitation current source also generates the 2.5V reference voltage for the ADC via the 6.25kΩ resistor. Variations in the excitation current do not affect the circuit accuracy, since both the input voltage and the reference voltage vary ratiometrically with the excitation current. However, the 6.25kΩ resistor must have a low temperature coefficient to avoid errors in the measurement. The high resolution of the ADC and the input PGA (gain of 1 to 128) eliminates the need for additional conditioning circuits.

The ADT70 is a complete Pt RTD signal conditioner which provides an output voltage of 5mV/°C when using a 1kΩ RTD (see Figure 7.17). The Pt RTD and the 1kΩ reference resistor are both excited with 1mA matched current sources. This allows temperature measurements to be made over a range of approximately -50°C to +800°C.

The ADT70 contains the two matched current sources, a precision rail-to-rail output instrumentation amplifier, a 2.5V reference, and an uncommitted rail-to-rail output op amp. The ADT71 is the same as the ADT70 except the internal voltage reference is omitted. A shutdown function is included for battery powered equipment that reduces the quiescent current from 3mA to 10μA. The gain or full-scale range for the Pt RTD and ADT701 system is set by a precision external resistor connected to the instrumentation amplifier. The uncommitted op amp may be used for scaling the internal voltage reference, providing a "Pt RTD open" signal or "over temperature" warning, providing a heater switching signal, or other external conditioning determined by the user. The ADT70 is specified for operation from -40°C to +125°C and is available in 20-pin DIP and SOIC packages.

INTERFACING A Pt RTD TO A HIGH RESOLUTION ADC

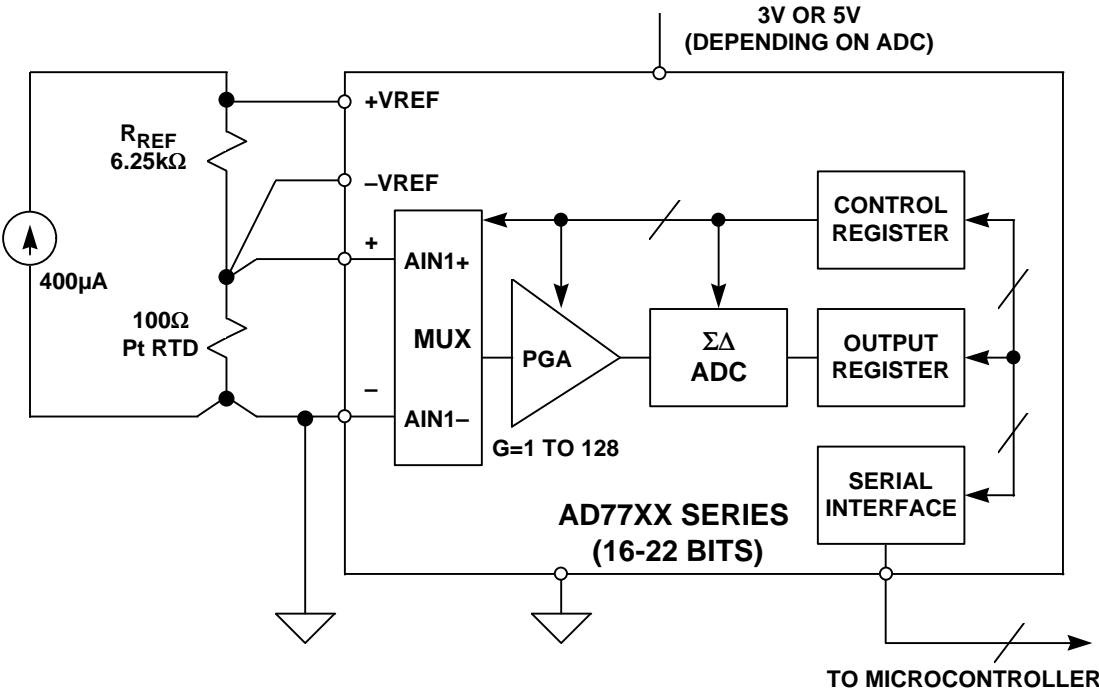

Figure 7.16

CONDITIONING THE PLATINUM RTD USING THE ADT70

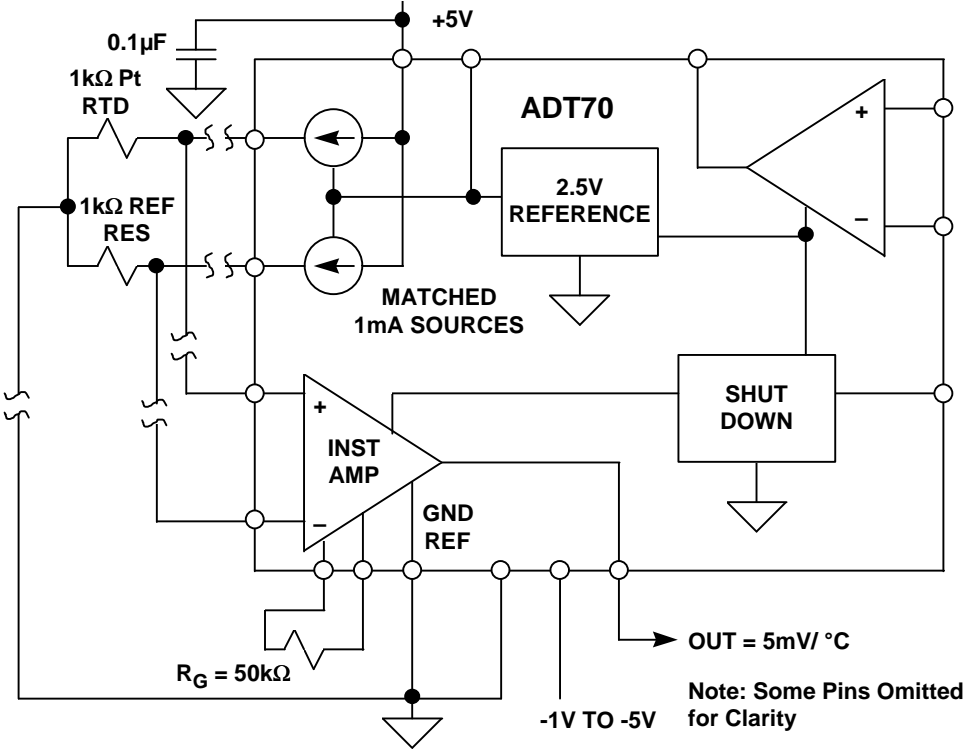

Figure 7.17

THERMISTORS

Similar in function to the RTD, thermistors are low-cost temperature-sensitive resistors and are constructed of solid semiconductor materials which exhibit a positive or negative temperature coefficient. Although positive temperature coefficient devices are available, the most commonly used thermistors are those with a negative temperature coefficient. Figure 7.18 shows the resistance-temperature characteristic of a commonly used NTC (Negative Temperature Coefficient) thermistor. The thermistor is highly non-linear and, of the three temperature sensors discussed, is the most sensitive.

RESISTANCE CHARACTERISTICS OF A 10k Ω NTC THERMISTOR

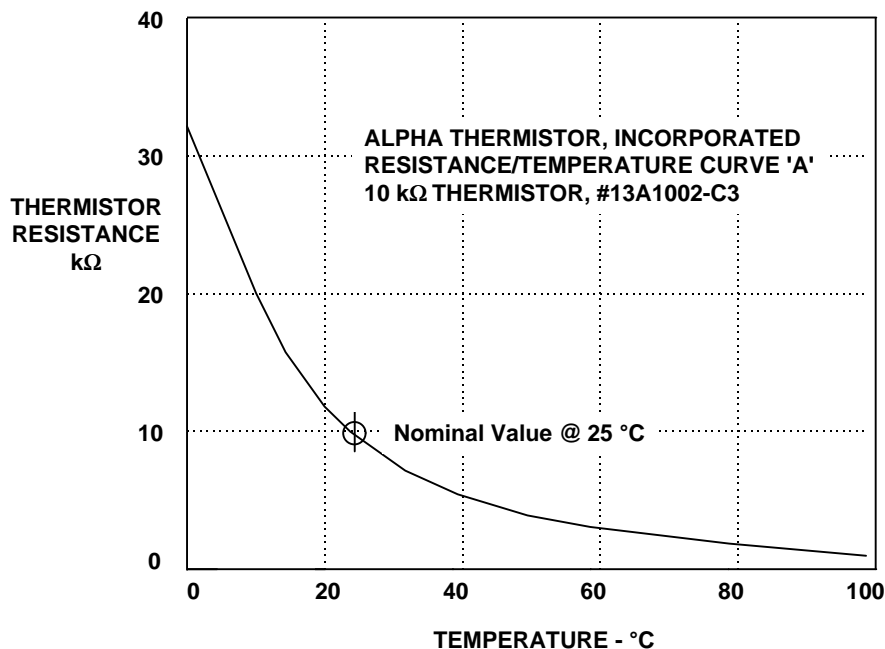

Figure 7.18

The thermistor's high sensitivity (typically, $-44,000\text{ppm}/^{\circ}C$ at $25^{\circ}C$, as shown in Figure 7.19), allows it to detect minute variations in temperature which could not be observed with an RTD or thermocouple. This high sensitivity is a distinct advantage over the RTD in that 4-wire Kelvin connections to the thermistor are not needed to compensate for lead wire errors. To illustrate this point, suppose a $10k\Omega$ NTC thermistor, with a typical $25^{\circ}C$ temperature coefficient of $-44,000\text{ppm}/^{\circ}C$, were substituted for the 100Ω Pt RTD in the example given earlier, then a total lead wire resistance of 21Ω would generate less than $0.05^{\circ}C$ error in the measurement. This is roughly a factor of 500 improvement in error over an RTD.

TEMPERATURE COEFFICIENT OF 10k Ω NTC THERMISTOR

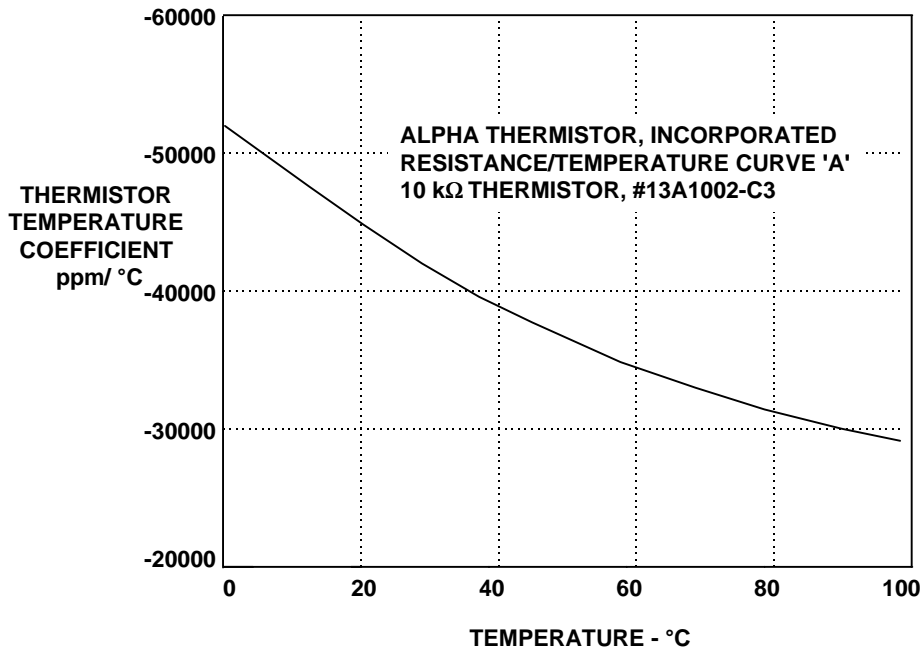

Figure 7.19

However, the thermistor's high sensitivity to temperature does not come without a price. As was shown in Figure 7.18, the temperature coefficient of thermistors does not decrease linearly with increasing temperature as it does with RTDs; therefore, linearization is required for all but the narrowest of temperature ranges. Thermistor applications are limited to a few hundred degrees at best because they are more susceptible to damage at high temperatures. Compared to thermocouples and RTDs, thermistors are fragile in construction and require careful mounting procedures to prevent crushing or bond separation. Although a thermistor's response time is short due to its small size, its small thermal mass makes it very sensitive to self-heating errors.

Thermistors are very inexpensive, highly sensitive temperature sensors. However, we have shown that a thermistor's temperature coefficient varies from $-44,000$ ppm/°C at 25°C to $-29,000$ ppm/°C at 100°C. Not only is this non-linearity the largest source of error in a temperature measurement, it also limits useful applications to very narrow temperature ranges if linearization techniques are not used.

It is possible to use a thermistor over a wide temperature range only if the system designer can tolerate a lower sensitivity to achieve improved linearity. One approach to linearizing a thermistor is simply shunting it with a fixed resistor. Paralleling the thermistor with a fixed resistor increases the linearity significantly. As shown in Figure 7.20, the parallel combination exhibits a more linear variation with temperature compared to the thermistor itself. Also, the sensitivity of the combination still is high compared to a thermocouple or RTD. The primary

TEMPERATURE SENSORS

disadvantage to this technique is that linearization can only be achieved within a narrow range.

LINEARIZATION OF NTC THERMISTOR USING A 5.17kΩ SHUNT RESISTOR

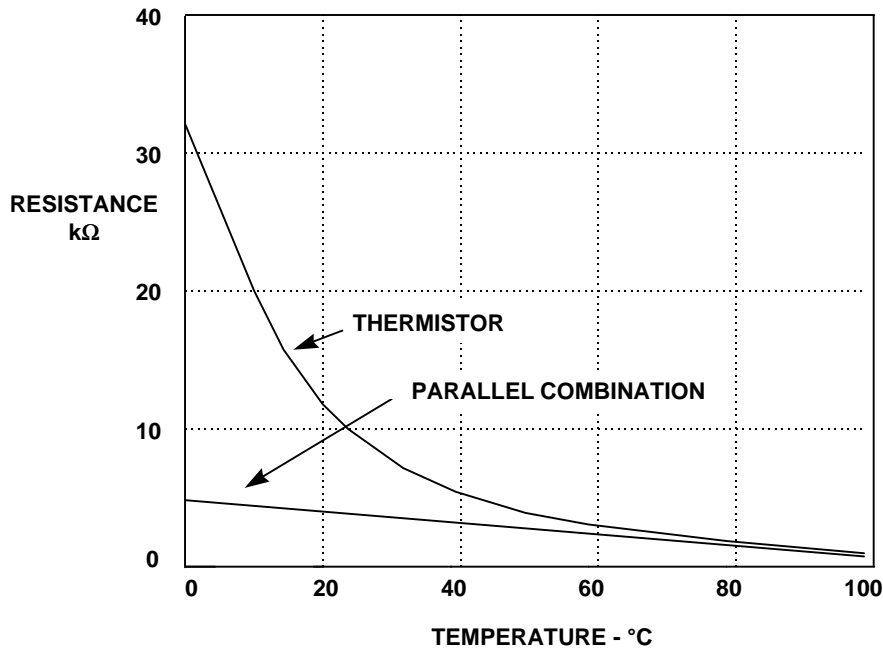

Figure 7.20

The value of the fixed resistor can be calculated from the following equation:

$$R = \frac{RT_2 \cdot (RT_1 + RT_3) - 2 \cdot RT_1 \cdot RT_3}{RT_1 + RT_3 - 2 \cdot RT_2},$$

where RT_1 is the thermistor resistance at T_1 , the lowest temperature in the measurement range, RT_3 is the thermistor resistance at T_3 , the highest temperature in the range, and RT_2 is the thermistor resistance at T_2 , the midpoint, $T_2 = (T_1 + T_3)/2$.

For a typical 10kΩ NTC thermistor, $RT_1 = 32,650\Omega$ at 0°C , $RT_2 = 6,532\Omega$ at 35°C , and $RT_3 = 1,752\Omega$ at 70°C . This results in a value of 5.17kΩ for R . The accuracy needed in the signal conditioning circuitry depends on the linearity of the network. For the example given above, the network shows a non-linearity of $-2.3^\circ\text{C}/+2.0^\circ\text{C}$.

The output of the network can be applied to an ADC to perform further linearization as shown in Figure 7.21. Note that the output of the thermistor network has a slope of approximately $-10\text{mV}/^\circ\text{C}$, which implies a 12-bit ADC has more than sufficient resolution.

LINEARIZED THERMISTOR AMPLIFIER

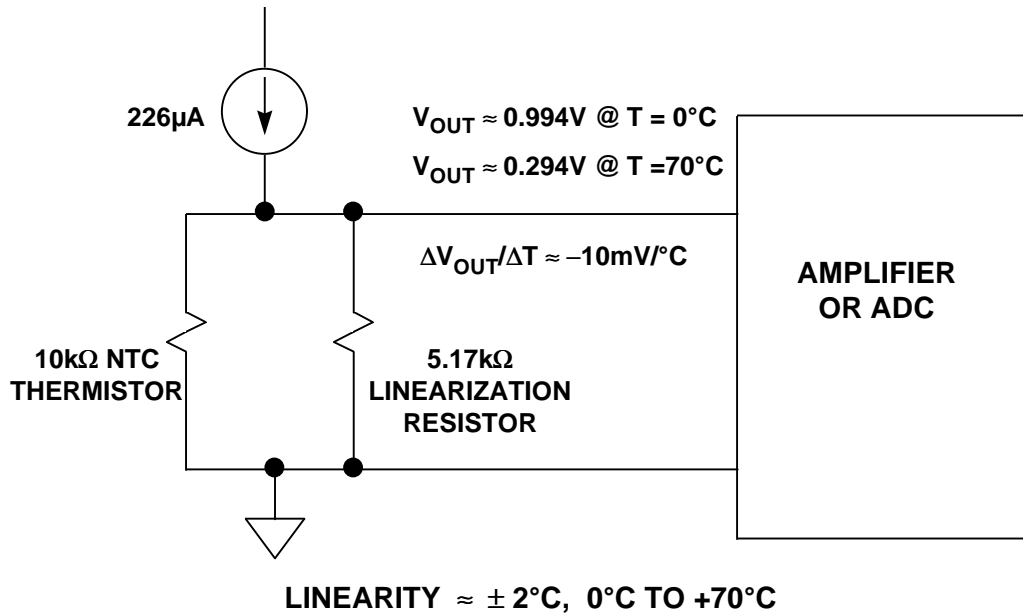

Figure 7.21

SEMICONDUCTOR TEMPERATURE SENSORS

Modern semiconductor temperature sensors offer high accuracy and high linearity over an operating range of about $-55^{\circ}C$ to $+150^{\circ}C$. Internal amplifiers can scale the output to convenient values, such as $10mV/^{\circ}C$. They are also useful in cold-junction-compensation circuits for wide temperature range thermocouples.

All semiconductor temperature sensors make use of the relationship between a bipolar junction transistor's (BJT) base-emitter voltage to its collector current:

$$V_{BE} = \frac{kT}{q} \ln\left(\frac{I_C}{I_S}\right)$$

where k is Boltzmann's constant, T is the absolute temperature, q is the charge of an electron, and I_S is a current related to the geometry and the temperature of the transistors. (The equation assumes a voltage of at least a few hundred mV on the collector, and ignores Early effects.)

If we take N transistors identical to the first (see Figure 7.22) and allow the total current I_C to be shared equally among them, we find that the new base-emitter voltage is given by the equation

$$V_N = \frac{kT}{q} \ln\left(\frac{I_C}{N \cdot I_S}\right)$$

BASIC RELATIONSHIPS FOR SEMICONDUCTOR TEMPERATURE SENSORS

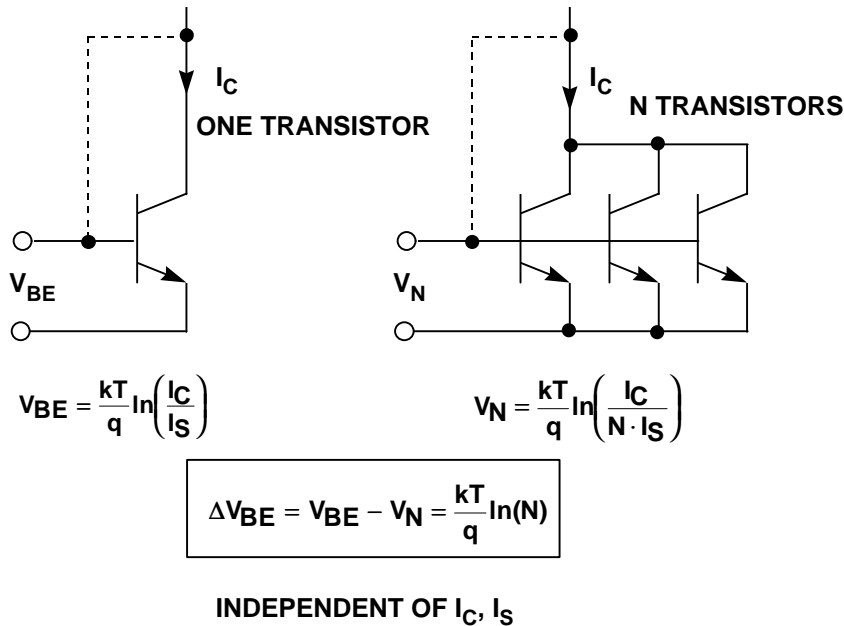

Figure 7.22

Neither of these circuits is of much use by itself because of the strongly temperature dependent current I_S , but if we have equal currents in one BJT and N similar BJTs then the expression for the *difference* between the two base-emitter voltages is proportional to absolute temperature and does not contain I_S .

$$\Delta V_{BE} = V_{BE} - V_N = \frac{kT}{q} \ln\left(\frac{I_C}{I_S}\right) - \frac{kT}{q} \ln\left(\frac{I_C}{N \cdot I_S}\right)$$

$$\Delta V_{BE} = V_{BE} - V_N = \frac{kT}{q} \left[\ln\left(\frac{I_C}{I_S}\right) - \ln\left(\frac{I_C}{N \cdot I_S}\right) \right]$$

$$\Delta V_{BE} = V_{BE} - V_N = \frac{kT}{q} \ln \left[\frac{\left(\frac{I_C}{I_S}\right)}{\left(\frac{I_C}{N \cdot I_S}\right)} \right] = \frac{kT}{q} \ln(N)$$

The circuit shown in Figure 7.23 implements the above equation and is known as the "Brokaw Cell" (see Reference 10). The voltage $\Delta V_{BE} = V_{BE} - V_N$ appears across resistor R_2 . The emitter current in Q_2 is therefore $\Delta V_{BE}/R_2$. The op amp's servo loop and the resistors, R , force the same current to flow through Q_1 . The Q_1 and Q_2 currents are equal and are summed and flow into resistor R_1 . The corresponding voltage developed across R_1 is proportional to absolute temperature (PTAT) and given by:

$$V_{PTAT} = \frac{2R_1(V_{BE} - V_N)}{R_2} = 2 \frac{R_1}{R_2} \frac{kT}{q} \ln(N).$$

CLASSIC BANDGAP TEMPERATURE SENSOR

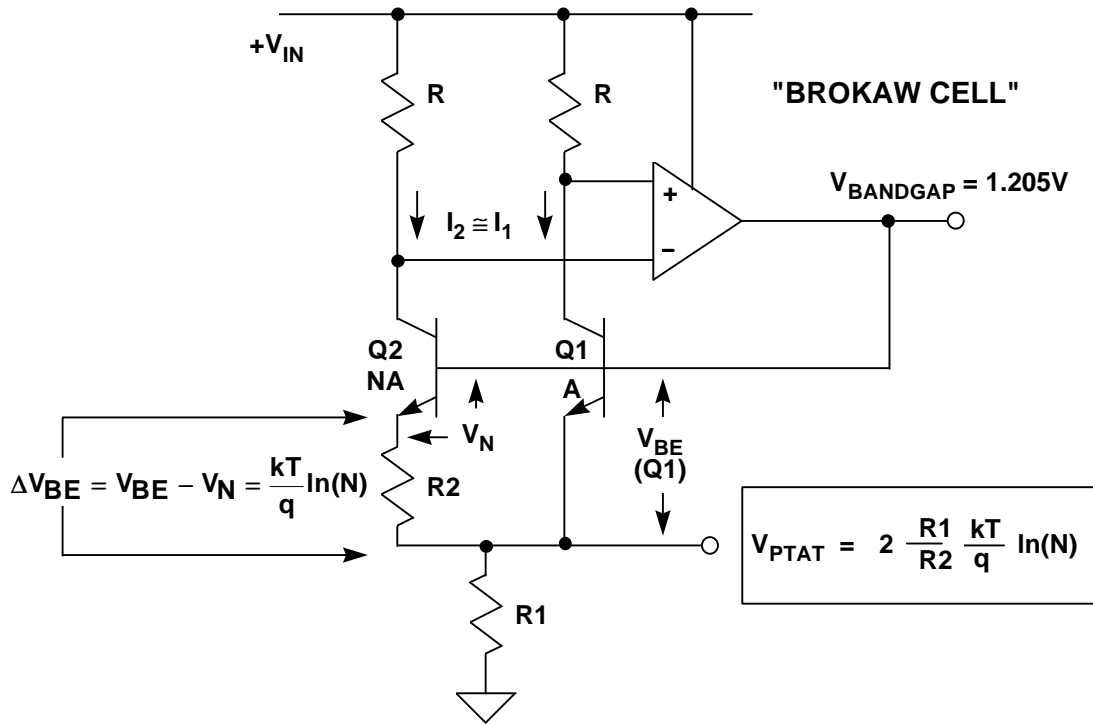

Figure 7.23

The bandgap cell reference voltage, $V_{BANDGAP}$, appears at the base of Q1 and is the sum of $V_{BE}(Q1)$ and V_{PTAT} . $V_{BE}(Q1)$ is complementary to absolute temperature (CTAT), and summing it with V_{PTAT} causes the bandgap voltage to be constant with respect to temperature (assuming proper choice of $R1/R2$ ratio and N to make the bandgap voltage equal to 1.205V). This circuit is the basic *band-gap* temperature sensor, and is widely used in semiconductor temperature sensors.

Current and Voltage Output Temperature Sensors

The concepts used in the bandgap temperature sensor discussion above can be used as the basis for a variety of IC temperature sensors to generate either current or voltage outputs. The AD592 and TMP17 (see Figure 7.24) are current output sensors which have scale factors of $1\mu A/K$. The sensors do not require external calibration and are available in several accuracy grades. The AD592 is available in three accuracy grades. The highest grade version (AD592CN) has a maximum error @ 25°C of $\pm 0.5^\circ C$ and $\pm 1.0^\circ C$ error from $-25^\circ C$ to $+105^\circ C$. Linearity error is $\pm 0.35^\circ C$. The TMP17 is available in two accuracy grades. The highest grade version (TMP17F) has a maximum error @ 25°C of $\pm 2.5^\circ C$ and $\pm 3.5^\circ C$ error from $-40^\circ C$ to $+105^\circ C$. Typical linearity error is $\pm 0.5^\circ C$. The AD592 is available in a TO-92 package and the TMP17 in an SO-8 package.

CURRENT OUTPUT SENSORS: AD592, TMP17

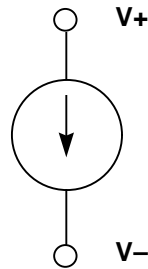

AD592: TO-92 PACKAGE

TMP17: SO-8 PACKAGE

- 1μA/K Scale Factor
- Nominal Output Current @ +25°C: 298.2μA
- Operation from 4V to 30V
- ±0.5°C Max Error @ 25°C, ±1.0°C Error Over Temp, ±0.1°C Typical Nonlinearity (AD592CN)
- ±2.5°C Max Error @ 25°C, ±3.5°C Error Over Temp, ±0.5°C Typical Nonlinearity (TMP17F)
- AD592 Specified from -25°C to +105°C
- TMP17 Specified from -40°C to +105°C

Figure 7.24

RATIOMETRIC VOLTAGE OUTPUT SENSORS

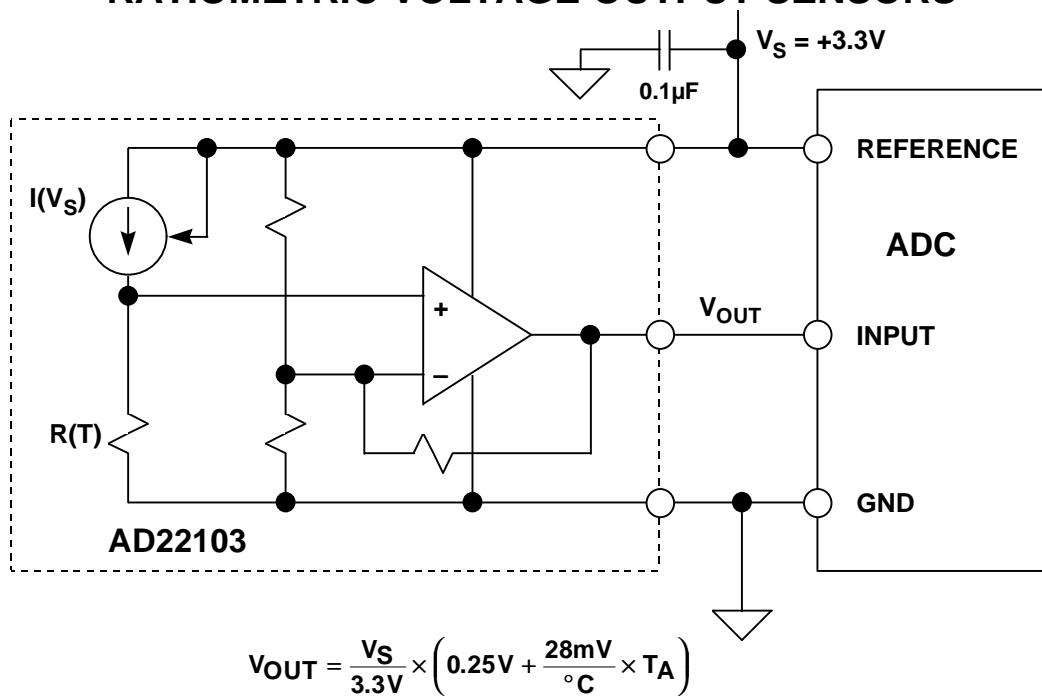

Figure 7.25

In some cases, it is desirable for the output of a temperature sensor to be ratiometric with its supply voltage. The AD22103 (see Figure 7.25) has an output that is ratiometric with its supply voltage (nominally 3.3V) according to the equation:

$$V_{OUT} = \frac{V_S}{3.3V} \times \left(0.25V + \frac{28mV}{^{\circ}C} \times T_A \right).$$

The circuit shown in Figure 7.25 uses the AD22103 power supply as the reference to the ADC, thereby eliminating the need for a precision voltage reference. The AD22103 is specified over a range of 0°C to +100°C and has an accuracy better than ±2.5°C and a linearity better than ±0.5°C.

The TMP35/TMP36/TMP37 are low voltage (2.7V to 5.5V) SOT-23 (5-pin), SO-8, or TO-92 packaged voltage output temperature sensors with a 10mV/°C (TMP35/36) or 20mV/°C (TMP37) scale factor (see Figure 7.26). Supply current is below 50µA, providing very low self-heating (less than 0.1°C in still air). A shutdown feature is provided which reduces the current to 0.5µA.

The TMP35 provides a 250mV output at +25°C and reads temperature from +10°C to +125°C. The TMP36 is specified from -40°C to +125°C. and provides a 750mV output at 25°C. Both the TMP35 and TMP36 have an output scale factor of +10mV/°C. The TMP37 is intended for applications over the range +5°C to +100°C, and provides an output scale factor of 20mV/°C. The TMP37 provides a 500mV output at +25°C.

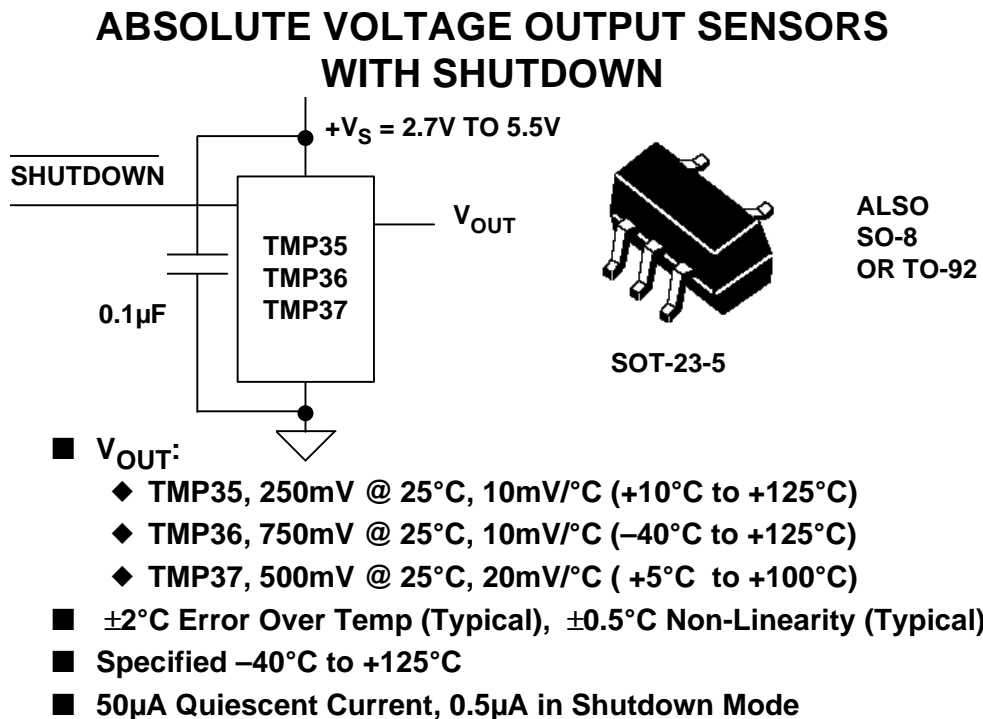

Figure 7.26

TEMPERATURE SENSORS

The ADT45/ADT50 are voltage output temperature sensors packaged in a SOT-23-3 package designed for an operating voltage of 2.7V to 12V (see Figure 7.27). The devices are specified over the range of -40°C to $+125^{\circ}\text{C}$. The output scale factor for both devices is $10\text{mV}/^{\circ}\text{C}$. Typical accuracies are $\pm 1^{\circ}\text{C}$ at $+25^{\circ}\text{C}$ and $\pm 2^{\circ}\text{C}$ over the -40°C to $+125^{\circ}\text{C}$ range. The ADT45 provides a 250mV output at $+25^{\circ}\text{C}$ and is specified for temperature from 0°C to $+100^{\circ}\text{C}$. The ADT50 provides a 750mV output at $+25^{\circ}\text{C}$ and is specified for temperature from -40°C to $+125^{\circ}\text{C}$.

ADT45/ADT50 ABSOLUTE VOLTAGE OUTPUT SENSORS

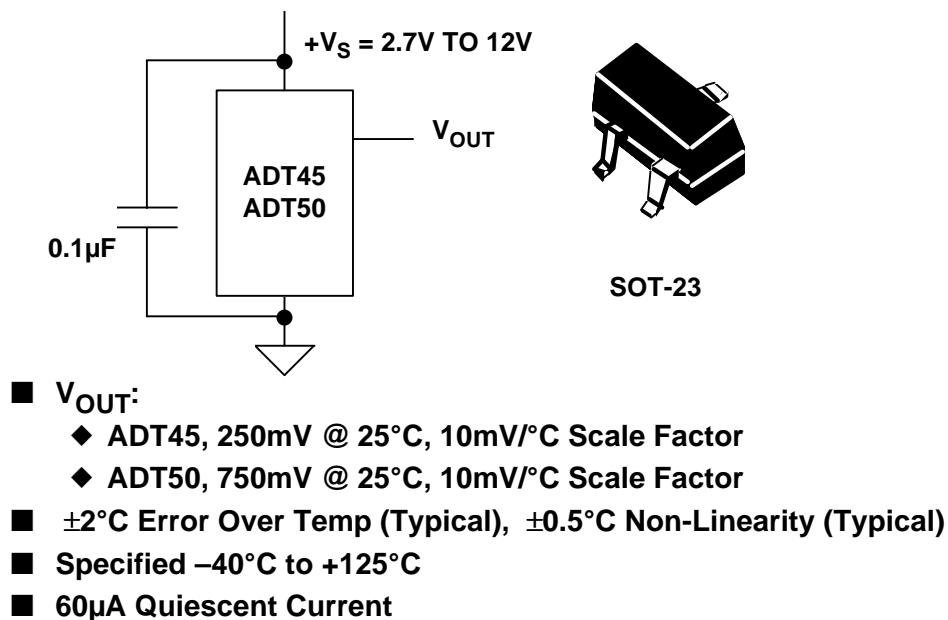

Figure 7.27

If the ADT45/ADT50 sensors are thermally attached and protected, they can be used in any temperature measurement application where the maximum temperature range of the medium is between -40°C to $+125^{\circ}\text{C}$. Properly cemented or glued to the surface of the medium, these sensors will be within 0.01°C of the surface temperature. Caution should be exercised, as any wiring to the device can act as heat pipes, introducing errors if the surrounding air-surface interface is not isothermal. Avoiding this condition is easily achieved by dabbing the leads of the sensor and the hookup wires with a bead of thermally conductive epoxy. This will ensure that the ADT45/ADT50 die temperature is not affected by the surrounding air temperature.

In the SOT-23-3 package, the thermal resistance junction-to-case, θ_{JC} , is 180°C/W. The thermal resistance case-to-ambient, θ_{CA} , is the difference between θ_{JA} and θ_{JC} , and is determined by the characteristics of the thermal connection. With no air flow and the device soldered on a PC board, θ_{JA} is 300°C/W. The temperature sensor's power dissipation, P_D , is the product of the total voltage across the device and its total supply current (including any current delivered to the load). The rise in die temperature above the medium's ambient temperature is given by:

$$T_J = P_D \times (\theta_{JC} + \theta_{CA}) + T_A.$$

Thus, the die temperature rise of an unloaded ADT45/ADT50 (SOT-23-3 package) soldered on a board in still air at 25°C and driven from a +5V supply (quiescent current = 60μA, $P_D = 300\mu\text{W}$) is less than 0.09°C. In order to prevent further temperature rise, it is important to minimize the load current, always keeping it less than 100μA.

The transient response of the ADT45/ADT50 sensors to a step change in temperature is determined by the thermal resistances and the thermal mass of the die and the case. The thermal mass of the case varies with the measurement medium since it includes anything that is in direct contact with the package. In all practical cases, the thermal mass of the case is the limiting factor in the thermal response time of the sensor and can be represented by a single-pole RC time constant. Thermal mass is often considered the thermal equivalent of electrical capacitance.

The thermal time constant of a temperature sensor is defined to be the time required for the sensor to reach 63.2% of the final value for a step change in the temperature. Figure 7.28 shows the thermal time constant of the ADT45/ADT50 series of sensors with the SOT-23-3 package soldered to 0.338" x 0.307" copper PC board as a function of air flow velocity. Note the rapid drop from 32 seconds to 12 seconds as the air velocity increases from 0 (still air) to 100 LFPM. As a point of reference, the thermal time constant of the ADT45/ADT50 series in a stirred oil bath is less than 1 second, which verifies that the major part of the thermal time constant is determined by the case.

The power supply pin of these sensors should be bypassed to ground with a 0.1μF ceramic capacitor having very short leads (preferably surface mount) and located as close to the power supply pin as possible. Since these temperature sensors operate on very little supply current and could be exposed to very hostile electrical environments, it is important to minimize the effects of EMI/RFI on these devices. The effect of RFI on these temperature sensors is manifested as abnormal DC shifts in the output voltage due to rectification of the high frequency noise by the internal IC junctions. In those cases where the devices are operated in the presence of high frequency radiated or conducted noise, a large value tantalum electrolytic capacitor (>2.2μF) placed across the 0.1μF ceramic may offer additional noise immunity.

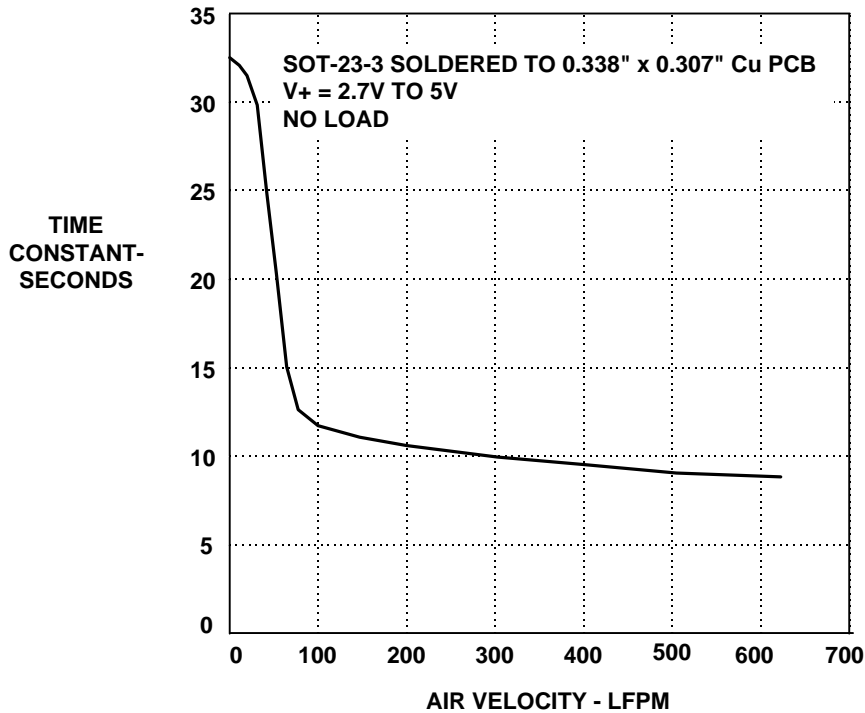
THERMAL RESPONSE IN FORCED AIR FOR SOT-23-3**Figure 7.28****Digital Output Temperature Sensors**

Temperature sensors which have digital outputs have a number of advantages over those with analog outputs, especially in remote applications. Opto-isolators can also be used to provide galvanic isolation between the remote sensor and the measurement system. A voltage-to-frequency converter driven by a voltage output temperature sensor accomplishes this function, however, more sophisticated ICs are now available which are more efficient and offer several performance advantages.

The TMP03/TMP04 digital output sensor family includes a voltage reference, V_{PTAT} generator, sigma-delta ADC, and a clock source (see Figure 7.29). The sensor output is digitized by a first-order sigma-delta modulator, also known as the "charge balance" type analog-to-digital converter. This converter utilizes time-domain oversampling and a high accuracy comparator to deliver 12 bits of effective accuracy in an extremely compact circuit.

The output of the sigma-delta modulator is encoded using a proprietary technique which results in a serial digital output signal with a mark-space ratio format (see Figure 7.30) that is easily decoded by any microprocessor into either degrees centigrade or degrees Fahrenheit, and readily transmitted over a single wire. Most importantly, this encoding method avoids major error sources common to other modulation techniques, as it is clock-independent. The nominal output frequency is 35Hz at + 25°C, and the device operates with a fixed high-level pulse width (T1) of 10ms.

DIGITAL OUTPUT SENSORS: TMP03/04

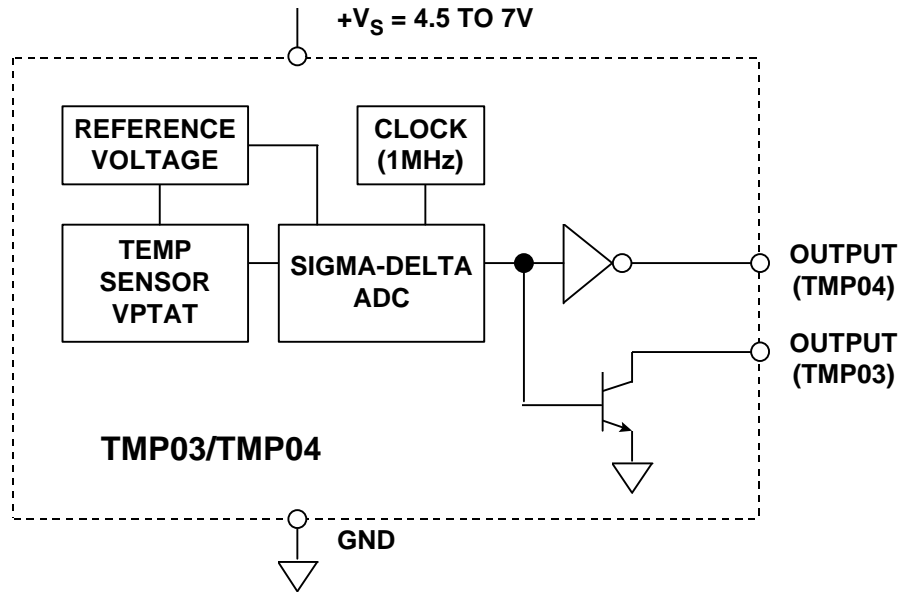
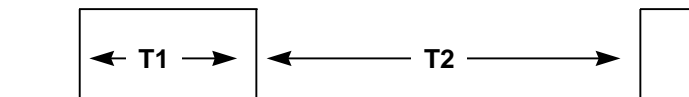

Figure 7.29

TMP03/TMP04 OUTPUT FORMAT



$$\text{TEMPERATURE (}^\circ\text{C)} = 235 - \left(\frac{400 \times T_1}{T_2} \right)$$

$$\text{TEMPERATURE (}^\circ\text{F)} = 455 - \left(\frac{720 \times T_1}{T_2} \right)$$

- T1 Nominal Pulse Width = 10ms
- $\pm 1.5^\circ\text{C}$ Error Over Temp, $\pm 0.5^\circ\text{C}$ Non-Linearity (Typical)
- Specified -40°C to $+100^\circ\text{C}$
- Nominal T_1/T_2 @ 0°C = 60%
- Nominal Frequency @ $+25^\circ\text{C}$ = 35Hz
- 6.5mW Power Consumption @ 5V
- TO-92, SO-8, or TSSOP Packages

Figure 7.30

TEMPERATURE SENSORS

The TMP03/TMP04 output is a stream of digital pulses, and the temperature information is contained in the mark-space ratio per the equations:

$$\text{Temperature (}^\circ\text{C)} = 235 - \left(\frac{400 \times T1}{T2} \right)$$

$$\text{Temperature (}^\circ\text{F)} = 455 - \left(\frac{720 \times T1}{T2} \right).$$

Popular microcontrollers, such as the 80C51 and 68HC11, have on-chip timers which can easily decode the mark-space ratio of the TMP03/TMP04. A typical interface to the 80C51 is shown in Figure 7.31. Two timers, labeled *Timer 0* and *Timer 1* are 16 bits in length. The 80C51's system clock, divided by twelve, provides the source for the timers. The system clock is normally derived from a crystal oscillator, so timing measurements are quite accurate. Since the sensor's output is ratiometric, the actual clock frequency is not important. This feature is important because the microcontroller's clock frequency is often defined by some external timing constraint, such as the serial baud rate.

INTERFACING TMP04 TO A MICROCONTROLLER

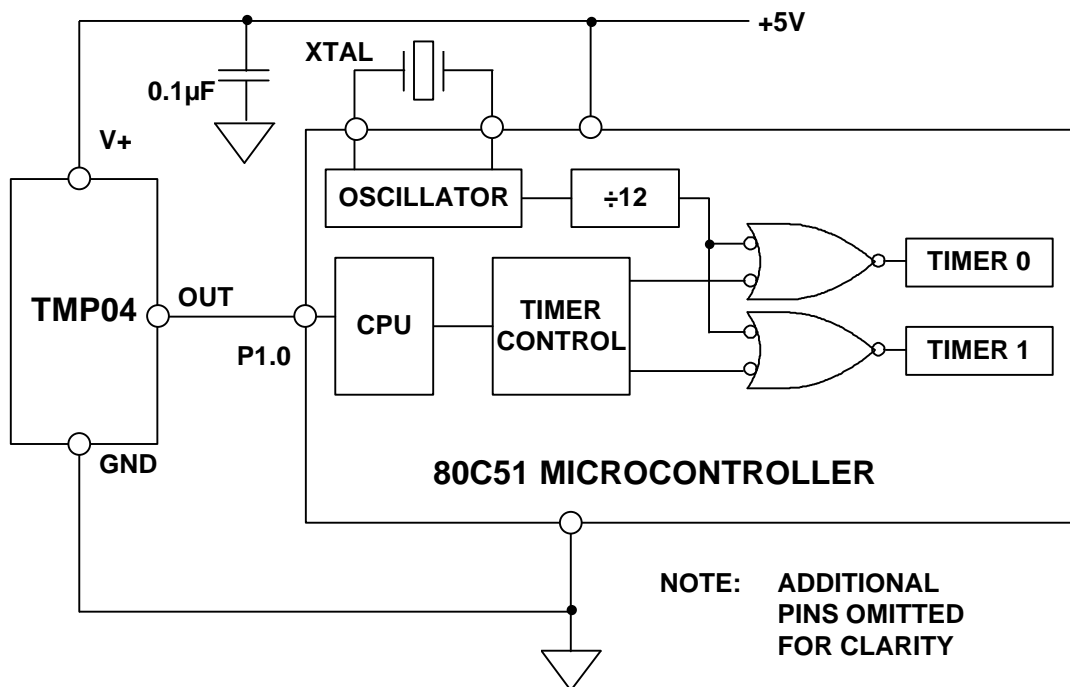

Figure 7.31

Software for the sensor interface is straightforward. The microcontroller simply monitors I/O port P1.0, and starts *Timer 0* on the rising edge of the sensor output. The microcontroller continues to monitor P1.0, stopping *Timer 0* and starting *Timer 1* when the sensor output goes low. When the output returns high, the sensor's T1 and T2 times are contained in registers *Timer 0* and *Timer 1*, respectively. Further software routines can then apply the conversion factor shown in the equations above and calculate the temperature.

The TMP03/TMP04 are ideal for monitoring the thermal environment within electronic equipment. For example, the surface mounted package will accurately reflect the thermal conditions which affect nearby integrated circuits. The TO-92 package, on the other hand, can be mounted above the surface of the board to measure the temperature of the air flowing over the board.

The TMP03 and TMP04 measure and convert the temperature at the surface of their own semiconductor chip. When they are used to measure the temperature of a nearby heat source, the thermal impedance between the heat source and the sensor must be considered. Often, a thermocouple or other temperature sensor is used to measure the temperature of the source, while the TMP03/TMP04 temperature is monitored by measuring T1 and T2. Once the thermal impedance is determined, the temperature of the heat source can be inferred from the TMP03/TMP04 output.

One example of using the TMP04 to monitor a high power dissipation microprocessor or other IC is shown in Figure 7.32. The TMP04, in a surface mount package, is mounted directly beneath the microprocessor's pin grid array (PGA) package. In a typical application, the TMP04's output would be connected to an ASIC where the mark-space ratio would be measured. The TMP04 pulse output provides a significant advantage in this application because it produces a linear temperature output, while needing only one I/O pin and without requiring an ADC.

MONITORING HIGH POWER MICROPROCESSOR OR DSP WITH TMP04

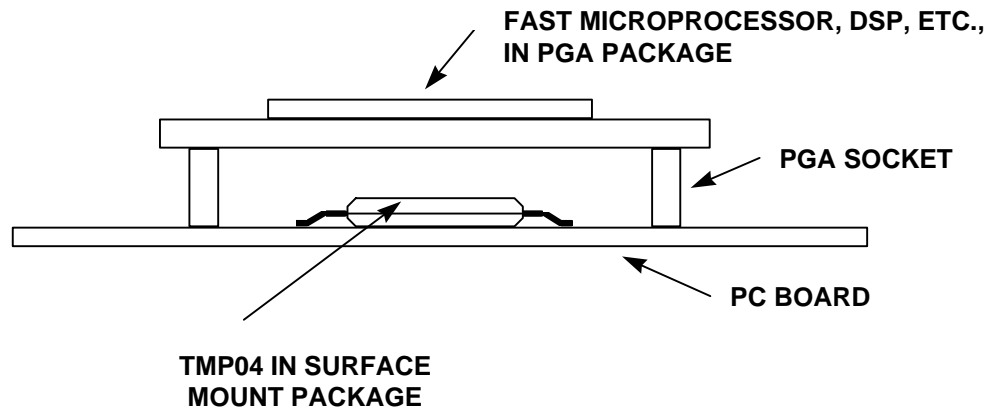

Figure 7.32

Thermostatic Switches and Setpoint Controllers

Temperature sensors used in conjunction with comparators can act as thermostatic switches. ICs such as the ADT05 accomplish this function at low cost and allow a single external resistor to program the setpoint to 2°C accuracy over a range of -40°C to +150°C (see Figure 7.33). The device asserts an open collector output when the ambient temperature exceeds the user-programmed setpoint temperature. The ADT05 has approximately 4°C of hysteresis which prevents rapid thermal on/off cycling. The ADT05 is designed to operate on a single supply voltage from +2.7V to

TEMPERATURE SENSORS

+7.0V facilitating operation in battery powered applications as well as industrial control systems. Because of low power dissipation ($200\mu\text{W}$ @ 3.3V), self-heating errors are minimized, and battery life is maximized. An optional internal $200\text{k}\Omega$ pull-up resistor is included to facilitate driving light loads such as CMOS inputs.

The setpoint resistor is determined by the equation:

$$R_{\text{SET}} = \frac{39\text{M}\Omega^{\circ}\text{C}}{T_{\text{SET}}(^{\circ}\text{C}) + 281.6^{\circ}\text{C}} - 90.3\text{k}\Omega.$$

The setpoint resistor should be connected directly between the R_{SET} pin (Pin 4) and the GND pin (Pin 5). If a ground plane is used, the resistor may be connected directly to this plane at the closest available point.

The setpoint resistor can be of nearly any resistor type, but its initial tolerance and thermal drift will affect the accuracy of the programmed switching temperature. For most applications, a 1% metal-film resistor will provide the best tradeoff between cost and accuracy. Once R_{SET} has been calculated, it may be found that the calculated value does not agree with readily available standard resistors of the chosen tolerance. In order to achieve a value as close as possible to the calculated value, a compound resistor can be constructed by connecting two resistors in series or parallel.

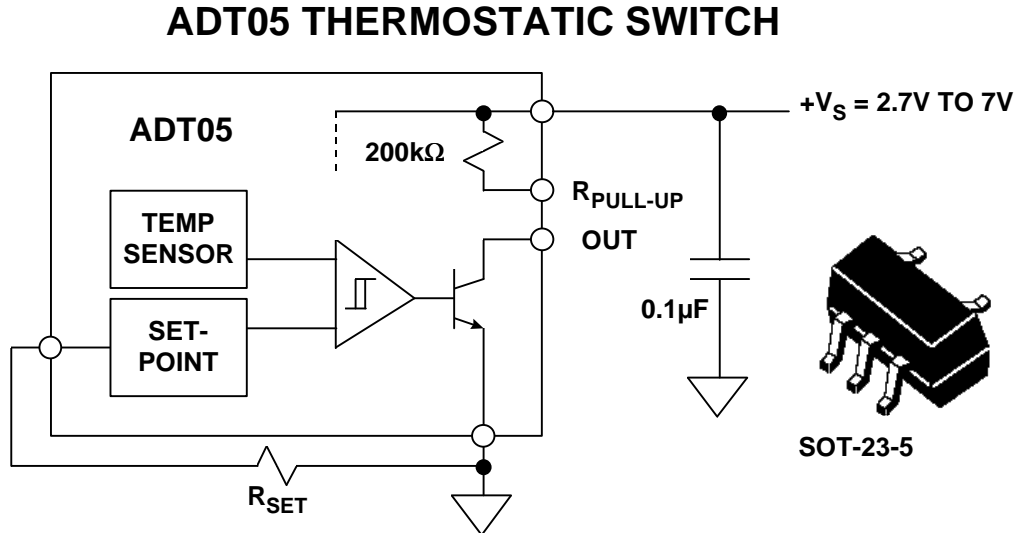

- $\pm 2^{\circ}\text{C}$ Setpoint Accuracy
- 4°C Preset Hysteresis
- Specified Operating Range: -40°C to $+150^{\circ}\text{C}$
- Power Dissipation: $200\mu\text{W}$ @ 3.3V

Figure 7.33

The TMP01 is a dual setpoint temperature controller which also generates a PTAT output voltage (see Figure 7.34 and 7.35). It also generates a control signal from one of two outputs when the device is either above or below a specific temperature range. Both the high/low temperature trip points and hysteresis band are determined by user-selected external resistors.

TMP01 PROGRAMMABLE SETPOINT CONTROLLER

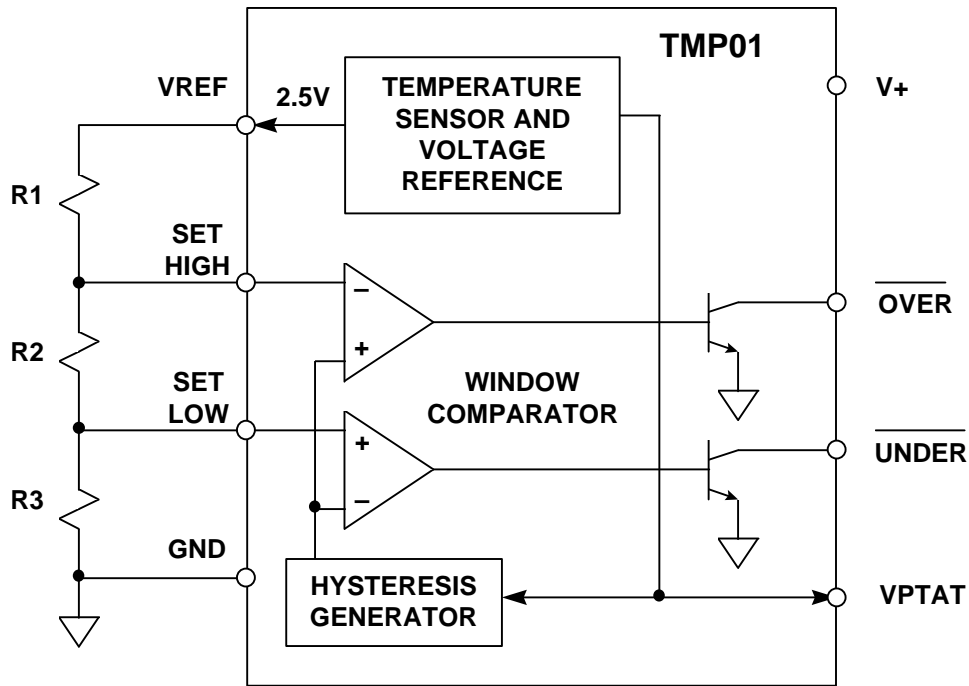

Figure 7.34

The TMP01 consists of a bandgap voltage reference combined with a pair of matched comparators. The reference provides both a constant 2.5V output and a PTAT output voltage which has a precise temperature coefficient of 5mV/K and is 1.49V (nominal) at +25°C. The comparators compare VPTAT with the externally set temperature trip points and generate an open-collector output signal when one of their respective thresholds has been exceeded.

Hysteresis is also programmed by the external resistor chain and is determined by the total current drawn out of the 2.5V reference. This current is mirrored and used to generate a hysteresis offset voltage of the appropriate polarity after a comparator has been tripped. The comparators are connected in parallel, which guarantees that there is no hysteresis overlap and eliminates erratic transitions between adjacent trip zones.

TEMPERATURE SENSORS

The TMP01 utilizes laser trimmed thin-film resistors to maintain a typical temperature accuracy of $\pm 1^\circ\text{C}$ over the rated temperature range. The open-collector outputs are capable of sinking 20mA, enabling the TMP01 to drive control relays directly. Operating from a +5V supply, quiescent current is only 500 μA maximum.

TMP01 SETPOINT CONTROLLER KEY FEATURES

- V_C : 4.5 to 13.2V
- Temperature Output: VPTAT, +5mV/K
- Nominal 1.49V Output @ 25°C
- $\pm 1^\circ\text{C}$ Typical Accuracy Over Temperature
- Specified Operating Range: -55°C to $+ 125^\circ\text{C}$
- Resistor-Programmable Hysteresis
- Resistor-Programmable Setpoints
- Precision 2.5V $\pm 8\text{mV}$ Reference
- 400 μA Quiescent Current, 1 μA in Shutdown
- Packages: 8-Pin Dip, 8-Pin SOIC, 8-Pin TO-99
- Other Setpoint Controllers:
 - ◆ Dual Setpoint Controllers: ADT22/ADT23
(3V Versions of TMP01 with Internal Hysteresis)
 - ◆ Quad Setpoint Controller: ADT14

Figure 7.35

The ADT22/23-series are similar to the TMP01 but have internal hysteresis and are designed to operate on a 3V supply. A quad (ADT14) setpoint controller is also available.

ADCs With On-Chip Temperature Sensors

The AD7816/7817/7818-series digital temperature sensors have on-board temperature sensors whose outputs are digitized by a 10-bit 9 μs conversion time switched capacitor SAR ADC. The serial interface is compatible with the Intel 8051, Motorola SPI™ and QSPI™, and National Semiconductor's MICROWIRE™ protocol. The device family offers a variety of input options for further flexibility. The AD7416/7417/7418 are similar but have standard serial interfaces. Functional block diagrams of the AD7816, AD7817, and AD7818 are shown in Figures 7.36, 37, and 38, and key specifications in Figure 7.39

AD7816 10-BIT DIGITAL TEMPERATURE SENSOR WITH SERIAL INTERFACE

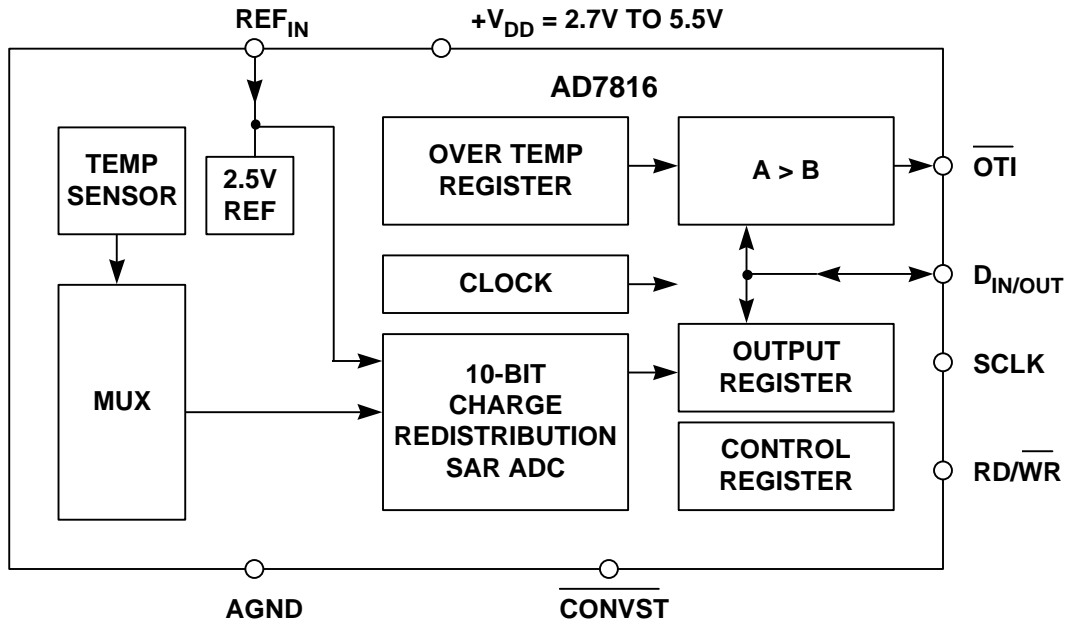

Figure 7.36

AD7817 10-BIT MUXED INPUT ADC WITH TEMP SENSOR

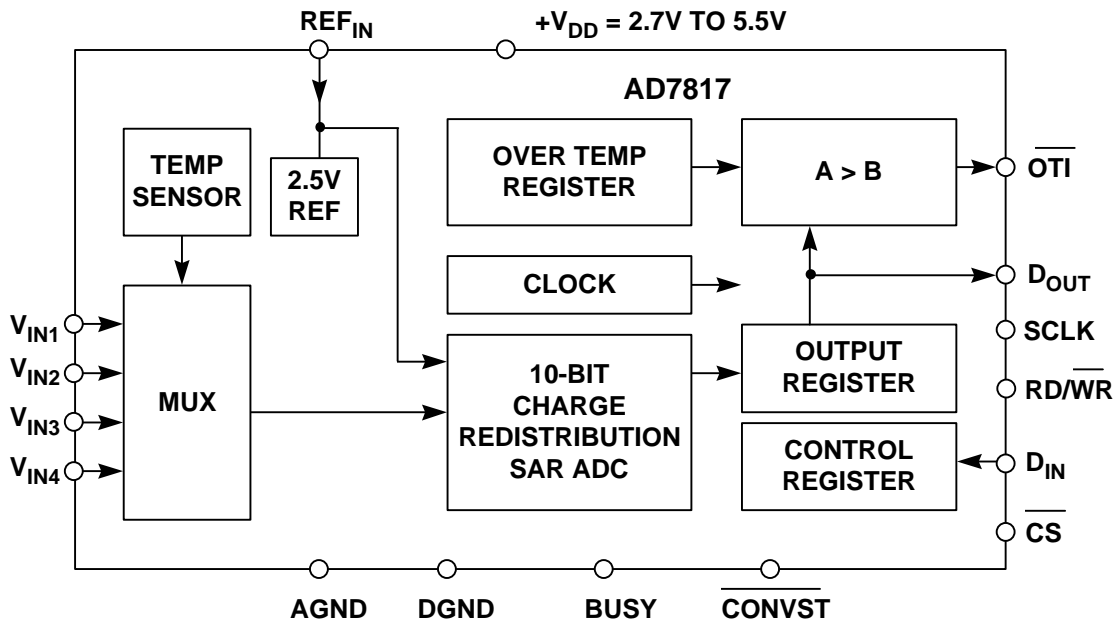

Figure 7.37

AD7818 SINGLE INPUT 10-BIT ADC WITH TEMP SENSOR

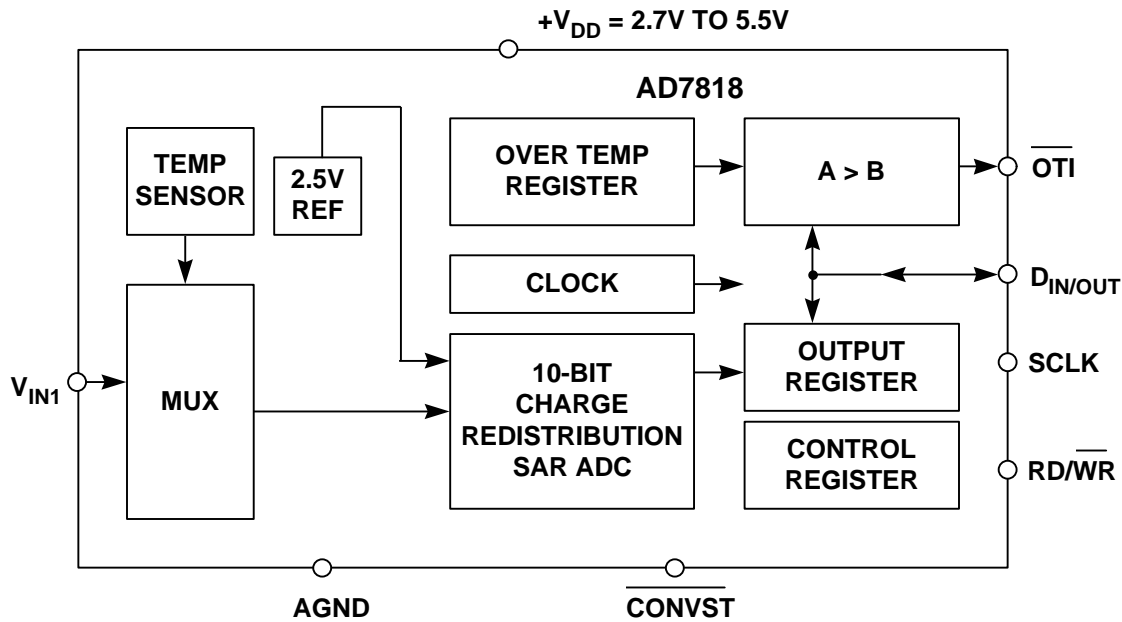

Figure 7.38

**AD7816/7817/7818 - SERIES TEMP SENSOR
10-BIT ADCs WITH SERIAL INTERFACE**

- 10-Bit ADC with 9µs Conversion Time
- Flexible Serial Interface (Intel 8051, Motorola SPI™ and QSPI™, National MICROWIRE™)
- On-Chip Temperature Sensor: -55°C to +125°C
- Temperature Accuracy: ± 2°C from -40°C to +85°C
- On-Chip Voltage Reference: 2.5V ±1%
- +2.7V to +5.5V Power Supply
- 4µW Power Dissipation at 10Hz Sampling Rate
- Auto Power Down after Conversion
- Over-Temp Interrupt Output
- Four Single-Ended Analog Input Channels: AD7817
- One Single-Ended Analog Input Channel: AD7818
- AD7416/7417/7418: Similar, but have I²C Compatible Interface

Figure 7.39

MICROPROCESSOR TEMPERATURE MONITORING

Today's computers require that hardware as well as software operate properly, in spite of the many things that can cause a system crash or lockup. The purpose of hardware monitoring is to monitor the critical items in a computing system and take corrective action should problems occur.

Microprocessor supply voltage and temperature are two critical parameters. If the supply voltage drops below a specified minimum level, further operations should be halted until the voltage returns to acceptable levels. In some cases, it is desirable to reset the microprocessor under "brownout" conditions. It is also common practice to reset the microprocessor on power-up or power-down. Switching to a battery backup may be required if the supply voltage is low.

Under low voltage conditions it is mandatory to inhibit the microprocessor from writing to external CMOS memory by inhibiting the Chip Enable signal to the external memory.

Many microprocessors can be programmed to periodically output a "watchdog" signal. Monitoring this signal gives an indication that the processor and its software are functioning properly and that the processor is not stuck in an endless loop.

The need for hardware monitoring has resulted in a number of ICs, traditionally called "microprocessor supervisory products," which perform some or all of the above functions. These devices range from simple manual reset generators (with debouncing) to complete microcontroller-based monitoring sub-systems with on-chip temperature sensors and ADCs. Analog Devices' ADM-family of products is specifically to perform the various microprocessor supervisory functions required in different systems.

CPU temperature is critically important in the Pentium II microprocessors. For this reason, all new Pentium II devices have an on-chip substrate PNP transistor which is designed to monitor the actual chip temperature. The collector of the substrate PNP is connected to the substrate, and the base and emitter are brought out on two separate pins of the Pentium II.

The ADM1021 Microprocessor Temperature Monitor is specifically designed to process these outputs and convert the voltage into a digital word representing the chip temperature. The simplified analog signal processing portion of the ADM1021 is shown in Figure 7.40.

The technique used to measure the temperature is identical to the " ΔV_{BE} " principle previously discussed. Two different currents (I and $N \cdot I$) are applied to the sensing transistor, and the voltage measured for each. In the ADM1021, the nominal currents are $I = 6\mu\text{A}$, ($N = 17$), $N \cdot I = 102\mu\text{A}$. The change in the base-emitter voltage, ΔV_{BE} , is a PTAT voltage and given by the equation:

$$\Delta V_{BE} = \frac{kT}{q} \ln(N).$$

TEMPERATURE SENSORS

Figure 7.40 shows the external sensor as a substrate transistor, provided for temperature monitoring in the microprocessor, but it could equally well be a discrete transistor. If a discrete transistor is used, the collector should be connected to the base and not grounded. To prevent ground noise interfering with the measurement, the more negative terminal of the sensor is not referenced to ground, but is biased above ground by an internal diode. If the sensor is operating in a noisy environment, C may be optionally added as a noise filter. Its value is typically 2200pF, but should be no more than 3000pF.

ADM1021 MICROPROCESSOR TEMPERATURE MONITOR INPUT SIGNAL CONDITIONING CIRCUITS

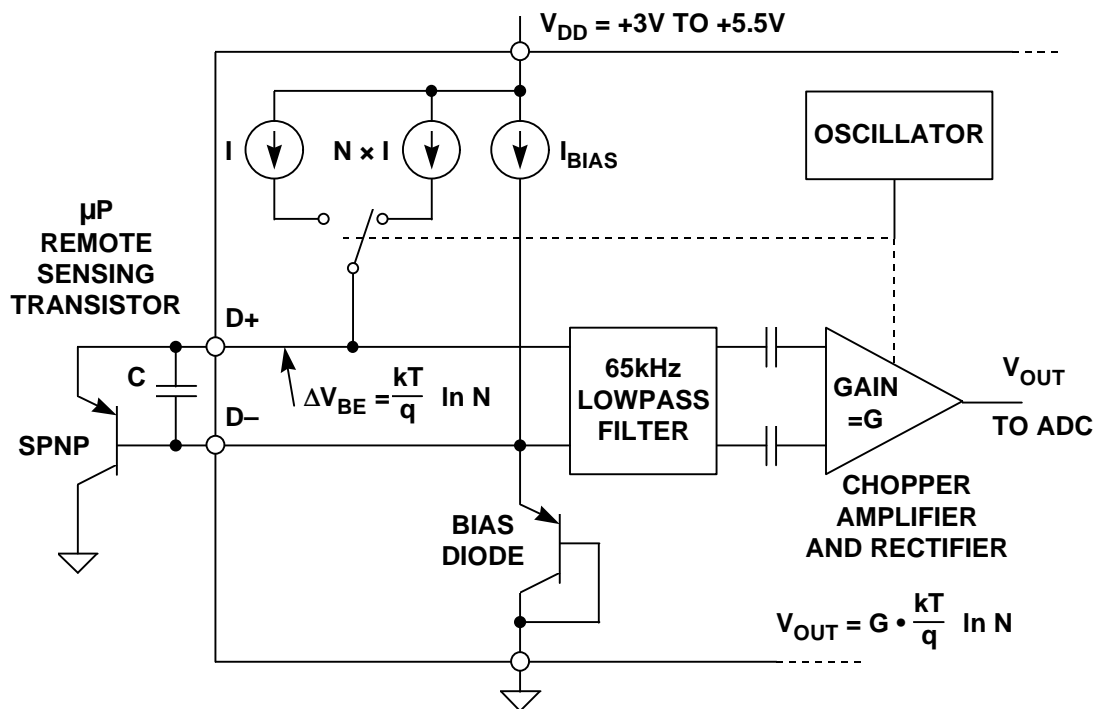

Figure 7.40

To measure ΔV_{BE} , the sensing transistor is switched between operating currents of I and $N \cdot I$. The resulting waveform is passed through a 65kHz lowpass filter to remove noise, then to a chopper-stabilized amplifier which performs the function of amplification and synchronous rectification. The resulting DC voltage is proportional to ΔV_{BE} and is digitized by an 8-bit ADC. To further reduce the effects of noise, digital filtering is performed by averaging the results of 16 measurement cycles.

In addition, the ADM1021 contains an on-chip temperature sensor, and its signal conditioning and measurement is performed in the same manner.

One LSB of the ADC corresponds to 1°C, so the ADC can theoretically measure from -128°C to +127°C, although the practical lowest value is limited to -65°C due to device maximum ratings. The results of the local and remote temperature measurements are stored in the local and remote temperature value registers, and are compared with limits programmed into the local and remote high and low limit registers as shown in Figure 7.41. An $\overline{\text{ALERT}}$ output signals when the on-chip or remote temperature is out of range. This output can be used as an interrupt, or as an SMBus alert.

The limit registers can be programmed, and the device controlled and configured, via the serial System Management Bus (SMBus). The contents of any register can also be read back by the SMBus. Control and configuration functions consist of: switching the device between normal operation and standby mode, masking or enabling the $\overline{\text{ALERT}}$ output, and selecting the conversion rate which can be set from 0.0625Hz to 8Hz.

ADM1021 SIMPLIFIED BLOCK DIAGRAM

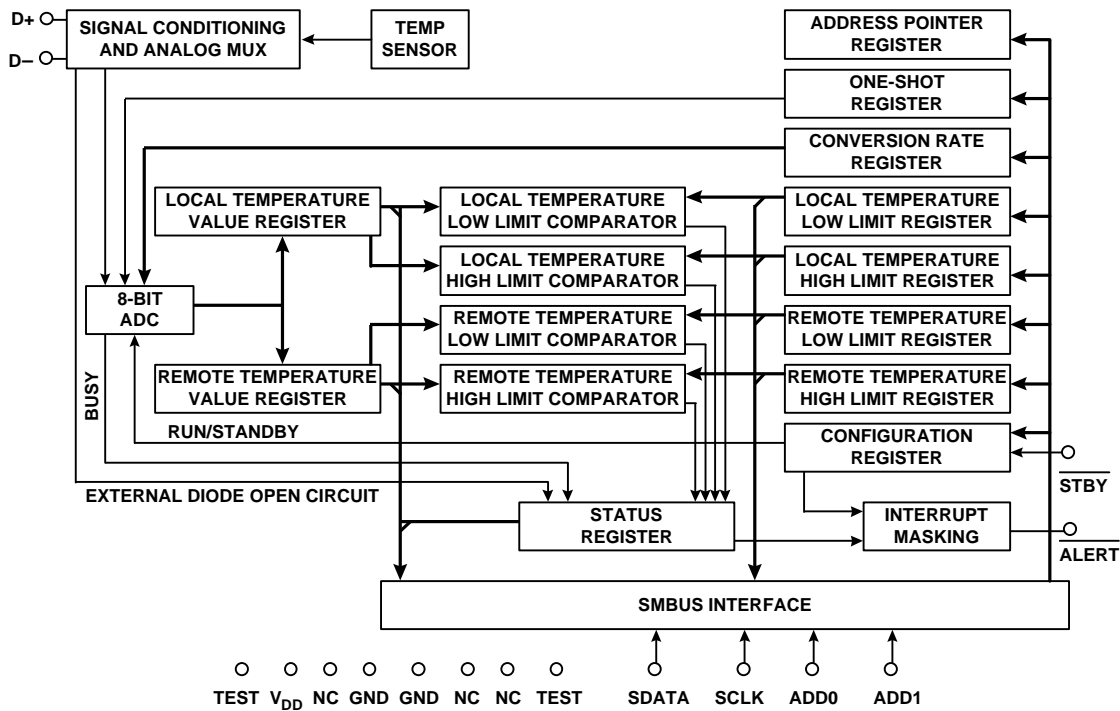

Figure 7.41

ADM1021 KEY SPECIFICATIONS

- On-Chip and Remote Temperature Sensing
- 1°C Accuracy for On-Chip Sensor
- 3°C Accuracy for Remote Sensor
- Programmable Over / Under Temperature Limits
- 2-Wire SMBus Serial Interface
- 70µA Max Operating Current
- 3µA Standby Current
- +3V to +5.5V Supplies
- 16-Pin QSOP Package

Figure 7.42

REFERENCES

1. Ramon Pallas-Areny and John G. Webster, **Sensors and Signal Conditioning**, John Wiley, New York, 1991.
2. Dan Sheingold, Editor, **Transducer Interfacing Handbook**, Analog Devices, Inc., 1980.
3. Walt Kester, Editor, **1992 Amplifier Applications Guide**, Section 2, 3, Analog Devices, Inc., 1992.
4. Walt Kester, Editor, **System Applications Guide**, Section 1, 6, Analog Devices, Inc., 1993.
5. Jim Williams, *Thermocouple Measurement*, **Linear Technology Application Note 28**, Linear Technology Corporation.
6. Dan Sheingold, **Nonlinear Circuits Handbook**, Analog Devices, Inc.
7. James Wong, *Temperature Measurements Gain from Advances in High-precision Op Amps*, **Electronic Design**, 15 May 1986.
8. *OMEGA Temperature Measurement Handbook*, Omega Instruments, Inc.
9. **Handbook of Chemistry and Physics**, Chemical Rubber Co.
10. Paul Brokaw, *A Simple Three-Terminal IC Bandgap Voltage Reference*, **IEEE Journal of Solid State Circuits**, Vol. SC-9, December, 1974.