

PAPER • OPEN ACCESS

## The quantum vector digital voltmeter of INMETRO

To cite this article: Waldemar G Kuerten Ihlenfeld and Regis P Landim 2016 *J. Phys.: Conf. Ser.* **733** 012079

View the [article online](#) for updates and enhancements.

# The quantum vector digital voltmeter of INMETRO

**Waldemar G Kuerten Ihlenfeld, Regis P Landim**

National Institute of Metrology, Quality and Technology – INMETRO, Av. Nossa Senhora das Graças no. 50 – Xérem, 25250-020 Duque de Caxias/RJ, Brazil.

E-mail: wgkihlenfeld@gmail.com

**Abstract.** The paper describes the quantum vector digital voltmeter developed at INMETRO, which is based on a programmable Josephson voltage synthesizer. The system employs digital regulation for phase-alignment and frequency synchronization of signals, is fully automated and allows calibration of ac sources and analog-to-digital converters with uncertainties bearing some parts of  $10^{-07}$  up to frequencies of around 500 Hz.

## 1. Introduction

The Josephson Effect was discovered 54 years ago [1]. Its metrological applications explore its ability of being a nearly perfect quantum converter of frequency into an extremely accurate dc voltage (with typical uncertainties bearing only some  $10^{-10}$  V/V). Josephson systems are nowadays worldwide spread and common in National Metrology Institutes (NMIs). They are used to maintain and disseminate the unit volt (in direct current or dc). Recent advances focus on the development of digital-to-analog converters (DACs) based on the Josephson Effect to provide a quantum reference for the calibration of alternating (ac) signals. Here the developments rely on the quantum generation of ac signals of the same frequency, close resembling the ac signal to be calibrated. These pursuits follow two distinct ways: 1) The generation of ac signals by stepwise-approximated waveforms (like a common DAC) called programmable step-driven Josephson voltage synthesizer - PJVS or 2) pulse driven signal generation, akin to delta-sigma signal generation. Although the first covers low frequencies from dc to 1 kHz up to 10 V peak [2], the second so far generates signals from 1 kHz to 1 MHz (and dc) up to around 1.4 V peak [3]. INMETRO's system is based on a PJVS developed at the National Institute of Standards and Technology (NIST) [4,5]. However, a PJVS alone does not guarantee the traceability of ac signals. INMETRO's PJVS had thus to be integrated as an ac reference into a complex system devised for that purpose. This system is called quantum vector digital voltmeter and differs from other developments done elsewhere in respect with hardware and software. It uses an automated and unique patent pending phase- and frequency- synchronization of signals (to be calibrated against the PJVS), managed by an exquisitely sensitive digital regulation as explained next.

## 2. The AC Quantum Voltmeter



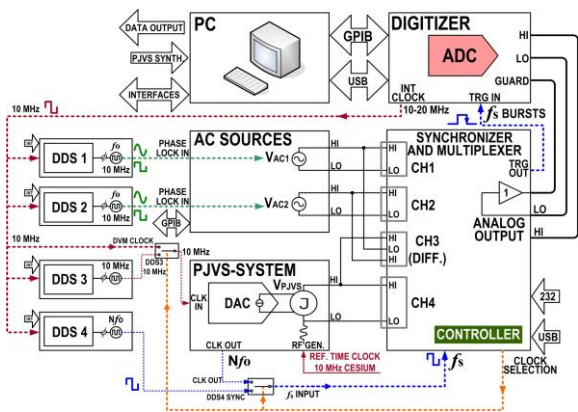

**Figure 1.** The quantum digital voltmeter (QDVM) uses a PJVS system as a reference, a synchronizer with a multiplexer for comparing signals, ac sources, a 28-bit integrating digitizer and four direct-digital-synthesizers for synchronization purposes (see text).

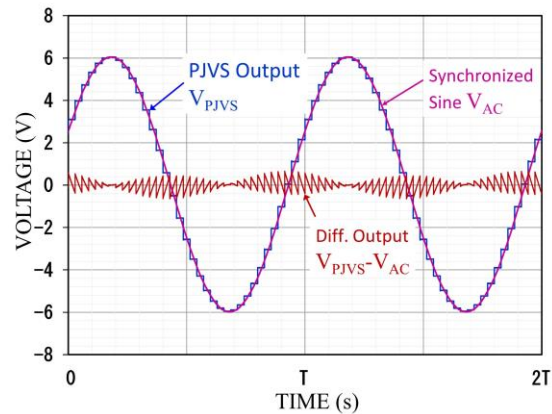

**Figure 2.** The ac signal is synchronized with the stepwise approximated PJVS waveform by digital regulation. The ADC samples the resulting differential voltage close to its zero crossings to determine the magnitude of  $V_{AC}$ .

Figure 1 represents the system developed at INMETRO using a PJVS (at the bottom middle). The PJVS arrays are biased by a current DAC and a microwave signal of nearly 20 GHz, locked to the 10 MHz of a cesium time standard [4].

The devices under test (DUT) are the ac sources  $V_{AC1}$  and  $V_{AC2}$ , and the ADC is a 28-bit integrating digital converter, which delivers the 10 MHz internal clock for synchronization purposes and signal generation of the PJVS. The ac sources  $V_{AC1}$  and  $V_{AC2}$  are phase-locked by direct digital synthesizers (DDS), i.e., DDS 1 and DDS 2, whereas DDS 3 allows the synchronization of the PJVS with other sources. DDS 4 generates the sampling frequency  $f_s$  to sample the ac signals  $V_{PJVS}$ ,  $V_{AC1}$  and  $V_{AC2}$ .

The synchronizer possesses four channels and allows direct and differential measurements [6, 7] of the ac sources with the PJVS to be made. It manages also the synchronization of the system by enabling the selection of clocks (the dotted busses in figure 1) and the synchronous data-acquisition by the ADC. Here a coherent signal generation (of the ac sources and PJVS) and data acquisition (by the ADC) takes place with the 10 MHz ADC clock reference. The ADC data are sampled with  $N$  steps (PJVS-steps) or samples per period over a pre-defined  $M$  (integer) number of periods. Samples are taken on the flat portion of the PJVS plateaus, allowing enough time for the signals to settle in the ADC circuitry after properly aligning the aperture window on each plateau. This alignment is done by DDS 4 or by using the CLK OUT output of the PJVS system, as described in [7]. The synchronization of the ac sources  $V_{AC1}$  and  $V_{AC2}$  is accomplished by repeated sampling these signals, determining their phase differences (when compared with the PJVS signal) and by fine trimming DDS 1 and DDS 2 in a feedback loop over a finite time span. Precise and calculable frequency variations yield precise phase-shifts within some nano-radian resolution. A deeper treatment of this patent pending algorithm is described in [7]. This results in perfectly aligned signals, as figure 2 shows.

### 3. Measurement Capabilities

The synchronizer and multiplexer allow the system to make direct as well as differential voltage measurements. These are depicted schematically in figure 3. Direct measurements are used to first calibrate the ADC and its gain at a particular signal frequency, sampling frequency and aperture time.

Figure 3 A and E shows the multiplexing of either the PJVS and  $V_{AC1}$  or  $V_{AC2}$  for calibrating  $V_{AC1}$  or  $V_{AC2}$  with a prior calibration of the ADC against the known PJVS' plateaus.

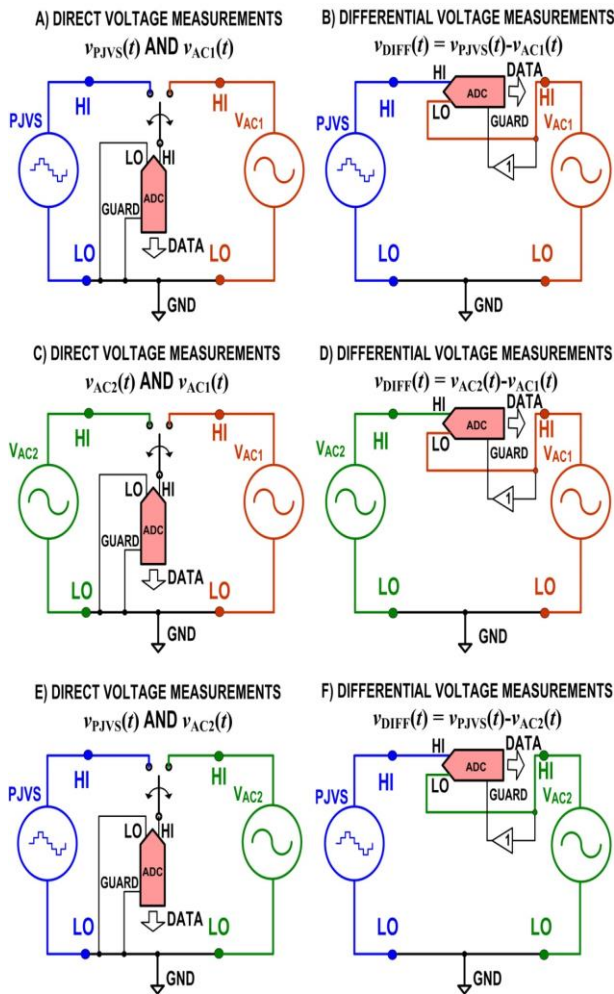
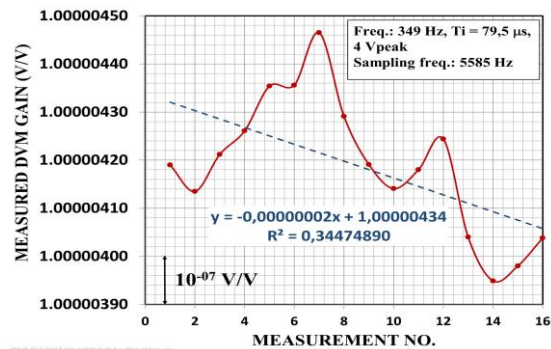

**Figure 3.** The quantum voltmeter allows direct voltage measurements A) C) and E), as well as the most precise differential measurements B) D) and F) for determining the magnitudes of  $V_{AC1}$  or  $V_{AC2}$ . Comparisons of two continuous ac voltages is also possible as shown in E) and F).

ADC's errors are computed from a voltage ratio measurement, i.e., the fast Fourier transform (FFT) of the tabulated (or programmed) PJVS plateaus is divided by the FFT of the ADC measured plateau values, resulting in the determination of the ADC gain at the fundamental frequency. Figure 4 shows 16 ADC gain determinations. Variations of ADC's gain as much as some parts of  $10^{-7}$  are common and may vary (during measurements) mainly due to internal temperature fluctuations in the ADC circuitry and ADC's reference voltage. After sampling the ac sources, the FFT of their measured data is multiplied by the ADC gain at that particular fundamental frequency leading to the correct determination of the magnitude of either  $V_{AC1}$  or  $V_{AC2}$ , and their harmonic content.

A direct comparison between two ac sources at the same frequency is also possible by substituting the PJVS by  $V_{AC2}$ , which can then be compared with  $V_{AC1}$  as shown in figure 3 C and 3 D.

Differential measurements as depicted in figure 3 B, D and F demand the signals to be perfectly phase-synchronized (phase aligned) to minimize the amplitude of the differential voltages. The smaller the differential voltage is, the smaller is the effect of the ADC's errors on the accuracy of voltage measurements. Differential voltage measurements result in much more accurate amplitude



**Figure 4.** Measured gains of the ADC over 16 measurements (slightly over a 30 minutes measurement time) against the PJVS. A gain drift of  $2E-8$  V/measurement is noticeable from a linear data fitting as shown. Variations of some parts of  $10^{-7}$  during measurements are common for ADCs.

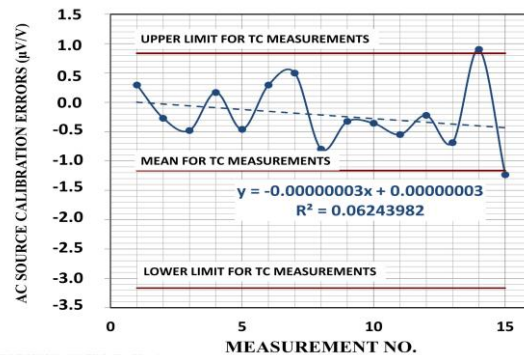

**Figure 5.** Calibration errors of an ac source operating at 349 Hz and 4 V peak. PJVS differential calibrations indicate that the source error is around  $\pm 1E-6$  V/V indicating a linear drift of  $3E-8$  V/V. The mean of 2500 thermal converter measurements lays close to  $-1E-6$  V/V but its uncertainty is around  $\pm 2E-6$  V/V from the mean (including instabilities of the source).

determinations, allowing measurement uncertainties of some parts in  $10^{-7}$  or even  $10^{-8}$  to be attained. For that, the ADC or sampler is tied with its LO-terminal connected with the HI-output of one of the ac sources (see figure 3 B, D, and F). The ADC HI-terminal is always tied with the HI-terminal of the PJVS because of its fast changing steps. The guard-terminal is driven by the same potential of the HI-terminal of an ac source via a unity-gain buffer amplifier to reduce ADC common-mode errors. Common-mode effects may substantially impair measurements, since some unavoidable coupling among guard-, LO- and HI-terminals of the ADC always do exist due to stray capacitances (also within its internal electronics).

Because the measurements are done in the frequency domain by using the fast Fourier-transform (FFT) on sampled data, it is possible to determine the harmonic content of  $V_{AC1}$  and  $V_{AC2}$  with quantum (or fundamental) accuracy, including its real and imaginary parts. Therefore, this system is thus called a vector voltmeter. This opens up new applications as in impedance bridges, where voltage ratios are used to determine impedances.

Figure 5 shows calibration errors of an ac source operating at 349 Hz (and 4 V peak) when compared with the PJVS and a primary thermal converter (TC). The agreement between calibrations with PJVS and TC are on the mean smaller than  $\pm 10^{-6}$  V/V. Thermal ac-dc transfer measurements show much higher dispersion, so that only the mean and the  $\pm 1 \sigma$  (standard deviation of measurement and TC calibration uncertainty) upper and lower limits around the mean are shown. Measurements with a TC encompassed 2500 determinations over three days and were done after the measurements with the PJVS to avoid the circulation of ground-loop currents between both systems. The measurements suggest the presence of a small systematic deviation of  $+5 \cdot 10^{-7}$  V/V between PJVS and TC-based measurements. This may be attributed to the fact that TC measurements were done in different days and due to drifts of the ac source. More stable sources are necessary for such investigations.

#### 4. Conclusions and Outlook

The capabilities of the new quantum voltmeter [8] allow a sensible reduction of measurement uncertainties of ac quantities to limits never hitherto attained. Future developments will focus on widening its operation towards the audio frequency range and on investigations of other recondite effects in the ADC.

Research efforts are presently devoted to extend the frequency range of the system depicted in figure 1 towards the audio and MHz frequency range, by using commensurate frequencies and Undersampling [9]. Meanwhile, new ac sources of highest stability and low harmonic content are under development, which will be integrated into the quantum voltmeter to allow even lower measurement uncertainties to be attained.

#### Acknowledgment

This work is being conducted at Inmetro under research contract no. 52600.057476.

#### References

- [1] Josephson B D 1962 Possible new effects in superconductive tunneling *Phys. Lett.* **1**(7) p. 251-253.
- [2] Lee J et al 2013 An ac quantum voltmeter based on a 10V programmable Josephson array *Metrologia* **50** p. 612–622.
- [3] Benz S P and Waltman S B 2014 Pulse-bias electronics and techniques for a Josephson arbitrary waveform synthesizer *IEEE Trans. Appl. Supercond.* **24**(6).

- [4] Burroughs C J et al 2011 NIST 10 V programmable Josephson voltage standard system *IEEE Trans. Instrum. Meas.* **60**(7) p. 2482-2488.
- [5] Burroughs C J et al 2009 A 10 volt turnkey programmable Josephson voltage standard for dc and stepwise-approximated waveforms *Measure* **4**(3) p. 70-75.
- [6] Rüfenacht A, Burroughs C J, Dresselhaus P D, and Benz S P 2013 Differential sampling measurement of a 7 V RMS sine wave with a programmable Josephson voltage standard *IEEE Trans. Instrum. Meas.* **62**(6) p. 1587-1593.
- [7] Kuerten Ihlenfeld W G and Landim R P 2015 An automated Josephson-based AC-voltage calibration system *IEEE Trans. Instrum. Meas.* **64**(6) p. 1779-1784.
- [8] Kuerten Ihlenfeld W G and Landim R P 2015 The quantum vector voltmeter of Inmetro XI Semetro Conf. Digest no. 187 ISBN 978-85-86768-10-1.
- [9] Kuerten Ihlenfeld W G and Landim R P 2016 Investigations on extending the frequency range of PJVS based AC voltage calibrations by coherent subsampling *CPEM2016 Conf. Digest*, Ottawa, Canada.