

# High linearity Josephson-junction array structures

Victor Kornev<sup>a,\*</sup>, Igor Soloviev<sup>a</sup>, Nikolai Klenov<sup>a</sup>, Oleg Mukhanov<sup>b</sup>

<sup>a</sup> *Physics Department, Moscow State University, 119992 Moscow, Russia*

<sup>b</sup> *HYPRES Inc., 175 Clearbrook Road, Elmsford, NY 10523, USA*

Accepted 30 November 2007

Available online 6 March 2008

## Abstract

Possible approaches to synthesis of the array structures capable of providing highly linear voltage response have been studied in detail. The first way supposes synthesis of the series array by means of interferometer cells with sinusoidal response. The second one supposes synthesis of differential array structures using interferometer cells with  $|\sin(x)|$ -like voltage response. The interferometer cells can be replaced by parallel arrays to form a high-performance parallel-series differential structure. The traveling wave amplifier design is suggested to avoid limitations resulting from the distributed nature of the long arrays.

© 2008 Elsevier B.V. All rights reserved.

PACS: 85.25.Am; 85.25.Cp; 85.25.Dq

Keywords: Josephson-junction; Dc interferometer; Array structure; Linear voltage response; Amplifier

## 1. Introduction

SQIF (superconducting quantum interferometer filter) structures, which are non-periodic arrays of dc Josephson-junction interferometers, were suggested a few years ago [1,2]. The SQIF voltage response shows a single delta-like peak at zero magnetic field.

In case of vanishing inductances, the voltage response can be expressed analytically for both parallel and serial SQIFs [1,2]. Our analysis of the analytical expressions shows that it is impossible to provide highly linear response by any set of the cell areas. In order to provide highly linear response, *one should also change amplitudes of the cell responses*.

The purpose of the work is to develop an approach for synthesis of the serial arrays and series-parallel structures of dc interferometers capable of providing very linear triangular voltage response.

## 2. Synthesis of high linearity series array structures

If voltage response of a serial array of dc interferometers to a homogeneous magnetic field  $B$  is a periodic even function, we can develop the response in Fourier series as follows:

$$V(B) = \sum_k a_k \cos(k\omega_0 B). \quad (1)$$

One can consider array cells providing sinusoidal voltage responses with frequencies proportionate to the cell areas; basic frequency  $\omega_0$  can be expressed by basic area  $s_0$  in the following way:

$$\omega_0 = (2\pi/\Phi_0) \cdot s_0. \quad (2)$$

Let us now consider a periodic triangular response. In this case, harmonic amplitudes should show a *sinc*-like behaviour:

$$a(k\omega_0) = A \sum_k \frac{\sin^2(k\omega_0 \Delta B/2)}{(k\omega_0 \Delta B/2)^2}, \quad (3)$$

\* Corresponding author.

E-mail address: [kornev@phys.msu.ru](mailto:kornev@phys.msu.ru) (V. Kornev).

where  $2\Delta B$  is width of the triangular pulse,  $\omega_0 = 2\pi/B_T$ ,  $B_T$  -period of the voltage response to magnetic field  $B$ . Fig. 1 presents spectra of the responses with the same triangular pulse width  $\Delta B$  and different periods  $B_T = 5\Delta B$  (dash dotted lines) and  $B_T = 2\Delta B$  (thick solid lines). Inset shows these periodic responses (b and c), as well as response with a single triangular peak which corresponds to a continuous spectrum shown by solid line (a). It is significant that spectrum of the voltage response with minimum period  $B_T = 2\Delta B$  contains only odd harmonics with amplitudes decreasing monotonically with harmonic number  $k$  as  $1/k^2$ .

When a dc interferometer with critical current  $I_c$  is biased well above critical current ( $I_b > 2I_c$ ), its voltage response to magnetic field becomes close enough to a sine-wave. These interferometer cells may be used to compose a serial array providing a periodic linear voltage response. The array ought to consist of many groups of identical cells, i.e., with equal areas. Each group provides corresponding spectral component. Amplitudes of these spectral components are achieved by varying the number of cells in the groups. This approach to spectral line synthesis using groups of interferometer cells with equal areas is illustrated in Fig. 2.

Fig. 3 shows the degree of linearity of triangular response versus cutoff frequency  $\omega^*$  of the response spectrum. The cutoff frequency does not depend on period  $B_T$  of the response, but total number  $N^*$  of harmonic components needed does depend on  $B_T$ . In case of response with minimum period  $B_T = 2\Delta B$ , the total the number  $N^*$  is a half the normalized cutoff frequency  $\omega^* \Delta B / \pi$ .

Such an array providing highly linear triangular response can be called LRA – linear response array.

We may compose a complete array using several LRAs connected in series. If voltage responses of the LRAs are characterized by different periods  $B_T$  and the same width  $2\Delta B$  of triangular peak, the complete array will show a

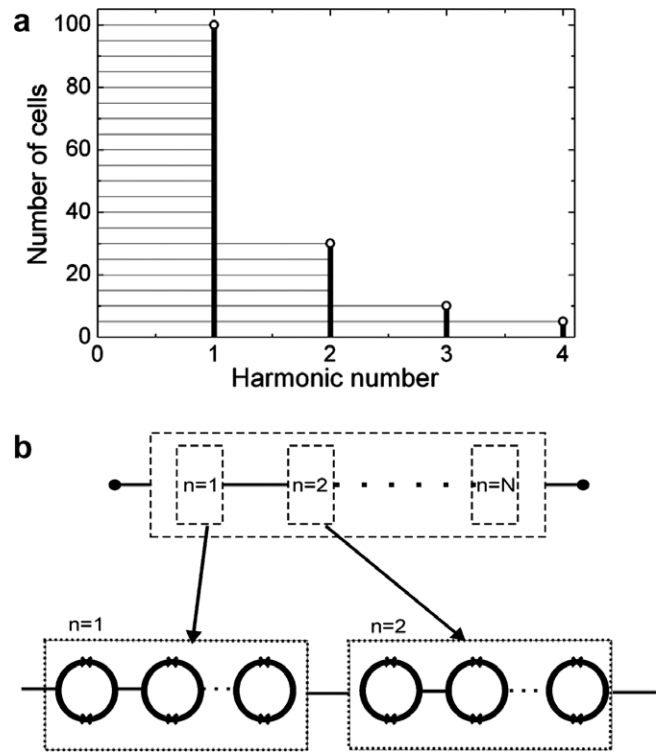

Fig. 2. The spectral line synthesis (a) by groups ( $n = 1, 2, \dots, N$ ) of identical cells (equal areas) with sinusoidal responses (b).

SQIF-like response with a single triangular peak. This array can be called LR SQIF – linear response SQIF. Spectrum of the LR SQIF response consists of a set of basic frequencies  $\omega_0 \Delta B / \pi \leq 1$  and their harmonics in the upper range  $\omega \Delta B / \pi > 1$ , and amplitudes of the spectral components have a *sinc*-like frequency dependence. As for conventional SQIF, its response is characterized by a quasi uniform discrete spectrum in the range specified by the maximum and the minimum cell areas.

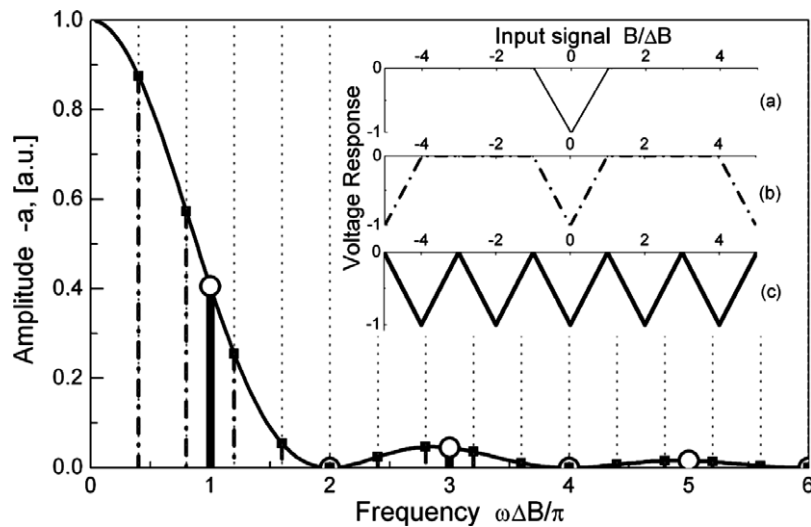

Fig. 1. Spectrum of triangular voltage response on magnetic field. Solid line – continuous spectrum of the voltage response with single triangular peak (a, inset). Dropped lines – spectra of the periodic triangular voltage responses (b) and (c). Inset shows the responses.

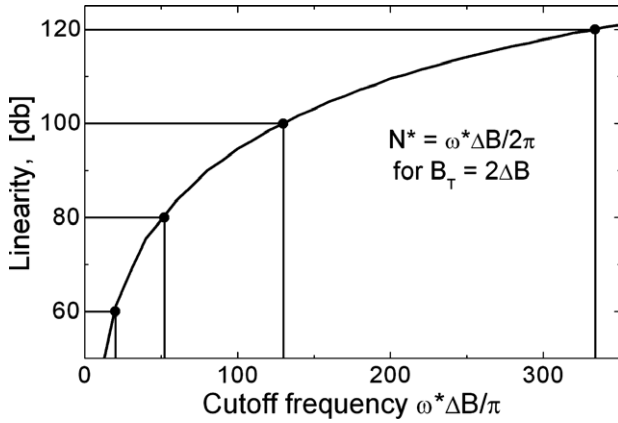

Fig. 3. The triangular response linearity versus cutoff frequency  $\omega^*$  of the response spectrum. In the case  $B_T = 2\Delta B$ , the total number  $N^*$  of harmonic components is a half the normalized cutoff frequency  $\omega^*\Delta B/\pi$ .

One should note that some limitations may result from the large area of an array with the large number of cells. Such an array becomes distributed. To overcome this problem, we suggested a traveling wave amplifier shown schematically in Fig. 4. The amplifier design includes two microwave lines coupled via interferometer cells of a serial array. Input wave signal propagates along the first line and then is absorbed by a matched load. The propagating signal acts magnetically on the interferometer cells inserted in the second microwave line. Voltage responses of the cells induce the output wave running in the second line. Equal velocities of the input and output waves provide sustained in-phase process and hence the effective amplification of the output signal. This approach allows us to avoid size limitation in arrays and therefore achieving very high linearity. It also will lead to the design of wide-band, highly linear amplifiers for gigahertz frequency range.

### 3. High linearity differential parallel-series array structures

In the limit of vanishing inductance  $l$ , the dc interferometer voltage response to a homogeneous magnetic field  $B$  at  $I_b = I_c$  can be reduced as follows:

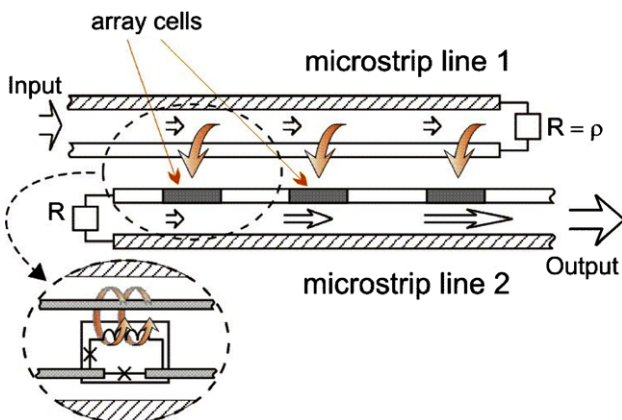

Fig. 4. Traveling wave amplifier consisting of two coupled microwave lines. The inset shows coupling via interferometer cell.

$$V(B) = V_c |\sin(\pi B s_0 / \Phi_0)|, \tag{4}$$

and spectrum of the response shows monotonic fall with harmonic number:

$$a(n\omega_0) = a_0 / (n^2 - 1). \tag{5}$$

If we remove all even harmonics from (5), we come just to spectrum (3) at  $B_T = 2\Delta B$ :

$$a(k\omega_0) = a_0 / ((2k - 1)^2). \tag{6}$$

Some differences in the harmonic amplitudes take place only for initial harmonic numbers. It can be easily seen that applying half a flux quantum to the dc interferometer cell changes the sign of odd harmonic components. This fact leads to an idea of differential scheme of the unbiased and  $\Phi_0/2$ -biased interferometer cells to form the spectrum containing only odd harmonics. Fig. 5 elucidates this idea. One can see the spectrum (open squares) of the voltage response  $V(B)$  of the interferometer which is unbiased magnetically, and the spectrum (filled circles) of the reversed response  $(-V(B))$  of the  $\Phi_0/2$ -biased interferometer. The inset shows the differential response of the unbiased and the  $\Phi_0/2$ -biased interferometer cells. This response (solid line) is sum of the cell responses (dash and dotted lines) with the spectra presented.

The proposed differential circuit of two interferometers can be easily transformed into differential array structure consisting of two serial arrays of dc interferometers with biasing  $I_b = I_c$ , where  $I_c$  is the critical current of interferometers. In one array, each cell should be biased by  $\Phi_0/2$ . This differential array structure is shown schematically in Fig. 6. An additional flux  $\Phi_0/4$  is applied to all interferometer cells to set operating point in the middle of the array response leg.

One can increase the linearity of array voltage response. For this purpose, we should add to the array a few cells

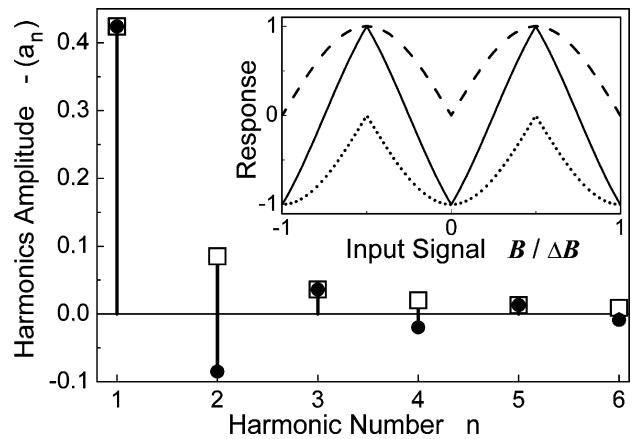

Fig. 5. The voltage response spectra of dc interferometers with vanishing inductances and current biasing  $I_b = I_c$ . The open squares mean spectrum for the magnetically unbiased interferometer, the filled circles – the inversed spectrum for the  $\Phi_0/2$ -biased interferometer. The inset shows triangular voltage response (solid line) on magnetic signal for differential connection of the interferometers, i.e., a sum of the cell responses (dash and dotted lines) with the spectra presented.

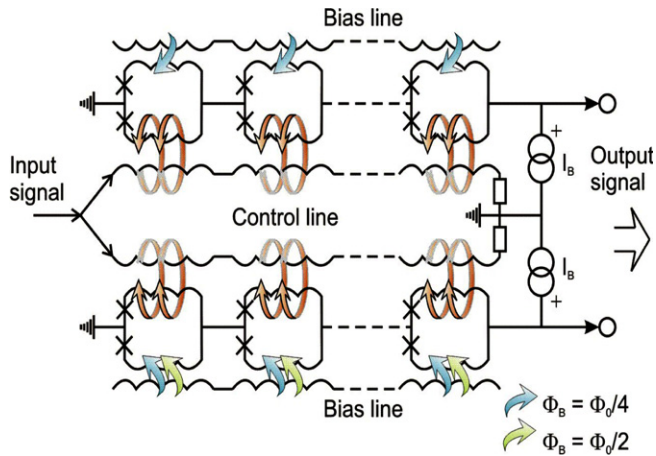

Fig. 6. Differential array structure consisting of two series arrays of dc interferometers with biasing  $I_b = I_c$ , where  $I_c$  – critical current of the interferometers. In one array, each cell is biased by magnetic flux  $\Phi_0/2$ . Additional flux  $\Phi_0/4$  is applied to all cells to set the optimal operating point.

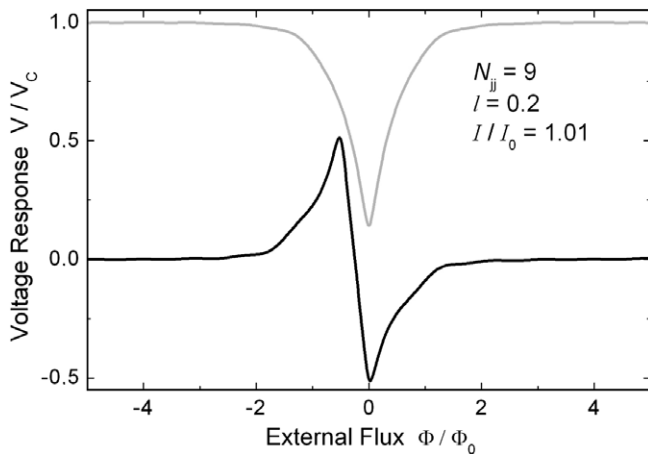

Fig. 7. Voltage response of the differential scheme of two parallel arrays of  $N = 9$  cells to the applied homogeneous magnetic flux (thick line). In one array, each cell is biased by  $\Phi_0/2$ . Voltage response of the unbiased parallel array is shown by thin line. The normalized cell inductance  $l = 0.2$ , bias current  $I/I_0 = 1.01$ , where  $I_0 = 10 \times I_c$ ,  $I_c$  – critical current of one Josephson-junction.

with sinusoidal responses. The cells are dc interferometers biased well above critical current ( $I_b > 2I_c$ ). These additional cells are to correct the initial spectral components in (5) in order to approach the desired spectrum (6).

As for the interferometer inductance influence, we have found that the finite inductance  $l$  gives some additional decrease in amplitudes of only initial spectral components of the spectrum (5), while high harmonics remain the same

and decrease as  $1/n^2$ . Therefore, we need to correct only these initial spectral components. As stated above, this can be done by means of additional cells with sinusoidal responses.

A traveling wave amplifier design proposed above can be also applied to the differential array structure. In this case, we come to a differential traveling wave amplifier. The design includes an input microwave line coupled with two output microwave lines via interferometer cells of two serial arrays forming a differential structure.

If the interferometer cells in both serial arrays are replaced by parallel arrays, we come to a high-performance *parallel-series differential structure*. As an example, Fig. 7 shows voltage response of the differential scheme of two parallel arrays of  $N = 9$  cells to the applied homogeneous magnetic flux. In one array, each cell is biased by  $\Phi_0/2$ .

#### 4. Conclusion

The developed array structures lead to the design of wide-band highly linear amplifiers for gigahertz frequency range. The array-based amplifiers seem being capable of providing essentially higher gain, linearity and dynamical range than the ones shown by SQUID-amplifier [3]. In fact, transfer factor  $dV/dB$  is proportional to number  $N$  of the interferometer cells and dynamic range increases as  $\sqrt{N}$  for both parallel and series arrays. This results from the fact that in case of parallel array the output voltage noise decreases as  $\sqrt{N}$  at fixed voltage response amplitude; in case of series array the output voltage noise increases as  $\sqrt{N}$  and voltage response increases as  $N$ .

In such a way, the use of high enough number  $N$  of interferometer cells provides required dynamic range, and the developed design approaches make the arrays, the LRAs, with extremely high linearity of voltage response.

#### Acknowledgement

This work was supported in part by CRDF Grant RUP1-1493-MO-05 and Russian Grant for Scientific School 1344.2003.2.

#### References

- [1] J. Oppenlaender, Ch. Haeussler, N. Schopohl, Phys. Rev. B 63 (2001) 024511.
- [2] Ch. Haeussler, J. Oppenlaender, N. Schopohl, J. Appl. Phys. 89 (2001) 1875.
- [3] G.V. Prokopenko et al., Appl. Supercond. Conf., Report 4EF10, Jacksonville, FL, USA, October 2004.