

# Supercapacitors in bias systems for low frequency noise measurements

Graziella Scandurra, Carmine Ciofi

Dip. Fisica della Materia e Ingegneria Elettronica  
University of Messina  
Messina, Italy  
cciofi@unime.it

**Abstract**—We explore the possibility of employing supercapacitors in the design of very low noise programmable voltage and current sources to be used for biasing the device under test in low frequency noise measurements. This is accomplished by taking advantage of the large capacitance of supercapacitors for realizing a low pass filter with a very low frequency corner for filtering out the noise produced by a solid state high accuracy DA converter. In order to obtain the desired attenuation of the noise down to a few hundred mHz, a very low frequency corner must be employed, thus resulting in very long transients (in the order of a few hours) upon each voltage change. This problem is specifically addressed in this paper. Indeed, we have designed a programmable voltage reference capable of generating voltages in the range 0-2.5 V with a resolution of about 2.5 mV, an accuracy better than 2 mV and a settling time of about 200 s. The output noise is below  $4 \times 10^{-16}$ ,  $5 \times 10^{-18}$ , and  $1 \times 10^{-18}$  V<sup>2</sup>/Hz at 100 mHz, 1 Hz, and 10 Hz, respectively. The application of such a low voltage reference for the realization of a very low noise programmable current source is also discussed and demonstrated.

**Keywords**—low frequency noise measurements, supercapacitor, programmable bias sources.

## I. INTRODUCTION

The Background Noise (BN) introduced by the voltage or transresistance amplifiers employed for amplifying the signal produced by the Device Under Test (DUT) is often taken as the most important factor that limits the sensitivity of a Low Frequency Noise (LFN) measurement system [1]. Cross correlation techniques have been however developed that may allow, in proper condition, to reliably detect noise levels that are several dB below the equivalent input sources of the amplifiers[2]. Unfortunately, also the noise introduced by the voltage or current sources employed for biasing the DUT may significantly contribute to the overall BN of the system. Contrary to the case of the noise introduced by the amplifiers, correlation techniques cannot be used, in general, to separate the noise introduced by the bias system from the noise produced by the DUT. It is for this reason that the bias of the DUT is generally obtained by resorting to rechargeable high capacity batteries that, when properly employed, can be considered as virtually noise free. Employing batteries has, however, several drawbacks. The voltage supplied by the batteries is not constant over time due to the discharge; only a

limited set of voltages (multiple of the cell voltage) are available and for obtaining continuously changing voltage values one must resort to low resistance, low noise resistive voltage dividers, thus causing a faster discharge of the batteries. The design of a programmable bias system and, as a consequence, the design of a fully automated low frequency noise measurement is therefore virtually impossible. Moreover, batteries need to be frequently recharged and the supplied voltage as well as the generated noise depend on the age of the batteries and on the number of recharges to which they have been subjected. A few approaches have been proposed in the past aiming at the design of programmable, high accuracy voltage references characterized by a sufficiently low level of noise to be suitable for application in the field of LFN measurements [3,4]. In [4], in particular, we investigated the feasibility of what may appear the most obvious approach for the realization of a very low noise programmable voltage reference, that is the one consisting in filtering out the noise produced by a solid state DA converter by means of a low pass filter with a suitably low frequency corner. We will shortly revisit the problems to be solved for such an approach to be effective in order to demonstrate how supercapacitors may allow to simplify the design and open a new range of possibilities.

## II. FILTER DESIGN

In order to design a filter capable of reducing the noise produced by a solid state voltage reference down to an acceptable level for LFN measurements we need to establish what such an acceptable level is. It is not possible, however, to answer this question in general terms, as the contribution of the noise generated by the bias system depends on the level of noise produced by the DUT, on the measurement configuration and DUT impedance as well as on the frequency range of interest. In the following discussion we will assume, however, that the minimum target to be reached is that of obtaining a noise level comparable to or lower than the equivalent input noise of a very low noise voltage preamplifier at frequencies as low as 100 mHz. As a reference amplifier we will assume the one reported in [5] that is among the best ever reported in the literature as far as the equivalent input noise down to 100 mHz is concerned. In particular, the equivalent input noise is about 14 nV/ $\sqrt{\text{Hz}}$ , 1.4 nV/ $\sqrt{\text{Hz}}$  and 1.1 nV/ $\sqrt{\text{Hz}}$  at 100 mHz, 1 Hz and 10 Hz, respectively. Typical values of the noise spectra at the

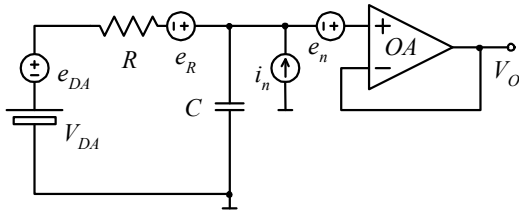

Figure 1. Equivalent schematic for noise estimation.

output of a DA converter in the same frequency range are much larger (40 dB above or more), and therefore an  $RC$  filter providing an attenuation of at least 40 dB at the lowest frequency of interest (100 mHz) is needed. However, we must also take into account the noise introduced by the resistance and by the equivalent input voltage and current noise sources of the buffer amplifier that must be used in order to provide current to a load (Fig. 1). In the hypothesis of a frequency corner much lower than any frequency  $f$  we may be interested in, the total voltage noise at the output of the buffer in Fig. 1 can be calculated as follows:

$$S_{VO} = S_{en} + \frac{S_{in}}{4\pi^2 f^2 C^2} + (S_{DA} + 4KTR) \frac{f_p^2}{f^2} \quad (1)$$

where  $S_{en}$  and  $S_{in}$  are the power spectral densities of the equivalent input voltage and current sources of the buffer ( $e_n$  and  $i_n$ ),  $S_{DA}$  is the power spectrum of the voltage noise at the output of the DA converter ( $e_{DA}$ ),  $K$  is the Boltzmann constant,  $T$  the absolute temperature and  $f_p = 1/2\pi RC$  is the corner frequency of the  $RC$  low pass filter. As it is clear that nothing can be done to reduce the contribution of  $S_{en}$ , we will have to resort to Operational Amplifiers (OA) with very low equivalent input voltage noise for the implementation of the buffer. These are typically BJT input stage OAs such as the OP27 (15 nV/√Hz at  $f=100$  mHz) that are however characterized by a relatively high current noise ( $S_{in}=2.2 \times 10^{-22}$  A<sup>2</sup>/Hz at  $f=100$  mHz). For the contribution of the equivalent input current noise to be negligible with respect to  $S_{en}$ , from (1) with  $f_p=1$  mHz and  $f=100$  mHz, we have that  $C$  must be much larger than about 5 mF, a condition that can only be obtained by resorting to supercapacitors. As far as the noise introduced by the resistance is concerned, from (1) and with  $f_p=1$  mHz and  $f=100$  mHz, we obtain that  $R$  must be less than 100 MΩ. However, since the time constant  $RC$  also sets the frequency corner  $f_p$ ,  $R$  is set once  $C$  is set. For instance, with  $C=1$  F we have  $R=160$  Ω. Moreover, for the choice of  $R$ , we must take into account the effect of the leakage current through the capacitor that may be quite significant in the case of supercapacitors. The leakage current may introduce a significant error in the output voltage because of the voltage drop across  $R$ . In our experiments we selected a 22 F supercapacitor (by PowerStor, aerogel, series B, 2.5 V). The plot of the current charging the capacitor and of the output voltage in the  $RC$  filter in response to a 2 V step is shown in Fig. 2. A resistance of 22 Ω was used in the circuit in order to maintain the charging current below 100 mA (the maximum limit for the HP4155 B semiconductor parameter analyzer that was employed for performing the measurements). The dashed

line represents the plot of the current that would have been obtained in the case of an ideal 22 F capacitor.

From the plot in Fig. 2 we observe that the current absorbed by the supercapacitor is much larger than what would be expected when approaching the steady state condition. Indeed, as it can be demonstrated by direct experiments that are not reported here, current continues to flow through the capacitor when biased at constant voltage for several hours before stabilizing to a value of less than 20 μA. This behavior is due to the kinetic of the process of charge storage in supercapacitors and resemble, to some extent, what could be observed in charging accumulators. Assuming that the steady state is reached, for the leakage current to produce a voltage drop less than 1 mV in the resistance, a value of  $R$  less than 50 Ω must be used. With  $C=22$ F a resistance of 20 Ω is sufficient to obtain  $f_p=360$  μHz, and therefore we may expect, in this situation, a final error at steady state of less than 400 μV.

For the approach of filtering out the noise produced by a solid state DA converter to be of any practical use, however, the problem of the very long time required for reaching the steady state upon a voltage change must be solved. With reference to the graph in Fig. 2, after 3 hours since the voltage step of 2 volt is applied to the filter, the capacitor is still absorbing about 100 μA, with a voltage drop across the resistance of a few mV. In order to speed up the charging process we could resort to the expedient of connecting a much smaller resistance in parallel to  $R$  during any voltage change. We could monitor the output voltage and then disconnect such a resistance when close to the desired value. This approach, however, would result ineffective because, as we have observed before, even when the voltage across the capacitor is close to the one at the steady state, the charging process is far from being complete. In order to monitor and speed up the charging process, therefore, we employed the circuit in Fig. 3. The idea is essentially that of monitoring the charging current and to provide for an additional fast charging/discharging path as long as the charging current stays above a threshold that is

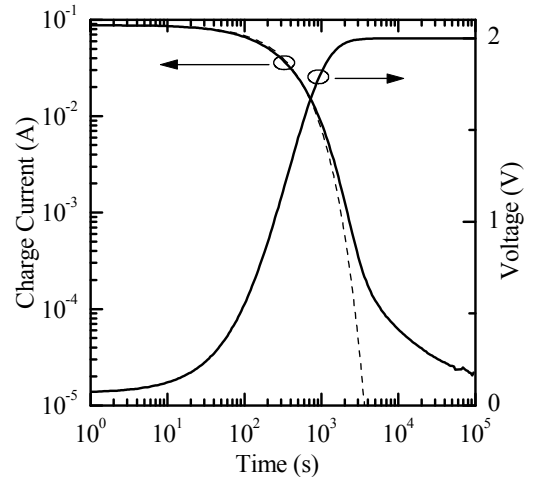

Figure 2. Plot of the current charging the capacitor and of the output voltage in the  $RC$  filter in response to a 2 V step.

determined by the circuit parameters. The instrumentation amplifier  $IA$  (INA131, gain=100) monitors the current flowing through the resistor  $R$ . The charging path ( $D_1, D_2$  and the Darlington  $Q_1$ ) is only activated when the difference between the output voltage of  $IA$  and the voltage across the capacitor is larger than about 2.5 V, corresponding to a voltage across  $R$  of more than 25 mV (corresponding, in turn, to a current of about 125  $\mu$ A with  $R=20 \Omega$ ). In the same way, the discharging path ( $D_3, D_4$  and the Darlington  $Q_2$ ) is only activated when the difference between the output voltage of  $IA$  and the voltage across the capacitor is less than about -2.5 V, corresponding to a voltage across  $R$  of less than -25 mV ( $V_{CC}=-V_{EE}=12V$ ). The resistance  $R_C$  (50  $\Omega$ ) limits the value of the charging current to about 100 mA. With this circuit, the time required to reach the condition of  $\pm 2.5$  mV across the resistance  $R$  is reduced to a few hundred seconds. After this time, the transistors  $Q_1$  and  $Q_2$  are turned off and we obtain the full action of the filter on the noise produced by the  $DA$ . Changing the gain of the  $IA$  or changing the number of diodes in the charging and discharging path may allow to reach a condition even closer to that of the steady state before the transistors are disconnected. However, in LFN measurements which we are interested in (with frequencies as low as 100 mHz) a settling time of a few minutes upon any voltage change can be regarded as acceptable in comparison with the measurement time that is required for a correct estimation of the spectra at very low frequencies.

### III. EXPERIMENTS

The circuit described in Fig. 3 was built and tested in order to verify the effectiveness of the approach we propose. The entire circuit is supplied by two 12 V Lead acid batteries. The DA converter was an AD667 using its own internal voltage reference. In the circuit configuration that has been used, the resolution of the DA is 2.5 mV (1 LSB for a 12 bit DA converter with a dynamic range of 10 V). The output accuracy for the AD667 is 1/4 LSB, corresponding to about 600  $\mu$ V. The

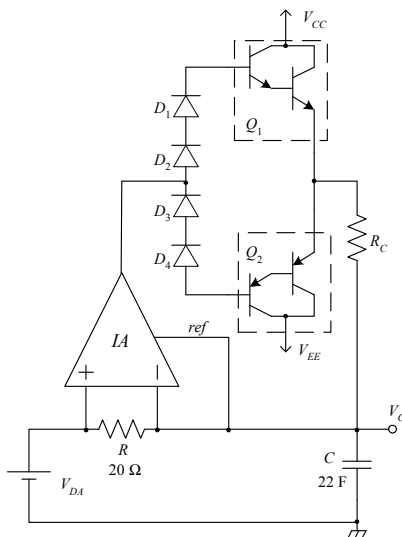

Figure 3. Circuit employed in order to monitor and speed up the charging process.

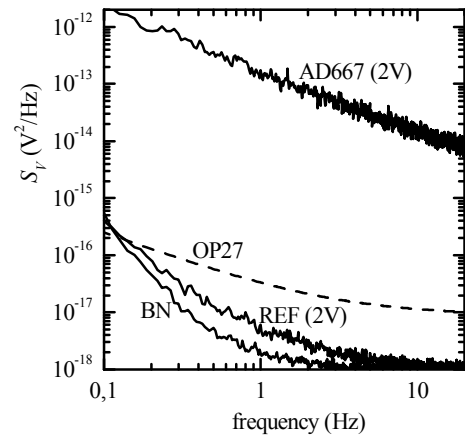

Figure 4. power spectrum of the voltage fluctuations at the output of the DA converter (AD667), output voltage noise of the voltage reference (REF), input voltage noise of the OP27 employed as buffer, BN of the low noise amplifier

experiments were performed with the DA supplying 2 V upon system turn on. The low noise preamplifier described in [5] was used in all noise measurements. The power spectrum of the voltage fluctuations at the output of the DA converter is reported in Fig. 4. In the same plot, we report the equivalent input voltage noise of the preamplifier employed for the measurements. As it is apparent, the noise at the output of the circuit in Fig. 3 is quite close to the BN of the low noise amplifier (the BN was not subtracted), thus making it quite difficult to determine the sole contribution of the voltage reference. By observing the plot on Fig.4, however, it is apparent that excess noise is present in the frequency range between 100 mHz and about 3 Hz that cannot be justified by the analysis we have done. At this stage it is unclear whether such an excess noise is caused by the effect of the circuit employed for speeding up the charging or depends on the detailed characteristics of the supercapacitor that only as a first order approximation can be considered an ideal capacitor [6]. It must be observed, however, that if a low noise, low offset operational amplifier such as the OP27 is employed as a buffer for delivering current to a load, the resulting output noise would be set by the equivalent input voltage noise of the OP27 (Fig. 4).

The new programmable voltage reference can be used for building a low noise programmable current source as in Fig. 5[4]. The circuit is supplied by an independent 12 V battery. The output current  $I_O$  is given by

$$I_O = \frac{V_{REF} - V_{GS}}{R_S} \quad (2)$$

Since the JFET gate to source voltage  $V_{GS}$  contributes to set the output current, the accuracy and temperature stability that can be obtained depend on the characteristics of the JFET. In the circuit in Fig. 5 an IF3601 is used which is characterized by a typical pinch off voltage of -1 V and by  $V_{GS}$  in the order of a few hundred mV when delivering currents in the order of a few mA. The output current could be however precisely estimated from the voltage drop across the resistance  $R_S$  and the output of

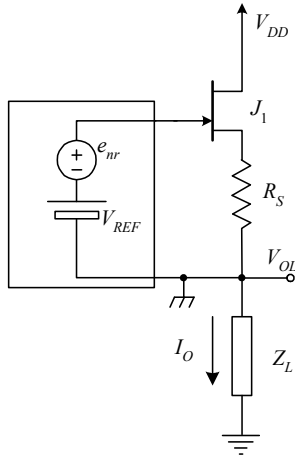

Figure 5. low noise programmable current source implemented employing the new programmable voltage reference

the programmable source adjusted until the desired value is obtained. The equivalent input voltage noise of the JFET is about 3dB below that of the amplifier employed for low noise measurements that indeed is based on a IF3602 JFET input differential stage[5]. In the experiment we performed  $R_S=200\ \Omega$  and  $Z_L$  is a  $500\ \Omega$  excess noise free resistor. With the output of the low noise reference set to 2 V we obtain a current flowing through the load of about 14 mA. The current noise delivered to the load can be approximated as follows [1]:

$$S_{I_O} = \frac{S_{enFET} + S_{enREF} + 4kTR_S}{R_S^2} \quad (3)$$

where  $S_{enFET}$  and  $S_{enREF}$  are the power spectral densities of the equivalent input voltage noise of the JFET and of the voltage noise at the output of the reference, respectively, and the hypothesis  $g_m R_S \gg 1$  has been made where  $g_m$  is the transconductance of the JFET (in the order of 50 mA/V).

In order to estimate  $S_{I_O}$  we measured the voltage noise across the load. Note that the thermal noise of the load resistance also contributes to the output voltage noise that can be written as follows, with  $Z_L=R_L$ :

$$S_{V_O} = S_{I_O} R_L^2 + 4KTR_L \quad (4)$$

The result of the measurement of  $S_{V_O}$  is shown in Fig.6. As it is apparent from the figure, down to about 2 Hz the measured noise coincide with that due to the effect of the thermal noise of the resistances  $R_S$  and  $R_L$  alone ( $S_{I_O} < 1 \times 10^{-22}\ \text{A}^2/\text{Hz}$ ) while at lower frequencies the output noise is mainly due to the effect of the equivalent input noise of the JFET J1 in Fig. 5. At frequencies as low as 100 mHz the current noise is below  $4 \times 10^{-21}\ \text{A}^2/\text{Hz}$ , which has to be regarded as an excellent result.

#### IV. CONCLUSIONS

We have investigated the feasibility of employing supercapacitors for the design of programmable, very low noise voltage and current sources by resorting to

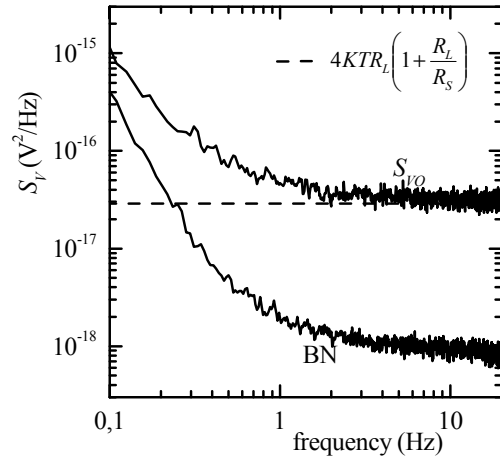

Figure 6. result of the measurement of the voltage noise across the load ( $S_{V_O}$ ) in the circuit in Fig. 5.

supercapacitors. The problem of the large transients resulting from the very low cut-off frequency that has to be set in order to reduce the noise generated by a solid state DA converter down to 100 mHz has been addressed and solved. By means of a simple circuit that senses the charging current, additional current is made to flow through the capacitor only during transients. In this way transients that would have lasted several hours have been reduced to a few minutes. The programmable voltage source has also been employed for testing the possibility of designing a simple programmable current source. In the testing conditions that have been used, the contribution of the programmable reference to the output current noise is negligible with respect to the other sources of noise. Further work needs to be done in the characterization of supercapacitors in order to understand the excess noise that is measured with respect to that calculated by modeling this device as an ideal capacitor.

#### REFERENCES

- [1] C. Ciofi, G. Giusi, G. Scandurra, B. Neri, "Dedicated instrumentation for high sensitivity, low frequency noise measurement systems," *Fluct. Noise Letters*, vol. 4, pp.384-402, 2004.
- [2] M. Sampietro, G. Accomando, L.G. Fasoli, G. Ferrari, E.C. Gatti, "High sensitivity noise measurement with a correlation spectrum analyzer," *IEEE Trans. Instr. Meas.*, vol. 49, p.820, 2000.
- [3] L. Baracchino, G. Basso, C. Ciofi, B. Neri, "Ultralow-Noise, Programmable, Voltage Source", *IEEE Trans. Instr. Meas.*, vol. 46, p. 1256 (1997).
- [4] C. Pace, C. Ciofi, F. Crupi, "Very low noise, high accuracy programmable voltage reference", *IEEE Trans. Instr. Meas.* vol 52, p. 1251, (2003).
- [5] G. Canntà, G. Scandurra, C. Ciofi, "An ultralow noise preamplifier for low frequency noise measurements", *Rev. Sci. Instr.*, vol. 80, n. 114702 (2009).
- [6] S. Buller, E. Karden, D. Kok, R. W. De Doncker, "Modeling the Dynamic Behavior of Supercapacitors Using Impedance Spectroscopy", *IEEE Trans. Indus. Appl.*, vol 38, p.1622 (2002).
- [7] C. Ciofi, R. Giannetti, V. Dattilo, B. Neri, "Ultra Low-Noise Current Sources" *IEEE Trans. Instr. Meas.* vol. 47, p. 78, (1998).